

# ILLUSTRATED PARTS BREAKDOWN

**PARTNER**

**11 HP, 36" MOWER DECK**

**LAWN TRACTOR**

**MODEL NUMBER 11-92 (P1136C)**

**964 77 07-00**

[www.emc-motoculture.com](http://www.emc-motoculture.com)



# REPAIR PARTS

TRACTOR- -MODEL NO. 11-92 (P1136C), PRODUCT NO. 964 77 07-00  
ELECTRICAL

KEY NO.	PART NO.	DESCRIPTION
1	532 16 34-65	Battery
2	874 76 04-12	Bolt Hex Hd 1/4-20unc X 3/4
8	532 17 66-89	Box Battery Fender
16	532 17 61-38	Switch Interlock
24	532 12 47-80	Cable Battery 6 Ga 11" Red
25	532 14 61-47	Cable Battery 6 Ga Red w/16 wir
26	532 17 51-58	Fuse
27	873 51 04-00	Nut Keps Hex 1/4-20 Unc
28	532 12 47-73	Cable Ground 6 Ga 12" black
29	532 12 13-05	Switch Plunger Nc Gray
30	532 17 55-67	Switch Ign
33	532 14 04-01	Key
40	532 17 97-30	Harness Ing
41	871 11 04-08	Bolt Blk Fin Hex 1/4 - 20 x 1/2
42	532 13 15-63	Cover Terminal Red
43	532 17 88-61	Solenoid
48	532 14 08-44	Adapter Ammeter Rectangular
52	532 14 19-40	Protection Wire Loop
89	532 18 04-49	Cover Terminal Battery

**NOTE:** All component dimensions given in U.S. inches.  
1 inch = 25.4 mm.

www.emc-motors.com

# REPAIR PARTS

TRACTOR- -MODEL NO. 11-92 (P1136C), PRODUCT NO. 964 77 07-00  
CHASSIS AND ENCLOSURES

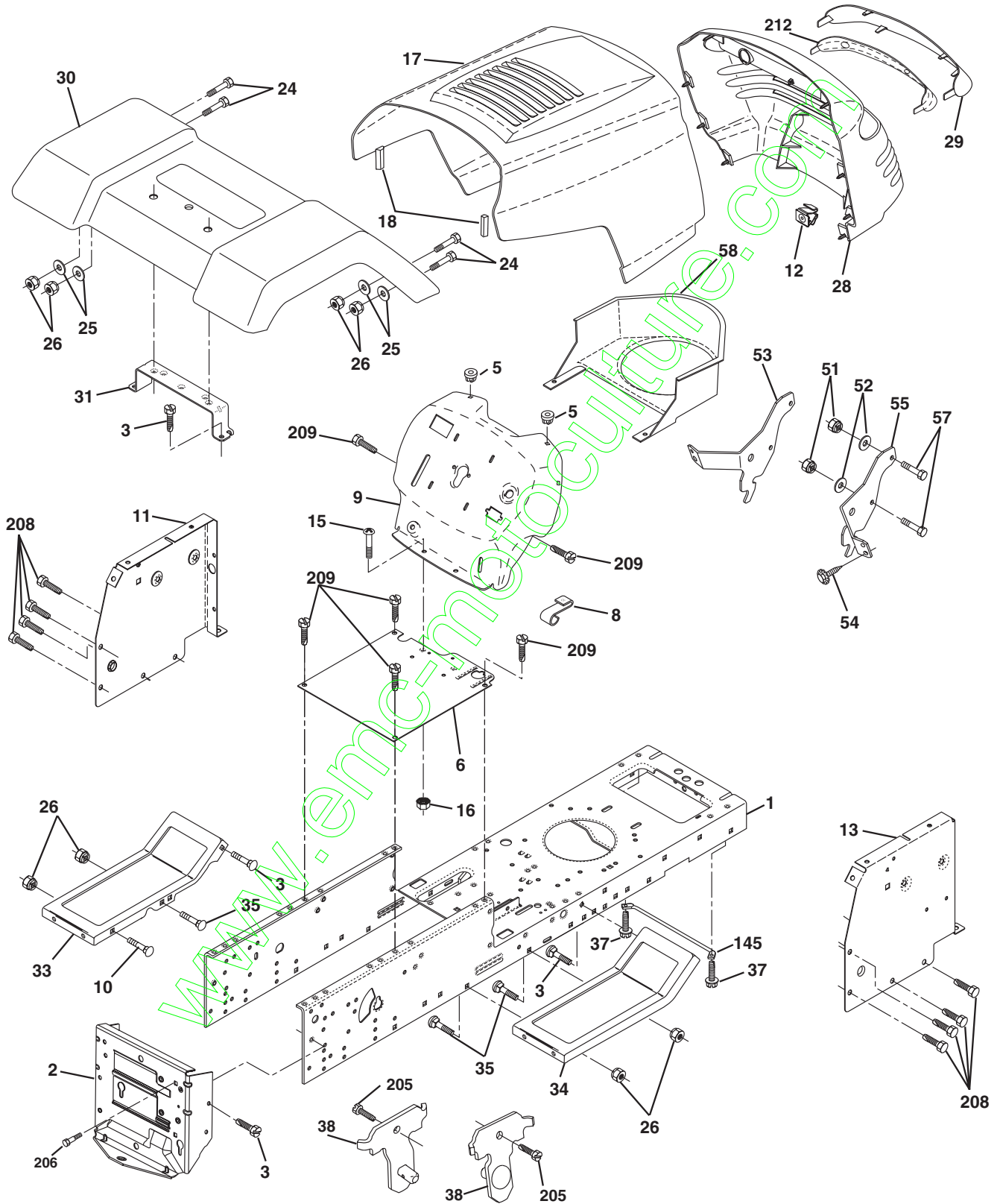

# REPAIR PARTS

TRACTOR- -MODEL NO. 11-92 (P1136C), PRODUCT NO. 964 77 07-00  
CHASSIS AND ENCLOSURES

KEY NO.	PART NO.	DESCRIPTION
1	532 17 46-20	Chassis
2	532 17 65-54	Drawbar
3	817 06 06-12	Screw 3/8-16 x 3/4
5	532 15 52-72	Bumper Hood/Dash
6	532 18 12-71	Saddle
8	532 15 51-38	Clip, Retainer Slide-On
9	532 17 22-43	Dash
10	872 14 06-08	Bolt, Carriage 3/8-16 x 1
11	<b>532 17 49-96</b>	Dashboard, panel LH
12	532 14 56-60	Clip Tinnerman Grille P/L
13	<b>532 18 17-19</b>	Dashboard, panel RH
15	874 18 05-12	Machine screw 5/16-18 unc x 3/4
16	873 51 05-00	Nut, Keps 5/16-18 Unc
17	532 16 03-82	Hood Pnt
18	532 12 69-38	Bumper Hood
24	874 78 06-16	Bolt, Hex Head, Fin. 3/8-16 x 1 Grade 5
25	819 13 13-12	Washer 13/32 x 13/16 x 12 Gauge
26	873 80 06-00	Nut Lock Hex w/Ins. 3/8-16 Unc
28	532 17 97-79	Grille/Lens Asm
29	532 18 12-73	Lens
30	532 18 12-72	Fender
31	532 13 66-19	Fender Bracket
33	532 18 10-57	Footrest, LH
34	532 18 10-58	Footrest, RH
35	872 11 06-06	Bolt 3/8-16 X 3/4
37	817 49 05-08	Screw Thdrol 5/16-18 x 1/2
38	532 17 57-10	Bracket Asm. Pivot Mower Rear
51	873 80 04-00	Nut Lock, w/Insert 14/20 UNC
52	819 09 14-16	Washer 9/32 x 7/8 x 16 Ga.
53	532 14 46-97	Bracket Grille LH
54	532 16 14-64	Screw Hex WsHd 8-18 x 7/8
55	532 14 46-96	Bracket Grille RH
57	874 78 04-12	Bolt FinHex 1/4-20 UNC x .75
58	532 15 01-27	Duct Air Engine P/L LT
145	532 15 65-24	Rod Pivot Chassis/Hood
205	817 49 06-08	Screw Thdrol 3/8-16 x 1/2
206	532 17 01-65	Bolt Shoulder 5/16-18 TT
208	817 67 06-08	Screw Thdrol 3/8-16 x 1/2
209	817 00 06-12	Screw Hexwsh Thdr 3/8-16 x 3/4
212	532 15 64-94	Insert Lens Reflect
--	532 00 54-79	Button Plug

**NOTE:** All component dimensions given in U.S. inches.  
1 inch = 25.4 mm.

# REPAIR PARTS

TRACTOR- -MODEL NO. 11-92 (P1136C), PRODUCT NO. 964 77 07-00  
DRIVE

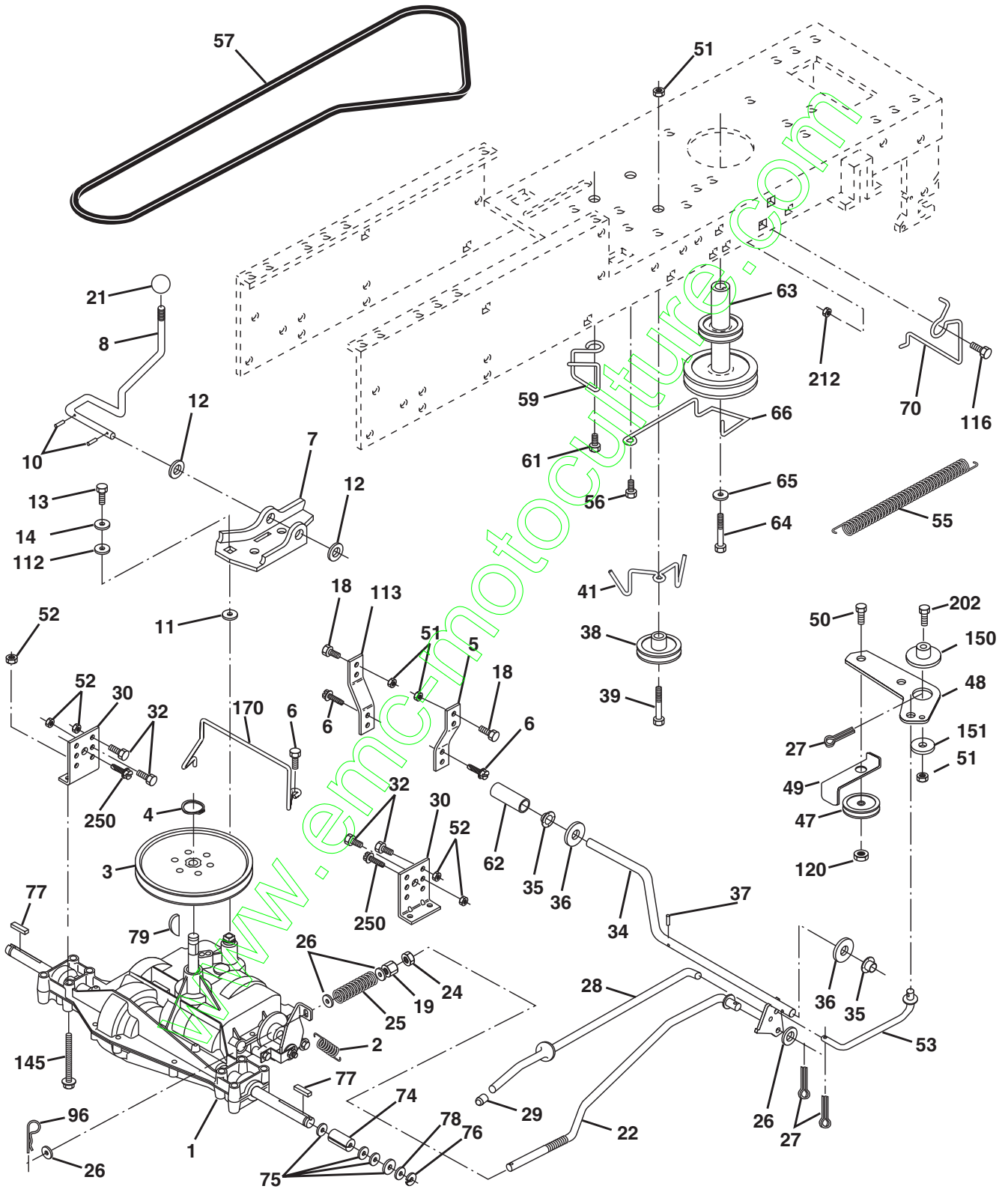

# REPAIR PARTS

TRACTOR- -MODEL NO. 11-92 (P1136C), PRODUCT NO. 964 77 07-00

## DRIVE

KEY NO.	PART NO.	DESCRIPTION	KEY NO.	PART NO.	DESCRIPTION
1	-----	Transaxle (See Breakdown) Peerless, Model 204-506B Order parts from transaxle manufacturer	49	532 12 32-05	Retainer, Belt
2	532 14 66-82	Spring, Brake Return	50	874 76 06-24	Bolt, Hex 3/8-16 x 1-1/2
3	532 12 36-66	Pulley, Transaxle	51	873 68 06-00	Nut, Crownlock 3/8-16
4	812 00 00-28	Ring, Retainer	52	873 68 05-00	Nut, Crownlock 5/16-18
5	532 12 15-20	Strap, Torque	53	532 10 57-10	Link, Clutch
6	817 06 05-12	Screw, 5/16-18 x 3/4 SMGML	55	532 10 57-09	Spring, Return, Clutch
7	532 16 22-40	Bracket, T/A, Saddle Shift	56	817 06 06-20	Screw 3/8-16 x 1-1/4
8	532 13 16-79	Rod, Shifter	57	532 13 08-01	V-Belt, Drive
10	876 02 04-16	Pin, Cotter 1/8 x 1	59	532 16 96-91	Keeper Belt Center Span
11	532 10 57-01	Washer, Shift Plate	61	817 12 06-14	Screw 3/8-16 x .875
12	819 15 12-16	Washer 15/32 x 3/4 x 16	62	532 12 48-72	Cover, Foot Pedal
13	874 55 04-12	Bolt 1/4-28 UNF Gr. 8 w/Patch	63	<del>532 18 02-19</del>	Pulley, Engine
14	810 04 04-00	Washer Lock	64	871 17 07-64	Bolt, Hex 7/16-20 x 4 Gr. 5
18	874 78 06-16	Bolt, Fin Hex 3/8-16 Unc x 1 Gr. 5	65	810 04 07-00	Washer, Lock Hvy Hlcl Spr 7/16
19	873 80 06-00	Locknut 3/8-16	66	532 15 47-78	Keeper, Belt Engine F-Proof
21	532 10 69-33	Knob	70	<del>532 18 02-18</del>	Guide Belt Mower Drive RH
22	532 13 08-04	Rod, Brake	74	532 13 70-57	Spacer, Split
24	873 35 06-00	Nut, Hex Jam 3/8-16	75	532 12 17-49	Washer 25/32 x 1-1/4 x 16 Ga.
25	532 10 68-88	Spring, Rod, Brake	76	812 00 00-01	E-Ring
26	819 13 13-16	Washer 13/32 x 13/16 x 16 Gauge	77	532 12 35-83	Key Square
27	876 02 04-12	Pin, Cotter 1/8 x 3/4	78	532 12 17-48	Washer 25/32 x 1-5/8 x 16 Ga.
28	532 17 57-65	Rod, Brake, Park	79	532 12 50-96	Key Woodruff #9 3/16 x 3/4
29	532 07 16-73	Cap, Plunger	96	532 12 47-80	Retainer Spring 1" Ziinc/Cad
30	532 17 49-73	Bracket, Transaxle, L.H.	112	819 09 12-10	Washer 9/32 x 3/4 x 10 Ga.
32	874 76 05-12	Bolt Hex Hd 5/16-18 UNC x 3/4	113	532 12 72-85	Strap Torque L.H. Lt
34	532 17 55-78	Shaft, Foot Pedal	116	872 14 06-08	Bolt RDHD SQNK 3/8-16unc x 1
35	532 12 01-83	Bearing Nylon	120	873 90 06-00	Nut Lock Flg. 3/8-16 Unc
36	819 21 16-16	Washer 21/32 x 1 x 16 Gauge	145	874 49 05-40	Bolt, Hex Flghd 5/16-18 Gr. 5
37	532 12 49-63	Pin, Roll 3/16 x 1	150	532 17 54-56	Spacer Retainer
38	532 17 91-14	Pulley Idler	151	819 13 32-10	Washer 13/32 x 2 x 10 Ga.
39	874 76 06-48	Bolt Fin Hex 3/8-16unc x 3	170	532 17 83-94	Keeper, Belt, Transaxle
41	532 17 55-56	Keeper, Belt	202	872 11 06-14	Bolt Carr Sh 3/8-16 x 1-3/4 Gr. 5
47	532 12 77-83	Pulley, Idler	212	532 14 52-12	Nut Hex Flange Lock
48	532 15 44-07	Bellcrank Asm Clutch	250	817 06 06-12	Screw, 3/8-16 x 3/4 SMGML

**NOTE:** All component dimensions given in U.S. inches  
1 inch = 25.4 mm

www.emc-motocycle.com

# REPAIR PARTS

TRACTOR- -MODEL NO. 11-92 (P1136C), PRODUCT NO. 964 77 07-00  
STEERING ASSEMBLY

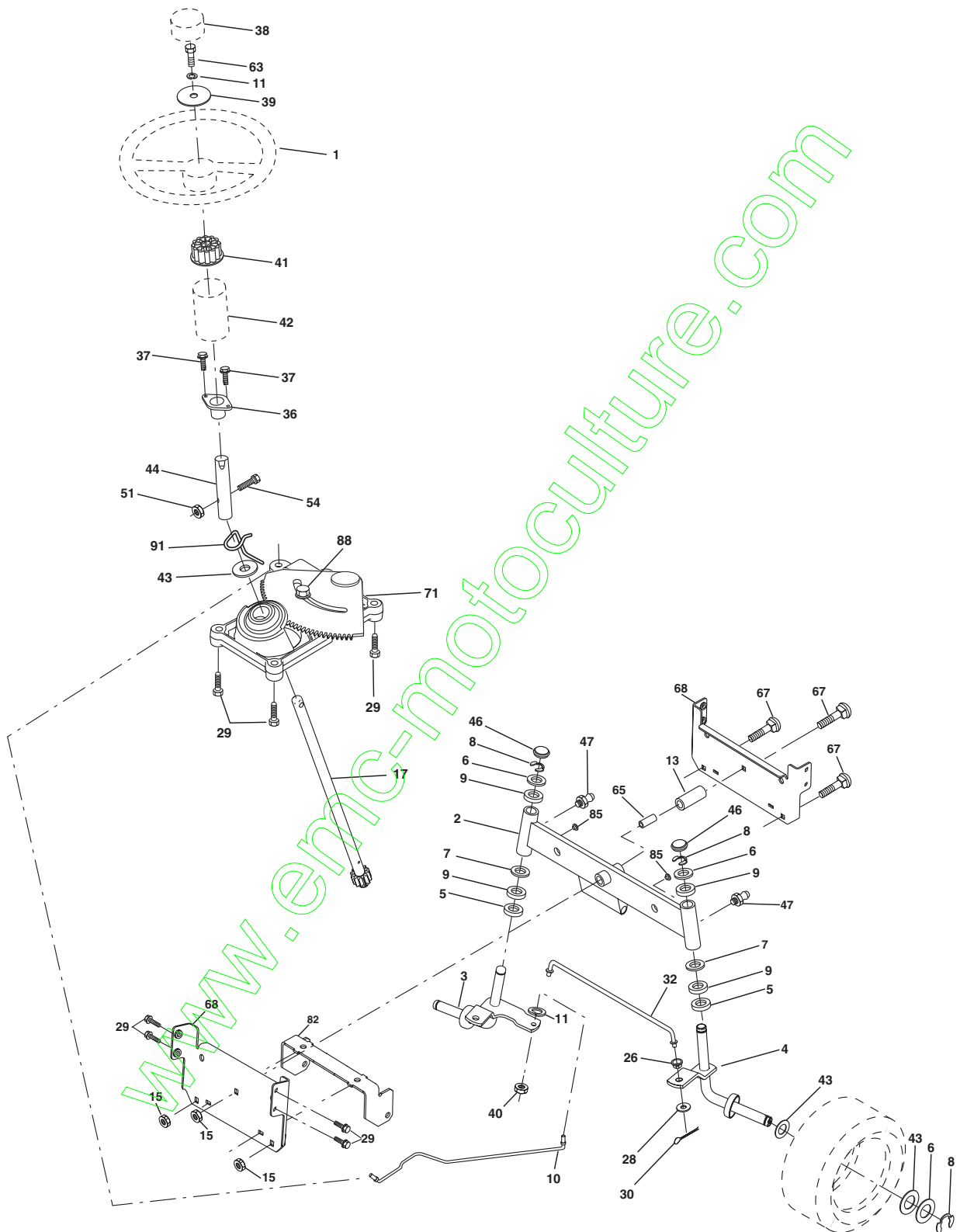



# REPAIR PARTS

TRACTOR- -MODEL NO. 11-92 (P1136C), PRODUCT NO. 964 77 07-00  
STEERING ASSEMBLY

KEY NO.	PART NO.	DESCRIPTION
1	532 13 97-68	Wheel Steering Opp. Sears Blk
2	532 17 51-31	Axle Asm
3	532 16 98-40	Spindle Asm LH
4	532 16 98-39	Spindle Asm RH
5	532 12 49-31	Bearing Race Thrust Harden
6	532 12 17-48	Washer 25/32 x 1-5/8 x 16 Ga
7	819 27 20-16	Washer 27/32 x 1-1/4 x 16 Ga
8	812 00 00-29	Ring Klip #t5304-75
9	532 12 49-37	Bearing Col Strg Blk
10	532 17 51-21	Link Drag
11	810 04 06-00	Washer Lock Hvy Hlcl Spr 3/8
13	532 13 65-18	Spacer Brace Axle
15	532 14 52-12	Nut Hexflange Lock
17	532 17 78-76	Shaft Asm Strg
26	532 12 68-47	Bushing Link Drag Blk LR
28	819 13 14-16	Washer 13/32 x 7/8 x 16 Ga
29	817 06 06-12	Screw 3/8-16 x 75
30	876 02 04-12	Pin Cotter 1/8 x 3/4 Cad
32	532 13 04-65	Rod Tie Wire Form 19 75 Mech
36	532 15 50-99	Bushing Strg Nat .623/.618ld
37	532 15 29-27	Screw TT #10-32 x 5 x 3/8 Flange
38	532 14 01-75	Cap Wheel Steer P/L
39	819 13 38-12	Washer 13/32 x 2-3/8 x 12 Ga
40	532 12 47-01	Nut Lock Center 3/8-24unf
41	532 10 07-11	Adaptor Wheel Strg
42	532 16 96-33	Boot Shaft Steering
43	532 12 17-49	Washer 25/32 X 1 1/4 X 16 Ga
44	532 15 37-20	Extension Steering
46	532 12 12-32	Cap Spindle Fr Top Blk
47	532 12 48-36	Fitting Grease
51	873 80 05-00	Nut Lock Hx w/Ins 5/16-18 Unc
54	874 78 05-20	Bolt Fin Hex 5/16-18 Unc x 1-1/4
63	874 78 06-16	Bolt Fin Hex 3/8-16 UNC Gr. 5
65	532 16 03-67	Spacer Brace Axle
67	872 14 06-18	Bolt RDHD SQ 3/8-16 UNC x 2-1/4
68	532 16 98-27	Brace Axle
71	532 17 51-46	Steering Asm
82	532 16 98-35	Bracket Susp. Chassis Front
85	532 13 38-35	Fastener Christmas Tree
88	532 17 51-18	Bolt Shoulder 7/16-20
91	532 17 55-53	Cup Steering

**NOTE:** All component dimensions given in U.S. inches.  
1 inch = 25.4 mm.

# REPAIR PARTS

TRACTOR- -MODEL NO. 11-92 (P1136C), PRODUCT NO. 964 77 07-00  
SEAT ASSEMBLY

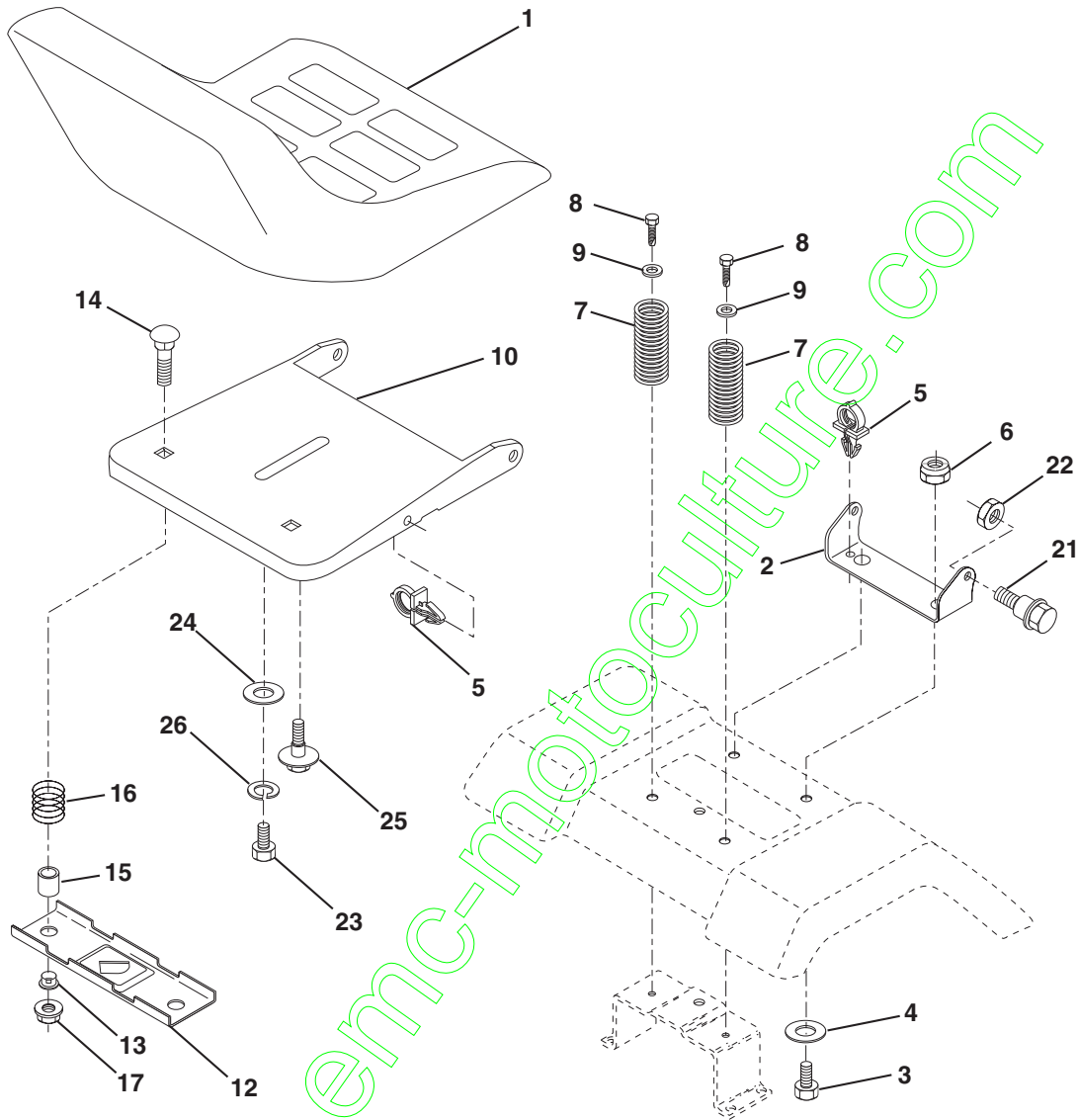

KEY NO.	PART NO.	DESCRIPTION
1	532 17 53-89	Seat
2	532 14 05-51	Bracket Pivot Seat 8 720
3	871 11 06-16	Bolt Fin Hex 3/8-16unc x 1
4	819 13 16-10	Washer 13/32 x 1 x 10 Ga
5	532 14 50-06	Clip Push-In
6	873 80 06-00	Nut Lock Hex w/Wsh 3/8-16 Unc
7	532 12 41-81	Spring Seat Cprsn 2 250 Blk Zi
8	817 00 06-16	Screw 3/8-16 x 1.5
9	819 13 16-14	Washer 13/32 x 1 x 14 Ga.
10	532 17 48-94	Pan Seat
12	532 12 12-46	Bracket Mounting Switch
13	532 12 12-48	Bushing Snap Blk Nyl 50 Id

KEY NO.	PART NO.	DESCRIPTION
14	872 05 04-12	Bolt Rdhd Sht Nk 1/4-20 x 1-1/2
15	532 13 43-00	Spacer Split 28 x 96 Yel Zinc
16	532 12 12-50	Spring Cprsn 1 27 Blk Pnt
17	532 12 39-76	Nut Lock 1/4 Lge Flg Gr 5 Zinc
21	532 17 18-52	Bolt Shoulder 5/16-18 Unc -2A
22	873 80 05-00	Nut Lock Hex W/Insert 5/16-18 UNC
23	871 11 08-14	Bolt Hex
24	819 17 19-12	Washer 17/32 x 1-3/16 x 12 Ga.
25	532 12 70-18	Bolt Shoulder 5/16-18 x 62
26	810 04 08-00	Washer Lock Hvy HLCLSPR 1/2

**NOTE:** All component dimensions given in U.S. inches.  
1 inch = 25.4 mm

# REPAIR PARTS

TRACTOR- -MODEL NO. 11-92 (P1136C), PRODUCT NO. 964 77 07-00

## DECALS

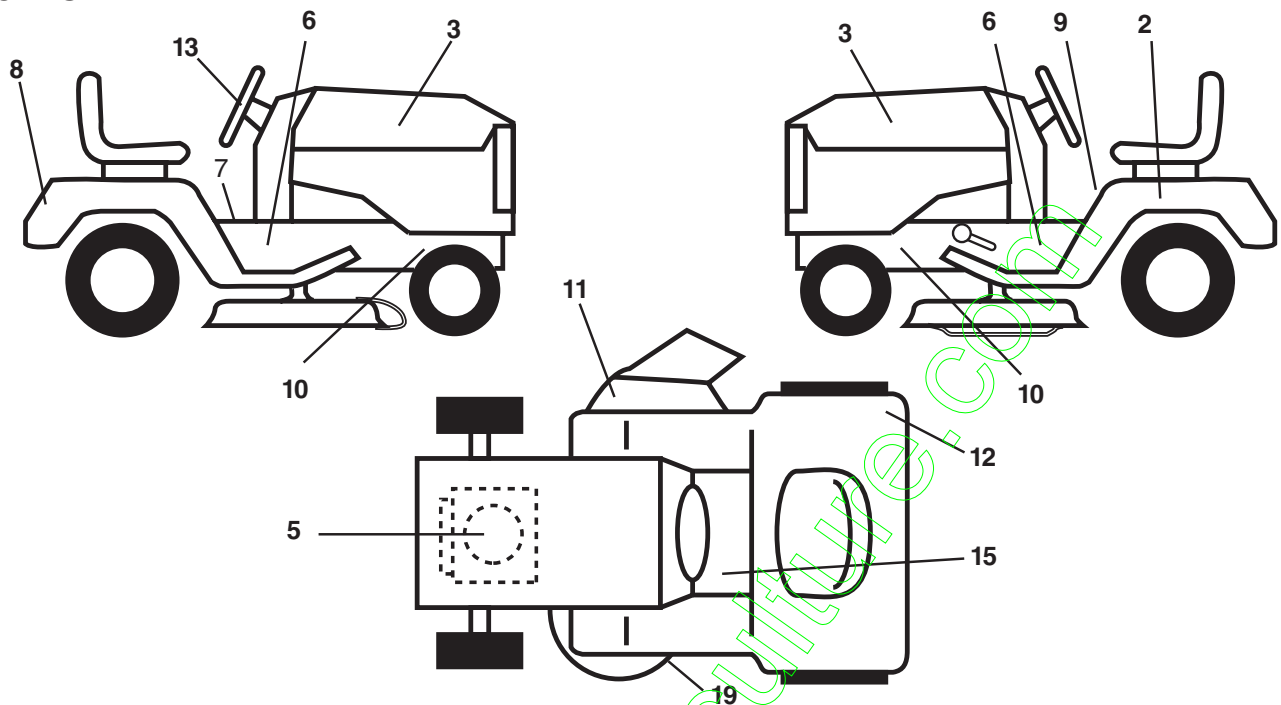

KEY NO.	PART NO.	DESCRIPTION
2	532 14 50-05	Decal Bat Dan/Poi P/L Symbols
3	532 14 09-87	Decal Hood
5	532 17 08-43	Decal Engine
6	532 13 75-88	Decal Chas. Turbo Collection
7	532 14 08-37	Decal Saddle Brake Parking
8	532 14 09-87	Decal Fender Logo
9	532 14 54-98	Decal Read Owners Manual Syms
10	532 15 97-36	Decal Chassis Hot Muffler
11	532 14 54-94	Decal Mower Cut finger Symbol

KEY NO.	PART NO.	DESCRIPTION
12	532 18 04-32	Decal 100 DbA
13	532 14 69-98	Decal Strg Wheel Cap
15	532 15 97-37	Decal Brake/Clutch
19	532 13 68-32	Decal V-Belt Sch
--	532 16 25-98	Decal Drawbar Load Limit
--	532 13 83-11	Decal Lift Handle (Lift Handle)
--	532 18 17-39	Manual Operator's Euro
--	532 18 17-40	Manual Operator's Scan

## WHEELS & TIRES

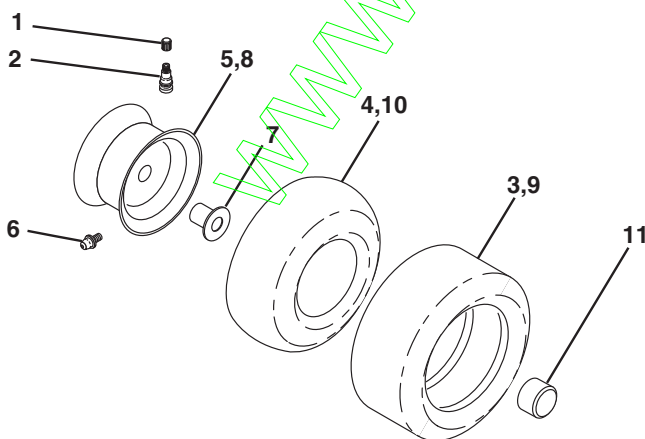

KEY NO.	PART NO.	DESCRIPTION
1	532 05 91-92	Cap Valve Tire
2	532 06 51-39	Stem Valve
3	532 13 74-22	Tire F Ts 15 X 6 - 6 Service
4	532 05 99-04	Tube Front (Service Item Only)
5	532 14 14-72	Rim Asm 6" front Service
6	532 12 49-57	Fitting Grease (Front Wheel Only)
7	532 12 49-59	Bearing Flange (Front Wheel Only)
8	532 14 12-68	Rim Asm 8" rear Service
9	532 13 27-03	Tire R Ts 18 x 8.5-8 C. Service
10	532 12 49-26	Tube Rear (Service Item Only)
11	532 17 50-39	Cap Axle Blk 1 50 X 1 00

**NOTE:** All component dimensions given in U.S. inches  
1 inch = 25.4 mm

# REPAIR PARTS

TRACTOR- -MODEL NO. 11-92 (P1136C), PRODUCT NO. 964 77 07-00  
ENGINE

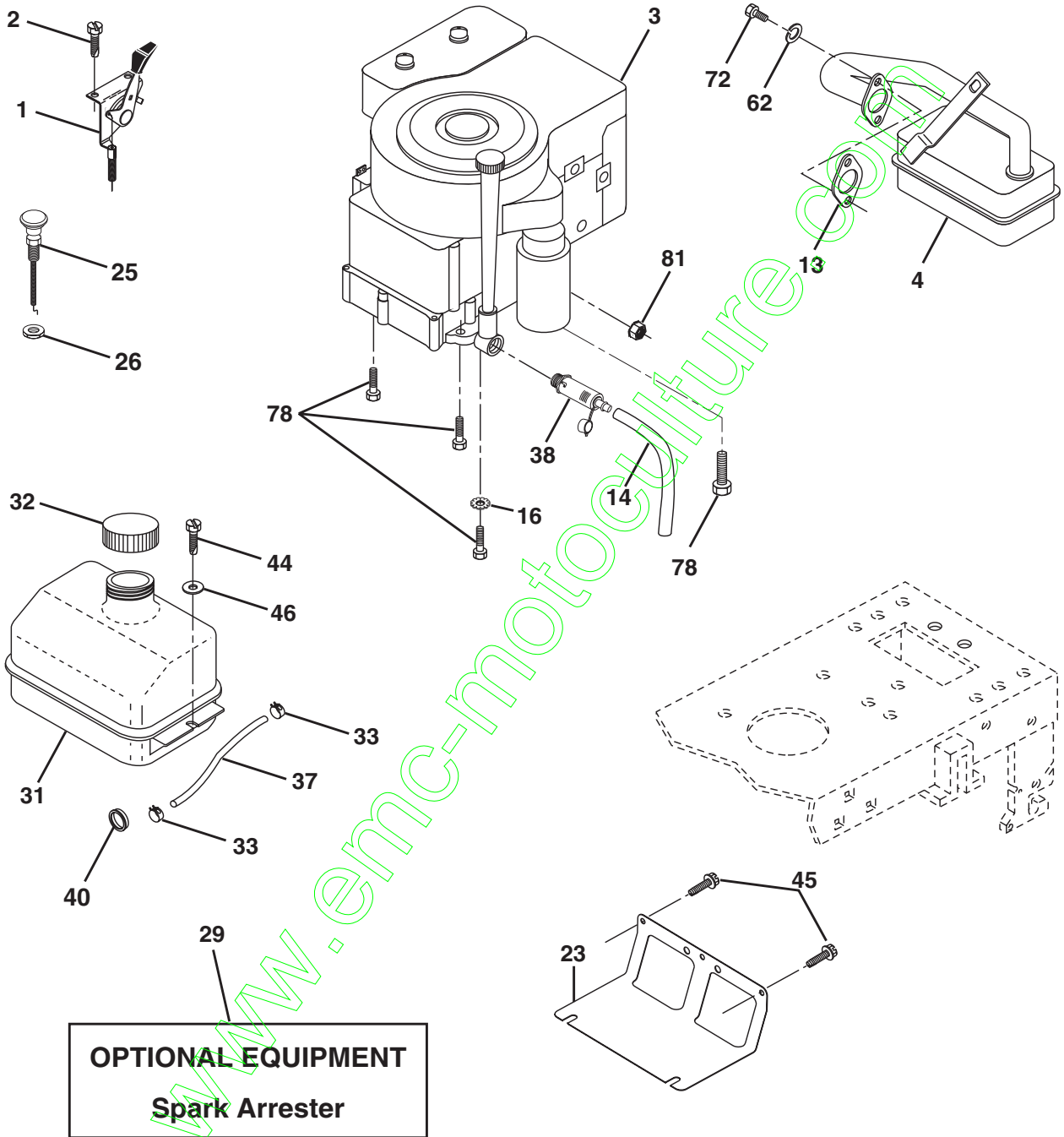

# REPAIR PARTS

TRACTOR- -MODEL NO. 11-92 (P1136C), PRODUCT NO. 964 77 07-00  
ENGINE

KEY NO.	PART NO.	DESCRIPTION
1	<b>532 17 05-51</b>	Control Th/ch Flag
2	817 72 04-08	Screw Hex Thd Cut 1/4-20 x 1/2
3	-----	Engine B&S Model No. 289707 (Order parts from engine manufacturer)
4	532 13 73-48	Muffler LT B&S 12/12 5 HP
13	532 16 52-91	Gasket Eng
14	532 14 84-56	Tube Drain Oil Easy
16	811 05 06-00	Washer Lock Ext Tooth 3/8
23	532 16 98-37	Shield Brn/Dbf Guard
25	<b>532 18 09-45</b>	Control Choke
26	<b>873 92 06-00</b>	Nut Keps 3/8-24 Unf
29	532 13 71-80	Kit Spark Arrecter
31	532 10 92-02	Tank Fuel Front 1.25
32	532 14 05-27	Cap Asm Fuel W/sym Vented
33	532 12 34-87	Clamp Hose Blk
37	532 13 70-40	Line Fuel 20"
38	532 14 83-15	Plug Oil Drain Easy
40	532 12 40-28	Bushing Snap Nyl Blk Fuel Line
44	817 67 04-12	Screw Hexwsh Thdrol 1/4-20 x 3/4
45	817 00 06-12	Screw Hexwsh Thdrol 3/8-16 x 3/4
46	819 09 14-16	Washer 9/32 x 7/8 x 16 Ga.
62	810 04 05-00	Washer Lock Hvy Hlcl Spr 5/16
72	871 07 05-12	Screw Hexhd Cap 5/16-18 x 3/4
78	817 06 06-20	Screw 3/8-16 x 1-1/4
81	873 51 04-00	Nut Keps Hex 1/4-20 UNC

**NOTE:** All component dimensions given in U.S. inches  
1 inch = 25.4 mm

# REPAIR PARTS

TRACTOR- -MODEL NO. 11-92 (P1136C), PRODUCT NO. 964 77 07-00  
MOWER LIFT

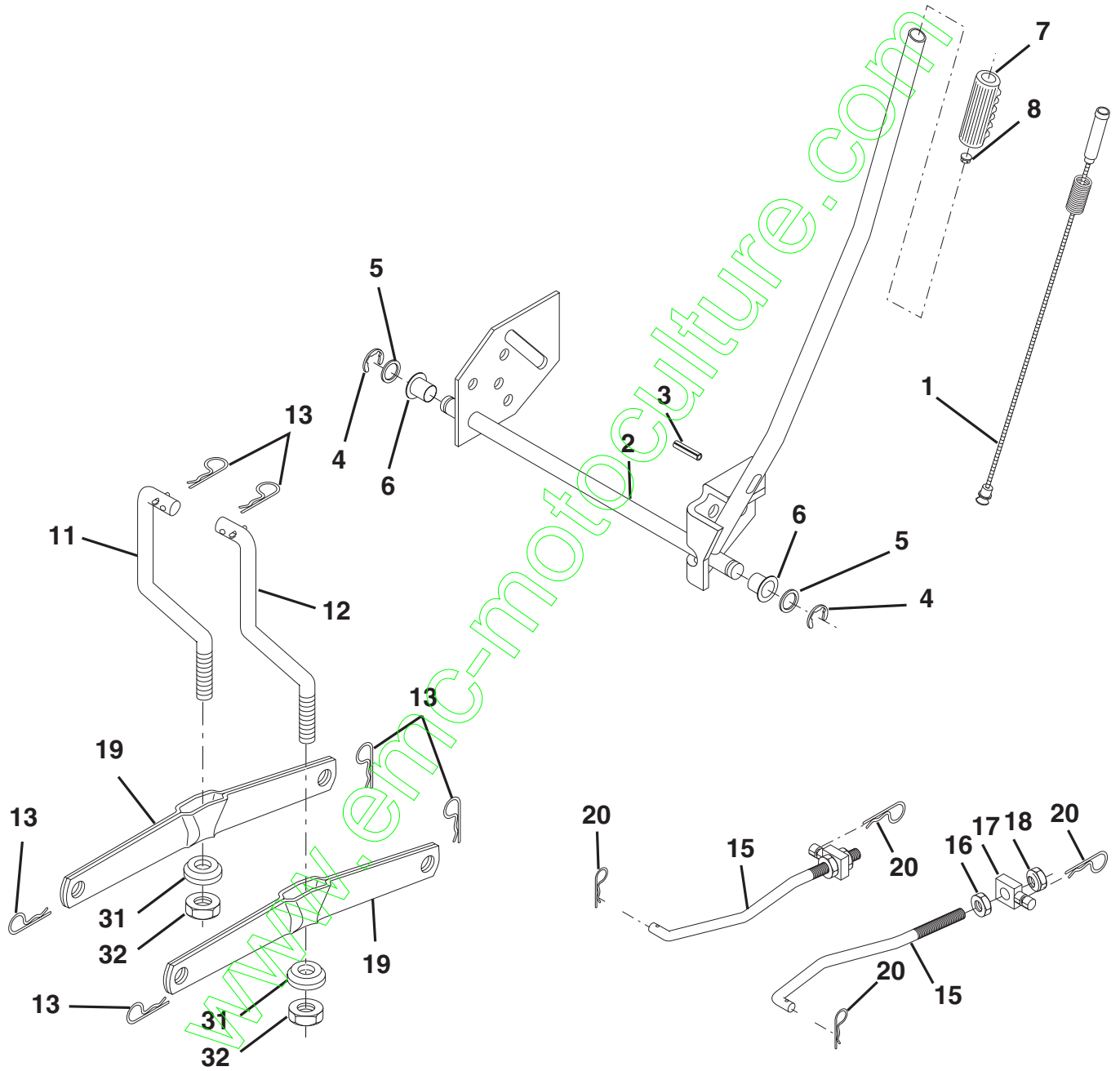

# REPAIR PARTS

TRACTOR- -MODEL NO. 11-92 (P1136C), PRODUCT NO. 964 77 07-00  
MOWER LIFT

KEY NO.	PART NO.	DESCRIPTION
1	532 1594-60	Wire Asm Inner W/Plunger
2	532 1594-71	Shaft Asm Lift
3	532 1057-67	Pin Groove
4	812 0000-02	E Ring #5133-62
5	81921 16-21	Washer PLTD 21/32 x 1 x 21 Ga
6	532 1201-83	Bearing Nylon Blk 629 Id
7	532 1094-13	Grip Handle Bicycle Matte Blk
8	532 1245-26	Button Plunger Black
11	532 1398-65	Link Lift LH
12	532 1398-66	Link Lift RH
13	532 1246-70	Retainer Spring
15	532 1732-88	Link Front
16	873 3508-00	Nut Jam Hex 1/2-13 Unc
17	532 1756-89	Trunnion
18	873 8008-00	Nut Lock W/Wsh 1/2-13 Unc
19	532 1398-68	Arm Suspension Rear
20	532 1635-52	Retainer Spring
31	532 1698-65	Bearing Pvt Lift
32	873 5406-00	Nut Crownlock 3/8-24

**NOTE:** All component dimensions given in U.S. inches  
1 inch = 25.4 mm

# REPAIR PARTS

TRACTOR- -MODEL NO. 11-92 (P1136C), PRODUCT NO. 964 77 07-00  
MOWER

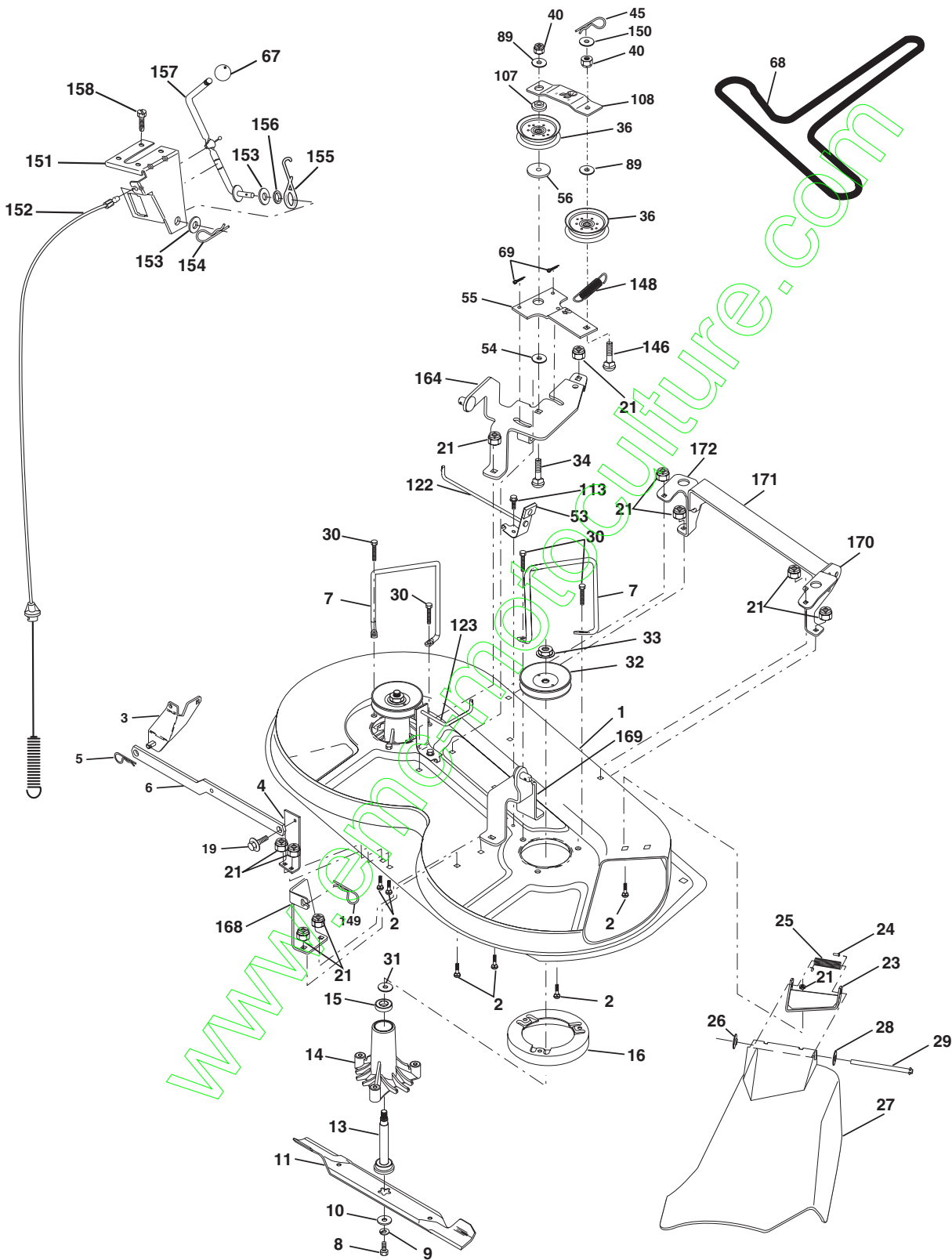



# REPAIR PARTS

TRACTOR- -MODEL NO. 11-92 (P1136C), PRODUCT NO. 964 77 07-00  
MOWER

KEY NO.	PART NO.	DESCRIPTION	KEY NO.	PART NO.	DESCRIPTION
1	532 17 45-95	Mower Deck Assembly	56	532 16 57-23	Spacer, Retainer
2	872 14 05-06	Bolt	67	532 10 69-32	Knob RD 3/8-16 Plstc Thd
3	532 13 80-17	Bracket Assembly, Sway Bar	68	<b>532 18 02-13</b>	Belt
4	532 17 56-54	Bracket Sway Bar	69	876 02 03-12	Pin, Cotter 3/32 x 3/4
5	532 12 46-70	Retainer Spring	89	819 13 16-12	Washer 13/32 x 1 x 12 Ga
6	532 17 80-24	Bar Sway Deck	107	532 13 35-02	Spacer, Retainer
7	532 14 06-08	Keeper Belt	108	532 13 35-03	Stiffener, Idler Arm
8	532 85 08-57	Bolt, Hex 3/8-24 x 1.25 Gr. 8	113	817 49 05-08	Screw Thdrol 5/16-18 x 1/2
9	810 03 06-00	Washer, Lock Hvy Hlcl 3/8	122	532 17 45-05	Rod, Brake, LH
10	532 14 02-96	Washer, Hardened	123	532 17 45-04	Rod, Brake, RH
11	532 13 84-96	Blade, Mower	146	532 16 58-91	Bolt Carriage Idler
13	532 13 76-45	Shaft Assembly, Mandrel, Vented	148	532 16 90-22	Spring Return Idler
14	532 12 87-74	Housing, Mandrel, Vented	149	532 16 58-98	Retainer Spring Yellow Zinc
15	532 11 04-85	Bearing, Ball, Mandrel	150	819 09 12-16	Washer 9/32 x 3/4 x 16 Ga.
16	532 17 44-93	Stripper, Mower Deck	151	532 16 96-70	Bracket Clutch
19	532 13 28-27	Bolt, Shoulder	152	532 17 60-79	Cable Clutch
21	873 68 05-00	Nut Crownlock 5/16-18	153	532 16 96-74	Washer Flat 3/8" Type B
23	532 13 66-31	Bracket, Mower Deflector	154	532 16 96-75	Spring Retainer
24	532 10 53-04	Cap, Sleeve	155	532 16 96-71	Spring Retention Lever
25	532 12 37-13	Spring, Torsion, Deflector	156	532 16 96-72	Spacer
26	532 11 04-52	Nut, Push	157	532 16 96-69	Rod Clutch
27	532 17 61-62	Shield, Deflector	158	817 72 04-08	Screw Hex Thd Cut 1/4-20 x 1/2
28	819 11 10-16	Washer 11/32 x 5/8 x 16 Ga.	164	532 17 49-76	Bracket Asm Idler Support
29	532 12 19-80	Rod, Hinge	168	532 17 23-77	Bracket Deck Cable
30	532 17 39-84	Screw Thdrol	169	532 17 49-77	Bracket Asm Suspension
31	532 12 99-63	Washer, Spacer	170	532 17 23-59	Bracket Suspension RF
32	532 15 35-31	Pulley, Mandrel	171	532 16 52-37	Brace Support Susp. Frt
33	532 17 83-42	Nut, Toplock, Flanged	172	532 17 23-55	Bracket Suspension LF
34	872 11 06-14	Bolt Rdhd 3/8-16 x 1-3/4	--	532 13 07-94	Mandrel Assembly (Includes Housing, Shaft and Shaft Hardware Only - Pulley Not Included)
36	532 13 14-94	Pulley, Idler, Flat	--	<b>532 18 13-76</b>	Replacement Mower, Complete
40	873 68 06-00	Nut Crownlock 3/8-16			
45	532 12 47-88	Retainer, Spring			
53	532 13 08-40	Brake Assembly			
54	532 13 39-43	Washer, Hardened			
55	532 13 38-40	Idler Arm Assembly			

**NOTE:** All component dimensions given in U.S. inches  
1 inch = 25.4 mm

# TRACTOR- -MODEL NO. 11-92 (P1136C), PRODUCT NO. 964 77 07-00 SCHEMATIC

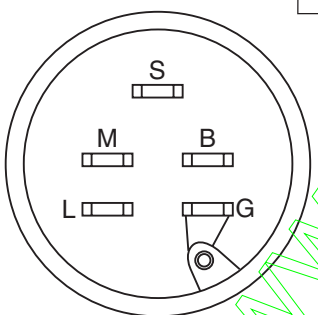
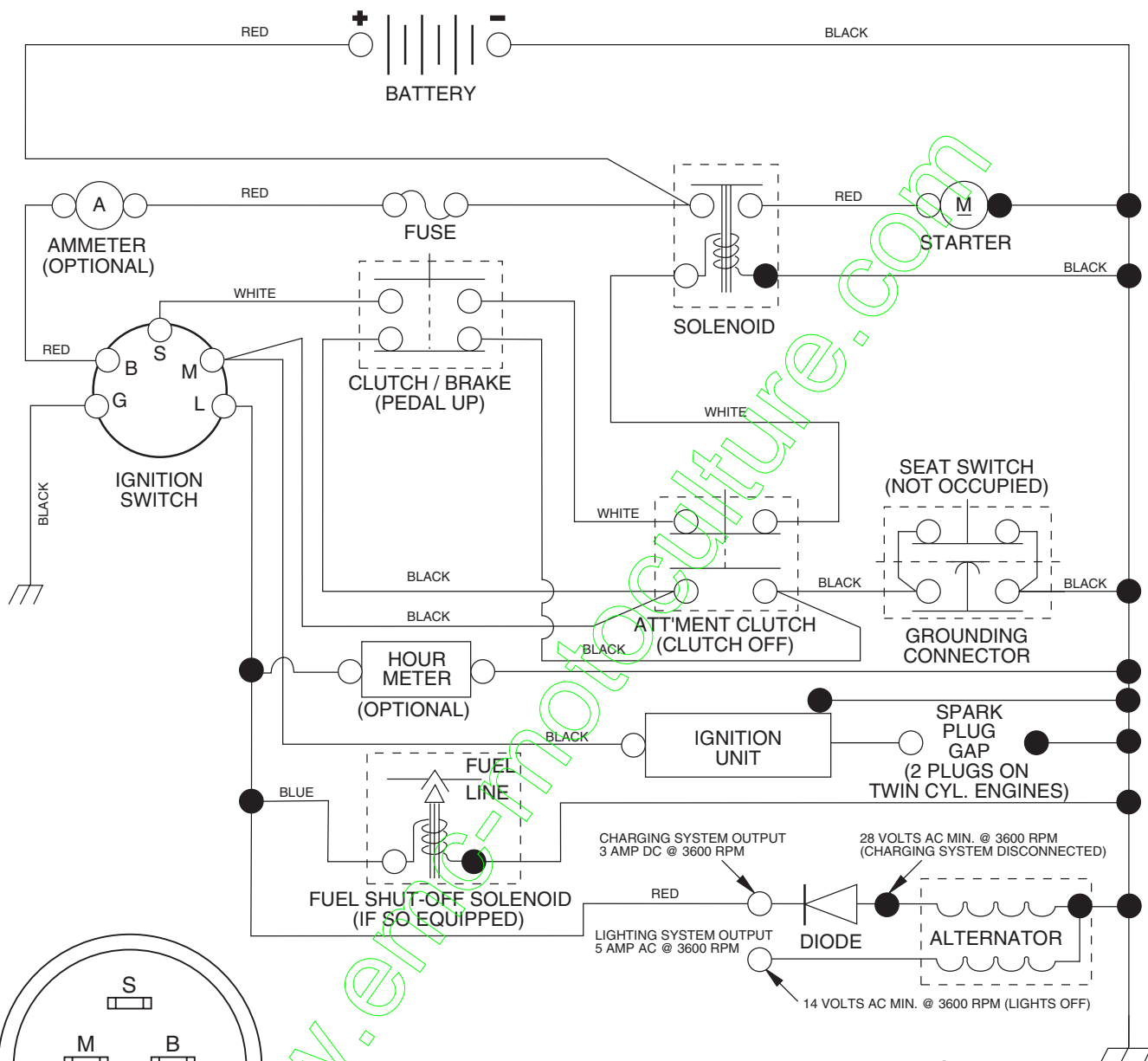

**IGNITION SWITCH**

POSITION	CIRCUIT
OFF	M + G
ON	B + L
START	B + S + L

**WIRING INSULATED CLIPS**  
**NOTE:** IF WIRING INSULATED CLIPS WERE REMOVED FOR SERVICING OF UNIT, THEY SHOULD BE REPLACED TO PROPERLY SECURE YOUR WIRING.

