

Position	Numéro de pièce	#	Appellation I	Appellation II
1	683-04474	1	NOIR	SCHWEISSTEIL:LACKIERT MTD QUAL
2	710-1690	2	VIS	MTD SPEC-100015 21.1441.46
3	711-1017	1	BOULON	FINISH:MTD SPEC-100015
4	712-0691	2	ECROU HEXAGONAL	MTD SPEC-100015 24.1426.14
5	714-0104	1	GOUPILLE	FINISH:PHOS AND OIL
6	723-0383	1	SANGLE POUR GOULOTTE D'EJECTI	FINISH:
7	731-06408	1	BOUCHON MULCHING	FINISH:SCHWARZ
8	736-0343	2	RONDELLE .330 ID X 1.25 X .12	FINISH:MTD 711-100015
9	747-05127	1	TRINGLE SUPPORT GOILOTE	KIT:FINISH:SPEC-100015
10	749-04231B	1	ROHR:MULCH PLUG:Ø22x1.0x483mm	DIN 2394 ST 35 LACKIERT
11	783-04581	1	ARRAT	FINISH:LACKIERT

www.emc-motoculture.com

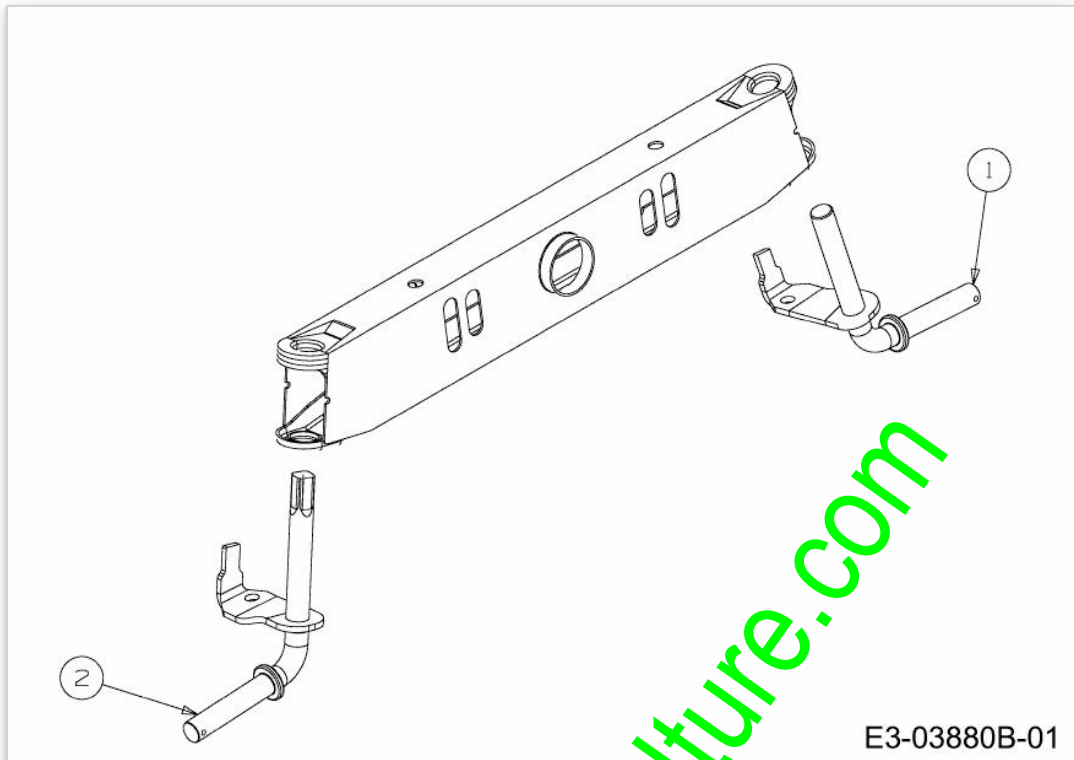

E3-03880B-01

www.emc-motoculture.com

Position	Numéro de lapièce	#	Appellation I	Appellation II
1	638-04014A-S	1	FUSEE GAUCHE	SCHWARZ
2	638-04013637	1	FUSEE DROITE	SCHWEISSTEIL:LACKIERT

www.emc-motoculture.com

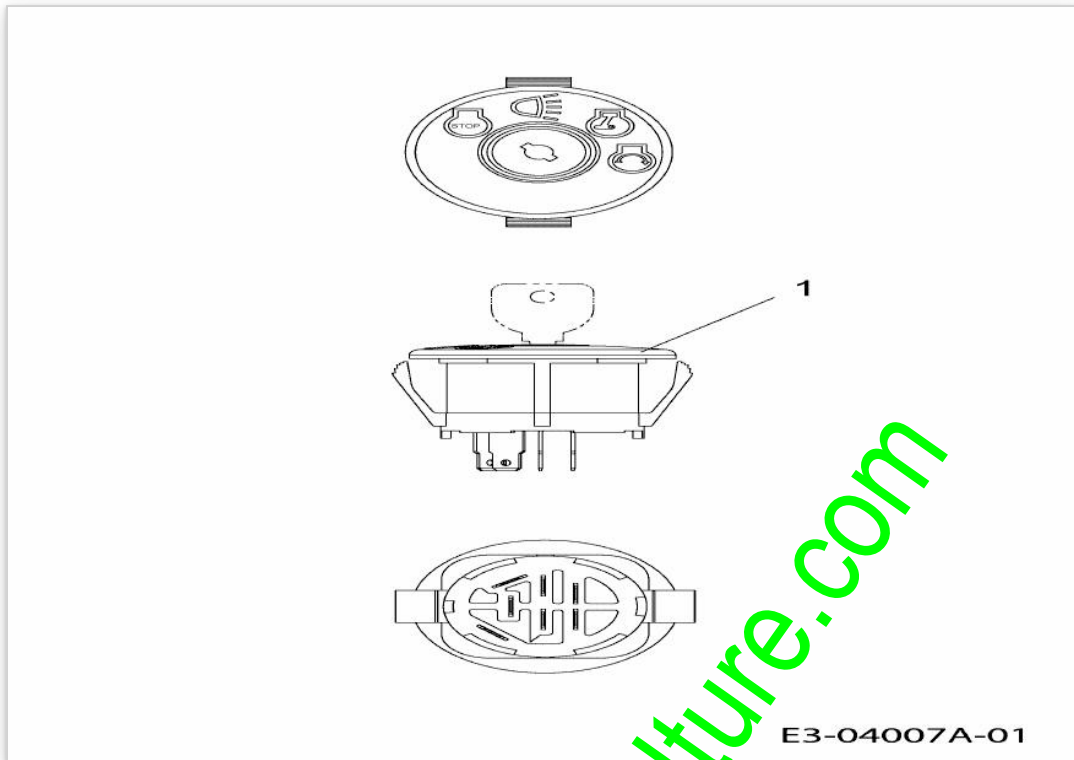

E3-04007A-01

www.emc-motoculture.com

Position	Numéro de lapièce	#	Appellation I	Appellation II
1	725-1741	1	CONTACTEUR A CLE	FINISH: 925-1741

www.emc-motoculture.com

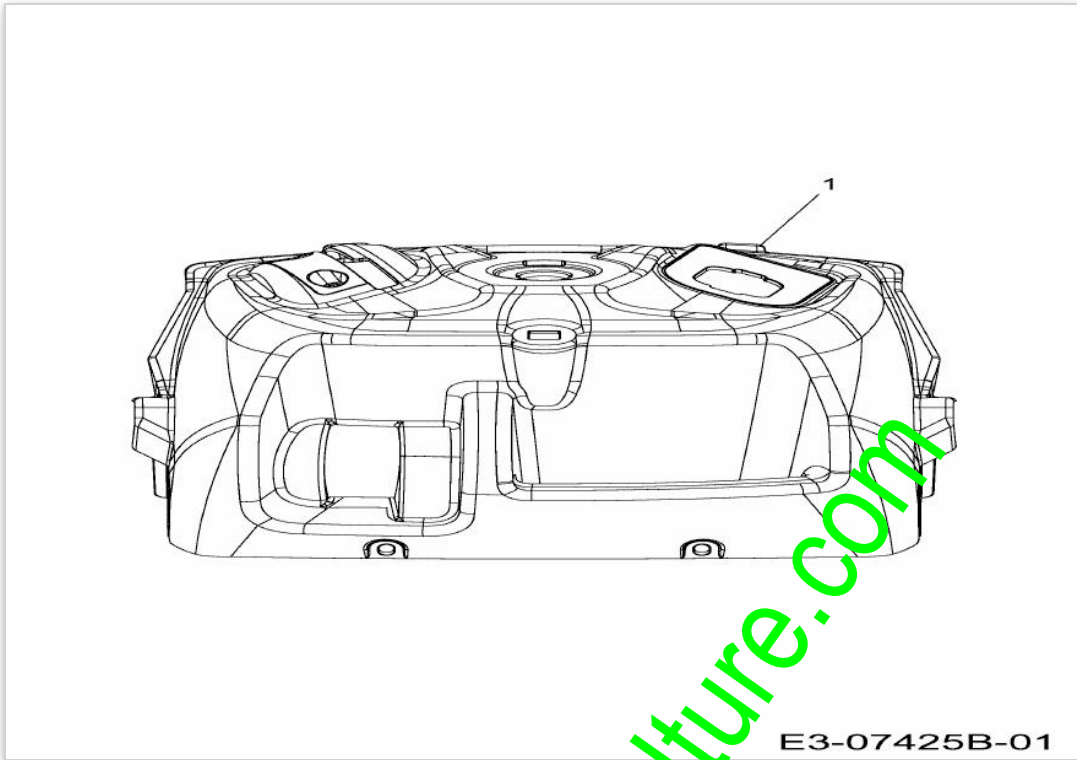

E3-07425B-01

www.emc-motoculture.com

Position	Numéro de lapièce	#	Appellation I	Appellation II
1	731-08054A	1	TABLEAU DE BORD	FINISH:KUNSTSTOFF SCHWARZ

www.emc-motoculture.com

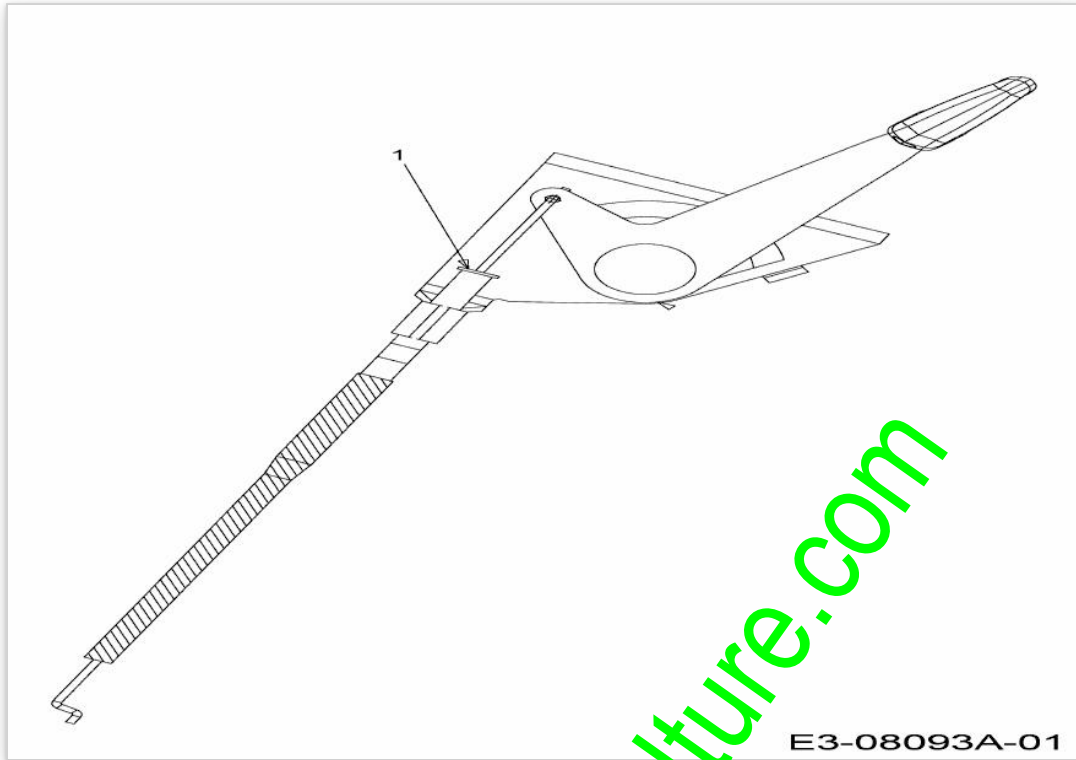

E3-08093A-01

www.emc-motoculture.com

Position	Numéro de lapièce	#	Appellation I	Appellation II
1	746-04591	1	CABLE GAZ	MIT BEDIENUNGSHEBEL

www.emc-motoculture.com

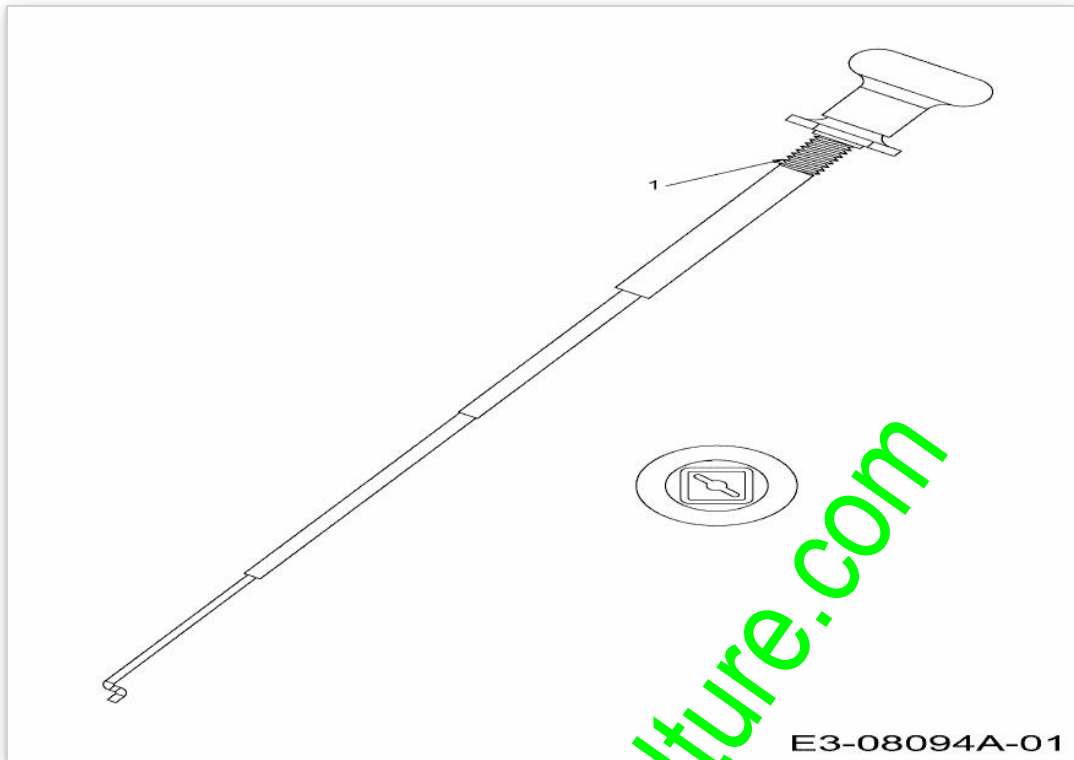

E3-08094A-01

www.emc-motoculture.com

Position	Numéro de lapièce	#	Appellation I	Appellation II
1	746-04847	1	CABLE STARTER	FINISH:ZUGKNOPF SCHWARZ

www.emc-motoculture.com

ab 01.06.2013
from 01.06.2013
à partir du 01.06.2013

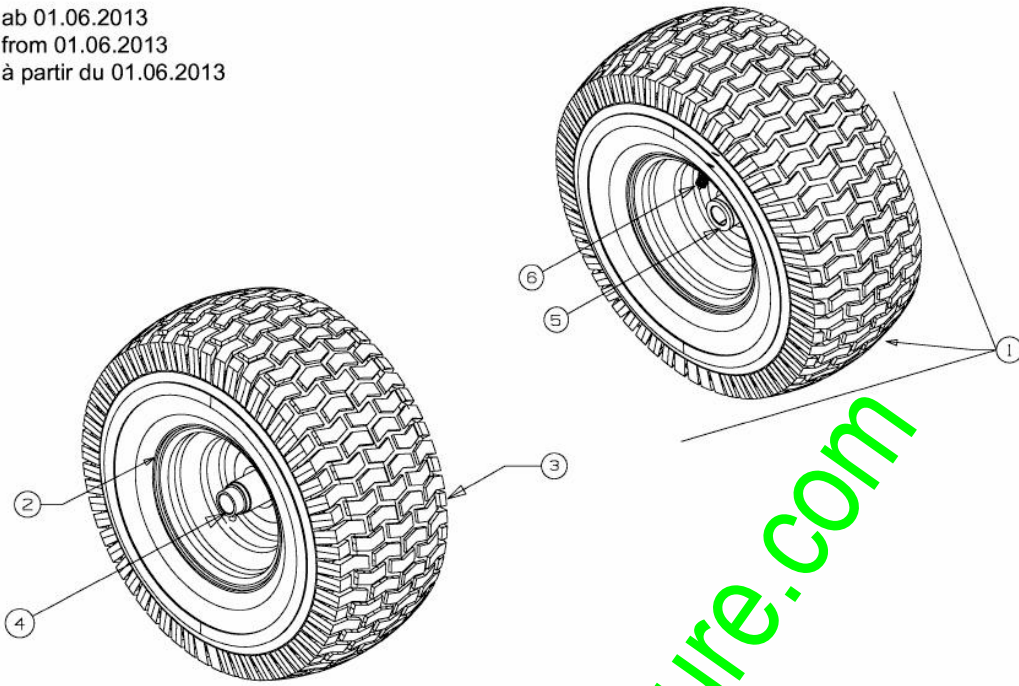

E3-02085C-01

www.emc-motoculture.com

Position	Numéro de lapièce	#	Appellation I	Appellation II
1	634-04086	2	ROUE CPLT	SHL
2	634-04081	2	JANTE CPLT	GLEITLAGER SCHWEIßTEIL
3	734-1731	2	PNEU 15X600X6 DICO MULTI-TRAC	SQ SHOULDER:TURF SAVER
4	741-0990B	2	BAGUE DE ROUE AVEC GRAISSEUR	m.SCHMIERNIPPEL:FINISH SCHWARZ
5	741-0516B	2	BAGUE DE ROUE .760x1.00x1.20	FINISH:SCHWARZ
6	734-0255	2	VALVE:PNEU	TR 412-P / 32.6mm / 934-0255

www.emc-motoculture.com

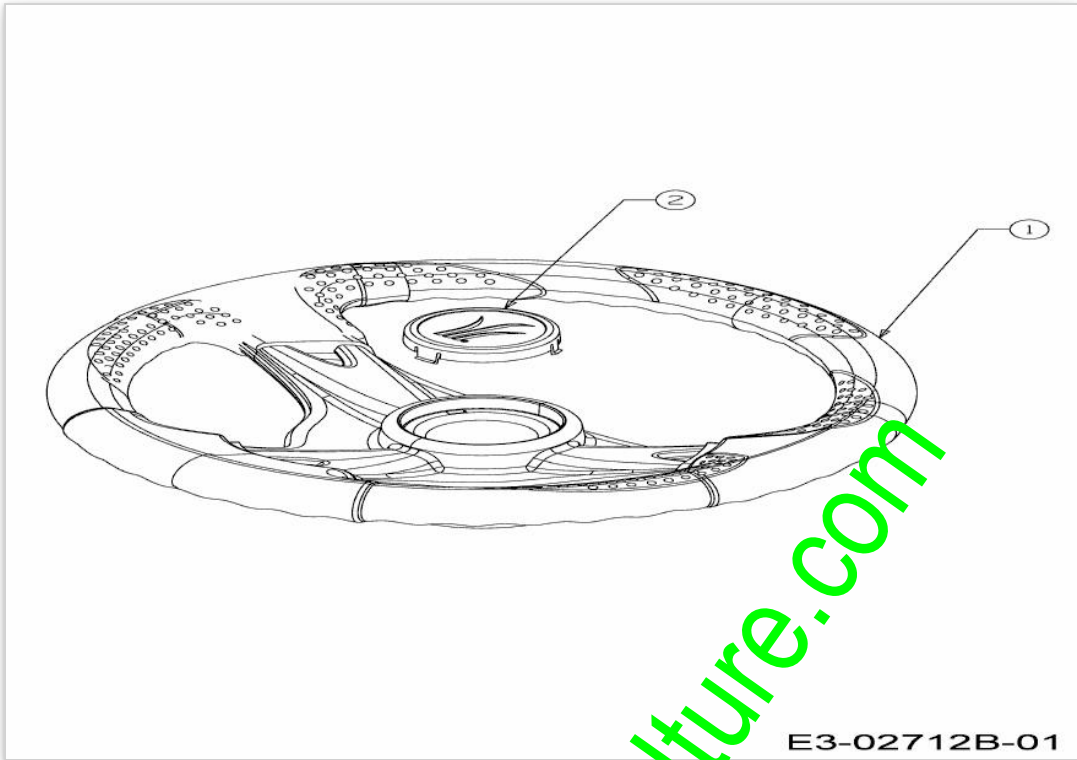

E3-02712B-01

www.emc-motoculture.com

Position	Numéro de lapièce	#	Appellation I	Appellation II
1	631-04008B	1	VOLANT CPL.:3 RAYONS:12"	SOFTGRIP
2	731-04040	1	COUVERCLE DE VOLANT	Ø 60mm:KUNSTSTOFF SCHWARZ

www.emc-motoculture.com

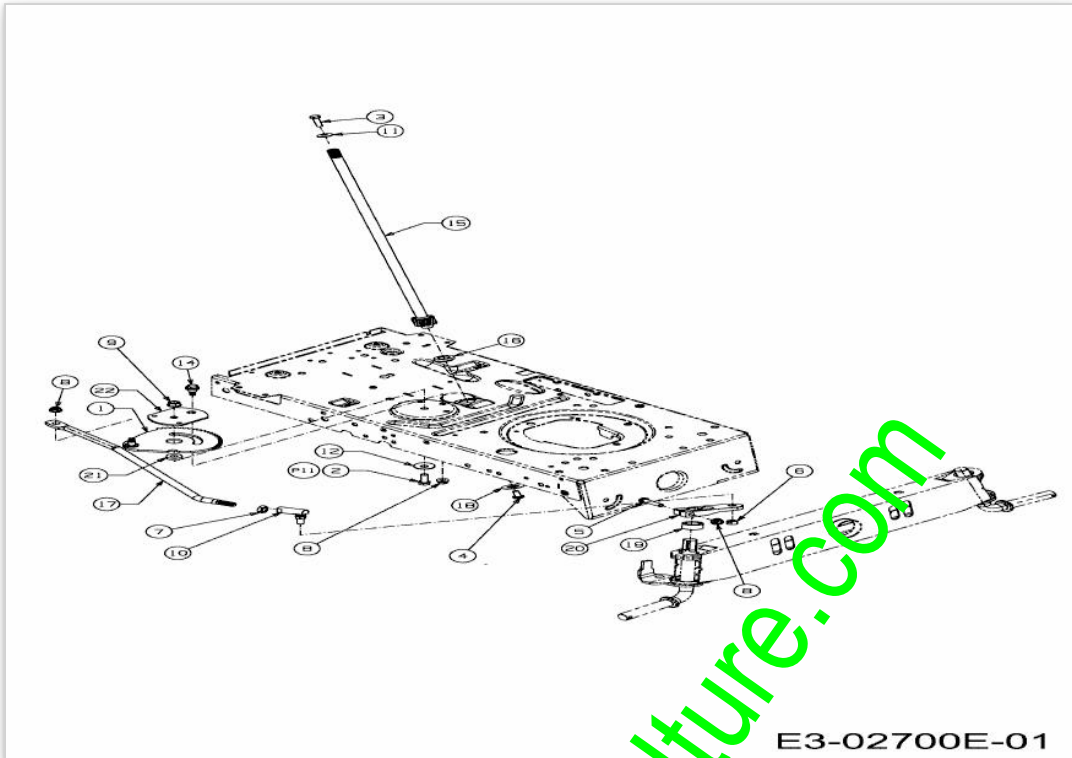

www.emc-motoculture.com

Position	Numéro de pièce	#	Appellation I	Appellation II
1	617-04094	1	SEGMENT DE DIRECTION	SCHWEISSTEIL:PHOS & OIL
2	710-0514	1	VIS HEX.:3/8-16:1.00:GR5:STD	FINISH:MTD SPEC-100015
3	710-0643	1	VIS HEX.: 5/16-18:1.00:GR5	FINISH:MTD SPEC-100015
4	710-1309	1	VIS	FINISH:MTD SPEC-100015
5	710-3180	1	VIS HEX. 5/16-18:1.75:GR5:STD	FINISH:SPEC-100015
6	712-0214	1	ECROU	FINISH:SPEC-100015
7	712-0240	1	ECROU HEX.: 7/16-20:GR2	FINISH:MTD SPEC-100015
8	712-04063	3	ECROU HEX. AVEC FLANC	FINISH:MTD SPEC-100015
9	712-0431	1	ECROU STOP 3/8-16:GRF	FINISH:MTD SPEC-100015
10	723-0448A	1	ROTULE DE DIRECTION 7/16-20	FINISH:MTD SPEC-100015
11	736-0242	1	RONDELLE CONIQUE.340X.872X.060	FINISH:MTD SPEC-100016
12	736-0331	1	RONDELLE CONIQUE	FINISH:MTD SPEC-100016
14	738-04141	1	AXE	FINISH:SPEC-100015
15	738-05078	1	ARBRE DE DIRECTION	FINISH:PHOS & OIL
16	741-04124	1	PALIER DE BRIDE	FINISH:PLAIN
17	747-05385	1	TRINGLE DE DIRECTION	FINISH:701-01007
18	748-0389	1	BAGUE	FINISH:GEÖLT
19	748-04068	1	DOUILLE .71 ODX.125 ODX.56 LG	FINISH:SPEC-100015
20	748-04278	1		
21	750-06192	1	ENTRETOISE	FINISH:DAMPFBEBANDELT
22	783-08577	1	PLAQUE STABILISATEUR DE SECMEN	FINISH:PHOS & OIL

www.epc-motoculture.com

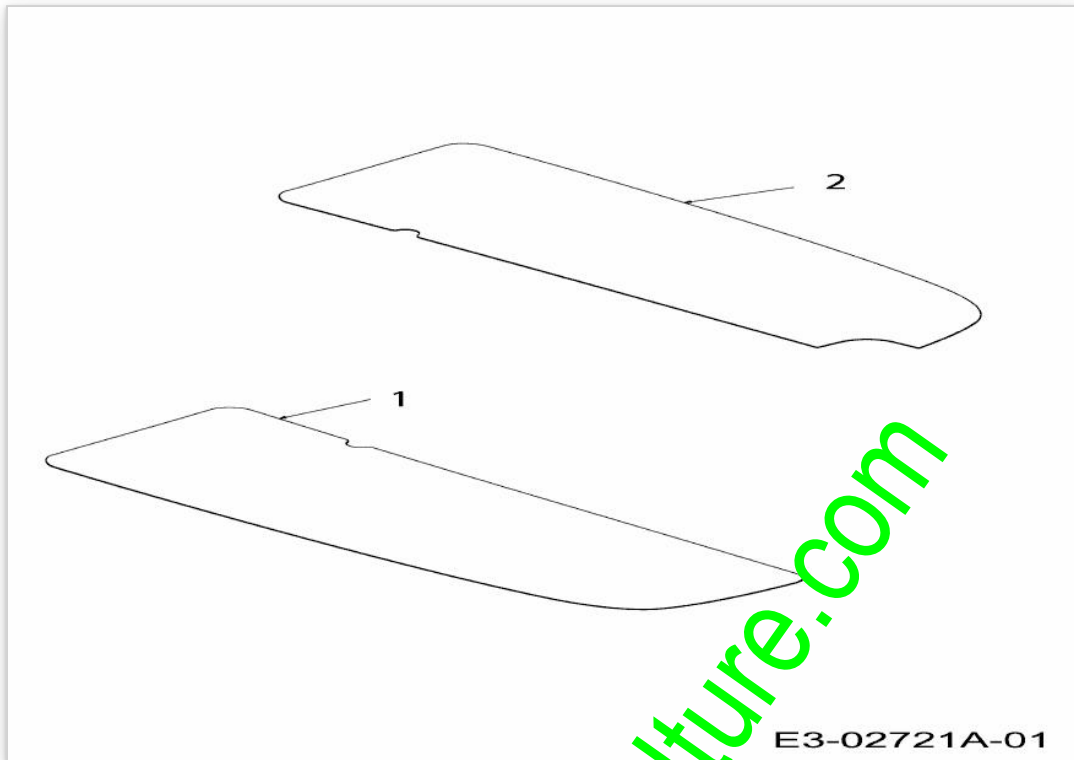

www.emc-motoculture.com

E3-02721A-01

Position	Numéro de pièce	#	Appellation I	Appellation II
1	723-04025	1	MARCHE PIED DROITE	FARBE: SCHWARZ
2	723-04026	1	MARCHE PIED GAUCHE	FARBE: SCHWARZ

www.emc-motoculture.com

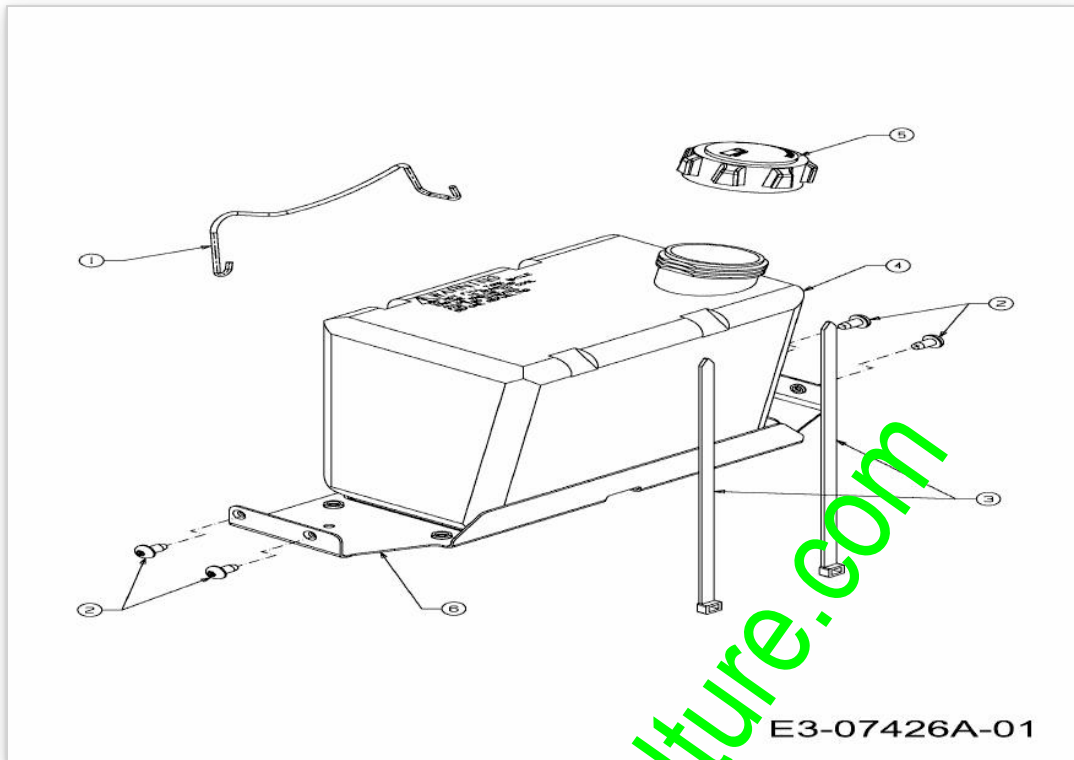

E3-07426A-01

Position	Numéro de pièce	#	Appellation I	Appellation II
1	683-04448637	1	TRINGLE SUPPORT BATTERIE	683-04448-0637
2	710-05070	4	VIS	FINISH: SCHWARZ SPEC 701-01010
3	726-0230	2	COLLIER	FINISH: SCHWARZ
4	751-0553	1	RESERVOIR 5 L ENV.	FINISH: NATUR SIEHE ZG.
5	751-0603A	1	BOUCHON ESSENCE	KUNSTSTOFF SCHWARZ -OBSOLETE-
6	783-07083637	1	SUPPORT DE RESERVOIR ESSENCE	FINISH: LACKIERT MTD QUALITÄT

www.emc-motoculture.com

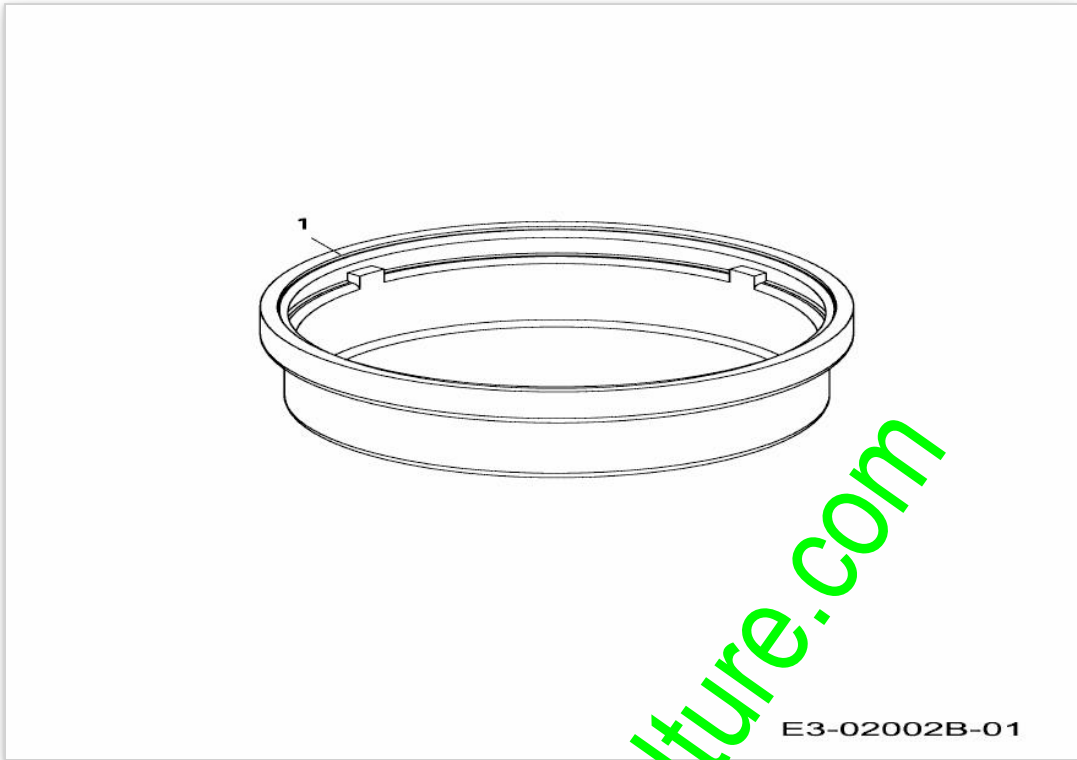

E3-02002B-01

www.emc-motoculture.com

Position	Numéro de lapièce	#	Appellation I	Appellation II
1	731-0484A	2	ENJOLIVEUR DEVANT	KUNSTSTOFF SCHWARZ 931-0484A

www.emc-motoculture.com

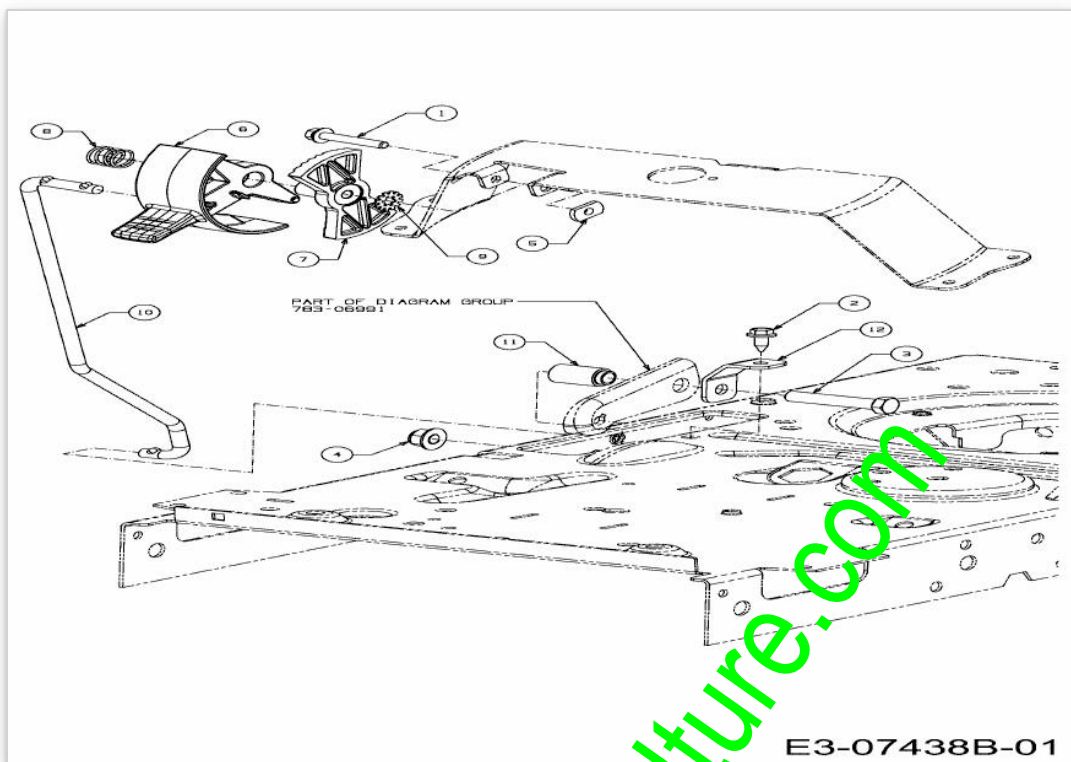

www.emc-motoculture.com

Position	Numéro de pièce	#	Appellation I	Appellation II
1	710-05237	1	VIS	FINISH:MTD SPEC-100015
2	710-1652	1	VIS HEX. TT:1/4-20:.625:HXINDW	FINISH:MTD-SPEC-100016 TYPE 1
3	710-3144	1	VIS HEX.: 3/8-16:2.00:GR5:STD	FINISH:SPEC-100015 910-3144
4	712-04065	1	ECROU HEXAGONAL	FINISH:SPEC-100015 912-04065
5	712-0414	1	ECROU 1/4-20	FINISH:PLAIN
6	731-07885B	1	POIGNEE DE VITESSE	FINISH:KUNSTSTOFF GELB
7	731-07965A	1	INDEX	FINISH:PLAIN (SCHWARZ)
8	732-04877	1	RESSORT	FINISH:MTD SPEC-100015
9	736-3006	1	RONDELLE 1/4 X -75	FINISH:SPEC-100016
10	747-05398	1	TRINGLE DE VITESSE	FINISH:SPEC-100015
11	750-04465C	1	ENTRETOISE	FINISH:GEÖLT
12	783-06823	1	SUPPORT	KONTROLLHEBEL:VERZ.SIEHE ZG.

www.emc-motoculture.com

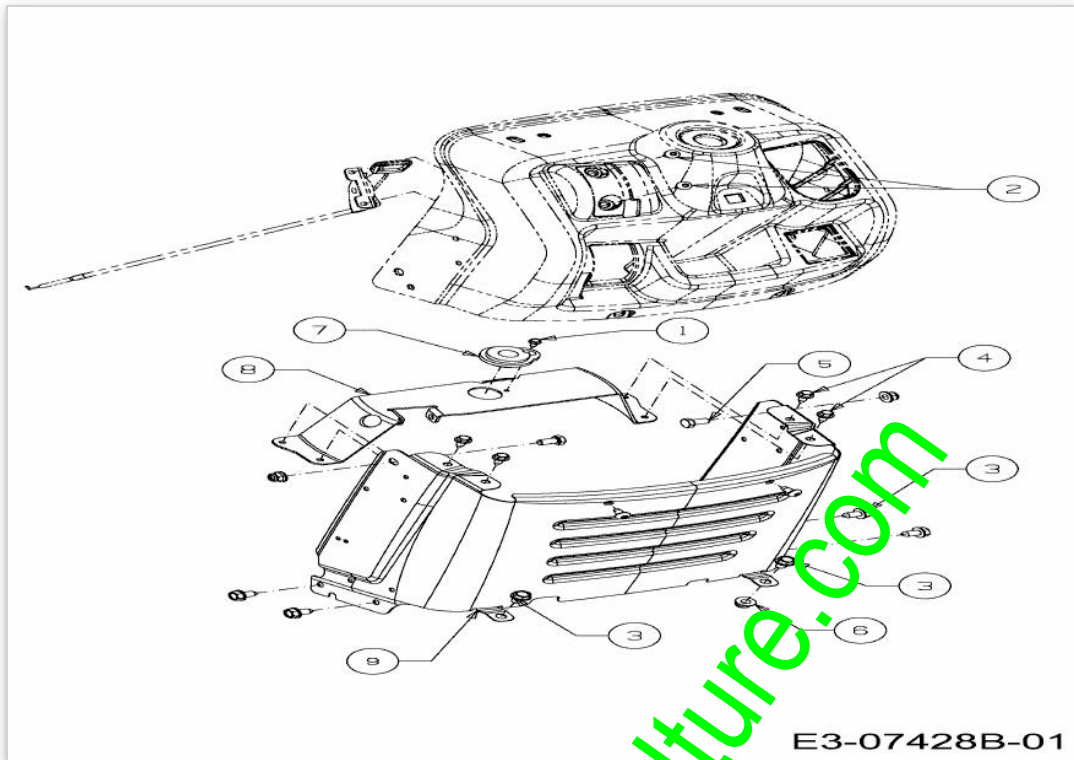

www.emc-motoculture.com

Position	Numéro de lapièce	#	Appellation I	Appellation II
1	710-0224	1	VIS PARK:#10- 16:0.500:HXINDWSH	FINISH:MTD SPEC-100016 TYPE 1
2	710-05070	2	VIS	FINISH:SCHWARZ SPEC 701-01010
3	710-0604A	6	VIS 5/16-18:0.625	FINISH:MTD SPEC-100016 TYPE 1
4	710-1652	4	VIS HEX. TT:1/4- 20:.625:HXINDW	FINISH:MTD-SPEC-100016 TYPE 1
5	710-3025	2	VIS	FINISH:MTD SPEC-100015
6	712-04063	2	ECROU HEX. AVEC FLANC	FINISH:MTD SPEC-100015
7	741-0587	1	SUPPORT	FINISH:NAT UR
8	783-06785A	1		
9	783-06811B	1		

www.emc-motoculture.com

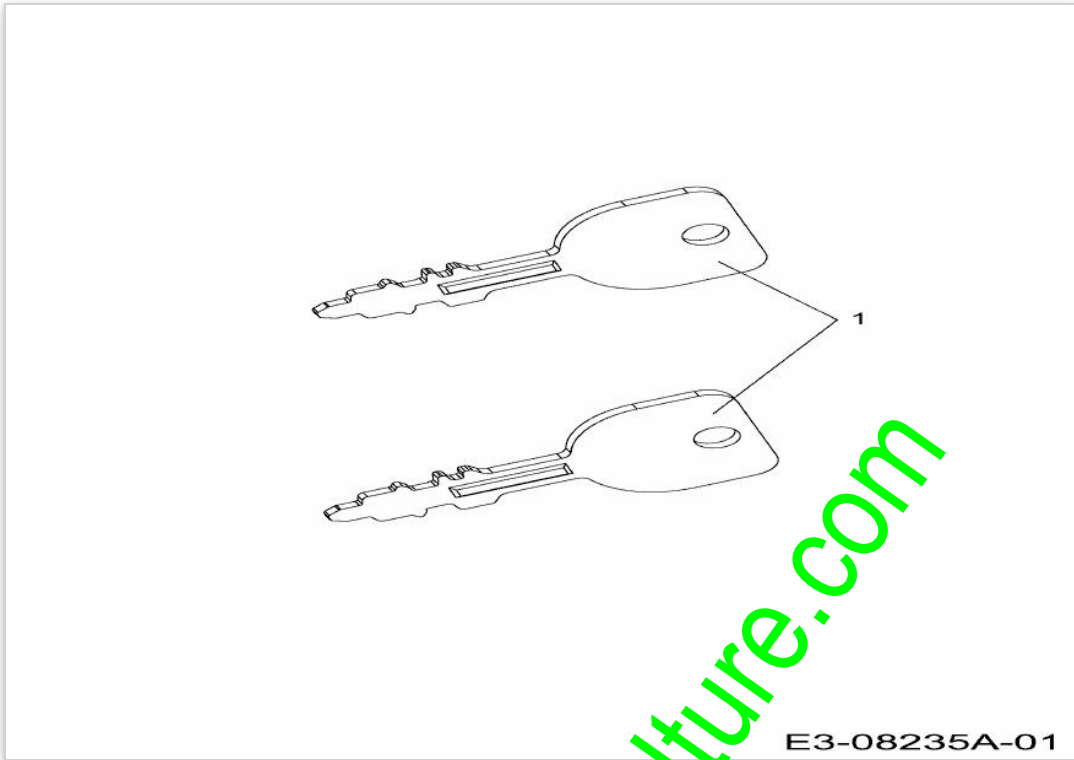

E3-08235A-01

www.emc-motoculture.com

Position	Numéro de pièce	#	Appellation I	Appellation II
1	725-1744A	2	CLE DE CONTACT	FINISH:

www.emc-motoculture.com

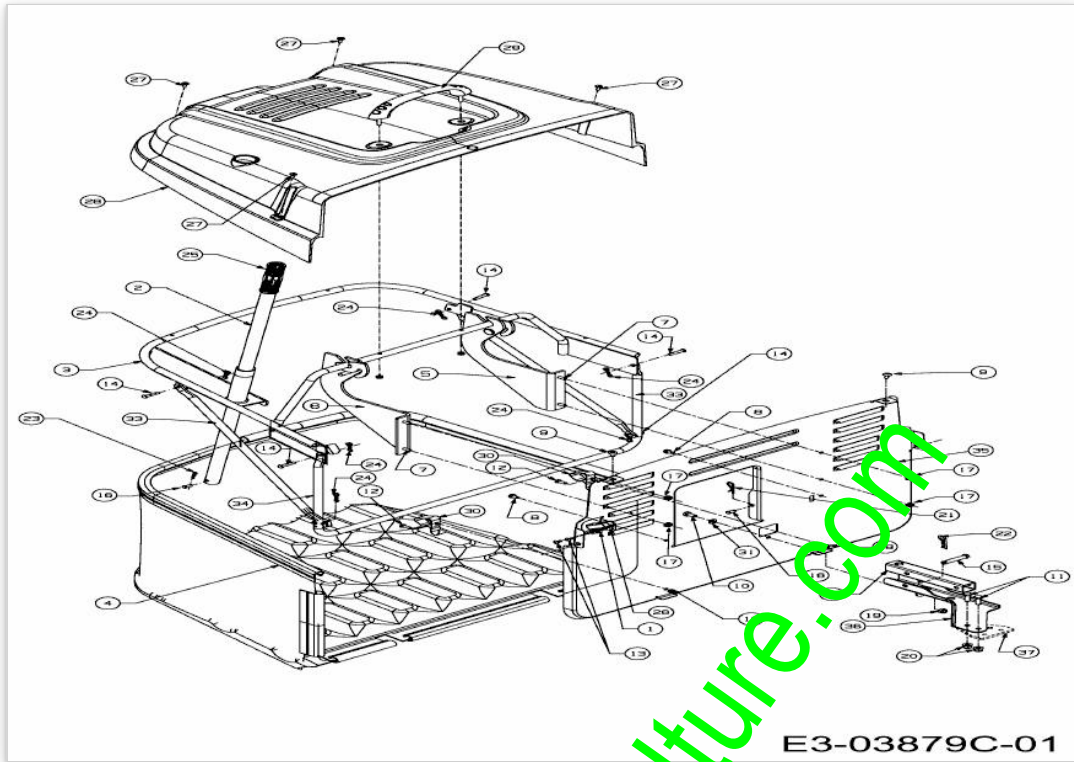

www.emc-motoculture.com

Position	Numéro de pièce	#	Appellation I	Appellation II
1	17962	1	PLAQUE DE SUPP. P. COMMUTATEUR	FINISH:WIE GESTANZT
2	649-04052	1	STAHLROHR VST:HEBEL:GRSBG:500	SCHWEISSTEIL:FINISH:LACKIERT
3	649-04076A-S	1	ARMATURE DE BAC	SCHWEISSTEIL:FINISH LACKIERT
4	664-04085	1	TISSU BAC DE RAMASSAGE	700:FINISH SCHWARZ
5	683-04421	1	EINHÄNGEKONSOLE VOLLST:LINKS	SCHWEISSTEIL:FINISH:LACKIERT
6	683-04422	1	EINHÄNGEKONSOLE VOLLST:RECHTS	SCHWEISSTEIL:FINISH:LACKIERT
7	710-04666	4	VIS HEXAGONALE	FINISH:MTD SPEC-100015
8	710-0599	2	VIS A SIX PANS CREUX	FINISH:MTD SPEC-101617
9	710-1017	2	VIS	FINISH:MTD SPEC-100016
10	710-1376	1	VIS A SIX PANS CREUX	FINISH:SPEC-100015 21.1441.68
11	710-1682	2	VIS	FINISH:SPEC-100015 21.1441.72
12	710-1690	2	VIS	MTD SPEC-100015 21.1441.46
13	710-1760	2	VIS	PHOS & OIL (ähnlich 710-0779A)
14	711-04138	6	GOUJON ; ÜPINGLER .25DIAx1.25L	FINISH:MTD SPEC-100015
15	711-0679A	1	GOUJON ; ÜPINGLER	GR5:FINISH MTD SPEC-100015
16	711-0701	3	GOUJON	FINISH:MTD SPEC-100015
17	712-04064	4	ECROU HEXAGONAL	FINISH:SPEC-100015 912-04064
18	712-0691	4	ECROU HEXAGONAL	MTD SPEC-100015 24.1426.14
19	712-0692	1	ECROU HEXAGONAL 24.1426.18	FINISH:SPEC-100015 24.1426.18
20	712-0714	2	ECROU	FINISH:MTD SPEC-100015
21	714-0145	2	GOUPILLE	FINISH:SPEC-701-01006
22	714-0147	1	GOUPILLE ; RESSORT:.125 X 1.75	FINISH:MTD SPEC-701-01006
23	714-04033	1	GOUPILLE FENDUE .072 x.92 LG	FINISH: MTD SPEC-100016
24	714-04040	6	GOUPILLE	FINISH:ASTM F1941 FE/ZN 3AN
25	720-0204	1	POIGNEE:1.0 ID x 4.7 LG	FINISH:Schwarz
26	725-04039	1	SECURITE	FINISH:GRAY/BLACK 925-04039
27	728-04044	4	RIVET	WÜRTH #093614816
28	731-06106	1	COUVERCLE DE BAC	FINISH:KUNSTSTOFF SCHWARZ
29	731-06163	1	POIGNEE	FINISH:Schwarz
30	732-0838A	2	RESSORT CLIPS DE BAC	VERSCHLUSS:FINISH SPEC-100015
31	736-0700	1	RONDELLE A8.4 DIN 125	MTD SPEC-100015 24.6481.18

Position	Numéro de lapièce	#	Appellation I	Appellation II
32	749-04013A	1	4KT- ROHR:ANHÄNGEKUPPLUNG	30x30mmx179.39mm LG ST37:LACK
33	749-04108	2	KREUZ- VERBINDUNGSROHR:BAG 250L	FINISH:LACKIERT 500 MR
34	749-04418	1	ROHRRAHMEN:VORN:200L	FINISH:LACKIERT
35	783-05731	1	HECKPLATTE:E/N-DECK:LT5	FINISH:LACKIERT MTD QUALITÄT
36	783-05801A	1	SUPPORT	FINISH:LACKIERT MTD QUALITÄT
37	783-1363	1	PLAQUE SUPPORT	FINISH:BLAU CHROMATIEREN *

www.emc-motoculture.com

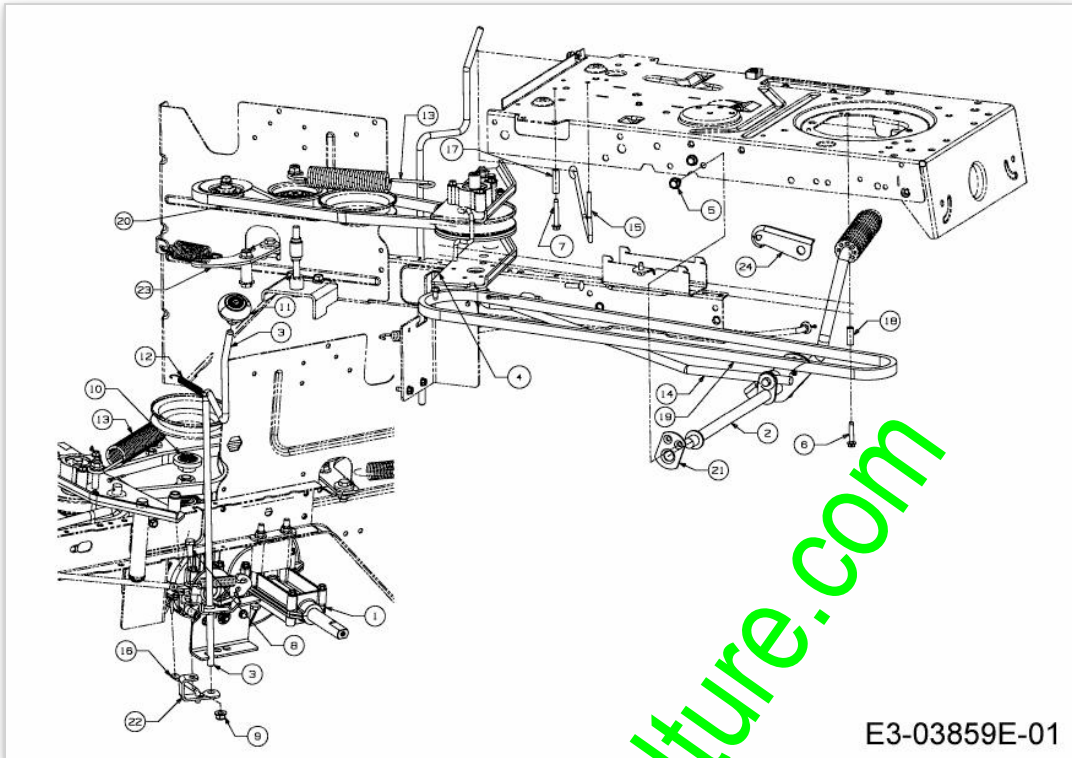

E3-03859E-01

Position	Numéro de pièce	#	Appellation I	Appellation II
1	092.60.138	1	SERVICE KIT LT-5 BOÎTE	E-TEIL-SET
2	647-04132A	1	PEDAL VOLLST:TRANS:RR DIS LT-5	SCHWEISSTEIL:LACKIERT
3	647-04140A	1	LEVIER INVERSEUR	FINISH:BLAU CHROMATIEREN *
4	683-04429	1	SPANNROLLENTÄGER VST:VARI:LT5	HECKAUSWURF:FINISH LACKIERT
5	710-0604A	2	VIS 5/16-18:0.625	FINISH:MTD SPEC-100016 TYPE 1
6	710-0809	1	VIS HEX. TT:1/4-20:1.250:HXIND	FINISH:MTD SPEC-100016 TYPE 1
7	710-1325	1	VIS HEXAGONALE	FINISH:SPEC-100016 TYPE 1
8	710-3008	1	VIS 5/16-18:.75:GR5:STD	SPEC-701-01006 or.SPEC-100015
9	712-04063	1	ECROU HEX. AVEC FLANC	FINISH:MTD SPEC-100015
10	718-04407	1	MOYEU: POULIE:5/8 DENTELURE	VERZÄHNUNG
11	720-04028	1	POIGNEE INVERSEUR	FINISH:SCHWARZ
12	732-04488	1	RESSORT DE TRACTION	FINISH:701-01006
13	732-04517	1	RESSORT	FINISH:PHOS AND OIL
14	747-04780	1	TRINGLE	LT-5 FINISH:MTD STD 100015
15	747-04803	1	TIGE	FINISH:LACKIERT
16	747-04850	1	TIGE	LT-5 HECKAUSWURF:701-01000
17	750-04456	1	ENTRETOISE	FINISH:MTD SPEC-100015
18	750-0566A	1	ENTRETOISE	FINISH:MTD SPEC-100015
19	754-04211	1	COURROIE MOTEUR VARIATEUR	POLY
20	754-04268	1	COURROIE VARIATEUR PONT LT5	POLY
21	783-04536B	1	STÜTZBLECH:PEDAL:LT-5	FINISH:LACKIERT MTD QUALITÄT
22	783-05853C	1	PATTE	FINISH:MTD STD SPEC-100015
23	783-06623	1	SUPPORT	FINISH:MTD SPEC-100015
24	783-06991-Z	1	SUPPORT	FINISH:MTD SPEC-100015

Position	Numéro de pièce	#	Appellation I	Appellation II
1	611-04096	1	FOURCHETTE	PRESSTEIL:FINISH:
8	710-0227	2	VIS	FINISH:MTD SPEC-100016 TYPE 1
9	710-04731	1	VIS	FINISH:MTD SPEC-100016
11	710-1325	17	VIS HEXAGONALE	FINISH:SPEC-100016 TYPE 1
12	717-0678	1	PLAQUETTE DE FREIN	FINISH:
13	719-04358	1	CARTER INFERIEUR	FINISH:WIE GEGOSSEN
14	721-0213	1	JOINT SPI .625x.812x.094	FINISH:
15	725-1644	1	INTERRUPTEUR DE SÛCURITÛ	FINISH:MTD SPEC-100015
16	726-0320	1	PLAQUE D'ISOLATION	FINISH:NATUR ODER SCHWARZ
17	732-04485A	1	RESSORT	FINISH:PHOS AND OIL SIEHE ZG.
18	736-0342	1	RONDELLE PLATE .283 x.75 x.030	FINISH:MTD STD 701-01000
19	6021-U1-1073	X	GRAISSE (400G)	LI12 HYDROXYSTEARAT
20	741-1134	1	BILLE	FINISH:SIEHE ZG.
21	761-0202	1	DISQUE DE FREIN	FINISH:ÖL UND FETTFREI
32	716-0231	1	CIRCLIPS	FINISH:SPEC-100016
33	716-0385	1	CIRCLIPS	SHR-39:FINISH PHOS & OIL
36	732-0614	1	CIRCLIPS	FINISH:ZINC PHOSPHATE
37	736-0336	1	RONDELLE 5/8X1.00X.030	FINISH:MTD SPEC-100016
38	736-0337	2	RONDELLE 5/8 IDX1.0 ODx.040	MTD STD 701-01001 936-0337
39	736-0349	1	RONDELLE 5/8 IDX10 OD K.020	FINISH:SIEHE ZG.
40	736-04337	1	RONDELLE	FINISH:GEÖLT
41	736-0494	1	RONDELLE	FINISH:MTD SPEC-100016
42	736-0495	1	RONDELLE	FINISH:SIEHE ZG. 936-0495
43	741-0524A	3	ROULEMENT	FINISH:SIEHE CHART *
52	717-04537	2	PIGNON 55 DENTS	FINISH:ÖL GEDIPPT
53	718-04045	1	PIGNON BALADEUR	FINISH:SIEHE ZG.
61	741-04458	1	BAGUE	FINISH:ÖL-IMPRÄGNIERT
63	092.60.138	1	SERVICE KIT LT-5 BOÏTE	E-TEIL-SET

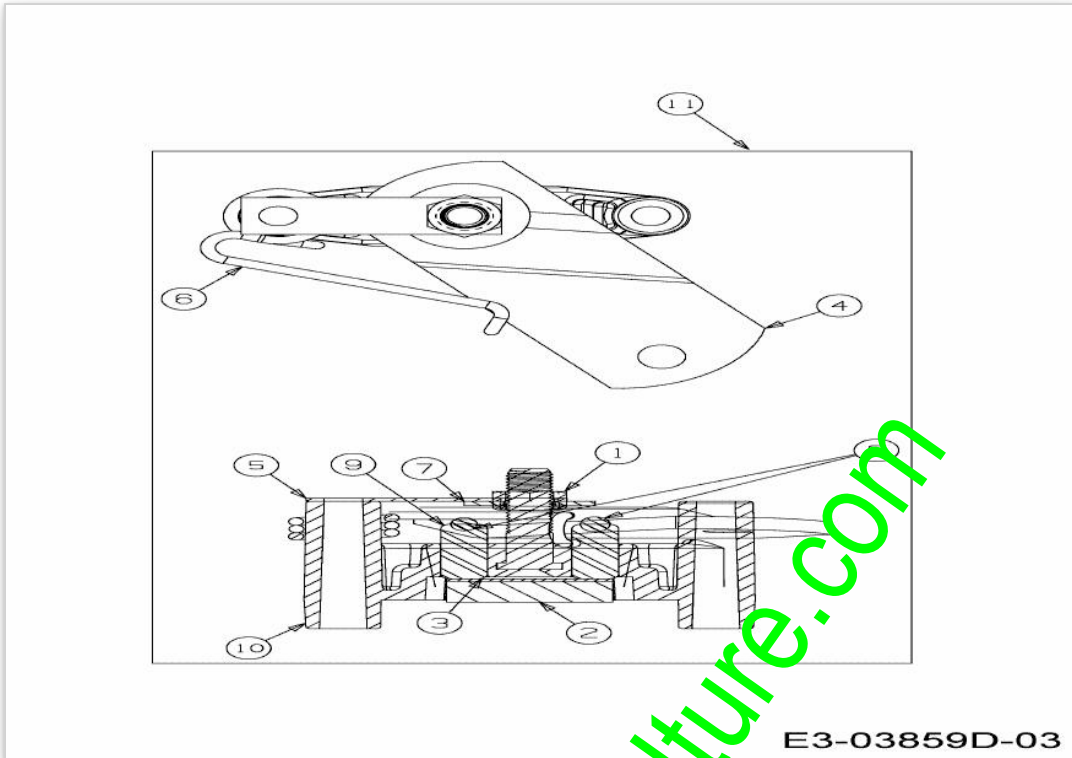

E3-03859D-03

www.emc-motoculture.com

Position	Numéro de pièce	#	Appellation I	Appellation II
1	712-0273	1	ECROU HEXAGONAL 5/16-24"	FINISH:MTD SPEC-100015
2	717-0678	1	PLAQUETTE DE FREIN	FINISH:
3	717-0682	1	INSERT DE FREIN	FINISH:NONE 917-0682
4	717-0700	1	LEVIER DE FREIN, j DROITE	FINISH:PHOSPHATE & OIL
5	718-0150	1	LANG. DE SUPP.: ANTI ROTATION	FINISH:SPEC-100015
6	732-0743	1	RESSORT	FINISH:ZINC PHOS&OIL 932-0743
7	736-0371	1	RONDELLE 1.344XA .875"	FINISH:MTD SPEC-100016
9	741-0343	2	GOIJON DE PRESSION 5/16"	FINISH:SEHE ZG. 941-0343
10	761-0198A	1	APPUI DE FREIN	FINISH:NONE 961-0198A
11	661-0006	1	SUPPORT PLAQUETTE FREIN	FINISH:

www.emc-motoculture.com

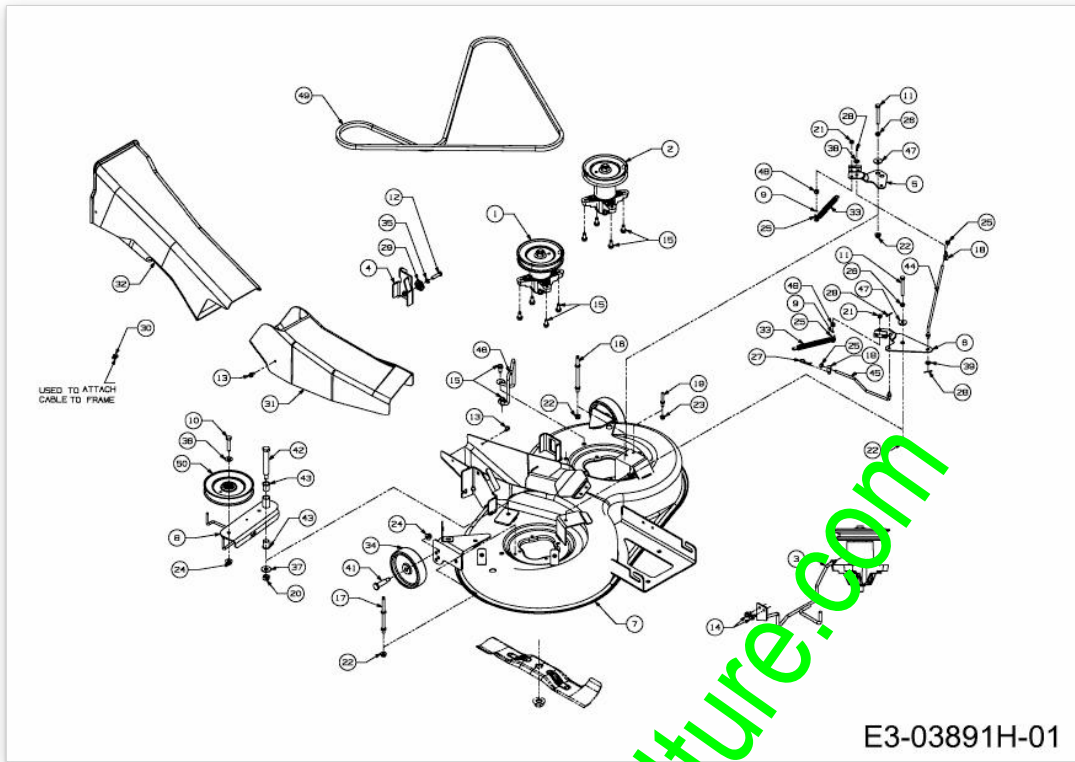

www.emc-motoculture.com

E3-03891H-01

Position	Numéro de lapièce	#	Appellation I	Appellation II
1	918-0324D	1	PALIER DE LAME CPL.D :	RIEMENSCHLEIBE 5.75 DIA
2	618-0409C	1	PALIER DE LAME COMPLET	
3	647-04144	1	TRINGLE GUIDE COURROIE	SCHWEISSTEIL:BLANK *
4	683-04396	1	SUPPORT PLATEAU	SCHWEISSTEIL:LACKIERT LT-5
5	683-04409	1	BREMSE VOLLST:DECK:A/C/N- DECK	LT5: NIETTEIL
6	683-04417	1	FREIN DE LAME	LT5: NIETTEIL
7	683-04418A	1		
8	683-04420	1	SPANNROLLENTÄGER VOLLST.	SCHWEISSTEIL:FINISH:LACKIERT
9	710-0106	2	VIS HEX. 1/4-20:1.25:GR5:SPEC	FINISH:MTD SPEC-100015
10	710-0347	1	VIS HEX. 3/8-16:1.75:GR5:STD	FINISH:MTD SPEC-100015
11	710-0378	2	VIS HEX.:5/16-18:2.50:GR5:STD	FINISH:MTD SPEC-100015
12	710-0528	1	VIS HEX. 5/16-18:1.25:GR5:STD	FINISH:SPEC-100015 910-0528
13	710-0599	2	VIS A SIX PANS CREUX	FINISH:MTD SPEC-101617
14	710-0607	2	VIS HEX.TT5/16-18:.500HXINDWSh	FINISH:MTD SPEC-100016 TYPE 1
15	710-1260A	10	VIS TT:5/16-18:.750	FINISH:SPEC-100016 TYPE 1
16	711-05319	1	GUIDE COURROIE	SCHWEISSTEIL:FINISH:PHOS & OIL
17	711-05320	1	GUIDE COURROIE	SCHWEISSTEIL:FINISH:PHOS & OIL
18	711-0736	2	AXE	FINISH:MTD SPEC-100015
19	711-0993	1	GUIDE COURROIE	FINISH:701-01006 911-0993
20	712-0290	1	ECROU 7/16-14	FINISH:MTD SPEC-100015
21	712-0291	2	ECROU EX AF-43013	FINISH:ASTM F1941 FE/ZN 3AN
22	712-04063	4	ECROU HEX. AVEC FLANC	FINISH:MTD SPEC-100015
23	712-04064	1	ECROU HEXAGONAL	FINISH:SPEC-100015 912-04064
24	712-04065	3	ECROU HEXAGONAL	FINISH:SPEC-100015 912-04065
25	712-3006	4	ECROU HEXAGONAL	FINISH:SPEC-100015
26	712-3007	2	ECROU HEX 5/16-18 GR5	FINISH:MTD SPEC-100015
27	714-0145	1	GOUPILLE	FINISH:SPEC-701-01006
28	714-0507	3	GOUPILLE FENDUE 3/32 X .750	FINISH:MTD SPEC-100015
29	717-04074	1	PIGNON HAUTEUR PLATEAU	PHOS & SPEC-100015 917-04074
30	729-04033	1	CLIPS SERRE CABLE	729-04033
31	731-06251	1	CANAL D'EJECTION INFERIEUR	FINISH:SCHWARZ
32	731-06252	1	CANAL D'EJECTION SUPERIEUR	FINISH:SCHWARZ
33	732-0604A	2	RESSORT	FINISH:PHOS AND OIL
34	734-0973	2	ROULETTE DE PLATEAU	FINISH:KUNSTSTOFF SCHWARZ
35	736-0119	1	RONDELLE	FINISH:MTD SPEC-100016
36	736-0300	1	RONDELLE	FINISH:MTD SPEC-100015
37	736-04097A	1	RONDELLE:PLATE:11.65x28.75x3mm	FINISH:MTD SPEC-100015
38	736-0700	1	RONDELLE A8.4 DIN 125	MTD SPEC-100015 24.6481.18
39	736-3020	1	RONDELLE	FINISH:MTD SPEC-100015
41	738-0373	2	VIS A EPAULE .496x1.525:3/8-16	FINISH:MTD SPEC-100015

Position	Numéro de lapièce	#	Appellation I	Appellation II
42	738-0476	1	VIS A EPAULE .625x3.50:7/16-14	FINISH:SPEC-100015
43	741-0591	2	BAGUE	FINISH:NATUR 941-0591
44	747-04781	1	TIGE DE FREIN	FINISH:SPEC-100015
45	747-04782B	1	TIGE DE FREIN	FINISH:SPEC-100015
46	747-04840	1	GUIDE COURROIE	FINISH:SPEC-100015
47	748-0234	2	RONDELLE EPAULEE	FINISH:ROSTPREVENTION
48	750-05381	2	ENTRETOISE	FINISH:IN ÖL SAE 30 GEDIPPT
49	754-04175	1	COURROIE DE COUPE 92 CM	FINISH:
50	756-04050	1	POULIE DE COURR. TR. Ø 6.0"DIA	KUGELGELAGERT: SCHWARZ LACKIERT

www.emc-motoculture.com

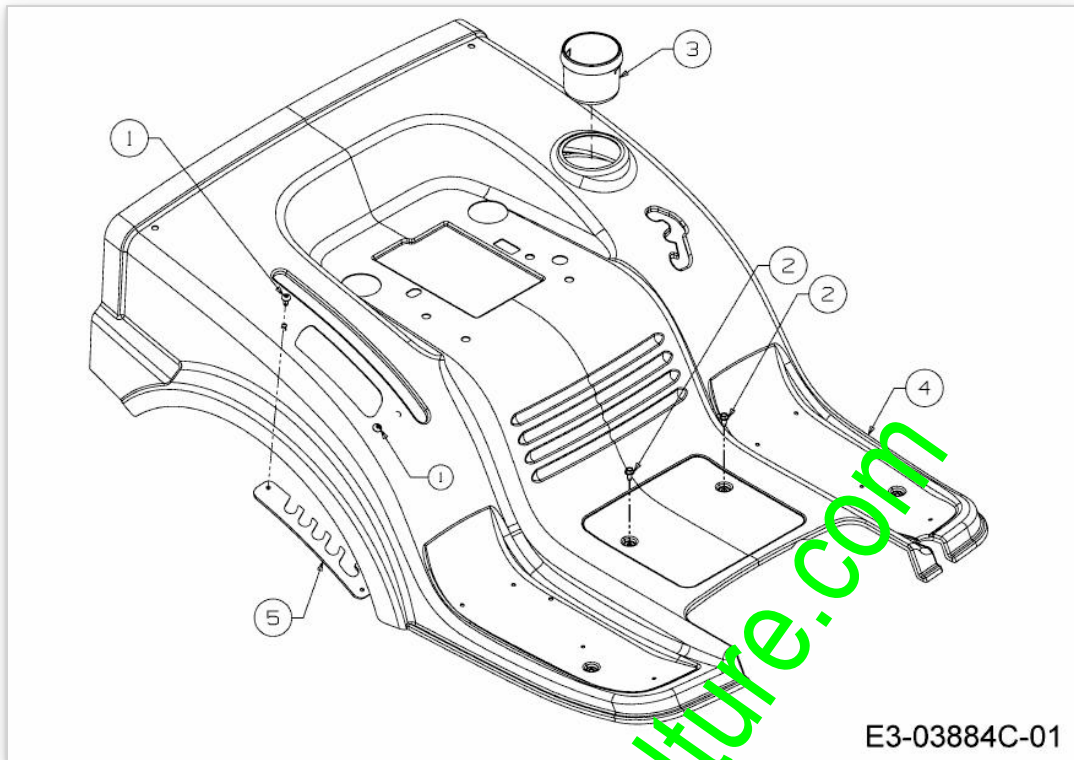

E3-03884C-01

www.emc-motoculture.com

Position	Numéro de lapièce	#	Appellation I	Appellation II
1	710-05070	2	VIS	FINISH: SCHWARZ SPEC 701-01010
2	710-0599	2	VIS A SIX PANS CREUX	FINISH: MTD SPEC-101617
3	731-04591A	1	PORTE GOBELET	FINISH: KUNSTSTOFF SCHWARZ
4	783-05744691	1	JUPE NOIRE	BLACK JACK
5	783-05875A	1	SELECTEUR HAUTEUR DE COUPE	FINISH: 783-05875A-Z 5 POS

www.emc-motoculture.com

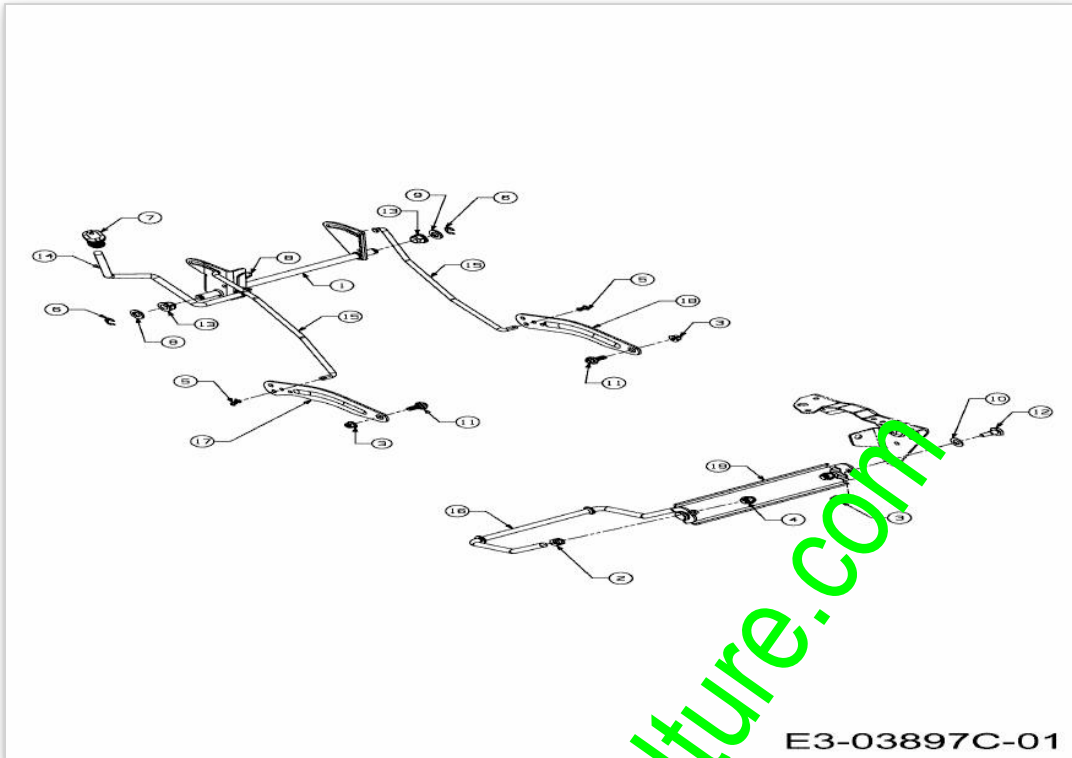

www.emc-motoculture.com

E3-03897C-01

Position	Numéro de pièce	#	Appellation I	Appellation II
1	683-04466637	1	AXE DE RELEVAGE	SCHWEISSTEIL:FINISH LACKIERT
2	712-0206	2	ECROU HEX. 1/2-13:GR.5	FINISH:MTD SPEC-100015
3	712-04065	4	ECROU HEXAGONAL	FINISH:SPEC-100015 912-04065
4	712-3083	2	ECROU HEX. 1/2-13:GRB:NYLON	FINISH:MTD SPEC-100015
5	714-04040	2	GOUPILLE	FINISH:ASTM F1941 FE/ZN 3AN
6	716-0106A	2	CIRCLIPS	FINISH:PHOSPHATIERT
7	720-0311	1	POIGNÉE LEVIER COUPE : 1/2	FARBE: SCHWARZ VINYL
8	732-04225	1	RESSORT	FINISH:MTD STD 701-01006
9	736-0366	2	RONDELLE 5/8 ID X 1.0 OD	FINISH:MTD SPEC-100015
10	736-0414	2	RONDELLE TÛFLON	FINISH:WEISS: 936-0414
11	738-04130	2	VIS .625X.175:3/8-16	FINISH:701-01002
12	738-0507B	2	VIS	FINISH:MTD SPEC-701-01006
13	741-0225	2	BAGUE HEXAGONALE TEFLON 6 PANS	FINISH:KUNSTSTOFF SCHWARZ
14	747-04282	1	LEVIER DE RELEVAGE LT-5	FINISH:SPEC-100015
15	747-04842	2	TRINGLE DE RELEVAGE	A/C/E/N-Deck:747-04842-Z
16	747-1324	1	TRINGLE	FINISH:SPEC-100015
17	783-04494C-S	1	LEVIER DE RELEVAGE DROITE	SCHWARZ
18	783-04711C-S	1	BRAS DE RELEVAGE GAUCHE	SCHWARZ
19	783-0720C637	1	SUPPORT DE RELEVAGE	SCHWARZ

www.enj-motoculture.com

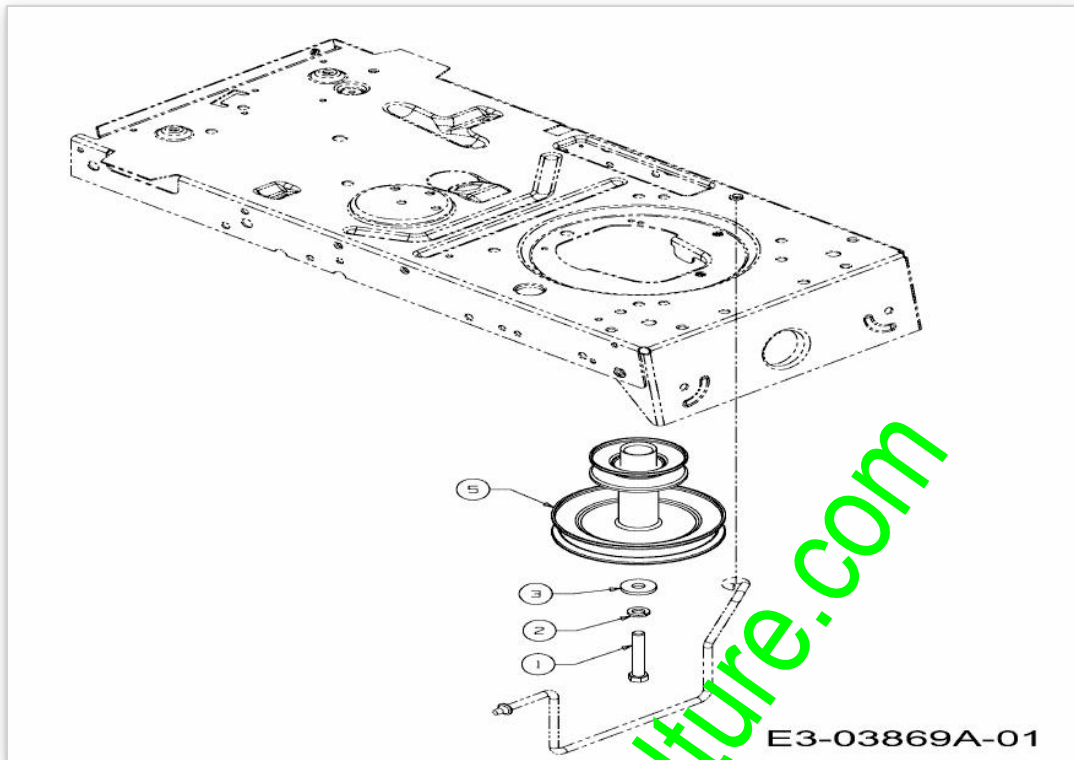

www.emc-motoculture.com

Position	Numéro de pièce	#	Appellation I	Appellation II
1	710-04607	1	VIS POULIE MOTEUR	FINISH:MTD SPEC-100015
2	736-0171	1	RONDELLE GROWER	FINISH:MTD SPEC-100016
3	736-0322	1	RONDELLE .450 X 1.250 X .164	FINISH:SPEC-100016 936-0322
5	756-04310	1	POULIE MOTEUR	GETRIEBE:FINISH:SPEC-100015

www.emc-motoculture.com

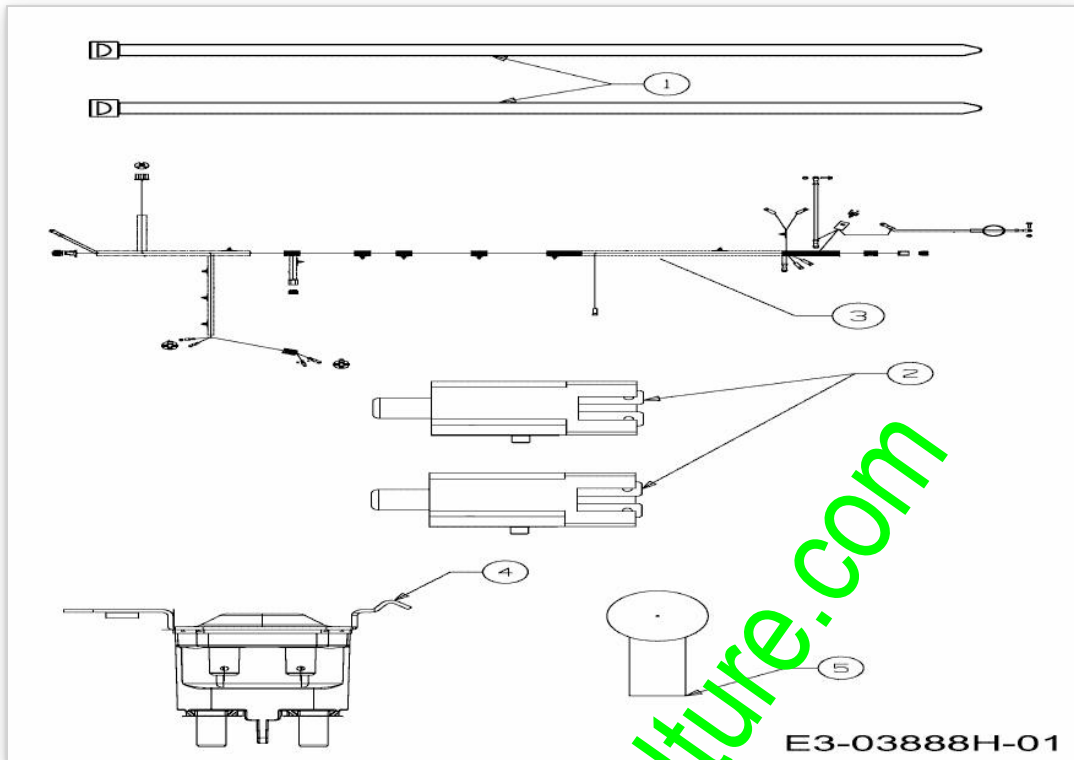

E3-03888H-01

Position	Numéro de pièce	#	Appellation I	Appellation II
1	725-0157	2	COLLIER DE SERRAGE3/16X0.5X7.4	MATERIAL:NYLON-SCHWARZ
2	725-04363	2	SECURITE EMBRAYAGE	FINISH:SIEHE ZG.
3	725-05502	1	FAISCEAU ELECTRIQUE	RR BAG
4	725-06153	1	SOLENOIDE	FINISH:
5	725-3237	1	COUVERCLE POLE / ROUGE	BATTERIE FINISH:ROT

www.emc-motoculture.com

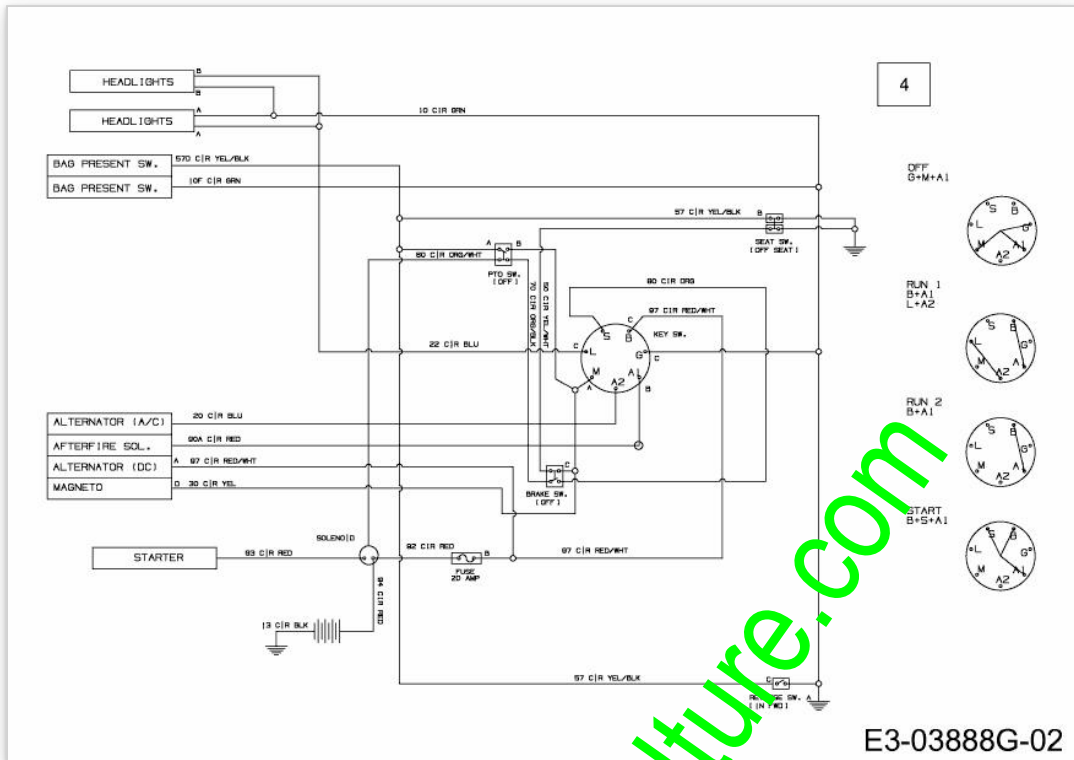

www.emc-motoculture.com

Position	Numéro de lapièce	#	Appellation I	Appellation II
4	725-05502	1	FAISCEAU ELECTRIQUE	RR BAG

www.emc-motoculture.com

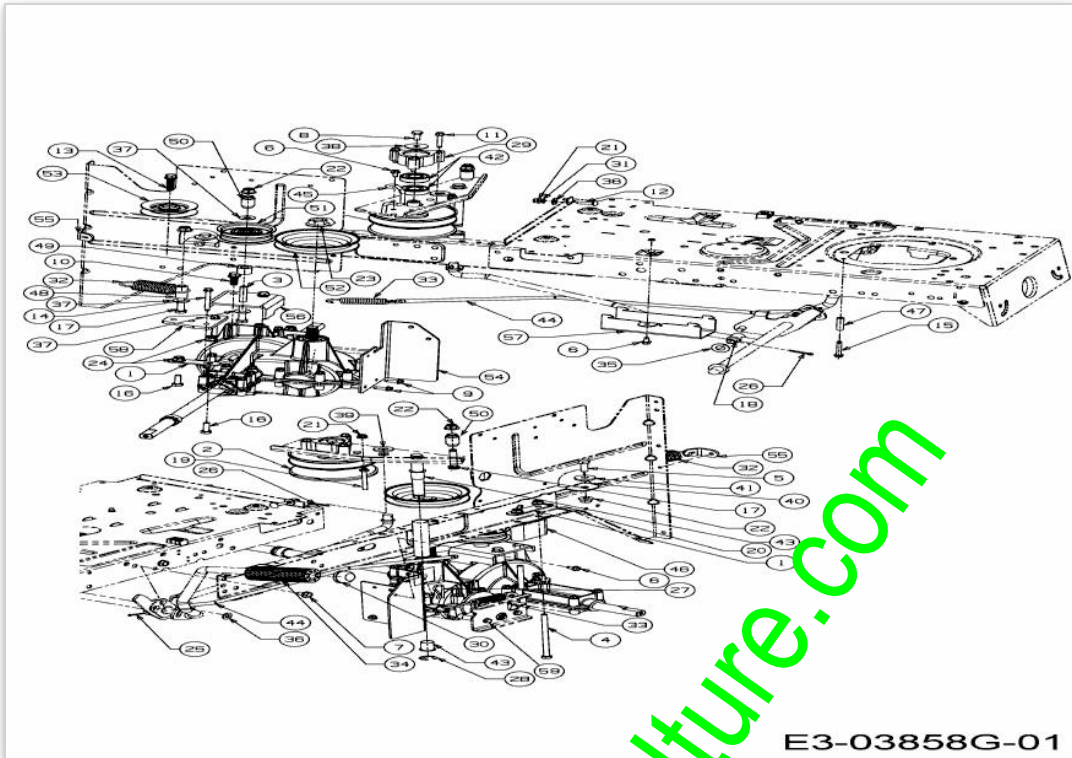

www.emc-motoculture.com

Position	Numéro de pièce	#	Appellation I	Appellation II
1	17840	2	SUPPORT	FINISH: 17840-Z
2	656-04015A	1	POULIE VARIATEUR	FINISH:
3	710-0411	1	VIS HHCS:3/8-16:4.00:GR5:STD	FINISH:SPEC-100015
4	710-04469	2	VIS HEX. 5/16-18X5.00:GR5:STD	FINISH:MTD SPEC-100015
5	710-0514	1	VIS HEX.:3/8-16:1.00:GR5:STD	FINISH:MTD SPEC-100015
6	710-0599	4	VIS A SIX PANS CREUX	FINISH:MTD SPEC-101617
7	710-0604A	2	VIS 5/16-18:0.625	FINISH:MTD SPEC-100016 TYPE 1
8	710-0627	1	VIS HEX. 5/16-24:.750 GR5:LOCK	FINISH:MTD SPEC-100015
9	710-0642	2	VIS1/4-20:0.750	SPEC-100016 TYPE 1 910-0642
10	710-0654A	2	VIS A SIX PANS CREUX	FINISH:GEOMET XL
11	710-0778	3	VIS HEX. TT:1/4-20:1.500	FINISH:MTD SPEC-100016 TYPE 1
12	710-0932A	1	VIS	FINISH:MTD SPEC-100015
13	710-1007	1	VIS HEX.TTSEMS3/8-16:1,500	FINISH:STD SPEC-100016
14	710-1206	2	VIS HEX. TT:1/4-20:2.375	FINISH:MTD SPEC-100016 TYPE 1
15	710-1325	1	VIS HEXAGONALE	FINISH:SPEC-100016 TYPE 1
16	710-1682	2	VIS	FINISH:SPEC-100015 21.1441.72
17	710-3144	2	VIS HEX.: 3/8-16:2.00:GR5:STD	FINISH:SPEC-100015 910-3144
18	711-04036	1	AXE	FINISH:SPEC-100015 911-04036
19	711-04826	1	GUIDE COURROIE	BLACK OXIDE ODER PHOS & OIL
20	712-04063	2	ECROU HEX. AVEC FLANC	FINISH:MTD SPEC-100015
21	712-04064	2	ECROU HEXAGONAL	FINISH:SPEC-100015 912-04064
22	712-04065	4	ECROU HEXAGONAL	FINISH:SPEC-100015 912-04065
23	712-0700	1	ECROU HEXAGONAL	SPEC-100015+WAX 912-0700
24	712-0714	2	ECROU	FINISH:MTD SPEC-100015
25	714-0111	1	GOUPILLE FENDUE 3/32:1.0"	FINISH:MTD SPEC-100015
26	714-0115	2	GOUPILLE FENDUE 1/8 x 1.0	FINISH:MTD SPEC-100015
27	714-0209	1	GOUPILLE FENDUE	FINISH:SPEC 701-01006 914-0209
28	716-0106A	1	CIRCLIPS	FINISH:PHOSPHATIERT
29	718-04261	1	CAGE DE ROULEMENT	FINISH:ROSTSCHUTZ SIEHE ZG.
30	726-0214	1	BOUCHON	FINISH:SCHWARZ

Position	Numéro de pièce	#	Appellation I	Appellation II
31	726-0233	1	RONDELLE	MECHANISCH KLAR VERZINKT
32	732-04505	1	RESSORT 1.00 DIA X 3.925 LG	FINISH:PHOS AND OIL
33	732-0716D	1	RESSORT	FINISH:MTD STD 701-01006
34	735-0239	1	CAOUTCHOUC/PEDALE 4;0 LG	FINISH:SCHWARZ
35	736-0272	1	RONDELLE .510x1.00X.060	SPEC 100015 oder SPEC-101616
36	736-0275	2	RONDELLE	FINISH:MTD SPEC-100015
37	736-0300	3	RONDELLE	FINISH:MTD SPEC-100015
38	736-0362	1	RONDELLE .320ID X 1.25 ODX .0	FINISH:SPEC-100016
39	736-3019	1	RONDELLE .531x1.062x.134:HT	FINISH:MTD SPEC-100016
41	738-0347	1	RONDELLE j EMB. .625IDx.169	FINISH:
42	741-0124A	2	ROULEMENT A BILLE	FINISH:
43	741-0591	2	BAGUE	FINISH:NATUR 941-0591
44	747-04815C	1	TIGE DE FREIN	FINISH:SPEC-100015
45	747-04897D	1	GUIDE COURROIE	FINISH: 747-04897D-Z
46	748-04175	1	SUPPORT ENTRETOISE	FINISH:GEÖLT
47	750-04456	1	ENTRETOISE	FINISH:MTD SPEC-100015
48	750-04584	1	DOUILLE .375IDx.625ODx 1.34 LG	FINISH:SPEC-100015
49	750-04988	1	ENTRETOISE	FINISH:ÖL GEDIPPT
50	750-05521A	2	LAGERBUCHSE:18mm ODx9.8mm ID	FINISH:GEÖLT
51	756-04224	1	POULIE TENDEUR	BLK ECOAT,PAINT OR SPEC-100015
52	756-04298	1	POULIE DE PONT	PINS:FINISH:SIEHE ZG.656-04044
53	756-04324	1	POULIE TENDEUR	FINISH:SCHWARZ LACKIERT
54	783-05705637	1	SUPPORT DE PONT	FINISH:LACKIERT
55	783-05844-Z	1	EQUERE	FINISH:SPEC-101642
56	783-05855637	1	SUPPORT	SCHWARZ
57	783-05882637	1	SUPPORT	FINISH:LACKIERT
58	783-1363	1	PLAQUE SUPPORT	FINISH:BLAU CHROMATIEREN *
59	710-1206	2	VIS HEX. TT:1/4-20:2.375	FINISH:MTD SPEC-100016 TYPE 1

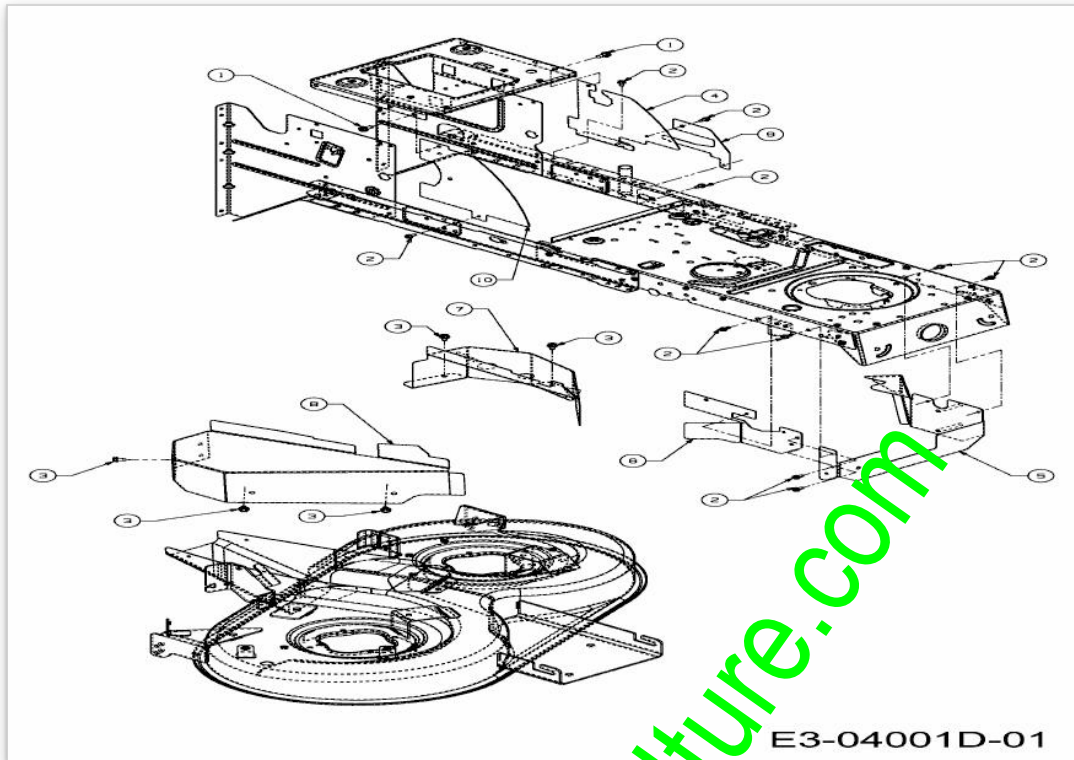

www.emc-motoculture.com

Position	Numéro de lapièce	#	Appellation I	Appellation II
1	710-04484	2	VIS HEX. TT:5/16-18.:.750:HXIND	FINISH:MTD SPEC-100016 TYPE 1
2	710-0599	10	VIS A SIX PANS CREUX	FINISH:MTD SPEC-101617
3	710-0607	5	VIS HEX.TT5/16-18.:.500HXINDWSh	FINISH:MTD SPEC-100016 TYPE 1
4	783-05994	1	ABDECKUNG RE.HINTEN:LT-5	FINISH:LACKIERT MTD QUALITÄT
5	783-05998	1	ABDECKUNG1 FRANCE:LT-5:E-DECK	FINISH:LACKIERT MTD QUALITÄT
6	783-05999	1	ABDECKUNG2 FRANCE:LT-5:E-DECK	FINISH:LACKIERT MTD QUALITÄT
7	783-06000	1	ABDECKUNG3 FRANCE:LT-5:E-DECK	FINISH:LACKIERT MTD QUALITÄT
8	783-06001A	1	FINISH:LACKIERT MTD QUALITÄT	FINISH:LACKIERT MTD QUALITÄT
9	783-06084	1	ABDECKUNG2:GETRIEBE:AUTO:LINKS	FINISH:LACKIERT MTD QUALITÄT
10	783-06676	1	PROTECTION DROITE	FINISH:LACKIERT MTD QUALITÄT

www.emc-motoculture.com

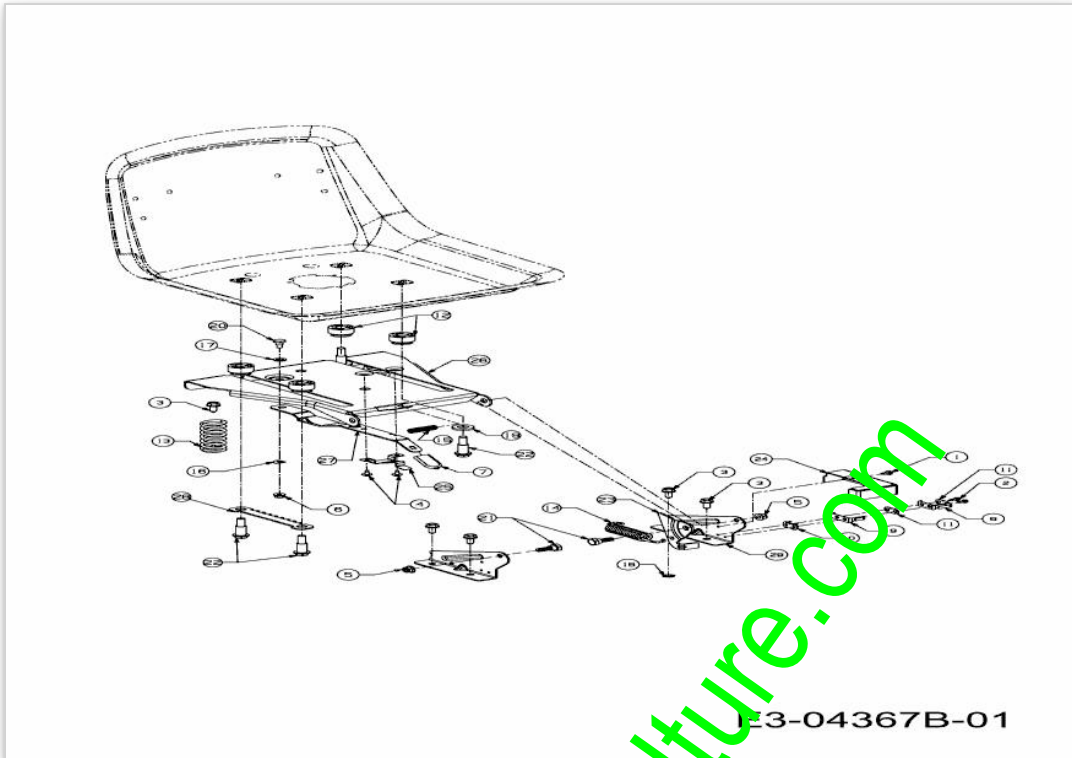

www.emc-motoculture.com

Position	Numéro de lapièce	#	Appellation I	Appellation II
1	710-0224	1	VIS PARK:#10- 16:0.500:HXINDWSH	FINISH:MTD SPEC-100016 TYPE 1
2	710-0227	2	VIS	FINISH:MTD SPEC-100016 TYPE 1
3	710-04484	6	VIS HEX. TT:5/16- 18:.750:HXIND	FINISH:MTD SPEC-100016 TYPE 1
4	710-1268	2	VIS HEX.:B#10-16:0.375	HXINDWSH:SP FINISH:701-01002
5	712-04063	2	ECROU HEX. AVEC FLANC	FINISH:MTD SPEC-100015
6	712-04064	1	ECROU HEXAGONAL	FINISH:SPEC-100015 912-04064
7	720-0309A	1	POIGNÛE PLASTIQUE	FINISH:SCHWARZ
8	725-1303	1	RESSORT DE SURETE SIËGE	SI.-SCHALTER SITZ:SPEC-100015
9	725-1439	1	RESSORT SURETE DE SIEGE	SI.-SCHALTER SITZ:SPEC-100015
10	726-0278	1	PLAQUE D'ISOLATION	FINISH:NATUR ODER SCHWARZ
11	726-0279	2	PLAQUE D'ISOLATION	FINISH:NATUR ODER SCHWARZ
12	731-04074	4	ENTRETOISE PLASTIQUE DE SIEGE	FINISH:SCHWARZ
13	732-04035	2	RESSORT DE SIEGE	FINISH:SPEC-100015
14	732-04309	1	RESSORT	FINISH:MTD STD 701-01006
15	732-0499	1	RESSORT	FINISH:SPEC-100015
16	736-0175	1	RONDELLE GROWER:.265x.562x.025	FINISH:701-01001
17	736-0204	1	RONDELLE .344 X 62 X.03	FINISH:MTD SPEC-100015
18	736-0607	1	RONDELLE	FINISH:MTD SPEC-100016
19	736-3019	2	RONDELLE .531x1.062x.134:HT	FINISH:MTD SPEC-100016
20	738-0137A	1	VIS A EPAULE .340 X .285:1/4-2	FINISH:GM4435M CODE A
21	738-0296	2	AXE EPAULE	FINISH:SPEC-100015
22	738-0966A	1	VIS EPAULEE	FINISH:MTD SPEC 701-01006
23	783-0209D	1	SUPP. SIËGE	FINISH:SPEC-100016
24	783-04877A	1	783-06279	FINISH:LACKIERT
25	783-0611	1	ARRET AJUSTAGE DE SIEGE	FINISH:PHOS & OIL
26	783-0738D	1	SUPPORT DE SIËGE	FINISH:LACKIERT
27	783-0739A	1	LEVIER DE RÜGLAGE	FINISH:LACKIERT
28	783-0753	1	CREMAILLERE REGLAGE SIEGE	FINISH:SPEC-100015
29	783-1489D	2	783-1489B-4015 / FEUERROTQ	

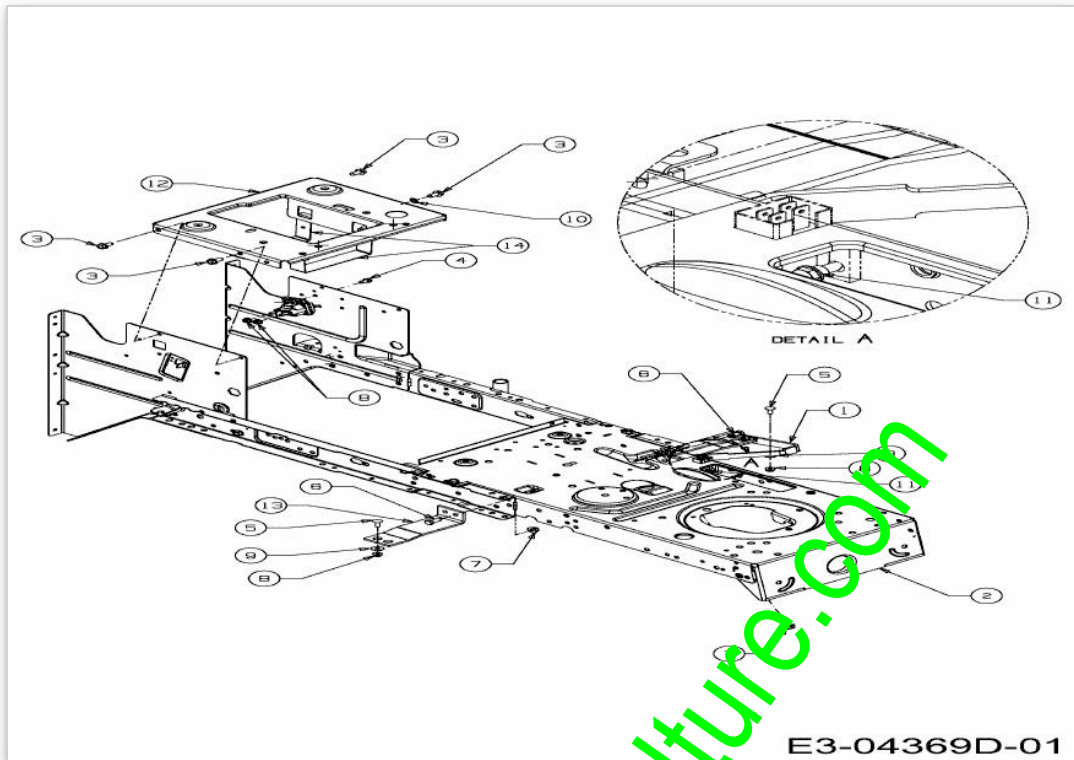

Position	Numéro de pièce	#	Appellation I	Appellation II
1	683-04195637	1	SUPPORT	SCHWEIßTEIL / SCHWARZ LACKIERT
2	683-04682B-S	1	RAHMEN VOLLST:LT-5:TRANSMATIC	SCHWARZ LACKIERT
3	710-04484	4	VIS HEX. TT:5/16-18:.750:HXIND	FINISH:MTD SPEC-100016 TYPE 1
4	710-0599	1	VIS A SIX PANS CREUX	FINISH:MTD SPEC-101617
5	710-0703	2	VIS	FINISH:MTD SPEC-100015
6	710-3008	2	VIS 5/16-18:.75:GR5:STD	SPEC-701-01006 or.SPEC-100015
7	712-04063	3	ECROU HEX. AVEC FLANC	FINISH:MTD SPEC-100015
8	712-04064	4	ECROU HEXAGONAL	FINISH:SPEC-100015 912-04064
9	736-0173	2	RONDELLE 281DX 74ODX.063	FINISH:MTD SPEC-100015
10	736-0607	1	RONDELLE	FINISH:MTD SPEC-100016
11	738-04237A	1	AXE EPAULE	FINISH:MTD SPEC-100016
12	783-04548D-S	1	SUPPORT DE SIEGE	SCHWARZ
13	783-04637637	1	SUPPORT	SCHWARZ LACKIERT
14	783-04869A-S	2	SUPPORT BATTERIE	SCHWARZ

www.emc-motoculture.com

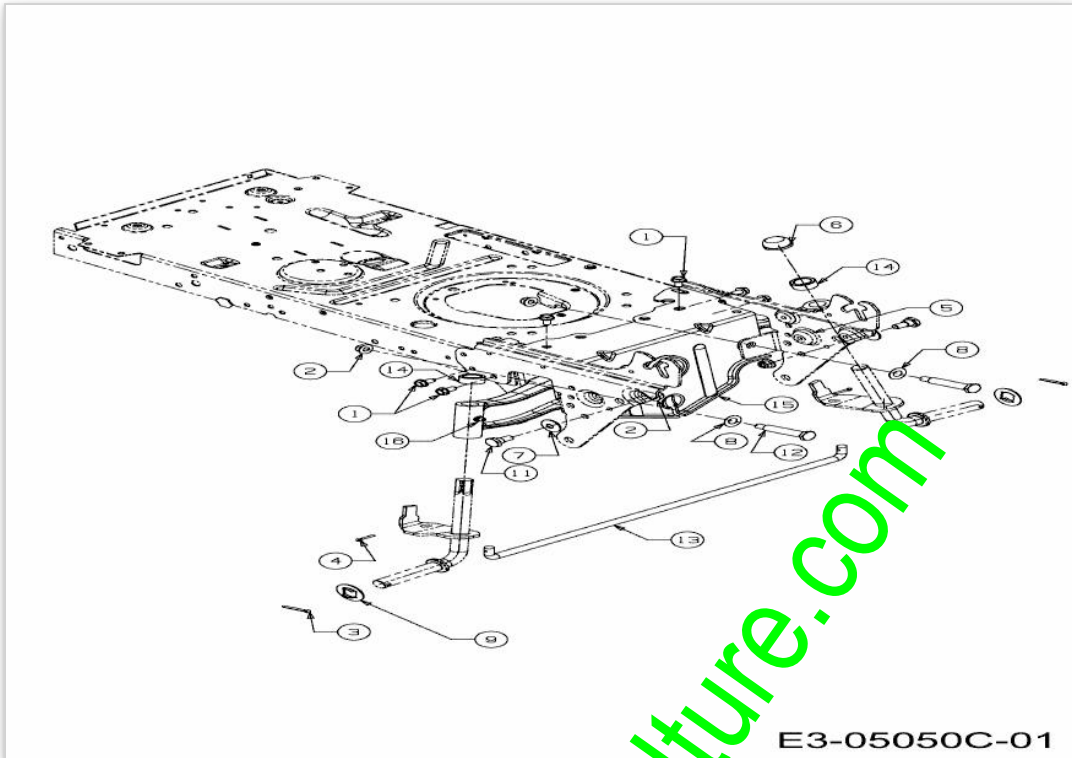

E3-05050C-01

Position	Numéro de pièce	#	Appellation I	Appellation II
1	710-04484	6	VIS HEX. TT:5/16-18:.750:HXIND	FINISH:MTD SPEC-100016 TYPE 1
2	712-04065	4	ECROU HEXAGONAL	FINISH:SPEC-100015 912-04065
3	714-0162	2	GOUPILLE FENDUE 5/32:1.25	FINISH:MTD SPEC-100015
4	714-0474	2	GOUPILLE	FINISH:MTD SPEC-100015
5	719-04177B	1		
6	726-0341	1	CAPUCHON CLIPS	FINISH:SCHWARZ
7	736-0331	2	RONDELLE CONIQUE	FINISH:MTD SPEC-100016
8	736-0369	2	RONDELLE	FINISH:SEHE ZG. 936-0369
9	736-04228A	2	RONDELLE	FINISH:MTD SPEC-100015
11	738-0143	2	VIS EPAULEE	FINISH:MTD SPEC 100015 (EU)
12	738-04128	2	VIS A EPAULE .500x2.38:3/8-16	FINISH:MTD SPEC-100015
13	747-04299A	1	TRINGLE DE DIRECTION	FINISH:SPEC-100015 or E-Coat
14	748-04068	2	DOUILLE .71IDX.125 ODX.56 LG	FINISH:SPEC-100015
15	783-05326B	1	783-05326B-S	FINISH:LACKIERT MTD QUALITÄT
16	737-3000	2	GRAISSEUR	GLEITMITTEL

www.emc-motoculture.com

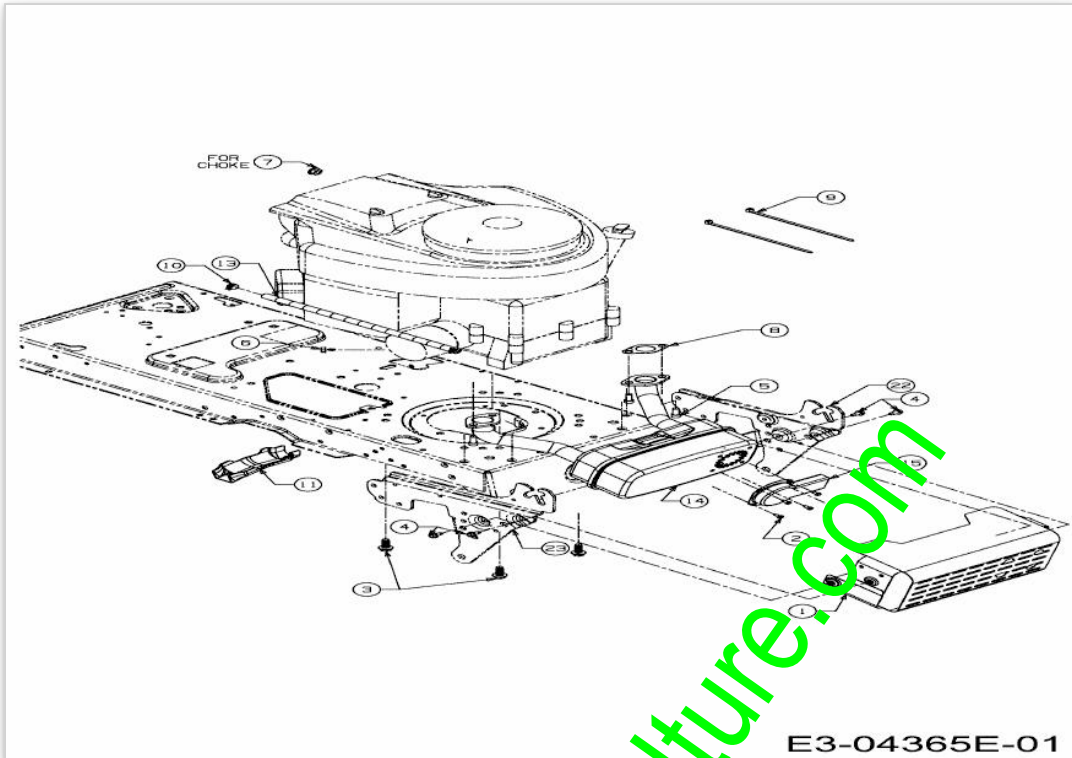

Position	Numéro de pièce	#	Appellation I	Appellation II
1	710-0227	4	VIS	FINISH:MTD SPEC-100016 TYPE 1
2	710-04683B	4	VIS	FINISH:MTD SPEC 701-01002
3	710-0599	4	VIS A SIX PANS CREUX	FINISH:MTD SPEC-101617
4	710-0604A	2	VIS 5/16-18:0.625	FINISH:MTD SPEC-100016 TYPE 1
5	710-1314A	2	VIS HEX. INT. 5/16-18:.75:GR8	FINISH: GM4435M CODE A
6	712-0271	1	ECROU 1/4-20"+ DISQUE DENTE	FINISH:MTD SPEC-100016 GR5
7	712-3005	1	ECROU AVEC FLANC:3/8-16:GR5	FINISH:SPEC 100015 912-3005
8	721-0208	1	JOINT ECHAP B/S MONO CYLINDRE	FINISH:E&S #272293
9	725-0157	1	COLLIER DE SERRAGE3/16X0.5X7.4	MATERIAL:NYLON-SCHWARZ
10	726-0205	2	COLLIER DE SERRAGE DE BOYAU	FINISH:PHOS UND GELB LACKIERT
11	731-05628	1	GOUTIERE VIDANGE D HUILE	FINISH:SCHWARZ
13	751-0535	1	TUYAU ESSENCE NOIR	Ø12,7+/-0,13 / Ø6,35+/-0,13
14	751-0564B	1	DEFLECTEUR ECHAPPEMENT	MATERIAL:ALUMINIERTER STAHL
15	751-0617B	1	POT D'ÜCHAPPEMENT	
16	751-0619B	1	PIPE D ECHAPPEMENT	MIT FLANSCH:FINISH PLAIN
17	783-0615E	1	783-0615E-RG	FINISH:LACKIERT

www.emc-motoculture.com

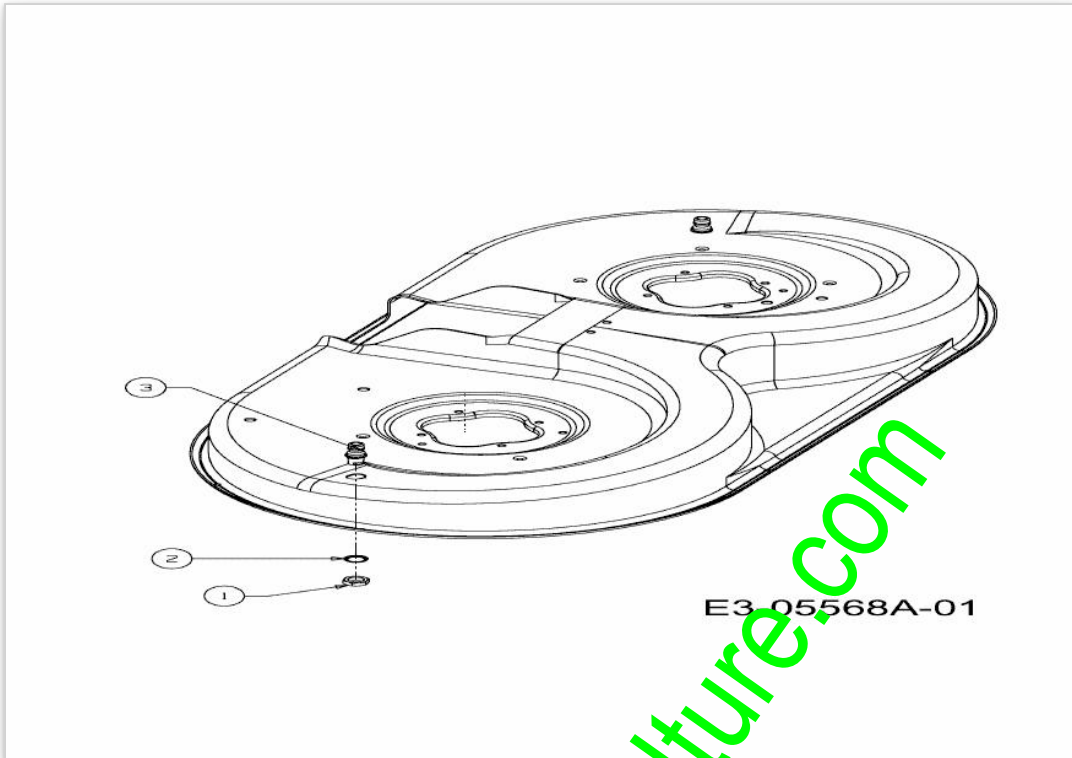

E3_05568A-01

www.emc-motoculture.com

Position	Numéro de lapièce	#	Appellation I	Appellation II
1	712-0641	2	ECROU HEX. M16-1.5 DIN 936	FINISH:SPEC-100015 24.1424.31
2	736-0760	2	RONDELLE 17X23.8X1.95	FINISH:MTD SPEC-100016
3	737-04003D	2	BUSE NETTOYAGE PLATEAU	FINISH:MTD SPEC-100015

www.emc-motoculture.com

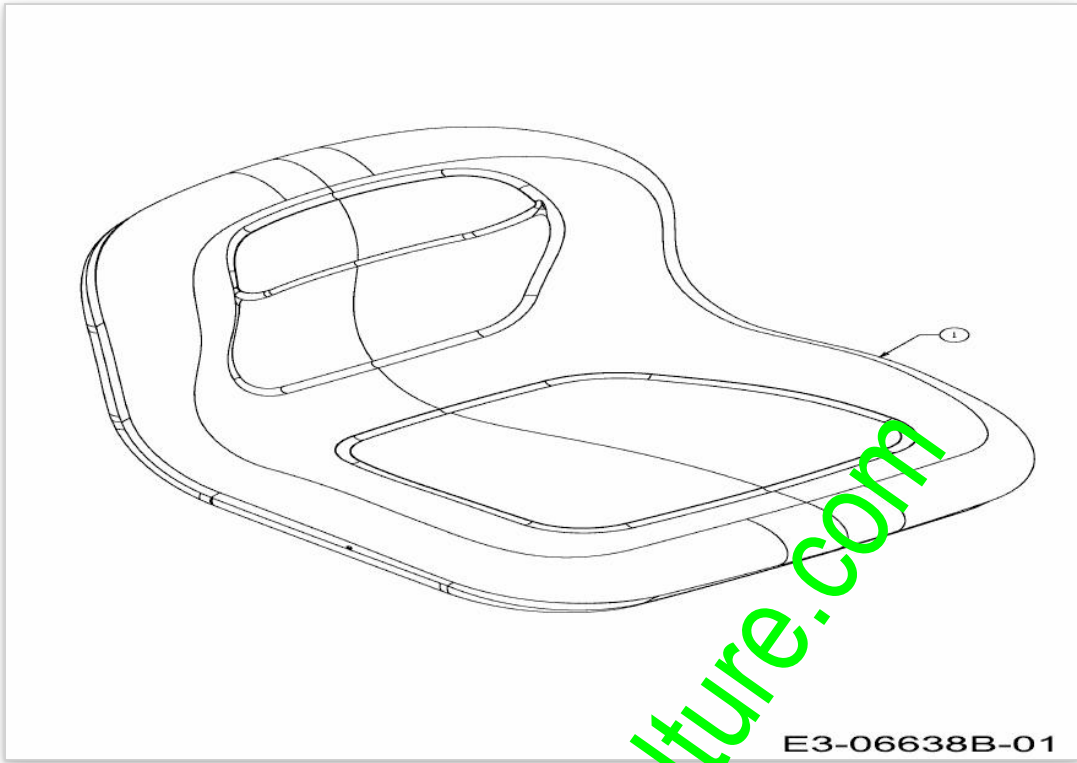

www.emc-motoculture.com

Position	Numéro de lapièce	#	Appellation I	Appellation II
1	757-04161	1	SIEGE HAUT JAUNE	757-04161

www.emc-motoculture.com

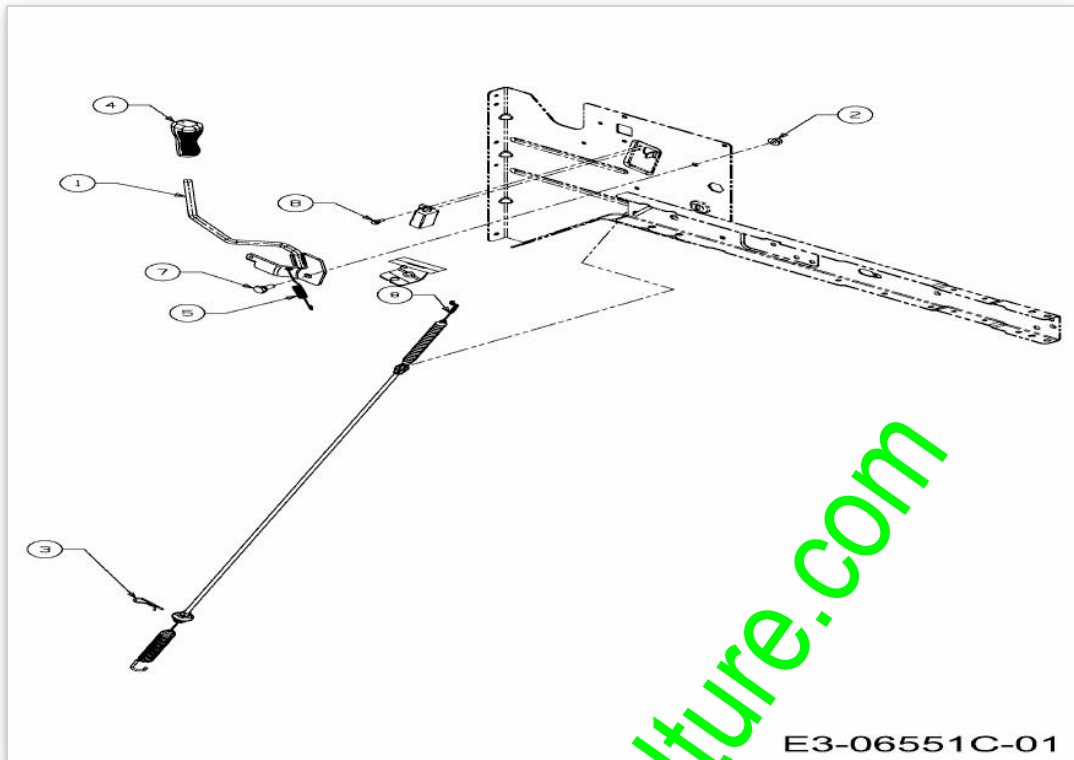

E3-06551C-01

www.emc-motoculture.com

Position	Numéro de lapièce	#	Appellation I	Appellation II
1	647-04239	1	LEVIER ENCLenchement	SCHWEISSTEIL:647-04239 SCHWARZ
2	712-04063	1	ECROU HEX. AVEC FLANC	FINISH:MTD SPEC-100015
3	714-0145	1	GOUPILLE	FINISH:SPEC-701-01006
4	720-04049A	1	POIGNEE PLASTIQUE	FINISH:SCHWARZ
5	732-04276A	1	RESSORT	FINISH:MTD SPEC-701-01006
7	738-0140	1	VIS A EP.:.435 x.178- 5/16 x.56	FINISH:MTD SPEC-100015
8	738-04237A	1	AXE EPAULE	FINISH:MTD SPEC-100016
9	746-04173E	1	CABLE D EMBRAYAGE	VERKAPSELTE TEIL-SET

www.emc-motoculture.com

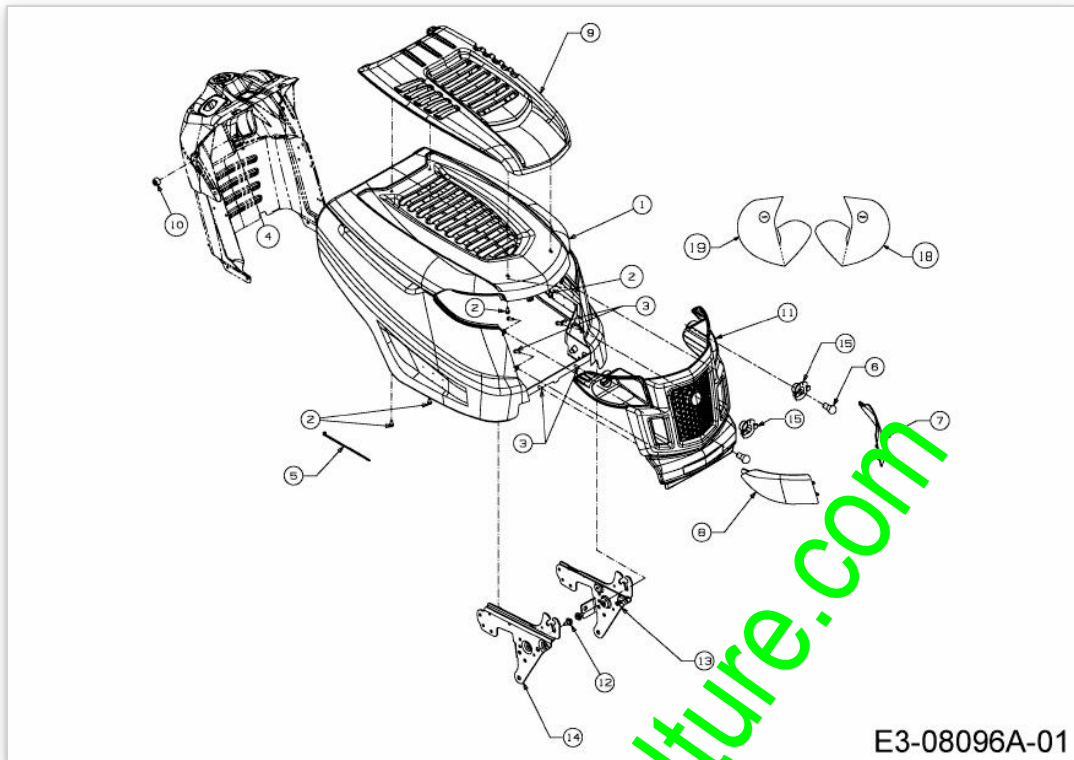

E3-08096A-01

www.emc-motoculture.com

Position	Numéro de pièce	#	Appellation I	Appellation II
1	983-04774	1	CAPOT MOTEUR INFERIEUR STYLE K	
2	710-04187	4	VIS HEX.:1/4- 15:0.50:HXINDWSH	FINISH:701-01002 910-04187
3	710-05108	6	VIS	FINISH:SPEC-701-01006
4	710-05281	2	VIS	FINISH:MTD SPEC-100016 TYPE 1
5	725-0157	1	COLLIER DE SERRAGE3/16X0.5X7.4	MATERIAL:NYLON-SCHWARZ
6	725-0963	2	AMPOULE ELECTRIQUE	FINISH:
7	731-06095	1	OPTIQUE GAUCHE	FINISH:KLAR
8	731-06096	1	OPTIQUE DROITE	FINISH:KLAR
9	731-06194B	1	CAPOT MOTEUR SUPERIEUR STYLE K	FINISH:KUNSTSTOFF SCHWARZ
10	731-06404	2	SILENBLOCK:CAPOT STYLE-K	ANMATURENBRETT:K-STYLE
11	731-06796	1	CALANDRE STYLE K	KUNSTSTOFF SCHWARZ
12	738-04091A	2	VIS EPAULEE	FINISH:SPEC-100016
13	783-05417637	1	ÉTRIER DE CHARN. À GA. CAPOT	783-05417-0637
14	783-05418637	1	ÉTRIER DE CHARN. À DR. CAPOT	783-05418-0637
15	725-1649	2	DOUILLE DE LAMPE: 1/4 ROTATION	GRAU KUNSTSTOFF
18	777X43038	1	REFLECTEUR GAUCHE	FINISH:
19	777X43039	1	REFLECTEUR DROITE	FINISH:

www.emc-motoculture.com

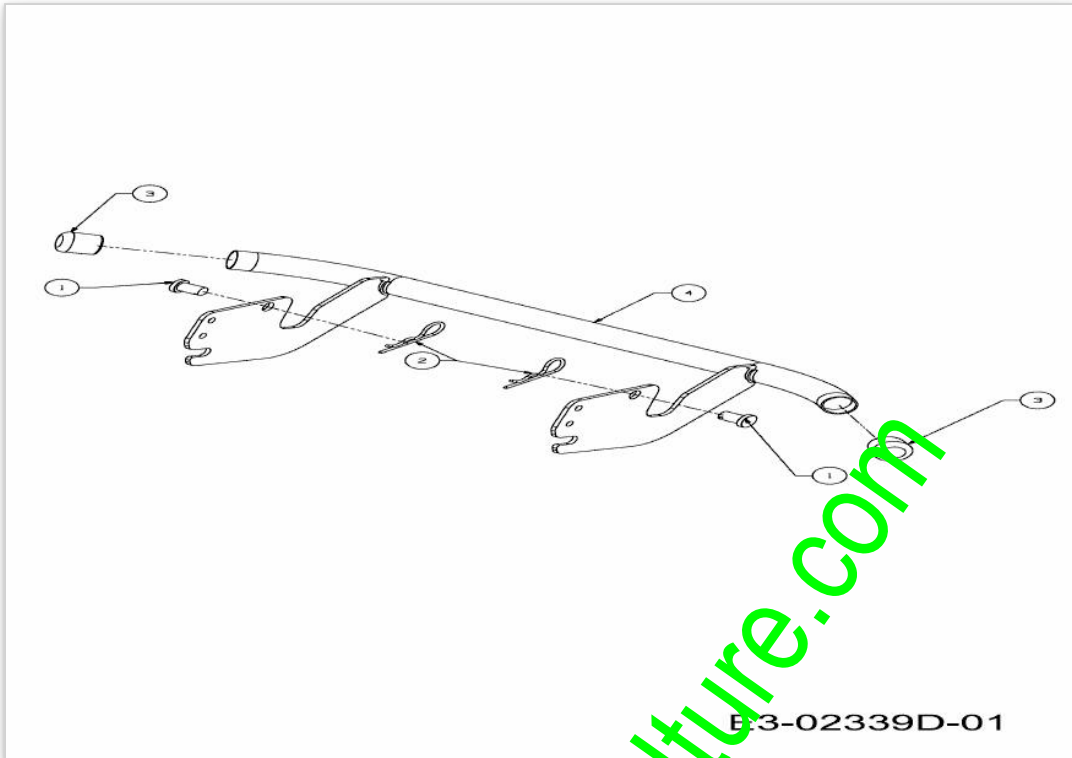

www.emc-motoculture.com

Position	Numéro de lapièce	#	Appellation I	Appellation II
1	711-0332	2	GOUJON ; ÜPINGLER .50X.78 LG	FINISH:MTD SPEC-100015
2	714-04075	2	EPINGLE	FINISH:ZINC SPEC-100015
3	731-04500	2	BOUCHON	500 SERIES:K 28 S:SCHWARZ
4	683-04236A	1	PARE-CHOCS DE FR. SÛRIE 500	SCHWEISSTEIL:FINISH LACKIERT

www.emc-motoculture.com

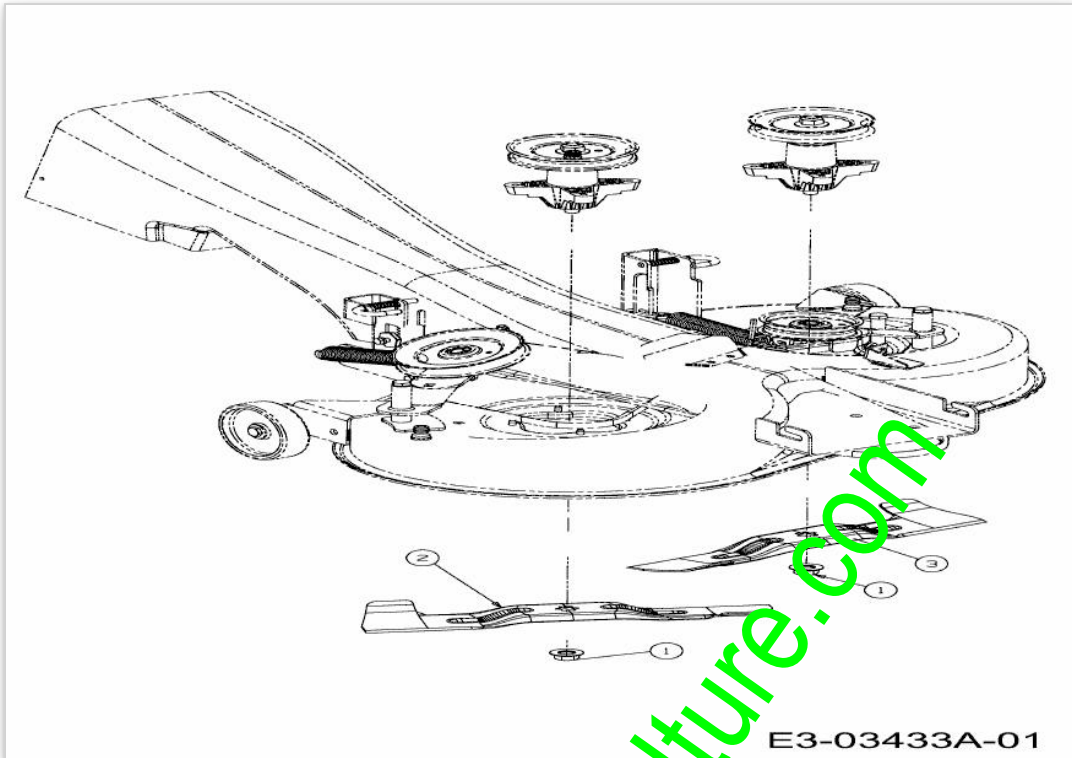

www.emc-motoculture.com

Position	Numéro de lapièce	#	Appellation I	Appellation II
1	712-0417A	2	ÜCROU HEX. AV. FLANC: 5/8-18	FINISH:MTD STD 701-01000
2	742-04020A	1	LAME j DROITE 18.40 LG	STAR BAG:WÄRMEBEHANDELT
3	742-04021A	1	LAME j GAUCHE 18.40 LG	STAR BAG:WÄRMEBEHANDELT

www.emc-motoculture.com

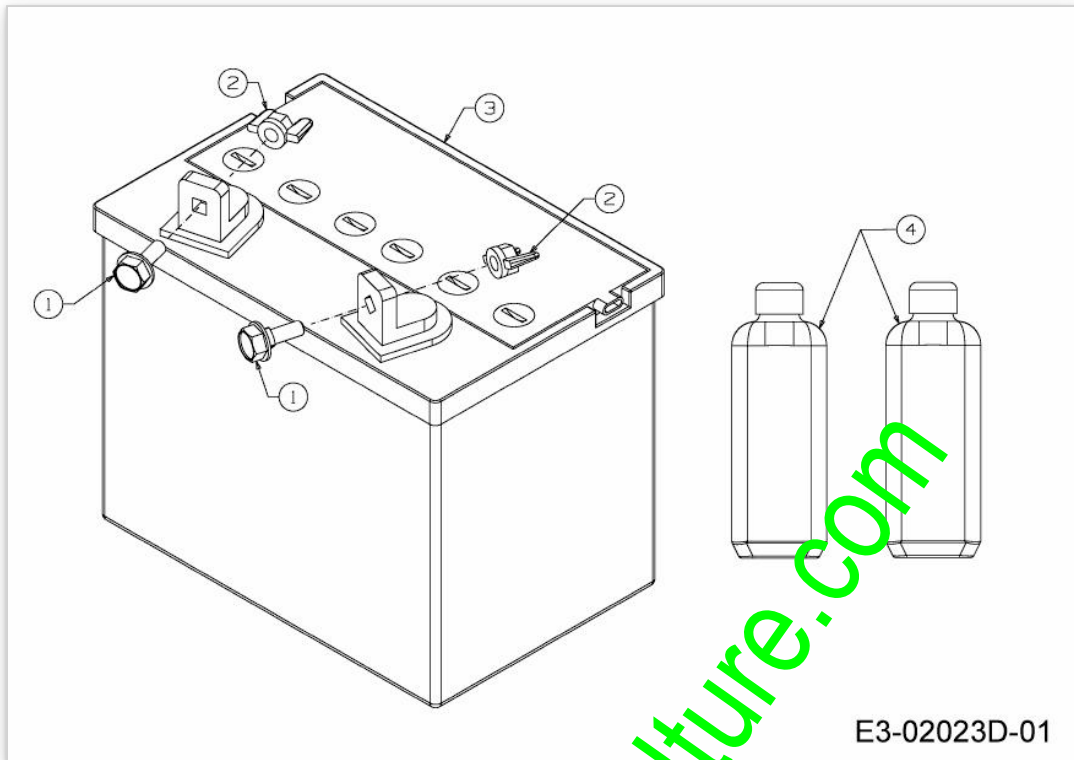

E3-02023D-01

www.emc-motoculture.com

Position	Numéro de lapièce	#	Appellation I	Appellation II
1	738-1132	2	AXE	FINISH:SPEC-100015
2	712-3087	2	ECROU PAPILLON	FINISH:KUNSTSTOFF SCHWARZ
3	725-1751	1	BATTERIE SECHE 220CCA	12V 16Ah
4	725-2064	2	BIDON ACIDE 1 LITRE	725-2064

www.emc-motoculture.com

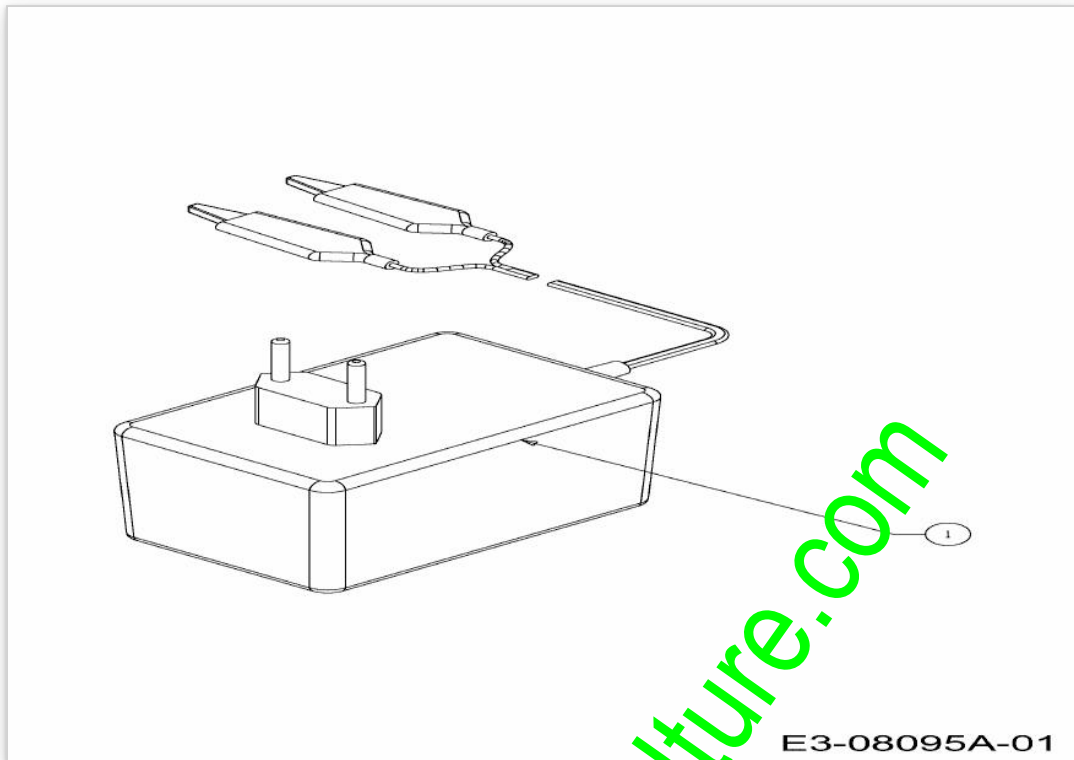

E3-08095A-01

www.emc-motoculture.com

Position	Numéro de lapièce	#	Appellation I	Appellation II
1	725-04098	1	CHARGEUR DE BATTERIE	*CE*

www.emc-motoculture.com

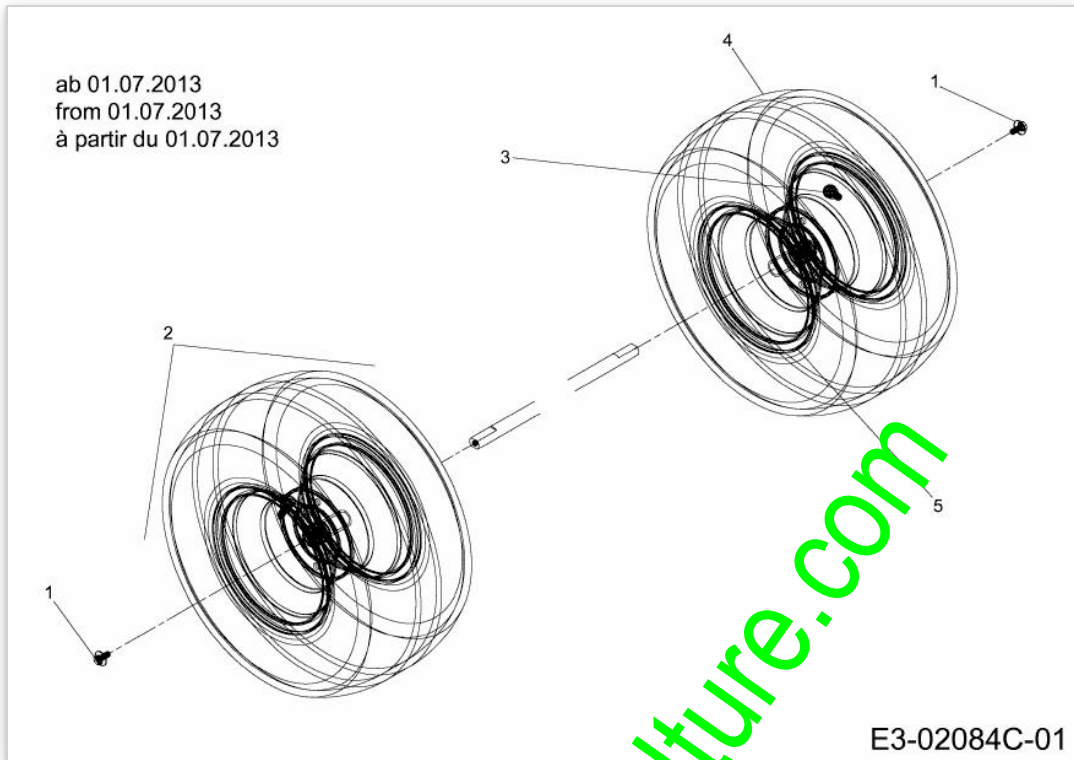

www.emc-motoculture.com

Position	Numéro de pièce	#	Appellation I	Appellation II
1	710-05339	2	VIS	GR5 E-TEIL-SET
2	734-0817	2	ROUE COMPL 18X9,50-8 ST ELEC	FINISH:SIEHE FARBVARIANTEN
3	734-0255	2	VALVE:PNEU	TR 412-P / 32.6mm / 934-0255
4	734-0448	2	PNEU 18*950*8	TURF SAVER 734-0448-0901
5	634-04369	2	JANTE 8.0x7.0x .750 ID	FINISH:LACKIERT

www.emc-motoculture.com

ab 11.01.2014
from 11.01.2014
à partir du 11.01.2014

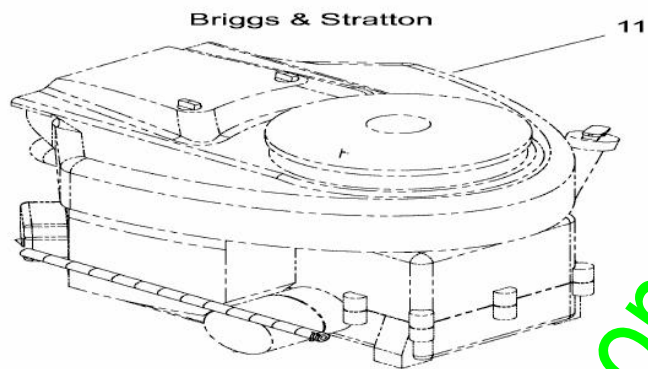

Model: 40R577
Type: 0009H1

E3-02474A-01

www.emc-motoculture.com

Position	Numéro de pièce	#	Appellation I	Appellation II
1	752B0009H1	1	B-MOTOR:B&S INTEK 7160 SERIES	40R577-0009-H1

www.emc-motoculture.com

bis 10.01.2014
to 10.01.2014
jusqu'au 10.01.2014

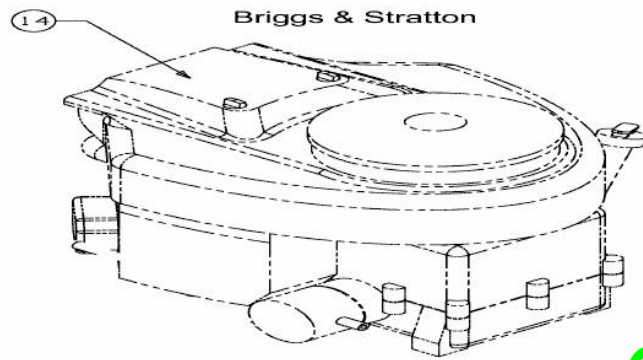

Model: 401577
Type: 0887-B1

E3-08307A-03

www.emc-motoculture.com

Position	Numéro de pièce	#	Appellation I	Appellation II
14	752B0887B1	1	MOTOR B&S 7160 SERIES	401577-3887-B1 (DUAL)

www.emc-motoculture.com

www.emc-motoculture.com