

13CN761F686 (2012) > PALIER 618-04474A

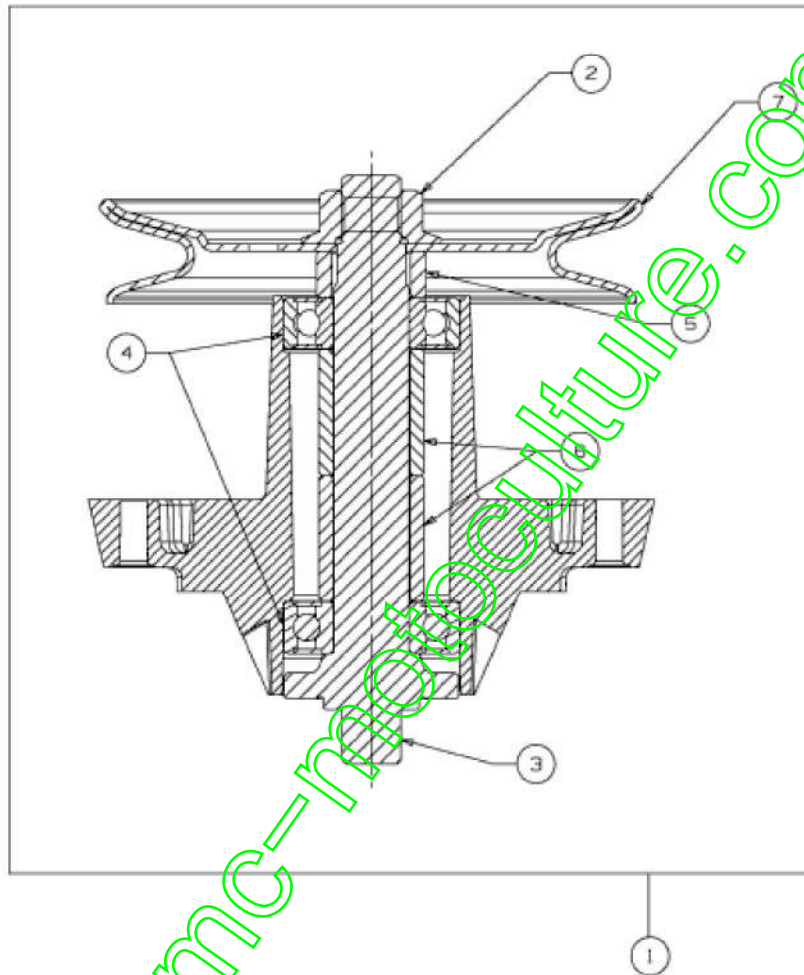

E3-07446A-01

Position	Numéro de pièce	Quantité	Désignation	Dimension
1	618-04474A	1	PALIER DE LAME COMPLET	M.KEILRIEMENSCHLEIFE 918-04474
2	712-0417A	1	ÜCROU HEX. AV. FLANC: 5/8-18	FINISH:MTD STD 701-01000
3	738-04241	1	AXE DE LAME	FINISH:GEÖLT
4	741-0919	2	ROULEMENT ; BILLES	FINISH:SIEHE SPEC.
5	750-04739	1	DOUILLE	FINISH:GEÖLT
6	750-1000	2	ENTRETOISE: .80x1.10x1.330	FINISH:GEÖLT
7	756-1188	1	POULIE DE COURROIE TRAPÜZ.	FINISH:SIEHE ZG.

www.emc-motoculture.com

13CN761F686 (2012) > DÉFLECTEUR

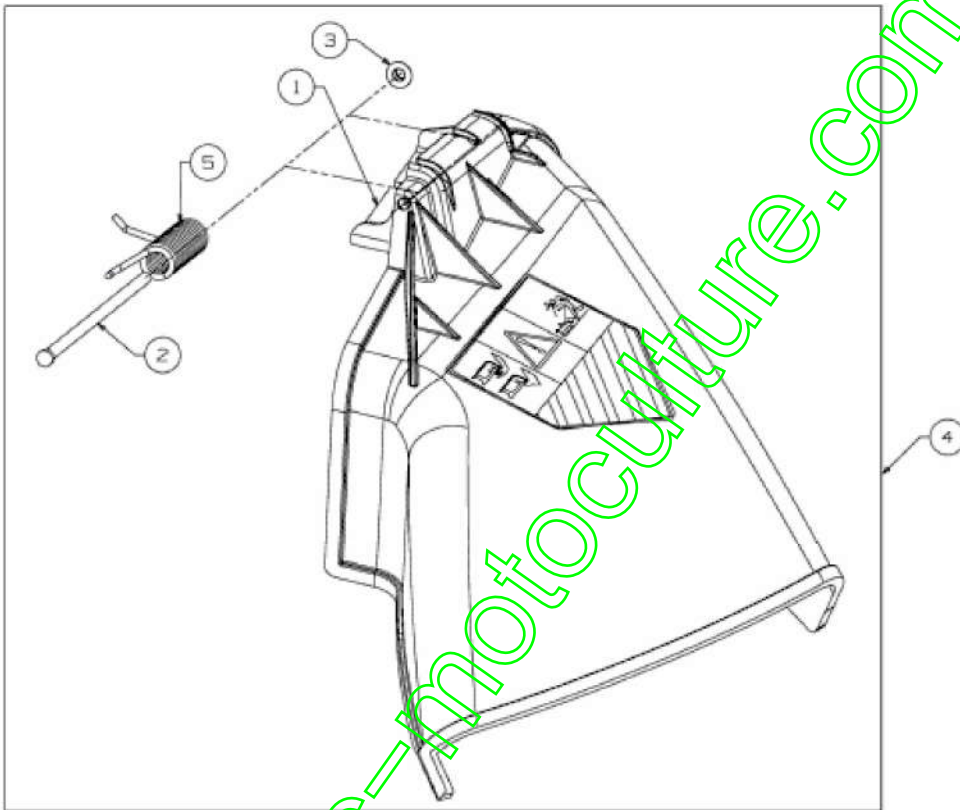

E3-04375A-01

Position	Numéro de pièce	Quantité	Désignation	Dimension
1	703-1693A	1	PLAQUE DE RACCORDE. -CHARNIÈRE	FINISH: 703-1693A-Z
2	711-0792	1	GOUJON	MTD SPEC 701-01000 911-0792
3	726-0106	1	COUVERCLE 1/4 "	FINISH:MTD STD 701- 01000
4	731-2541A	1	731-2541A	EXPORT
5	732-04537	1	RESSORT	FINISH:MTD STD 701- 01000

[www.emc-motoculture.com](http://www.emc-motoculture.com)

13CN761F686 (2012) > AXES

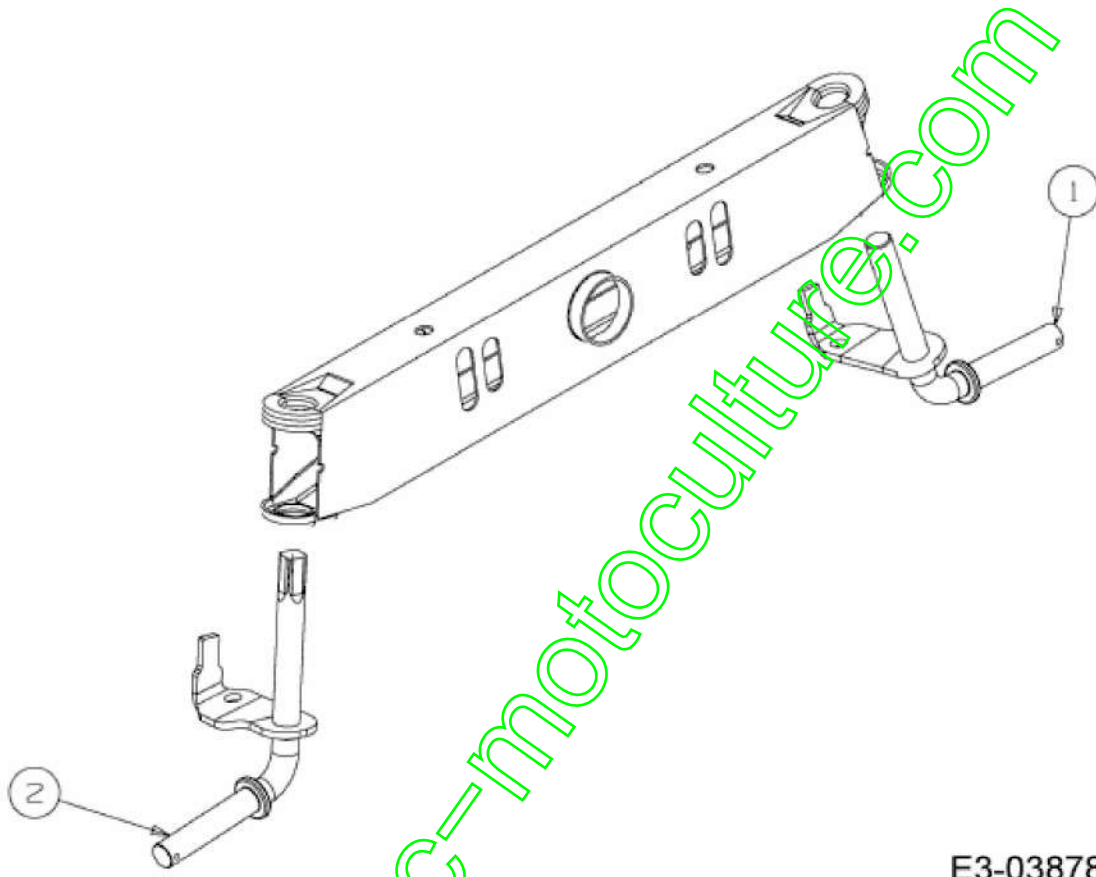

E3-03878B-01

Position	Numéro de pièce	Quantité	Désignation	Dimension
1	638-04007A	1	FINISH:LACKIERT MTD QUALITÄT	FINISH:LACKIERT MTD QUALITÄT
2	638-04008	1	AXE AVANT DROIT	638-04008-0637

[www.emc-motoculture.com](http://www.emc-motoculture.com)

13CN761F686 (2012) > AMPEREMETRE

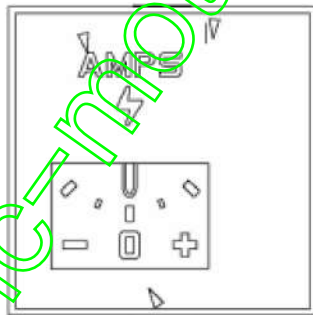
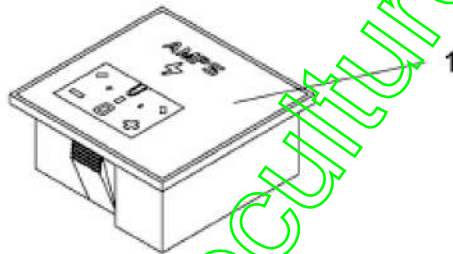
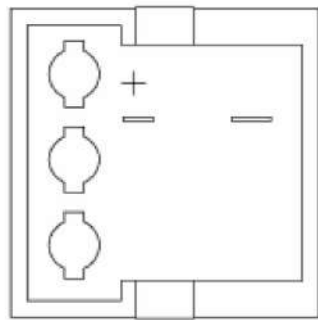

E3-07434A-01

Position	Numéro de pièce	Quantité	Désignation	Dimension
1	725-04156	1	INDIC. AMPÈREMÈTRE S. LUMIÈRE	925-04156

[www.emc-motoculture.com](http://www.emc-motoculture.com)



13CN761F686 (2012) > CONTACTEUR

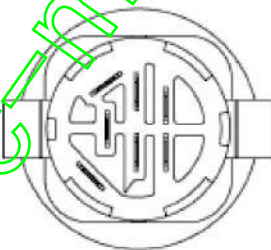
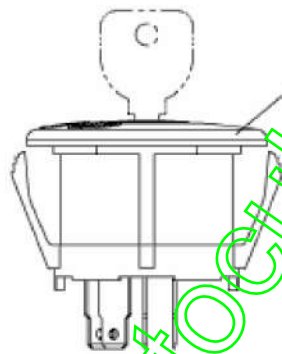
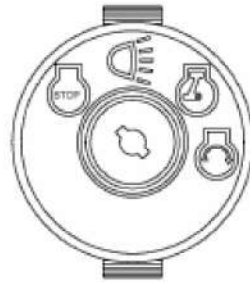

E3-04007A-01

Position	Numéro de pièce	Quantité	Désignation	Dimension
1	725-1741	1	CONTACTEUR A CLE	FINISH: 925-1741

[www.emc-motoculture.com](http://www.emc-motoculture.com)

13CN761F686 (2012) > CARTER DU CONTACTEUR

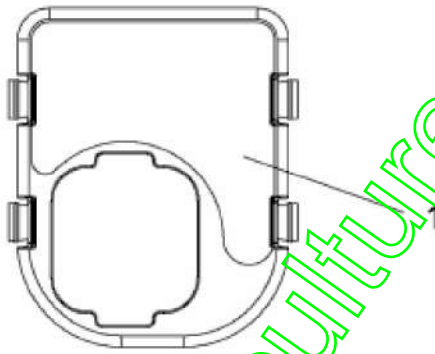
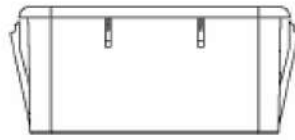

[www.emc-motoculture.com](http://www.emc-motoculture.com)

E3-07435A-01

Position	Numéro de pièce	Quantité	Désignation	Dimension
1	731-05241A	1	w/MAN PTO	w/MAN PTO

[www.emc-motoculture.com](http://www.emc-motoculture.com)

13CN761F686 (2012) > TABLEAU DE BORD PIÈCE SUPÉRIEURE

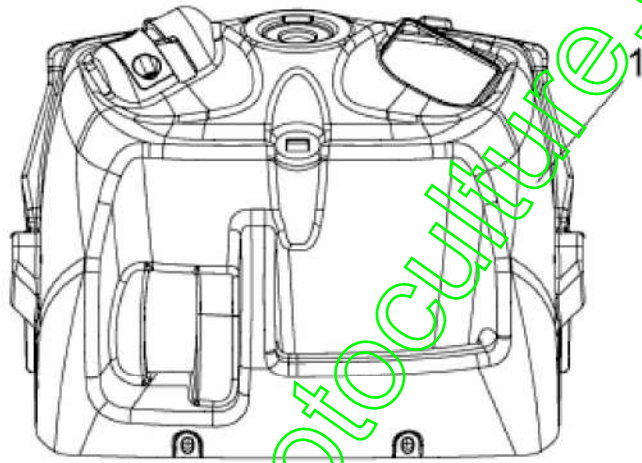

E3-07425A-01

Position	Numéro de pièce	Quantité	Désignation	Dimension
1	731-08054	1	TABLEAU DE BORD	FINISH:KUNSTSTOFF SCHWARZ

[www.emc-motoculture.com](http://www.emc-motoculture.com)

13CN761F686 (2012) > CABLE DE GAZ

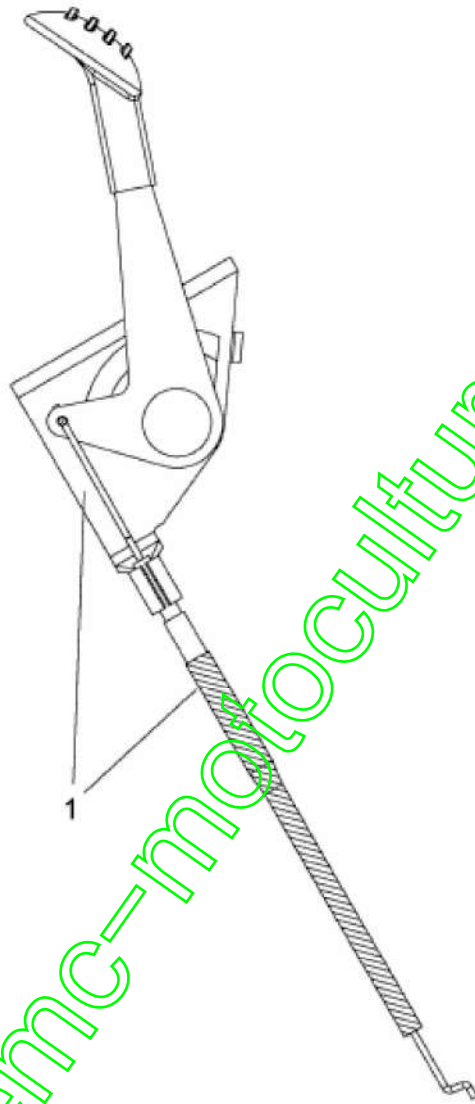

E3-03794A-01

[www.emc-motoculture.com](http://www.emc-motoculture.com)

Position	Numéro de pièce	Quantité	Désignation	Dimension
1	746-04406	1	CABLE ACCELERATEUR	FINISH:

[www.emc-motoculture.com](http://www.emc-motoculture.com)



13CN761F686 (2012) > COMMANDE DE CHOKE

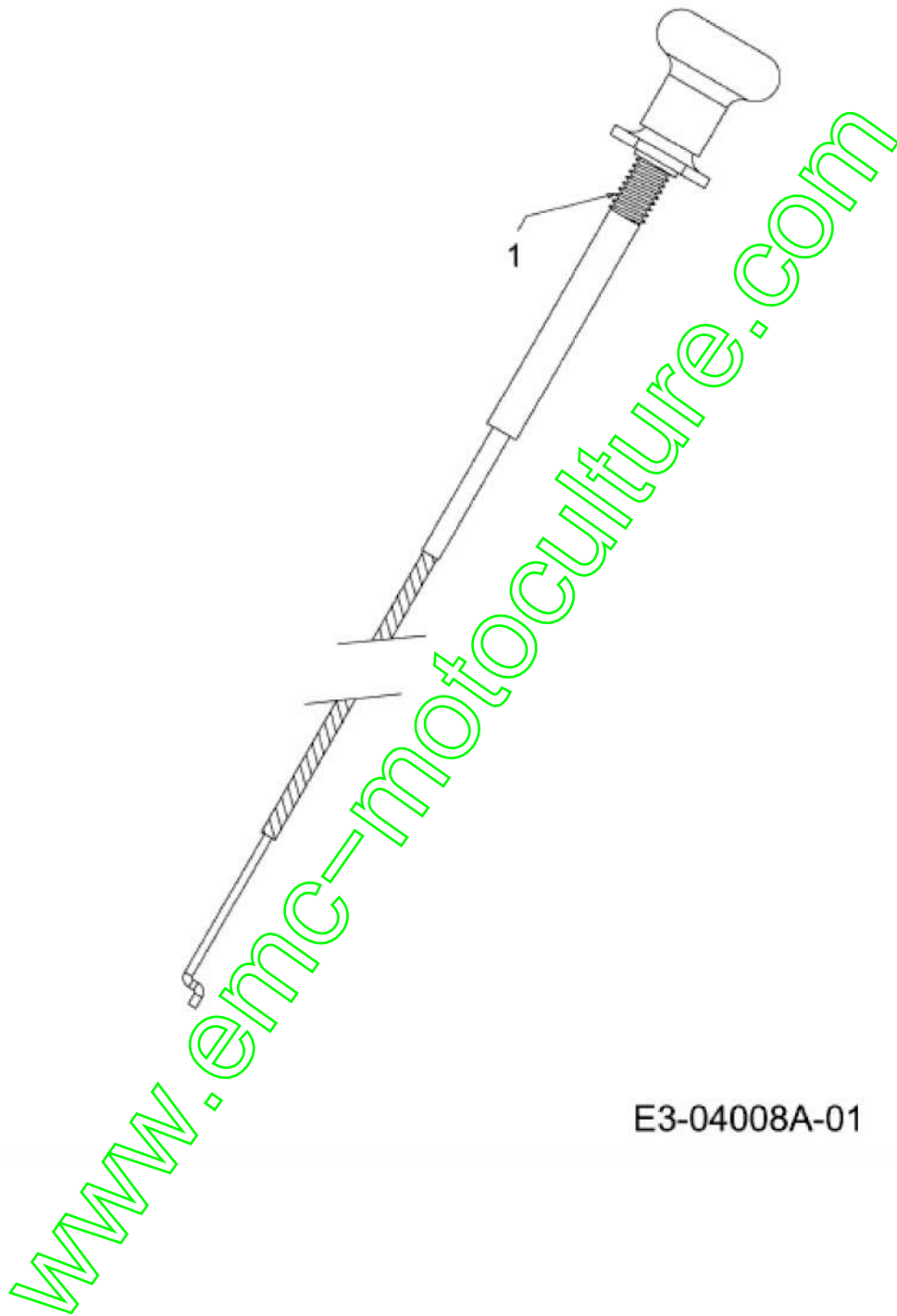

E3-04008A-01

Position	Numéro de pièce	Quantité	Désignation	Dimension
1	746-1089	1	CABLE STARTER	29.0" LG x 1.50 EXT

[www.emc-motoculture.com](http://www.emc-motoculture.com)

13CN761F686 (2012) > ROUES AVANT 15X6

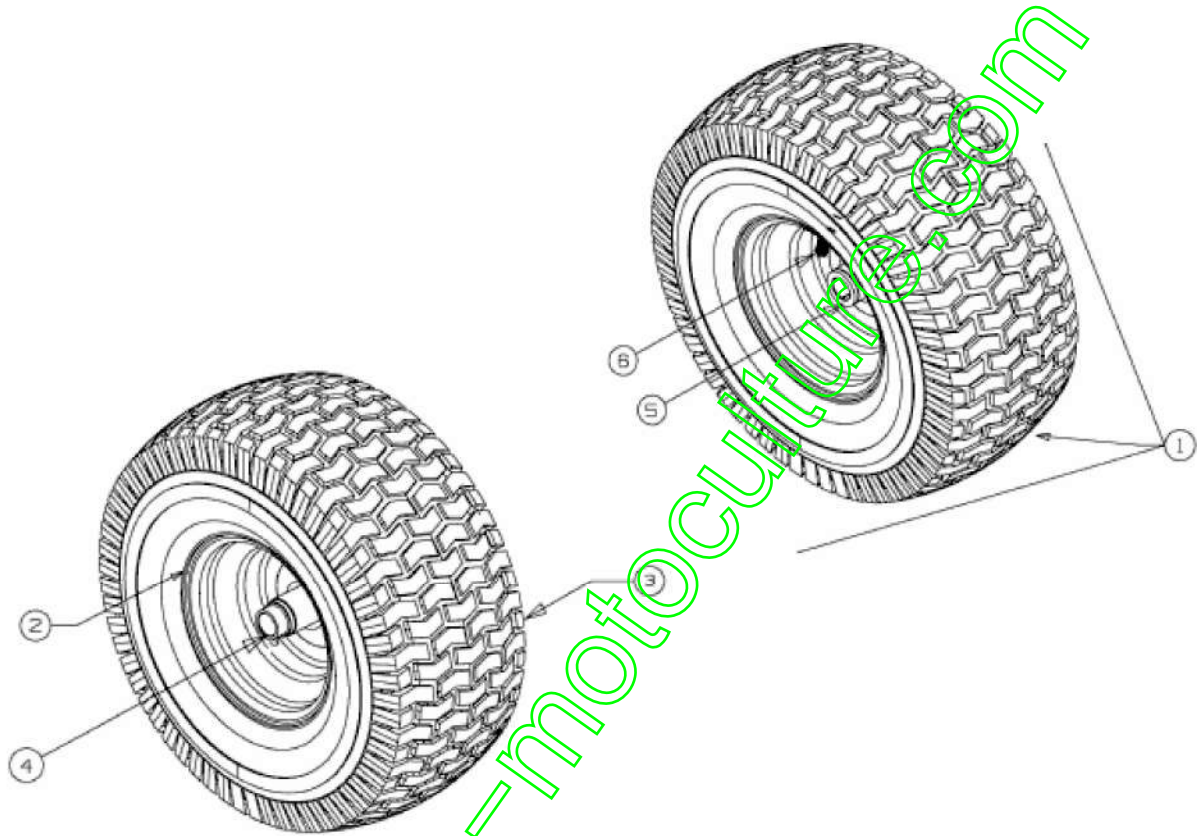

E3-02085B-01

Position	Numéro de pièce	Quantité	Désignation	Dimension
1	634-04086	2	ROUE CPLT	SHL
2	634-04081	1	JANTE CPLT	GLEITLAGER SCHWEIßT EIL
3	734-1731	1	PNEU 15X600X6 DICO M ULTI-TRAC	FINISH:
4	741-0990B	1	BAGUE DE ROUE AVEC GRAISSEUR	m.SCHMIERNIPPEL:FINIS H SCHWARZ
5	741-0516B	1	BAGUE DE ROUE .760x 1.00x1.20	FINISH: SCHWARZ
6	734-0255	1	VALVE:PNEU	TR 412-P / 32.6mm / 934-0 255

www.emc-motoculture.com

13CN761F686 (2012) > BATTERIE

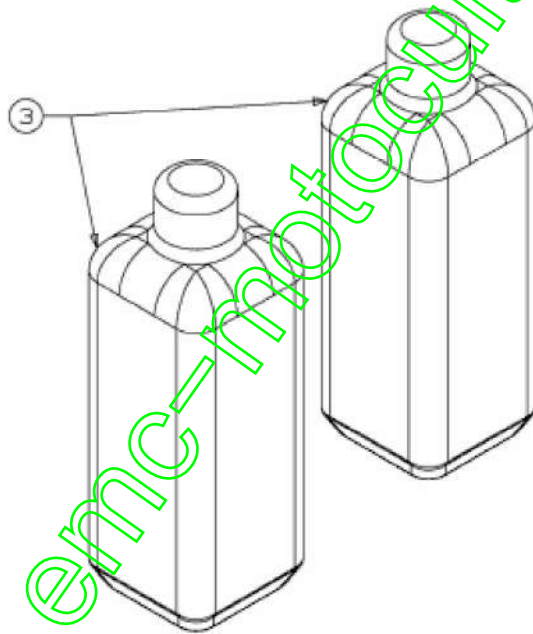
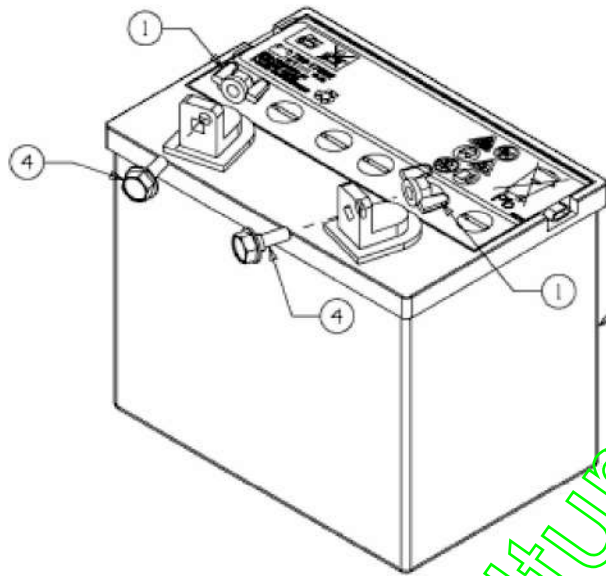

E3-02343B-01

Position	Numéro de pièce	Quantité	Désignation	Dimension
1	712-3087	2	ÜCROU PAPILLON	FINISH:KUNSTSTOFF SCHWARZ
2	725-1705E	1	BATTERIE:U1:150 CCA TROCKEN	BELÜFTUNG OBEN
3	725-2064A	2	BIDON D ACIDE 1.05 LITRE	SONDERABFÜLLUNG (35.5 oz)
4	738-1132	2	AXE	FINISH:PHOS & OIL SIEHE CODE

[www.emc-motoculture.com](http://www.emc-motoculture.com)

13CN761F686 (2012) > VOLANT

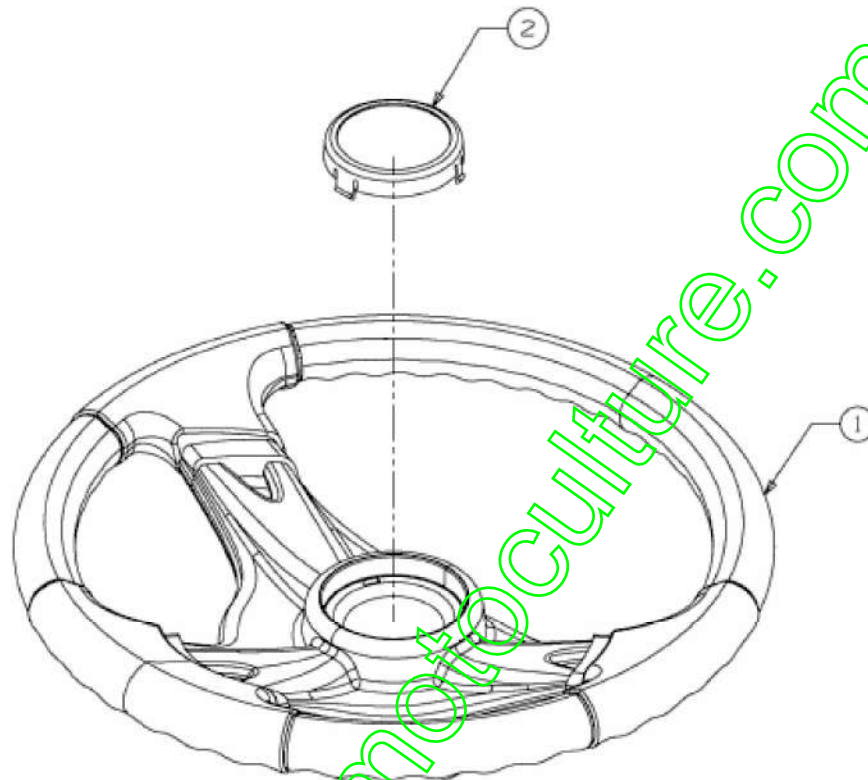

www.emc-motoculture.com

E3-02015A-01

Position	Numéro de pièce	Quantité	Désignation	Dimension
1	631-04028	1	VOLANT	STD GRIP:FINISH SCHWARZ
2	731-04039	1	CAPUCHON DE VOLANT SANS LOGO	FINISH:KUNSTSTOFF SCHWARZ

[www.emc-motoculture.com](http://www.emc-motoculture.com)



13CN761F686 (2012) > RELEVAGE PLATEAU DE COUPE

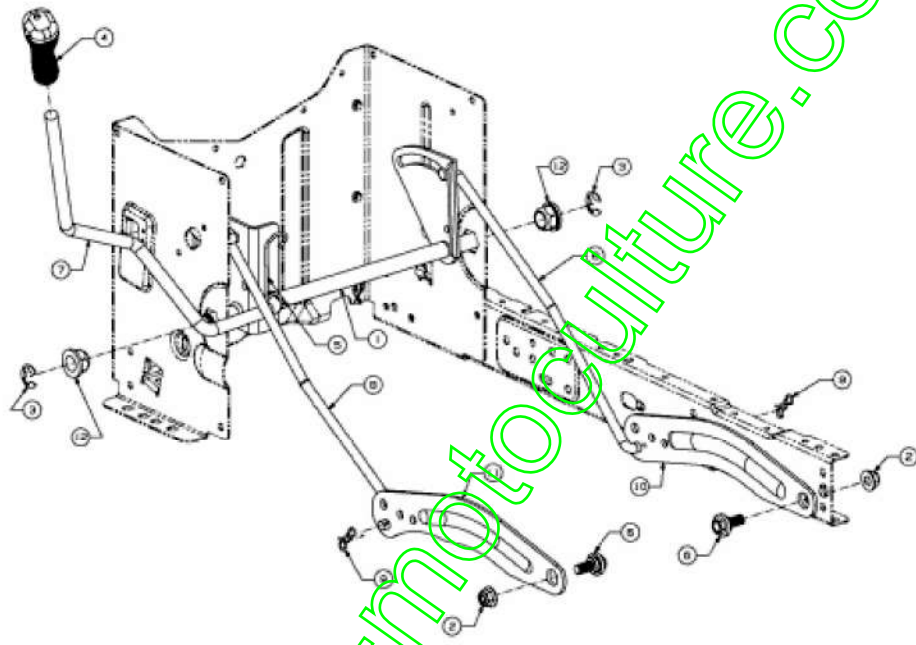

E3-02741C-01

Position	Numéro de pièce	Quantité	Désignation	Dimension
1	683-04155 A	1	ARBRE CPL.:LEVÜE LT-5	FINISH:LACKIERT
2	712-04065	2	ÜCROU HEXAGONAL	FINISH:SPEC-101616 9 12-04065
3	716-0106A	2	CIRCLIPS	FINISH:MTD SPEC 701 -01001
4	720-0311	1	POIGNÜE: 1/2	FARBE: SCHWARZ VIN YL
5	732-04225	1	RESSORT	FINISH:MTD STD 701-0 1006
6	738-04130	2	VIS .625X.175:3/8-16	FINISH:701-01002
7	747-04282	1	LEVIER DE RELEVAGE LT -5	FINISH:701-01000
8	747-04393	2	TRINGLE DE RELEVAGE	FINISH:MTD STD 701-0 1006
9	714-04040	2	GOUPILLE	FINISH:VERZINKT
10	783-04711 C	1	NOIR	FINISH:LACKIERT MT D QUALITÄT
11	783-04494 C	1	NOIR	FINISH:LACKIERT MT D QUALITÄT
12	741-0225	2	BAGUE HEXAGONALE TE FLON 6 PANS	FINISH:KUNSTSTOFF SCHWARZ

13CN761F686 (2012) > SYSTÈME DIRECTION

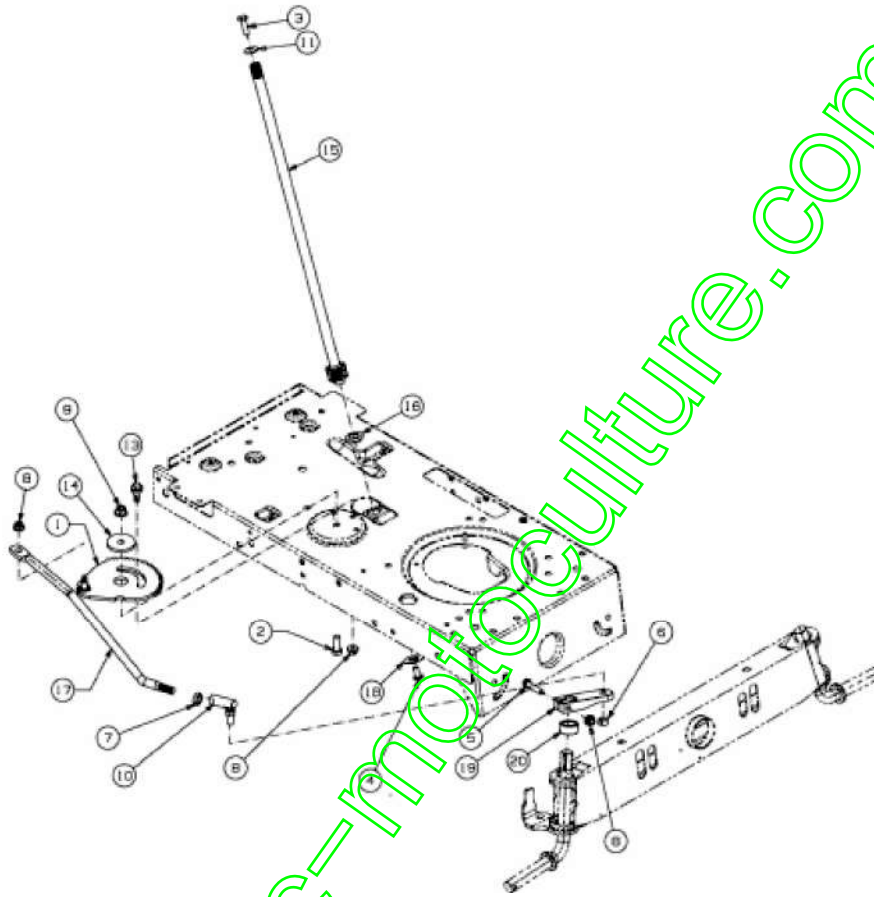

E3-02700C-01

Position	Numéro de pièce	Quantité	Désignation	Dimension
1	617-04094	1	SEGMENT DE DIRECTION	SCHWEISSTEIL:PHOS & OIL
2	710-0514	1	VIS HEX.:3/8-16:1.00:GR5:STD	FINISH:MTD STD 701-01000
3	710-0643	1	VIS HEX.: 5/16-18:1.00:GR5	FINISH: MTD STD 701-01000
4	710-1309	1	VIS	FINISH:MTD STD 701-01000
5	710-3180	1	VIS HEX. 5/16-18:1.75:GR5:STD	SPEC-701-01000 or SPEC 101616
6	712-0214	1	ECROU	FINISH:701-01000
7	712-0240	1	ÛCROU HEX.: 7/16-20:GR2	FINISH:MTD STD 701-01000
8	712-04063	3	ÛCROU HEX. AVEC FLANC	FINISH:MTD STD SPEC-101616
9	712-04065	1	ÛCROU HEXAGONAL	FINISH:SPEC-101616 912-04065
10	723-0448A	1	ROTULE DE DIRECTION 7/16-20	FINISH:GELB VERZINKT
11	736-0242	1	RONDELLE CONIQUE.340X.872X.060	FINISH:MTD STD 701-01001
13	738-04141	1	AXE	FINISH:701-01000
14	738-04162A	1	ENTRETOISE .8840 x .190	FINISH:IN ÖL GETAUCHT
15	738-0919A	1	COLONNE DE DIRECTION	FINISH:PHOS & OIL
16	741-04124	1	PALIER DE BRIDE	FINISH:PLAIN
17	747-05385	1	TRINGLE DE DIRECTION	FINISH:701-01007
18	748-0389	1	BAGUE	FINISH:GEÖLT
19	748-04065637	1	BIELLETTE DE DIRECTION	SCHWARZ LACKIERT
20	748-04068	1	DOUILLE .71IDX.125 ODX.56 LG	FINISH:SPEC 701-01010

13CN761F686 (2012) > JUPE

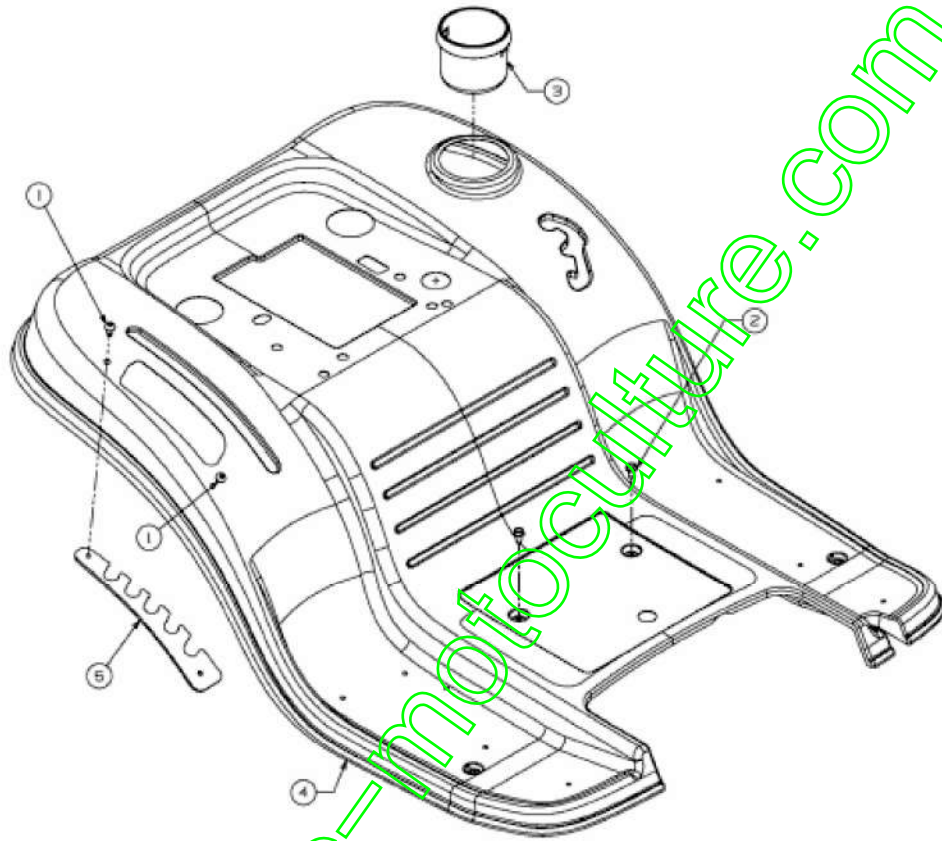

E3-02725D-01

Position	Numéro de pièce	Quantité	Désignation	Dimension
1	710-05070	2	VIS	FINISH: SCHWARZ SPEC 701-01010
2	710-0599	2	VIS à SIX PANS CREUX	MTD SPEC-701-01002 or 101617
3	731-04591A	1	PORTE GOBELET	FINISH: KUNSTSTOFF SCHWARZ
4	783-04587D	1		
5	783-04843	1	5 FACH	FINISH LACKIERT

[www.emc-motoculture.com](http://www.emc-motoculture.com)

13CN761F686 (2012) > MARCHEPIED GARNITURE

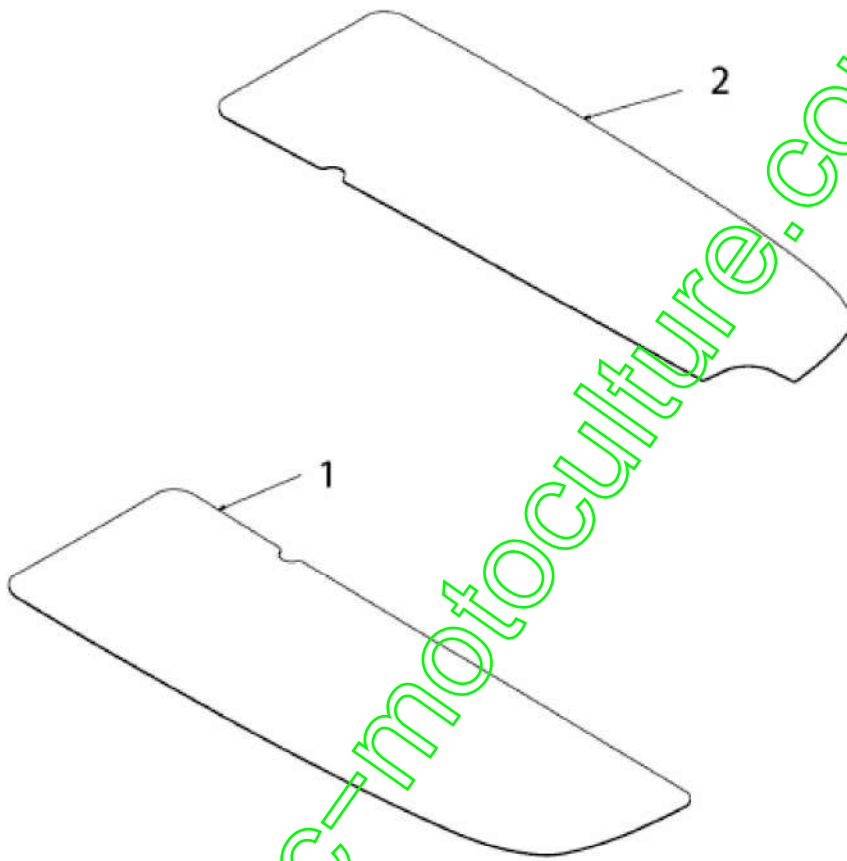

[www.emc-motoculture.com](http://www.emc-motoculture.com)

E3-02721A-01

Position	Numéro de pièce	Quantité	Désignation	Dimension
1	723-04025	1	MARCHE PIED DROIT E	FARBE: SCHWARZ
2	723-04026	1	MARCHE PIED GAUCHE E	FARBE: SCHWARZ

[www.emc-motoculture.com](http://www.emc-motoculture.com)



13CN761F686 (2012) > ASSORTIMENT ÉLECTRIQUE

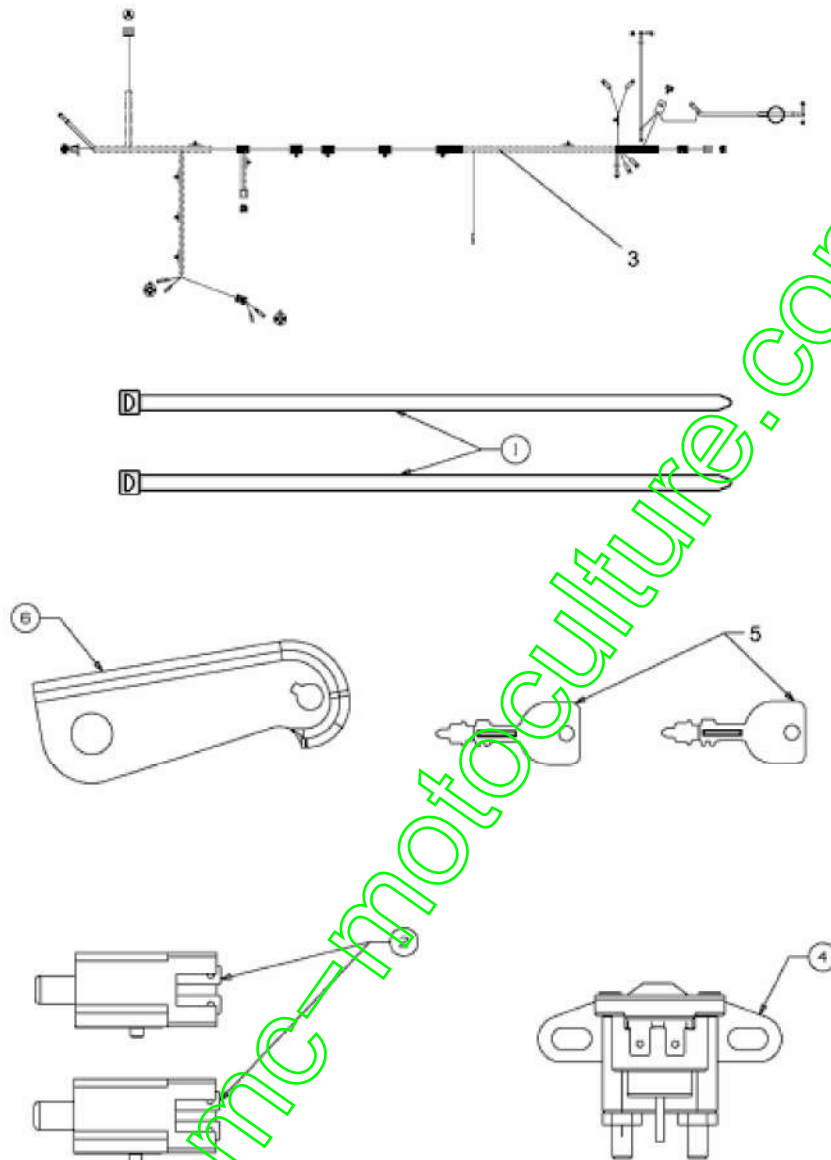

E3-02735F-01

Position	Numéro de pièce	Quantité	Désignation	Dimension
1	725-0157	2	COLLIER DE SERRAGE3/ 16X0.5X7.4	MATERIAL:NYLON-S CHWARZ
2	725-04363	2	SECURITE	FINISH:SIEHE ZG.
3	725-04433F	1	FAISCEAU COMPLET	
4	725-04439	1	COMMUTATEUR MAGNÜ TIQUE	12V:100 AMP
5	725-1744A	2	CLÜ DE CONTACT	FINISH:
6	783-06991	1	SUPPORT	SD-TR./HYDRO:VERZ INKT

[www.emc-motoculture.com](http://www.emc-motoculture.com)

13CN761F686 (2012) > RÉSERVOIR

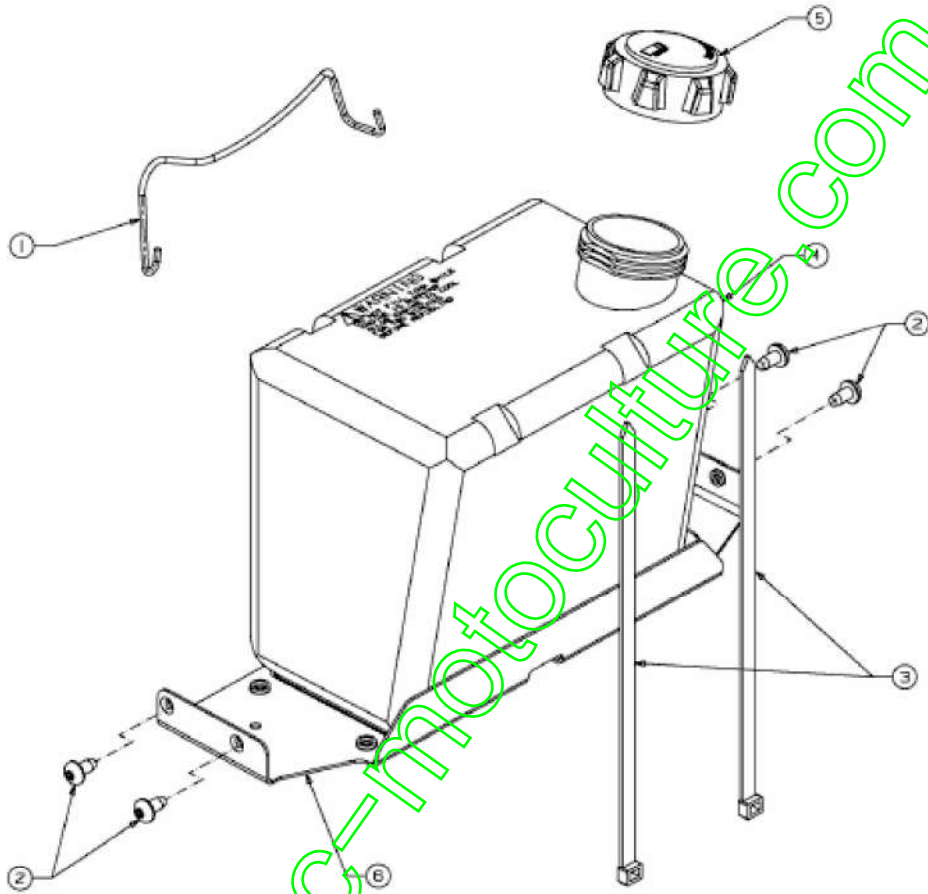

E3-07426A-01

Position	Numéro de pièce	Quantité	Désignation	Dimension
1	683-04448	1	TRINGLE SUPPORT B ATTERIE	FINISH:LACKIERT MTD Q UALITÄT
2	710-05070	4	VIS	FINISH:SCHWARZ SPEC 701-01010
3	726-0230	2	COLLIER	FINISH:SCHWARZ
4	751-0553	1	RESERVOIR 5 L ENV.	FINISH:NATUR SIEHE Z G.
5	751-0603A	1	BOUCHON ESSENCE	FINISH:KUNSTSTOFF SC HWARZ
6	783-07083	1		

[www.emc-motoculture.com](http://www.emc-motoculture.com)

13CN761F686 (2012) > ENJOLIVEURS

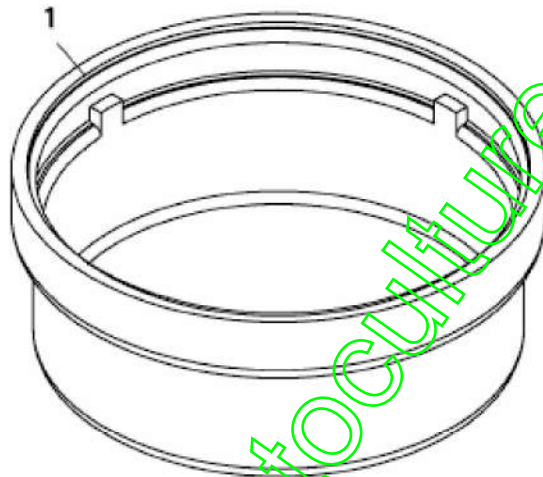

[www.emc-motoculture.com](http://www.emc-motoculture.com)

E3-02002B-01

Position	Numéro de pièce	Quantité	Désignation	Dimension
1	731-0484A	2	ENJOLIVEUR DEV ANT	FINISH: SCHWARZ 931-0 484A

[www.emc-motoculture.com](http://www.emc-motoculture.com)

13CN761F686 (2012) > PLATEAU DE COUPE F (38"/96CM)

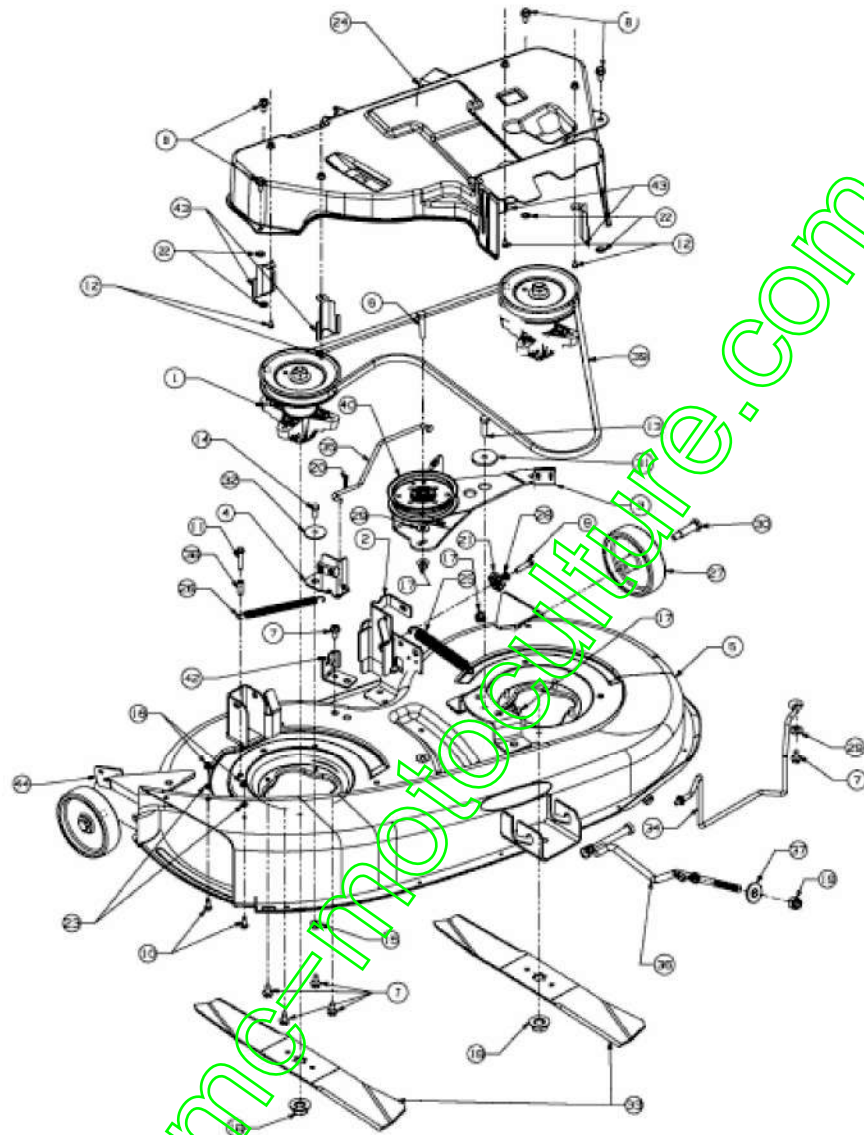

E3-02763D-01

Position	Numéro de pièce	Quantité	Désignation	Dimension
1	618-04474 A	2	PALIER DE LAME COMPLETE	M.KEILRIEMENSCHLEIBE 918-04474
2	683-0254B	1	SUPPORT	SCHWEISSTEIL FINISH:LACKIERT
3	683-04138 B	1	983-04138B	NIET-TEIL
4	983-04167	1	FREIN DE LAME DROITE	GENIETET
5	683-04264	1	CARTER DE COUPE	SCHWEISSTEIL: FINISH:LACKIERT
6	710-0347	1	VIS HEX. 3/8-16:1.75:GR5:STD	FINISH:MTD STD 701-01000
7	710-04484	10	VIS HEX. TT:5/16-18:1.75:HXIND	FINISH:MTD SPEC-701-01002
8	710-05045 A	4	VIS	FINISH:701-01002
9	710-0528	1	VIS HEX. 5/16-18:1.25:GR5:STD	FINISH:STD 701-01000 910-0528
10	710-0751	2	VIS HEX. 1/4-20:1.620:GR5:STD	FINISH:701-01000
11	710-0778	1	VIS HEX. TT:1/4-20:1.500	FINISH:MTD SPEC-701-01002
12	710-0919	4	VIS HEX. B:#10-16:0440:HEX	FINISH:MTD SPEC 701-01002
13	710-3005	1	VIS HEX.HHCS:3/8-16:1.25 GR5STD	FINISH:MTD SPEC-701-01000
14	710-3008	1	VIS 5/16-18:1.75:GR5:STD	FINISH:MTD STD 701-01000
15	712-04063	1	ÜCROU HEX. AVEC FLANC	FINISH:MTD STD SPEC-101616
16	712-04064	2	ÜCROU HEXAGONAL	GRF:FINISH:701-01000 912-04064
17	712-04065	4	ÜCROU HEXAGONAL	FINISH:SPEC-101616 912-04065
18	712-0417A	2	ÜCROU HEX. AV. FLANC: 5/8-18	FINISH:MTD STD 701-01000
19	712-04243	1	ECROU	



Position	Numéro de pièce	Quantité	Désignation	Dimension
				FINISH:MTD STD 701-01000
20	714-0104	1	GOUPILLE	FINISH:PHOS AND OIL
21	717-04074	1	PIGNON HAUTEUR PLATEAU	FINISH:SIEHE ZG. 917-04074
22	726-0201	4	RONDELLE .3125 ID	FINISH:SPEC-101617
23	726-0233	2	RONDELLE	FINISH:PHOS AND OIL
24	731-05699 B	1	COUVERCLE PLASTIQUE PLATEAU DE	FINISH: SCHWARZ
25	732-04280 B	1	RESSORT .75 OD X 6.375L G	FINISH: 701-01006
26	732-04287	1	RESSORT	SPEC 701-01006 OR 701-01000
27	734-0973	2	ROULETTE DE PLATEAU	FINISH:KUNSTSTOFF SCHWARZ
28	736-0119	1	RONDELLE	FINISH:MTD STD 701-01001
29	736-0300	3	RONDELLE	FINISH:MTD SPEC-100015
30	738-0373	2	VIS / TÙ PAULE .496x1.525:3/8-16	FINISH:MTD STD 701-01000
31	738-04162 A	1	ENTRETOISE .8840 x .190	FINISH:IN ÖL GETAUCHT
32	738-04166	1	ENTRETOISE .5000 X .1475	FINISH: IN ÖL GETAUCHT
33	742-0675	2	LAME COUPE 96 CM	STAR 6 PT 942-0675
34	747-04332 A	1	TRINGLE GUIDE DE COURROIE 38"	FINISH:701-01000
35	747-04381	1	TIGE DE FREIN 38"	FINISH:701-01000
36	747-04875	1	TRINGLE	701-01006 OPTIONAL SPEC-100015
37	748-04069	1	RONDELLE	FINISH:701-01001 LT-5
38	750-0566A	1	ENTRETOISE	FINISH:VERZINKT SIEHE ZG.
39	754-04062	1		954-04062

Position	Numéro de pièce	Quantité	Désignation	Dimension
			COURROIE DE COUPE 96 CM	
40	756-04129 B	1	POULIE DE TENSION	KUGELGELAGERT:FINISH
42	783-04740	1	FÜHRUNGSBL:BOWDENZUG:DECKBETÄT	FINISH:LACKIERT
43	783-05497 -Z	4	SUPPORT	FINISH:VERZINKT
44	783-1025	1	PLAQUE ACCROCHE DEFL ecteur	FINISH:VERZINKT

[www.emc-motoculture.com](http://www.emc-motoculture.com)

13CN761F686 (2012) > COUVERCLES DE PROTECTION PLATEAU DE COUPE F (38"/96CM)

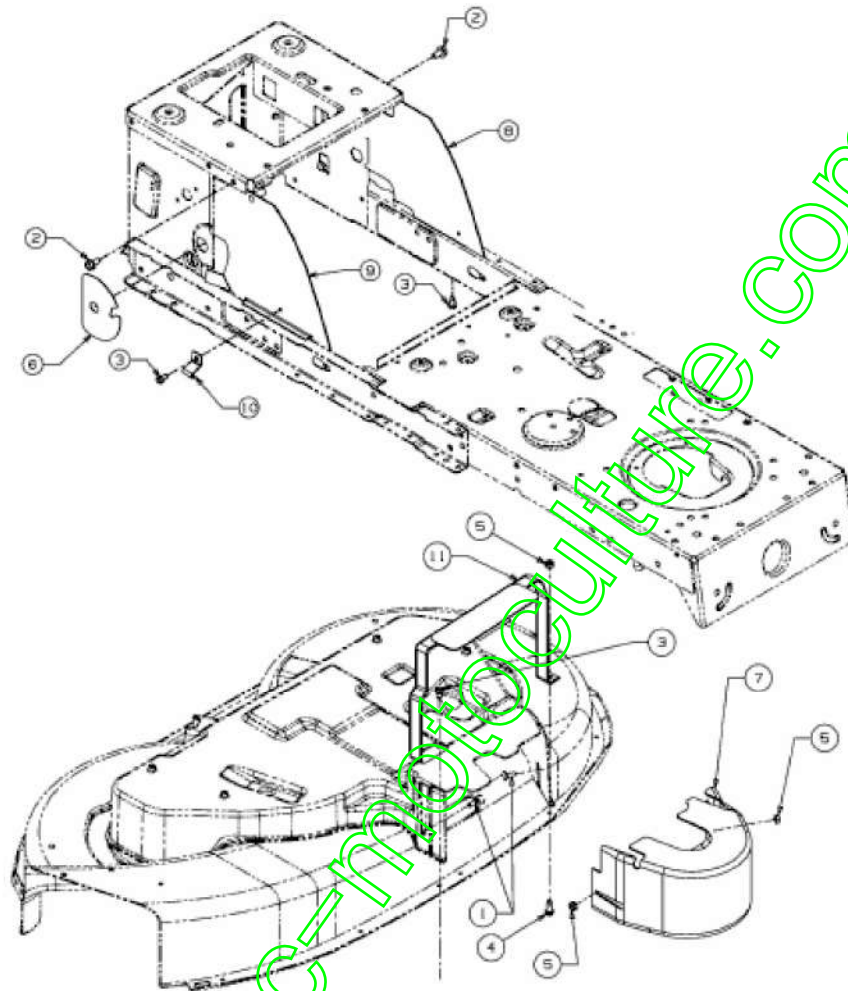

E3-03850C-01

Position	Numéro de pièce	Quantité	Désignation	Dimension
1	710-0134	2	VIS à Tête PLATE	FINISH:MTD STD 701-01000
2	710-04484	2	VIS HEX. TT:5/16-18:0.750:HXIND	FINISH:MTD SPEC-701-01002
3	710-0599	3	VIS à SIX PANS CREUX	MTD SPEC-701-01002 or 101617
4	710-0642	1	VIS1/4-20:0.750	MTD SPEC-701-01002 910-0642
5	712-0271	3	ECROU 1/4-20"+ DISQUE DENTÉ	FINISH:MTD STD 701-010015
6	731-05586	1	COUVERCLE PLASTIQUE	KUNSTSTOFFSCHEIBE Ø115mm (DÖ)
7	731-05613 A	1	PROTEGE COURROIE	FINISH:Schwarz
8	783-05085	1	JOUE ARRIERE GAUCHE	GETRIEBE FINISH:LACKIERT
9	783-05086 A	1	RAHMENABDECKUNG:RE:LT-5 TRANSM	FINISH:LACKIERT
10	783-05107	1	SUPPORT	FINISH:PLAIN *
11	783-05295	1	SUPPORT	FINISH:LACKIERT

www.emc-motors.com

13CN761F686 (2012) > ENTRAÎNEMENT DE ROULEMENT

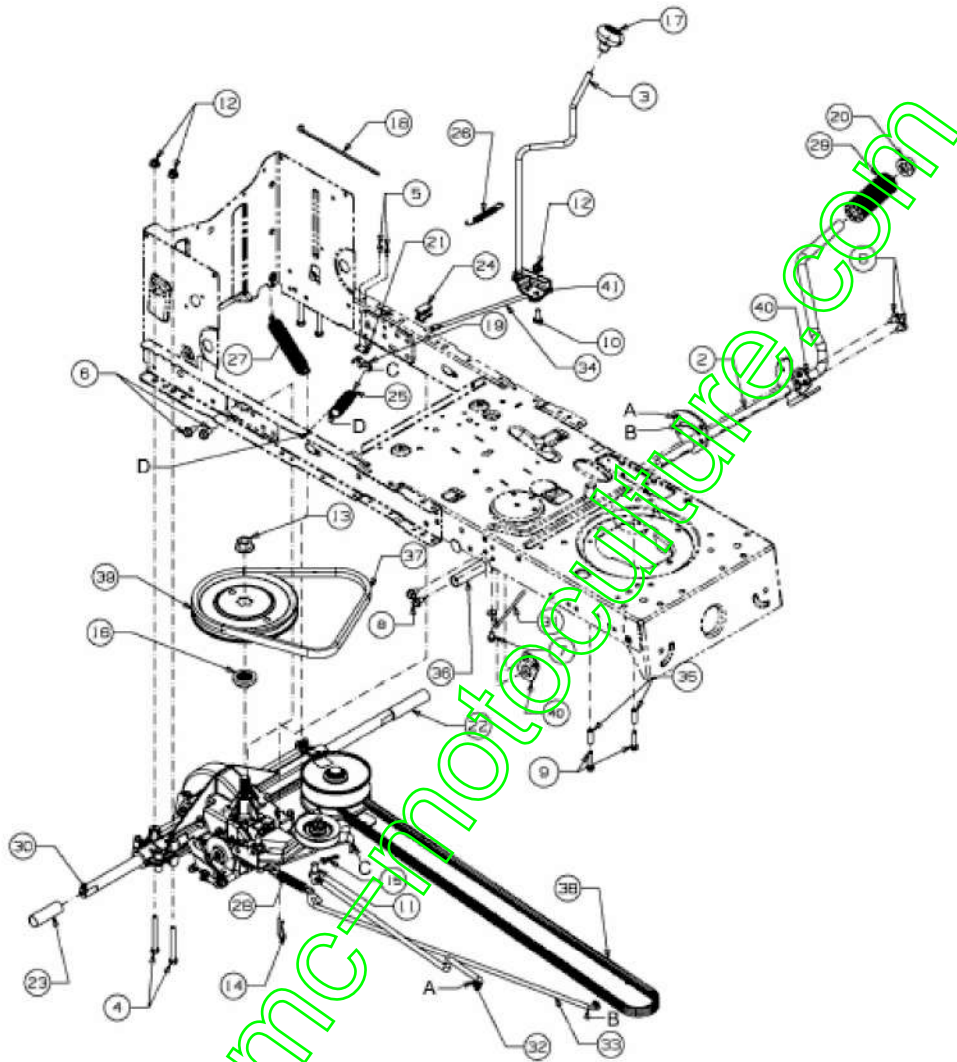

E3-06545B-01

Position	Numéro de pièce	Quantité	Désignation	Dimension
2	647-04034 C	1	FAHRANTRIEBSPEDAL G ESCHW LT-5	SCHWEIßTEIL FINISH: LACKIERT
3	647-04266	1	LEVIER INVERSEUR	FINISH:701-01000
4	710-0176	4	VIS HEX.:5/16-18:2.75:GR 5:STD	(21.1441.82) FINISH:70 1-01000
5	710-0227	2	VIS	FINISH:MTD STD 701-0 1002
6	710-04484	2	VIS HEX. TT:5/16-18:.750: HXIND	FINISH:MTD SPEC-701 -01002
7	710-0599	1	VIS   SIX PANS CREUX	MTD SPEC-701-01002 or 101617
8	710-0604A	4	VIS 5/16-18:0.625	FINISH:MTD SPEC-701 -01002
9	710-0809	2	VIS HEX. TT:1/4-20:1.250: HXIND	FINISH:MTD STD 701-0 1002
10	710-3008	1	VIS 5/16-18:.75:GR5:STD	FINISH:MTD STD 701-0 1000
11	711-04075 A	1	EMBOUT	FINISH:MTD SPEC 701- 01000
12	712-04063	5	ÜCROU HEX. AVEC FLAN C	FINISH:MTD STD SPEC -101616
13	712-0700	1	ÜCROU HEXAGONAL	FINISH:701-01000 912- 0700
14	714-0209	1	GOUPILLE FENDUE	FINISH:GELBVERZINK T 914-0209
15	714-04040	1	GOUPILLE	FINISH:VERZINKT
16	718-04407	1	MOYEU: POULIE:5/8 DEN TELURE	VERZAHNUNG
17	720-04028	1	POIGNEE INVERSEUR	FINISH:SCHWARZ
18	725-0157	1	COLLIER DE SERRAGE3/ 16X0.5X7.4	MATERIAL:NYLON-SC HWARZ
19	725-1644	1	INTERRUPTEUR DE SÜC URITÜ	FINISH:VERZINKT SIE HE ZG.
20	726-0214	1	BOUCHON	FINISH:SCHWARZ
21	726-0320	1	PLAQUE D'ISOLATION	

Position	Numéro de pièce	Quantité	Désignation	Dimension
				FINISH:NATUR ODER SCHWARZ
22	731-04602	1	ENTRETOISE	FINISH:PP SCHWARZ
23	731-04604	1	ENTRETOISE	FINISH:PP SCHWARZ
24	731-06894	1	SUPPORT PLASTIQUE	FINISH:NATUR
25	732-04306	1	RESSORT	FINISH:MTD STD 701-01006
26	732-04488	1	RESSORT DE TRACTION	FINISH:701-01006
27	732-04746	1	RESSORT	FINISH:MTD STD 701-01000
28	732-0716D	1	RESSORT	FINISH:MTD STD 701-01006
29	735-0239	1	CAOUTCHOUC/PEDALE 4	FINISH:Schwarz
31	747-04969	1	TRINGLE	FINISH:701-01006
32	747-05186	1	TRINGLE	FINISH:MTD STD 701-01000
33	747-05188	1	TRINGLE DE FREIN	FINISH:701-01006 or E-COAT
34	747-05244	1	TRINGLE	FINISH:701-01000
35	750-0566A	2	ENTRETOISE	FINISH:VERZINKT SIEHE ZG.
36	750-0802	1	ENTRETOISE / .640IDX.760DX2.63	FINISH:KUNSTSTOFF SCHWARZ
37	754-0241A	1	COURROIE VARIATEUR/BOITE	FINISH:SIEHE ZG. 954-0241A
38	754-04249A	1	COURROIE MOTEUR VARIATEUR	FINISH
39	756-04002	1	POULIE DE PONT	FINISH:SIEHE ZG. 956-04002
40	783-04536B	2	STÜTZBLECH:PEDAL:LT-5	FINISH:LACKIERT MTD QUALITÄT
41	783-04595	1	SUPPORT DE LEVIER	FINISH:701-01000

13CN761F686 (2012) > BOÎTE DE VITESSES, VARIATEUR

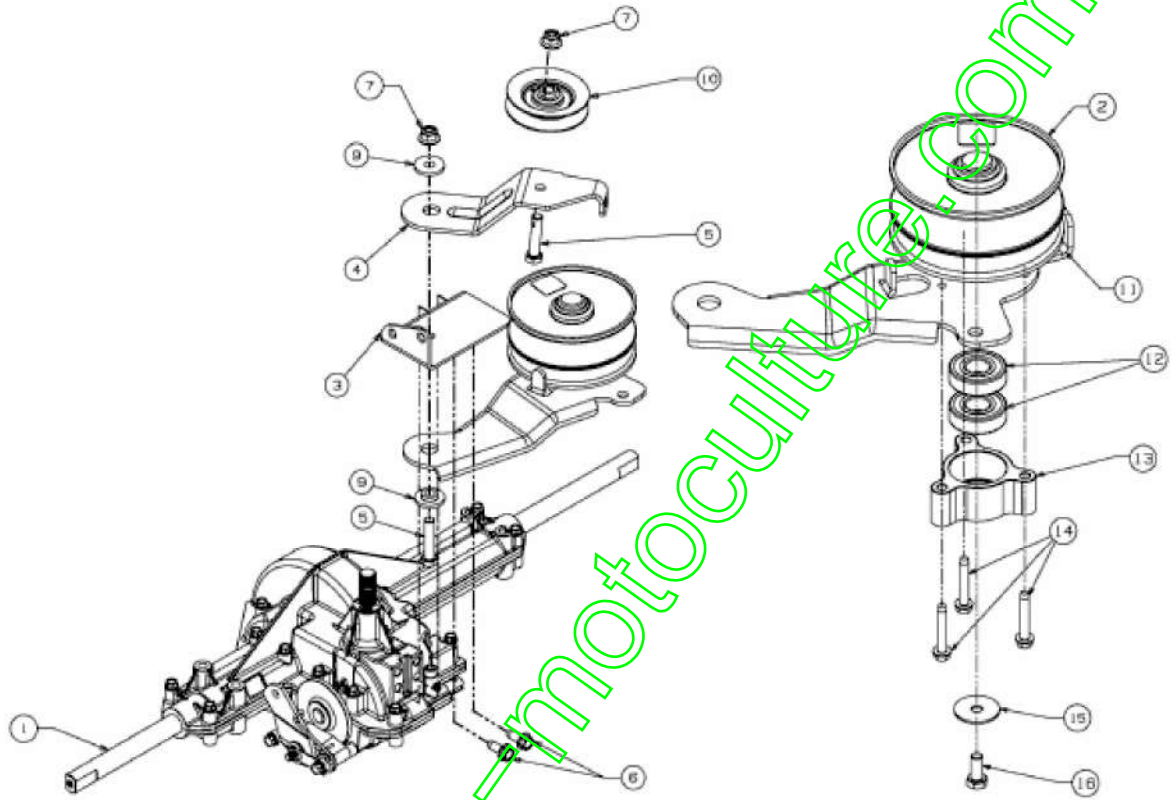

E3-06545B-02



Position	Numéro de pièce	Quantité	Désignation	Dimension
1	618-04566	1	PONT COMPLET	FINISH:
2	656-04015 A	1	POULIE VARIATEUR	FINISH:
3	683-04176 A	1	SUPPORT	SCHWARZ
4	683-04207	1	SUPPORT TENDEUR	SCHWARZ
5	710-0347	2	VIS HEX. 3/8-16:1.75:G R5:STD	FINISH:MTD STD 701-0100 0
6	710-1260A	2	VIS TT:5/16-18:.750 HX INDWSH	LAGERGEH.MESSERWEL LE:701-01002
7	712-04065	2	ÜCROU HEXAGONAL	FINISH:SPEC-101616 912- 04065
9	738-0347	2	RONDELLE ; EMB. .62 5IDx.169	FINISH:
10	756-04325	1	POULIE TENDEUR	FINISH:SCHWARZ LACKIE RT
11	683-04206	1	SUPPORT VARIATEU R LT-5	683-04206 SCHWARZ
12	741-0124A	2	ROULEMENT A BILLE	FINISH:
13	718-04261	1	CAGE DE ROULEMEN T	FINISH:ROTSCHUTZ SIE HE ZG.
14	710-0778	3	VIS HEX. TT:1/4-20:1.5 00	FINISH:MTD SPEC-701-010 02
15	736-0362	1	RONDELLE .320ID X 1. 25 ODX .0	FINISH:701-01001
16	710-0627	1	VIS HEX. 5/16-24:.750 GR5:LOCK	FINISH:MTD STD 701-0100 0

13CN761F686 (2012) > FREIN

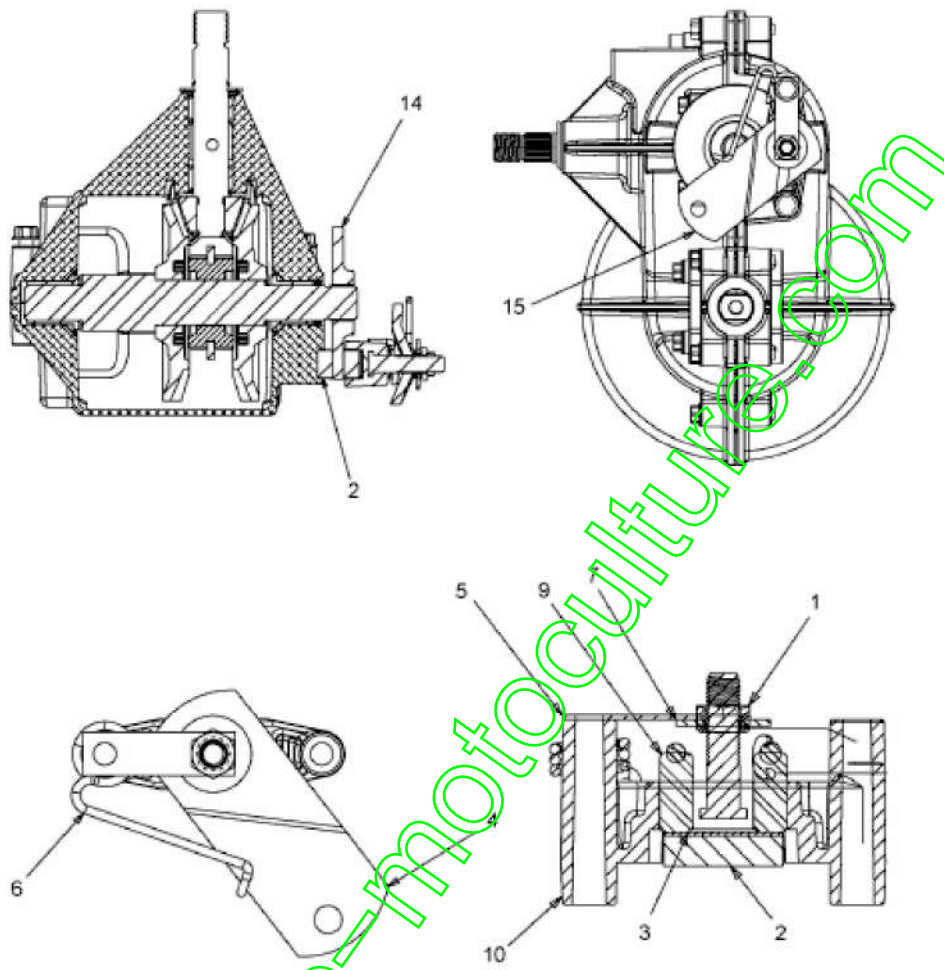

E3-06545B-03

Position	Numéro de pièce	Quantité	Désignation	Dimension
1	712-0273	1	ÜCROU HEXAGONAL 5/16-24"	FINISH:MTD STD 701-01000
2	717-0678	2	PLAQUETTE DE FREIN	FINISH:
3	717-0682	1	INSERT DE FREIN	FINISH:NONE 917-0682
4	717-0700	1	LEVIER DE FREIN, ; DROITE	717-0700
5	718-0150	1	LANG. DE SUPP.: ANTI ROTATION	FINISH:GELB VERZINKT
6	732-0742	1	RESSORT	732-0742/932-0742
7	736-0371	1	RONDELLE 1.344XA .875"	FINISH:701-01001
9	741-0343	2	GOUJON DE PRESSION 5/16"	FINISH:SIEHE ZG. 941-0343
10	761-0198A	1	APPUI DE FREIN	FINISH:NONE 961-0198A
14	761-0202	1	DISQUE DE FREIN	FINISH:ÖL UND FETT FREI
15	661-0001	1	FREIN	661-0001 / 961-0001

www.emc-motoculture.com

13CN761F686 (2012) > CONTROLE DE VITESSE

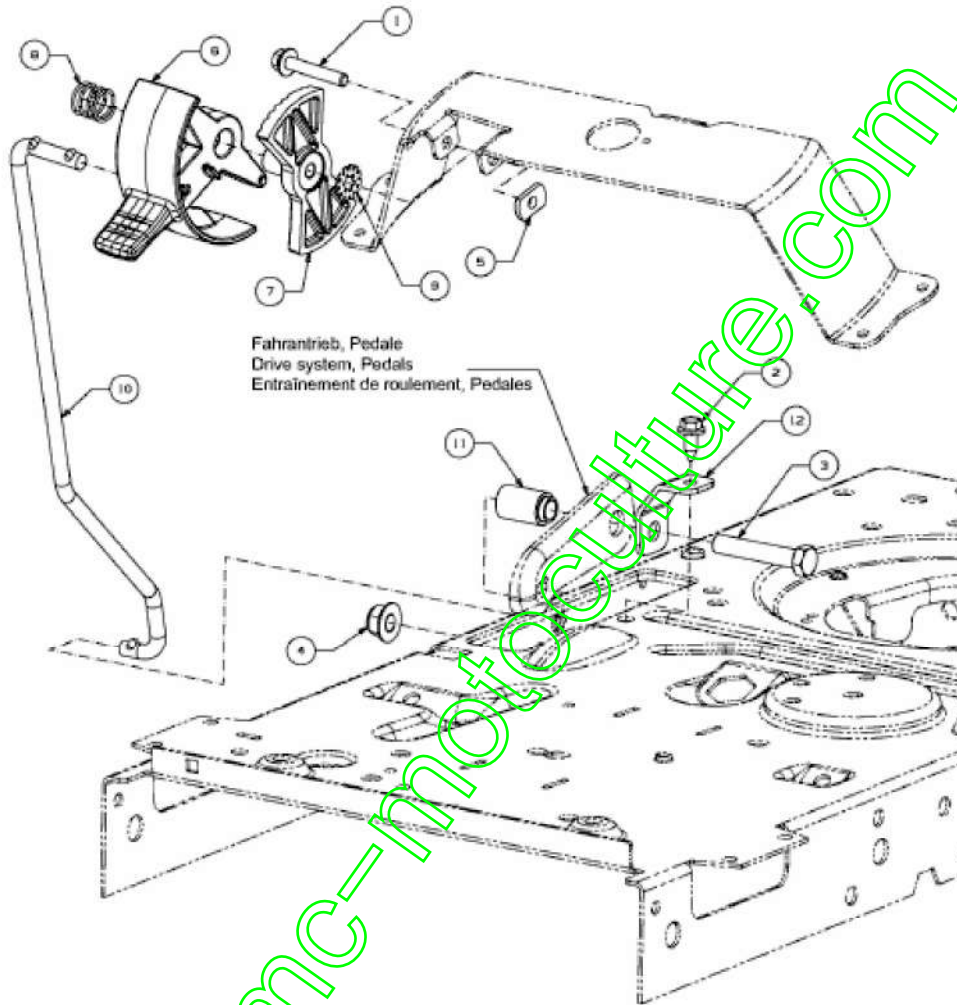

E3-07438A-01

Position	Numéro de pièce	Quantité	Désignation	Dimension
1	710-05237	1	VIS	FINISH:MTD STD 701-01000
2	710-1652	1	VIS HEX. TT:1/4-20:.625:HXINDW	FINISH:MTD-SPEC-701-01002
3	710-3144	1	VIS HEX.: 3/8-16:2.00:GR5:STD	FINISH:STD 701-01000 910-3144
4	712-04065	1	ÜCROU HEXAGONAL	FINISH:SPEC-101616 912-04065
5	712-0414	1	ÜCROU 1/4-20	FINISH:PLAIN
6	731-07885A	1	POIGNEE DE VITESSE	FARBE:KUNSTSTOFF GELB
7	731-07965	1	FINISH: PLAIN (SCHWARZ)	FINISH: PLAIN (SCHWARZ)
8	732-04877	1	RESSORT	FINISH:GELBVERZ:MTD 701-01000
9	736-3006	1	RONDELLE (1/4) X -75	FINISH:GELBVERZ:MTD 701-01001
10	747-05398	1	TRINGLE DE VITESSE	FINISH:701-01000 OR 701-01007
11	750-04465C	1	ENTRETOISE	FINISH:GEÖLT
12	783-06823	1	SUPPORT	KONTROLLHEBEL:VERZ. SIEHE ZG.

www.emc-motoculture.com

13CN761F686 (2012) > TABLEAU DE BORD PIÈCE INFÉRIURE

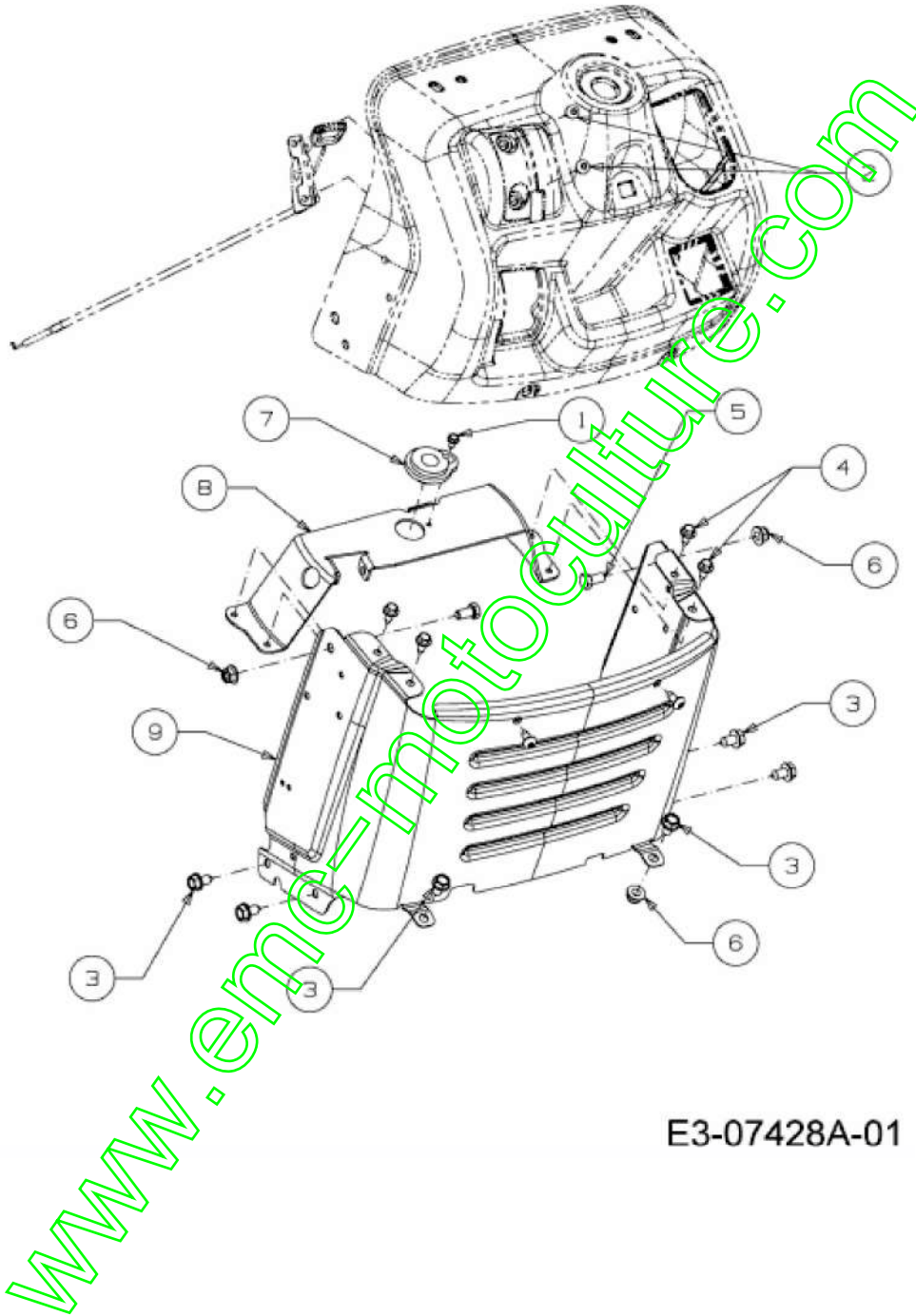

E3-07428A-01

Position	Numéro de pièce	Quantité	Désignation	Dimension
1	710-0224	1	VIS PARK:#10-16:0.500: HXINDWSH	FINISH:MTD STD 701-01 002
2	710-05070	4	VIS	FINISH:SCHWARZ SPEC 701-01010
3	710-0604A	6	VIS 5/16-18:0.625	FINISH:MTD-SPEC-701-0 1002
4	710-1652	4	VIS HEX. TT:1/4-20:.625: HXINDW	FINISH:MTD-SPEC-701- 01002
5	710-3025	2	VIS	FINISH:701-01000
6	712-04063	3	ÜCROU HEX. AVEC FLA NC	FINISH:MTD STD SPEC- 101616
7	741-0587	1	SUPPORT	FINISH:NATUR
8	783-06785 A	1		
9	783-06811	1		

www.emc-motoculture.com



13CN761F686 (2012) > ROUES ARRIÈRE 20X8 JUSQU'AU 30.06.2013

bis 30.06.2013  
to 30.06.2013  
jusqu'au 30.06.2013

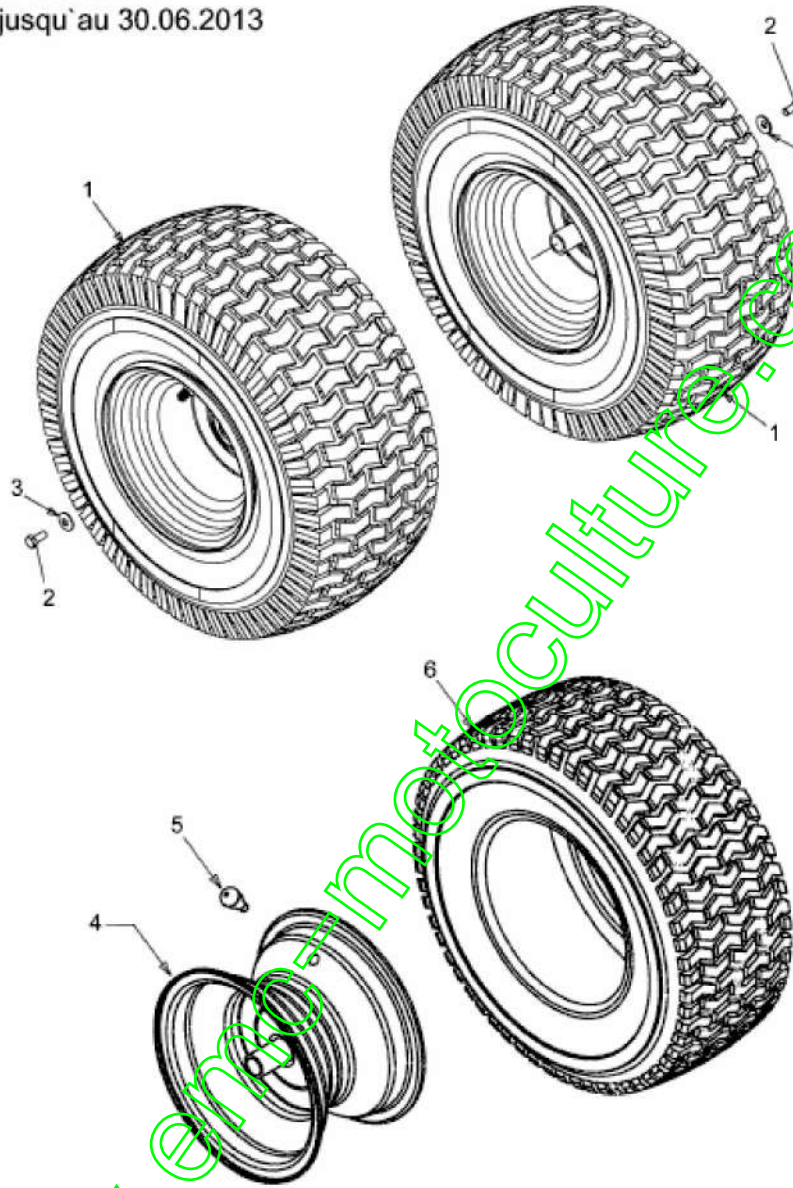

E3-03793A-01



Position	Numéro de pièce	Quantité	Désignation	Dimension
1	634-0104	2	ROUE COMPL 20" x 8" BEIGE	634-0104662/-G/-674/-Y/-CB/-WY
2	710-0627	2	VIS HEX. 5/16-24:.750 GR 5:LOCK	FINISH:MTD STD 701-01000
3	736-0242	2	RONDELLE CONIQUE.340 X.872X.060	FINISH:MTD STD 701-01001
4	634-04369	2	JANTE 8.0x7.0x .750 ID	FINISH:LACKIERT
5	734-0255	2	VALVE:PNEU	TR 412-P / 32.6mm / 934-0255
6	734-1596	2	PNEU 20 X 8.00.8 ST	BLOCK TURF PRO: RND SHL

www.emc-motoculture.com

13CN761F686 (2012) > ENCLICHEMENT PLATEAU DE COUPE, POULIE MOTEUR

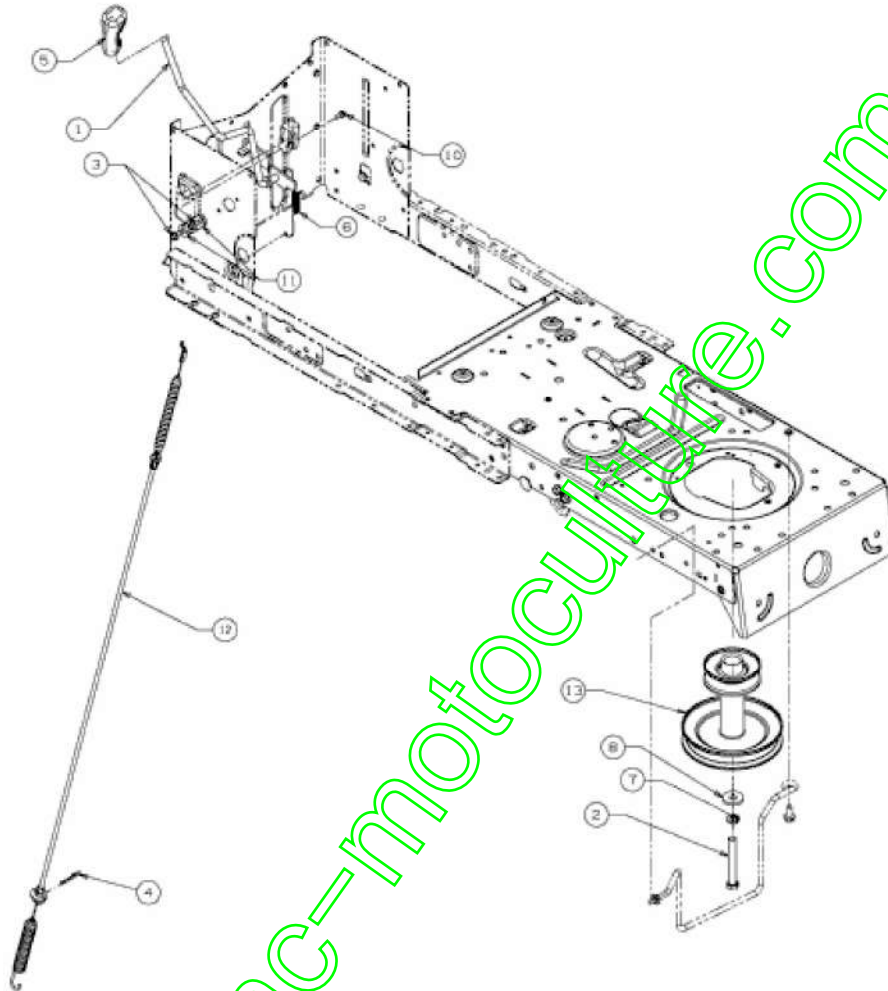

E3-05555B-01

Position	Numéro de pièce	Quantité	Désignation	Dimension
1	647-04096A-S	1	LEVIER EMBRAYAGE	SCHWEISSTEIL:FINISH LACKIERT
2	710-04608	1	VIS HEX. HHCS:7/16-20:3.25:GR5	FINISH:MTD SPEC-100015
3	710-0599	2	VIS ; SIX PANS CREUX	MTD SPEC:701-01002 or 101617
4	714-0145	1	GOUPILLE	FINISH:PHOS & OIL
5	720-04049A	1	POIGNEE PLASTIQUE	FINISH:SCHWARZ
6	732-04276A	1	RESSORT	FINISH:701-01006
7	736-0171	1	RONDELLE GROWER	FINISH:MTD STD 701-01001
8	736-0322	1	RONDELLE .450 X 1.250 X .164	FINISH:701-01001 936-0322
10	738-04237A	1	AXE EPAULE	FINISH:MTD STD 701-01002
11	741-04119A	2	SUPPORT PLASTIQUE	KUNSTSTOFF SCHWARZ
12	746-04173D	1	CABLE ENCLANCHEMENT LAMES LT5	ABGEDICHTET
13	756-04196A	1	POULIE MOTEUR	3.39 x 6.12 DIA: 701-01000

13CN761F686 (2012) > SUPPORT DE SIÈGE

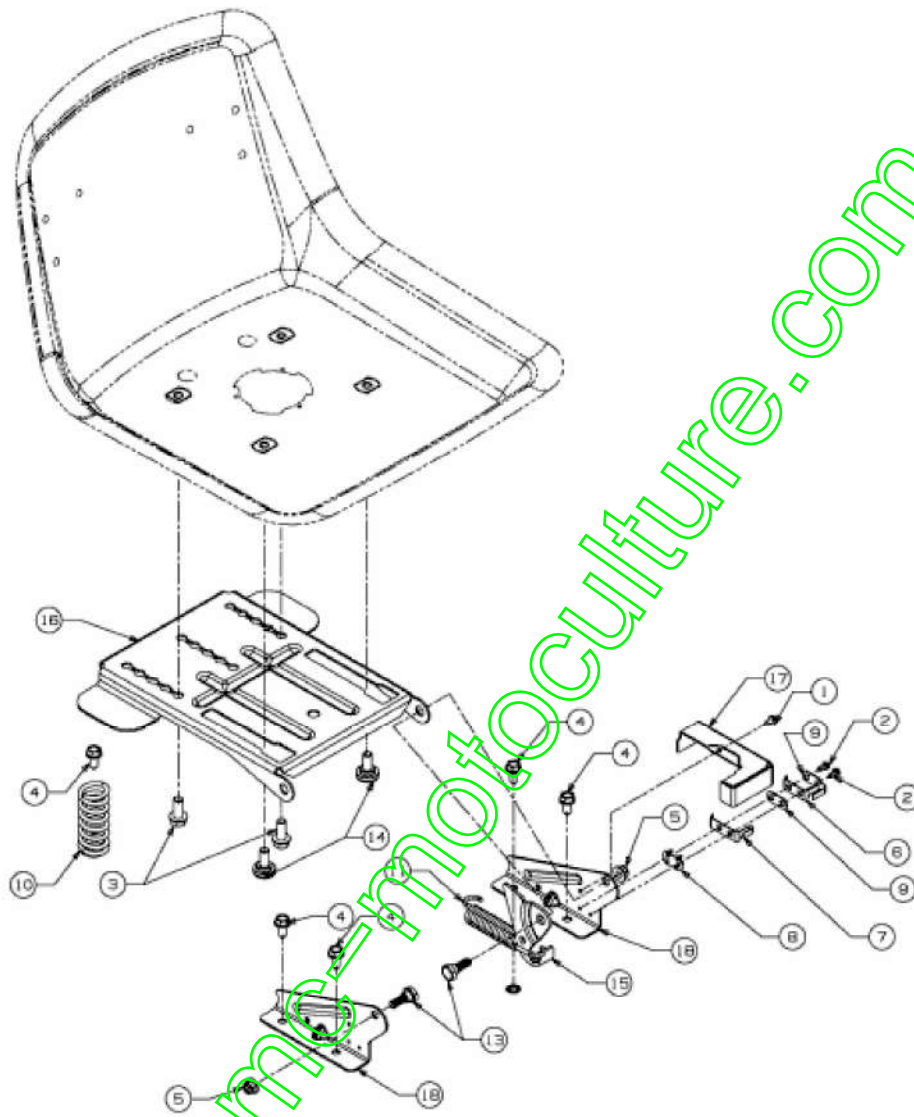

E3-04368B-01

Position	Numéro de pièce	Quantité	Désignation	Dimension
1	710-0224	1	VIS PARK:#10-16:0.500:HXINDWSH	FINISH:MTD STD 701-01002
2	710-0227	2	VIS	FINISH:MTD STD 701-01002
3	710-04482	2	VIS:3/8-16:.875:GR5:STD	FINISH:MTD STD 701-01000
4	710-04484	6	VIS HEX. TT:5/16-18:.750:HXIND	FINISH:MTD SPEC-701-01002
5	712-04063	2	ÜCROU HEX. AVEC FLANC	FINISH:MTD STD SPEC-101616
6	725-1303	1	RESSORT DE S@RETÜ SIEGE	SI.-SCHALTER SITZ:GELBVERZINKT
7	725-1439	1	RESSORT S@RETÜ DE SIEGE	SI.-SCHALTER SITZ:GELBVERZINKT
8	726-0278	1	PLAQUE D'ISOLATION	FINISH:NATUR ODER SCHWARZ
9	726-0279	2	PLAQUE D'ISOLATION	FINISH:NATUR ODER SCHWARZ
10	732-04035	2	RESSORT DE SIEGE	FINISH:701-01000
11	732-04309	1	RESSORT	FINISH:MTD STD 701-01006
12	736-0607	1	RONDELLE	FINISH:MTD STD 701-01001
13	738-0296	2	AXE EPAULE	FINISH:701-01000
14	738-04012 A	2	VIS EPAULEE	FINISH:SIEHE ZG.
15	783-0209D	1	SUPP. SIEGE	FINISH:VERZINKT SIEHE ZG.
16	783-04081 D	1	783-06352637	FINISH:LACKIERT MTD QUALITÄT
17	783-04877 A	1	783-06279	FINISH:LACKIERT
18	783-1489D	2	783-1489B-4015 / FEUE RROTQ	

13CN761F686 (2012) > AXE AVANT

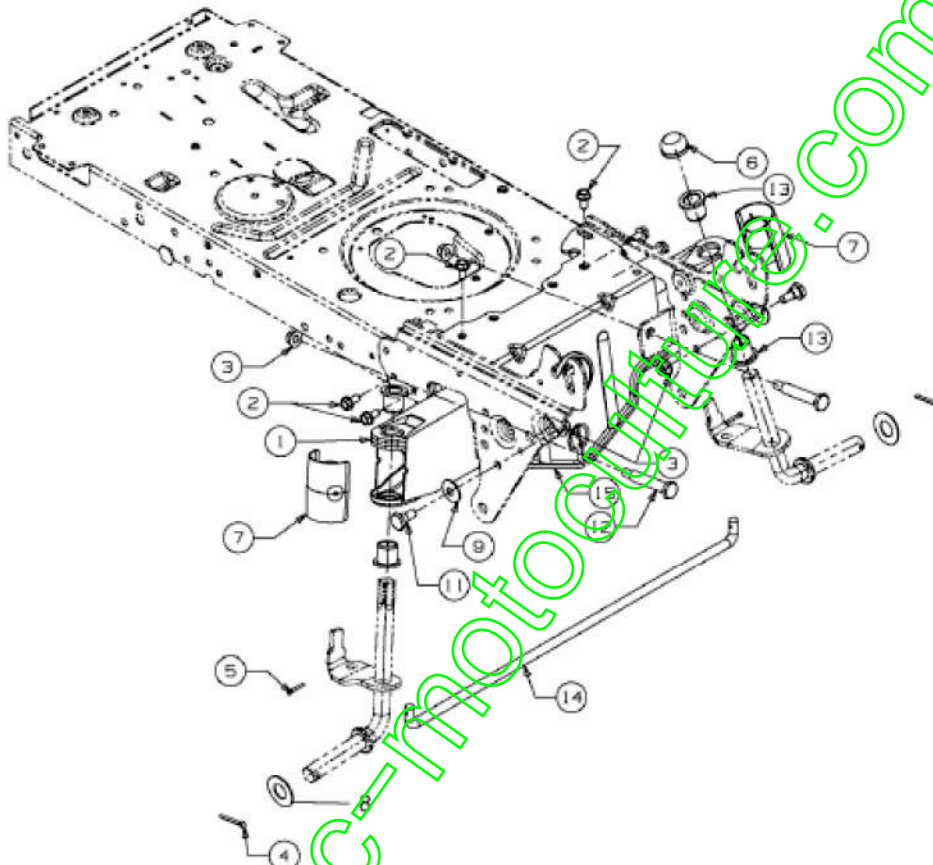

E3-04363B-01

Position	Numéro de pièce	Quantité	Désignation	Dimension
1	683-0128B	1	BLECH-VORDERACHSE VOLLST:	SCHWEISSTEIL: 683-0128B-0637
2	710-04484	6	VIS HEX. TT:5/16-18:.750:HXIND	FINISH:MTD SPEC-701-01002
3	712-04065	4	ÜCROU HEXAGONAL	FINISH:SPEC-101616 912-04065
4	714-0162	2	GOUPILLE FENDUE 5/32:1.25	FINISH:MTD SPEC-100015
5	714-0474	2	GOUPILLE	FINISH:MTD SPEC-100015
6	726-0341	1	CAPUCHON CLIPS	FINISH:SCHWARZ
7	731-1291A	2	CARTER PLASTIQUE	MATERIAL:PP SCHWARZ:LT5
8	736-0316	2	RONDELLE 1.78XA1.59"	FINISH:MTD STD 701-01000
9	736-0331	2	RONDELLE CONIQUE	FINISH:MTD SPEC-100016
11	738-0143	2	VIS EPAULEE	FINISH:MTD SPEC 100015 (EU)
12	738-04128	2	VIS EPAULEE .500x2.38:3/8-16	FINISH:MTD STD 701-01006
13	741-0660A	4	BAGUE	FINISH:KUNSTSTOFF SCHWARZ
14	747-04299A	1	TRINGLE DE DIRECTION	FINISH:MTD STD 701-01000
15	783-05326B	1	783-05326B-S	FINISH:LACKIERT MTD QUALITÄT

13CN761F686 (2012) > ACCESSOIRES MOTEUR

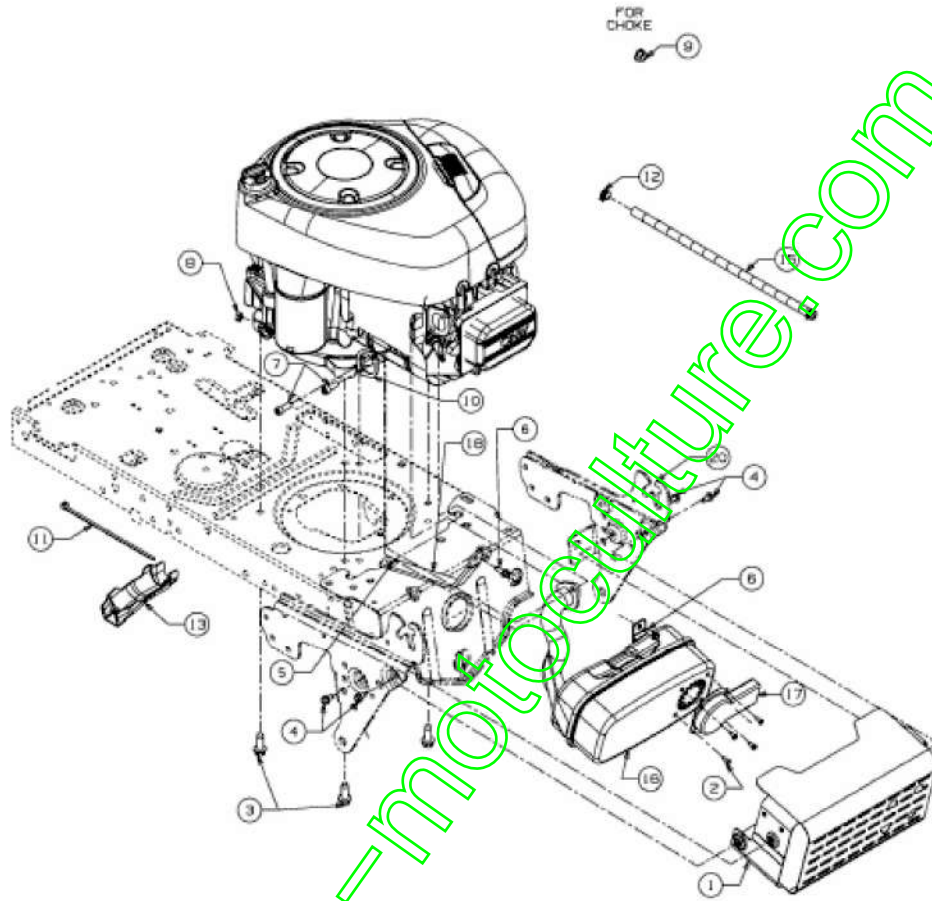

E3-04366D-01



Position	Numéro de pièce	Quantité	Désignation	Dimension
1	683-04549	1	PROTECTION D ECHAPPEMENT	SCHWEISSTEIL:FINISH LACKIERT
2	710-0227	4	VIS	FINISH:MTD STD 701-01002
3	710-04683	4	VIS HEX.:3/8-16:1.000	FINISH:MTD SPEC-701-01002
4	710-0599	4	VIS   SIX PANS CREUX	MTD SPEC-701-01002 or 101617
5	710-0604A	1	VIS 5/16-18:0.625	FINISH:MTD SPEC-701-01002
6	710-0642	2	VIS 1/4-20:0.750	MTD SPEC-701-01002 910-0642
7	710-1314A	2	VIS HEX. INT. 5/16-18:75:GR8	FINISH:PHOS & OIL
8	712-0271	1	ECROU 1/4-20" + DISQUE DENTÜ	FINISH:MTD STD 701-010015
9	712-3005	1	ÜCROU AVEC FLANC:3/8-16:GR5	FINISH:701-01000 912-3005
10	721-0208	1	JOINT ECHAP B/S MONO CYLINDRE	FINISH:B&S #272293
11	725-0157	1	COLLIER DE SERRAGE 3/16X0.5X7.4	MATERIAL:NYLON-SCHWARZ
12	726-0205	2	COLLIER DE SERRAGE DE BOYAU	FINISH:PHOSPHATIER T (GELB)
13	731-05628	1	GOUTIERE VIDANGE D HUILE	FINISH:SCHWARZ
15	751-0535	1	TUYAU ESSENCE NOIR	Ø12,7+/-5.84 / Ø6,35+/-0,41
16	751-10448 C	1	ECHAPPEMENT	FINISH:N/A
17	751-11053	1	DEFLECTEUR D ECHAPPEMENT	LANGER ABGASKANAL
18	783-06510	1	MODELL 31:FINISH LACKIERT *	MODELL 31:FINISH LACKIERT *

13CN761F686 (2012) > CAPOT DE MOTEUR 1-STYLE

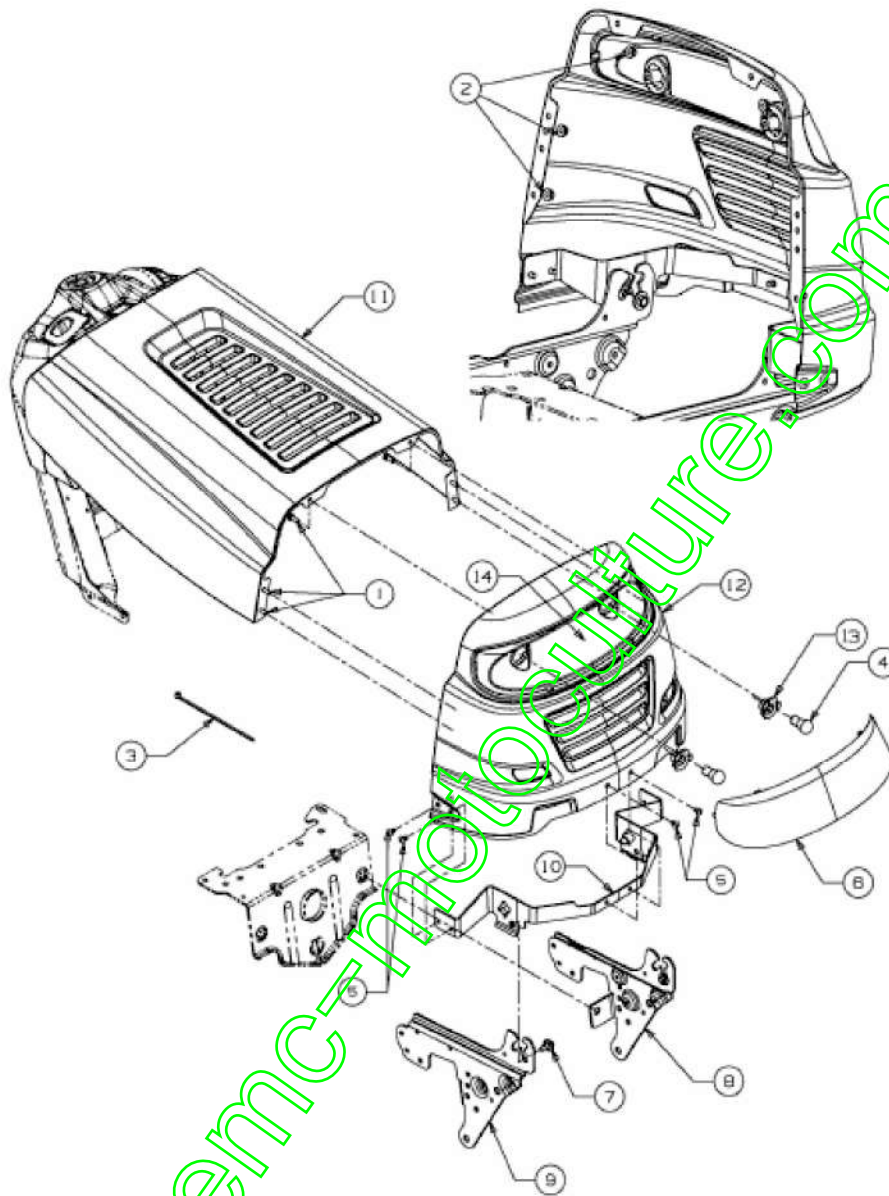

E3-07478A-01

Position	Numéro de pièce	Quantité	Désignation	Dimension
1	710-0751	6	VIS HEX.: 1/4-20:.620:GR 5:STD	FINISH:701-01000
2	712-04064	6	ÜCROU HEXAGONAL	GRF:FINISH:701-01000 912-04064
3	725-0157	1	COLLIER DE SERRAGE3/16X0.5X7.4	MATERIAL:NYLON-SCHWARZ
4	725-0963	2	AMPOULE ÜLECTRIQUE	12V 21W
5	728-04063	6	FINISH:	FINISH:
6	731-04949 A	1	OPTIQUE DE PHARE	FINISH:CLEAR
7	738-04091 A	2	VIS À ÉPAULE	FINISH:701-01002
8	783-05417	1	ÜTRIER DE CHARN.:j D R. CAPOT	FINISH:LACKIERT
9	783-05418	1	ÜTRIER DE CHARN.:j D R. CAPOT	FINISH:LACKIERT
10	783-05454	1	MTD NOIR	FINISH:LACKIERT MTD QUALITÄT
11	783-05684	1	PERLEISS	FINISH:LACKIERT MTD QUALITÄT
12	783-05685	1	CALANDRE VERTE VERT S LOISIRS	FINISH:LACKIERT MTD QUALITÄT
13	725-1649	2	DOUILLE DE LAMPE: 1/4 ROTATION	GRAU KUNSTSTOFF
14	777X41984	1	REFLECTEUR	FINISH:

13CN761F686 (2012) > SIÈGE

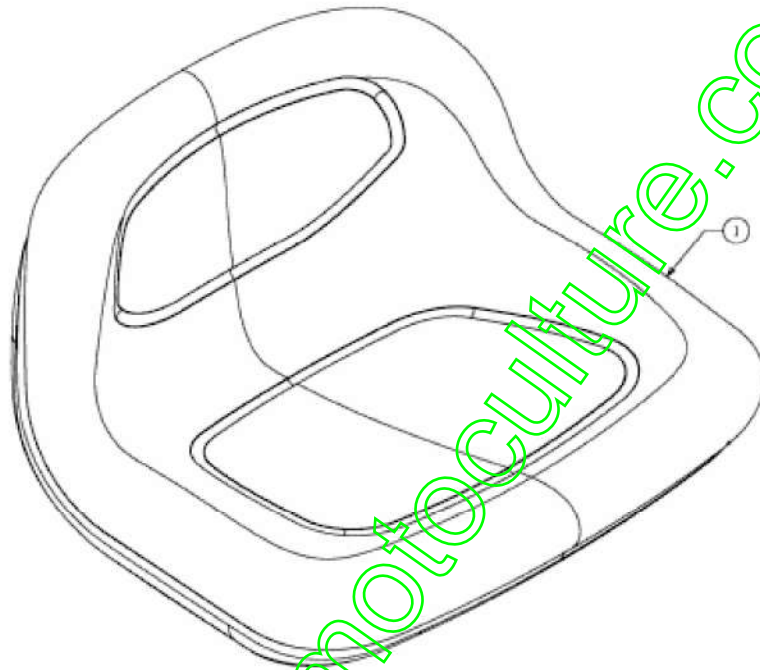

E3-06552A-01

Position	Numéro de pièce	Quantité	Désignation	Dimension
1	757-04111	1	SIEGE BAS	FINISH: SCHWARZ

[www.emc-motoculture.com](http://www.emc-motoculture.com)

13CN761F686 (2012) > PLAN ÉLECTRIQUE

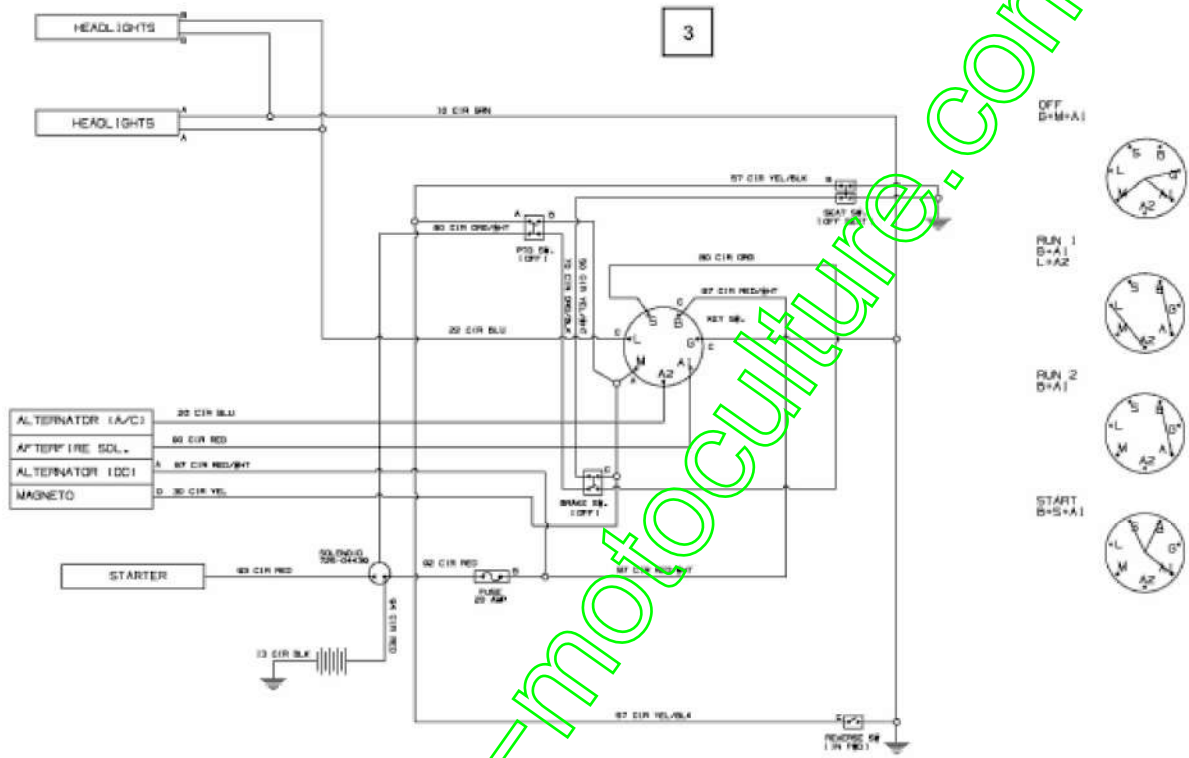

E3-02735F-02

Position	Numéro de pièce	Quantité	Désignation
3	725-04433F	1	FAISCEAU COMPLET

[www.emc-motoculture.com](http://www.emc-motoculture.com)