

Position	Numéro de pièce	#	Appellation I	Appellation II
1	17198A	1	PLAQUE	17198A
2	683-0002B637	1	TRAVERSE AVANT	MTD-SCHWARZ
3	710-0514	1	VIS HEX.:3/8-16:1.00:GR5:STD	FINISH:MTD SPEC-100015
4	710-0643	1	VIS HEX.: 5/16-18:1.00:GR5	FINISH:MTD SPEC-100015
5	710-0726	4	VIS 5/16-12:0.750:HXINDWS	FINISH:MTD STD 701-01002
6	710-0805	1	VIS HEX.:5/16-18:1.50:GR5:STD	FINISH:701-01000
7	710-1309	1	VIS	FINISH:MTD SPEC-100015
8	712-0240	1	ECROU HEX.: 7/16-20:GR2	FINISH:MTD SPEC-100015
9	712-0262	1	ECROU	FINISH:MTD SPEC-100015
10	712-0429	1	ECROU	FINISH:SPEC-100015
11	712-0431	3	ECROU STOP 3/8-16:GR5	FINISH:MTD SPEC-100015
12	712-3004A	2	ECROU HEX.: 5/16-18:GR5:SD:LK	FINISH:MTD SPEC-100015
13	714-0470	2	EPINGLE EX AF-43010	FINISH:SPEC-100015 470 32 32
14	717-1757A	1	SEGMENT DE DIRECTION	717-1757A
16	723-0448A	1	ROTULE DE DIRECTION 7/16-20	FINISH:MTD SPEC-100015
17	726-0214	1	BOUCHON	FINISH:SCHWARZ
18	731-04057A	2	PALIER DE GRAISSAGE	LT5:MATERIAL PP SCHWARZ
19	736-0187	1	RONDELLE .64X1.24X.06	FINISH:MTD SPEC-100016
20	736-0242	1	RONDELLE CONIQUE.340X.872X.060	FINISH:MTD SPEC-100016
21	736-0356	1	RONDELLE	FINISH:MTD STD 701-01001
23	738-0141	1	AXE	
24	738-0527	2	BOULON	738-0527
25	738-0919	1	ARBRE DE DIRECTION 21,57 LG	FINISH:SIEHE ZG.
26	741-0475	1	DOUILLE PLASTIQUE:.385 ID	NATUR ODER SCHWARZ 941-0475
27	741-0487C	4	BAGUE DE ROUE	FINISH:SCHWARZ
28	741-0656A	1	BAGUE	941-0656A
29	747-04008	1	TRINGLE DE DIRECTION	747-04008
30	747-1268B	1	TIGE DE DIRECTION	747-1268B
31	748-0389	1	BAGUE	FINISH:GEÖLT
32	748-04014B	1	BIELLETTE DE DIRECTION	948-04014B

Position	Numéro de lapièce	#	Appellation I	Appellation II
33	748-04020	1	ENTRETOISE	948-04020
34	750-0535	1	ENTRETOISE	FINISH:GEÖLT
35	783-0041D637	1	SUPPORT	783-0041D-0637 RP B!
36	683-04014	1	AXE DROIT	
37	683-04013	1	AXE GAUCHE	

www.emc-motoculture.com

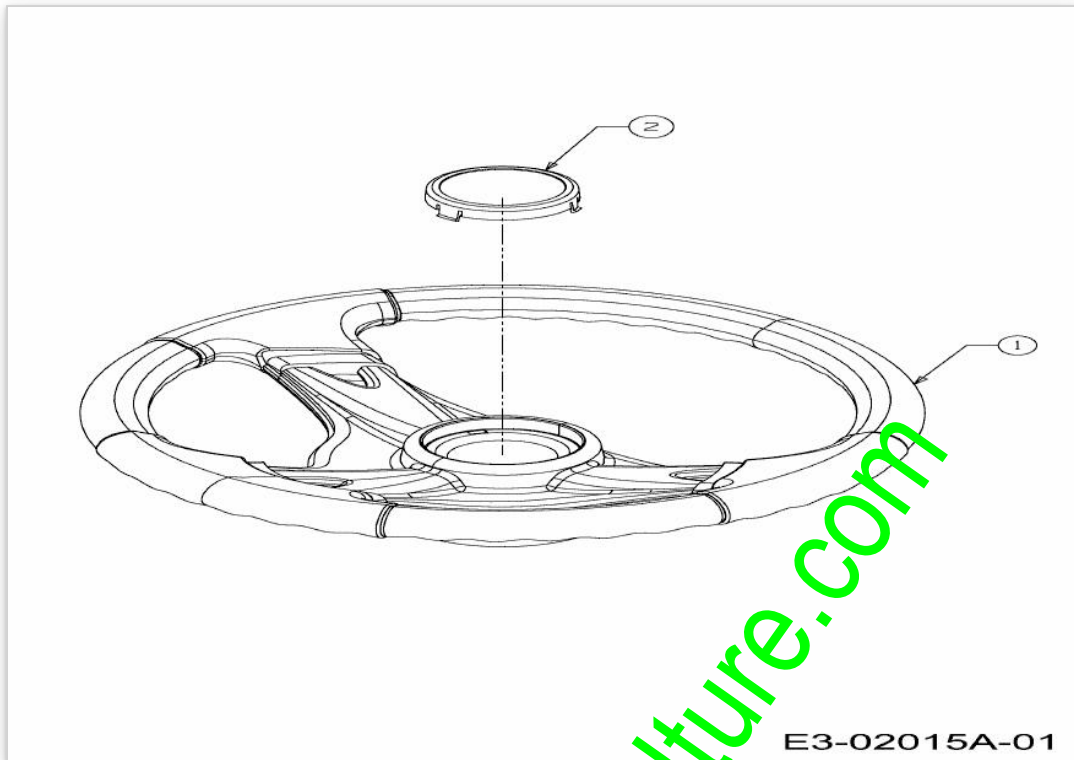

E3-02015A-01

www.emc-motoculture.com

Position	Numéro de lapièce	#	Appellation I	Appellation II
1	631-04028	1	VOLANT	FINISH SCHWARZ
2	731-04039	1	CAPUCHON DE VOLANT SANS LOGO	FINISH:KUNSTSTOFF SCHWARZ

www.emc-motoculture.com

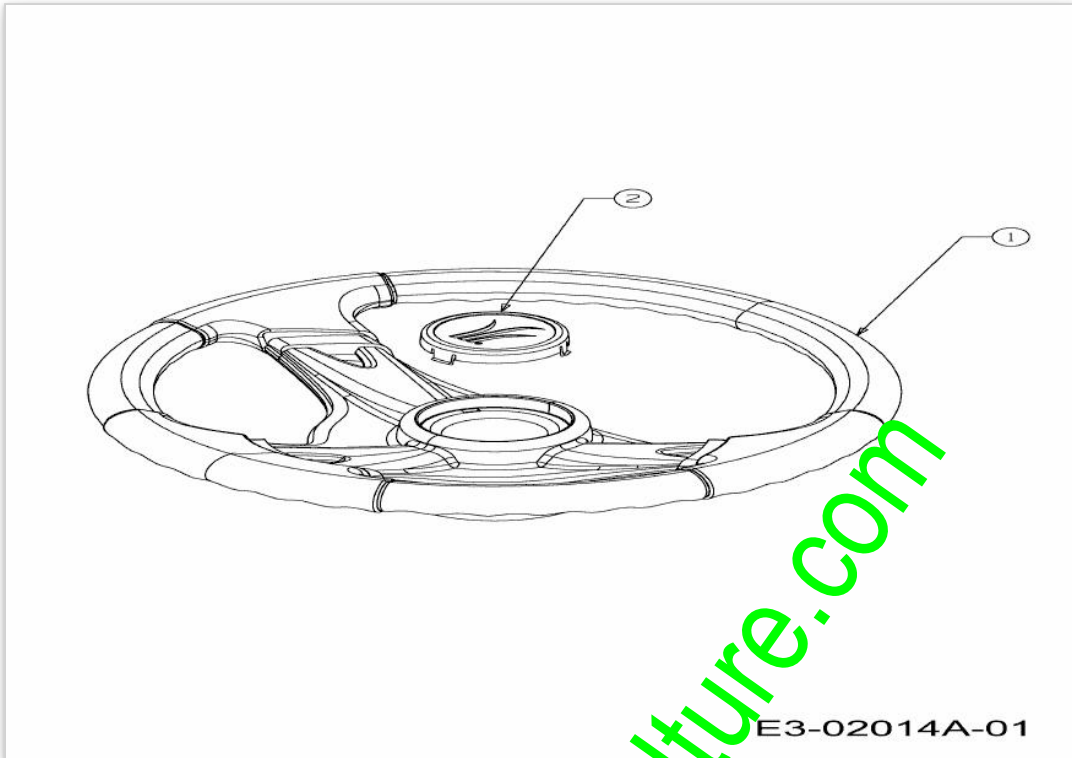

E3-02014A-01

www.emc-motoculture.com

Position	Numéro de lapièce	#	Appellation I	Appellation II
1	631-04028	1	VOLANT	FINISH SCHWARZ
2	731-04040	1	COUVERCLE DE VOLANT	Ò 60mm:KUNSTSTOFF SCHWARZ

www.emc-motoculture.com

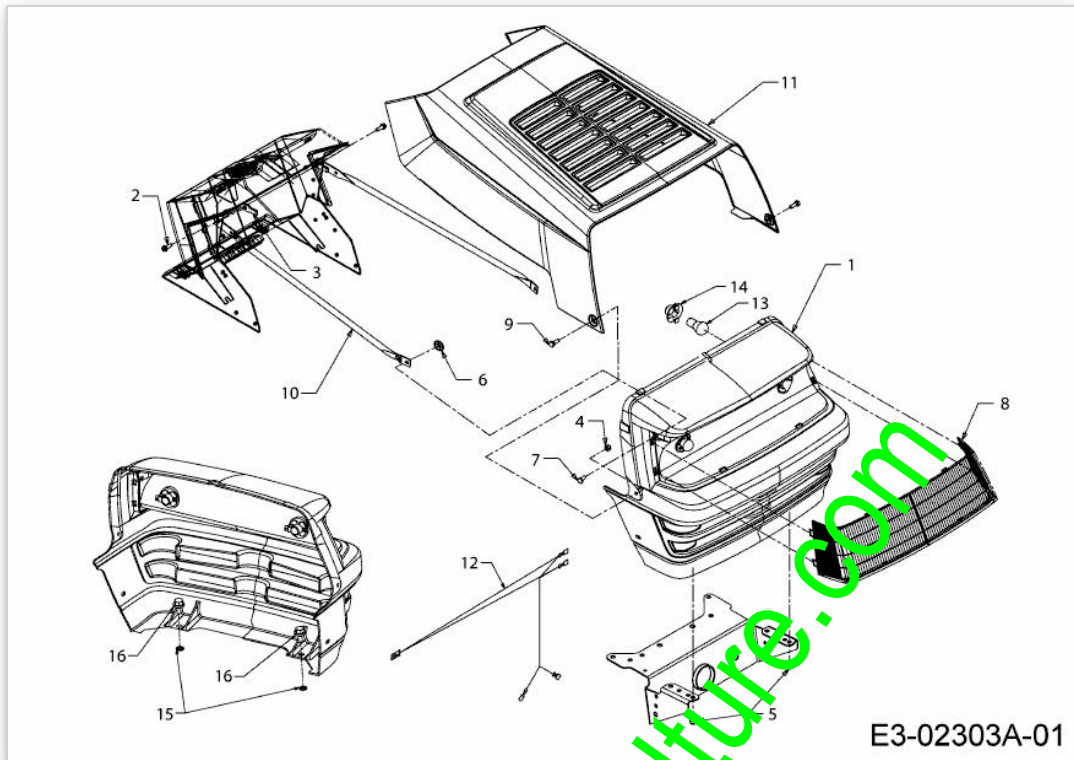

E3-02303A-01

Position	Numéro de pièce	#	Appellation I	Appellation II
1	731-1097F	1	CALANDRE PLASTIQUE	SCHWARZ / ACHTUNG: 631-04200
2	710-0642	2	VIS1/4-20:0.750	SPEC-100016 TYPE 1 910-0642
3	712-0185	2	ECROU EN TOLE	1/4-20:SPD U-TYPE
4	712-0324	2	ECROU HEX.:1/4-20:GR8:NYLON	FINISH:701-01000
5	712-0429	2	ECROU	FINISH:SPEC-100015
6	726-04012	2	CLIPS	FINISH:ASTM F1137 GRADE D
7	728-0162	2	RIVET	FINISH:PHOS & OIL
8	731-1099A	1	OPTIQUE DE PHARE	w/o ICON
9	738-0952A	2	VIS .375x.125:1/4-20	FINISH:MTD SPEC-100015
10	749-0722C	2	749-0722C-0637	749-0722C-0637
11	783-0250A	1	MOTORHAUBE	783-0250A
12	629-0469B	1	FAISCEAU DE PHARE	
13	725-0963	2	AMPOULE ELECTRIQUE	FINISH:
14	725-1649	2	DOUILLE DE LAMPE: 1/4 ROTATION	GRAU KUNSTSTOFF
15	726-0201	2	RONDELLE .3125 ID	MECHANISCH VERZINKT:SIEHE ZG.
16	738-04015	2	AXE	FINISH:PHOS&OIL 938-04015

www.emc-motoculture.com

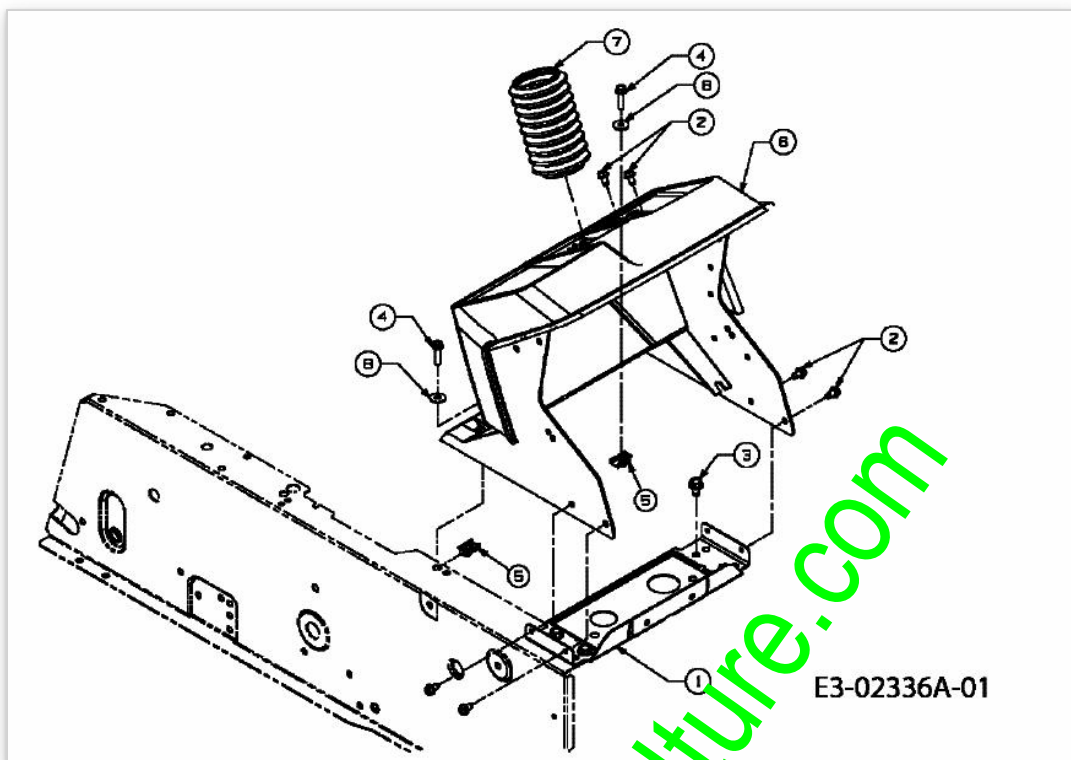

www.emc-motoculture.com

Position	Numéro de pièce	#	Appellation I	Appellation II
1	17632D	1	SUPPORT BATTERIE	17632D-0637
2	710-0599	6	VIS A SIX PANS CREUX	FINISH:MTD SPEC-101617
3	710-0607	4	VIS HEX.TT5/16-18:.500HXINDWSh	FINISH:MTD SPEC-100016 TYPE 1
4	710-0788	2	VIS A SIX PANS CREUX	FINISH:MTD SPEC-100016 TYPE 1
5	726-3054	2	ECROU	FARBE:METALLIC GRAY
6	731-04082	1	TABLEAU DE BORD	931-04082
7	731-0954	1	SOUFFLET GOMMEUX	731-0954
8	736-3090	2	RONDELLE 260 X .720 X .060	FINISH:MTD SPEC-100015

www.emc-motoculture.com

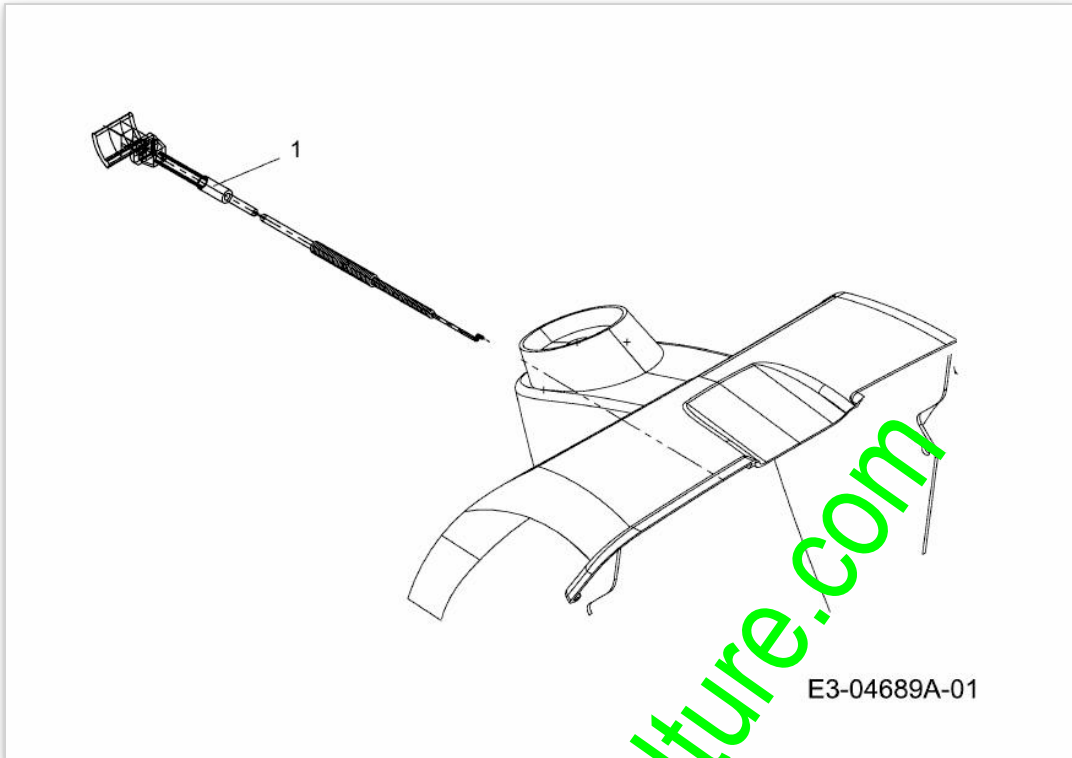

E3-04689A-01

www.emc-motoculture.com

Position	Numéro de lapièce	#	Appellation I	Appellation II
1	746-0614A	1	CABLE STARTER 96.5CM	746-0614A

www.emc-motoculture.com

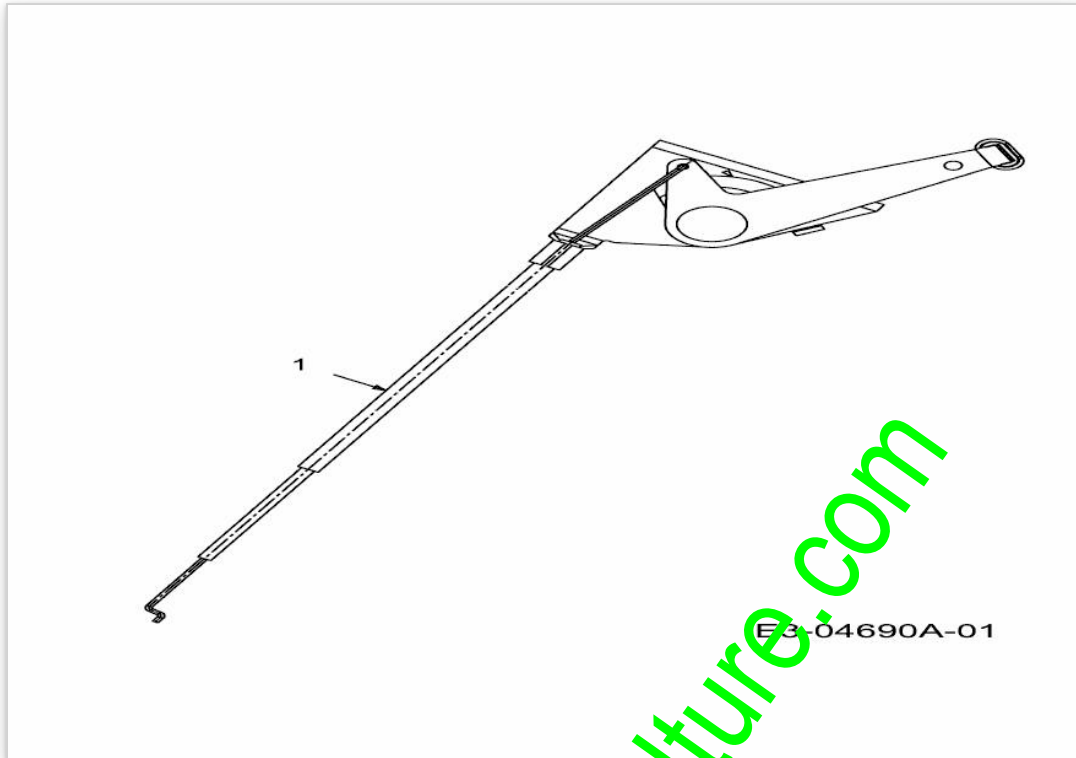

www.emc-motoculture.com

Position	Numéro de lapièce	#	Appellation I	Appellation II
1	746-04023B	1	CABLE A GAZ	746-04023B

www.emc-motoculture.com

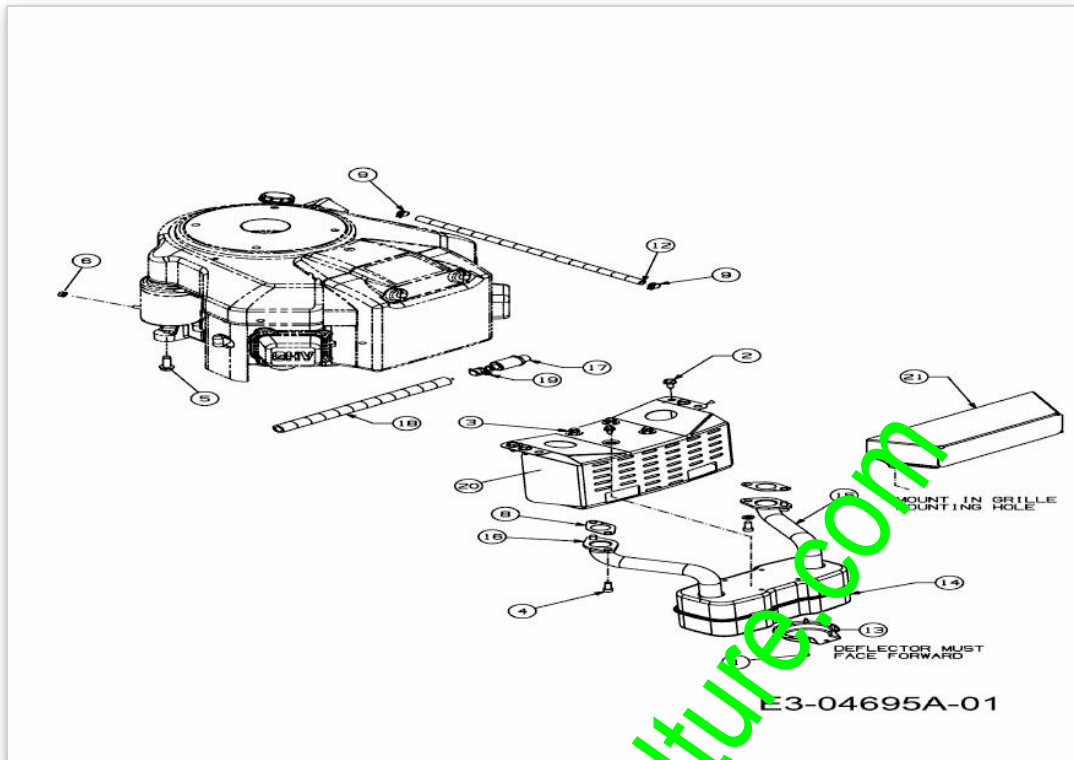

www.emc-motoculture.com

Position	Numéro de pièce	#	Appellation I	Appellation II
1	710-0227	4	VIS	FINISH:MTD SPEC-100016 TYPE 1
2	710-0726	4	VIS 5/16-12:0.750:HXINDWS	FINISH:MTD STD 701-01002
3	710-0896	4	VIS HEX.:1/4-14:0,625	FINISH:MTD STD 701-01002
4	710-1314A	4	VIS HEX. INT. 5/16-18:.75:GR8	FINISH: GM4435M CODE A
5	710-1315	4	VIS HEX.TT:3/8-16:1.25:HXIN:S	FINISH:SPEC-100016 TYPE 1
6	712-0271	1	ECROU 1/4-20"+ DISQUE DENTE	FINISH:MTD SPEC-100016 GR5
8	721-0460	2	JOINT D'ECHAPPEMENT INTEK TWIN	B&S P273485
9	726-0205	2	COLLIER DE SERRAGE DE BOYAU	FINISH:PHOS UND GELB LACKIERT
10	736-0119	1	RONDELLE	FINISH:MTD SPEC-100016
12	751-0535	1	TUYAU ESSENCE NOIR	Ø12,7+/-5.84 / Ø6,35+/-0,41
13	751-0564B	1	DEFLECTEUR ECHAPPEMENT	MATERIAL:ALUMINIERTER STAHL
14	751-0616A	1	POT D'ÜCHAPPEMENT	
15	751-0813A	1	TUYAU D'ÜCHAPPEMENT GAUCHE	
16	751-0814A	1	COUDE D'ÜCHAPPEMENT DROIT	
17	751-3140	1	EMBOUT DE VIDANGE	FINISH:SIEHE ZG. 951-3140
18	751-3141	1	TUYAU VIDANGE	13 X 3:FINISH KLAR METERWARE
19	751-3142	1	BOUCHON VIDANGE	FINISH:GELB 951-3142
20	783-0615C	1	HITZESCHUTZ FÜR AUSPUFF	SCHWARZ
21	783-0625C	1	PROTECTION	600:FINISH PLAIN

www.emc-motoculture.com

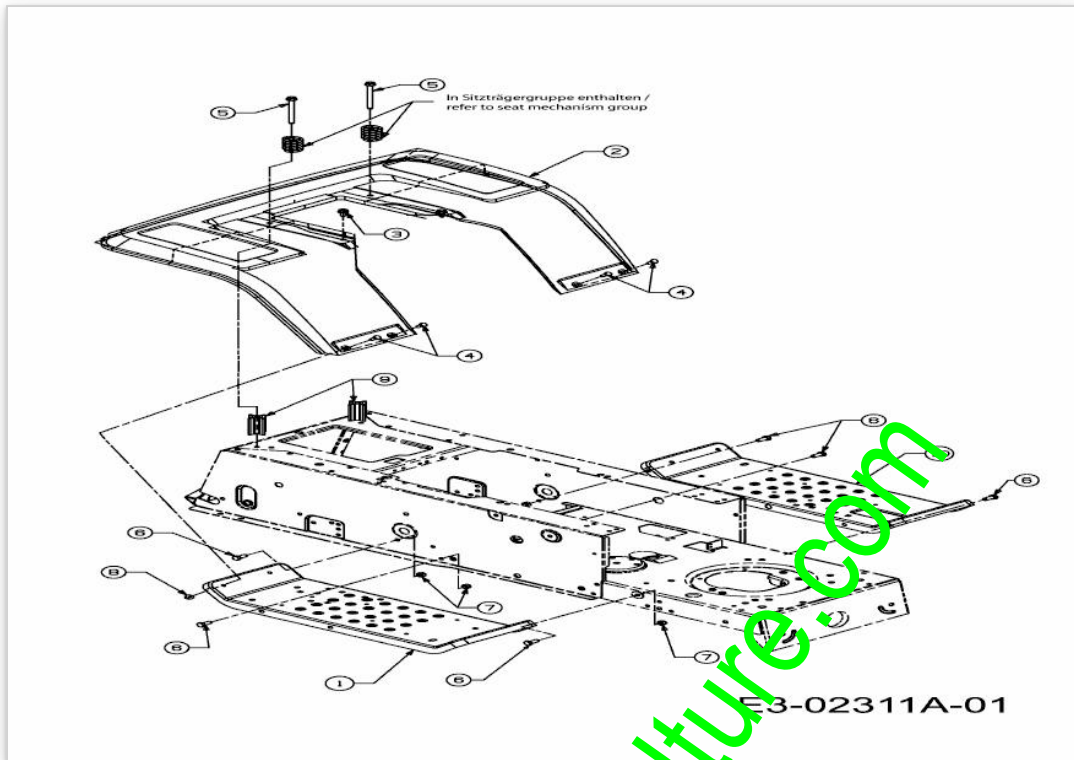

www.emc-motoculture.com

Position	Numéro de pièce	#	Appellation I	Appellation II
1	17770G	1	TRITTBLECH	17770G-0638
2	17870C	1		
3	710-0726	2	VIS 5/16-12:0.750:HXINDWS	FINISH:MTD STD 701-01002
4	710-0751	4	VIS HEX.: 1/4-20:.620:GR5:STD	FINISH:SPEC-100015
5	710-1208	2	VIS HEX.TT5/16-18:3.500	FINISH:MTD SPEC-701-01002
6	710-3008	6	VIS 5/16-18:.75:GR5:STD	SPEC-701-01006 or.SPEC-100015
7	712-0429	6	ECROU	FINISH:SPEC-100015
8	712-3027	4	ECROU HEXAGONAL 1/4-20:GRF	FINISH:MTD SPEC-100015
9	750-04212	2	ENTRETOISE	
10	783-04139A	1		

www.emc-motoculture.com

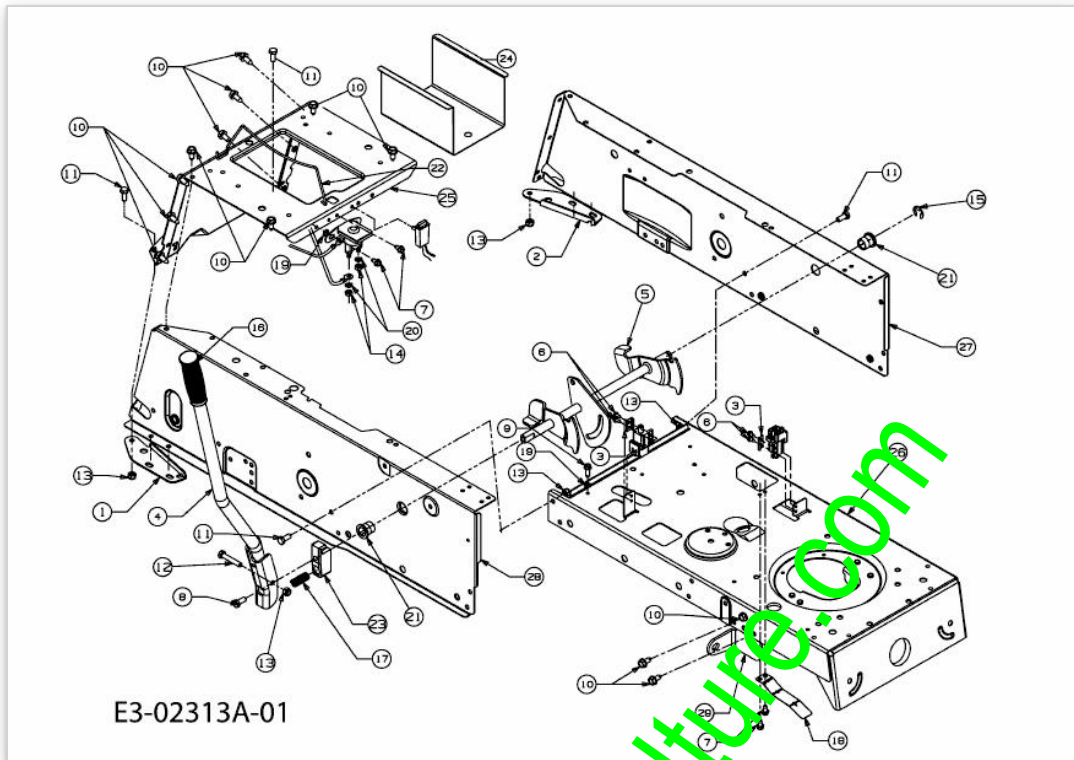

Position	Numéro de pièce	#	Appellation I	Appellation II
1	17668A	1	SUPPORT D'AXE DROIT	17668A-0637
2	17669A	1	SUPPORT D'AXE GAUCHE	17669A-0637
3	17962	2	PLAQUE DE SUPP. P. COMMUTATEUR	FINISH:WIE GESTANZT
4	683-04025	1	HEBEL-AUSHEBUNG	683-04025
5	683-04049A	1	ARBRE DE RELEVAGE	683-04049A-0637
6	710-0224	4	VIS PARK:#10-16:0.500:HXINDWSH	FINISH:MTD SPEC-100016 TYPE 1
7	710-0599	4	VIS A SIX PANS CREUX	FINISH:MTD SPEC-101617
8	710-0627	1	VIS HEX. 5/16-24:0.750 GR5:LOCK	FINISH:MTD SPEC-100015
9	710-0642	1	VIS 1/4-20:0.750	SPEC-100016 TYPE 1 910-0642
10	710-0726	13	VIS 5/16-12:0.750:HXINDWS	FINISH:MTD STD 701-01002
11	710-3008	4	VIS 5/16-18:0.75:GR5:STD	SPEC-701-01006 or.SPEC-100015
12	710-3180	1	VIS HEX. 5/16-18:1.75:GR5:STD	FINISH:SPEC-100015
13	712-0429	5	ECROU	FINISH:SPEC-100015
14	712-3006	2	ECROU HEXAGONAL	FINISH:SPEC-100015
15	716-0106A	1	CIRCLIPS	FINISH:PHOSPHATIERT
16	720-0233	1	POIGNEE	720-0233
17	732-0369	1	RESSORT DE PRESSION	MTD SPEC-100015 932-0369
18	732-0750A	1	LAMELLE: SÜCURITÜ DE BAC	FINISH:SIEHE ZG.
19	736-0222	2	RONDELLE	FINISH:MTD SPEC-100016
20	736-0329	2	RONDELLE GROWER	FINISH:SPEC-100016 24.8195.16
21	741-0487C	2	BAGUE DE ROUE	FINISH:Schwarz
22	747-04031	1	TRINGLE MAINTIEN DE BATTERIE	747-04031
23	748-04011A	1	SUPPORT DE LEVIER	748-04011A / 948-04011A
24	783-0345	1	SUPPORT DE BATTERIE	783-0345-0637
25	783-0355A	1	CHASSIS PLAQUE	783-0355A-0665
26	783-04011A	1	RAHMEN VORDERTEIL	783-04011A
27	783-04031A	1	RAHMENTEIL LINKS	783-04031A
28	783-04032	1	RAHMENTEIL RECHTS	783-04032
29	783-04213	1	SUPPORT	783-04213-0637

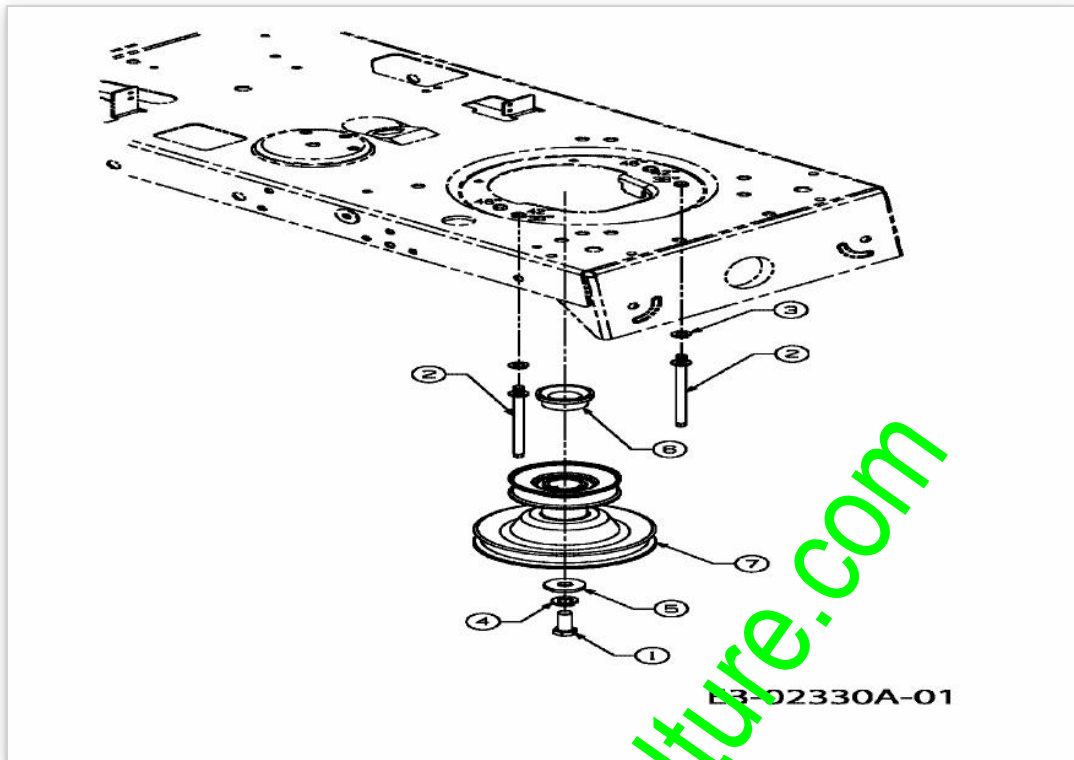

www.emc-motoculture.com

Position	Numéro de lapièce	#	Appellation I	Appellation II
1	710-3029	1	VIS	FINISH:701-01000
2	711-1044	2	BOULON	5/16-18X4.6 /911-1044
3	736-0119	2	RONDELLE	FINISH:MTD SPEC-100016
4	736-0171	1	RONDELLE GROWER	FINISH:MTD SPEC-100016
5	736-0322	1	RONDELLE .450 X 1.250 X .164	FINISH:SPEC-100016 936-0322
6	750-0956	1	ENTRETOISE	FINISH:PLAIN
7	756-04023	1	POULIE MOTEUR	756-04023 / 956-04023

www.emc-motoculture.com

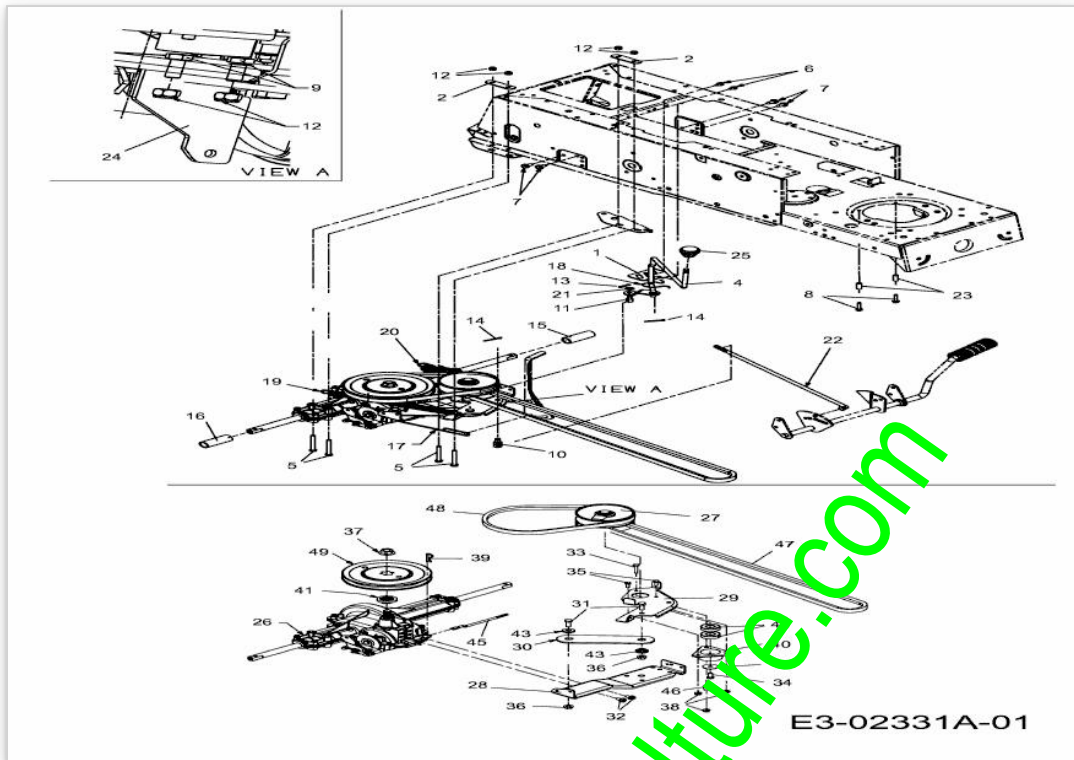

Position	Numéro de pièce	#	Appellation I	Appellation II
1	17630A	1	SUPPORT NOIR	17630A-0637 RP 17630-0637
2	17840	2	SUPPORT	FINISH: 17840-Z
4	647-04009B	1	SCHALTHEBEL VOLLST.	647-04009B
5	710-0176	4	VIS HEX.:5/16-18:2.75:GR5:STD	(21.1441.82)FINISH:SPEC-100015
6	710-0599	2	VIS A SIX PANS CREUX	FINISH:MTD SPEC-101617
7	710-0726	4	VIS 5/16-12:0.750:HXINDWS	FINISH:MTD STD 701-01002
8	710-0809	2	VIS HEX. TT:1/4-20:1.250:HXIND	FINISH:MTD SPEC-100016 TYPE 1
9	710-3008	2	VIS 5/16-18:.75:GR5:STD	SPEC-101-01006 or.SPEC-100015
10	711-04075A	1	EMBOUT	FINISH:MTD SPEC-100015
11	711-0736	1	AXE	FINISH:MTD SPEC-100015
12	712-0429	6	ECROU	FINISH:SPEC-100015
13	714-0104	1	GOUPILLE	FINISH:PHOS AND OIL
14	714-0470	2	EPINGLE EX AF-43010	FINISH:SPEC-100015 470 32 32
15	731-04602	1	ENTRETOISE	FINISH:PP SCHWARZ
16	731-04604	1	ENTRETOISE	FINISH:PP SCHWARZ
17	732-04029	1	RESSORT	732-04029 / 932-04029
18	732-04067	1	CLIP	732-04067 / 932-04067
19	732-04075B	1	ZUGFEDER	
20	732-04076A	1	RESSORT	FINISH:701-01000
21	736-0275	1	RONDELLE	FINISH:MTD SPEC-100015
22	747-04043	1	SCHALTSTANGE	747-04043
23	750-0566A	2	ENTRETOISE	FINISH:MTD SPEC-100015
24	783-04547	1	WALTERUNG DECK	783-04547-0637
25	720-0232	1	BOUTON DE LEVIER MANUEL	FINISH:KUNSTSTOFF SCHWARZ
26	618-04034	1	TRANSMISSION 1 VITESSE	618-04034 / 918-04034
27	656-04015A	1	POULIE VARIATEUR	FINISH:
28	683-04055A	1	QUERTRVERSE	683-04055A
29	683-04056	1	SUPPORT VARIATEUR	683-04056
30	683-04057	1	SUPPORT VARIATEUR	683-04057
31	710-0514	2	VIS HEX.:3/8-16:1.00:GR5:STD	FINISH:MTD SPEC-100015
32	710-0604A	2	VIS 5/16-18:0.625	FINISH:MTD SPEC-100016 TYPE 1
33	710-0606	1	VIS A SIX PANS CREUX	FINISH:SPEC-100015

Position	Numéro de pièce	#	Appellation I	Appellation II
34	710-0627	1	VIS HEX. 5/16-24:.750 GR5:LOCK	FINISH:MTD SPEC-100015
35	710-3015	2	VIS:1/4-20:.75:GR5:STD	FINISH:MTD SPEC-100015
36	712-0431	2	ECROU STOP 3/8-16:GRF	FINISH:MTD SPEC-100015
37	712-0700	1	ECROU HEXAGONAL	SPEC-100015+WAX 912-0700
38	712-3027	3	ECROU HEXAGONAL 1/4- 20:GRF	FINISH:MTD SPEC-100015
39	714-0209	1	GOUPILLE FENDUE	FINISH:SPEC 701-01006 914-0209
40	718-04012	1	CAGE DE PALIER	FINISH:ROSTSCHUTZ
41	718-04407	1	MOYEU: POULIE:5/8 DENTELURE	VERZÄHNRING
42	736-0362	1	RONDELLE .320ID X 1.25 ODX .0	FINISH:SPEC-100016
43	738-0372B	2	RONDELLE EPAULEE	FINISH:GEÖLT
44	741-0600	2	ROULEMENT ; BILLES	741-0600/941-0600
45	747-04072	1	SCHALTSTANGE	747-04072
46	750-04099	1	ENTRETOISE	750-04099 / 950-04099
47	754-04001A	1	COURROIE TRANSMISSION	954-04001A
48	754-04002	1	COURROIE	954-04002
49	756-04002	1	POULIE DE PONT	FINISH:SIEHE ZG. 956-04002

www.emc-motoculture.com

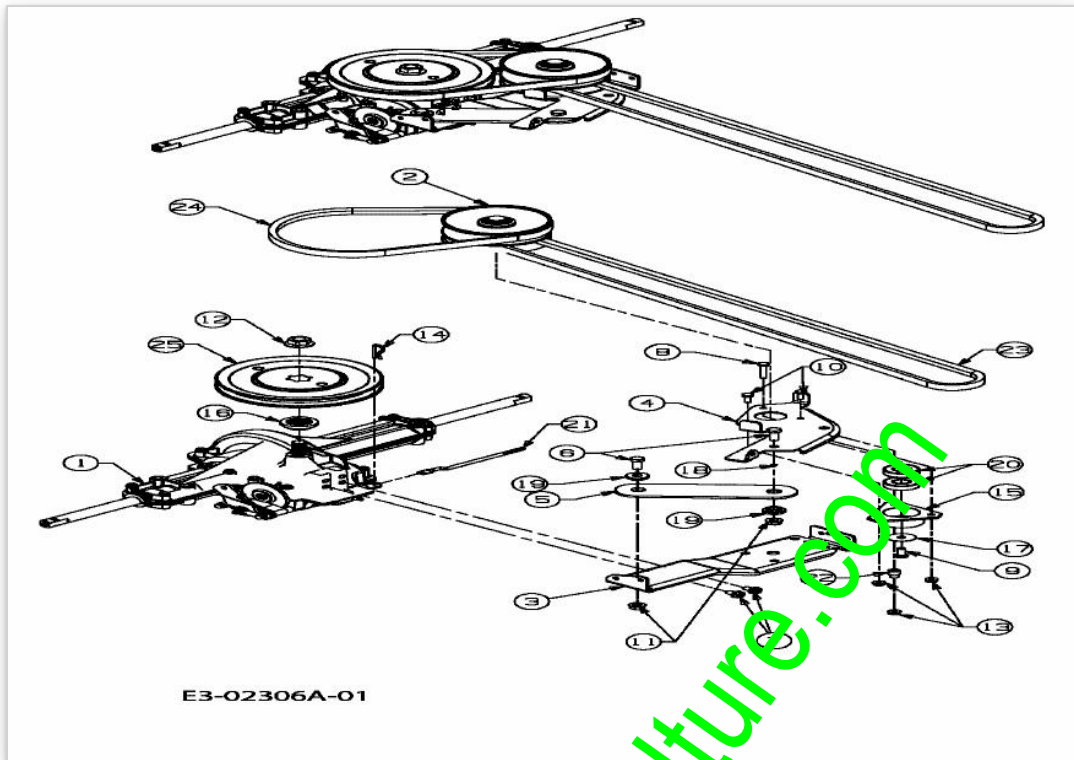

www.emc-motoculture.com

Position	Numéro de pièce	#	Appellation I	Appellation II
1	618-04034	1	TRANSMISSION 1 VITESSE	618-04034 / 918-04034
2	656-04015	1	POULIE DE VARIATEUR	4.75 OD
3	683-04055A	1	QUERTRVERSE	683-04055A
4	683-04056	1	SUPPORT VARIATEUR	683-04056
5	683-04057	1	SUPPORT VARIATEUR	683-04057
6	710-0514	2	VIS HEX.:3/8-16:1.00:GR5:STD	FINISH:MTD SPEC-100015
7	710-0604A	2	VIS 5/16-18:0.625	FINISH:MTD SPEC-100016 TYPE 1
8	710-0606	1	VIS A SIX PANS CREUX	FINISH:SPEC-100015
9	710-0627	1	VIS HEX. 5/16-24:.750 GR5:LOCK	FINISH:MTD SPEC-100015
10	710-3015	2	VIS:1/4-20:.75:GR5:STD	FINISH:MTD SPEC-100015
11	712-0431	2	ECROU STOP 3/8-16:GRF	FINISH:MTD SPEC-100015
12	712-0700	1	ECROU HEXAGONAL	SPEC-100015+WAX 912-0700
13	712-3027	3	ECROU HEXAGONAL 1/4 20:GRF	FINISH:MTD SPEC-100015
14	714-0209	1	GOUPILLE FENDUE	FINISH:SPEC 701-01006 914-0209
15	718-04012	1	CAGE DE PALIER	FINISH:ROSTSCHUTZ
16	718-0758A	1	ENTRETOISE DE POULIE	VERZAHNUNG 918-0758A
17	736-0362	1	RONDELLE .320ID X 1.25 ODX .0	FINISH:SPEC-100016
19	738-0372B	2	RONDELLE EPAULEE	FINISH:GEÖLT
20	741-0600	2	ROULEMENT ; BILLES	741-0600/941-0600
21	747-04072	1	SCHALTSTANGE	747-04072
22	750-04099	1	ENTRETOISE	750-04099 / 950-04099
23	754-04001A	1	COURROIE TRANSMISSION	954-04001A
24	754-04002	1	COURROIE	954-04002
25	756-04002	1	POULIE DE PONT	FINISH:SIEHE ZG. 956-04002

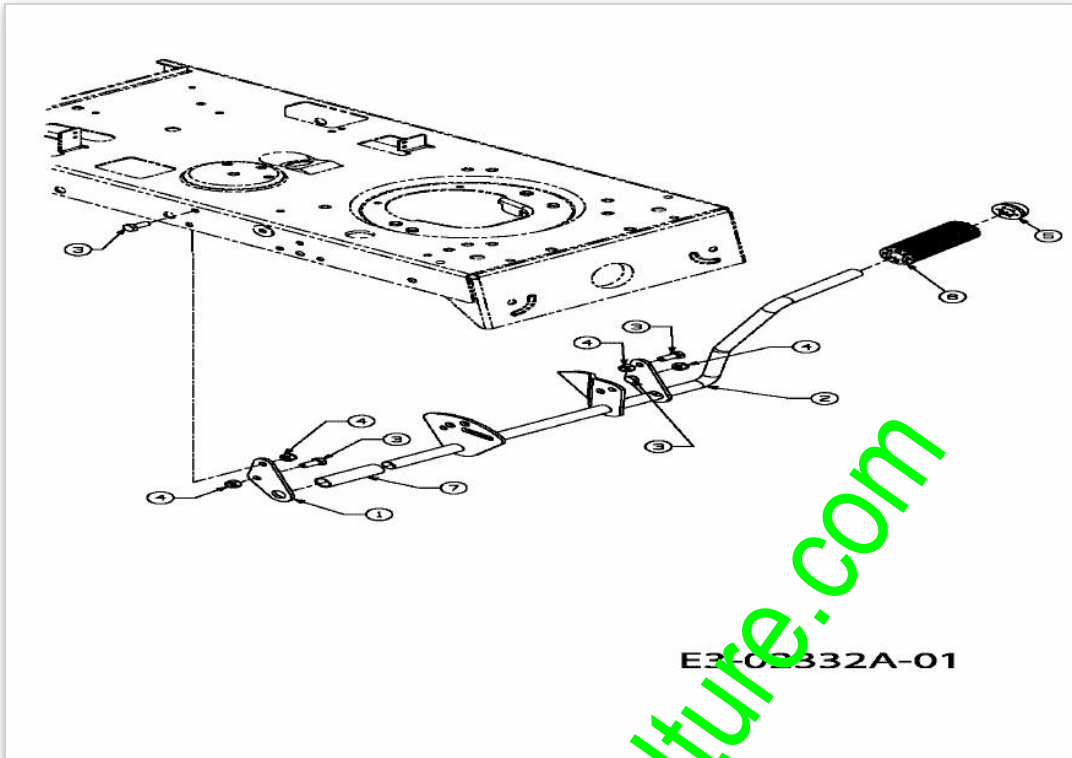

www.emc-motoculture.com

Position	Numéro de lapièce	#	Appellation I	Appellation II
1	17860	1	SUPPORT PEDALE	17860-0637
2	683-04005A	1	LEVIER	683-04005A-0637
3	710-3008	4	VIS 5/16-18:.75:GR5:STD	SPEC-701-01006 or.SPEC-100015
4	712-0429	4	ECROU	FINISH:SPEC-100015
5	726-0214	1	BOUCHON	FINISH:SCHWARZ
6	735-0239	1	CAOUTCHOUC/PEDALE 4;0 LG	FINISH:SCHWARZ
7	750-0802	1	ENTRETOISE / .640IDX.760DX2.63	FINISH:KUNSTSTOFF SCHWARZ

www.emc-motoculture.com

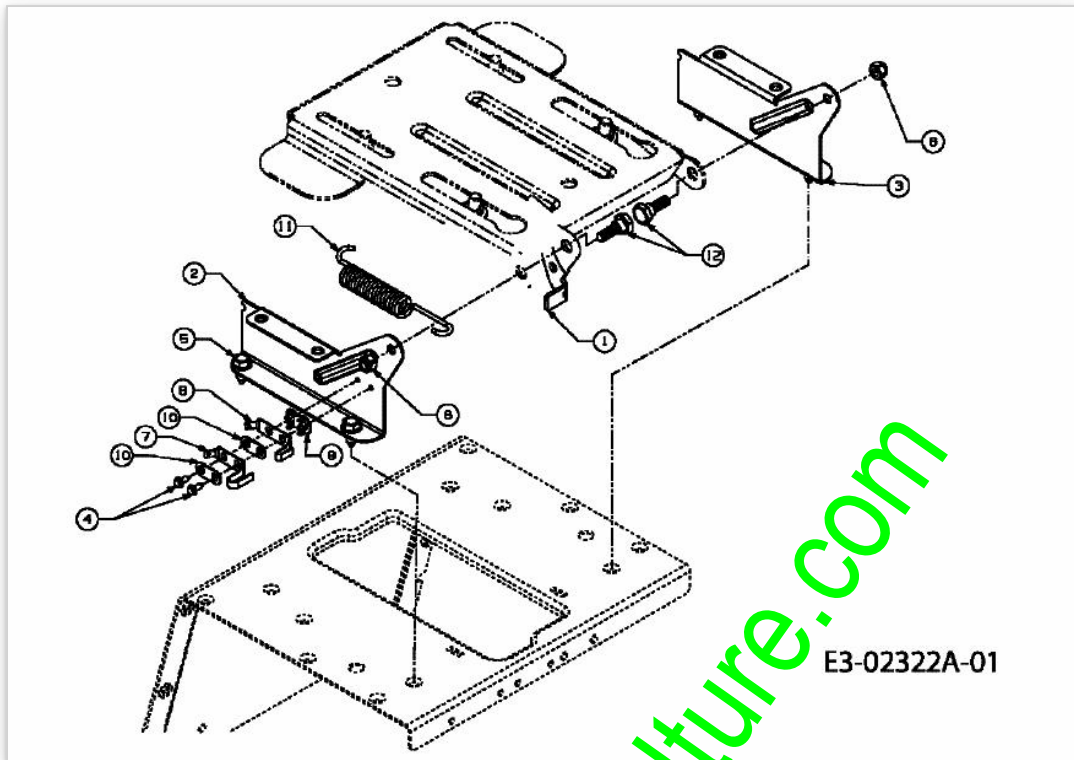

www.emc-motoculture.com

Position	Numéro de pièce	#	Appellation I	Appellation II
1	17239C	1	LEVIER DE CONTACT	FINISH:MTD STD 701-01002
2	17950A	1	EQUERRE DE FIXATION DROITE	17950A-0637
3	17951A	1	SUPPORT GAUCHE	17951A-0637
4	710-0227	2	VIS	FINISH:MTD SPEC-100016 TYPE 1
5	710-0726	4	VIS 5/16-12:0.750:HXINDWS	FINISH:MTD STD 701-01002
6	712-0429	2	ECROU	FINISH:SPEC-100015
7	725-1303	1	RESSORT DE SURETE SIÈGE	SI.-SCHALTER SITZ:SPEC-100015
8	725-1439	1	RESSORT SURETE DE SIEGE	SI.-SCHALTER SITZ:SPEC-100015
9	726-0278	1	PLAQUE D'ISOLATION	FINISH:NATUR ODER SCHWARZ
10	726-0279	2	PLAQUE D'ISOLATION	FINISH:NATUR ODER SCHWARZ
11	732-0581B	1	RESSORT DE TRACTION	732-0581B
12	738-0296	2	AXE EPAULE	FINISH:SPEC-100015

www.emc-motoculture.com

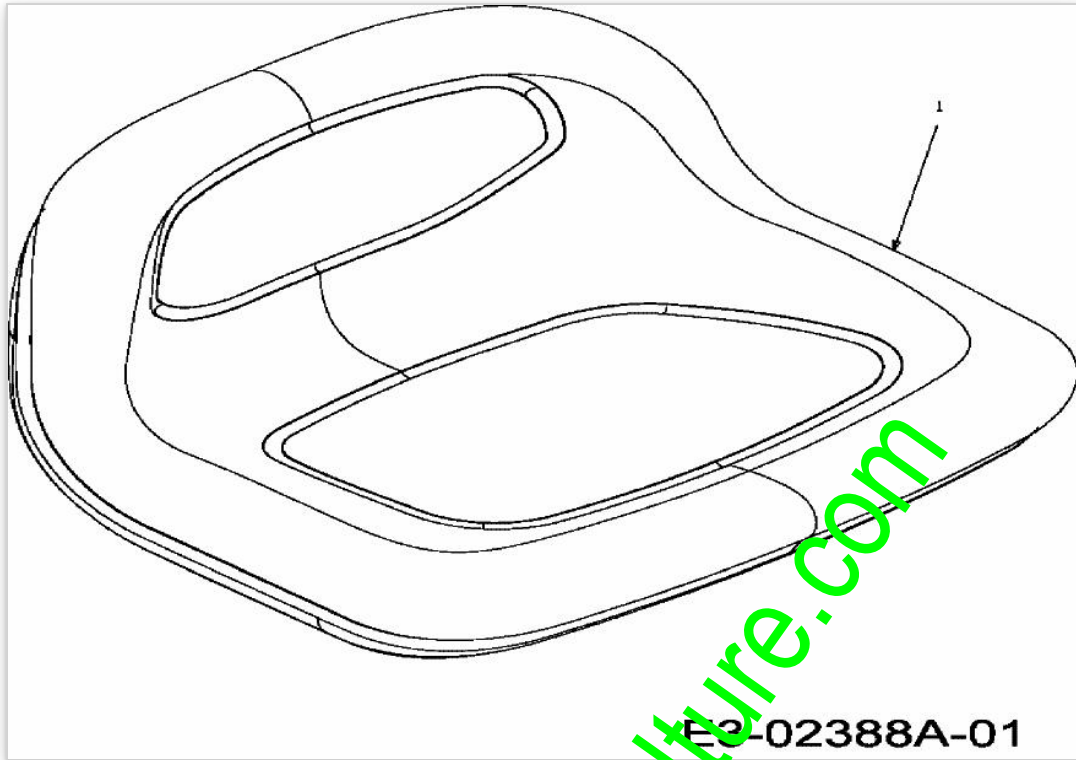

www.emc-motoculture.com

Position	Numéro de pièce	#	Appellation I	Appellation II
1	757-04021A	1	SITZ:NIEDRIGE RÜCKLEHN. MILSCO	SCHWARZ

www.emc-motoculture.com

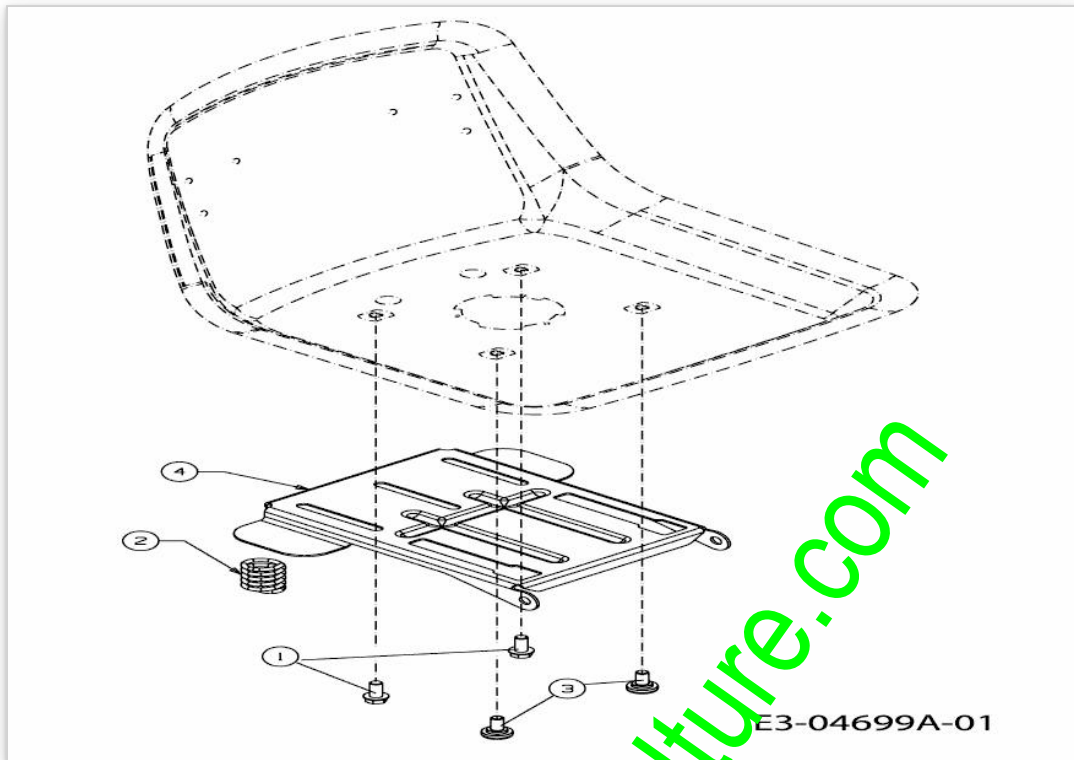

www.emc-motoculture.com

Position	Numéro de lapièce	#	Appellation I	Appellation II
1	710-04482	2	VIS:3/8-16:.875:GR5:STD	FINISH:MTD SPEC-100015
2	732-04038	2	RESSORT DE SIEGE	732-04038 / 932-04038
3	738-04012A	2	VIS EPAULEE	FINISH:SIEHE ZG.
4	783-04081C	1	783-06352637	FINISH:LACKIERT

www.emc-motoculture.com

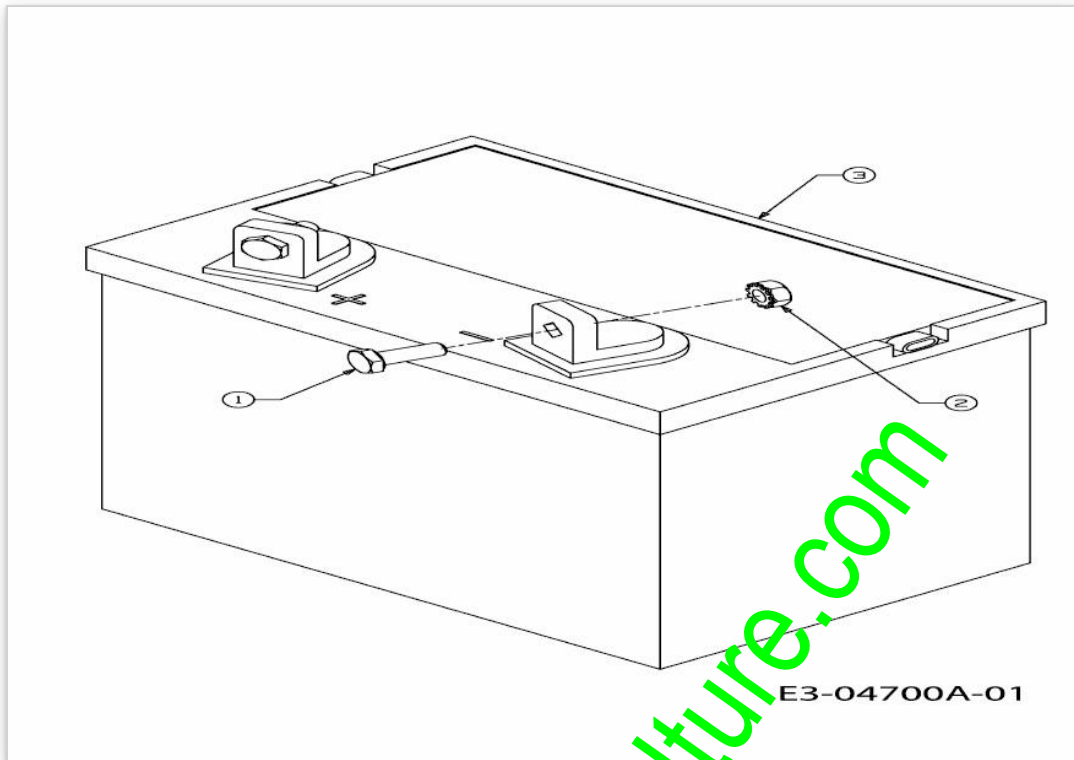

www.emc-motoculture.com

Position	Numéro de lapièce	#	Appellation I	Appellation II
1	710-3015	2	VIS:1/4-20:.75:GR5:STD	FINISH:MTD SPEC-100015
2	712-0271	2	ECROU 1/4-20"+ DISQUE DENTE	FINISH:MTD SPEC-100016 GR5
3	725-2057A	1	BATTERIE 12 V 24 A 210x125x185	BELÜFTUNG OBEN OHNE SÄURE

www.emc-motoculture.com

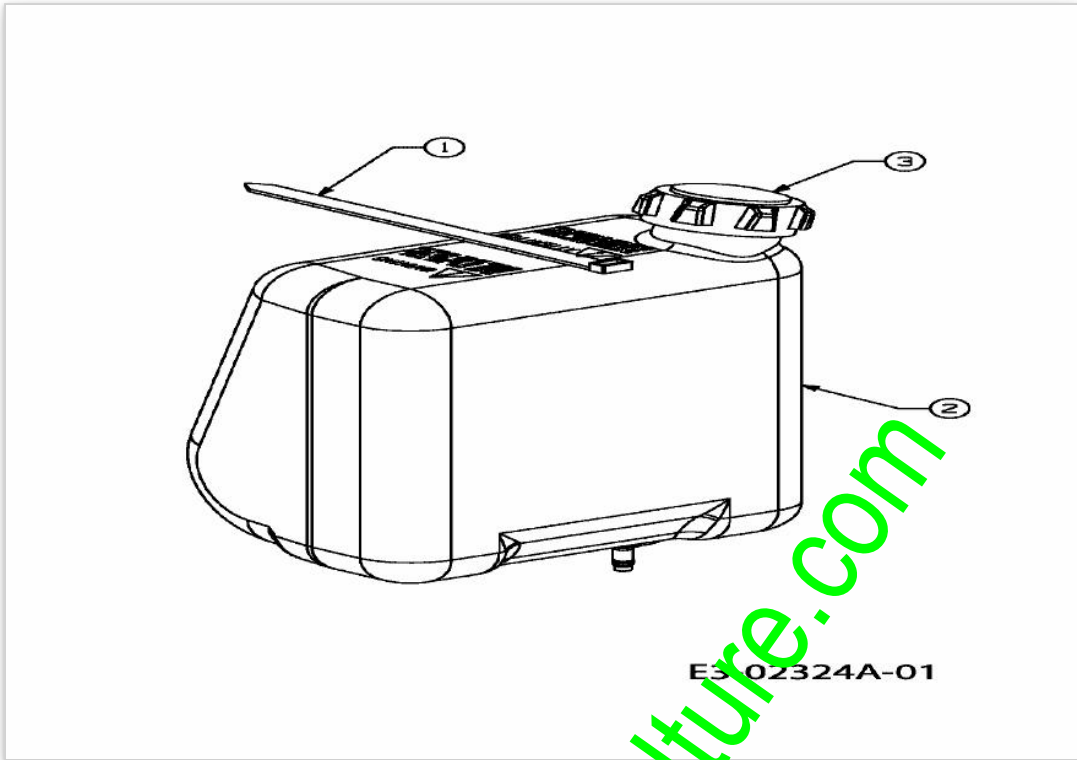

E3_02324A-01

www.emc-motoculture.com

Position	Numéro de lapièce	#	Appellation I	Appellation II
1	726-0230	1	COLLIER	FINISH: SCHWARZ
2	751-0555B	1	RESERVOIR D'ESSENCE: 5.7L	FINISH: NATUR
3	751-0603	1	BOUCHON RESERVOIR ESSENCE	FINISH: SCHWARZ

www.emc-motoculture.com

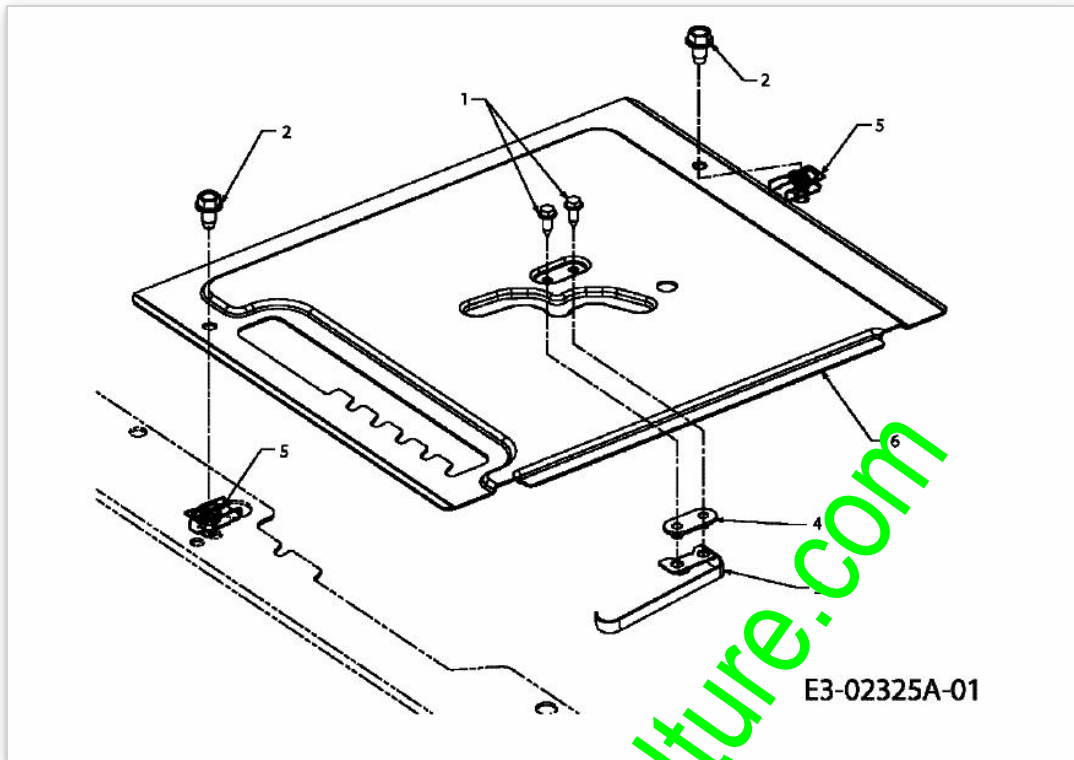

www.emc-motoculture.com

Position	Numéro de lapièce	#	Appellation I	Appellation II
1	710-0227	2	VIS	FINISH:MTD SPEC-100016 TYPE 1
2	710-0599	2	VIS A SIX PANS CREUX	FINISH:MTD SPEC-101617
3	725-1643	1	CONTACTEUR SECURITE	LANG:FINISH:SPEC-100016
4	726-0320	1	PLAQUE D'ISOLATION	FINISH:NATUR ODER SCHWARZ
5	726-3054	2	ECROU	FARBE:METALLIC GRAY
6	783-04060A	1	COUVERCLE	783-04060A-0637

www.emc-motoculture.com

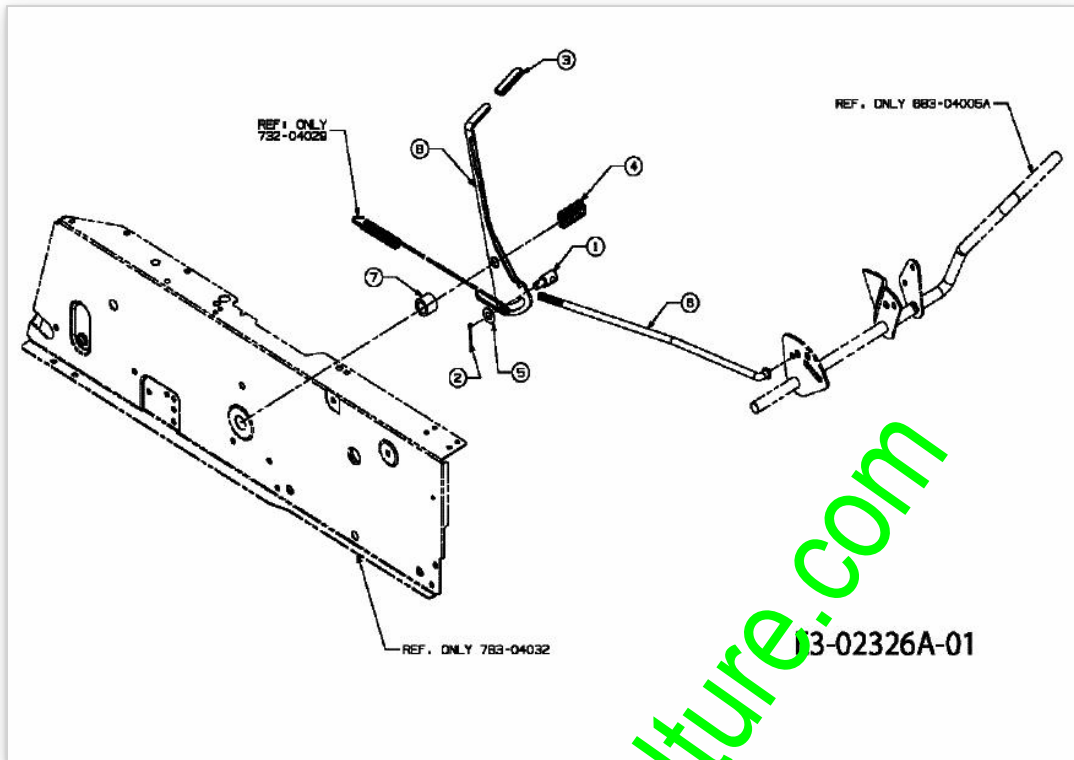

www.emc-motoculture.com

Position	Numéro de pièce	#	Appellation I	Appellation II
1	711-04075A	1	EMBOUT	FINISH:MTD SPEC-100015
2	714-0111	1	GOUPILLE FENDUE 3/32:1.0"	FINISH:MTD SPEC-100015
3	720-04008	1	HANDGRIFF	720-04008
4	732-04017	1	RESSORT DE PRESSION	732-04017 / 932-04017
5	736-0300	1	RONDELLE	FINISH:MTD SPEC-100015
6	747-04039	1	TRINGLE CHANGEMENT DE VITESSE	747-04039
7	750-04080	1	ENTRETOISE	750-04080 / 950-04080
8	783-04059	1	LEVIER SELECTEUR VTS	783-04059

www.emc-motoculture.com

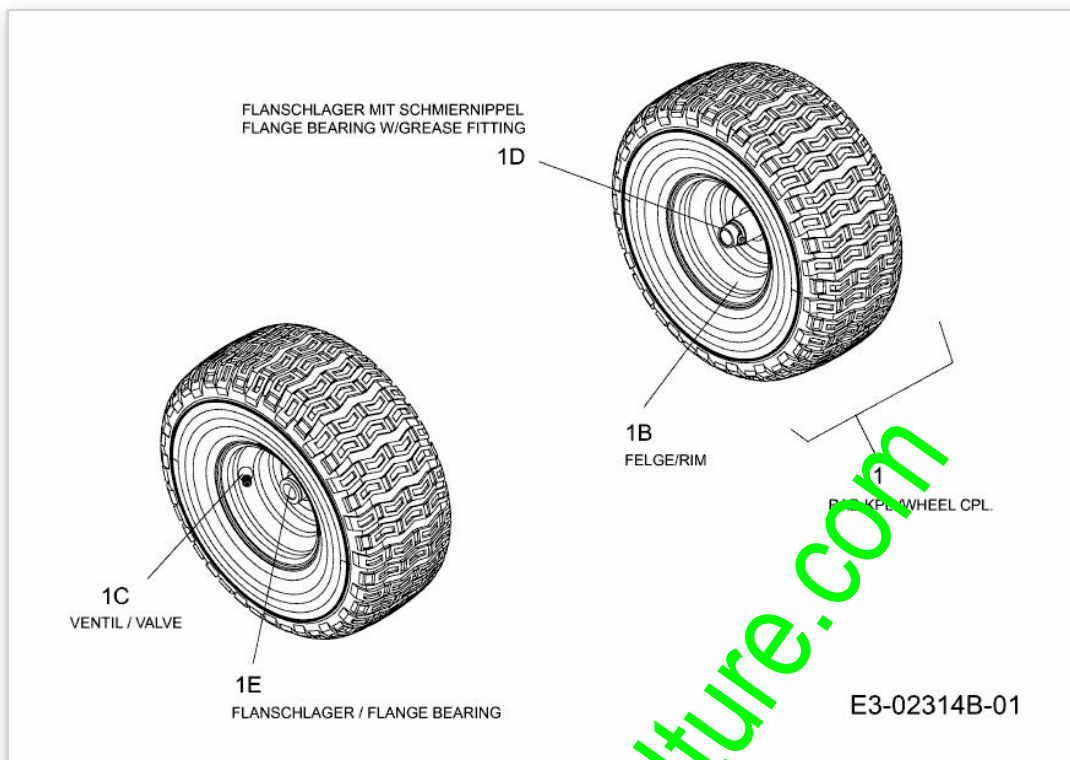

Position	Numéro de pièce	#	Appellation I	Appellation II
1	634-04325662	2	ROUE COMPLETE 15X600X6	FINISH:OYSTER GRAY 788-0662
1B	634-04081662	2	JANTE AV 6.0x4.5 GRISE	OYSTERGRAU 788-0662
1C	734-0255	2	VALVE:PNEU	TR 412-P / 32.6mm / 934-0255
1D	741-0990B	1	BAGUE DE ROUE AVEC GRAISSEUR	m.SCHMIERNIPPEL:FINISH SCHWARZ
1E	741-0516	1	SUPPORT DE BRIDE .757 X 1	.757IDx1.00 ODx1.2LG/ 941-0516

www.emc-motoculture.com

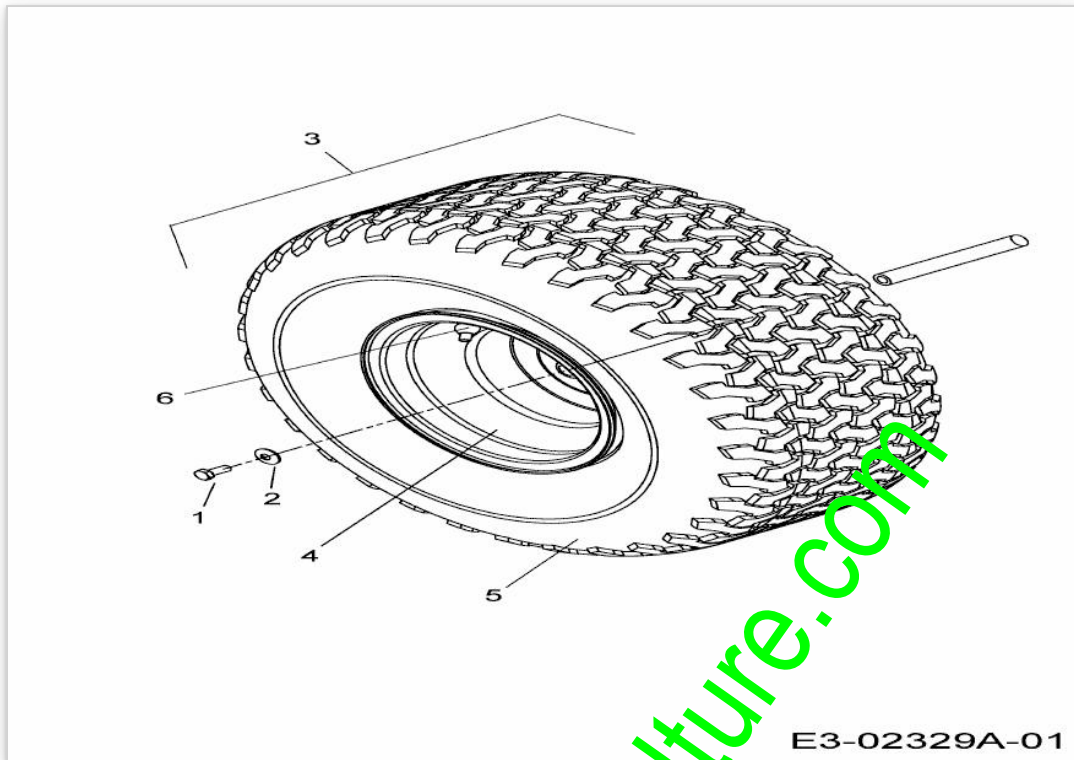

E3-02329A-01

www.emc-motoculture.com

Position	Numéro de lapièce	#	Appellation I	Appellation II
1	710-0627	2	VIS HEX. 5/16-24:.750 GR5:LOCK	FINISH:MTD SPEC-100015
2	736-0242	2	RONDELLE CONIQUE.340X.872X.060	FINISH:MTD SPEC-100016
3	734-1675	2	ROUE COMPL 20X8;00-8 ST	734-1675-0911
4	634-0070	2	JANTE	FINISH:788-0499/674/0662
5	734-1596	2	PNEU 20 X 8.00.8 ST	BLOCK TURF PRO: RND SHL
6	734-0255	2	VALVE:PNEU	TR 412-P / 32.6mm / 934-0255

www.emc-motoculture.com

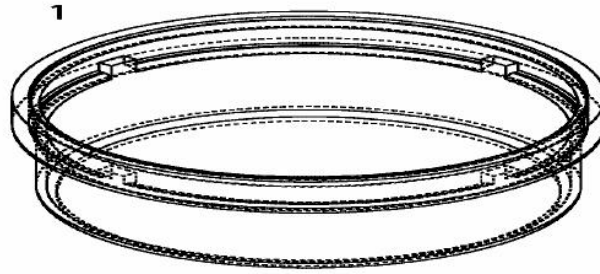

3-02002A-01

www.emc-motoculture.com

Position	Numéro de lapièce	#	Appellation I	Appellation II
1	731-0484A	2	ENJOLIVEUR DEVANT	KUNSTSTOFF SCHWARZ 931-0484A

www.emc-motoculture.com

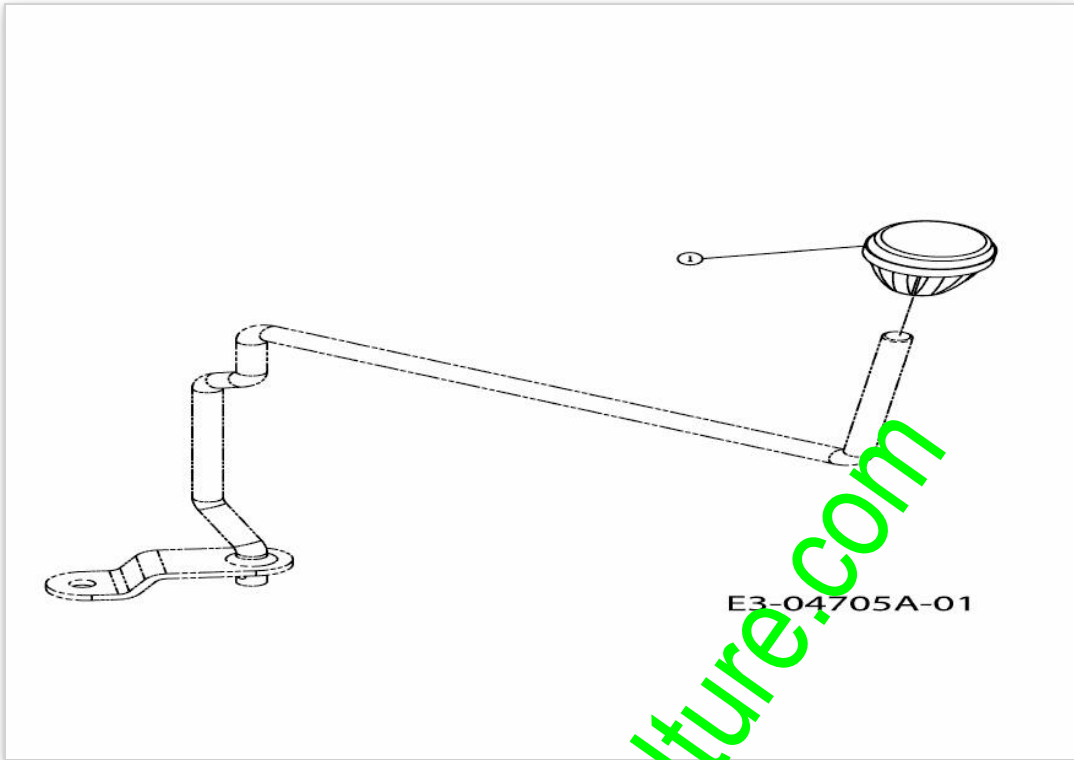

www.emc-motoculture.com

Position	Numéro de lapièce	#	Appellation I	Appellation II
1	720-0232	1	BOUTON DE LEVIER MANUEL	FINISH:KUNSTSTOFF SCHWARZ

www.emc-motoculture.com

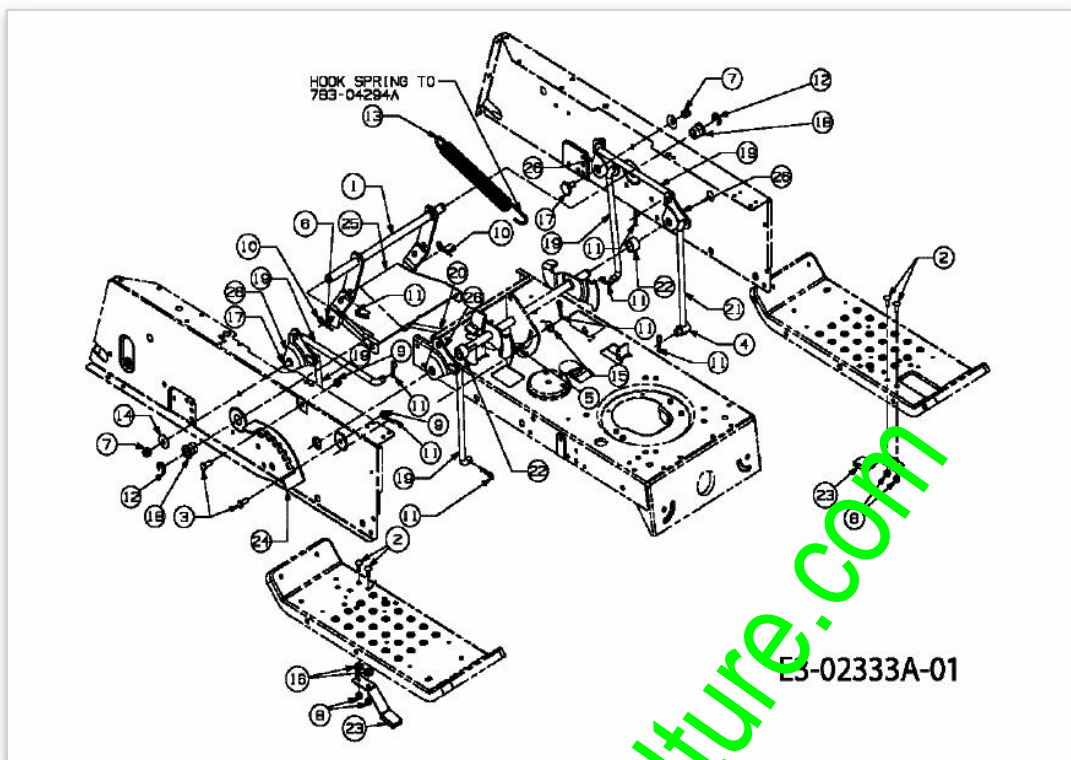

Position	Numéro de pièce	#	Appellation I	Appellation II
1	683-04048A	1	LEVIER DE RELEVAGE	683-04048A-0637
2	710-0703	4	VIS	FINISH:MTD SPEC-100015
3	710-3008	2	VIS 5/16-18:.75:GR5:STD	SPEC-701-01006 or.SPEC-100015
4	711-04036	1	AXE	FINISH:SPEC-100015 911-04036
5	711-04075A	1	EMBOUT	FINISH:MTD SPEC-100015
6	711-1421	2	BOULON	711-1421
7	712-0130	2	ECROU POLY STOP 3/8-16" GR 8	FINISH:MTD SPEC-100015
8	712-0324	4	ECROU HEX.:1/4-20:GR8:NYLON	FINISH:701-01000
9	712-0429	2	ECROU	FINISH:SPEC-100015
10	714-0145	2	GOUPILLE	FINISH:SPEC-701-01006
11	714-04023	8	GOUPILLE	GLANZVERZINKT 914-04023
12	716-0106A	2	CIRCLIPS	FINISH:PHOSPHATIERT
13	732-04050D	1	RESSORT	732-04050D
14	736-0219	2	RONDELLE	FINISH:701-01001
15	736-0267	1	RONDELLE PL.:.385 x .87 x.06:HT	701-01001 OPTIONAL SPEC-100015
16	736-3008	2	RONDELLE	FINISH:MTD SPEC-100015
17	738-0322	2	AXE	FINISH:VERZINKT SIEHE ZG.
18	741-0487C	2	BAGUE DE ROUE	FINISH:SCHWARZ
19	747-04018A	5	ECLISSE DE SUSPENSION	947-04018A
20	747-04040A	1	TRINGLE	747-04040A
21	747-04069A	1	TRINGLE	747-04069A
22	748-04037A	2	ENTRETOISE	748-04037A
23	761-0168D	2	PATIN DE FREIN	961-0168D RP 961-0168B
24	783-04113	1	SELECTEUR HAUTEUR DE COUPE	783-04113P
25	783-04294A	1	SUPPORT STABILISANT NOIR	783-04294A-0637
26	783-04307	4	HALTERUNG	783-04307-0637

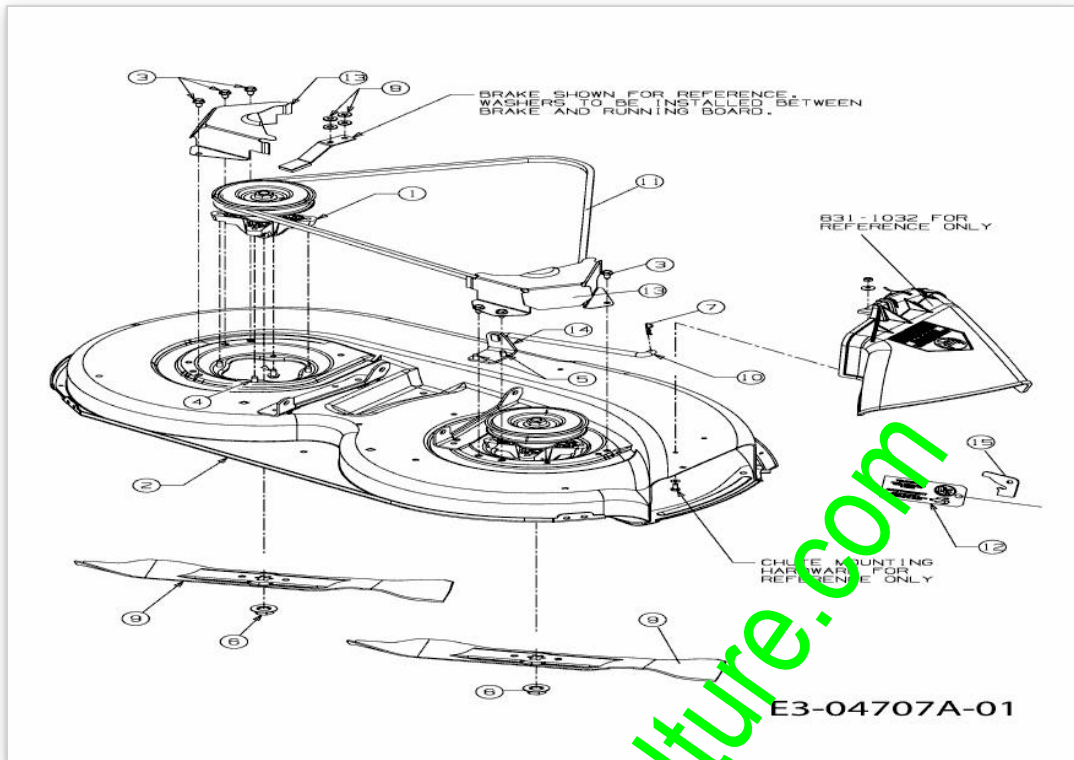

www.emc-motoculture.com

Position	Numéro de pièce	#	Appellation I	Appellation II
1	618-0142A	2	PALIER LAME COMPLET COUPE107CM	KEILRIEMENSCH:Ø 5.75 618-0142A
2	683-04004A	1	CARTER 42"	983-04004A-0637
3	710-0726	6	VIS 5/16-12:0.750:HXINDWS	FINISH:MTD STD 701-01002
4	710-1260A	8	VIS TT:5/16-18:.750	FINISH:SPEC-100016 TYPE 1
5	710-1611B	2	VIS:TT:5/16- 18:0.750:PANTRXI	FINISH:MTD SPEC-100015
6	712-0417A	2	ÜCROU HEX. AV. FLANC: 5/8-18	FINISH:MTD STD 701-01000
7	714-04023	1	GOUPILLE	GLANZVERZINKT 914-04023
8	736-3008	4	RONDELLE	FINISH:MTD SPEC-100015
9	742-0616A	2	LAME MULCHING	742-0616A637 942-0616A *
10	747-04018A	1	ECLISSE DE SUSPENSION	947-04018A
11	754-0371A	1	COURROIE DE LAME COUPE 107CM	754-0371A/954-0371A
12	771-11725A	1	AUTOCOLLANT PLATEAU RT99	RT 99:ENGLISCH/FRANZÖSISCH
13	783-04149A	2	KEILRIEMENABDECKUNG	783-04149A-0637
14	783-04211	1	SUPPORT	783-04211-0637
15	783-1025	1	PLAQUE ACCROCHE DEFLECTEUR	FINISH:VERZINKT

www.emc-motoculture.com

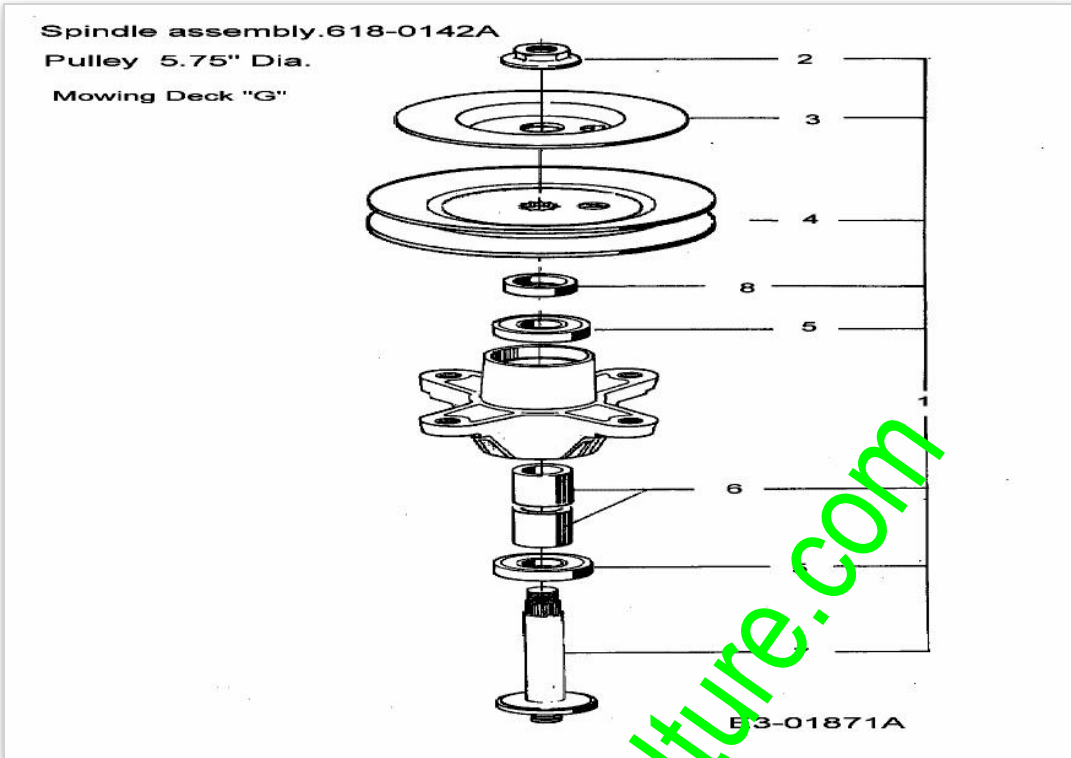

www.emc-motoculture.com

Position	Numéro de lapièce	#	Appellation I	Appellation II
1	618-0142A	1	PALIER LAME COMPLET COUPE107CM	KEILRIEMENSCH:Ø 5.75 618-0142A
2	712-0417A	1	ÜCROU HEX. AV. FLANC: 5/8-18	FINISH:MTD STD 701-01000
3	783-0342A	1	DISQUE DE FREIN	FINISH:ZINC w/CHROMATE
4	756-1188	1	POULIE DE COURROIE TRAPEZ.	SPEC-100015 or AUTOPHORETIC C.
5	741-0919	2	ROULEMENT ; BILLES	FINISH:SIEHE SPEC.
6	750-1000	2	ENTRETOISE:.80x1.10x1.330	FINISH:GEÖLT
7	738-0933	1	AXE DE PALIER DE LAME	FINISH:GEÖLT
8	748-0434	1	ENTRETOISE	FINISH:GEÖLT

www.emc-motoculture.com

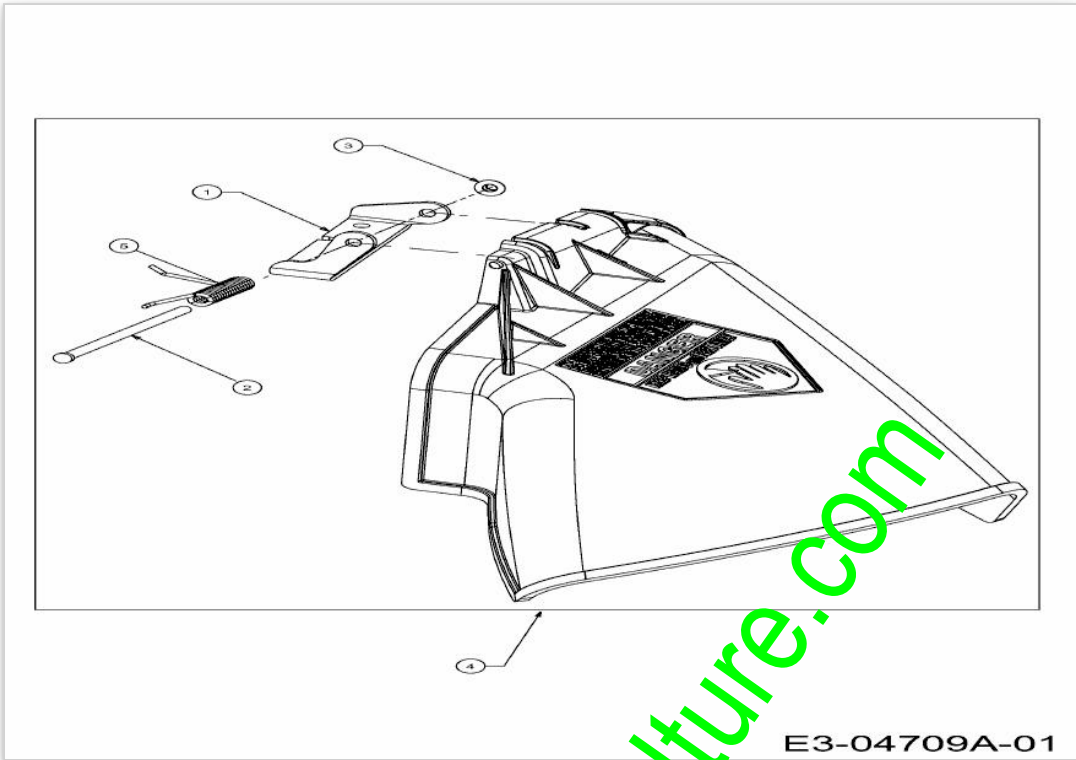

www.emc-motoculture.com

Position	Numéro de lapièce	#	Appellation I	Appellation II
1	703-1693A	1	SUPPORT DE DEFLECTEUR	FINISH:BLAU CHROMATIERT *
2	711-0792	1	GOUJON	MTD SPEC-100015 911-0792
3	726-0106	1	COUVERCLE 1/4 "	FINISH:MTD SPEC-100016
4	731-1032B	1	CLAPET D'ÜJECTION	SEITENAUSWURF 931-1032B
5	732-0602A	1	RESSORT	FINISH:MTD STD 701-01000

www.emc-motoculture.com

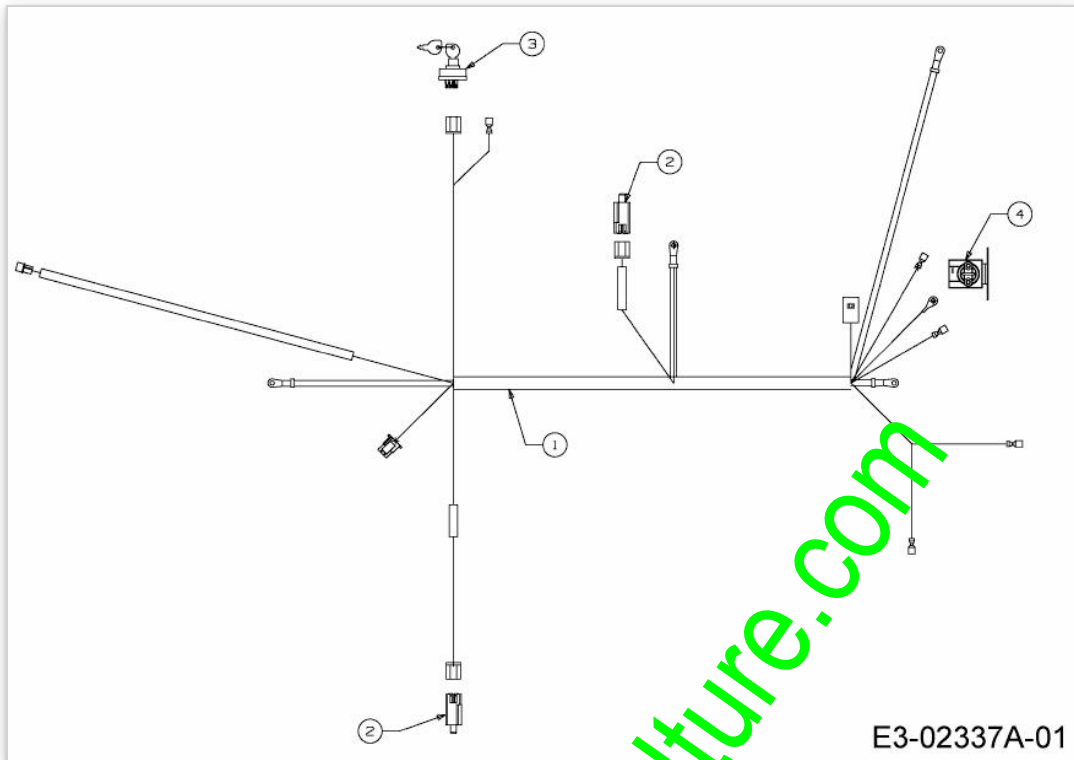

E3-02337A-01

www.emc-motoculture.com

Position	Numéro de lapièce	#	Appellation I	Appellation II
1	629-04015	1	TABLEAU PPL MOTEUR CONDUCTEUR	929-04015
2	725-04039	2	SECURITE	FINISH:GRAY/BLACK 925-04039
3	725-1396A	1	CONTACTEUR A CLE 6 FICHES	MIT SCHLÜSSEL:6 PIN
4	725-1426	1	RELAIS DE DEMARRAGE SOLENOID	725-1426 Mutter 712-0271

www.emc-motoculture.com

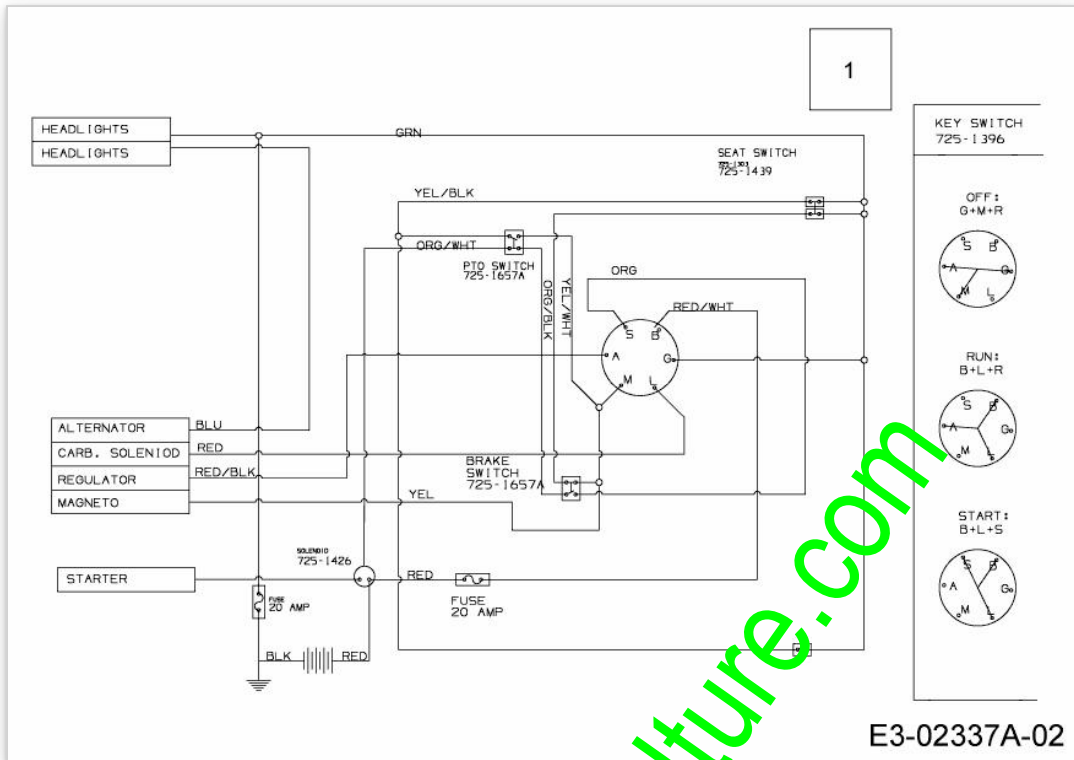

Position	Numéro de lapièce	#	Appellation I	Appellation II
1	629-04015	1	TABLEAU PPL MOTEUR CONDUCTEUR	929-04015

www.emc-motoculture.com

www.emc-motoculture.com