

www.emc-motoculture.com

Position	Numéro de pièce	#	Appellation I	Appellation II
1	618-04617	1	TRANSMISSION	618-04617
1A	731-05100	1	LEVIER PLASTIQUE	731-05100
2	710-04531	2	VIS	FINISH:MTD SPEC-100015
3	715-0221	2	CHEVILLE CYLINDRIQUE	FINISH:SIEHE ZG.
4	717-04452	1	ENGRENAGE	16 ZÄHNE LINKS
5	717-04575	2	PIGNON:23 DENTS:ENTR. DE ROUE	SINTER
6	717-04457	1	PIGNON	16 ZÄHNE RECHTS
7	731-06145	2	COUVERCLE DE ROUE	12"HIGH WHL:SP:EX
8	732-04531	1	RESSORT DE TRACT.:.375ODx2.2LG	FINISH:MTD SPEC-100015
9	748-04016A	1	SUPPORT DE LAME	748-04016A
10	750-05017	1	DOUILLE	MATERIAL:PLASTIK SCHWARZ
11	750-05018	1	ENTRET. D'ECART.:.550IDx8.825	PLASTIK SCHWARZ
12	754-04184	1	COURROIE	POLY
13	787-01645	2	PLAQUE SUPPORT CHACHE ROUE	12" HIGH WHEEL:BLACK OXYDE
14	752S180S50	1	MOTEUR KAWA 6 CH FH 180	FJ180V-AS50
14A	752Z1P70MH	1	MOTEUR MTD	1P70MH
14B	752B0611B1	1	MOTEUR B&S 650 SERIES ES	124T05-0611-B1
14C	752B4567B1	1	B-MOTEUR B&S 650 START	124T02-4567-B1 READY START
14D	752Z5P70MH	1	MOTOR 173 CC OHV VERTIC SHAFT	5P70MH AUTOCHOKE
14E	752B1960B1	1	MOTEUR B&S QUANTUM	12F802-1960-B1 190 CC

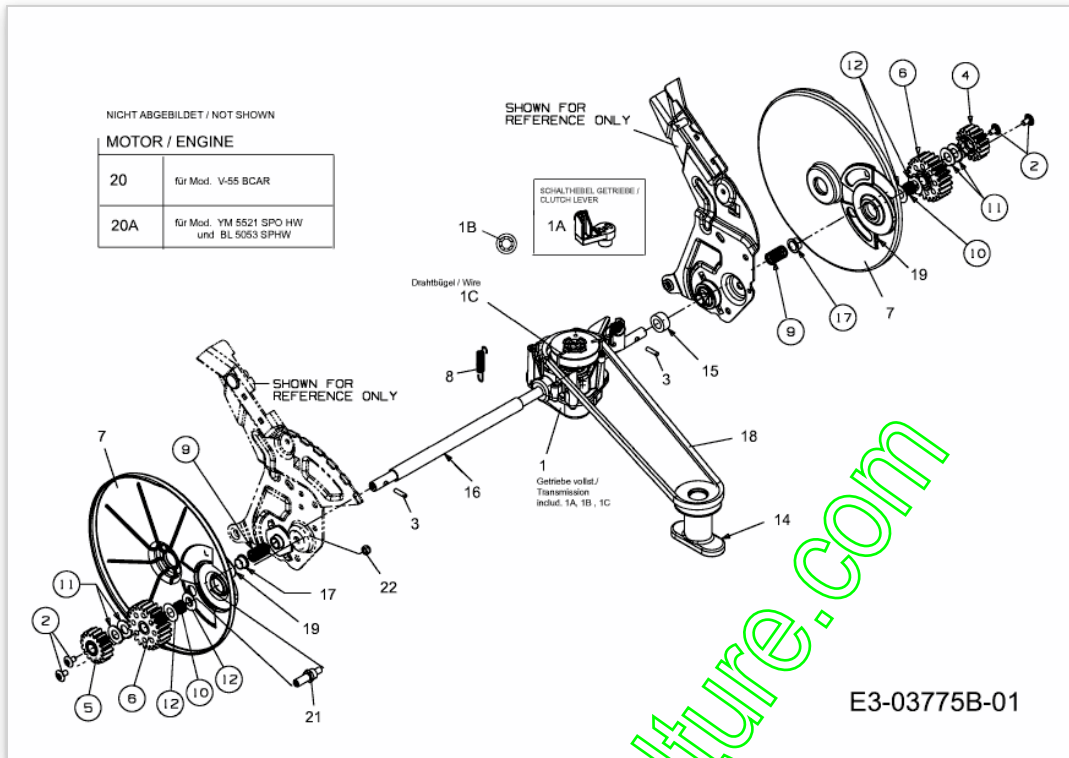

Position	Numéro de pièce	#	Appellation I	Appellation II
1	618-04617A	1	BOITE DE VITESSE	618-04617A
1A	731-05100	1	LEVIER PLASTIQUE	731-05100
1B	726-04043	1	CLIPS	MECHANISCH VERZINKT:SIEHE ZG.
1C	732-04509	1	GUIDE COURROIE	732-04509
2	710-04531	2	VIS	FINISH:MTD SPEC-100015
3	715-0221	2	CHEVILLE CYLINDRIQUE	FINISH:SIEHE ZG.
4	717-04577A	1	PIGNON GAUCHE 16 DENTS	717-04577A
5	717-04578A	1	PIGNON DROIT 16 DENTS	717-04578A
6	717-04678	2	PIGNON 23 DENTS	717-04678
7	731-06145B	2	COUVERCLE DE ROUE	731-06145B
8	732-04531	1	RESSORT DE TRACT...375ODx2.2LG	FINISH:MTD SPEC-100015
9	732-04557	2	RESSORT DE PRESSION	FINISH:MTD-SPEC 101616
10	732-04650	2	RONDELLE ELASTIQUE	FINISH:ÖL GEDIPPT
11	736-0272	4	RONDELLE .510x1.00X.060	FINISH:MTD-SPEC 100015
12	736-0369	4	RONDELLE	FINISH:SIEHE ZG. 936-0369
14	748-04016A	1	SUPPORT DE LAME	748-04016A
15	750-05017	1	DOUILLE	MATERIAL:PLASTIK SCHWARZ
16	750-05205	1	ENTRETOISE D'ECARTEMENT	700-02006
17	750-05250	2	SUPPORT DE BRIDE	.51DX0.58ODX.35LG
18	754-04184	1	COURROIE	POLY
19	787-01645	2	PLAQUE SUPPORT CACHE ROUE	12" HIGH WHEEL:BLACK OXYDE
20	752B4567B1	1	B-MOTEUR B&S 650 START	124T02-4567-B1 READY START
20A	752Z5P70MH	1	MOTOR 173 CC OHV VERTIC SHAFT	5P70MH AUTOCHOKE
21	711-05092	2	TIGE FILETEE	FINISH:PHOS AND OIL SIEHE ZG.
22	712-04074	2	ECROU:M10x1.25 DIN 985-8	FINISH:MTD SPEC-100015

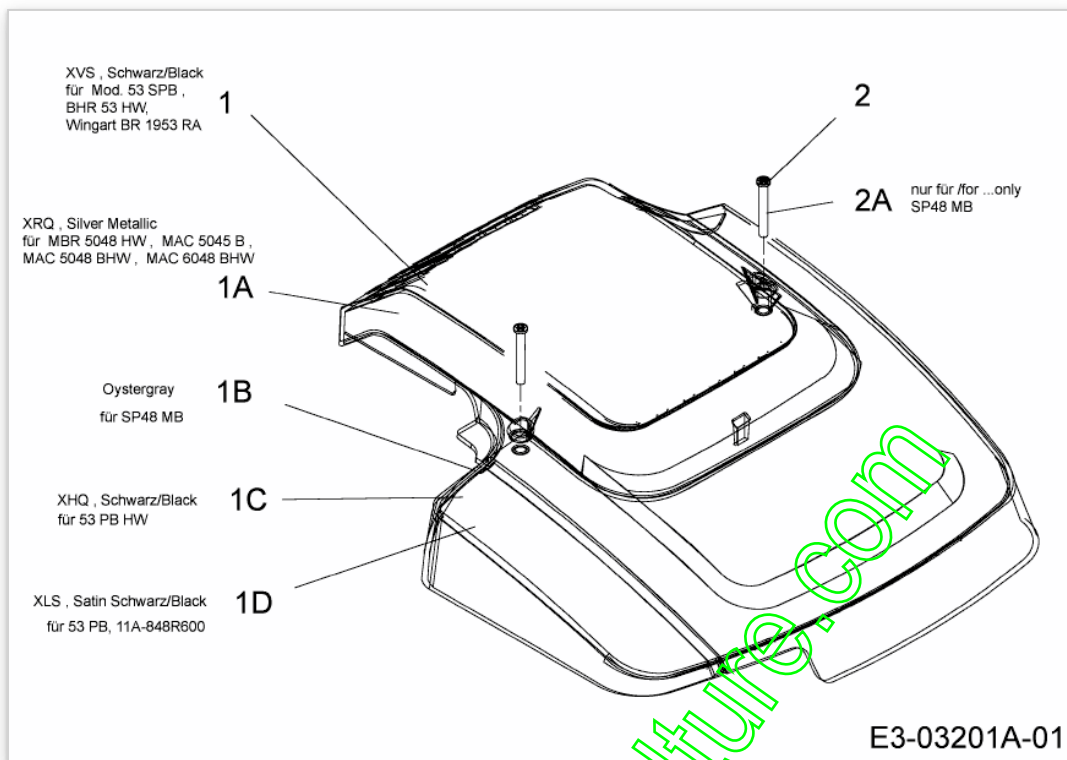

Position	Numéro de lapièce	#	Appellation I	Appellation II
1	751B698269	1	CAPOT DE MOTEUR NOIR	751B698269
1A	751B790846	1	COUV. MOTEUR B&S XRQ METALLIC	SILBER
1B	751B795527	1	CAPOT DE MOTEUR GRIS	795527
1C	751B795164	1	CAPOT DE MOTEUR NOIR	550 Series B&S
1D	751B698255	1	CAPOT DE MOTEUR	698255
2	751B095050	2	VIS B&S	ZYLINDERKREUZSCHRAUBE
2A	751B095225	2	VIS $\dot{\bar{I}}$ SIX PANS CREUX	

www.emc-motoculture.com

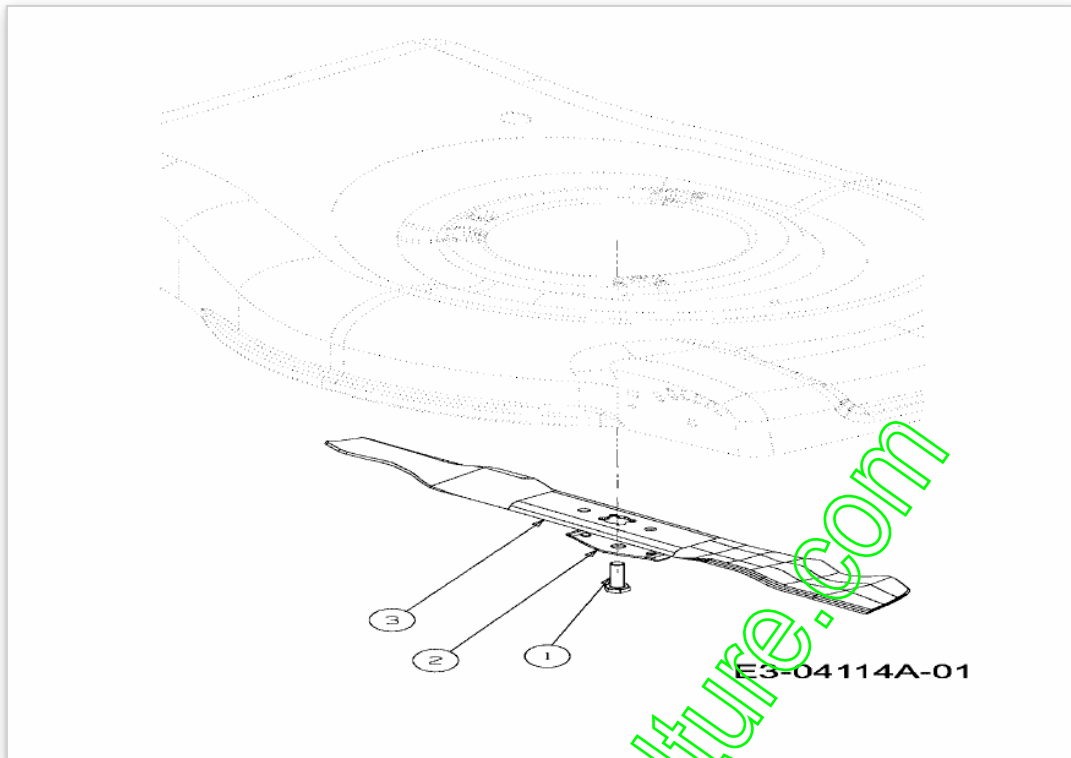

E3-04114A-01

www.emc-motoculture.com

Position	Numéro de lapièce	#	Appellation I	Appellation II
1	710-1044	1	VIS A SIX PANS CREUX	FINISH:SIEHE ZG
2	736-0524B	1	PLAQUE D'ARRET RESS. ACIER	FINISH:SIEHE ZG.
3	742-0741	1	LAME MULCHING COUPE 53CM ETOIL	FINISH:SIEHE ZG.

www.emc-motoculture.com

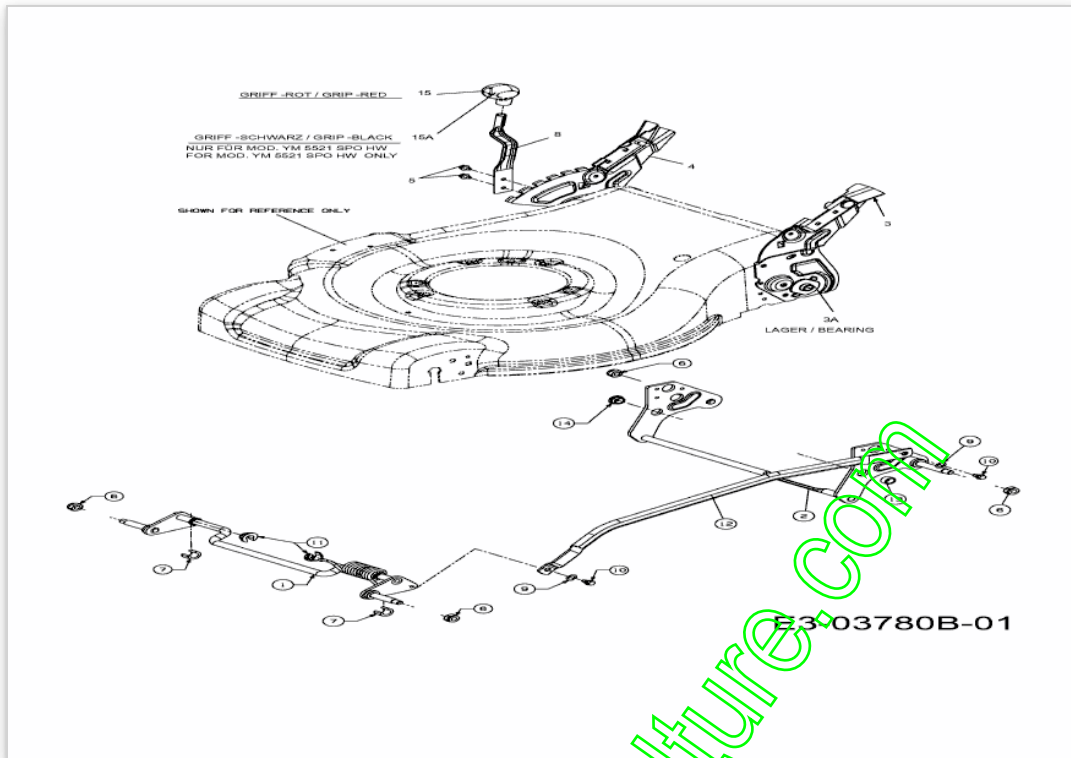

Position	Numéro de pièce	#	Appellation I	Appellation II
1	687-02368637	1	ESSIEU AVANT NOIR	MTD SCHWARZ
2	687-02380637	1	ESSIEU ARRIERE NOIR	MTD SCHWARZ
3	687-02395637	1	SUPPORT DE RELEVAGE DROIT	MTD SCHWARZ
3A	687-02362	2	ROULEMENT	687-02362
4	687-02393637	1	SUPPORT DE RELEVAGE DROIT	MTD SCHWARZ
5	710-0653	2	VIS A SIX PANS CREUX	FINISH:MTD SPEC-100016
6	712-04074	4	ECROU:M10x1.25 DIN 985-8	FINISH:MTD SPEC-100015
7	731-05470	2	ANNEAU DE SERRAGE D'AXE	731-05470
8	732-04480A	1	LEVIER HAUTEUR DE COUPE	732-04480A
9	736-3012A	1	RONDELLE	FINISH: GELB VERZINKT
10	738-04278	2	VIS	FINISH:MTD STD SPEC-100016
11	741-04136B	2	PALIER DE FLASQUE	741-04136B SCHWARZ
12	749-04414637	1	BARRE DE CONNEXION RÉGLABLE	21" HIGHWHEELVERSION
13	750-05029	1	DOUILLE	.499X.685X.380 LG
14	750-05031	1	DOUILLE	.499X.860X.380 LG
15	720-04097	1	POIGN. P. LEV. DE DÜPL. HAUT.	FINISH:VERKEHRSROT 788-0719
15A	720-04096	1	POIGNE RÉGLAGE D'HAUTEUR	FINISH:SCHWARZ 788-0637

www.ens-motoculture.com

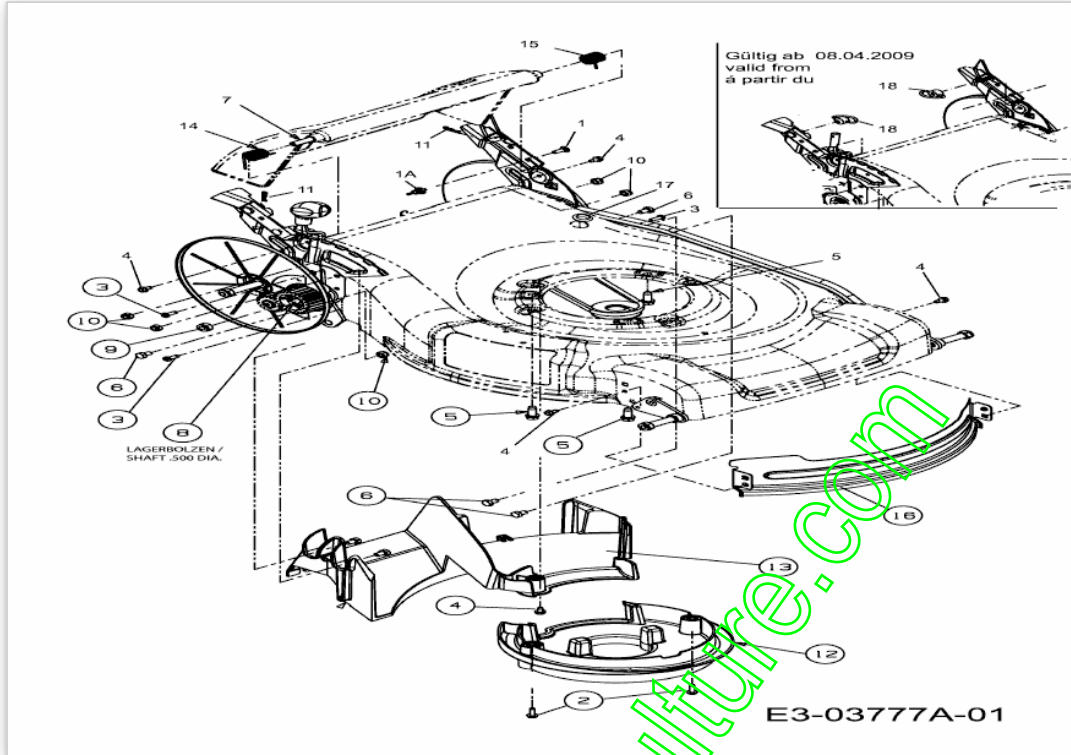

Position	Numéro de lapièce	#	Appellation I	Appellation II
1	710-0703	2	VIS	FINISH:MTD SPEC-100015
1A	712-0397	2	ÜCROU PAPILLON	FARBE:SCHWARZ 912-0397
2	710-04210	2	VIS	
3	710-04380	3	VIS A TETE CONIQUE BOMBEE	FINISH:MTD SPEC-100016 TYPE 1
4	710-0599	5	VIS A SIX PANS CREUX	FINISH:MTD SPEC-101617
5	710-0654A	3	VIS A SIX PANS CREUX	FINISH:GEOMET XL
6	710-1714	6	VIS A SIX PANS CREUX	MTD SPEC-100015 21.1441.67
7	711-04374	1	TIGE	FINISH:701-01000
8	711-04836	2	RADACHSE:.500 DIA x 2.456:M10	FINISH PHOSPHATE & OIL
9	712-04074	4	ECROU:M10x1.25 DIN 985-8	FINISH:MTD SPEC-100015
10	712-0692	6	ECROU HEXAGONAL 24.1426.18	FINISH:SPEC-100015 24.1426.18
11	714-0104	2	GOUPILLE	FINISH:PHOS AND OIL
12	731-06164	1	SUPPORT MOTEUR, NOIR	MATERIAL:PLASTIK SCHWARZ
13	731-06173	1	DÜFLECTEUR ARRIERE	FINISH:SCHWARZ
14	732-04264	1	RESSORT ROT. DROIT CLAPET ARR.	FINISH:701-01000
15	732-04265	1	RESSORT ROT. GAUCHE CLAPET ARR.	FINISH:701-01000
16	787-01532	1	TÛLE AVANT	FINISH:NONE E-TEIL SET
17	735-04059	1	JOINT D'ÉTANCHÉITÉ EN	FINISH:SCHWARZ
18	712-04207	2	ECROU	MIT BEWEGLICHEM KNEBEL

www.enj-motoculture.com

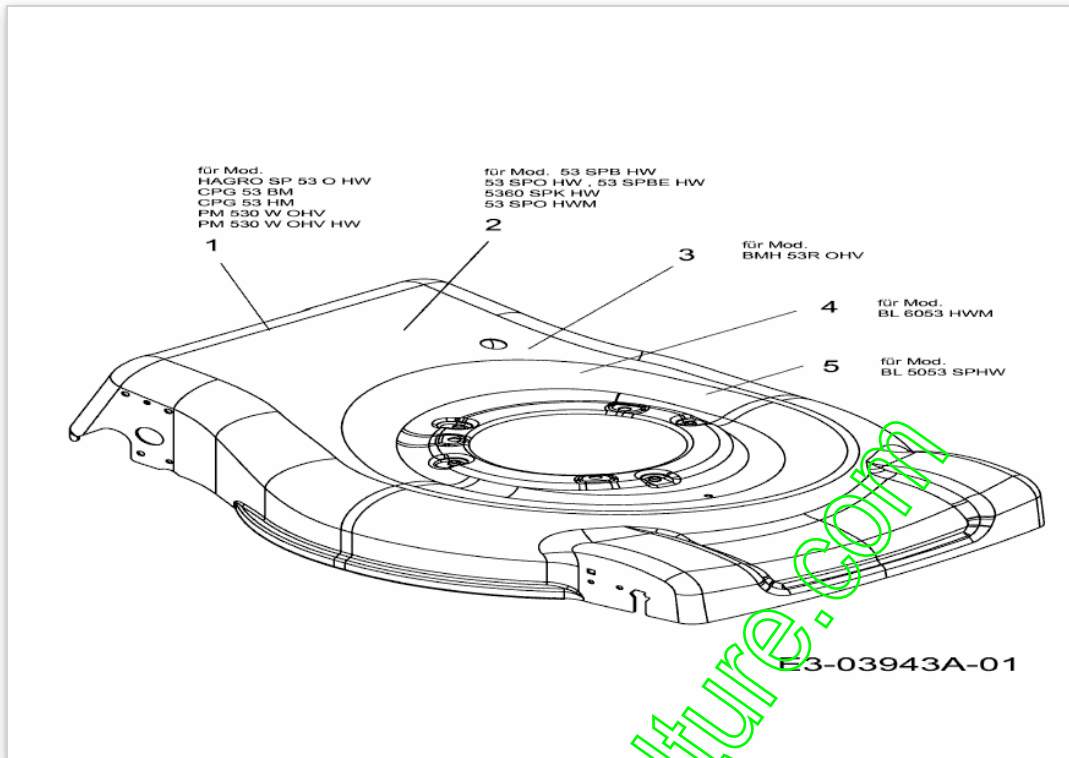

Position	Numéro de lapièce	#	Appellation I	Appellation II
1	787-01652668	1	CARTER 21"	MOOSGRÜN
2	787-01652638	1	CARTER 21"	MTD ROT
3	787-01652-TG	1	DECK:800:21"SP:CENTRAL:AUSWURF	TANNENGRÜN
4	787-01652691	1	COUV. DE PROT.:21":800	BLACK JACK
5	787-01652709	1	COUV. DE PROT.:21":800	MASTERCRAFT GRÜN

www.emc-motoculture.com

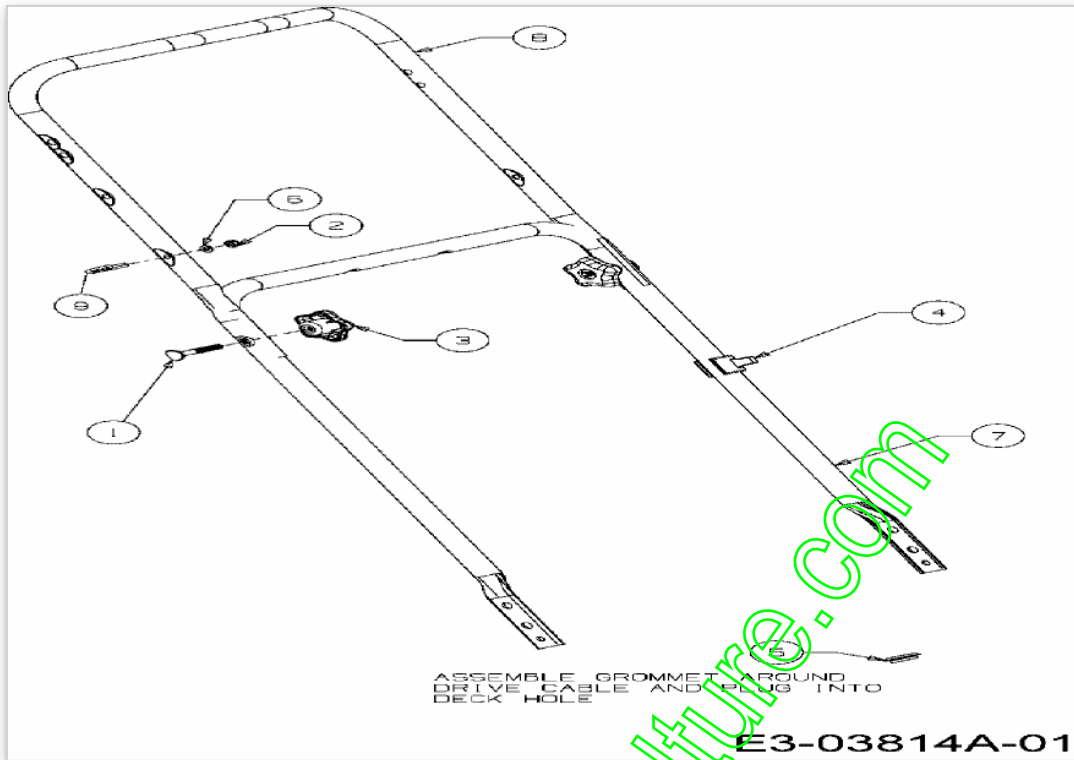

www.emc-motoculture.com

Position	Numéro de pièce	#	Appellation I	Appellation II
1	710-1174	2	VIS	FINISH:701-01000 910-1174
2	712-0691	1	ECROU HEXAGONAL	MTD SPEC-100015 24.1426.14
3	720-04072	2	POIGNÉE ÜTOILE	FINISH:NONE
4	731-2422	1	GUIDAGE DE CØBLE	FARBE:SCHWARZ
5	735-04059	1	JOINT D'ÜTANCHÜITÜ EN	FINISH:SCHWARZ
6	736-0668	1	RONDELLE	FINISH:MTD SPEC-100015
7	749-04037	1	BRANCARD INFERIEUR NOIR	749-04037
8	749-04453	1	BRANCARD SUPPERIEUR	FINISH:LACKIERT MTD ENGINE
9	782-7627A	1	GUIDE CORDE DE LANCEUR	GELBVERZINKT 000.02.621

www.emc-motoculture.com

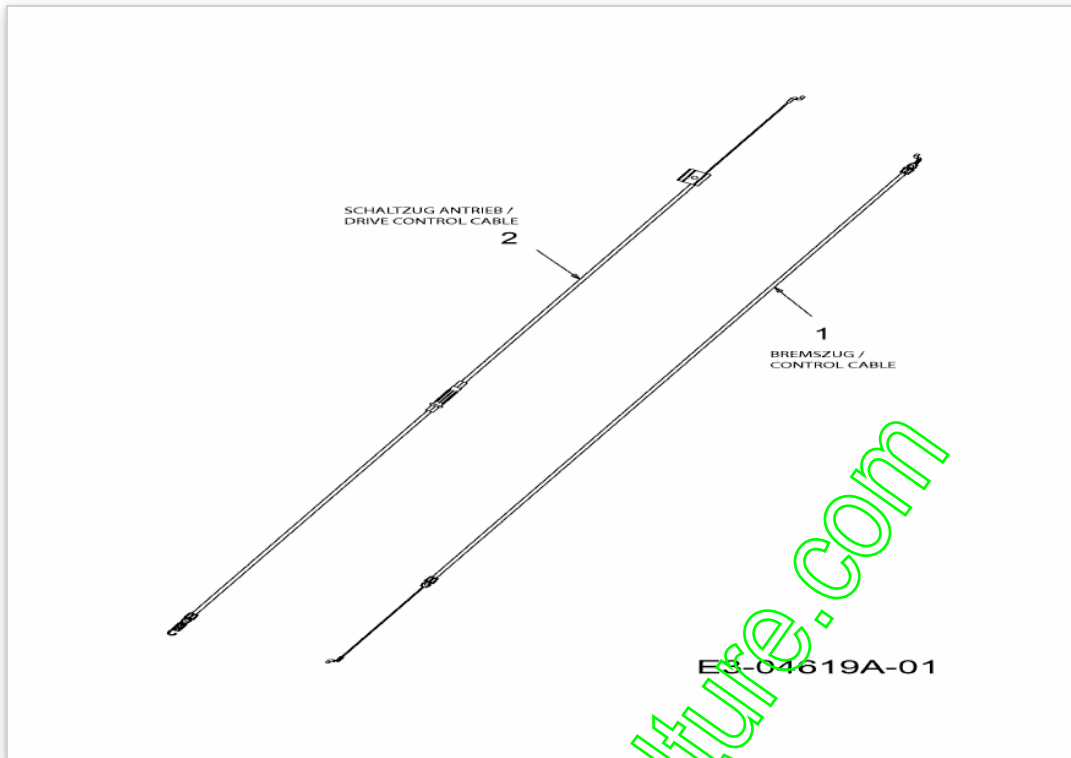

www.emc-motoculture.com

Position	Numéro de lapièce	#	Appellation I	Appellation II
1	746-04613	1	CABLE FREIN MOTEUR	746-04613
2	746-04620	1	CABLE TRACTION	746-04620

www.emc-motoculture.com

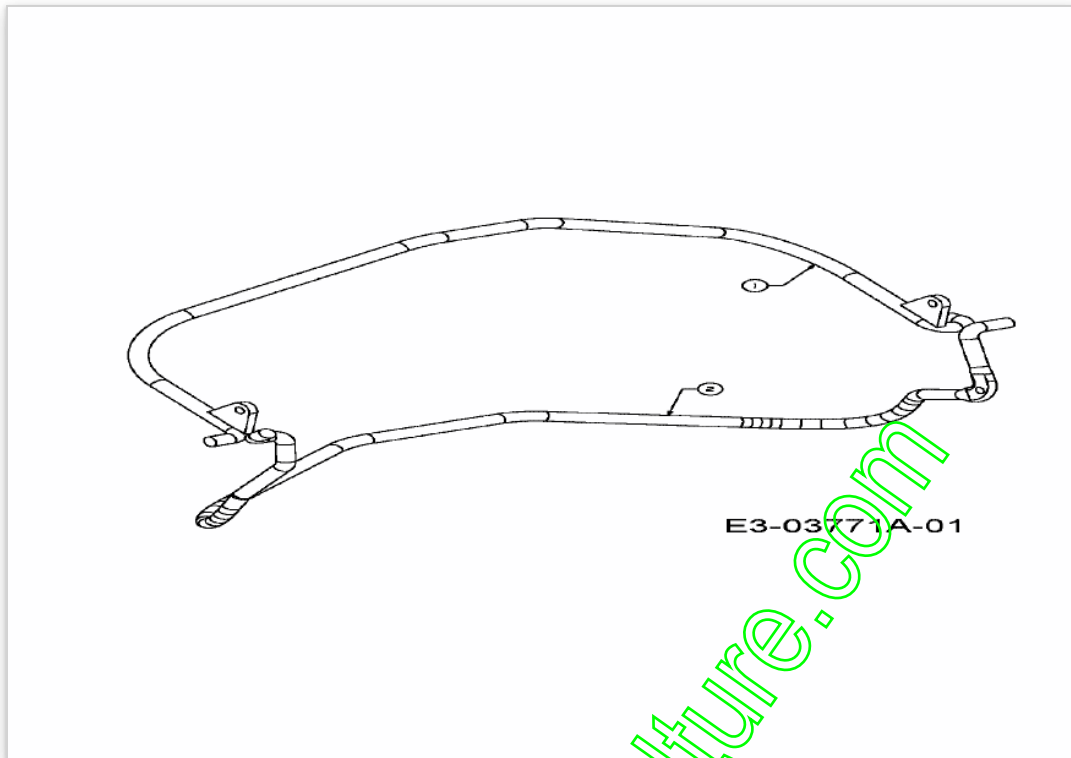

www.emc-motoculture.com

Position	Numéro de pièce	#	Appellation I	Appellation II
1	747-04118	1	ÜTRIER DE FREIN	747-04118
2	747-04498	1	ÜTRIER	GAS

www.emc-motoculture.com

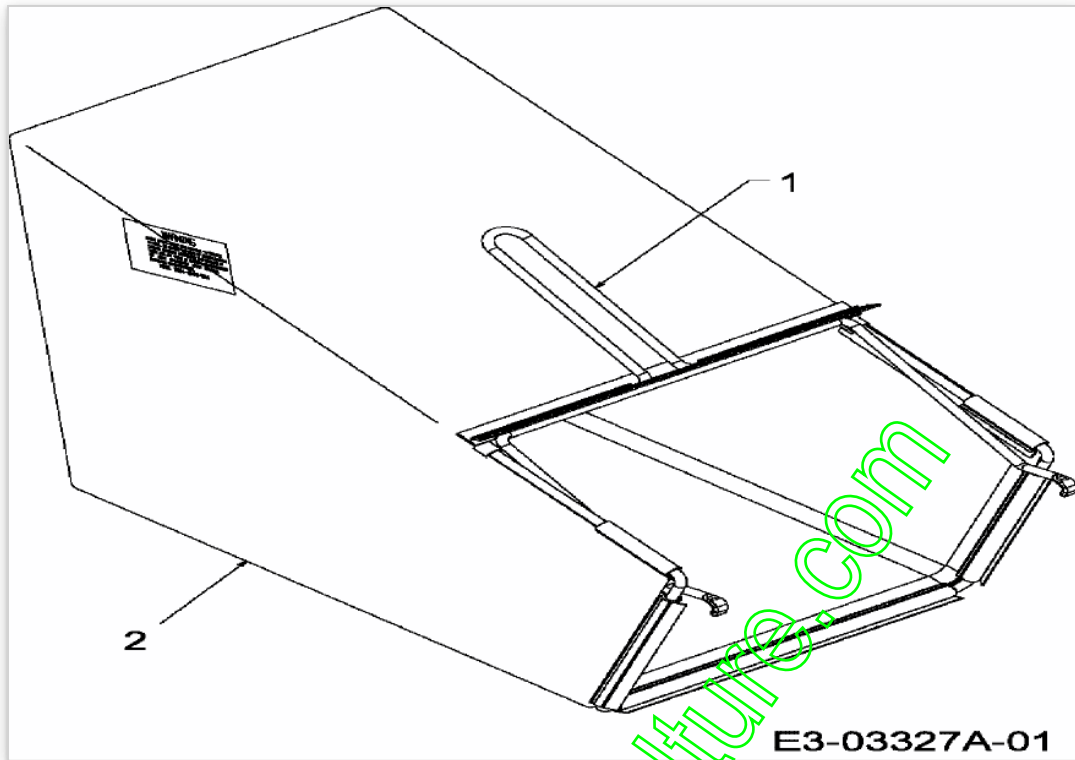

www.emc-motoculture.com

Position	Numéro de pièce	#	Appellation I	Appellation II
1	647-04051	1	CHASSIS SAC DE RAMASSAGE	647-04051-0637
2	664-04046A	1	TOILE SAC DE RAMASSAGE	664-04046A

www.emc-motoculture.com

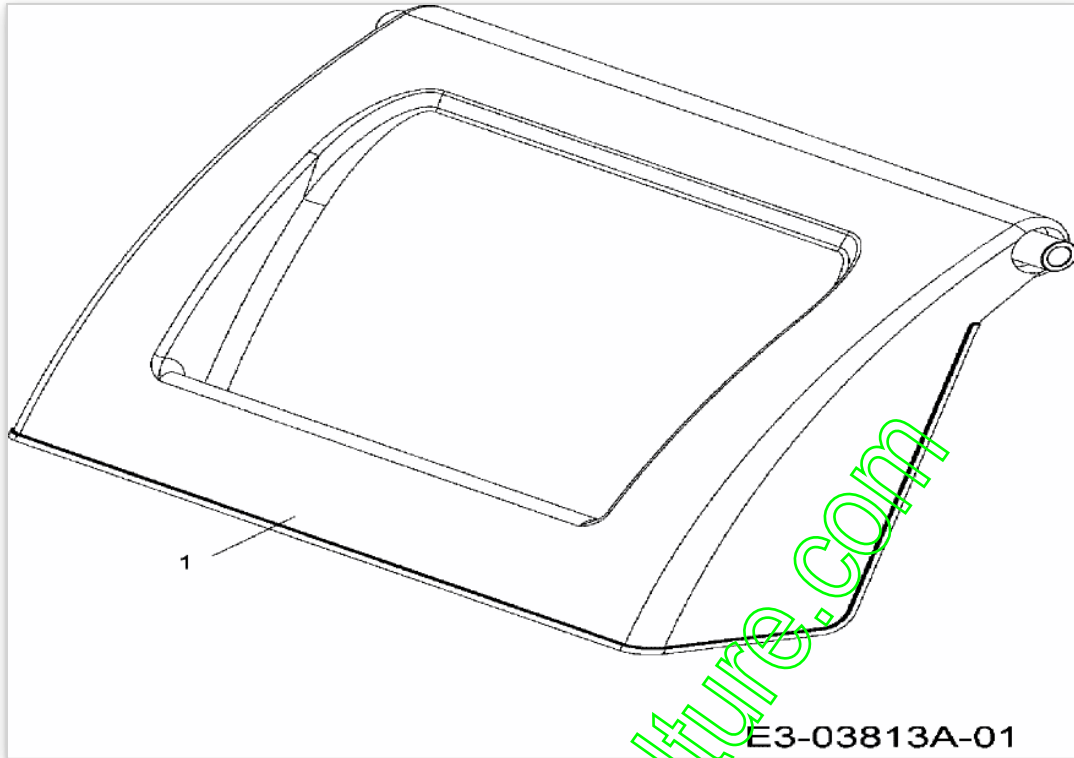

www.emc-motoculture.com

Position	Numéro de pièce	#	Appellation I	Appellation II
1	731-05017A	1	CLAPET ARRIERE	FINISH: SCHWARZ 931-05017A

www.emc-motoculture.com

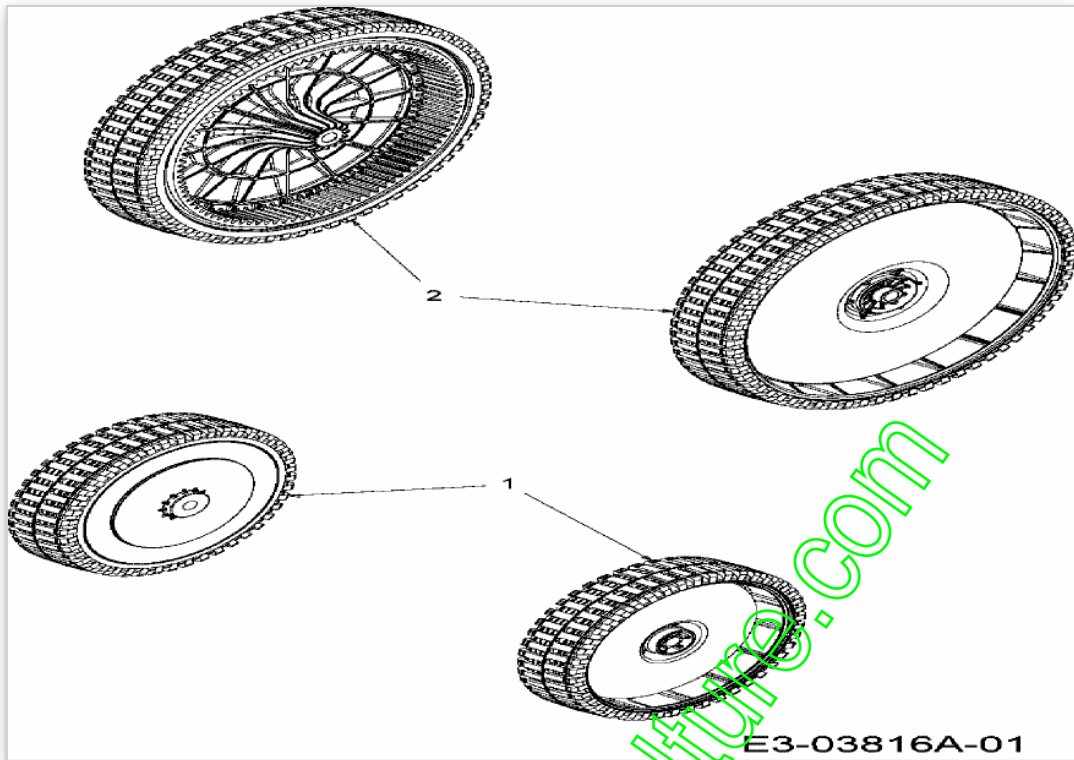

www.emc-motoculture.com

E3-03816A-01

Position	Numéro de lapièce	#	Appellation I	Appellation II
1	634-04408	2	ROUE AVANT 200 MM	FINISH
2	634-04412A	2	ROUE MOTRICE 300MM	634-04412A

www.emc-motoculture.com

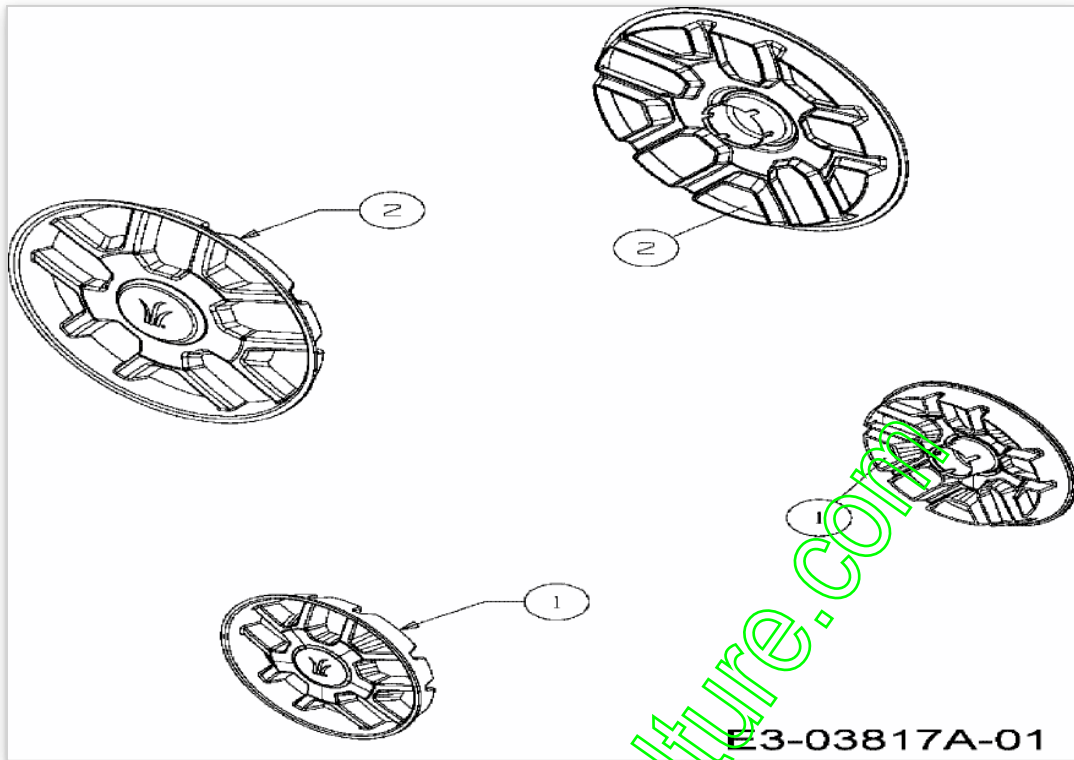

E3-03817A-01

Position	Numéro de lapièce	#	Appellation I	Appellation II
1	731-06224	2	ENJOLIVEUR	FINISH:OYSTER GRAY
2	731-06246	2	ENJOLIVEUR	OYSTERGRAU / MIT MTD-LOGO

www.emc-motoculture.com

www.emc-motoculture.com