

Position	Numéro de lapièce	Appellation I	Appellation II	Remarque
1	17932	SUPPORT RESERVOIR	STYLE-1	
2	17933A	SUPPORT TABLEAU DE BORD	17933A-0637	
3	710-0118	VIS	FINISH:PHOS & OIL	
5	710-0258	VIS	710-0258	
7	712-0267	ÛCROU HEXAGONAL	FINISH:MTD STD 701-01000	
8	725-0634	COMMUTATEUR	FINISH: SCHWARZ	
9	751-0603	BOUCHON RESERVOIR ESSENCE	FINISH:SCHWARZ	
10	726-0205	COLLIER DE SERRAGE DE BOYAU	FINISH:PHOS UND GELB LACKIERT	
11	726-0209	COLLIER	FINISH:SCHWARZ	
12	736-0119	RONDELLE	FINISH:MTD SPEC-100016	
13	725-0267	CONTACTEUR A CLE 5 FICHES	B.6PIN ERS.629-0234) 925-0267	
14	725-0201	CLE DE CONTACT	FINISH:VERNICK 17 079.12.707	
15	751-0553	RESERVOIR 5 L ENV.	FINISH:NATUR SIEHE ZG.	
16	751-0535-15	TUYAU / ESSENCE	751-0535-15 LANG	
17	761-0194	FREIN DE LAME	761-0194	
18	710-0134	VIS i TATE PLATE	FINISH:MTD SPEC-100015	
19	710-0793	VIS	710-0793	
20	783-0039	VOIR 783-0039A	783-0039	
21	783-0354	BAC DE SIËGE	40096/783-0354-0638	
22	17704	ÛQUERRE FIXATION SIËGE DROITE	17704-0637	
23	17703	ÛQUERRE DE FIXATION GAUCHE	17703-0637	
24	17553	PLAQUE D'EPaisseur DE COUPURE	VERZINKT	
25	725-1705	BATTERIE	150CCA:DRY	
26	710-0817	VIS HEXAGONALE	FINISH:MTD SPEC-701-01002	
27	725-1633	BATTERIE 12 V 14 AH	OHNE SÄURE	
28	710-0726	VIS 5/16 1200750:HXINDWS	FINISH:MTD STD 701-01002	
29	710-1017	VIS	FINISH:MTD SPEC-100016	
30	710-0870	VIS	710-0870 / 910-0870	
31	712-0287	ECROU HEXAGONAL 1/4- 20:GR2	FINISH:701-01000 / 912-0287	
33	783-0349	BOÏTIER DE BATTERIE	FINISH:LACKIERT SCHWARZ *	
34	732-0588	RESSORT DE PRESSION	732-0588	
35	731-0871B	BOITIER DE BATTERIE	731-0871B	
36	736-0242	RONDELLE CONIQUE.340X.872X.060	FINISH:MTD SPEC-100016	
37	736-0329	RONDELLE GROWER	FINISH:SPEC-100016 24.8195.16	
40	736-0270	RONDELLE GROWER	FINISH:MTD SPEC-100016	

Position	Numéro de pièce	Appellation I	Appellation II	Remarque
49	736-0217	RONDELLE GROWER	FINISH:MTD SPEC-100016	
50	712-0241	ECROU HEX.: 3/8-24:GR5	FINISH:MTD SPEC-100015	
53	725-0308B	TRITTBRETTAUFFAGE RECHTS	725-0308B	
54	725-0309C	TRITTBRETTAUFFAGE LINKS	725-0309C	
68	731-0511-81	GARNITURE	731-0511-81	
72	746-0616A	CABLE STARTER 58.4CM	746-0616A	
73	831-0823A	MANETTE GAZ AUTOPORTEE	931-0823A 400/700 o.Gaszug	
74	710-0779A	VIS	FINISH:701-01002 or 101615	
75	746-0776	CABLE ACCELERATEUR B&S	746-0776	
76	757-0345	SIEGE	8-7	dossier bas
76A	757-0338	SIEGE-DOSSIER MOYEN NOIR	10-5/957-0338	dossier medium
76B	757-0348	VOIR 757-0348A	757-0348	dossier hault
76C	757-0364	SIEGE INFERIEUR JAUNE	757-0364	dossier bas
76D	757-0365	SIEGE JAUNE YARDMAN	757-0365	dossier medium
78	736-0159	RONDELLE .349 X 88X.06"	FINISH:MTD SPEC-100015	
79	722-0160	RONDELLE D'ATTENUATION	722-0160	
83	710-0227	VIS	FINISH:MTD SPEC-100016 TYPE 1	
84	725-1439	RESSORT SURETE DE SIEGE	SI.-SCHALTER SITZ:SPEC-100015	
85	732-0581B	RESSORT DE TRACTION	732-0581B	
86	17239A	LEVIER / CONTACT	17239A	
87	726-0278	PLAQUE D'ISOLATION	FINISH:NATUR ODER SCHWARZ	
88	738-0155	VIS EPAULEE	FINISH:MTD SPEC-100015	
89	738-0296	AXE EPAULE	FINISH:SPEC-100015	
90	736-0141	RONDELLE	FINISH:MTD SPEC-100016	
91	710-0604	VIS HEX TT:5/16-18:0.62	FINISH:MTD SPEC-701-01006	
92	726-0279	PLAQUE D'ISOLATION	FINISH:NATUR ODER SCHWARZ	
94	723-0423	MARCHE PIED	Antirutschbelag	
95	725-1303	RESSORT DE SURETE SIEGE	SI.-SCHALTER SITZ:SPEC-100015	
96	731-1228	TABLEAU DE BORD	731-1228 ( mit Amp.M.+Lichts	avec ampermetre et contacteur lumière
96A	731-1502	TABLEAU DE BORD	731-1502 (ohne Amp.M.+Lichts	sans ampermetre et contacteur lumière
97	17782	CLIP: STARTER DE TRACTION	FINISH:VERZINKT	
102	725-0925	AMPEREMETRE ANGULEUX	725-0925	

Position	Numéro de pièce	Appellation I	Appellation II	Remarque
103	712-3007	ECROU HEX. 5/16-18 GR5	FINISH:MTD SPEC-100015	
104	710-0599	VIS A SIX PANS CREUX	FINISH:MTD SPEC-101617	
107	710-3015	VIS:1/4-20:.75:GR5:STD	FINISH:MTD SPEC-100015	
108	712-0271	ECROU 1/4-20"+ DISQUE DENTE	FINISH:MTD SPEC-100016 GR5	
111	723-0444	CEINTURE DE SECURITE BATTERIE	FINISH:SCHWARZ	
112	725-0689	BOUCHON BATTERIE	725-0689	
113	725-0690	BOUCHON DE BATTERIE	725-0690	fsg

[www.emc-motoculture.com](http://www.emc-motoculture.com)

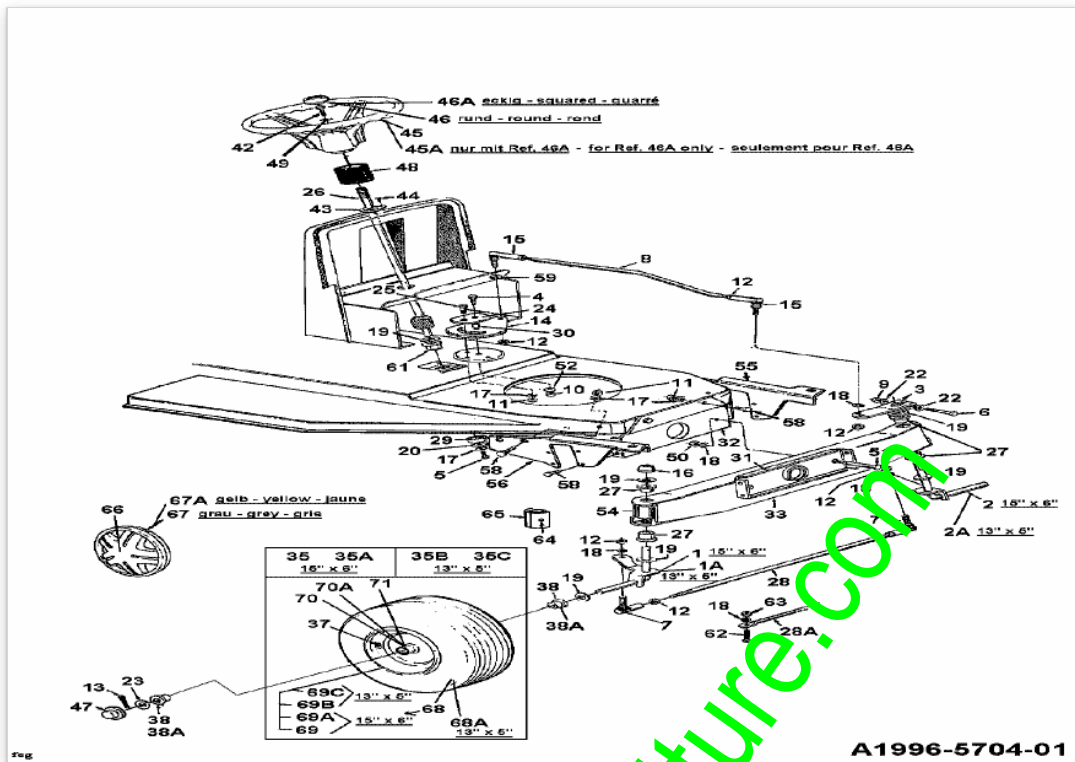

www.emc-motoculture.com

Position	Numéro de pièce	Appellation I	Appellation II	Remarque
1	17584A637	AXE AVANT DROIT	SCHWARZ GEPULVERT	15" x 6"
1A	683-0040A637	AXE DROIT 3.41 X 4.05		13" x 5"
2	17585A637	AXE AVANT GAUCHE NOIR	SCHWARZ GEPULVERT	15" x 6"
2A	683-0041A637	AXE AVANT GAUCHE	SCHWARZ GEPULVERT	13" x 5"
3	683-0055	LEVIER DIRECTION	683-0055/983-0055-0637	
4	710-0152	VIS HCCS:3/8-24:1.00:GR5:STD	910-0152	
5	710-0538	VIS HEX.:5/16-18:.625:GR.5:LOC	FINISH:701-01000	
6	710-0772	VIS HEX.:5/16-24X2.00	710-0772	
7	723-3018	ROTULE DE DIRECTION 3/8-24	FINISH:	
8	711-0838	TIGE	711-0838 E-TEIL-SET	
9	712-0237	ECROU EX.712-0305	FINISH:MTD SPEC-100015	
10	712-0241	ECROU HEX.: 3/8-24:GR5	FINISH:MTD SPEC-100015	
11	712-3010	ECROU HEX. 5/16-18:GR5	FINISH:MTD SPEC-100015	
12	712-0262	ECROU	FINISH:MTD SPEC-100015	
13	714-0470	EPINGLE EX AF-43010	FINISH:SPEC-100015 470 32 32	
14	717-0622A	SEGMENT DE DIRECTION	717-0622A	
15	723-3018	ROTULE DE DIRECTION 3/8-24	FINISH:	
16	726-0214	BOUCHON	FINISH:SCHWARZ	
17	736-0119	RONDELLE	FINISH:MTD SPEC-100016	
18	736-0169	BAGUE ÜLASTIQUE	FINISH:MTD SPEC-100016	
19	736-0187	RONDELLE .64X1.24X.06	FINISH:MTD SPEC-100016	
20	736-0343	RONDELLE .330 ID X 1.25 X .12	FINISH:MTD 701-100015	
22	736-0271	RONDELLE	HD:FINISH MTD SPEC-100016	
23	736-0285	RONDELLE .635 X 1.589 X .06	FINISH:MTD SPEC-100015	
24	17198A	PLAQUE	17198A	
25	738-0141	AXE		
26	738-0937	ARBRE DE DIRECTION	738-0937	
27	741-0659	BAGUE DE TRAVERSE AVANT	941-0659	
28	747-0753	KIT TRINGLE DIRECTION	E-TEIL-SET	ajustable
28A	747-0861	VOIR 747-0861-0637	747-0861-0637	non ajustable
29	750-0532	ENTRETOISE 980IDX1.250DX.0420		
30	750-0535	ENTRETOISE	FINISH:GEÖLT	
31	17548	SUPPORT	17548 SCHWARZ GEPULVERT	
32	17547	SUPPORT	17547	
33	683-0128	VOIR 683-0128-0637	683-0128-0637	
35	634-0087	ROUE COMPL 15 X 6,0	634-0087-0911/0662	15" x 6" avec roulement de plastique
35A	634-0091	ROUE COMPL	15 X 6	15" x 6" avec roulement à bille
35B	634-0097	ROUE COMPL 13" x 15"	634-0097-0662	13" x 5" avec roulement de plastique

Position	Numéro de pièce	Appellation I	Appellation II	Remarque
35C	634-0099	ROUE COMPL 13X5-6 COUSSINET	MIT CARLISLE REIFEN FELGE GRAU	13" x 5" avec roulement à bille
37	734-0255	VALVE:PNEU	TR 412-P / 32.6mm / 934-0255	
38	741-0487A	PALIER DE BRIDE	741-0487A (BR.748-0184)	Roulement de plastique
38A	741-0569	ROULEMENT DE ROUE AVANT	741-0569	Roulement à billes
42	710-0643	VIS HEX.: 5/16-18:1.00:GR5	FINISH:MTD SPEC-100015	
43	741-0501	PALIER DE BRIDE ARBRE DE DIREC	FINISH:KUNSTSTOFF SCHWARZ	
44	710-0837	VIS	FINISH:MTD SPEC-100016 TYPE 1	
45	731-1693	VOLANT 12" 3 RAYONS		seulement pour couvercle rond
45A	731-1687	VOLANT 3 RAYONS		seulement pour couvercle carré
46	731-0220	COUVERCLE / VOLANT	731-0220	
46A	731-1459	COUVERCLE BOUCHON /VOLANT	731-1459	quarrée
47	731-0484A	ENJOLIVEUR DEVANT	KUNSTSTOFF SCHWARZ 931-0484A	
48	731-0954	SOUFFLET GOMMEUX	731-0954	
49	736-0242	RONDELLE CONIQUE.340X.872X.0.60	FINISH:MTD SPEC-100016	
50	712-0431	ECROU STOP 3/8-16:GRF	FINISH:MTD SPEC-100015	
51	738-0527	BOULON	738-0527	
52	736-0356	RONDELLE	FINISH:MTD STD 701-01001	
54	731-1649	PALIER	PVC SCHWARZ: 450/500	
55	783-0255	SUSPENSION D'AXE GAUCHE	783-0255	
56	783-0256	SUSPENSION D'AXE DROITE	783-0256-0637	
58	710-0604	VIS HEX.TT:5/16-18:0.62	FINISH:MTD SPEC-701-01006	
59	736-0217	RONDELLE GROMMER	FINISH:MTD SPEC-100016	
61	741-0225	BAGUE HEXAGONALE TEFLON 6 PANS	FINISH:KUNSTSTOFF SCHWARZ	
62	710-0459	VIS	710-0459 / 910-0459	
63	712-0711	ECROU HEXAGONAL	MTD SPEC-100015 912-0711	
64	737-0280	GRAISSEUR	737-0280 / 937-0280	
65	731-1291A	GALTER PLASTIQUE	MATERIAL:PP SCHWARZ:LT5	
66	727-0425A	CLIP ENJOLIVEUR		
67	734-1613	ENJOLIVEUR AVANT GRIS	734-1613	
67A	734-1787	ENJOLIVEUR JAUNE VIF	734-1787	
68	734-0864	PNEU 15*600*6	Block TURF PRO	15" x 6"
68A	734-0298	PNEU 13*500*6	734-0298-0901/-0902 000.75.551	13" x 5"
69	634-0088	JANTE 6.0x4.5	634-0088-0662	15" x 6" avec roulement de plastique
69A	634-0090	JANTE	634-0090-0662	15" x 6" avec roulement à bille

Position	Numéro de lapièce	Appellation I	Appellation II	Remarque
69B	634-0096	JANTE	634-0096	13" x 5" avec roulement de plastique
69C	634-0098A	ZUSAMMENBAU:FELGE:KUGELLAGER:	6X3.87 GEBOHRT	13" x 5" avec roulement à bille
70	737-0211	GRAISSEUR	737-0211	15" x 6" avec roulement de plastique
70A	737-0280	GRAISSEUR	737-0280 / 937-0280	seulement pour modèle avec roulement à bille
71	737-0212	GRAISSEUR	737-0212	n`est pas utiliser dans 15" x 6" avec roulement à bille

[www.emc-motoculture.com](http://www.emc-motoculture.com)



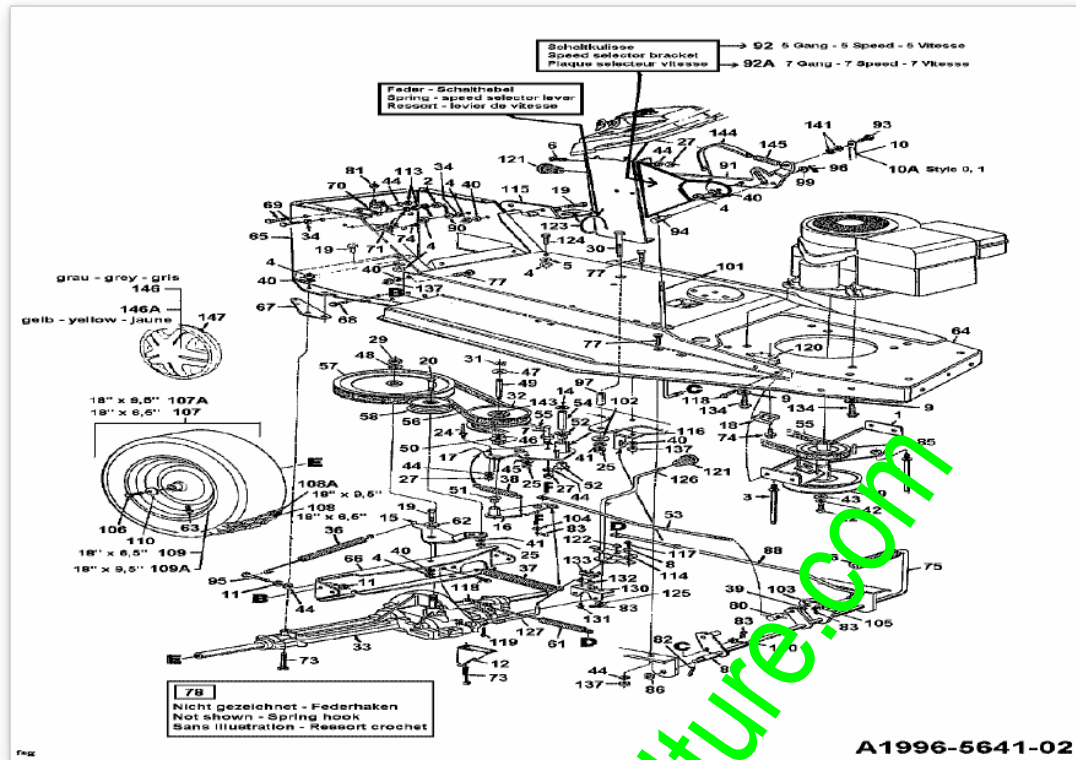

www.emc-motoculture.com

Position	Numéro de lapièce	Appellation I	Appellation II	Remarque
1	783-0265	TOLE DE PROTECTION	783-0265	
2	712-0291	ECROU EX AF-43013	FINISH:ASTM F1941 FE/ZN 3AN	
3	711-1044	BOULON	5/16-18X4.6 /911-1044	
4	712-0267	ÛCROU HEXAGONAL	FINISH:MTD STD 701-01000	
5	736-0242	RONDELLE CONIQUE.340X.872X.060	FINISH:MTD SPEC-100016	
6	710-0286	VIS	FINISH:701-01000	
7	711-1000	GUIDE COURROIE 25 X 3.0	FINISH: 911-1000	
8	736-0270	RONDELLE GROWER	FINISH:MTD SPEC-100016	
9	736-3072	RONDELLE .38 x.93 x.110:HT	FINISH:701-01001	
10	749-0820	TRINGLE	749-0820	
10A	749-0836	VOIR 749-0836A	749-0836	seulement pour style 0 et 1
11	712-0138	ECROU HEX. 1/4-28"	FINISH:MTD SPEC-100015	
12	17128A	SUPPORT EX.17128	17128A-0637	
14	736-0235	RONDELLE 3/8X1.26 X .172	FINISH:MTD STD 701-01000	
15	17694	SUPPORT	FINISH:SIEHE ZG.	
16	16554A	SUPPORT VARIATEUR	16554A-0637 / 16554A-Z	
17	16676A	SUPPORT ASS. EX 16676	16676A	
18	17962	PLAQUE DE SUPP. P. COMMUTATEUR	FINISH:WIE GESTANZT	
19	710-0118	VIS	FINISH:PHOS & OIL	
20	710-0151	VIS HEXAGONALE	FINISH:MTD SPEC-100015	
22	710-0757	VIS	FINISH:701-01000 910-0757	
24	711-0768	GUIDE DE COURROIE	711-0768	
25	712-0241	ECROU HEX. 3/8-24:GR5	FINISH:MTD SPEC-100015	
27	712-0287	ECROU HEXAGONAL 1/4- 20:GR2	FINISH:701-01000 / 912-0287	
29	712-3035	ECROU HEXAGONAL	FINISH:STD 701-01000 912-3035	
30	710-0902	VIS HCS:3/8- 24:375:GR5:STD	FINISH:MTD STD 701-01000	
31	716-0114	SIECLIPS	FINISH:PHOSPHATIERT DIN 471	
32	717-0800A	POULIE VARIATEUR DE VITESSE	917-0800A NADELLAGER 741-0404	
33	618-0166D	TRANSMISSION	HINTERACHSE	
34	736-0607	RONDELLE	FINISH:MTD SPEC-100016	
36	732-0384	RESSORT DE TRACTION	FINISH:SIEHE ZG.	
37	732-0459	RESSORT	FINISH:MTD STD 701-01000	
38	732-0568	RESSORT DE TRACTION	.50 OD X 2.54 LG	
39	736-0117	RONDELLE 3/8X.620X.033	FINISH:MTD SPEC-100015	
40	736-0119	RONDELLE	FINISH:MTD SPEC-100016	
41	736-0169	BAGUE ÛLASTIQUE	FINISH:MTD SPEC-100016	
42	736-0171	RONDELLE GROWER	FINISH:MTD SPEC-100016	

Position	Numéro de pièce	Appellation I	Appellation II	Remarque
43	736-0322	RONDELLE .450 X 1.250 X .164	FINISH:SPEC-100016 936-0322	
44	736-0329	RONDELLE GROWER	FINISH:SPEC-100016 24.8195.16	
45	736-0331	RONDELLE CONIQUE	FINISH:MTD SPEC-100016	
46	736-0355	RONDELLE	FINISH:701-01001	
47	736-0414	RONDELLE TÜFLON	FINISH:WEISS: 936-0414	
48	736-0427	RONDELLE	FINISH:MTD STD 701-01001	
49	738-0569	AXE DE VARIATEUR	738-0569	
50	741-0405	ENTRETOISE	.56 ID x 1.25 OD x .06/941-0405	
51	741-0419	SUPPORT DE BRIDE / DOUILLE	741-0419	
52	741-0495	BAGUE	FINISH:KUNSTSTOFF WEISS	
53	747-0599A	TRINGLE	747-0599A	
54	750-0703	ENTRETOISE 375IDX.625ODx1.54	750-0703	
55	754-0280	COURROIE MOTEUR/VARIATEUR	754-0280 / 954-0280	
56	754-0281	COURROIE VARIATEUR/BOITE	754-0281 / 954-0281	
57	656-0003	POULIE	656-0003 DURCHM.20,4CM	
58	756-0437	POULIE TENDEUR PLATE METAL	756-0437 / 956-0437	
59	756-0551	POULIE DOUBLE MOTEUR	756-0551 / E-TEIL-SET	
60	732-0303	RESSORT DE TRACTION	FINISH:PHOS & OIL	avant 1996
61	732-0413	RESSORT DE TRACTION	FINISH:PHOS & OIL	
62	748-0234	RONDELLE EPAULEE	FINISH:ROSTPREVENTION	
63	734-0255	VALVE:PNEU	TR 412-P / 32.6mm / 934-0255	
64	17588A	CHASSIS	'91	
65	783-0180A	CHASSIS / RIERE	400'96	
66	16654	SUPPORT DE TRANSMISSION	16654	
67	16659	RENFORT	16659-0637	
68	710-0726	VIS 5/16-12:0.750:HXINDWS	FINISH:MTD STD 701-01002	
69	710-0258	VIS	710-0258	
70	725-1426	RELAIS DE DEMARRAGE SOLENOID	725-1426 Mutter 712-0271	
71	725-0459	CONTACT VOIR 753-0685	725-0459	
72	736-0222	RONDELLE	FINISH:MTD SPEC-100016	
73	710-0176	VIS HEX.:5/16-18:2.75:GR5:STD	(21.1441.82)FINISH:SPEC-100015	
74	710-0351	VIS	FINISH:MTD SPEC-100016	
75	17644A	PEDALE D EMBRAYAGE ET FREINS	SCHWEIßTEIL:LACKIERT	
76	735-0239	CAOUTCHOUC/PEDALE 4;0 LG	FINISH:SCHWARZ	

Position	Numéro de pièce	Appellation I	Appellation II	Remarque
77	710-1012	VIS COTELEE: 5/16-24 x.87"LG	RD HD FINISH:PHOS & OIL	
78	732-0722	CROCHET DE RESSORT	732-0722	sans illustration
80	711-0198	FUSEAU D'ÛCROU	FINISH:MTD SPEC 701-01000	
81	712-0271	ECROU 1/4-20"+ DISQUE DENTE	FINISH:MTD SPEC-100016 GR5	
82	714-0470	EPINGLE EX AF-43010	FINISH:SPEC-100015 470 32 32	
83	714-0507	GOUPILLE FENDUE 3/32 X .750	FINISH:MTD SPEC-100015	
85	714-0114	CLAVETTE	FINISH:PLAIN	
86	736-0256	RONDELLE .635ID X 930 OD X.03	736-0256	
88	747-0593	TIGE DE FREIN	747-0593	
89	750-0800	ENTRETOISE	.640IDX.76ODX1.21	
90	725-0976A	CABLE DE MASSE	725-0976A	
91	17457B	LEVIER DE VITESSE	FINISH:VERZINKT SIEHE ZG.	
92	16693B	PLAQUE SELECTEUR 5 VITESSE	E-TELESET	
92A	16694B	PLAQUE / AJUSTEMENT 7 VITESSE		
93	738-0138	AXE	738-0138	
94	711-0677	FUSEAU D'ÛCROU - EX 711- 0611	FINISH:MTD SPEC-100015	
95	710-0428	VIS HEXAGONALE	FINISH:701-01000	
96	714-0104	GOUPILLE	FINISH:PHOS AND OIL	
97	750-0703	ENTRETOISE 375IDX.625ODx1.54	750-0703	
99	736-0264	RONDELLE: .230 x .630 x .0635	FINISH:SPEC-100015 936-0264	
100	736-0463	RONDELLE	FINISH:MTD SPEC-100015	
101	747-0675A	TIGE FILETEE	747-0675A	
102	736-0133	RONDELLE .411X1.25X1.00	FINISH:MTD SPEC-100015	
103	714-0115	GOUPILLE FENDUE 1/8 x 1.0	FINISH:MTD SPEC-100015	
104	736-0275	RONDELLE	FINISH:MTD SPEC-100015	
105	736-0278	RONDELLE	FINISH:MTD SPEC-100016	
106	710-0627	VIS HEX. 5/16-24:.750 GR5:LOCK	FINISH:MTD SPEC-100015	
107	734-0592	ROUE COMPL 18X6.50-8 ST	FINISH:SIEHE FARBVARIANTEN	
107A	734-0817	ROUE COMPL 18X9,50-8 ST ELEC	FINISH:SIEHE FARBVARIANTEN	
108	734-0294	PNEU 18*650 *8	SQ:SH:TS 734-0294-0901/902	
108A	734-0448	PNEU 18*950*8	TURF SAVER 734-0448-0901	
109	634-0069	JANTE 8.0 x 5.38 x 750 ID	634-0069-0662	18" x 6,50"
109A	634-0070	JANTE	FINISH:788-0499/674/0662	18" x 9,50"
110	736-0242	RONDELLE CONIQUE.340X.872X.060	FINISH:MTD SPEC-100016	

Position	Numéro de pièce	Appellation I	Appellation II	Remarque
113	712-0298	ECROU HEXAGONAL AF-43015	FINISH:MTD SPEC-100015	
114	17178A	PLAQUE D'AJUSTEMENT	17178A	
115	17839	SUPPORT	17839	
116	17597	SUPPORT DE TIGE DE FREIN	17597-Z	
117	710-0289	VIS	710-0289/910-0289	
118	710-0599	VIS A SIX PANS CREUX	FINISH:MTD SPEC-101617	
119	714-0149B	GOUPILLE FENDUE 1/2"	FINISH:MTD SPEC-701-01006	
120	725-1657A	SECURITE D'EMBRAYAGE	Sich.Mähwerk+Kuppl. GRAU	
121	720-0232	BOUTON DE LEVIER MANUEL	FINISH:KUNSTSTOFF SCHWARZ	
122	726-0231	CLIPS	726-0231	
123	732-0525	RESSORT DE RAPPEL LEVIER	FINISH:PRE-GALVANIZED	
124	710-0650	VIS HEX.:TT:5/16-18:0.875	FINISH:MTD SPEC-100016 TYPE 1	
125	736-0226	RONDELLE	FINISH:MTD SPEC-100015	
126	747-0694A	LEVIER EX 747-0694	FINISH:747-0694A-Z	
127	747-0685	LEVIER DE RACCORD	747-0685	
130	17179	SUPPORT	17179	
131	710-0227	VIS	FINISH:MTD SPEC-100016 TYPE 1	
132	726-0222	PLAQUE ISOLATEUR	726-0222	
133	725-0758	INTERRUPTEUR KIT 753-0580	725-0758	
134	710-0502A	VIS HEX. 3/8-16:1.250 LG.	SELBSTSCHN. SPEC / 701-01002	
135	710-0672	VIS HEX. 5/16-24:1.25:GR5:STD	FINISH:MTD SPEC-100015	
137	712-0123	ECROU HEXAGONAL	FINISH:701-01000	
141	736-0141	RONDELLE	FINISH:MTD SPEC-100016	
143	741-0404	ROULEMENT A AIGUILLE VARIATEUR.	741-0404/941-0404	
144	777-0404A	BANDE INDICATRICE 5 VITESSES	777-0404A	
144A	777-9586A	BANDE INDICATRICE 7 VITESSES	777-9586A	
145	732-0691	RESSORT	732-0691	
146	734-1615	ENJOLIVEUR ARR. GRIS	734-1615	
146A	734-1788	ENJOLIVEUR ARRIERE JAUNE	734-1788 (CLIP 727-0425A)	
147	727-0425A	CLIP ENJOLIVEUR		fsg

# 618-0166

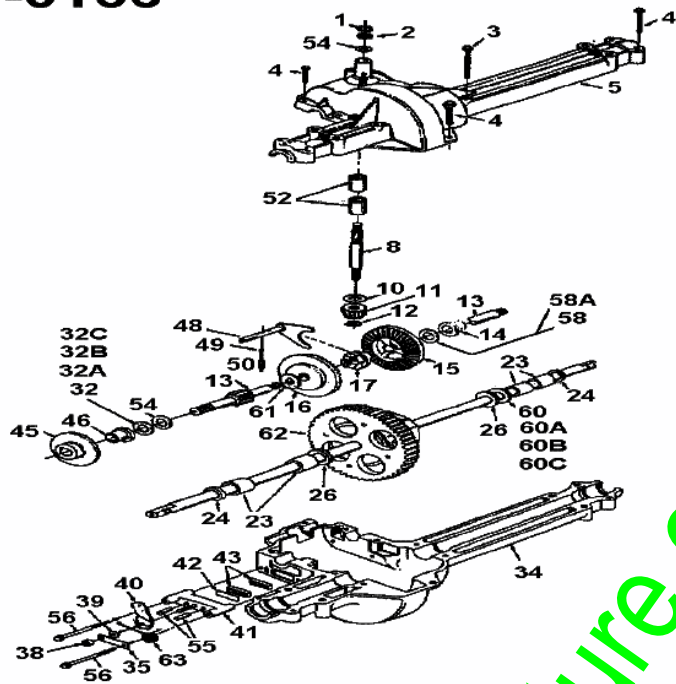

fsg

[www.emc-motoculture.com](http://www.emc-motoculture.com)

Position	Numéro de pièce	Appellation I	Appellation II	Remarque
1	732-0614	CIRCLIPS	FINISH:ZINC PHOSPHATE	
2	716-0231	CIRCLIPS	FINISH:SPEC-100016	
3	710-1026	VIS HEX:TT:1/4-20:1.750	FINISH:MTD-SPEC-100016	
4	710-0809	VIS HEX. TT:1/4-20:1.250:HXIND	FINISH:MTD SPEC-100016 TYPE 1	
5	719-0314	CARTER SUPÛRIEUR	719-0314	
8	711-0861	AXE	711-0861	
10	736-0335	RONDELLE 1 5/8XA1.25"X.06	FINISH:SIEHE ZG.	
11	717-0633	PIGNON 14 DENTS	717-0633/917-0633	
12	716-0171	CLIPS	SHR-62:FINISH PHOSPHATIERT	
13	711-1016	ARBRE D'ENTRAINEMENT FR.A G.	711-1016/911-1016	
14	741-0336	BAGUE	FINISH:SIEHE ZG. 941-0336	
15	717-1362	PIGNON CONIQUE 42 DENTS PT US	717-1362 / 917-1362 *	
16	717-1363	PIGNON CONIQUE 42 DENTS GR US	717-1363 / 917-1363 *	
17	718-0228	CRABOT	718-0228	
21	710-0862A	VIS	710-0862A	
23	741-0340	DOUILLE	ÖLUMRÄGNIERT EXXON 941-0340	
24	721-0338	JOINT	1.75 x 1.00 x .125:FINISH STD	
26	736-0445	RONDELLE	FINISH:MTD SPEC-100016	
32	736-0495	RONDELLE	FINISH:SIEHE ZG. 936-0495	
32A	736-0336	RONDELLE 5/8X1.00X.030	FINISH:MTD SPEC-100016	
32B	736-0494	RONDELLE	FINISH:MTD SPEC-100016	
32C	736-0337	RONDELLE 5/8 IDX1.0 ODX.040	MTD STD 701-01001 936-0337	
34	719-0313	CARTER INFÛRIEUR	719-0313/719-0313A	
35	718-0150	LANG. DE SUPP.: ANTI ROTATION	FINISH:SPEC-100015	
38	712-0273	ECROU HEXAGONAL 5/16-24"	FINISH:MTD SPEC-100015	
39	736-0371	RONDELLE 1.344XA .875"	FINISH:MTD SPEC-100016	
40	717-0772A	LEVIER DE FREIN	717-0772A	
41	761-0198	CARTER DE FREIN	FINISH:NONE	
42	717-0682	INSERT DE FREIN	FINISH:NONE 917-0682	
43	717-0678	PLAQUETTE DE FREIN	FINISH:	
45	761-0202	DISQUE DE FREIN	FINISH:ÖL UND FETTFREI	
46	741-0337	BAGUE	941-0337	
48	611-0011	FOURCHETTE	FINISH: 911-0011	
49	741-0862	BILLE	FINISH: SIEHE ZG.	
50	732-0863	RESSORT j PRESSION 225X.50"	FINISH: PHOS & OIL 932-0863	
52	741-0335	ROULEMENT 1,5/8X1/2" LG	FINISH:SIEHE ZG. 941-0335	
54	736-0349	RONDELLE 5/8 IDX10 OD X .020	FINISH:SIEHE ZG.	

Position	Numéro de pièce	Appellation I	Appellation II	Remarque
55	741-0343	GOUJON DE PRESSION 5/16"	FINISH:SIEHE ZG. 941-0343	
56	710-1206	VIS HEX. TT:1/4-20:2.375	FINISH:MTD SPEC-100016 TYPE 1	
57	717-1364	PIGNON DIFFÉRENTIEL 58 DENTS	717-1364 / E-TEIL-SET	
58	736-0349	RONDELLE 5/8 IDX10 OD X .020	FINISH:SIEHE ZG.	
58A	736-0495	RONDELLE	FINISH:SIEHE ZG. 936-0495	
60	736-0492	RONDELLE 76X1.5X.010	FINISH:MTD SPEC-100016	
60A	736-0493	RONDELLE 76X1.5X.020	FINISH:MTD SPEC-100016	
60B	736-0351	RONDELLE .75x1.50"	FINISH:MTD SPEC-100016	
60C	736-0445	RONDELLE	FINISH:MTD SPEC-100016	
61	736-0519	RONDELLE	FINISH:WET TUMBLE 936-0519	
62	618-0233	DIFFÉRENTIEL COMPLET	618-0233/918-0233	
63	732-0743	RESSORT	FINISH:ZINC PHOS&OIL 932-0743	
64	737-0148	GRAISSE		fsg

www.emc-motoculture.com



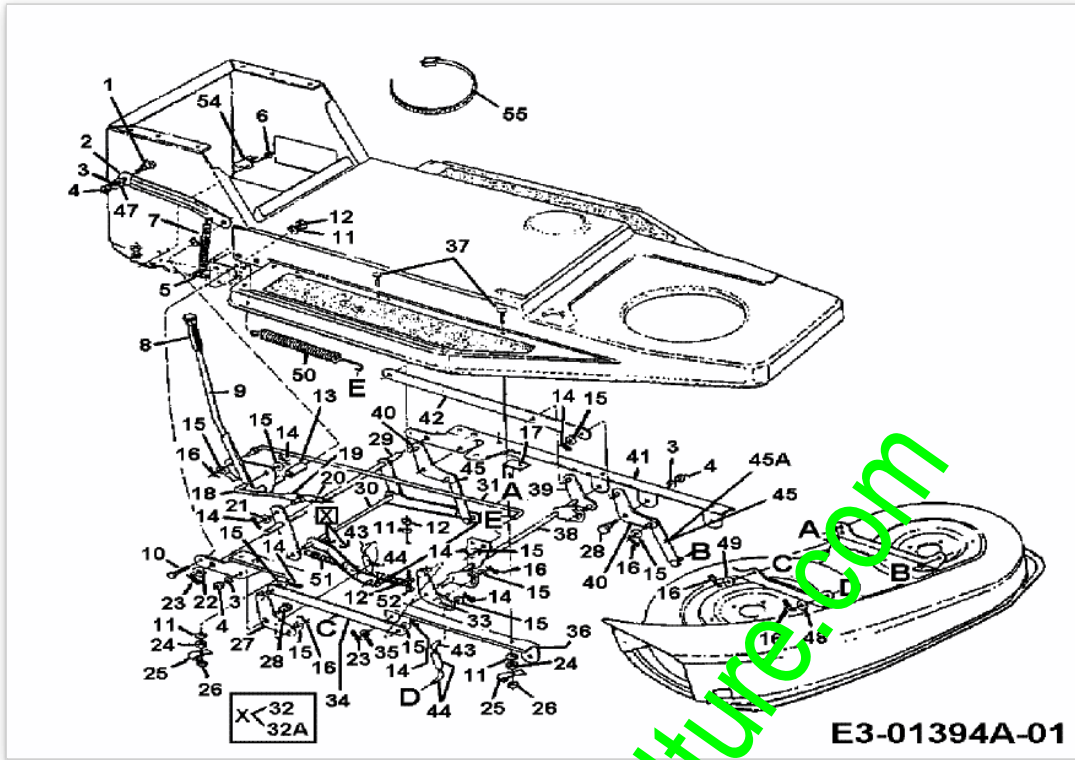

www.emc-motoculture.com

Position	Numéro de lapièce	#	Appellation I	Appellation II	Remarque
1	738-0143	1	VIS EPAULEE	FINISH:MTD SPEC 100015 (EU)	
2	17580	1	SUPPORT	17580-0637	
3	736-0169	1	BAGUE ÜLASTIQUE	FINISH:MTD SPEC-100016	
4	712-0798	1	ECROU HEXAGONAL	912-0798	
5	710-0428	1	VIS HEXAGONALE	FINISH:701-01000	
6	710-0351	1	VIS	FINISH:MTD SPEC-100016	
7	732-0640	1	RESSORT LEVIER RELEVAGE	FINISH:PHOS & OIL	
8	631-0026	1	POIGNÜE	631-0026 RB 731-2509 in USA	
9	17591A	1	LEVIER	FINISH:17591A-Z VERKÜRPPT	
10	710-0604	1	VIS HEX.TT:5/16-18:0.62	FINISH:MTD SPEC-701-01006	
11	736-0119	1	RONDELLE	FINISH:MTD SPEC-100016	
12	712-0267	1	ÜCROU HEXAGONAL	FINISH:MTD STD 701-01000	
13	750-0379	1	ENTRETOISE .647 IDX 780DX .85	750-0379	
14	714-0507	1	GOUPILLE FENDUE 3/32 X .750	FINISH:MTD SPEC-100015	
15	736-0185	1	RONDELLE 3/8.738X.063	FINISH:MTD SPEC-100015	
16	714-0104	1	GOUPILLE	FINISH:PHOS AND OIL	
17	17597	1	SUPPORT DE TIGE DE FREIN	17597-Z	
18	747-0746	1	TIGE FILETEE	FINISH:PHOS & OIL ODER ZINC	
19	16682P	1	DOUILLE DE GUIDAGE	16682P-0637	
20	712-0130	1	ECROU POLY STOP 3/8- 16" GR 8	FINISH:MTD SPEC-100015	
21	736-0314	1	RONDELLE	FINISH:MTD SPEC-100016	
22	736-0116	1	RONDELLE	FINISH:MTD SPEC-100015	
23	714-0470	1	EPINGLE EX AF-43010	FINISH:SPEC-100015 470 32 32	
24	712-0123	1	ÜCROU HEXAGONAL	FINISH:701-01000	
25	726-0272	1	COLNIER	FINISH:MTD SPEC-100015	
26	712-0237	1	ECROU EX.712-0305	FINISH:MTD SPEC-100015	
27	17555	1	BOUR 97555	17555-0637	
28	738-0281	1	VIS ÜPAULE:.625 X.17:3/8-16	FINISH:SPEC-100015 938-0281	
29	17574	1	ARBRE	17574-0637 SCHWEIßTEIL	
30	738-0667	1	AXE	E-TEIL-SET	
31	747-0745	1	LEVIER	17.8 LG FINISH:SIEHE ZG	
32	17573A637	1	PLAQUE STABILISATEUR	SCHWARZ GEPULVERT	trapézoidal
32A	783-0281637	1	PLAQUE STABILISATEUR PLATEAU	SCHWARZ GEPULVERT	rectangulaire
33	17554	1	SUPPORT	17554-0637	
34	17563	1	FERRURE D	17563-0637	
35	736-0336	1	RONDELLE 5/8X1.00X.030	FINISH:MTD SPEC-100016	
36	17582	1	SUPPORT	17582-0637	

Position	Numéro de pièce	#	Appellation I	Appellation II	Remarque
37	710-1012	1	VIS COTELEE: 5/16-24 x.87"LG	RD HD FINISH:PHOS & OIL	
38	17568	1	SUPPORT &&&	17568	
39	17557	1	SUPPORT GAUCHE	17557-0637	
40	17556	1	SUPPORT		
41	17581	1	SUPPORT	17581-0637	
42	17562	1	FERRURE G	17562-0637	
43	747-0584	1	ETRIER 38x 1,25 x LG	747-0584	
44	97709	1	MOLLETTE DE REGLAGE EX 17709	97709/17709	
45	97598	1	ÜCLISSE DE SUSPENSION	97598	seulement pour plateau de coupe A et C
45A	683-0111	1	ECLISSE DE JONCTION COMPL	.88 X3.31 LG	pour plateau de coupe D,E,F
47	736-0192	1	RONDELLE .531 X 93 X .090	FINISH:MTD SPEC-100015	
48	736-0185	1	RONDELLE 3/8.738X.063	FINISH:MTD SPEC-100015	
49	736-0101	1	RONDELLE	FINISH:MTD SPEC-100015	
50	732-0638	1	RESSORT	FINISH:PHOS & OIL 32cm	
51	732-0603	1	RESSORT	FINISH:PHOS & OIL	
52	710-3038	1	VIS HHCS:5/16- 18:.875:GR5:STD	FINISH:701-01000	
54	17962	1	PLAQUE DE SUPP. P. COMMUTATEUR	FINISH:WIE GESTANZT	
55	725-0157	1	COLLIER DE SERRAGE3/16X0.5X7.4	MATERIAL:NYLON-SCHWARZ	

www.emc-motoculture.com

Deck "E"

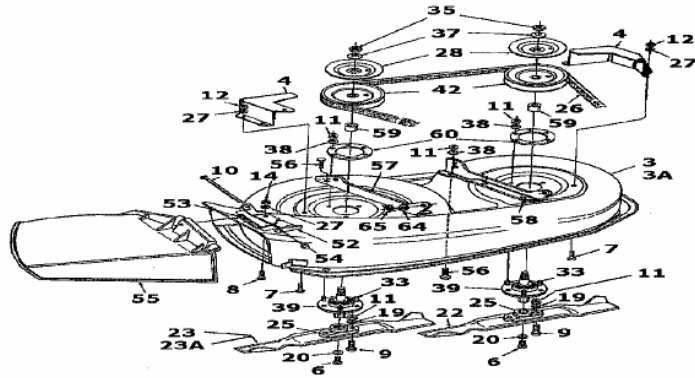

[www.emc-motoculture.com](http://www.emc-motoculture.com)

Position	Numéro de lapièce	Appellation I	Appellation II	Remarque
3	16879A	CARTER	16879A	
3A	813-04130	36"E PLATEAU ASM EXP.		
4	683-0095	PROTECTION COURROIE	683-0095-0637	
6	710-1039	VIS	FINISH:MTD SPEC-100015	
7	710-0599	VIS A SIX PANS CREUX	FINISH:MTD SPEC-101617	
8	710-0258	VIS	710-0258	
9	710-0888	VIS HEXAGONAL	5/16-24X1.00	
10	711-0792	GOUJON	MTD SPEC-100015 911-0792	
11	712-0123	ÛCROU HEXAGONAL	FINISH:701-01000	
12	712-0138	ECROU HEX. 1/4-28"	FINISH:MTD SPEC-100015	
14	712-0287	ECROU HEXAGONAL 1/4-20:GR2	FINISH:701-01000 / 912-0287	
19	736-0119	RONDELLE	FINISH:MTD SPEC-100016	
20	736-0217	RONDELLE GROWER	FINISH:MTD SPEC-100016	
22	742-0496	LAME COUPE 92CM LATERALE	742-0496/942-0496	
23	742-0496	LAME COUPE 92CM LATERALE	742-0496/942-0496	
23A	742-0507A	LAME EXTRA-SFF COUPE 92CM LAT	742-0507A/942-0507A	seulement en position d'éjection
25	748-0300	SUPPORT DE LAME 3T AUTOPORTEES	748-0300	
26	754-0364	COURROIE DEV LAME COUPE 91CM	754-0364/954-0364	
27	736-0270	RONDELLE GROWER	FINISH:MTD SPEC-100016	
28	09322	DISQUE DE FREIN	VERZINKT	
33	710-1012	VIS COTELEE: 5/16-24 x.87"LG	RD HD FINISH:PHOS & OIL	
35	712-0318	ECROU	712-0318	
37	736-0158	RONDELLI GROWER	FINISH:MTD STD 701-01001	
38	736-0242	RONDELLE CONIQUE 3/40X.872X.060	FINISH:MTD SPEC-100016	
39	717-0900	VOIR 717-0900A	717-0900	
42	756-0486	POULE DE COURROIE R.PÜZ.	756-0486	
52	703-1693	PLAQUE DE RACCORDEMENT	703-1693	
53	732-0602	RESSORT	732-0602 / 932-0602	
54	726-0106	COUVERCLE 1/4 "	FINISH:MTD SPEC-100016	
55	731-1032	CLAPET D'ÛJECTION	731-1032	
56	710-0157	VIS HEX.:5/16-24.:75 GR5 STD	FINISH:701-01000	
57	17572	BRIDE	FINISH:17572-0637	
58	17571	BRIDE	17571-0637	
59	750-0456	ENTRETOISE	FINISH:GEÖLT	
60	09164A	PLAQUE DE RENFORT	FINISH:	
64	736-0185	RONDELLE 3/8.738X.063	FINISH:MTD SPEC-100015	

Position	Numéro de lapièce	Appellation I	Appellation II	Remarque
65	714-0104	GOUPILLE	FINISH:PHOS AND OIL	fsg

[www.emc-motoculture.com](http://www.emc-motoculture.com)

**717-0900A**

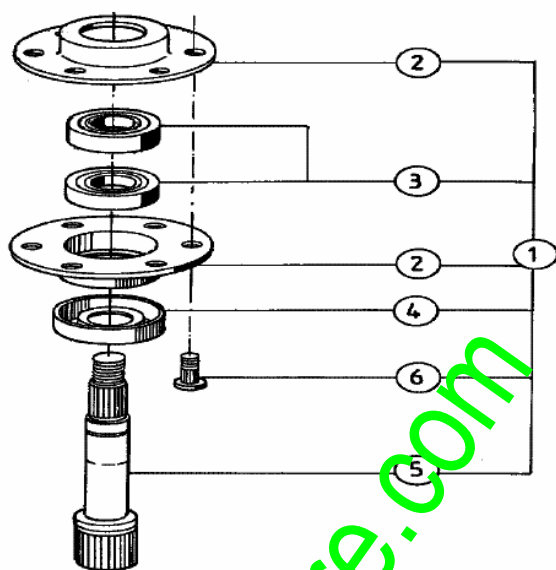

**E3-01272A-01**

[www.emc-motoculture.com](http://www.emc-motoculture.com)

Position	Numéro de pièce	#	Appellation I	Appellation II
1	717-0900A	1	PALIER LAME COMPLET 81/92CM	32/36 917-0900A
2	08253B	2	COUPELLE INFERIEURE	FINISH:VERZINKT SIEHE ZG.
3	741-0919	2	ROULEMENT j BILLES	FINISH:SIEHE SPEC.
4	13703	1	RONDELLE	FINISH:PHOSPATE & OIL
5	738-0707A	1	AXE PALIERS 717-0900A/717-0906	
6	710-1012	3	VIS COTELEE: 5/16-24 x.87"LG	RD HD FINISH:PHOS & OIL

[www.emc-motoculture.com](http://www.emc-motoculture.com)



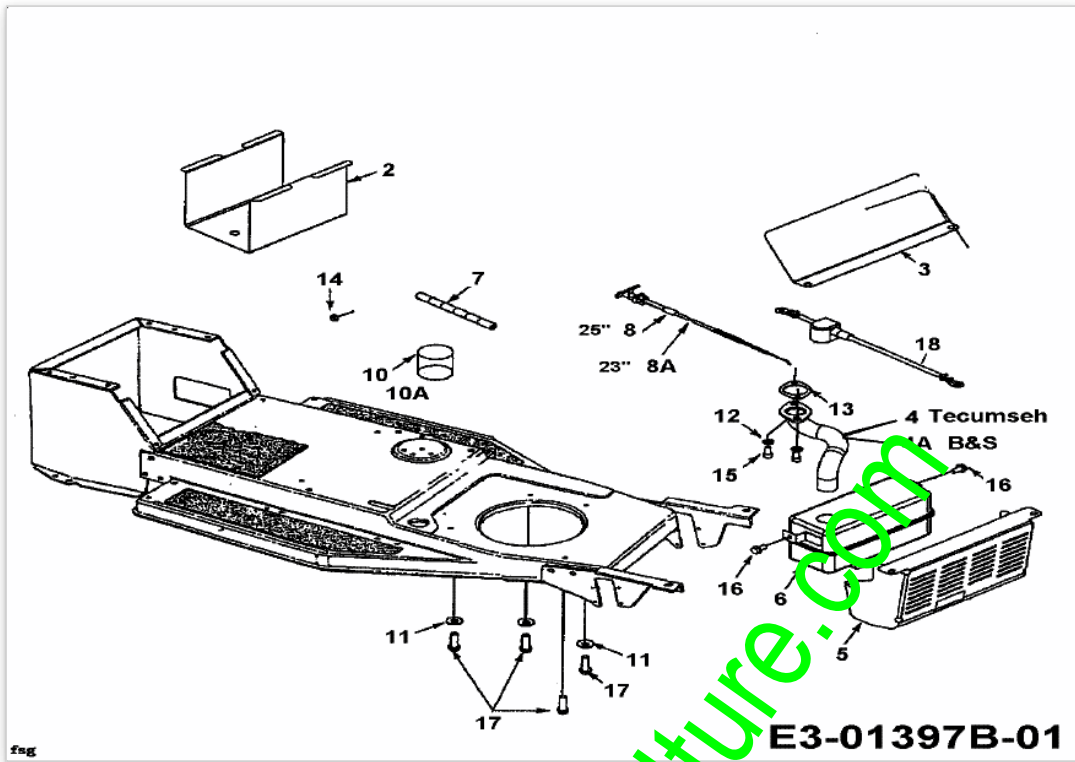

Position	Numéro de pièce	#	Appellation I	Appellation II	Remarque
2	783-0349	1	BOÎTIER DE BATTERIE	FINISH:LACKIERT SCHWARZ *	
3	751-0642	1	PROTECTION CHALEUR	751-0642	
4	751-0640	1	COLLECTEUR	751-0640	pour moteurs Tecumseh
4A	751-0628	1	TUYAU D'ÛCHAPPEMENT B&S OHV400	751-0628	Moteurs à essence Briggs&Stratton
5	751-0631A637	1	PROTECTION DE CHALEUR	SCHWARZ GEPULVERT	
6	751-0627	1	ÛCHAPPEMENT OHV 400	751-0627	
7	751-0535-MET	1	TUYAU D'ESSENCE (PAR METRE)	Beschaf.751-0535(Acht incl. x50)	
8	746-3026	1	CABLE 25,0 LG	746-3026	
8A	746-0616A	1	CABLE STARTER 58.4CM	746-0616A	
10	000.40.520	1	HUILE	(OEM-737-0295=1.4L-0208=0.6L)	
10A	OEM737-0295B	1	HUILE MOTEUR SAE30 1.4 Litres	HD 30 (WESTEUROPA)	
11	736-3072	3	RONDELLE .38 x.93 x.110:HT	FINISH:701-01001	
12	736-0119	2	RONDELLE	FINISH:MTD SPEC-100016	
13	721-0208	1	JOINT ECHAP B/S MONO CYLINDRE	FINISH:B&S #272293	
14	712-0271	1	ECROU 1/4-20"+ DISQUE DENTE	FINISH:MTD SPEC-100016 GR5	
15	710-1314	2	VIS 5/16-18;625	710-1314	
16	710-0604A	2	VIS 5/16-18;0.625	FINISH:MTD SPEC-100016 TYPE 1	
17	710-0502A	4	VIS HEX 3/8-16:1.250 LG	SELBSTSCHN. SPEC / 701-01002	
18	629-0705	1	CABLE BATTERIE ROUGE 356MM	GUMMISCHUTZKAPPE GROSS ROT	

www.emc-motoculture.com

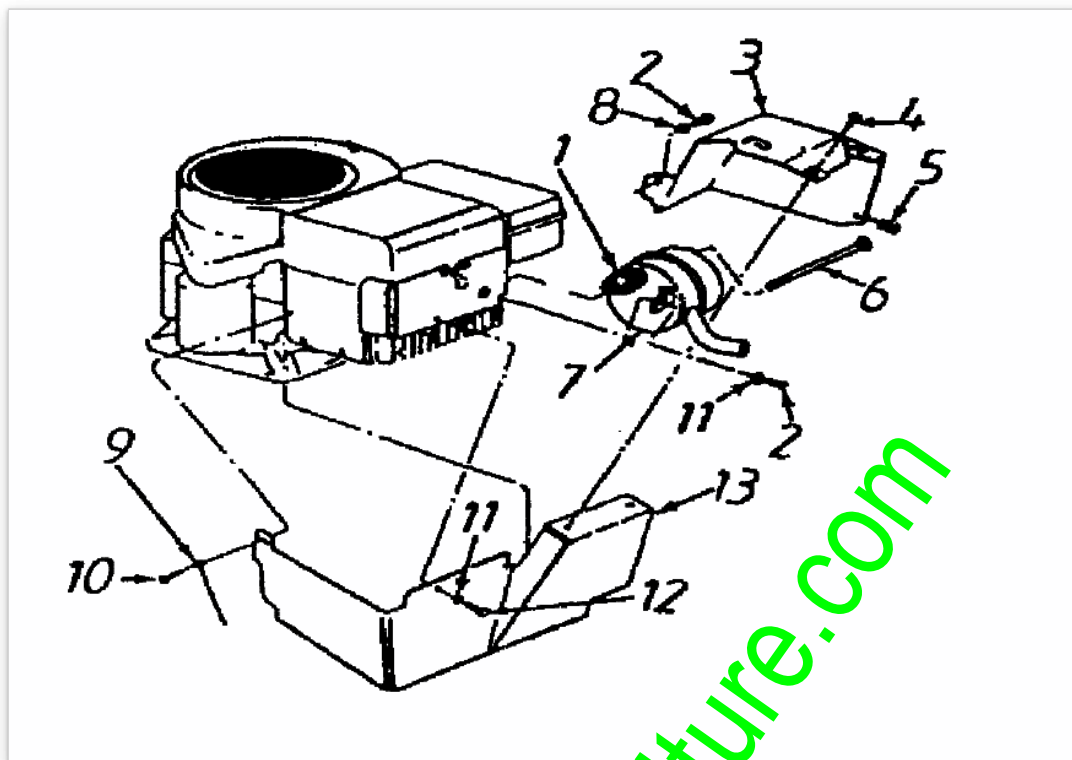

[www.emc-motoculture.com](http://www.emc-motoculture.com)

Position	Numéro de pièce	Appellation I	Appellation II	Remarque
1	721-0208	JOINT ECHAP B/S MONO CYLINDRE	FINISH:B&S #272293	
2	710-0599	VIS A SIX PANS CREUX	FINISH:MTD SPEC-101617	
3	683-0042A	AUTOCOLLANT PROTECTION	683-0042A-0637	
4	710-0429	VIS	910-0429	
5	712-0147	ECROU 10-24 U-TYPE	FINISH:PLAIN	
6	738-0636	AXE	7/16ODx3.56x5/16	
7	751-0465A	ECHAPPEMENT	5":B&S	
8	736-0329	RONDELLE GROWER	FINISH:SPEC-100016 24.8195.16	
9	725-0976A	CABLE DE MASSE	725-0976A	
10	710-0323	VIS	FINISH:701-01000	
11	736-0175	RONDELLE GROWER:.265x.562x.025	FINISH:701-01000	
12	710-0294	VIS	710-0294	
13	16936	PROTECTION CHALEUR AVANT	16936	fsg

[www.emc-motoculture.com](http://www.emc-motoculture.com)

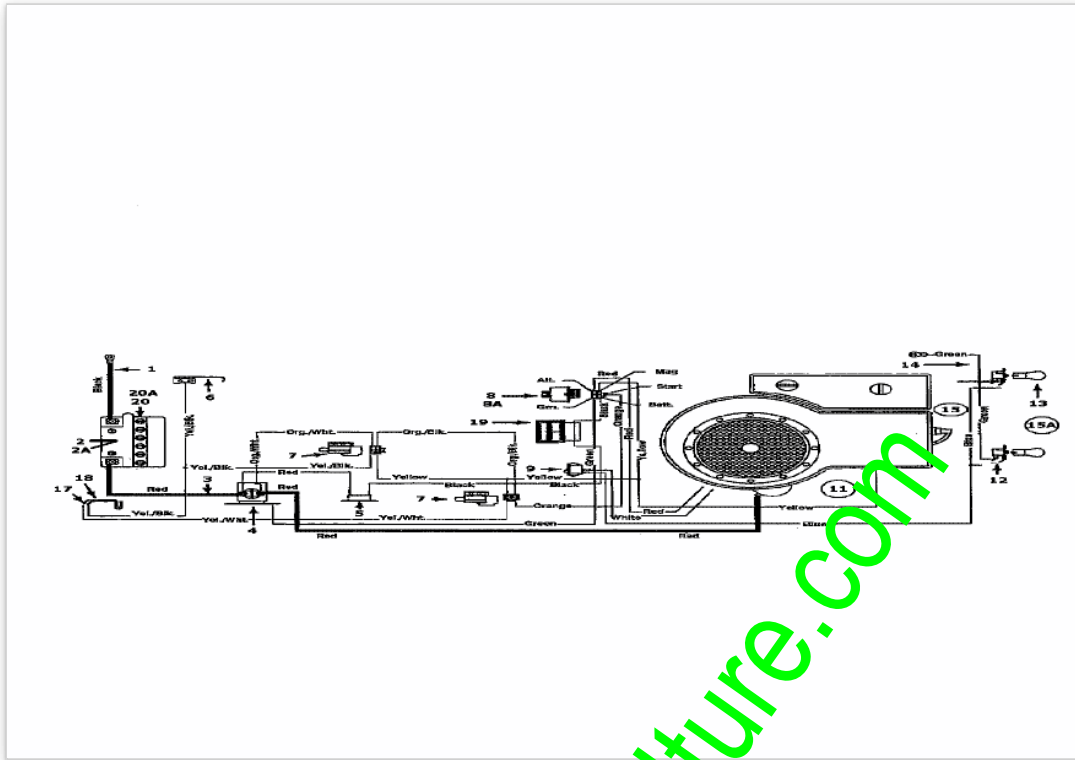

www.emc-motoculture.com

Position	Numéro de pièce	Appellation I	Appellation II	Remarque
1	725-0976A	CABLE DE MASSE	725-0976A	
2	725-1705	BATTERIE	150CCA:DRY	
2A	725-1633	BATTERIE 12 V 14 AH	OHNE SÄURE	
3	725-1351	CABLE 8 x 8 LG	725-1351 RB 725-0926	
4	725-1426	RELAIS DE DEMARRAGE SOLENOID	725-1426 Mutter 712-0271	
5	725-0459	CONTACT VOIR 753-0685	725-0459	
6	732-1644	7504132	732-1644 siehe 725-1644	
7	725-1657A	SECURITE D'EMBRAYAGE	Sich.Mähwerk+Kuppl. GRAU	
8	725-0267	CONTACTEUR A CLE 5 FICHES	B.6PIN ERS.629-0234) 925-0267	
8A	725-0201	CLE DE CONTACT	FINISH:VERNICKELT 078-12.707	
9	725-0634	COMMUTATEUR	FINISH: SCHWARZ	
11	629-0195	FAISCEAU	629-0195	
12	725-1651	PORTE AMPOULE	925-1651	
13	725-0963	AMPOULE ELECTRIQUE	FINISH:	
14	725-0916A	CABLE	725-0916A	
15	629-0084	CABLE ALLUMAGE	629-0084	avec ampermetre et contacteur lumière
15A	629-0103	TUBE POUR INTERRUPTEUR PHARE	629-0103	sans ampermetre et contacteur lumière
17	725-1303	RESSORT DE SURETE SIÈGE	SI.-SCHALTER SITZ:SPEC-100015	
18	725-1439	RESSORT SURETE DE SIEGE	SI.-SCHALTER SITZ:SPEC-100015	
19	725-0925	AMPEREMETRE ANGULEUX	725-0925	
20	725-0690	BOUCHON DE BATTERIE	725-0690	seulement pour batterie 725-1633
20A	725-0689	BOUCHON BATTERIE	725-0689	seulement pour batterie 725-1705

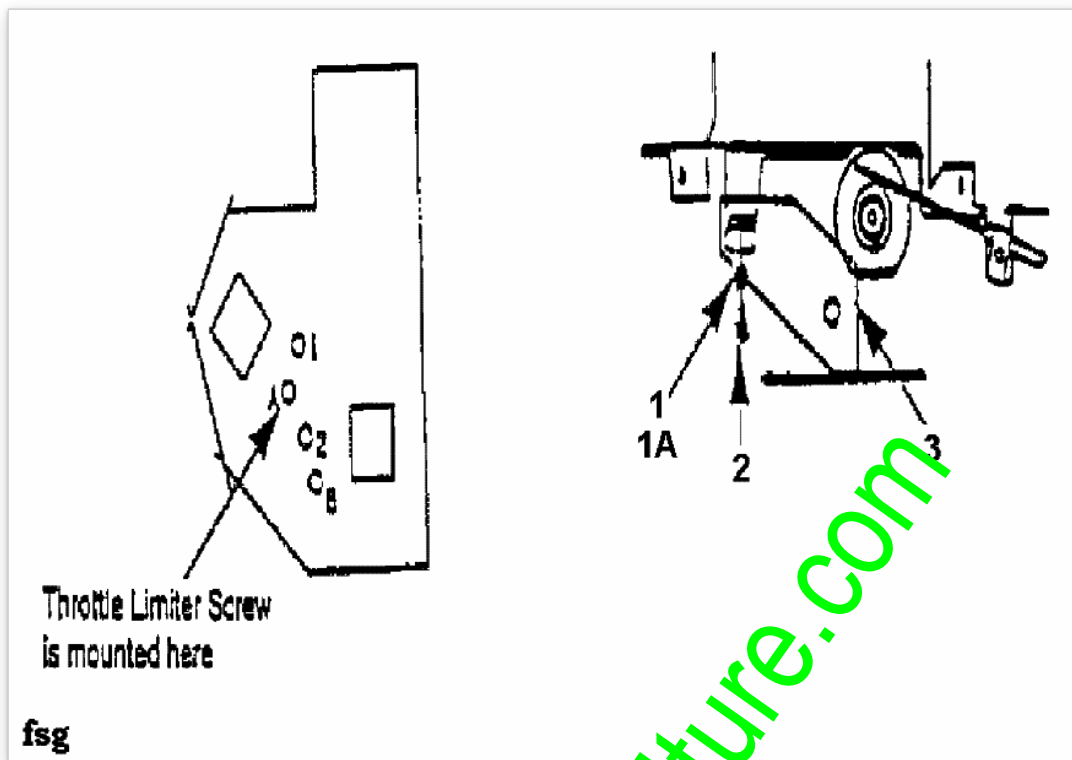

Position	Numéro de pièce	Appellation I	Appellation II
1	736-0400	RONDELLE PLATE .194x.62x.063	FINISH:MTD SPEC-100015
1A	710-0456	VIS	FINISH:701-01002
2	710-0899A	VIS HEXAGONALE	FINISH:MTD SPEC-100016
3	17483	SUPPORT	17483

[www.emc-motoculture.com](http://www.emc-motoculture.com)



### Models 450 and 470

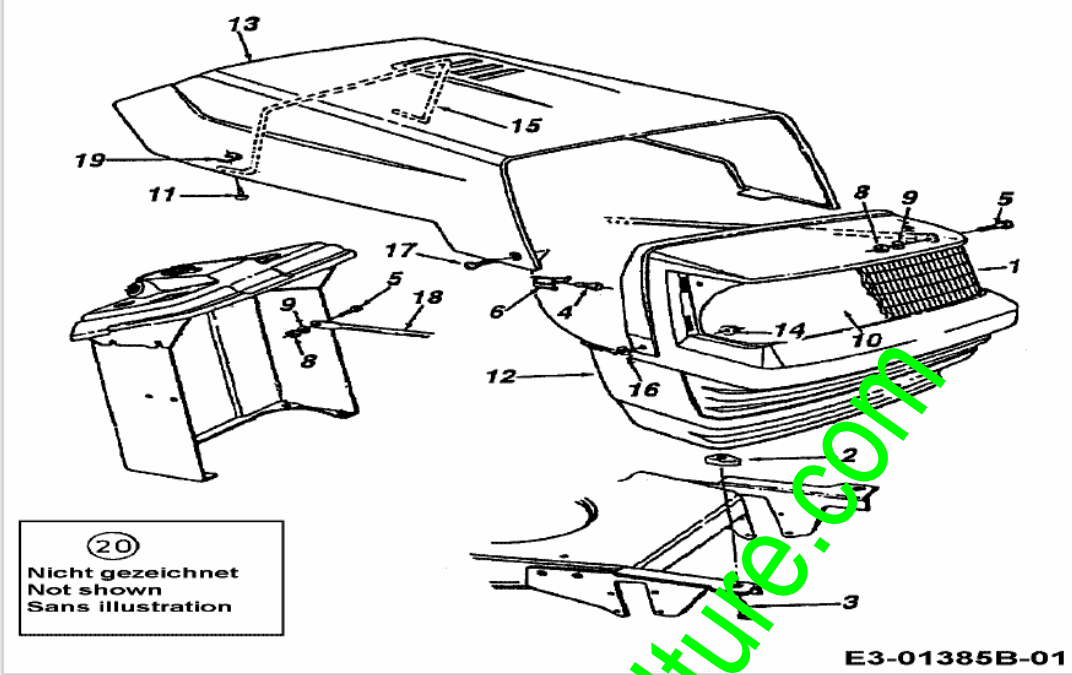

E3-01385B-01

Position	Numéro de lapièce	Appellation I	Appellation II	Remarque
1	731-1099A	OPTIQUE DE PHARE	w/o ICON	
2	712-0211	SKT-MUTTER	712-0211	
3	710-0118	VIS	FINISH:PHOS & OIL	
4	725-0963	AMPOULE ELECTRIQUE	FINISH:	
5	710-0258	VIS	710-0258	
6	725-1649	DOUILLE DE LAMPE: 1/4 ROTATION	GRAU KUNSTSTOFF	
8	712-3006	ECROU HEXAGONAL	FINISH:SPEC-100015	
9	736-0329	RONDELLE GROWER	FINISH:SPEC-100016 24.8195.16	
10	777-9206	FILM DE RÜFLECTEUR	GRILL:0/5-STYLE	
11	710-0589	VIS PARKER HEX.:#10- 16:0.750	FINISH:MTD SPEC-100016 TYPE 1	
12	731-1097D	CALANDRE		
13	783-0250	CAPOT	783-0250-0638/0674/0640/665	
14	712-3027	ECROU HEXAGONAL 1/4- 20:GRF	FINISH:MTD SPEC-100015	
15	732-0704	ETRIER: CAPOT	FINISH:PHOS & OIL	
16	736-0342	RONDELLE PLATE .283 x.75 x.030	FINISH:MTD STD 701-01000	
17	738-0952	AXE	.875 X .125: 1/4-20	
18	749-0914	VOIR 749-0914-0637	749-0914-0637 24.5" LG	
19	726-0130	ECROU 10Z TYPE U	FINISH:PHOS & OIL SIEHE ZG.	
20	629-1050	KABELBAUM VOLLST. Bus OHV	92CM TRANS	pour 13A3450E600

www.emc-motoculture.com

[www.emc-motoculture.com](http://www.emc-motoculture.com)