

REPAIR PARTS MANUAL
MODEL NO. BM115B92RB (96061010402)
LAWN TRACTOR

BESTGREEN

HOW TO USE THIS MANUAL

This manual is designed to provide the customer with a means to identify the parts on his/her tractor when ordering repair parts. The illustrations may or may not represent the actual assemblies; therefore, it is not recommended to use this manual as a guide to assemble or disassemble the tractor. Some hardware and parts are drawn larger in order to more readily identify them.

Each tractor has its own model number.

The model number for your tractor can be found on the fender under the seat.

When ordering parts, always give the following information:

- Product - "Tractor"
- Model Number - "BM155B92RB (96061010402)"
- Part Number
- Part Description

TABLE OF CONTENTS

SCHEMATIC	3
ELECTRICAL	4-5
CHASSIS	6-7
DRIVE	8-9
ENGINE	10-11
STEERING	12-13
SEAT	14
DECALS	15
MOWER DECK	16-17
MOWER LIFT	18-19
BAGGER	20

www.emc-motoculture.com

TRACTOR - MODEL NO. BM115B92RB (96061010402), PRODUCT NO. 960 61 01-04 SCHEMATIC

SCH09

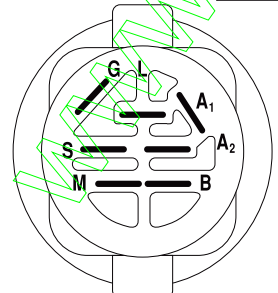
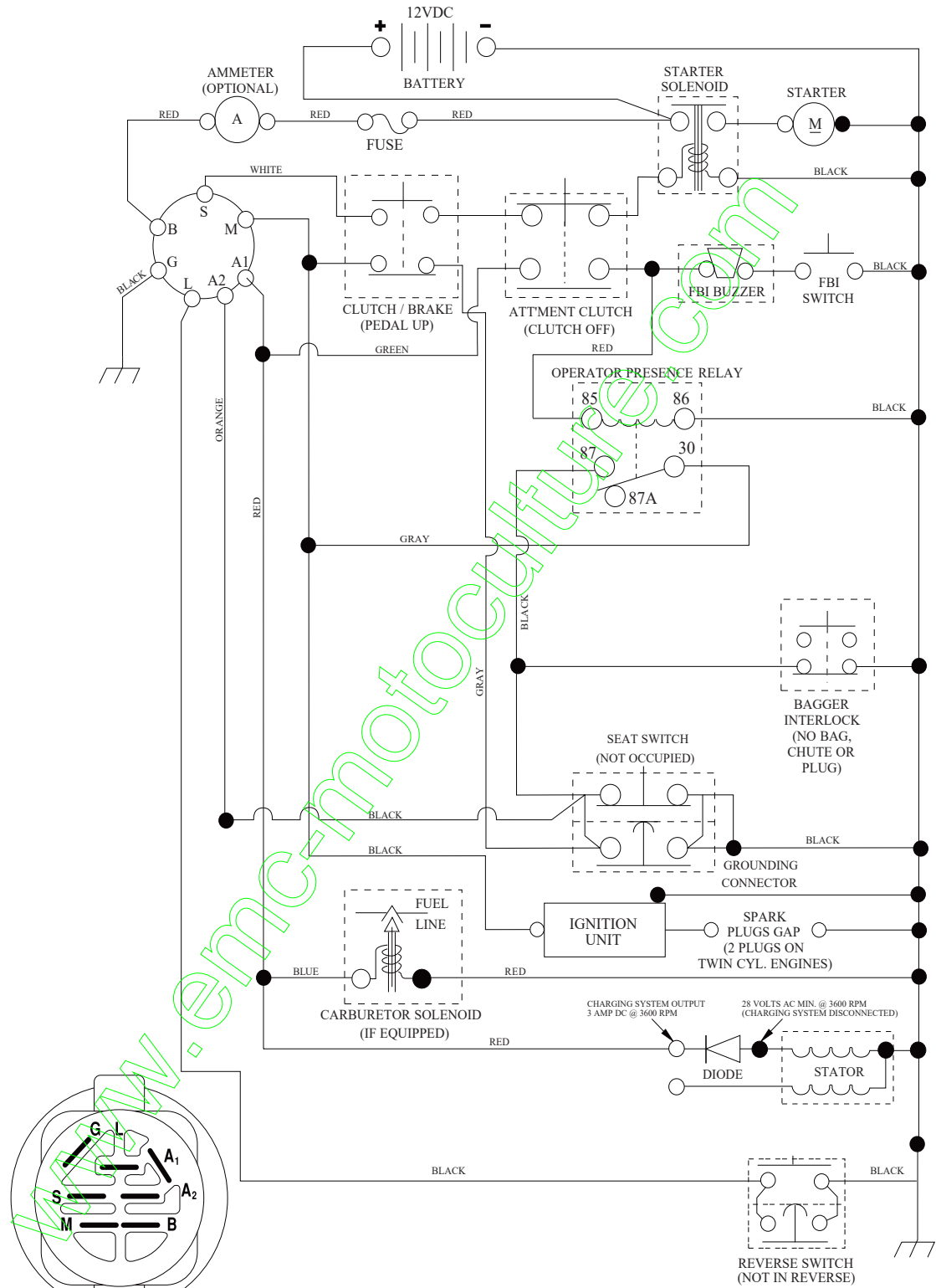

IGNITION SWITCH

POSITION	CIRCUIT "MAKE"
OFF	M+G+A1
RUN/OVERRIDE	B+A1
RUN	B+A1 L+A2
START	B + S + A1

WIRING INSULATED CLIPS
NOTE: IF WIRING INSULATED CLIPS WERE REMOVED FOR SERVICING OF UNIT, THEY SHOULD BE RE-INSTALLED TO PROPERLY SECURE YOUR WIRING.

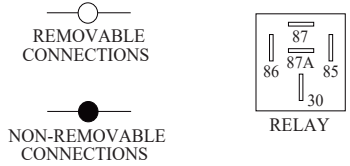

**TRACTOR - MODEL NO. BM115B92RB (96061010402), PRODUCT NO. 960 61 01-04
ELECTRICAL**

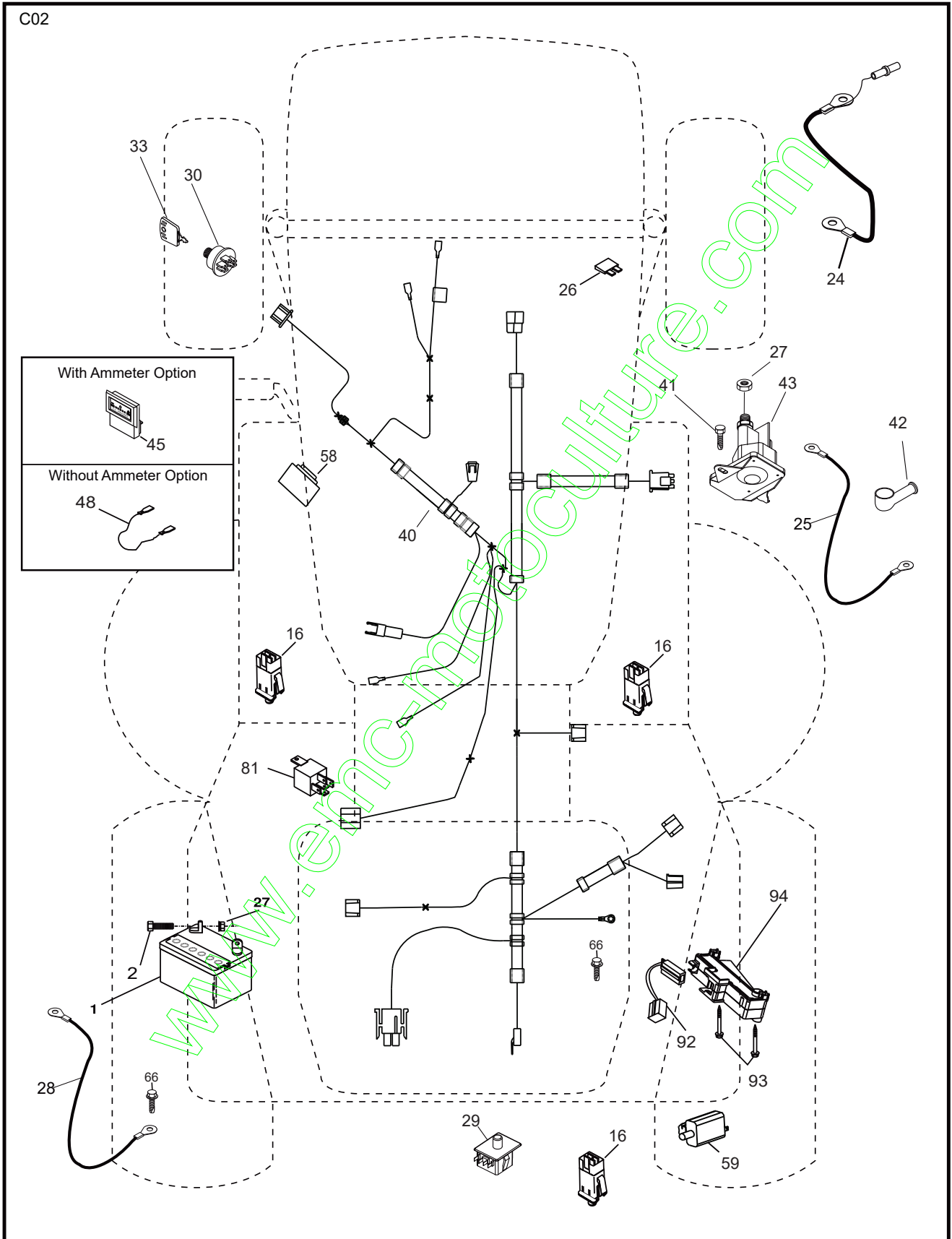

**TRACTOR - MODEL NO. BM115B92RB (96061010402), PRODUCT NO. 960 61 01-04
ELECTRICAL**

KEY NO.	PART NO.	DESCRIPTION
1	532 16 34-65	Battery
2	874 76 04-12	Bolt Hex Hd 1/4-20 unc x 3/4
16	532 17 61-38	Switch Interlock
24	532 12 47-80	Cable Starter 6 Ga. 11" Red
25	532 16 59-87	Cable Battery CRD 56" Red
26	532 17 51-58	Fuse
27	873 51 04-00	Nut Keps Hex 1/4-20 unc
28	532 12 77-25	Cable Ground 6 Ga. 18" Black
29	532 19 27-49	Switch Seat
30	532 19 33-50	Switch Ignition
33	532 41 19-35	Key/Chain
40	532 19 74-38	Harness Ign
41	871 11 04-08	Bolt Flk Fin Hex 1/4-20 unc x 1/2
42	532 13 15-63	Cover Terminal Red
43	532 19 25-07	Solenoid
48	532 14 08-44	Adapter Ammeter Rectangular
58	532 16 94-19	Buzzer CRD
59	532 18 03-79	Switch FBI CRD
66	817 49 06-08	Screw Thdrol 3/8-16 x 1/2 Ty-Tt
81	532 10 97-48	Relay Asm
92	532 19 66-15	Harness Pigtail Console ROS
93	532 19 25-40	Screw Plastite 10-14 x 2.0
94	532 19 18-34	Module Reverse

NOTE: All component dimensions given in U.S. inches.
1 inch = 25.4 mm.

**TRACTOR - MODEL NO. BM115B92RB (96061010402), PRODUCT NO. 960 61 01-04
CHASSIS AND ENCLOSURES**

KEY NO.	PART NO.	DESCRIPTION	KEY NO.	PART NO.	DESCRIPTION
1	532 17 46-20	Chassis	163	532 18 03-83	Bracket Exten Chassis RH CRD
2	532 18 03-84	Drawbar	164	532 16 56-05	Support Battery CRD
3	817 06 06-12	Screw 3/8-16 x 3/4	165	532 18 13-56	Cover Battery
5	532 15 52-72	Bumper Hood/Dash	170	532 19 94-88	Backplate Asm CRD
6	532 18 44-19	Saddle	171	872 14 06-20	Bolt Rdhd Sqnk 3/8-16 x 2-1/2 Gr. 5
8	532 12 64-71	Clip Insulator 13/32 Mtg. Hole	172	819 13 20-16	Washer 13/32 x 1-1/4 x 16 Ga.
9	532 19 46-88	Dash	173	873 51 06-00	Nut, Keps Hex 3/8-16 unc
10	872 14 06-08	Bolt, Carriage 3/8-16 x 3/4	175	532 18 82-03	Door Trap
11	532 17 49-96	Panel, Dash, LH	179	532 18 82-02	Rod Pivot FBI CRD
13	532 18 17-19	Panel, Asm. Dash RH	184	532 17 46-62	Bracket Actuator Bagger CRD
15	874 18 05-12	Screw, Machine, Truss Head 5/16-18 unc x 3/4	185	532 18 11-01	Knob Rod Brake Parking
16	873 51 05-00	Nut	186	532 16 07-93	Latch Asm Mulch/Bagger
17	532 19 47-97	Hood	187	532 00 20-29	Nut Weld
18	532 18 49-21	Bumper Hood	188	819 06 12-16	Washer #10
24	874 78 06-16	Bolt	189	810 07 10-00	Washer Lock #10
25	819 13 13-12	Washer 13/32 x 13/16 x 12 Ga.	190	871 08 10-10	Screw Pan Hd Phillip 10-24 x 5/8
26	873 80 06-00	Nut	198	532 16 89-37	Nut, Push
28	532 19 47-98	Grille	205	817 49 06-08	Screw Thdrol 3/8-16 x 1/2
30	532 19 73-44	Fender	207	817 67 05-08	Screw Thdrol 5/16-18 x 1/2
31	532 16 51-56	Bracket, Fender Support	208	817 67 06-08	Screw Thdrol 3/8-16 x 1/2
33	532 18 11-93	Footrest, LH	209	817 00 06-12	Screw Hex Wsh Thdrol 3/8-16
34	532 18 11-94	Footrest, RH	256	532 18 13-61	Cover Fender Rack CRD
35	872 11 06-06	Bolt	265	532 18 57-04	Seal RH Side Bagger
37	817 49 05-08	Screw Thdrol 5/16-18 x 1/2 TYT	266	532 18 57-03	Seal LH Side Bagger
38	532 18 17-48	Bracket Asm Pivot Mower Rear	278	532 41 63-58	Screw #10 x .750 BOS Thread
39	532 18 75-68	Bracket Pivot	307	532 42 09-19	Shield Chassis Front
69	532 14 24-32	Screw Hex Wsh	309	872 11 06-06	Bolt Rdhd Sqnk 3/8-16 x 3/4
89	532 19 73-39	Console	--	532 00 54-79	Plug
141	873 90 06-00	Nut	--	532 19 39-35	Plug Switch Light
145	532 40 91-67	Rod Pivot Hood			
162	532 18 03-82	Bracket Exten Chassis LH CRD			

NOTE: All component dimensions given in U.S. inches.
1 inch = 25.4 mm.

www.emc-motors.com

TRACTOR - MODEL NO. BM115B92RB (96061010402), PRODUCT NO. 960 61 01-04
DRIVE

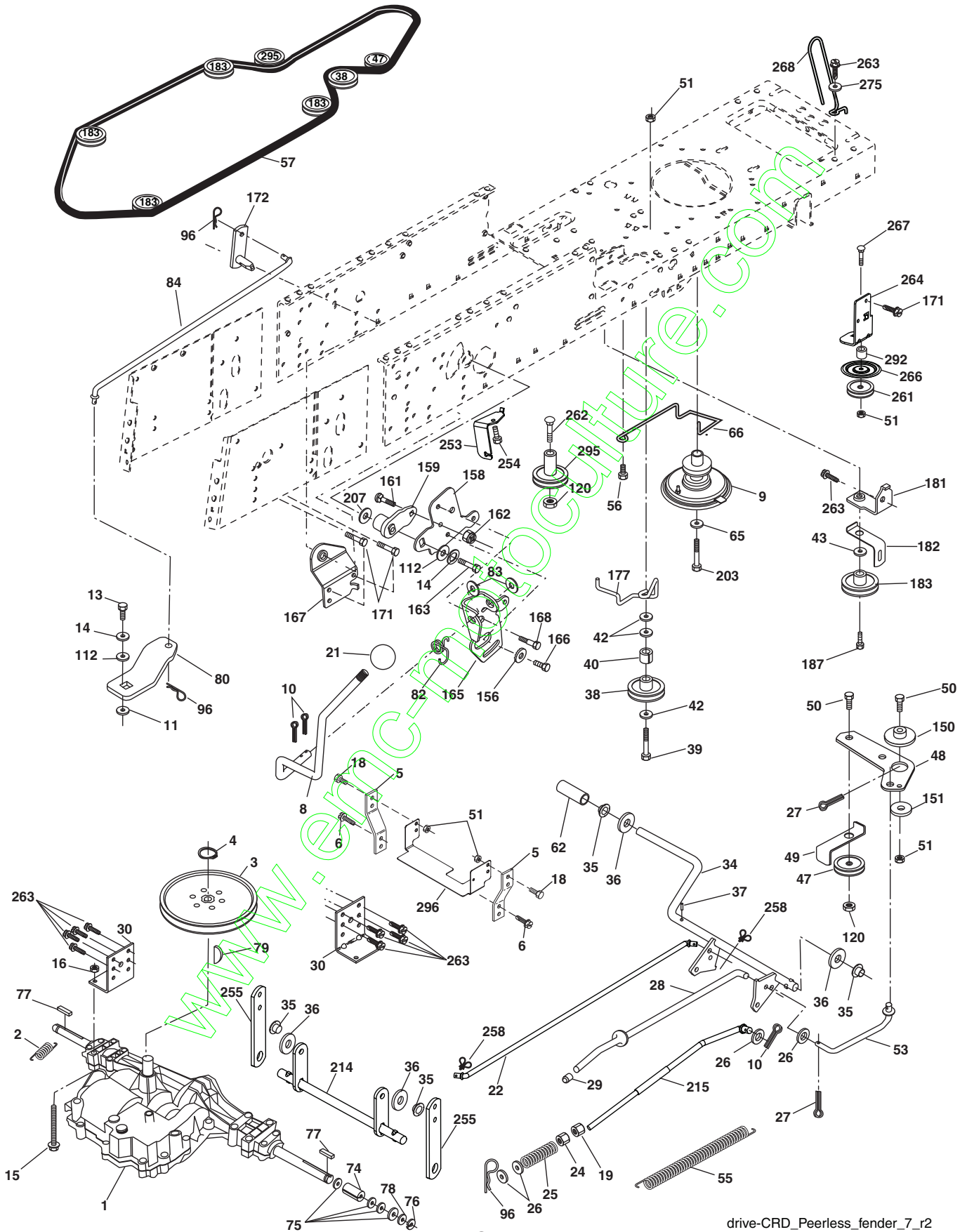

TRACTOR - MODEL NO. BM115B92RB (96061010402), PRODUCT NO. 960 61 01-04 DRIVE

KEY NO.	PART NO.	DESCRIPTION	KEY NO.	PART NO.	DESCRIPTION
1	-----	Transaxle Peerless 206-546 (Internal Parts Not Available)	79	532 12 50-96	Key Woodruff
2	532 14 66-82	Spring Brake Return	80	532 14 50-90	Arm Shift PMST 20" Tires
3	532 16 59-99	Pulley Transaxle	82	532 16 57-11	Spring, Torsion
4	812 00 00-28	Ring Retainer #5100-62	83	819 17 12-16	Washer 17/32 x 3/4 x 16 Ga.
5	532 12 15-20	Strap Torque 30 Degrees	84	532 16 56-21	Link Shift CRD Pmst 18" Tires
6	817 06 05-12	Screw 5/16-18 x 3/4	96	532 12 47-88	Spring, Retainer 1"
8	532 19 27-06	Rod Shift Fender Adjust Lt	112	819 09 12-10	Washer 9/32 x 3/4 x 10 Ga.
9	532 40 85-79	Clutch Asm Noram	120	873 90 06-00	Nut Lock 3/8-16
10	876 02 04-16	Pin, Cotter 1/8 x 1	150	532 16 58-50	Bushing, Bellcrank Grnd Dr
11	532 10 57-01	Washer Plate Shf .3888 Sq Hole	151	819 13 32-10	Washer 13/32 x 2 x 10 Ga.
13	874 55 04-12	Bolt 1/4-28 unf Gr. 8 w/Patch	156	532 16 60-02	Washer Srrd 5/16 ID x 1.125
14	810 04 04-00	Washer, Lock Hvy Helical	158	532 16 55-89	Bracket Shift Mount
15	874 49 05-44	Bolt Hex FGHD 5/16-18 x Gr. 5	159	532 18 39-00	Hub Tapered Flange Shift Lt
16	873 80 05-00	Nut, Lock Hex w/Ins 5/16-18 unc	161	872 14 04-06	Bolt Rdhd Sqnk 1/4-20 x 3/4 Gr. 5
18	874 78 06-16	Bolt Hex 3/8-16 unc x 1 Gr. 5	162	873 68 04-00	Nut Crownlock 1/4-20 unc
19	873 80 06-00	Nut, Lock Hex w/Wsh 3/8-16 unc	163	874 78 04-16	Bolt Hex Fin 1/4-20 unc x 1 Gr. 5
21	532 10 69-33	Knob Round 1/2-13 unc Blk	165	532 16 56-23	Bracket Pivot Lever
22	532 17 56-07	Rod, Brake CRD Main	166	817 49 05-10	Screw 5/16-18 x 5/8
24	873 35 06-00	Nut	167	532 16 55-88	Bracket Support Shift CRD
25	532 10 68-88	Spring, Rod, Brake	168	532 16 54-92	Bolt Shoulder 5/16-18 x .561
26	819 13 13-16	Washer 13/32 x 13/16 x 16 Ga.	171	817 49 06-08	Screw Thdrol 3/8-16 x 1/2 Ty-Tt
27	876 02 04-12	Pin, Cotter 1/8 x 3/4	172	532 16 56-35	Shaft Asm Shift Front CRD PMST
28	532 17 57-65	Rod, Parking Brake	177	532 16 59-32	Keeper Flat Idler 3.06" CRD
29	532 07 16-73	Cap, Parking Brake	181	532 18 02-11	Bracket Idler Ground Drive CRD
30	532 17 49-73	Bracket, Mfg. Transaxle	182	532 18 26-82	Keeper Belt 2.5" Od V-Idler CRD
34	532 17 55-78	Shaft, Asm Pedal Foot CRD	183	532 19 95-32	Pulley V-Idler 2.50" Od CRD
35	532 12 01-83	Bearing, Nylon	187	817 58 05-20	Screw 5/16-18 x 1.25
36	819 21 16-16	Washer 21/32 x 1 x 16 Ga.	203	871 17 07-80	Bolt Hex 7/16-20 x 5
37	532 12 49-63	Pin, Roll 3/16 x 1"	207	532 16 98-45	Washer Nylon
38	532 16 59-36	Pulley, Flat	214	532 17 56-09	Shaft Asm. Brake
39	874 76 06-44	Bolt Fin Hex 3/8-16 unc x 2-3/4	215	532 41 01-42	Rod Brake Secondary
40	532 12 49-65	Spacer, Split 395 x 59 Bzp	253	532 17 50-28	Bracket Cable Chassis
42	819 13 13-12	Washer 13/32 x 13/16 x 12 Ga.	254	817 00 06-16	Screw 3/8-16 x 1
43	819 11 10-12	Washer 11/32 x 5/8 x 12 Ga.	255	532 17 56-08	Brace Shaft Brake
47	532 12 77-83	Pulley, Idler, V Groove Plastic	258	532 17 80-62	Clip Retainer
48	532 15 44-07	Bellcrank Clutch Grnd Dry	261	532 13 14-94	Pulley Idler Flat Plated
49	532 12 32-05	Retainer, Belt Style Spring	262	872 11 06-22	Bolt 3/8-16 unc x 2-3/4 Gr.5
50	872 11 06-12	Bolt Carr Sh 3/8-16 x 1-1/2 Gr. 5	263	817 00 06-12	Screw Hex Wsh THDR 3/8-16 x 3/4
51	873 68 06-00	Nut, Crownlock 3/8-16 unc	264	532 19 76-08	Bracket Clutch
53	532 19 96-52	Link, Clutch 7.66	266	532 18 20-61	Shield Idler
55	532 10 57-09	Spring, Return, Clutch	267	872 14 06-26	Bolt Rd Hd SQNK 3/8-16 x 3-1
56	817 06 06-20	Screw 3/8-16 x 1-1/4	268	532 18 24-02	Guard Muffler OHV B&S RH
57	532 16 56-31	V-Belt Key PMST CRD	275	819 13 16-14	Washer 13/32 x 1 x 1/4 Ga.
62	532 12 48-72	Cover, Pedal	292	532 40 46-07	Spacer Noram
65	810 04 07-00	Washer	295	532 17 91-14	Pulley Idler Composite
66	532 15 47-78	Keeper, Belt Engine F-Proof	296	532 42 09-20	Shield Chassis Rear
74	532 13 70-57	Spacer Axle			
75	532 12 17-49	Washer 25/32 x 1-1/4 x 16 Ga.			
76	812 00 00-01	Ring, E			
77	532 12 35-83	Key, Square			
78	532 12 17-48	Washer 25/32 x 1-5/8 x 16 Ga.			

NOTE: All component dimensions given in U.S. inches
1 inch = 25.4 mm

**TRACTOR - MODEL NO. BM115B92RB (96061010402), PRODUCT NO. 960 61 01-04
ENGINE**

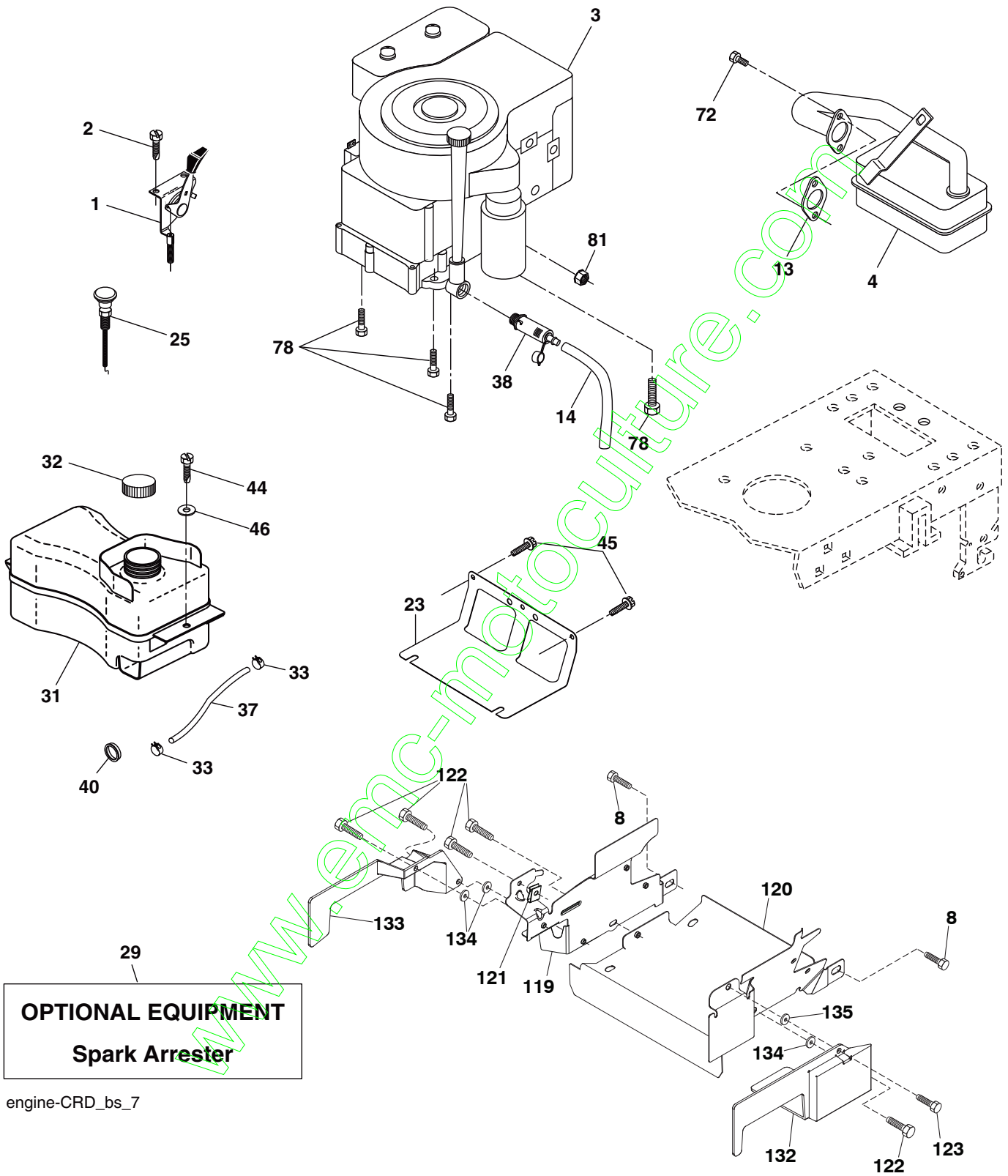

**TRACTOR - MODEL NO. BM115B92RB (96061010402), PRODUCT NO. 960 61 01-04
ENGINE**

KEY NO.	PART NO.	DESCRIPTION
1	532 17 05-51	Control Throttle
2	817 72 04-08	Screw Hex Thd Cut 1/4-20 x 1/2
3	-----	Engine B&S Model 217807
4	532 17 97-58	Muffler Exhaust B&S Lt
8	532 17 18-77	Bolt 5/16-18 unc x 3/4 w/Sems
13	532 16 52-91	Gasket 1 313 Id Tin Plated
14	532 14 84-56	Tube Drain Oil Easy
23	532 16 98-37	Shield Browning/Debris Guard
25	532 19 06-95	Control Choke
29	532 13 71-80	Arrestor Spark
31	532 40 75-16	Tank Fuel
32	532 19 77-25	Cap Asm Fuel Top Vent
33	532 12 34-87	Clamp Hose Blk
37	532 13 70-40	Line Fuel 20"
38	532 18 16-54	Plug Drain Oil Easy
40	532 12 40-28	Bushing Snap
44	817 67 04-12	Screw Hexwsh Thdrol 3/8-16 x 3/4
45	817 00 06-12	Screw 3/8-16 x 3/4
46	819 09 14-16	Washer 9/32 x 7/8 x 16-Ga.
72	532 19 23-34	Screw Socket HD 5/16-18 x .75
78	817 06 06-20	Screw 3/8-16 x 1-1/4
81	873 51 04-00	Nut Keps Hex 1/4-20 unc
119	532 19 97-68	Guard Asm Engine LH
120	532 19 97-67	Guard Asm Engine RH
121	532 19 66-88	Clips Threaded
122	532 13 77-29	Screw THD ROLL 1/4-20 x 5/8
123	817 67 05-08	Screw THDROL 5/16-18 x 1/2
132	532 42 07-57	Shield Side RH
133	532 42 07-56	Shield Side LH
134	532 42 30-62	1/4 PAL Nut
135	532 42 30-63	5/16 PAL Nut

NOTE: All component dimensions given in U.S. inches
1 inch = 25.4 mm

Engine Power Rating Information

The gross power rating for individual gas engine models is labeled in accordance with SAE (Society of Automotive Engineers) code J11940 (Small Engine Power & Torque Rating Procedure), and rating performance has been obtained and corrected in accordance with SAE J1995 (Revision 2002-5). Actual gross engine power will be lower and is affected by, among other things, ambient operating conditions and engine-to-engine variability. Given both the wide array of products on which engines are placed and the variety of environmental issues applicable to operating the equipment, the gas engine will not develop the rated gross power when used in a given piece of power equipment (actual "on-site" or net horsepower). This difference is due to a variety of factors including, but not limited to, accessories (air cleaner, exhaust, charging, cooling, carburetor, fuel pump, etc.), application limitations, ambient operating conditions (temperature, humidity, altitude), and engine-to-engine variability. Due to manufacturing and capacity limitations, Briggs & Stratton may substitute an engine of higher rated power for this Series engine.

TRACTOR - MODEL NO. BM115B92RB (96061010402), PRODUCT NO. 960 61 01-04
STEERING ASSEMBLY

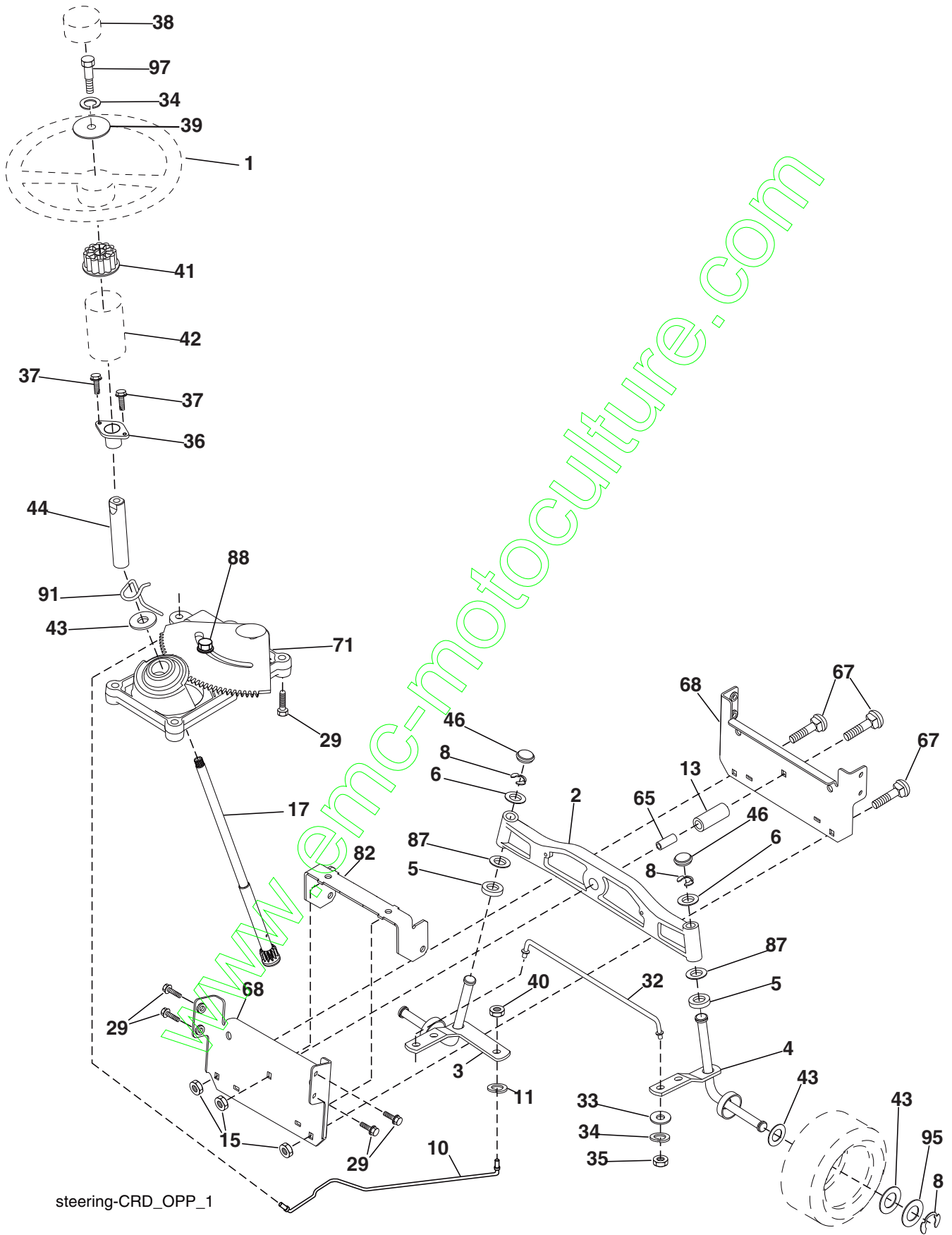

**TRACTOR - MODEL NO. BM115B92RB (96061010402), PRODUCT NO. 960 61 01-04
STEERING ASSEMBLY**

KEY NO.	PART NO.	DESCRIPTION
1	532 18 67-80	Steering Wheel
2	532 18 47-06	Front Axle Assembly
3	532 16 98-40	Spindle Assembly, LH
4	532 16 98-39	Spindle Assembly, RH
5	532 12 49-31	Washer, Thrust, Hardened
6	532 12 17-48	Washer 25/32 x 1-5/8 x 16 Ga.
8	812 00 00-29	Ring, Klip
10	532 17 51-21	Link, Drag
11	810 04 06-00	Washer, Lock
13	532 13 65-18	Spacer Axle
15	532 14 52-12	Nut Hex Flange Lock
17	532 19 07-53	Shaft Assembly, Steering
29	817 00 06-12	Screw 3/8-16 x 3/4
32	532 17 01-62	Rod, Tie
33	819 11 12-16	Washer 11/32 x 3/4 x 16 Ga.
34	810 04 05-00	Washer Lock Hvy Hlcl Spr 5/16
35	873 54 05-00	Crownlock Nut 5/16-24 unf
36	532 15 50-99	Bushing, Steering
37	532 15 29-27	Screw TT #10-32 x 5 x 3/8 Flange
38	532 19 29-16	Cap Wheel Steering
39	819 11 38-12	Washer 11/32 ID x 2-3/8 OD 12 Ga.
40	873 54 06-00	Nut Crownlock 3/8-24
41	532 18 67-37	Adaptor, Steering Wheel
42	532 16 96-33	Boot, Steering Dash P/L Mtl
43	532 12 17-49	Washer 25/32 x 1-1/4 x 16 Ga.
44	532 19 07-52	Extension Steering
46	532 12 12-32	Cap, Spindle
65	532 41 47-36	Spacer Axle
67	872 11 06-18	Bolt Rdhd Sq 3/8-16 x 2-1/4
68	532 16 98-27	Brace Axle
71	532 17 51-46	Steering Asm.
82	532 19 99-78	Bracket Susp. Chassis Front
87	532 17 39-66	Washer Flat .781 x 1-1/2 x .14
88	532 17 51-18	Bolt Shoulder 7/16-20 unc
91	532 17 55-53	Clip Steering
95	532 18 89-67	Washer
97	874 78 05-64	Bolt 5/16-18 unc x 4" L Gr. 5

NOTE: All component dimensions given in U.S. inches.
1 inch = 25.4 mm.

**TRACTOR - MODEL NO. BM115B92RB (96061010402), PRODUCT NO. 960 61 01-04
SEAT ASSEMBLY**

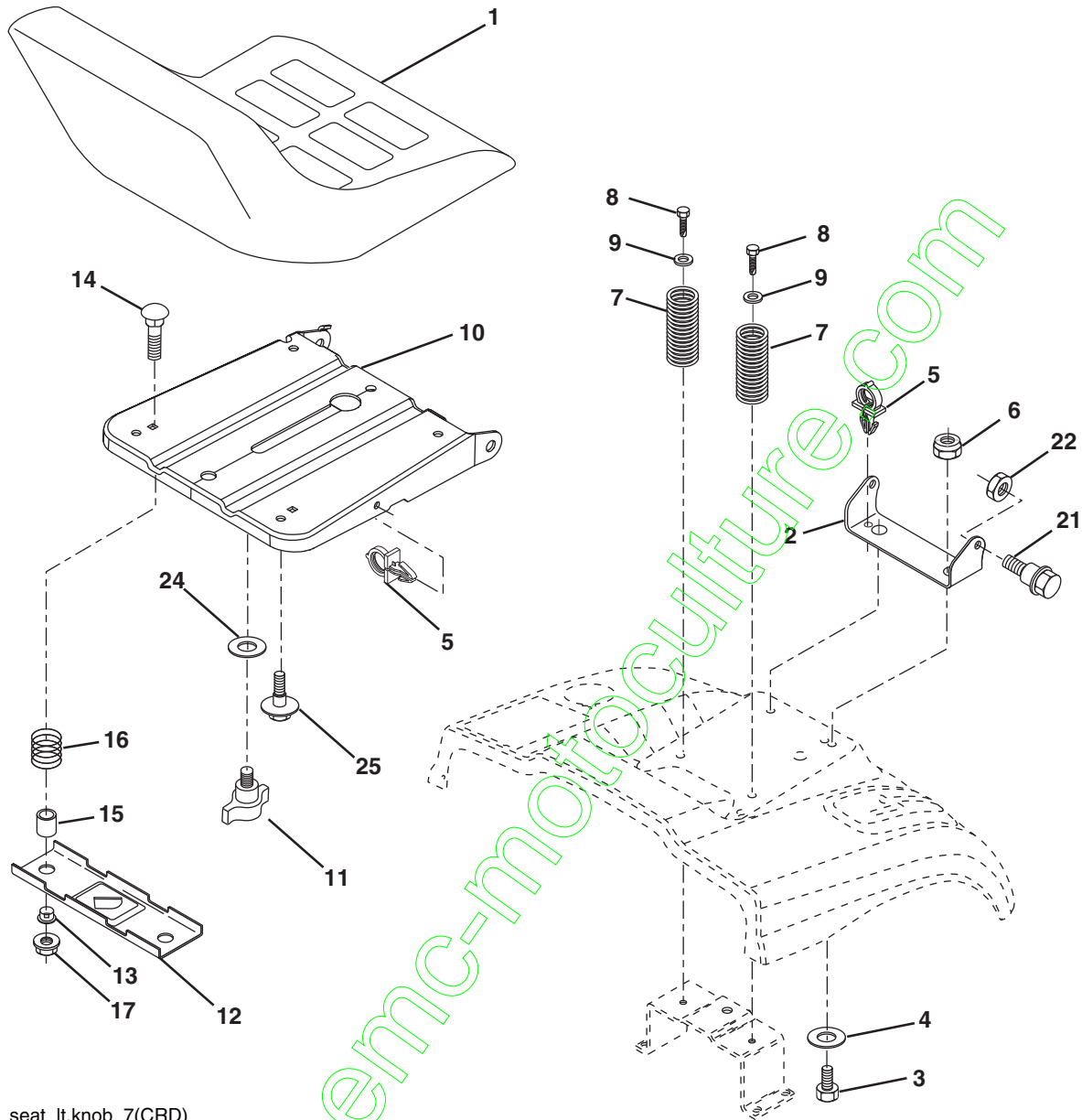

seat_lt.knob_7(CRD)

KEY NO.	PART NO.	DESCRIPTION
1	532 40 10-42	Seat
2	532 14 05-51	Bracket Piyot Seat
3	871 11 06-16	Bolt Fin Hex 3/8-16 x 1 Blk
4	819 13 16-10	Washer Flat 13/32 x 1 x 10 Ga.
5	532 14 50-06	Clip Push In Hinged
6	873 80 06-00	Nut Lock Hex w/Insert 3/8-16
7	532 12 41-81	Spring Seat Cprsn 2 250 Blk Zi
8	817 00 06-16	Screw 3/8-16 x 1.5
9	819 13 16-14	Washer 13/32 x 1 x 14 Ga.
10	532 19 55-30	Pan Seat
11	532 16 63-69	Knob Seat Adj. Wingnut
12	532 17 46-48	Bracket Pnt Mounting Switch

KEY NO.	PART NO.	DESCRIPTION
13	532 12 12-48	Bushing Snap Blk Nyl 50 Id
14	872 05 04-12	Bolt Rdhd Sht Nk 1/4-20 x 1-1/2
15	532 13 43-00	Spacer Split
16	532 12 12-50	Spring Cprsn
17	532 12 39-76	Nut Lock 1/4 Lge Flg Gr. 5 Zinc
21	532 17 18-52	Bolt Shoulder 5/16-18 unc-2A
22	873 80 05-00	Nut Hex Lock w/Ins 5/16-18
24	819 17 19-12	Washer 17/32 x 1-3/16 x 12 Ga.
25	532 12 70-18	Bolt Shoulder 5/16-18 x .62

NOTE: All component dimensions given in U.S. inches.
1 inch = 25.4 mm

**TRACTOR - MODEL NO. BM115B92RB (96061010402), PRODUCT NO. 960 61 01-04
DECALS**

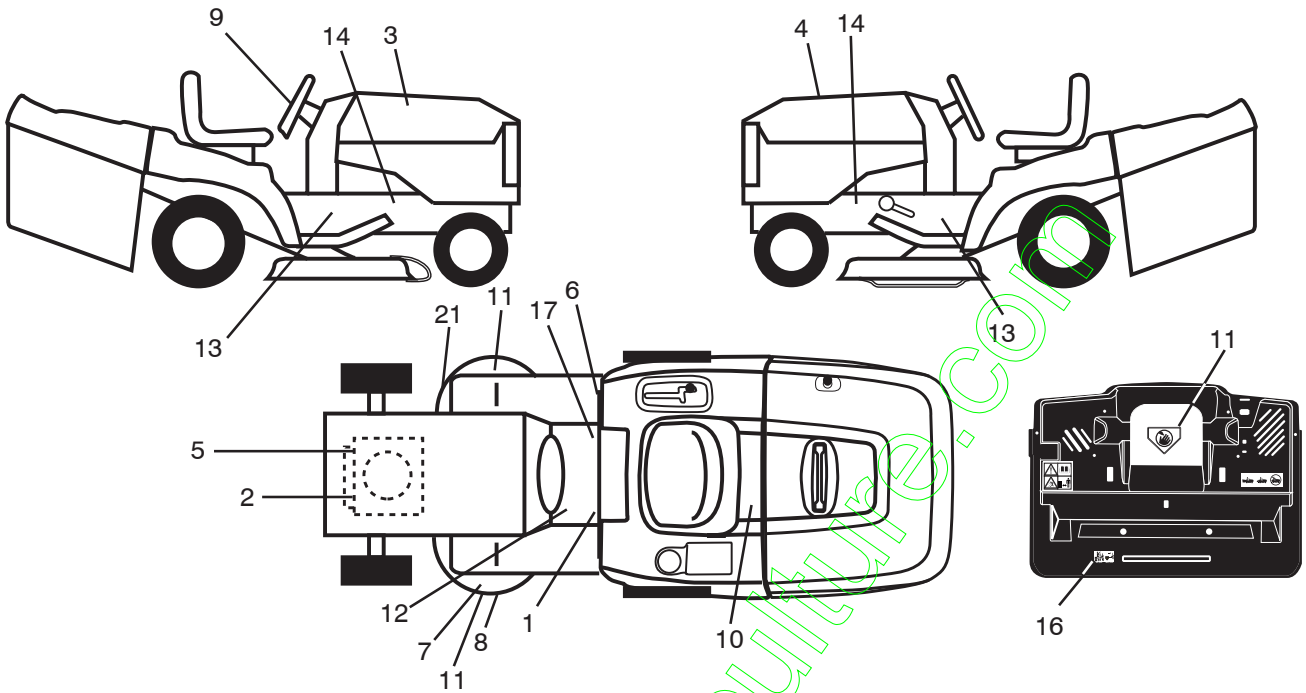

KEY NO.	PART NO.	DESCRIPTION	KEY NO.	PART NO.	DESCRIPTION
1	532 40 03-89	Decal Warning Symbols CE	12	532 15 97-37	Decal Brake/Clutch Symbol Lt
2	532 40 88-12	Decal 11.5 HP	13	532 40 11-46	Decal Warning Service/Fire
5	532 19 68-41	Decal Warning Eng. Syms	14	532 15 97-36	Decal Chassis Hot Muffler
6	532 18 04-32	Decal 100 DBA/CE	16	532 18 04-35	Decal Backplate
7	532 19 68-42	Decal SOL SHF/CRD Sym Cutfinger	17	532 14 08-37	Decal Saddle Brake Parking
8	532 18 78-11	Decal Deck Enviro	21	532 16 62-86	Decal Hex Belt Sch 92 CRD
9	532 40 23-03	Decal Steering Wheel	--	532 13 83-11	Decal Lift Handle
10	532 14 50-05	Decal Bat Dan/Poi P/L Sym Wpn	--	532 40 19-97	Manual Operator's (Euro)
11	532 18 21-66	Decal Mower Cut Finger Symbol	--	532 42 24-54	Manual Parts

WHEELS & TIRES

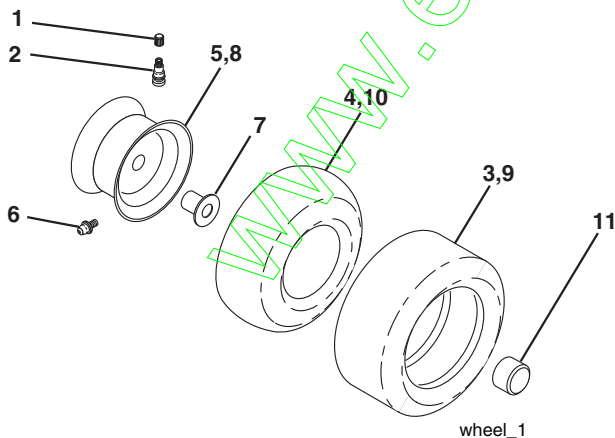

KEY NO.	PART NO.	DESCRIPTION
1	532 05 91-92	Cap Valve Tire
2	532 06 51-39	Stem Valve
3	532 10 62-22	Tire F Ts 15 x 6 0 - 6 Service
4	532 05 99-04	Tube Inner Front #35060
5	532 13 83-37	Rim Asm 6" Front Service
6	532 12 49-57	Fitting Grease
7	532 12 49-59	Bearing Flange
8	532 18 33-38	Rim Asm 8" Rear Service
9	532 42 05-31	Tire R Ts LT 18 x 9.5-8
10	532 12 49-26	Tube Rear 9 5 x 8 Service
11	532 17 50-39	Cap Axle Blk 1 50 x 1 00
--	532 14 43-34	Sealant, Tire (10 oz. tube)

NOTE: All component dimensions given in U.S. inches
1 inch = 25.4 mm

TRACTOR - MODEL NO. BM115B92RB (96061010402), PRODUCT NO. 960 61 01-04
MOWER

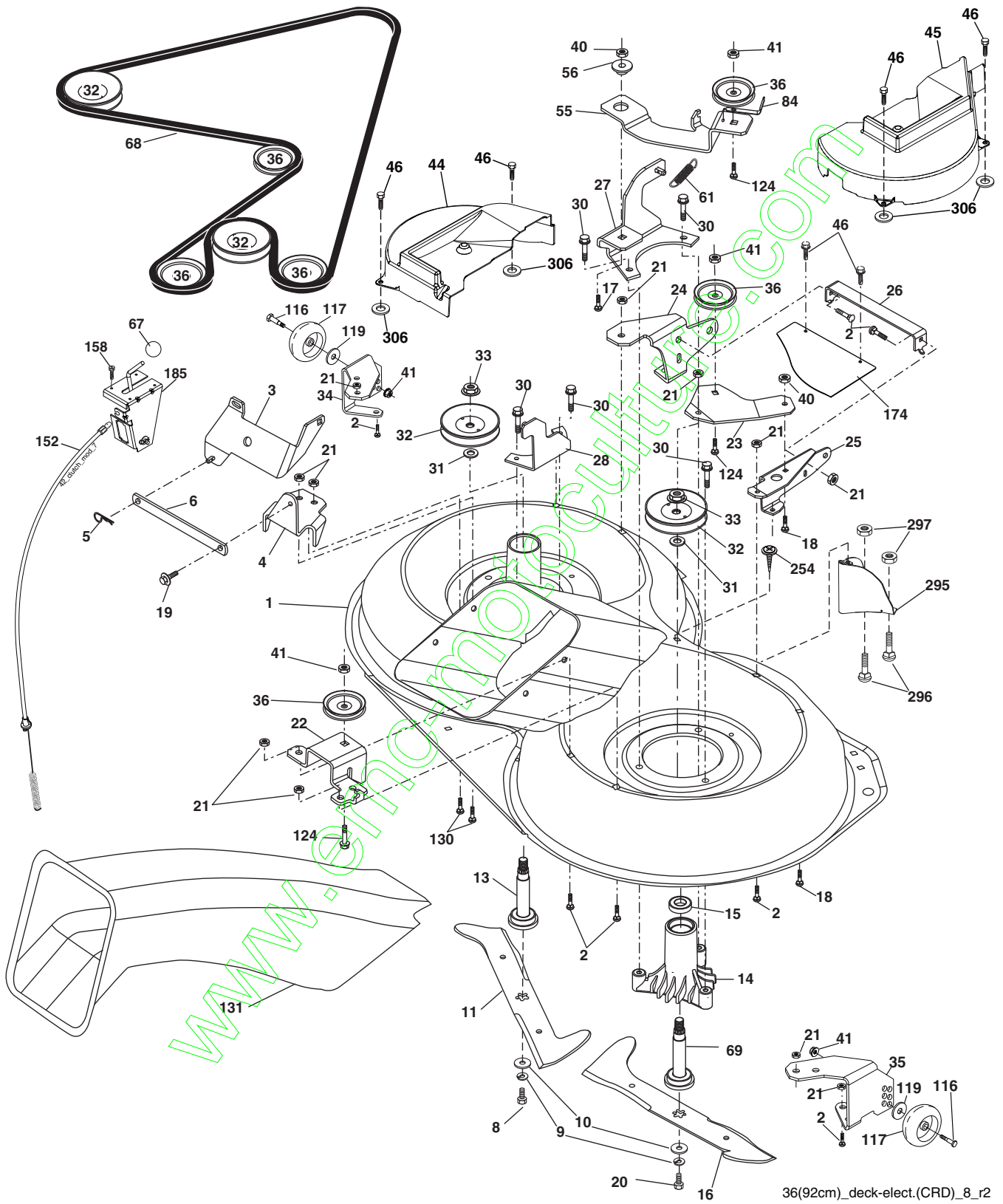

36(92cm)_deck-elect.(CRD)_8_r2

**TRACTOR - MODEL NO. BM115B92RB (96061010402), PRODUCT NO. 960 61 01-04
MOWER**

KEY NO.	PART NO.	DESCRIPTION	KEY NO.	PART NO.	DESCRIPTION
1	532 40 01-08	Housing Asm. Mower	41	873 90 06-00	Nut Lock Flg. 3/8-16 unc
2	872 14 05-06	Bolt Rdhd Sqnk 5/16-18 unc x 3/4	44	532 42 07-52	Cover Mandrel LH
3	532 16 55-69	Bracket Asm. S-Bar Chass	45	532 42 07-53	Cover Mandrel RH
4	532 16 55-58	Bracket Bar Sway Deck	46	532 13 77-29	Screw Thd Roll 1/4-20 x 5/8
5	532 12 46-70	Retainer Spring	55	532 19 94-98	Arm Idler
6	532 16 55-57	Bar Sway	56	532 16 57-23	Spacer Retainer PM Mower
8	532 18 17-12	Bolt 3/8-24 x 1.25 Gr. 8 Patched	61	532 19 94-86	Spring Tension Belt
9	810 03 06-00	Washer Lock Hvy 3/8 Unplated	67	532 10 69-32	Knob Rd 3/8-16 Plstc Thds Blk
10	532 14 02-96	Washer Hard Blade	68	532 40 20-08	Belt Drive
11	532 18 63-85	Blade 3-1 LH	69	532 16 54-82	Shaft Asm w/Lwr Brg RH Thd CRD
13	532 13 76-45	Shaft Asm. w/Lower Bearing	84	532 15 60-85	Keeper Belt Idler
14	532 12 87-74	Housing Mandrel Vented (Machd)	116	532 19 34-06	Bolt Shoulder
15	532 11 04-85	Bearing Ball Mandrel	117	532 17 48-73	Wheel Gauge
16	532 18 63-86	Blade 3-1 RH	119	819 12 14-14	Washer 3/8 x 7/8 x 14 Ga.
17	872 14 06-10	Bolt Carriage 3/8-16 x 1-1/4	124	872 11 06-12	Bolt Carr Sh 3/8-16 x 1-1/2 Gr. 5
18	872 11 06-06	Bolt Rdhd Sqnk 3/8-16 x 3/4	130	872 11 05-06	Bolt Rdhdsqnk 5/16-18 unc x 3/4
19	532 13 28-27	Bolt Shoulder 5/16-18 Thd Form	131	532 16 56-61	Chute Bagger CRD
20	532 18 17-13	Bolt 3/8-24 x 1.25 Gr. 8 Ptch Lhthd	152	532 17 60-74	Cable Clutch CRD Service
21	873 68 05-00	Nut Crown Lock 5/16-18	158	817 72 04-08	Screw Hex Thdcut 1/4-20 x 5/8
22	532 19 95-90	Bracket Idler Sprt RR	174	532 40 02-41	Guard Front Susp.
23	532 16 54-46	Bracket Idler Sprt RF	185	532 18 82-34	Head Asm. Cable Clutch
24	532 16 52-42	Bracket Suspension LF	254	817 00 06-16	Screw 3/8-16 x 1
25	532 16 52-44	Bracket Suspension RF	295	532 41 21-71	Baffle Front
26	532 40 01-10	Brace Support Susp Frt CRD	296	872 14 04-06	Bolt RDHD SQNK 1/4-20 x 3/4 Gr. 5
27	532 16 55-68	Bracket Asm. Susp RR	297	873 93 04-00	Nut Center Lock 1/4-20 unc
28	532 16 55-67	Bracket Asm. Susp LR	306	532 42 30-62	1/4" Pal Nut
30	532 17 39-84	Screw Thd Rolling Washer Head	--	532 18 18-57	Mandrel Asm Service
31	532 18 76-90	Washer Spacer	--	532 18 18-58	Mandrel Asm CRD LH Threads SVC
32	532 15 35-32	Mandrel Pulleys	--	532 42 27-85	Replacement Mower Complete (Std. Deck - Order separately gauge wheel components Key Nos. 116-119)
33	532 40 02-34	Nut Flg Top Lock			
34	532 40 01-07	Bracket Gauge Wheel LF			
35	532 40 01-06	Bracket Gauge Wheel RF			
36	532 14 67-63	Pulley Idler V-Groove Dim 4-25			
40	873 68 06-00	Nut Lock 3/8-16 unc			

NOTE: All component dimensions given in U.S. inches
1 inch = 25.4 mm

**TRACTOR - MODEL NO. BM115B92RB (96061010402), PRODUCT NO. 960 61 01-04
MOWER LIFT**

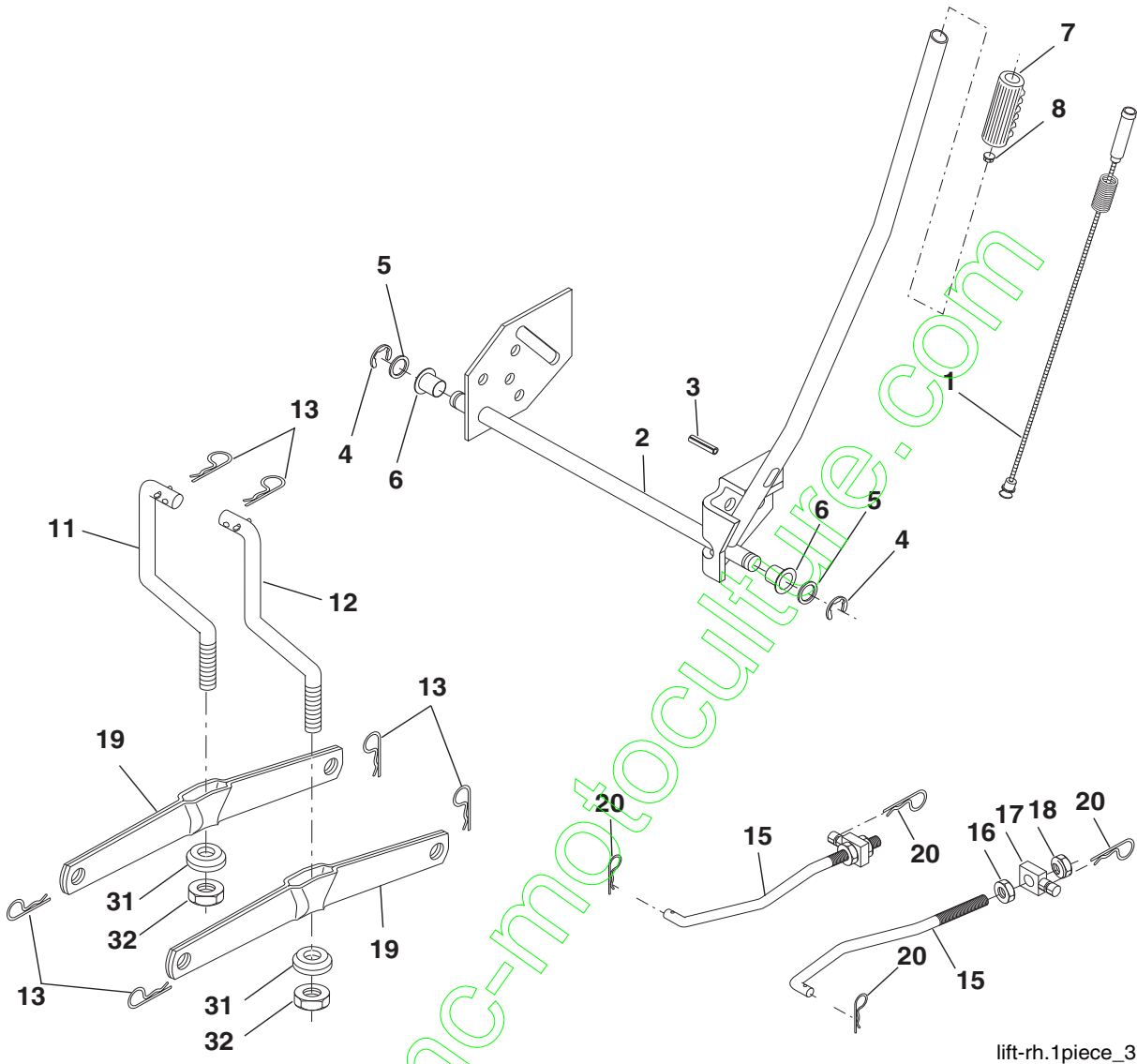

lift-rh.1piece_3

KEY NO.	PART NO.	DESCRIPTION
1	532 40 49-41	Plunger Asm. Lift Lvr.
2	532 15 94-71	Shaft Asm. Lift
3	532 10 57-67	Pin Groove
4	812 00 00-02	E Ring #5133-62
5	819 21 16-21	Washer 21/32 x 1 x 21 Ga.
6	532 12 01-83	Bearing Nylong
7	532 10 94-13	Grip Handle
8	532 12 45-26	Button Plunger Black
11	532 16 58-29	Link Asm Lift LH
12	532 16 58-31	Link Asm Lift RH
13	532 12 46-70	Retainer Spring

KEY NO.	PART NO.	DESCRIPTION
15	532 17 32-88	Link Front
16	873 35 08-00	Nut Jam Hex 1/2-13 unc
17	532 17 56-89	Trunnion Blk Zinc
18	873 80 08-00	Nut Lock w/Wsh 1/2-13 unc
19	532 13 98-68	Arm Suspension Mower
20	532 19 42-09	Retainer Spring
31	532 16 98-65	Bearing, Pvt. Lift.
32	873 54 06-00	Nut Crownlock 3/8-24

NOTE: All component dimensions given in U.S. inches
1 inch = 25.4 mm

**TRACTOR - MODEL NO. BM115B92RB (96061010402), PRODUCT NO. 960 61 01-04
BAGGER**

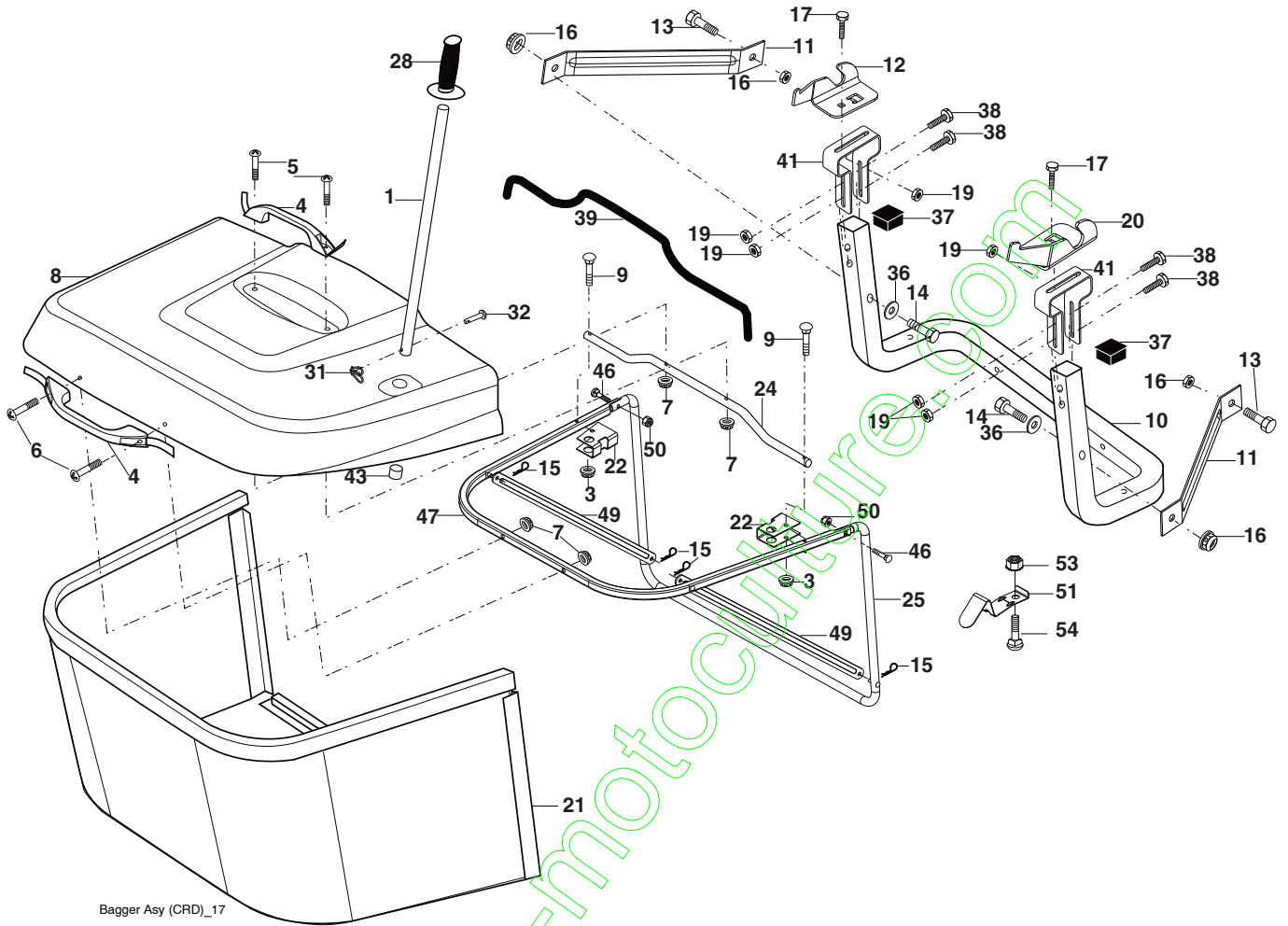

Bagger Asy (CRD)_17

KEY NO.	PART NO.	DESCRIPTION	KEY NO.	PART NO.	DESCRIPTION
1	532 16 52-49	Tube Handle Bagger CRD	25	532 19 37-05	Tube Front Bagger CRD
3	532 12 39-76	Nut Lock 1/4 Lge Flg Gr. 5 Zinc	28	532 16 57-87	Grip Handle Black
4	532 16 99-16	Handle Bagger w/Lvrs Blk CRD	31	532 16 94-84	Retainer Clip
5	874 98 10-24	Screw Pan Head #10-24 x 1.50 Blk	32	532 12 68-75	Rivet Rd Hd Drilled 3/8 Dia
6	874 98 10-32	Screw Pan Hd	36	819 13 20-12	Washer 13/32 x 1-1/4 x 12 Ga.
7	873 40 10-00	Nut Wiz Lock Hex Serr/Hd 10-24	37	532 17 54-01	Plug Support Bagger CRD
8	532 18 13-54	Cover Bagger	38	872 01 05-20	Bolt 5/16-18 x 2-1/2
9	872 14 04-18	Bolt Carriage 1/4-20 x 2.25 d x Gr. 5	39	532 41 62-57	Seal Bagger
10	532 18 12-82	Tube Support Bagger CRD	41	532 16 96-83	Bracket Pnt Adj Pvt Bagger CRD
11	532 16 57-19	Bracket Support Upper Bag CRD	43	532 17 40-83	Plug Tubing End
12	532 18 88-48	Bracket Pivot LH	46	872 11 05-10	Bolt Carr. 5/16-18 x 1-1/4 Gr. 5
13	874 76 06-12	Bolt Fin Hex 3/8-16 unc x 2	47	532 19 37-04	Tube Upper Bagger
14	874 52 06-36	Bolt Fin Hex 3/8-16 x 2-1/4 Gr. 5	49	532 19 33-05	Bar Spreader Bagger
15	532 12 46-70	Retainer Spring	50	873 80 05-00	Nut Lock Hex w/INS 5/16-18 unc
16	873 90 06-00	Nut Lock Flg 3/8-16 unc	51	532 19 99-03	Latch Spring Bagger
17	872 14 05-06	Bolt Rdhd Sht Sqnk 5/16-18 uncx 3/4	53	873 51 04-00	Nut Keps Hex 1/4-20 unc
19	873 90 05-00	Nut Lock Hex Flange 5/16-18	54	872 14 04-06	Bolt RDHD SQNK 1/4-20 x 3/4 Gr. 5
20	532 18 88-47	Bracket Pivot RH			
21	532 40 61-80	Bag Asm CRD			
22	532 16 57-81	Bracket Side Bagger CRD			
24	532 16 57-83	Tube Pivot Bagger CRD			

NOTE: All component dimensions given in U.S. inches
1 inch = 25.4 mm

www.emc-motoculture.com