

REPAIR PARTS MANUAL
MODEL NO. BM11M91 (BM11M92A)
Lawn Tractor

HOW TO USE THIS MANUAL

This manual is designed to provide the customer with a means to identify the parts on his/her tractor when ordering repair parts. The illustrations may or may not represent the actual assemblies; therefore, it is not recommended to use this manual as a guide to assemble or disassemble the tractor. Some hardware and parts are drawn larger in order to more readily identify them.

Each tractor has its own model number.

The model number for your tractor can be found on the fender under the seat.

When ordering parts, always give the following information:

- Product - "Lawn Tractor"
- Model Number - BM11M91 (BM11M92A)
- Part Number
- Part Description

TABLE OF CONTENTS

SCHEMATIC	3
ELECTRICAL.....	4-5
CHASSIS AND ENCLOSURES.....	6-7
DRIVE.....	8-9
SEAT	10
DECALS.....	11
STEERING WHEEL	12-13
ENGINE.....	14-15
MOWER DECK	16-17
MOWER LIFT	18
WARRANTY	20

TRACTOR - - MODEL NO. BM11M91 (BM11M92A), PRODUCT NO. 964 79 45-00 SCHEMATIC

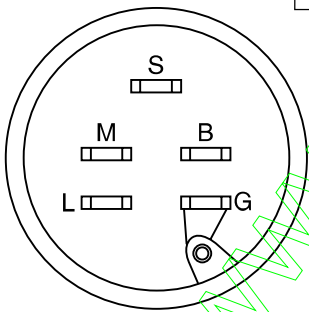
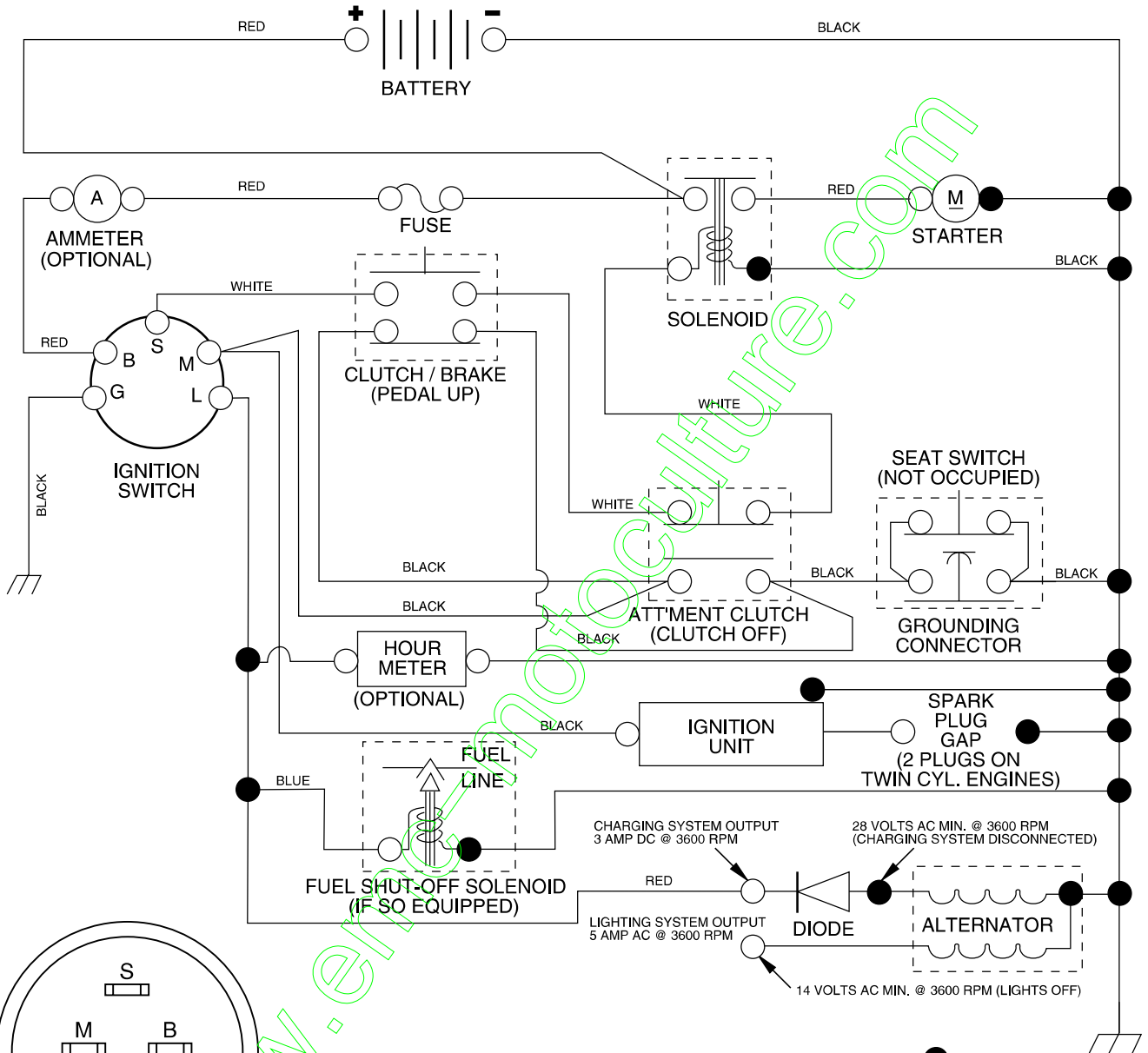

IGNITION SWITCH

POSITION	CIRCUIT
OFF	M + G
ON	B + L
START	B + S + L

WIRING INSULATED CLIPS
NOTE: IF WIRING INSULATED CLIPS WERE REMOVED FOR SERVICING OF UNIT, THEY SHOULD BE REPLACED TO PROPERLY SECURE YOUR WIRING.

● ——— ●
NON-REMOVABLE CONNECTIONS

○ ——— ○
REMOVABLE CONNECTIONS

REPAIR PARTS

TRACTOR -- MODEL NO. BM11M91 (BM11M92A), PRODUCT NO. 964 79 45-00
ELECTRICAL

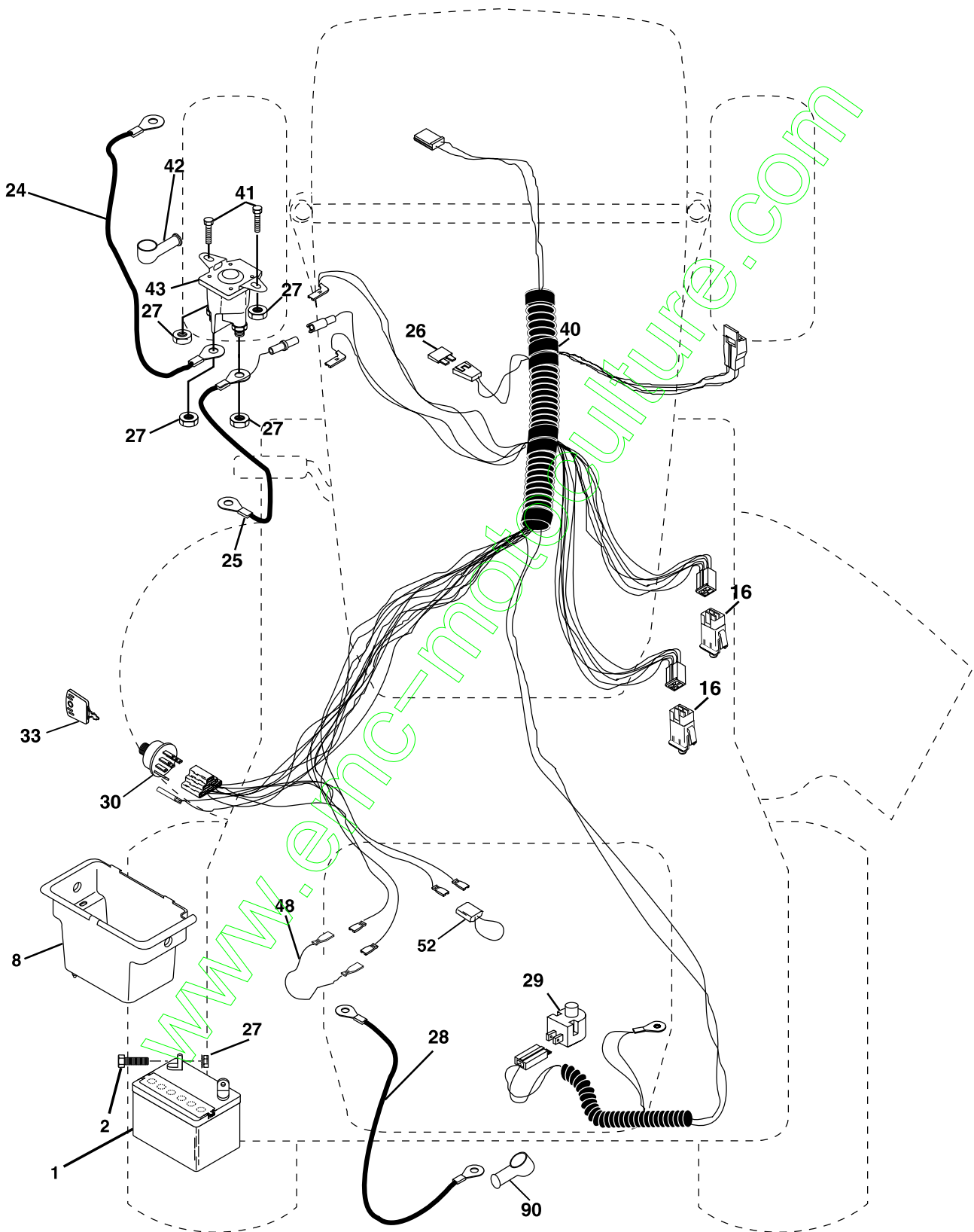

REPAIR PARTS

TRACTOR - - MODEL NO. BM11M91 (BM11M92A), PRODUCT NO. 964 79 45-00
ELECTRICAL

KEY NO.	PART NO.	DESCRIPTION
1	532 16 34-65	Battery 12 Volt 25 AMP
2	874 76 04-12	Bolt Hex Hd 1/4-20unc X 3/4
8	532 17 66-89	Box Battery
16	532 17 61-38	Switch Interlock Push-In
24	532 00 47-99	Cable Battery
25	532 14 61-47	Cable Battery 6 Ga 44" red
26	532 17 51-58	Fuse 20 AMP
27	873 51 04-00	Nut Keps Hex 1/4-20 Unc
28	532 00 42-07	Cable Ground 6 Ga 12" black
29	532 12 13-05	Switch Plunger Nc Gray
30	532 17 55-67	Switch Ign
33	532 14 04-01	Key Ign
40	532 17 97-30	Harness Ignition
41	871 11 04-08	Bolt Blk Fin Hex 1/4 - 20 x 1/2
42	532 13 15-63	Cover Terminal Red
43	532 17 88-61	Solenoid
48	532 14 08-44	Adapter Ammeter
52	532 14 19-40	Protection Wire Loop
90	532 18 04-49	Cover Terminal

NOTE: All component dimensions give in U.S. inches
1 inch = 25.4 mm.

REPAIR PARTS

TRACTOR -- MODEL NO. BM11M91 (BM11M92A), PRODUCT NO. 964 79 45-00
CHASSIS AND ENCLOSURES

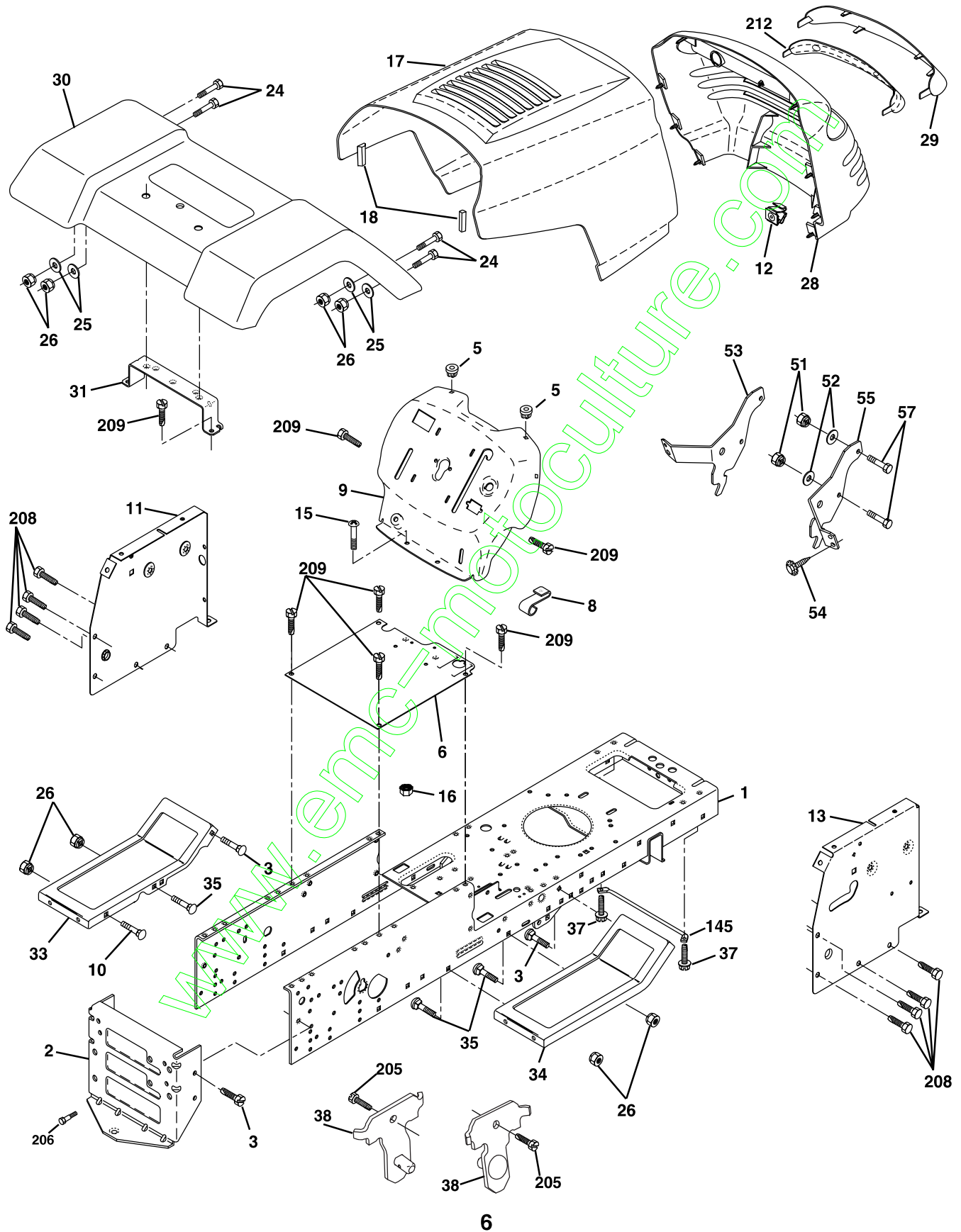

REPAIR PARTS

TRACTOR - - MODEL NO. BM11M91 (BM11M92A), PRODUCT NO. 964 79 45-00
CHASSIS AND ENCLOSURES

KEY NO.	PART NO.	DESCRIPTION
1	532 17 46-20	Chassis
2	532 17 65-54	Drawbar
3	817 06 06-12	Screw, 3/8-16 x 3/4 SMGML Tap/R
5	532 15 52-72	Bumper Hood/Dash
6	532 18 12-71	Saddle Flat
8	532 15 51-38	Clip Retainer Slide-On
9	532 18 54-80	Dash P/L
10	872 14 06-08	Bolt, Rdhd Sqnk 3/8-16 x 1
11	532 17 49-96	Panel Asm.Dash LH
12	532 14 56-60	Clip Tinnerman Grille P/L
13	532 18 17-19	Dash, Panel RH
15	874 18 05-12	Screw Mach.Trhd 5/16-18 UNC x 3/4
16	873 51 05-00	Nut Keps 5/16-18 UNC
17	532 16 35-57	Hood Pnt Sil PL
18	532 18 49-21	Bumper Hood
24	874 78 06-16	Bolt, Hex, Fin, 3/8-16UNC x 1 Gr. 5
25	819 13 13-12	Washer 13/32 x 13/16 x12 Gauge
26	873 80 06-00	Nut Lock Hex w/Ins. 3/8-16 Unc
28	532 17 97-80	Grille
29	532 18 25-36	Lens Grille
30	532 18 25-35	Fender Pnt
31	532 13 66-19	Bracket Fender
33	532 18 11-93	Footrest Pnt., LH
34	532 18 11-94	Footrest Pnt., RH
35	872 11 06-06	Bolt Rdhd Sht. Sqnk 3/8-16 X 3/4
37	817 49 05-08	Screw Thdrol 5/16-18 x 1/2 Tyt
38	532 17 57-10	Bracket Asm Pivot Mower Rear
51	873 80 04-00	Nut Lock Hex W/Ins 1/4-20
52	819 09 14-16	Washer 9/32 x 7/8 x 16 Ga.
53	532 14 46-97	Bracket, Grille LH
54	532 16 14-64	Screw Hex WSHD 8-18 x 7/8
55	532 14 46-96	Bracket Grille RH
57	874 78 04-12	Bolt Fin Hex 1/4-20 x 3/4
145	532 15 65-24	Rod Pivot Chassis/Hood
205	817 49 06-08	Screw Thdrol 3/8-16 x 1/2
206	532 17 01-65	Bolt Shoulder 5/16-18
208	817 67 06-08	Screw Thdrol 3/8-16 x 1/2
209	817 00 06-12	Screw Hex Wsh Thdrol 3/8-16 x 3/4
212	532 15 64-94	Insert Lens Reflect Quarda
--	532 00 54-79	Plug Btn Blk .359 Dia Ch/Inf

NOTE: All component dimensions given in U.S. inches
1 inch = 25.4 mm

REPAIR PARTS

TRACTOR -- MODEL NO. BM11M91 (BM11M92A), PRODUCT NO. 964 79 45-00
DRIVE

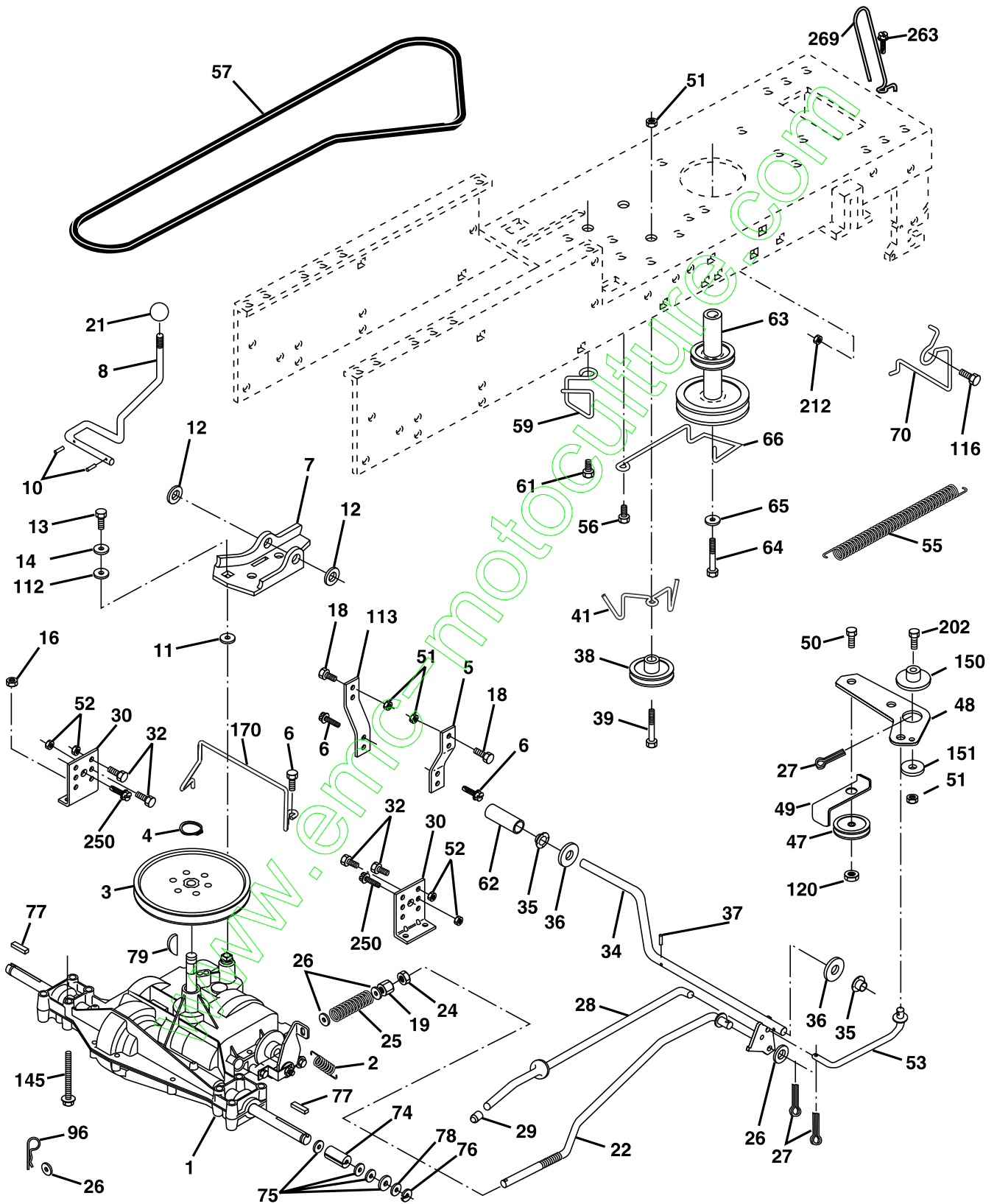

REPAIR PARTS

TRACTOR - - MODEL NO. BM11M91 (BM11M92A), PRODUCT NO. 964 79 45-00
DRIVE

KEY NO.	PART NO.	DESCRIPTION	KEY NO.	PART NO.	DESCRIPTION
1	-----	Transaxle Peerless, Model 204-506B (Order parts from transaxle manufacturer)	49	532 12 32-05	Retainer, Belt
2	532 14 66-82	Spring, Brake Return	50	872 11 06-12	Bolt Carr. Sh. 3/8-16 x 1-1/2 Gr. 5
3	532 12 36-66	Pulley, Transaxle	51	873 68 06-00	Nut, Crownlock 3/8-16
4	812 00 00-28	Ring, Retainer	52	873 68 05-00	Nut, Crownlock 5/16-18
5	532 12 15-20	Strap, Torque	53	532 10 57-10	Link, Clutch
6	817 06 05-12	Screw, 5/16-18 x 3/4 SMGML	55	532 10 57-09	Spring, Return, Clutch
7	532 16 22-40	Bracket, T/A, Saddle Shift	56	817 06 06-20	Screw 3/8-16 x 1-1/4
8	532 13 16-79	Rod, Shifter	57	532 13 08-01	V-Belt, Drive
10	876 02 04-16	Pin, Cotter 1/8 x 1	59	532 16 96-91	Keeper Belt Center Span
11	532 10 57-01	Washer, Shift Plate	61	817 12 06-14	Screw, 3/8-16 x .875
12	819 15 12-16	Washer 15/32 x 3/4 x 16	62	532 00 81-56	Cover, Foot Pedal
13	874 55 04-12	Bolt 1/4-28 UNF Gr. 8 w/Patch	63	532 18 02-19	Pulley, Engine
14	810 04 04-00	Washer Lock	64	871 17 07-64	Bolt, Hex 7/16-20 x 4 Gr. 5
16	873 80 05-00	Nut Lock Hx W/Ins. 5/16-18	65	810 04 07-00	Washer, Lock Hvy Hlcl Spr 7/16
18	874 78 06-16	Bolt, Fin Hex 3/8-16 Unc x 1 Gr. 5	66	532 15 47-78	Keeper, Belt Engine F-Proof
19	873 80 06-00	Locknut 3/8-16	70	532 18 02-18	Guide Belt Mower Drive RH
21	532 10 69-33	Knob	74	532 13 70-57	Spacer, Split
22	532 13 08-04	Rod, Brake	75	532 12 17-49	Washer 25/32 x 1-1/4 x 16 Ga.
24	873 35 06-00	Nut, Hex Jam 3/8-16	76	812 00 00-01	E-Ring
25	532 10 68-88	Spring, Rod, Brake	77	532 12 35-83	Key Square
26	819 13 13-16	Washer 13/32 x 13/16 x 16 Gauge	78	532 12 17-48	Washer 25/32 x 1-5/8 x 16 Ga.
27	876 02 04-12	Pin, Cotter 1/8 x 3/4	79	532 00 22-28	Key Woodruff #9 3/16 x 3/4
28	532 17 57-65	Rod, Brake, Park	96	532 12 47-88	Retainer Spring 1" Ziinc/Cad
29	532 07 16-73	Cap, Plunger	112	819 09 12-10	Washer 9/32 x 3/4 x 10 Ga.
30	532 17 49-73	Bracket, Transaxle, L.H.	113	532 12 72-85	Strap Torque L.H. Lt
32	874 76 05-12	Bolt Hex Hd 5/16-18 UNC x 3/4	116	872 14 06-08	Bolt, RdHd Sq Neck 3/8-16 x 1
34	532 17 55-78	Shaft, Foot Pedal	120	873 90 06-00	Nut Lock Flg 3/8-16
35	532 12 01-83	Bearing Nylon	145	874 49 05-40	Bolt, Hex Flghd 5/16-18 Gr. 5
36	819 21 16-16	Washer 21/32 x 1 x 16 Gauge	150	532 17 54-56	Spacer Retainer
37	532 00 15-72	Pin, Roll 3/16 x 1	151	819 13 32-10	Washer 13/32 x 2 x 10 Ga.
38	532 17 91-14	Idler, Pulley Composite	170	532 17 83-94	Keeper, Belt, Transaxle GD.
39	874 76 06-48	Bolt, RDHD 3/8-16unc x 3 Gr. 5	202	872 11 06-14	Bolt Carr Sh 3/8-16 x 1-3/4 Gr. 5
41	532 17 55-56	Keeper, Belt	212	532 14 52-12	Nut Hex Flange Lock
47	532 12 77-83	Pulley, Idler	263	817 00 06-12	Screw Hex Wsh Thdr. 3/8-16 x 3/4
48	532 15 44-07	Bellcrank Asm Clutch	269	532 18 24-02	Guard Muffler RH
			250	817 06 06-12	Screw 3/8-16 x .75

NOTE: All component dimensions give in U.S. inches.
1 inch = 25.4 mm.

REPAIR PARTS

TRACTOR -- MODEL NO. BM11M91 (BM11M92A), PRODUCT NO. 964 79 45-00
SEAT

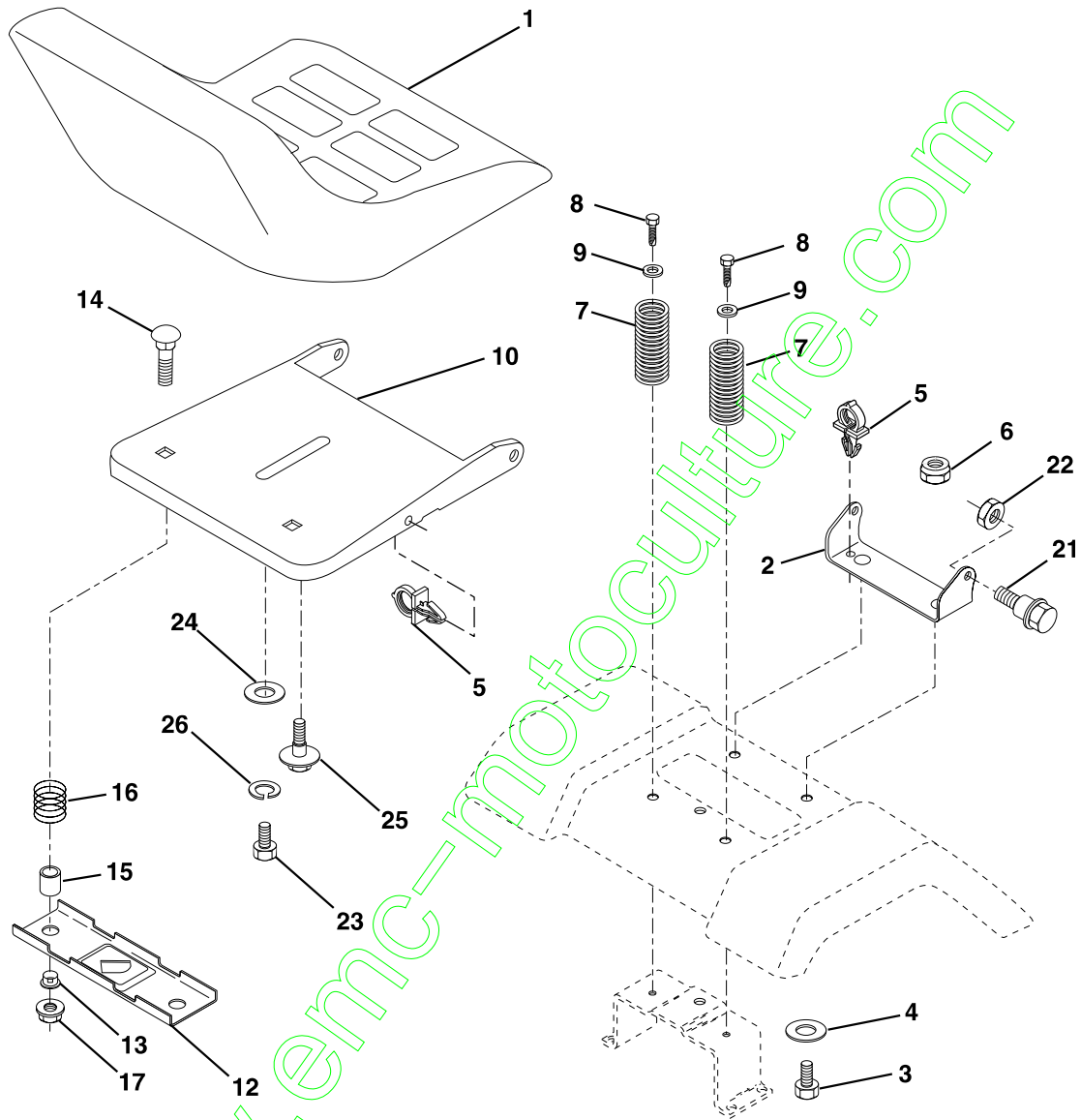

KEY NO.	PART NO.	DESCRIPTION
1	532 12 74-26	Seat
2	532 14 05-51	Bracket, Pivot, Seat
3	871 11 06-16	Fin, Hex 3/8-16unc x 1
4	819 13 16-10	Washer 13/32 x 1 x 10 Ga.
5	532 14 50-06	Clip, Push-in
6	873 80 06-00	Nut
7	532 12 41-81	Spring, Seat
8	817 00 06-16	Screw, 3/8-16 x 1.5 SMGML Tap/R
9	819 13 16-14	Washer 13/32 x 1 x 14 Ga.
10	532 18 24-93	Pan, Seat
12	532 12 12-46	Bracket, Mounting, Switch, Seat
13	532 12 12-48	Bushing, Nylon

KEY NO.	PART NO.	DESCRIPTION
14	872 05 04-12	Nut, Crownlock 1/4-20 x 1-3/8
15	532 13 43-00	Spacer, Split
16	532 12 12-50	Spring
17	532 12 39-76	Nut, Lock, Flange 1/4 Gr. 5
21	532 17 18-52	Bolt, Shoulder 5/16-18 UNC-2A
22	873 80 05-00	Nut
23	871 11 08-14	Bolt Hex
24	819 17 19-12	Washer 17/32 x 1-3/16 x 12 Ga.
25	532 12 70-18	Bolt Shoulder 5/16-18 x .62
26	810 04 08-00	Washer Lock Hvy Hclc Spr 1/2

NOTE: All component dimensions given in U.S. inches
1 inch = 25.4 mm

REPAIR PARTS

TRACTOR - - MODEL NO. BM11M91 (BM11M92A), PRODUCT NO. 964 79 45-00
DECALS

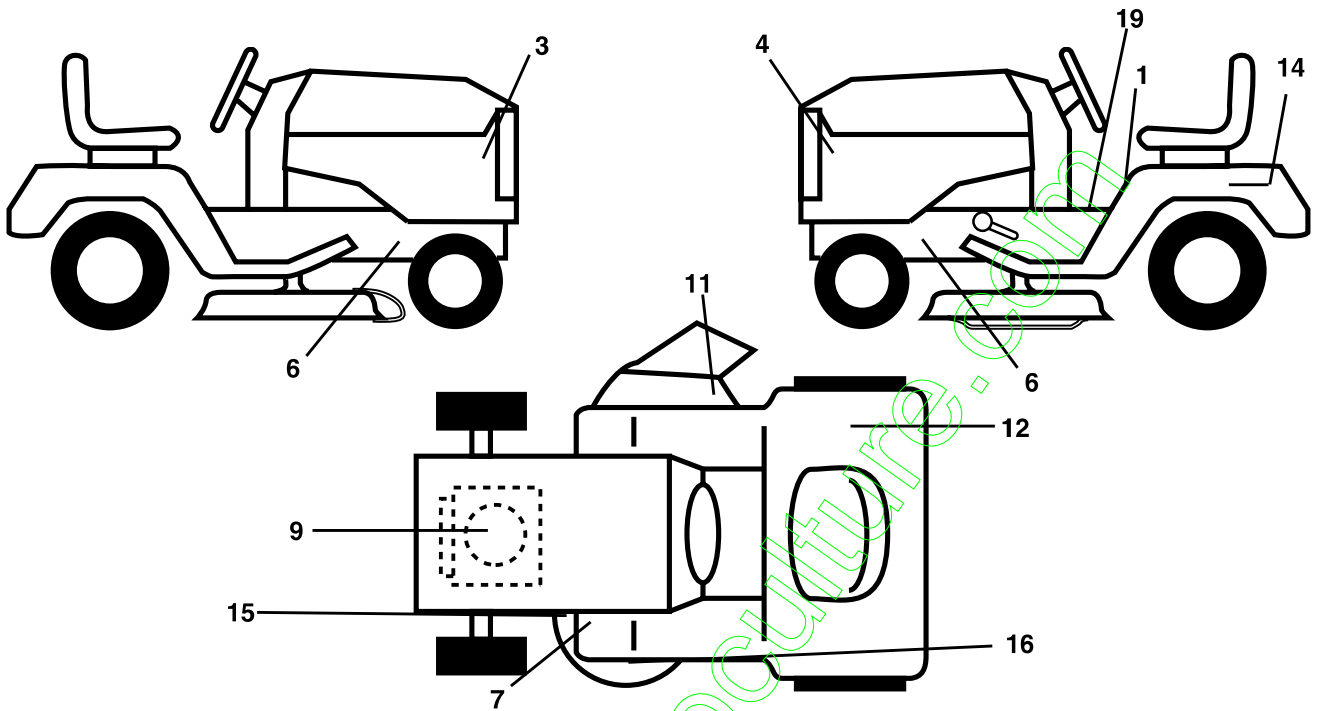

KEY NO.	PART NO.	DESCRIPTION	KEY NO.	PART NO.	DESCRIPTION
1	532 14 54-98	Decal, Instruction, Operation	15	532 13 68-32	Decal, V-Belt
3	532 17 60-87	Decal, Hood R.H.	16	532 13 49-99	Decal, Deck
4	532 17 60-88	Decal Hood. L.H.	19	532 14 08-37	Decal, Parking Brake
6	532 15 97-36	Decal, Chassis Hot Muffler	--	532 13 83-11	Decal, Handle, Lift, Height Adjust (Lift Handle)
7	532 15 97-37	Decal, Brake/Clutch Symbol LT	--	532 16 25-98	Decal, Drawbar Load Limit
9	532 18 47-64	Decal, HP Engine	--	532 18 51-49	Manual, (Euro) Operator's
11	532 18 21-66	Decal, Mower Cutoffinger Symbol	--	532 18 54-00	Manual, Repair Parts
12	532 18 04-32	Decal 100 DB/CE	--	532 17 99-23	Manual, (Port) Operator's
14	532 14 50-05	Decal, Btry Dngr/Psn P/L Sym	--	532 17 99-24	Manual, (Polish) Operator's

TIRES AND WHEELS

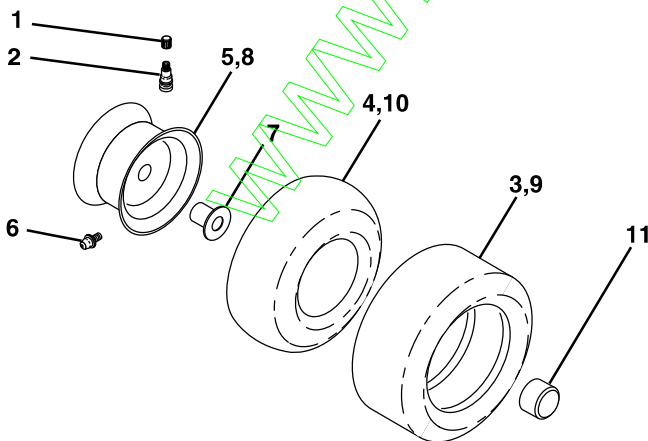

KEY NO.	PART NO.	DESCRIPTION
1	532 05 91-92	Cap, Valve
2	532 06 51-39	Stem, Valve
3	532 12 41-57	Tire Front
4	532 05 99-04	Tube, Front (not furnished)
5	532 18 33-37	Rim, Asm. Front
6	532 12 49-57	Grease Fitting (rear tire only)
7	532 00 90-40	Bearing, Flange (front tire only)
8	532 18 33-38	Rim, Asm. Rear
9	532 12 39-69	Tire, Rear
10	532 12 49-26	Tube, Rear (not furnished)
11	532 17 50-39	Cap, Axle
--	532 14 43-34	Sealant, Tire (10 oz. Tube)

NOTE: All component dimensions given in U.S. inches
1 inch = 25.4 mm

REPAIR PARTS

TRACTOR -- MODEL NO. BM11M91 (BM11M92A), PRODUCT NO. 964 79 45-00
STEERING WHEEL

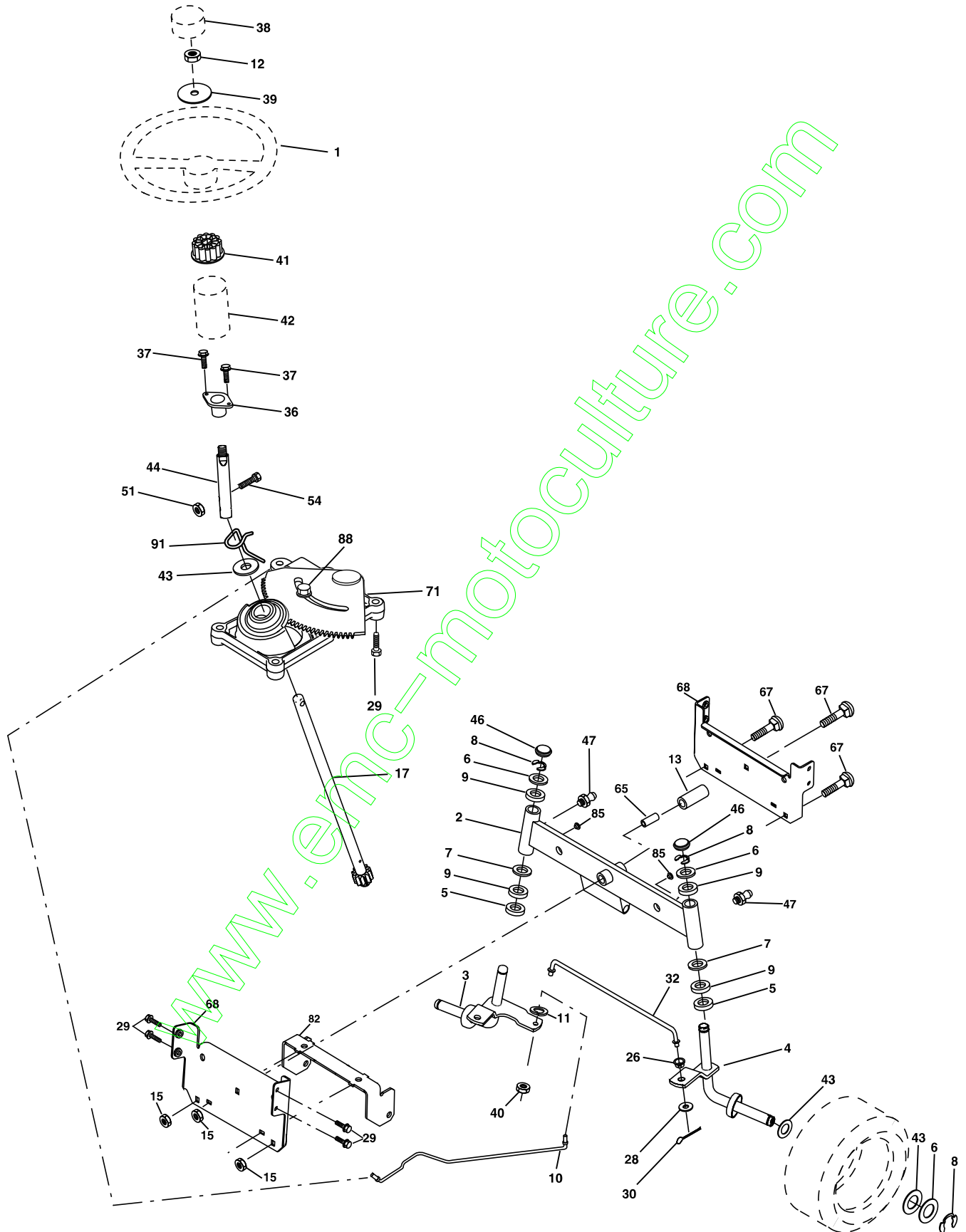

REPAIR PARTS

TRACTOR - - MODEL NO. BM11M91 (BM11M92A), PRODUCT NO. 964 79 45-00
STEERING WHEEL

KEY NO.	PART NO.	DESCRIPTION
1	532 17 71-82	Wheel Steering
2	532 17 51-31	Axle Asm Front
3	532 16 98-40	Spindle Asm LH
4	532 16 98-39	Spindle Asm RH
5	532 12 49-31	Bearing, Race, Thrust Hardened
6	532 12 17-48	Washer 25/32 X 1-5/8 X 16 Ga
7	819 27 20-16	Washer 27/32 X 1-1/4 X 16 Ga
8	812 00 00-29	Ring Klip
9	532 12 49-37	Bearing
10	532 17 51-21	Link Drag
11	810 04 06-00	Washer Lock Hvy Hicl Spr 3/8
12	873 94 08-00	Nut Hex Jam Toplock 1/2-20 Unf
13	532 13 65-18	Spacer Brg. Axle Front
15	532 14 52-12	Nut Hexflange Lock
17	532 18 06-41	Shaft Asm
26	532 12 68-47	Bushing Link Drag Blk Lr
28	819 13 14-16	Washer 13/32 x 7/8 x 16 Ga.
29	817 06 06-12	Screw 3/8-16x3/4 SMGML Tap/R
30	876 02 04-12	Pin Cotter 1/8 x 3/4 CAD
32	532 13 04-65	Rod Connecting
36	532 15 50-99	Bushing Steering
37	532 15 29-27	Screw TT #10-32 X 5 x 3/8 Flange
38	532 17 71-83	Cap Wheel Steering
39	819 18 38-12	Washer 9/16 ID X 2-3/8 OD 12 Ga
40	532 12 47-01	Nut Lock Center 3/8-24 Unf
41	532 10 07-11	Adapter Wheel Strg
42	532 16 96-33	Boot Steering
43	532 12 17-49	Washer 25/32 X 1 1/4 X 16 Ga
44	532 18 06-40	Extension Steering
46	532 12 12-32	Cap Spindle
47	532 18 32-26	Fitting Grease
51	873 54 04-00	Nut Crownlock 1/4-28
54	871 13 04-20	Bolt Hex 1/4-28 Unf x 1-1/4 Gr. 8
65	532 16 03-67	Spacer Brace Axle
67	872 14 06-18	Bolt RDHD SQ 3/8-16UNC x 2-1/4
68	532 16 98-27	Brace Axle
71	532 17 51-46	Steering Asm
82	532 16 98-35	Bracket Susp. Chassis Front
85	532 13 38-35	Fastener Christmas Tree
88	532 17 51-18	Bolt Shoulder 7/16-20unc
91	532 17 55-53	Clip Steering

NOTE: All component dimensions given in U.S. inches
1 inch = 25.4 mm

REPAIR PARTS

TRACTOR -- MODEL NO. BM11M91 (BM11M92A), PRODUCT NO. 964 79 45-00
ENGINE

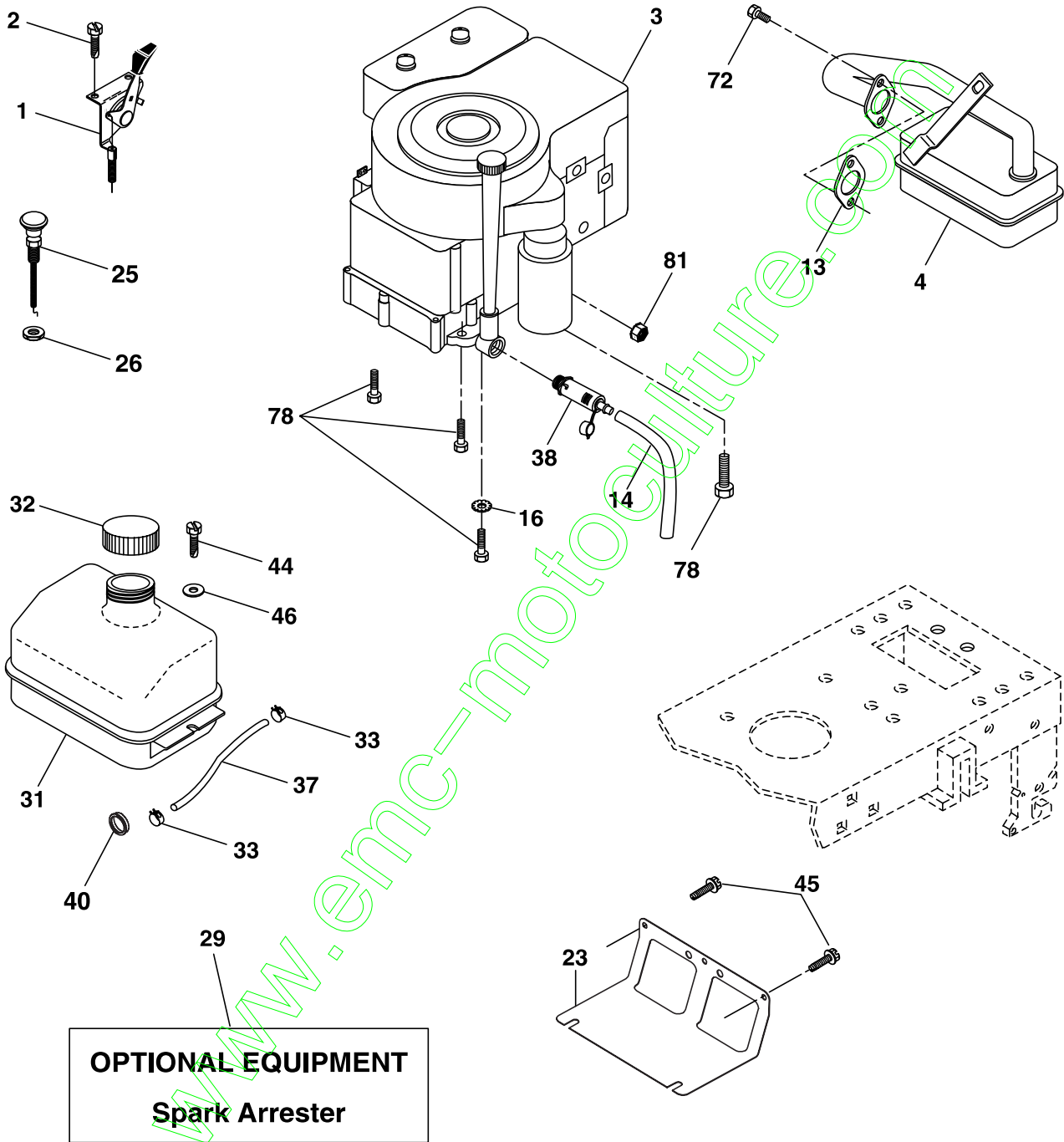

REPAIR PARTS

TRACTOR - - MODEL NO. BM11M91 (BM11M92A), PRODUCT NO. 964 79 45-00
ENGINE

KEY NO.	PART NO.	DESCRIPTION
1	532 17 05-51	Control Th/ch
2	817 72 04-08	Screw Hex Thd Cut 1/4-20 x 1/2
3	-----	Engine, B&S Model 21A807 Order parts from engine manufacturer
4	532 17 97-58	Muffler Exhaust
13	532 16 52-91	Gasket Muffler
14	532 14 84-56	Tube Drain Oil Easy
16	811 05 06-00	Washer Lock Ext Tooth 3/8
23	532 16 98-37	Shield BRN/DBR Guard
25	532 18 09-45	Control Choke
26	873 92 06-00	Nut Keps 3/8-24
29	532 13 71-80	Kit Spark Arrestor (Flat Scrn)
31	532 18 49-00	Tank Fuel Front
32	532 14 05-27	Cap Asm Fuel
33	532 12 34-87	Clamp Hose Blk
37	532 13 70-40	Line Fuel
38	532 18 16-54	Plug Easy Oil Drain
40	532 12 40-28	Bushing Snap Nyl Blk Fuel Line
44	817 67 04-12	Screw Hexwsh Thdrol 1/4-20x3/4
45	817 00 06-12	Screw Hex Wsh Thdrol 3/8-16
46	819 09 14-16	Washer 9/32 X 7/8 X 16 Ga
72	532 18 39-06	Screw Socket Head 5/16-18 x 1
78	817 06 06-20	Screw 3/8-16x1-1/4 SMGML Tap/R
81	873 51 04-00	Nut Keps Hex 1/4-20 UNC

NOTE: All component dimensions given in U.S. inches.
1 inch = 25.4 mm.

REPAIR PARTS

TRACTOR -- MODEL NO. BM11M91 (BM11M92A), PRODUCT NO. 964 79 45-00
MOWER DECK

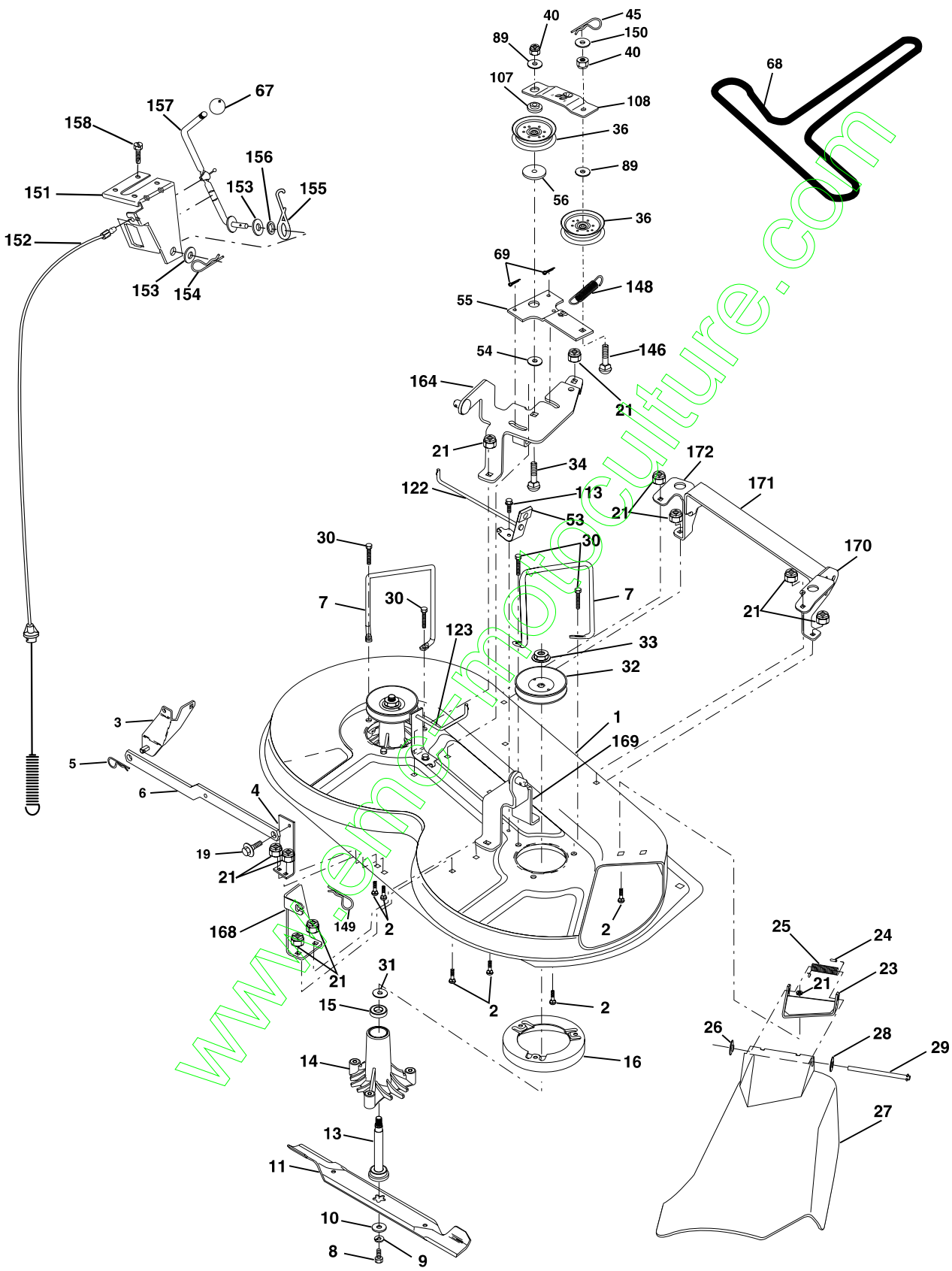

REPAIR PARTS

TRACTOR - - MODEL NO. BM11M91 (BM11M92A), PRODUCT NO. 964 79 45-00
MOWER DECK

KEY NO.	PART NO.	DESCRIPTION	KEY NO.	PART NO.	DESCRIPTION
1	532 17 45-95	Deck Asm Weldment	55	532 13 38-40	Arm, Idler Assembly
2	872 14 05-06	Bolt	56	532 16 57-23	Spacer, Retainer
3	532 13 80-17	Asm., Bar, Anti-Sway	67	532 10 69-32	Knob Rd 3/8-16 Plstc Thds Blk
4	532 17 56-54	Bracket Sway Bar 36"	68	532 18 02-13	V-Belt, Mower
5	532 12 46-70	Spring, Retainer	69	532 12 47-88	Retainer Spring 1"
6	532 17 80-24	Bar Sway Deck	89	819 13 16-12	Washer 13/32 x 1 x 12 Ga.
7	532 14 06-08	Keeper Belt Lh	107	532 13 35-02	Spacer, Retainer
8	532 85 08-57	Bolt 3/8-24 x 1.25 Gr. 8	108	532 13 35-03	Stiffener, Idler Arm
9	810 03 06-00	Washer, Lock	113	817 49 05-08	Screw Thdrol 5/16-18 x 1/2
10	532 14 02-96	Washer, Hardened	122	532 17 45-05	Rod, Brake, LH
11	532 13 84-96	Blade, Mower, Hi Lift	123	532 17 45-04	Rod, Brake, RH
--	532 14 01-01	Blade, 36: mulching (For Mulching mowers only)	146	532 16 58-91	Bolt Carriage Idler
13	532 13 76-45	Asm., Shaft, Mandrel, Vented	148	532 16 90-22	Spring Return Idler
14	532 12 87-74	Housing, Mandrel, Vented	149	532 16 58-98	Retainer Spring Yelow Zinc
15	532 11 04-85	Bearing, Ball, Mandrel	150	819 09 12-16	Washer 9/32 x 3/4 x 16 Ga.
16	532 17 44-93	Stripper, Mower	151	532 16 96-70	Bracket Clutch Cable
19	532 13 28-27	Bolt, Shoulder	152	532 17 60-79	Clutch Cable 38"/42"
21	873 68 05-00	Nut, Crownlock 5/16 - 18 UNC	153	532 16 96-74	Washer Flat 3/8" Type B
23	532 13 66-31	Bracket, Deflector	154	532 16 96-75	Spring Retainer
24	532 10 53-04	Cap, Sleeve	155	532 16 96-71	Spring Retention Lvr Cltch Cab
25	532 12 37-13	Spring, Torsion, Deflector	156	532 16 96-72	Spacer Clutch Cable 3/8"
26	532 11 04-52	Washer, Lock	157	532 16 96-69	Rod Clutch Cable 3/8"
27	532 17 61-62	Deflector, Shield	158	817 72 04-08	Screw Hex Thd Cut 1/4-20 x 1/2
28	819 11 10-16	Washer 11/32 x 5/8 x 16 Ga.	164	532 17 49-76	Bracket Asm Support Susp 36"
29	532 12 19-80	Rod, Hinge	168	532 17 23-77	Bracket Deck Cable 36"
30	532 17 39-84	Screw Hex Thdrol	169	532 17 49-77	Bracket Asm Suspension
31	532 12 99-63	Washer, Spacer	170	532 17 23-59	Bracket Suspension RF
32	532 15 35-31	Pulley, Mandrel	171	532 16 52-37	Brace Support Susp Frt
33	532 17 83-42	Nut Flange Top Lock	172	532 17 23-55	Brace Suspension LF
34	872 11 06-14	Bolt Rdhd 3/8-16 x 1-3/4	--	532 13 07-94	Mandrel Asm Service (Includes Housing, Shaft and Shaft Hardware Only-Pulley Not Included)
36	532 13 14-94	Pulley, Idler, Flat	--	532 18 13-76	Replacement Mower, Complete
40	873 68 06-00	Nut, Crownlock 3/8 - 16 UNC			
45	532 12 47-88	Retainer Spring 1; Zinc/Cad			
53	532 13 08-40	Brake Assembly			
54	532 17 85-15	Washer, Hardened			

NOTE: All component dimensions given in U.S. inches
1 inch = 25.4 mm

REPAIR PARTS

TRACTOR -- MODEL NO. BM11M91 (BM11M92A), PRODUCT NO. 964 79 45-00
MOWER LIFT

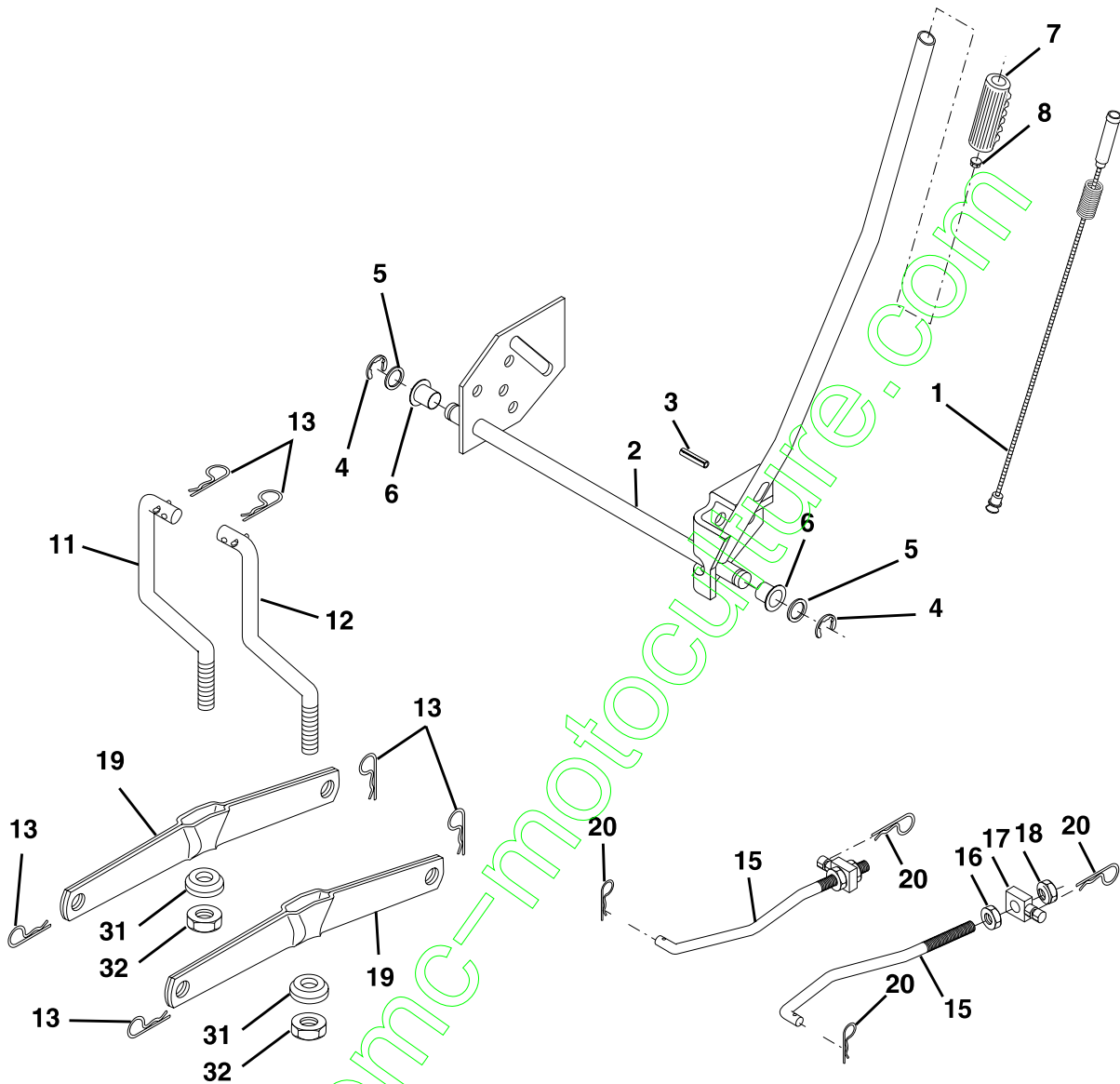

KEY NO.	PART NO.	DESCRIPTION
1	532 15 94-60	Wire Asm. Inner/Sprg w/Plunger
2	532 15 94-71	Shaft, Asm., Lift R/H
3	532 10 57-67	Pin, Groove
4	812 00 00-02	Ring, E #5133-62
5	819 21 16-21	Washer 21/32 x 1 x 21 Ga.
6	532 12 01-83	Bearing, Nylon
7	532 10 94-13	Grip Handle Bicycle Matte Blk
8	532 12 45-26	Button, Plunger
11	532 13 98-65	Link, Lift, Lh
12	532 13 98-66	Link, Lift, Rh
13	532 12 46-70	Spring, Retainer

KEY NO.	PART NO.	DESCRIPTION
15	532 17 32-88	Link, Front
16	873 35 08-00	Nut, Jam, Hex 1/2-13 Unc
17	532 17 56-89	Trunnion
18	873 80 08-00	Nut, Lock w/Wsh 1/2-13 Unc
19	532 13 98-68	Arm, Suspension, Rear
20	532 16 35-52	Spring, Retainer Zinc
31	532 16 98-65	Bearing, Pvt Lft
32	873 54 06-00	Nut Crownlock 3/8-24

NOTE: All component dimensions given in U.S. inches
1 inch = 25.4 mm

www.emc-motoculture.com

LIMITED WARRANTY

The Manufacturer warrants to the original consumer purchaser that this product as manufactured is free from defects in materials and workmanship. For a period of two (2) years from date of purchase by the original consumer purchaser, we will repair or replace, at our option, without charge for parts or labor incurred in replacing parts, any part which we find to be defective due to materials or workmanship. This Warranty is subject to the following limitations and exclusions.

1. This warranty does not apply to the engine. Please contact your nearest dealer where they will send the machine to the engine manufacturer.
2. Transportation charges for the movement of any power equipment unit or attachment are the responsibility of the purchaser. Transportation charges for any parts submitted for replacement under this warranty must be paid by the purchaser unless such return is requested by your dealer.
3. **Battery Warranty:** On products equipped with a Battery, we will replace, without charge to you, any battery which we find to be defective in manufacture, during the first ninety (90) days of ownership. After ninety (90) days, we will exchange the Battery, charging you 1/12 of the price of a new Battery for each full month from the date of the original sale. Battery must be maintained in accordance with the instructions furnished.
4. The Warranty period for any products used for rental or commercial purposes is limited to 90 days from the date of original purchase.
5. This Warranty applies only to products which have been properly assembled, adjusted, operated, and maintained in accordance with the instructions furnished. This Warranty does not apply to any product which has been subjected to alteration, misuse, abuse, improper assembly or installation, delivery damage, or to normal wear of the product.
6. **Exclusions:** Excluded from this Warranty are belts, blades, blade adapters, normal wear, normal adjustments, standard hardware and normal maintenance.
7. In case of any problem within the boundaries of this warranty, contact the nearest department store, indicate the model number, serial number and the date of purchase of your machine. This warranty does not apply to accidental damages. All implicit warranties are limited to the same time frames. Or contact:

E.M. Services
54 Rue Lambrechts
92400 Courbevoie
France
Telephone: (1) 46678078
Fax: (1) 46678095

THIS WARRANTY DOES NOT APPLY TO INCIDENTAL OR CONSEQUENTIAL DAMAGES. ANY IMPLIED WARRANTIES ARE LIMITED TO THE SAME TIME PERIODS STATED HEREIN.