

REPAIR PARTS MANUAL
MODEL NO. BM11M92T (BM11M92B)
Lawn Tractor

 **Electrolux**

HOW TO USE THIS MANUAL

This manual is designed to provide the customer with a means to identify the parts on his/her tractor when ordering repair parts. The illustrations may or may not represent the actual assemblies; therefore, it is not recommended to use this manual as a guide to assemble or disassemble the tractor. Some hardware and parts are drawn larger in order to more readily identify them.

Each tractor has its own model number.

The model number for your tractor can be found on the fender under the seat.

When ordering parts, always give the following information:

- Product - "Lawn Tractor"
- Model Number - BM11M92T (BM11M92B)
- Part Number
- Part Description

TABLE OF CONTENTS

SCHEMATIC	3
ELECTRICAL.....	4-5
CHASSIS AND ENCLOSURES.....	6-7
DRIVE.....	8-9
STEERING WHEEL	10-11
ENGINE.....	12-13
SEAT	14
DECALS.....	15
MOWER DECK	16-17
MOWER LIFT	18

TRACTOR - MODEL NO. BM11M92T (BM11M92B), PRODUCT NO. 964 79 45-00 SCHEMATIC

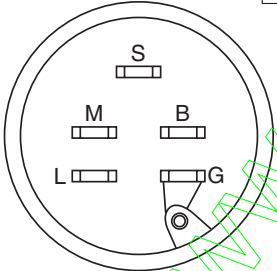
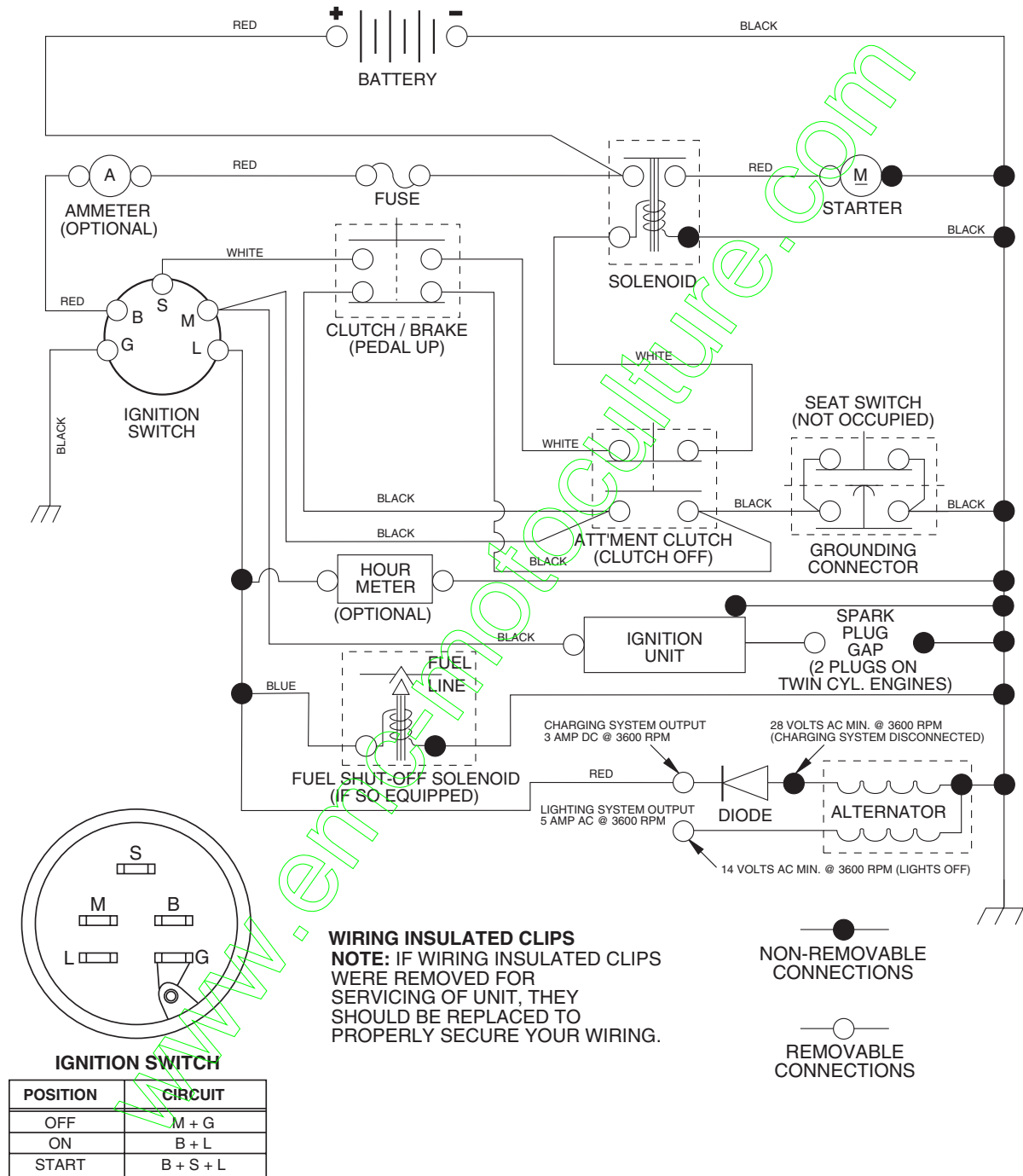

IGNITION SWITCH

POSITION	CIRCUIT
OFF	M + G
ON	B + L
START	B + S + L

REPAIR PARTS

TRACTOR - MODEL NO. BM11M92T (BM11M92B), PRODUCT NO. 964 79 45-00
ELECTRICAL

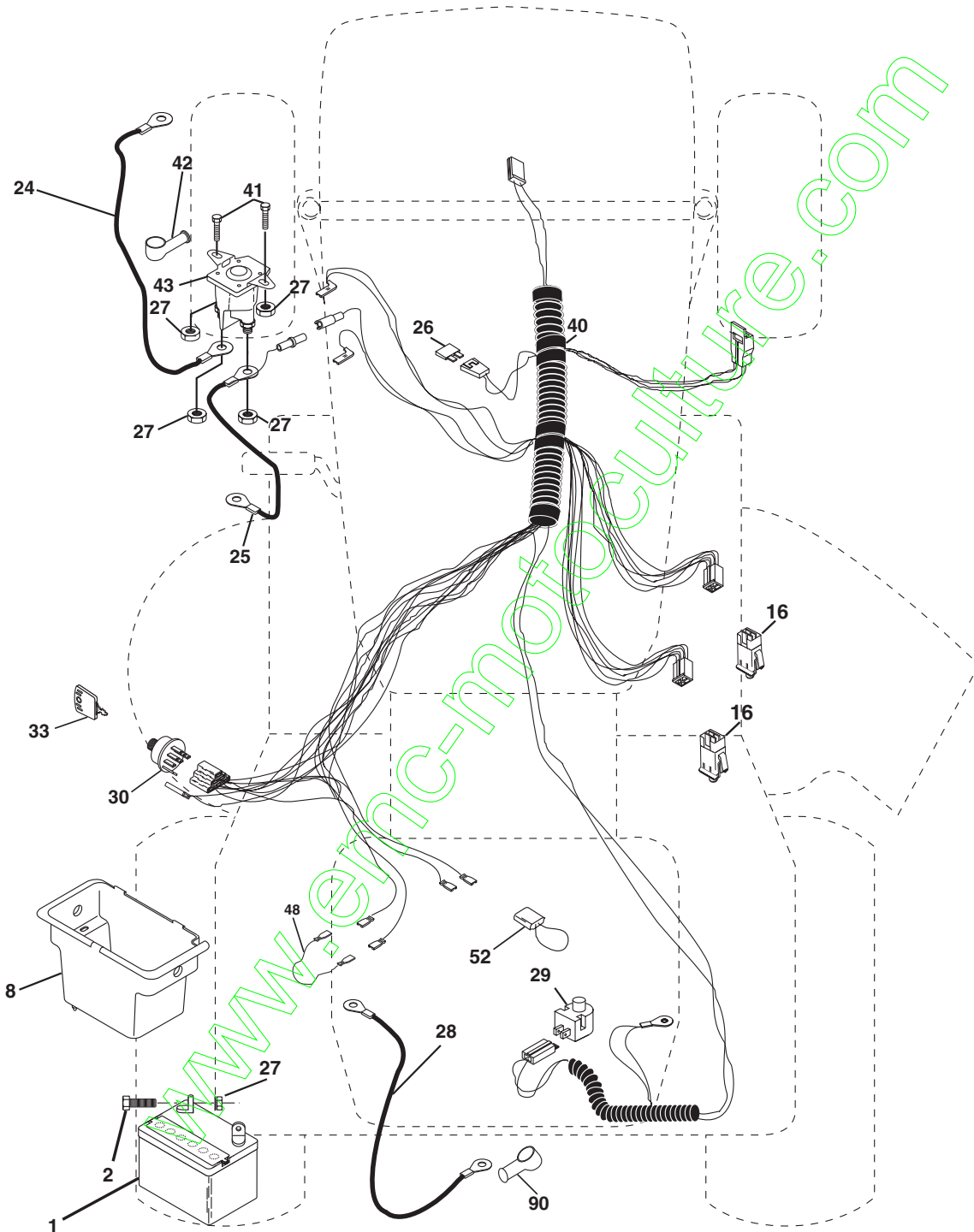

REPAIR PARTS

TRACTOR - MODEL NO. BM11M92T (BM11M92B), PRODUCT NO. 964 79 45-00
ELECTRICAL

KEY NO.	PART NO.	DESCRIPTION
1	532 16 34-65	Battery 12 Volt 25 AMP
2	874 76 04-12	Bolt Hex Hd 1/4-20 unc x 3/4
8	532 17 66-89	Box Battery
16	532 17 61-38	Switch Interlock Push-In
24	532 12 47-80	Cable Battery 6 Ga 11" red
25	532 14 61-47	Cable Battery 6 Ga 44" red w/16 wire
26	532 17 51-58	Fuse 20 AMP
27	873 51 04-00	Nut Keps Hex 1/4-20 unc
28	532 12 47-73	Cable Ground 6 Ga 12" black
29	532 12 13-05	Switch Plunger Nc Gray
30	532 17 55-67	Switch Ign
33	532 14 04-01	Key Ign Molded Generic
40	532 17 97-30	Harness Ign.
41	871 11 04-08	Bolt Blk Fin Hex 1/4 - 20 x 1/2
42	532 13 15-63	Cover Terminal Red
43	532 17 88-61	Solenoid
48	532 14 08-44	Adapter Ammeter Rectangular
52	532 14 19-40	Protection Wire Loop
90	532 18 04-49	Cover Terminal Battery

NOTE: All component dimensions given in U.S. inches.
1 inch = 25.4 mm.

REPAIR PARTS

TRACTOR - MODEL NO. BM11M92T (BM11M92B), PRODUCT NO. 964 79 45-00
CHASSIS AND ENCLOSURES

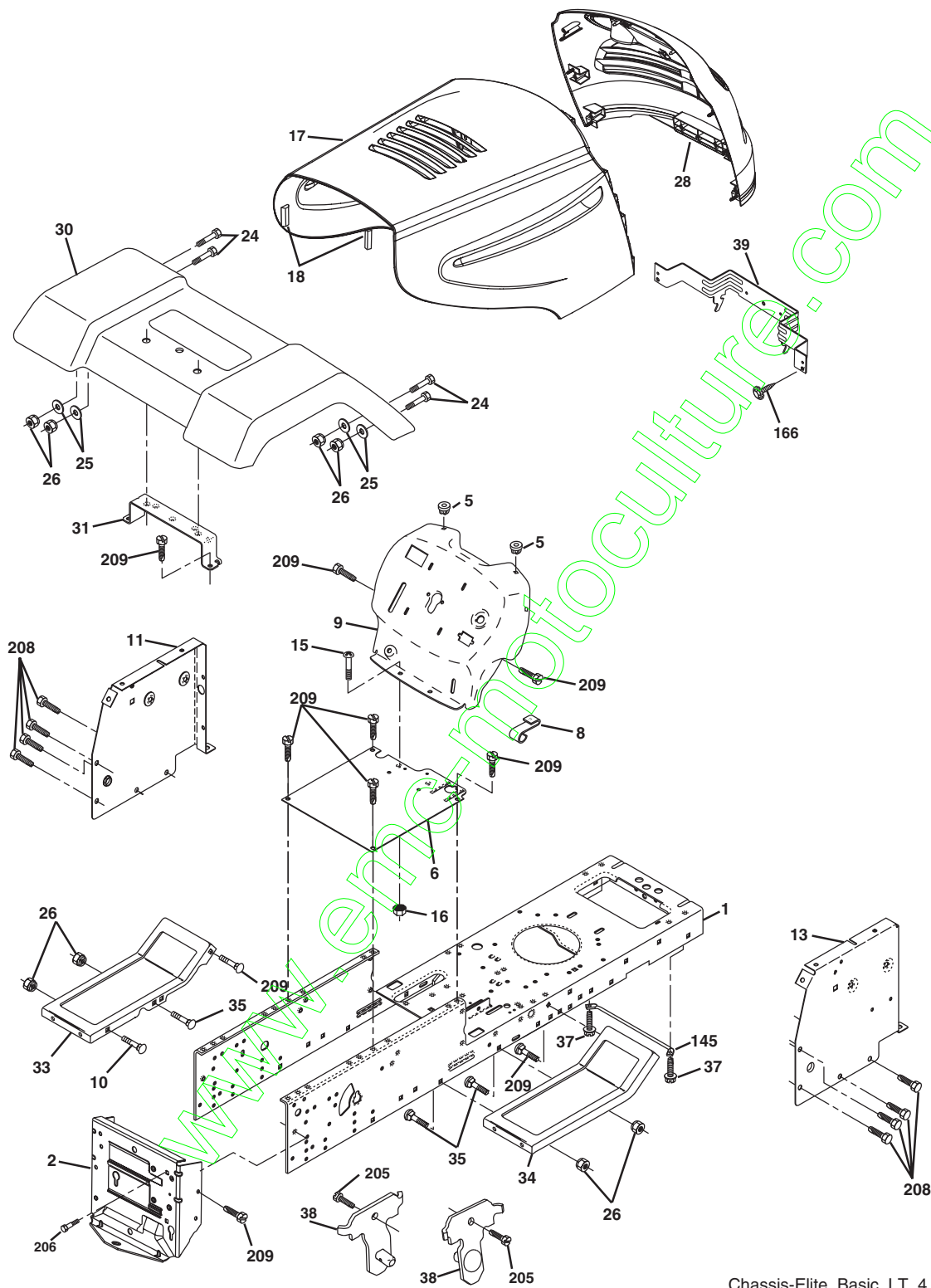

Chassis-Elite_Basic_LT_4

REPAIR PARTS

TRACTOR - MODEL NO. BM11M92T (BM11M92B), PRODUCT NO. 964 79 45-00 CHASSIS AND ENCLOSURES

KEY NO.	PART NO.	DESCRIPTION
1	532 17 46-20	Chassis Stamping
2	532 17 65-54	Drawbar
5	532 15 52-72	Bumper Hood/Dash
6	532 18 12-71	Saddle, Flat
8	532 15 51-38	Clip Retainer
9	532 18 54-80	Dash P/L
10	872 14 06-08	Bolt Carriage 3/8-16 x 1
11	532 17 49-96	Panel Dash Lh
13	532 18 69-52	Panel Dash Rh
15	874 18 05-12	Screw Mach. TRHD 5/16-18 unc x 3/4
16	873 51 05-00	Nut Keps 5/16-18unc
17	532 18 67-07	Hood
18	532 12 69-38	Bumper Hood
24	874 78 06-16	Bolt Fin Hex 3/8-16unc x 1 Gr. 5
25	819 13 13-12	Washer 13/32 X 13/16 x 12 Ga
26	873 80 06-00	Nut Lock Hex W/Ins 3/8-16 Unc
28	532 18 67-18	Grille/Lens
30	532 18 25-35	Fender Footrest STLT Pnt
31	532 13 66-19	Bracket Support Fender
33	532 18 11-93	Footrest LH
34	532 18 11-94	Footrest RH
35	872 11 06-06	Bolt RDHD SHT SQNK 3/8-16 x 3/4
37	817 49 05-08	Screw Thdrol 6/16-18 x 1/2 TYT
38	532 17 57-10	Bracket, Asm. Pivot, Mower Rear
39	532 17 47-14	Bracket Pivot
145	532 15 65-24	Rod Pivot Chassis/Hood
166	532 17 18-75	Screw
205	817 49 06-08	Screw Thdrol 3/8-16 x 1/2
206	532 17 01-65	Bolt Shoulder 5/16-18 TT
208	817 67 06-08	Screw Thdrol 3/8-16 x 1/2
209	817 00 06-12	Screw Thdr 3/8-16 x 3/4
--	532 00 54-79	Plug Button

NOTE: All component dimensions given in U.S. inches
1 inch = 25.4 mm

REPAIR PARTS

TRACTOR - MODEL NO. BM11M92T (BM11M92B), PRODUCT NO. 964 79 45-00
DRIVE

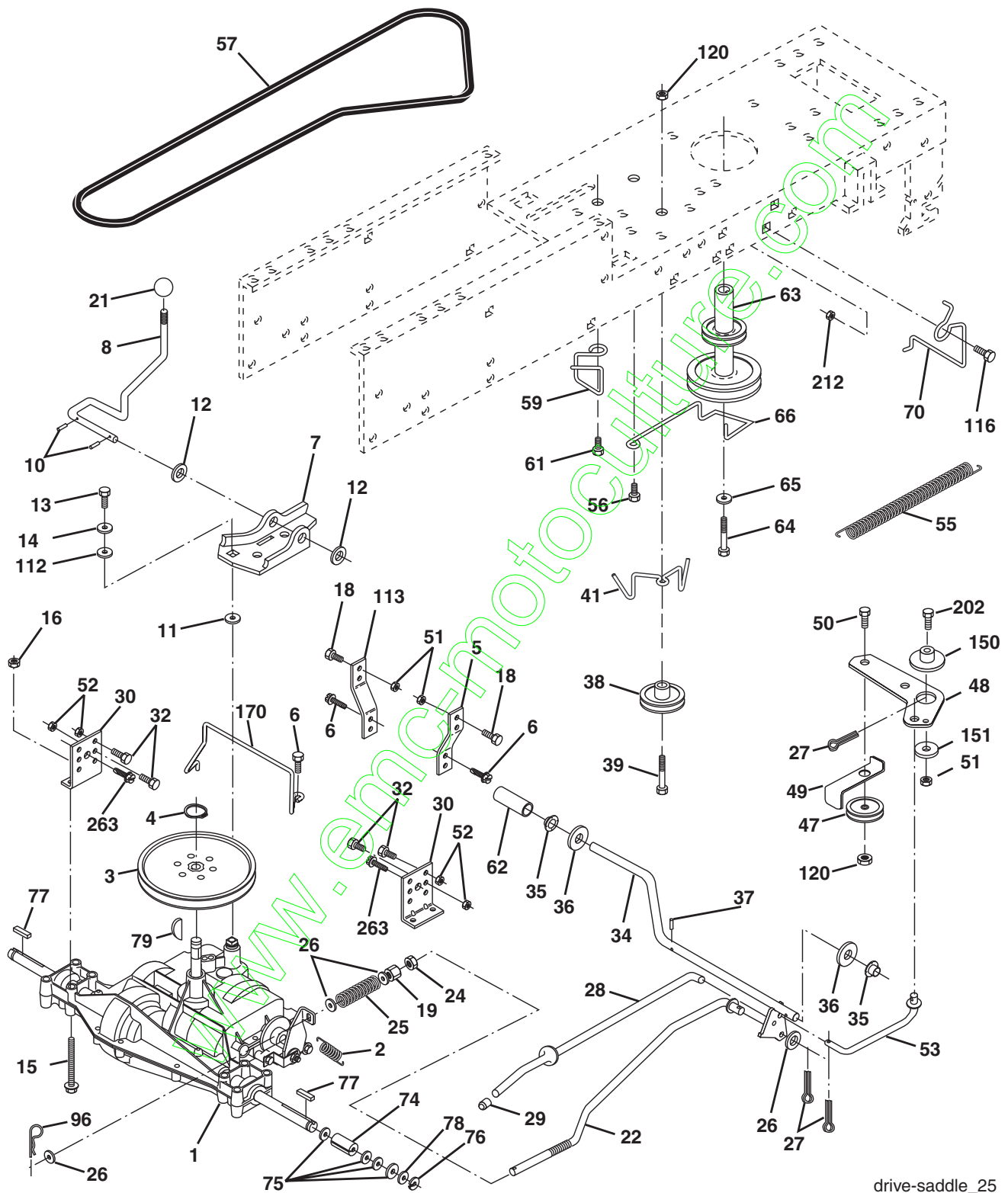

drive-saddle_25

REPAIR PARTS

TRACTOR - MODEL NO. BM11M92T (BM11M92B), PRODUCT NO. 964 79 45-00
DRIVE

KEY PART NO. NO.	DESCRIPTION	KEY PART NO. NO.	DESCRIPTION
1	----- Transaxle, Peerless 204-506B(Order Parts From Transaxle Manufacturer)	48	532 15 44-07 Bellcrank Clutch Grnd Drv Stl
2	532 14 66-82 Spring Return Brake T/a Zinc	49	532 12 32-05 Retainer Belt Style Spring
3	532 12 36-66 Pulley Transaxle 18" tires	50	872 11 06-12 Bolt Carr SH 3/8-16 x 1-1/2 Gr.5
4	812 00 00-28 Ring Retainer # 5100-62	51	873 68 06-00 Nut Crownlock 3/8-16 unc
5	532 12 15-20 Strap Torque 30 Degrees	52	873 68 05-00 Nut Crownlock 5/16-18 unc
6	817 00 05-12 Screw Thdrol 5/16-18 x 3/4 TYT	53	532 10 57-10 Link Clutch
7	532 16 22-40 Bracket Saddle Shift	55	532 10 57-09 Spring Return Clutch 6 75
8	532 13 16-79 Rod Shift	56	817 06 06-20 Screw 3/8-16 x 1-1/4
10	876 02 04-16 Pin Cotter 1/8 x 1 Cad	57	532 13 08-01 V-Belt Ground Drive 95 25
11	532 10 57-01 Washer Plate Shf 388 Sq Hole	59	532 16 96-91 Keeper Belt Span Ctr
12	819 15 12-16 Washer 15/32 x 3/4 x 16 Ga.	61	817 12 06-14 Screw 3/8-16 x .875
13	874 55 04-12 Bolt 1/4-28 Unf Gr. 8 W/Patch	62	532 00 81-56 Cover Pedal
14	810 04 04-00 Washer Lock Hvy Helical 1/4	63	532 18 02-19 Engine Pulley
15	874 49 05-44 Bolt 5/16-18 Gr. 5	64	532 17 39-37 Bolt Hex
16	873 80 05-00 Nut Lock Hex W/Ins 5/16-18	65	810 04 07-00 Washer Lock Hvy Hlcl Spr 7/16
18	874 78 06-16 Bolt, Fin Hex 3/8-16 unc x 1 Gr. 5	66	532 15 47-78 Keeper Belt Engine Foolproof
19	873 80 06-00 Nut Lock 3/8-16 unc	70	532 18 02-18 Guide Belt Mower Drive RH
21	532 10 69-33 Knob	74	532 13 70-57 Spacer Axle
22	532 13 08-04 Rod Brake Blk Zinc 26 840	75	532 12 17-49 Washer 25/32 x 1 1/4 x 16 Ga.
24	873 35 06-00 Nut Hex Jam 3/8-16 unc	76	812 00 00-01 E-ring #5133-75
25	532 10 68-88 Spring Rod Brake 2 00 Zinc	77	532 12 35-83 Key Square 2 0 x 1845/ 1865
26	819 13 13-16 Washer 13/32 x 13/16 x 16 Ga	78	532 12 17-48 Washer 25/32 x 1-5/8 x 16 Ga.
27	876 02 04-12 Pin Cotter 1/8 x 3/4 Cad	79	532 12 50-96 Key Woodruff #9 3/16 x 3/4
28	532 17 57-65 Rod Brake Parking LT/YT	96	532 12 47-88 Retainer Spring 1"
29	532 07 16-73 Cap Brake Parking Black	112	819 09 12-10 Washer 9/32 x 3/4 x 10 Ga.
30	532 17 49-73 Bracket Mtg Transaxle	113	532 12 72-85 Strap Torque LT
32	874 76 05-12 Bolt Hex Hd 5/16-18unc x 3/4	116	872 14 06-08 Bolt Rdhd Sq Neck 3/8-16 x 1
34	532 17 55-78 Shaft Asm Pedal Foot	120	873 90 06-00 Nut Lock Flg. 3/8-16
35	532 12 01-83 Bearing Nylon Blk 629 Id	150	532 17 54-56 Spacer Retainer
36	819 21 16-16 Washer 21/32 x 1 x 16 Ga.	151	819 13 32-10 Washer 13/32 x 2 x 10 Ga.
37	532 12 49-63 Pin Roll 3/16 x 1"	170	532 17 83-94 Keeper Belt T/A
38	532 17 91-14 Pulley Composite	202	872 11 06-14 Bolt 3/8-16 x 1-3/4 Gr. 5
39	872 11 06-22 Bolt 3/8-16 x 2-3/4 Gr.5	212	532 14 52-12 Nut Hex Flg Lock
41	532 17 55-56 Keeper Belt Idler Flat	263	817 00 06-12 Screw Hex Wsh THDR 3/8-16 x 3/4
47	532 12 77-83 Pulley Idler V Groove Plastic		

NOTE: All component dimensions given in U.S. inches
1 inch = 25.4 mm

REPAIR PARTS

TRACTOR - MODEL NO. BM11M92T (BM11M92B), PRODUCT NO. 964 79 45-00
STEERING ASSEMBLY

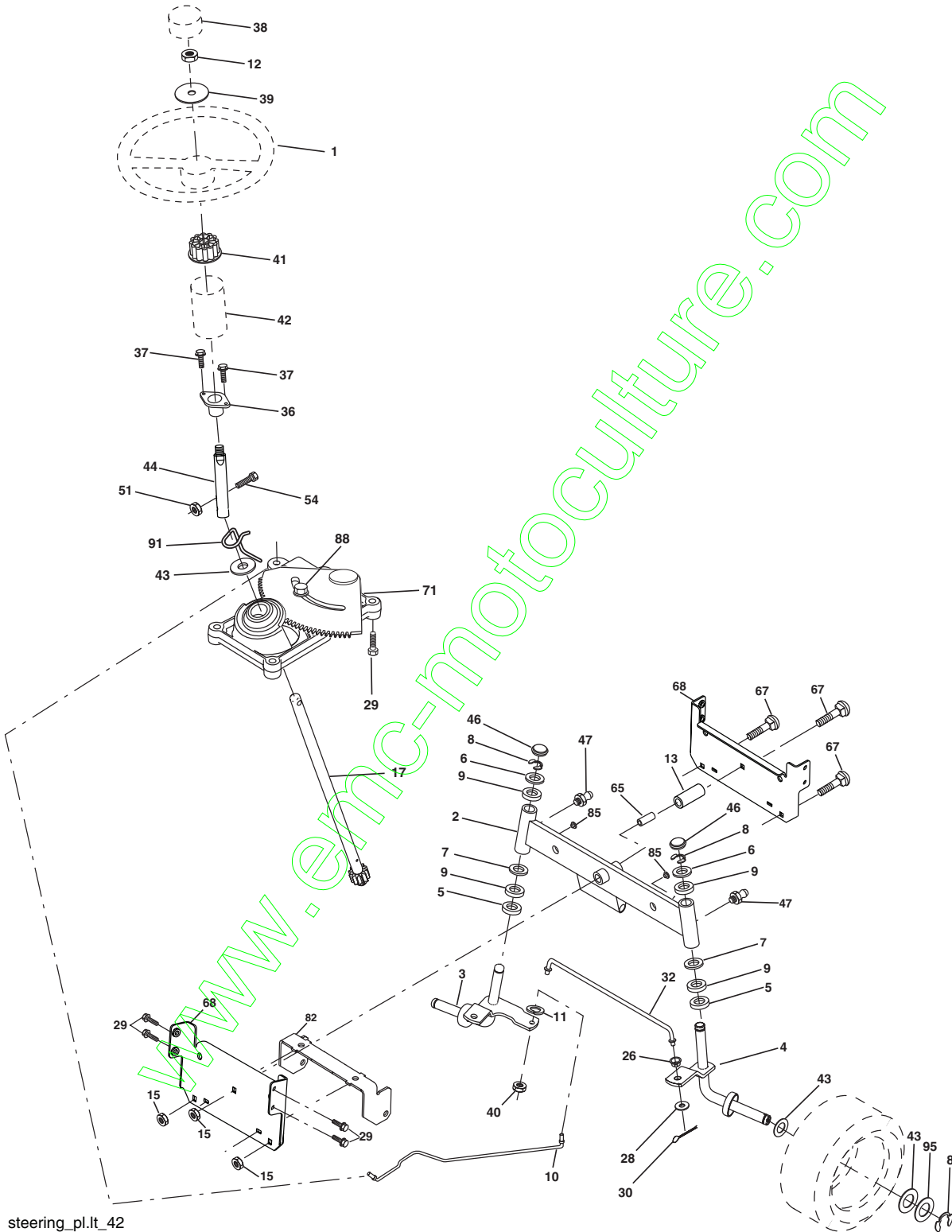

steering_pl.lt_42

REPAIR PARTS

TRACTOR - MODEL NO. BM11M92T (BM11M92B), PRODUCT NO. 964 79 45-00 STEERING ASSEMBLY

KEY NO.	PART NO.	DESCRIPTION
1	532 13 97-68	Wheel Steering
2	532 17 51-31	Axle Asm
3	532 16 98-40	Spindle Asm LH
4	532 16 98-39	Spindle Asm RH
5	532 12 49-31	Bearing Race Thrust Harden
6	532 12 17-48	Washer 25/32 x 1-5/8 x 16 Ga.
7	819 27 20-16	Washer 27/32 x 1-1/4 x 16 Ga.
8	812 00 00-29	Ring Klip #t5304-75
9	532 12 49-37	Bearing Col Strg Blk
10	532 17 51-21	Link Drag
11	810 04 06-00	Washer Lock Hvy Hlcl Spr 3/8
12	873 94 08-00	Nut Hex Jam Toplock 1/2-20 unf
13	532 13 65-18	Spacer Brg Axle Front
15	532 14 52-12	Nut Hex Flange Lock
17	532 18 06-41	Shaft Asm Strg
26	532 12 68-47	Bushing Link Drag Blk LR
28	819 13 14-16	Washer 13/32 x 7/8 x 16 Ga.
29	817 00 06-12	Screw 3/8-16 x 3/4
30	876 02 04-12	Pin Cotter 1/8 x 3/4 Cad
32	532 13 04-65	Rod Tie Wire Form 19 75 Mech
36	532 15 50-99	Bushing Strg
37	532 15 29-27	Screw
38	532 14 01-75	Insert Cap Strg Wh
39	819 18 38-12	Washer 9/16- ID x 2-3/8 OD 12 Ga.
40	873 54 06-00	Nut Crownlock 3/8-24
41	532 18 67-37	Adaptor Wheel Strg
42	532 16 96-33	Boot Steering Shaft
43	532 12 17-49	Washer 25/32 x 1-1/4 x 16 Ga.
44	532 18 06-40	Extension Steering Shaft
46	532 12 12-32	Cap Spindle Fr Top Blk
47	532 18 32-26	Fitting Grease
51	873 54 04-00	Nut Crownlock 1/4-28
54	871 13 04-20	Bolt Hex 1/4-28 unf x 1-1/4 Gr. 8
65	532 16 03-67	Spacer Brace Axle
67	872 11 06-18	Bolt, Rdhd Sqnk 3/8-16 x 2-1/4
68	532 16 98-27	Axle, Brace
71	532 17 51-46	Steering Asm.
82	532 16 98-35	Bracket Susp Chassis Front
85	532 13 38-35	Fastener Christmas Tree
88	532 17 51-18	Bolt Shoulder 7/16-20
91	532 17 55-53	Clip Steering
95	532 18 89-67	Washer Hardened

NOTE: All component dimensions given in U.S. inches.
1 inch = 25.4 mm.

REPAIR PARTS

TRACTOR - MODEL NO. BM11M92T (BM11M92B), PRODUCT NO. 964 79 45-00
ENGINE

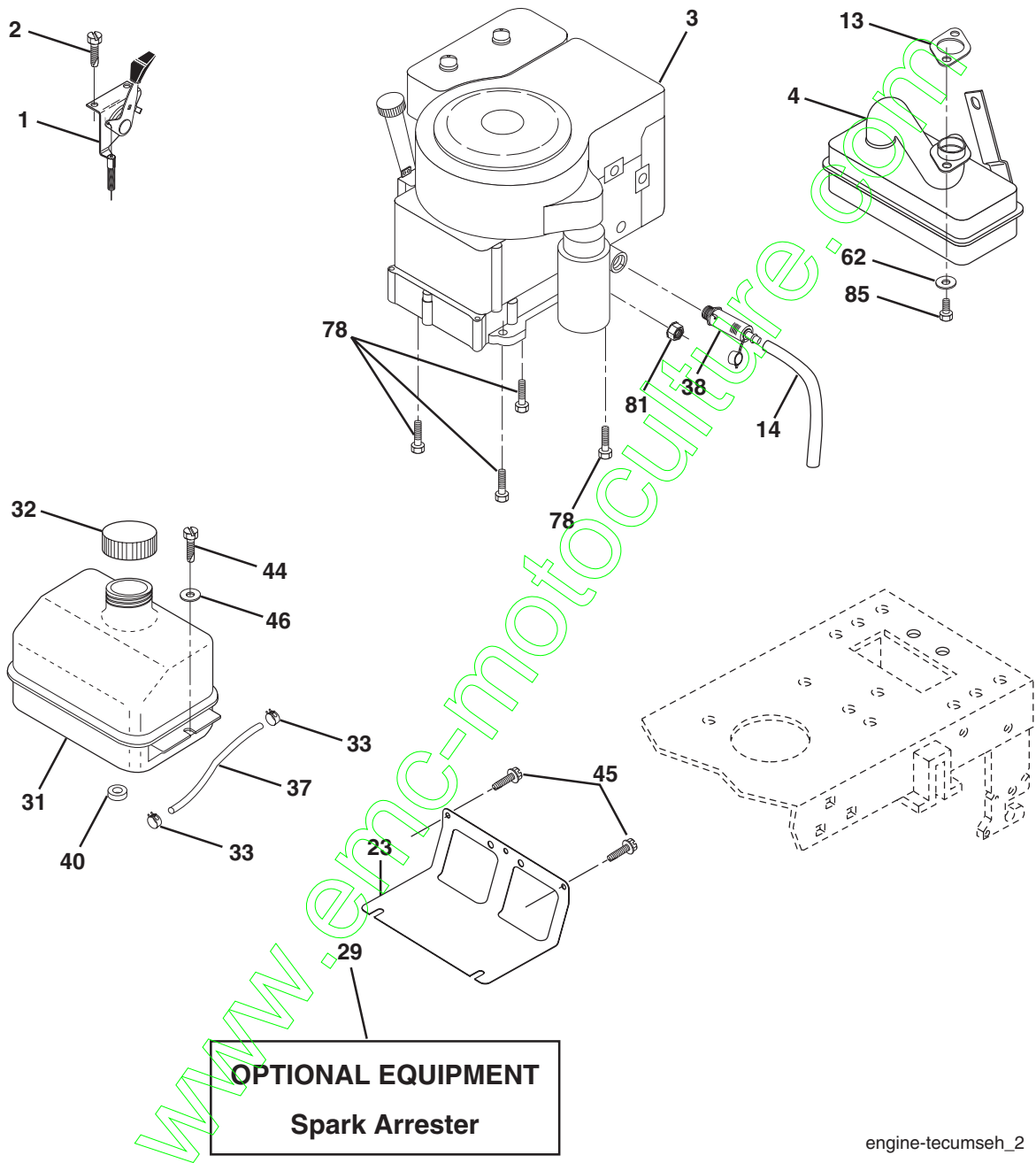

engine-tecumseh_2

REPAIR PARTS

TRACTOR - MODEL NO. BM11M92T (BM11M92B), PRODUCT NO. 964 79 45-00
ENGINE

KEY NO.	PART NO.	DESCRIPTION
1	532 17 08-64	Control Th/ch Flag
2	817 72 04-08	Screw Hex Thd Cut 1/4-20 x 1/2
3	-----	Engine Tec Model No. OHV170 (Order Parts From Engine Manufacturer)
4	532 13 73-51	Muffler LT B&S
13	532 14 92-72	Gasket Eng 1 313 Id Tin Plated
14	532 14 84-56	Tube Drain Oil Easy
23	532 16 98-37	Shield Brn/Dbr Guard
29	532 13 71-80	Kit Spark Arrestor (Flat Scrm)
31	532 18 49-00	Tank Fuel Front
32	532 14 05-27	Cap Asm Fuel W/sym Vented
33	532 12 34-87	Clamp Hose Black
37	532 13 70-40	Line Fuel 20"
38	532 18 16-54	Plug Drain Oil Easy
40	532 12 40-28	Bushing Snap Nyl Blk Fuel Line
44	817 67 04-12	Screw Hexwsh Thdrol 1/4-20 x 3/4
45	817 00 06-12	Screw Hex Wsh Thdrol 3/8-16 x 3/4
46	819 09 14-16	Washer 9/32 x 7/8 x 16 Ga.
62	810 04 05-00	Washer Lock HLCL Spr. 5/16
78	817 06 06-20	Screw 3/8-16 x 1-1/4
81	873 51 04-00	Nut 1/4-20
85	532 12 35-28	Bolt Hex Head Phillips

NOTE: All component dimensions given in U.S. inches
1 inch = 25.4 mm

REPAIR PARTS

TRACTOR - MODEL NO. BM11M92T (BM11M92B), PRODUCT NO. 964 79 45-00
SEAT ASSEMBLY

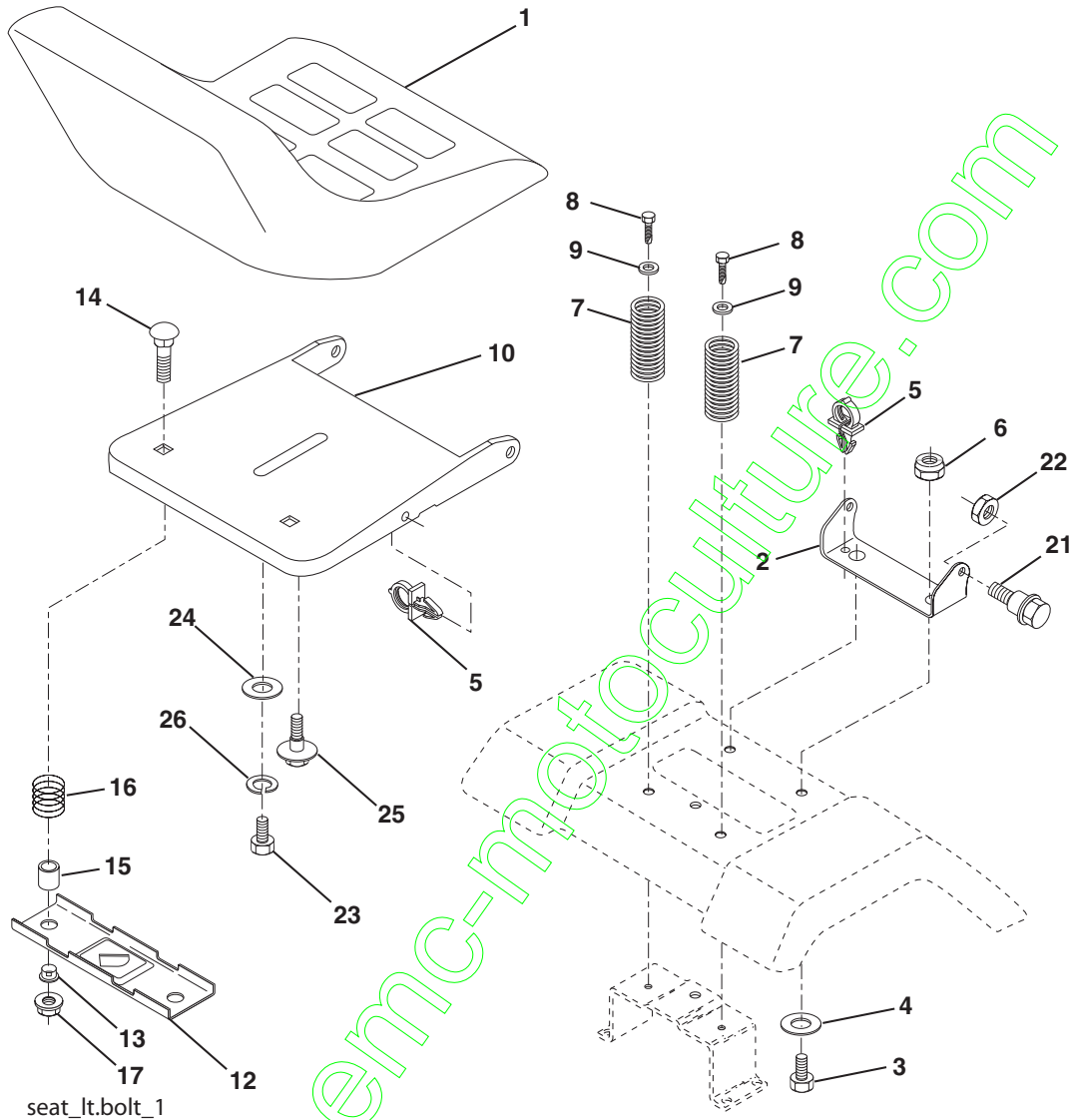

KEY NO.	PART NO.	DESCRIPTION
1	532 17 53-89	Seat
2	532 14 05-51	Bracket Pivot Seat 8 720
3	871 11 06-16	Bolt Fin Hex 3/8-16unc X 1
4	819 13 16-10	Washer 13/32 X 1 X 10 Ga
5	532 14 50-06	Clip Push-In
6	873 80 06-00	Nut Hex w/Ins. 3/8-16 Unc
7	532 12 41-81	Spring Seat Cprsn 2 250 Blk Zi
8	817 00 06-16	Screw 3/8-16 X 1-1/2
9	819 13 16-14	Washer 13/32 X 1 X 14 Ga.
10	532 18 24-93	Pan Seat
12	532 12 12-46	Bracket Mounting Switch
13	532 12 12-48	Bushing Snap Blk Nyl 50 Id

KEY NO.	PART NO.	DESCRIPTION
14	872 05 04-12	Bolt Rdhd Sqnk 1/4-20x1-1/2
15	532 13 43-00	Spacer Split 28x 96 Yel Zinc
16	532 12 12-50	Spring Cprsn 1 27 Blk Pnt
17	532 12 39-76	Nut Lock 1/4 Lge Flg Gr 5 Zinc
21	532 17 18-52	Bolt Shoulder 5/16-18 Unc
22	873 80 05-00	Nut Hex Lock W/Ins 5/16-18
23	871 11 08-14	Bolt Hex
24	819 17 19-12	Washer 17/32 X 1-3/16 X 12 Ga.
25	532 12 70-18	Bolt Shoulder 5/16-18 X 62
26	810 04 08-00	Washer Lock Hvy HLCL SPR 1/2

NOTE: All component dimensions given in U.S. inches.
1 inch = 25.4 mm

REPAIR PARTS

TRACTOR - MODEL NO. BM11M92T (BM11M92B), PRODUCT NO. 964 79 45-00
DECALS

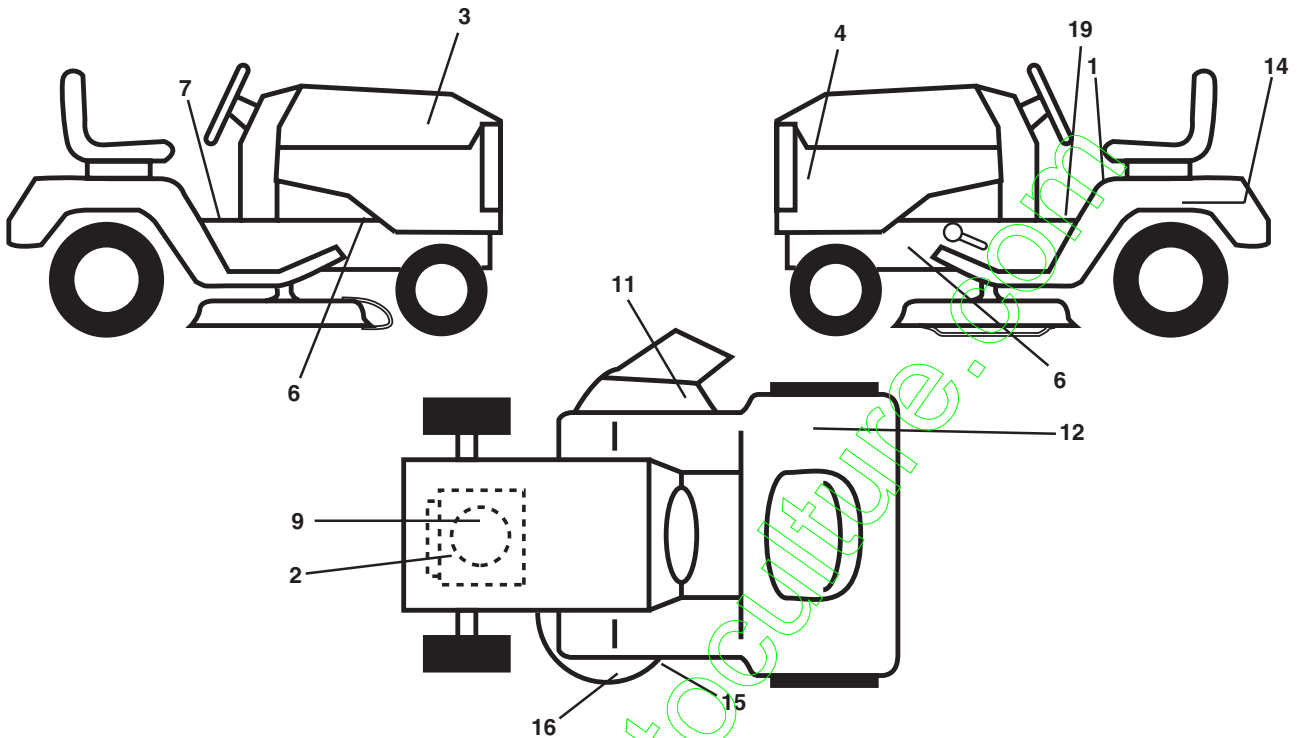

KEY NO.	PART NO.	DESCRIPTION
1	532 14 54-98	Decal Instruction Operation
2	532 18 69-06	Decal Warranty
3	532 18 97-43	Decal Hood RH
4	532 18 97-44	Decal Hood LH
6	532 15 97-36	Decal Chassis Hot Muffler
7	532 15 97-37	Decal Brake/Clutch Symbol LT
9	532 18 95-46	Decal HP Engine
11	532 18 21-66	Decal Mower Cut Finger Symbol
12	532 18 04-32	Decal 100 DE/CE
14	532 14 50-05	Decal Btry Dngr/PSN P/L Symbol
15	532 13 68-32	Decal V-Belt

KEY NO.	PART NO.	DESCRIPTION
16	532 13 49-99	Decal Deck
19	532 14 08-37	Decal Parking Brake
--	532 16 25-98	Decal Drawbar
--	532 13 83-11	Decal Handle Lift Height Adjust
--	532 18 98-70	Manual Parts
--	532 18 98-71	Manual Operator's (Euro.)
--	532 18 98-91	Manual Operator's (Port)
--	532 18 98-92	Manual Operator's (Polish)

WHEELS & TIRES

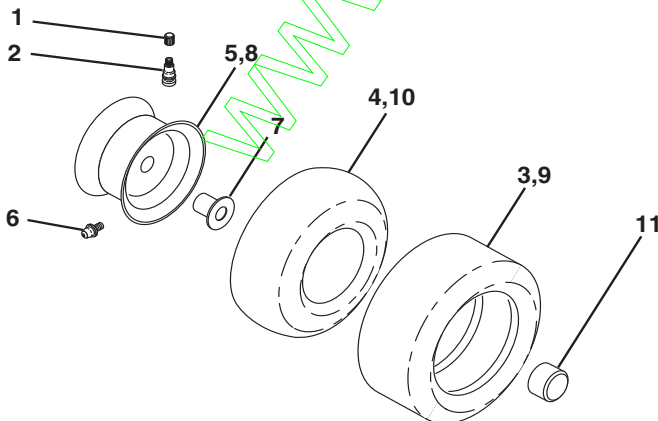

KEY NO.	PART NO.	DESCRIPTION
1	532 05 91-92	Cap Valve Tire
2	532 06 51-39	Stem Valve
3	532 12 41-57	Tire F Ts 15 X 6 0 - 6 Service
4	532 05 99-04	Tube Front (Service Item Only)
5	532 18 33-37	Rim Asm 6"front White Service
6	532 12 49-57	Fitting Grease (Front Wheel Only)
7	532 12 49-59	Bearing Flange (Front Wheel Only)
8	532 18 33-38	Rim Asm 8"rear White Service
9	532 12 39-69	Tire R Ts 18x8 5-8 C Service
10	532 12 49-26	Tube Rear (Service Item Only)
11	532 17 50-39	Cap Axle Blk 1 50 X 1 00
--	532 14 43-34	Sealant, Tire (10 oz. Tube)

NOTE: All component dimensions given in U.S. inches
1 inch = 25.4 mm

REPAIR PARTS

TRACTOR - MODEL NO. BM11M92T (BM11M92B), PRODUCT NO. 964 79 45-00 MOWER DECK

KEY NO.	PART NO.	DESCRIPTION	KEY NO.	PART NO.	DESCRIPTION
1	532 17 45-95	Mower Deck Assembly	54	532 17 85-15	Washer, Hardened
2	872 14 05-06	Bolt	55	532 13 38-40	Idler Arm Assembly
3	532 13 80-17	Bracket Assembly,Sway Bar	56	532 16 57-23	Spacer, Retainer
4	532 17 56-54	Bracket Sway Bar	67	532 10 69-32	Knob RD 3/8-16 Plstc Thd
5	532 12 46-70	Retainer Spring	68	532 18 02-13	Belt
6	532 17 80-24	Bar Sway Deck	69	532 12 47-88	Retainer Spring 1"
7	532 14 06-08	Keeper Belt	89	819 13 13-11	Washer 13/32 x 13/16 x 11 Ga.
8	532 85 08-57	Bolt, Hex 3/8-24 x 1.25 Gr. 8	107	532 13 35-02	Spacer, Retainer
9	810 03 06-00	Washer, Lock Hvy Hlcl 3/8	108	532 13 35-03	Stiffener, Idler Arm
10	532 14 02-96	Washer, Hardened	113	817 49 05-08	Screw Thdrol 5/16-18 x 1/2
11	532 13 84-96	Blade, Mower	122	532 17 45-05	Rod, Brake, LH
13	532 13 76-45	Shaft Assembly, Mandrel,	123	532 17 45-04	Rod, Brake, RH
14	532 12 87-74	Housing, Mandrel, Vented	146	532 16 58-91	Bolt Carriage Idler
15	532 11 04-85	Bearing, Ball, Mandrel	148	532 16 90-22	Spring Return Idler
16	532 17 44-93	Stripper, Mower Deck	149	532 16 58-98	Retainer Spring Yellow Zinc
19	532 13 28-27	Bolt, Shoulder	150	819 09 12-10	Washer 9/32 x 3/4 x 10 Ga.
21	873 68 05-00	Nut Crownlock 5/16-18	152	532 17 60-79	Cable Clutch
23	532 13 66-31	Bracket, Mower Deflector	158	817 72 04-08	Screw Hex Thd Cut 1/4-20 x 1/2
24	532 10 53-04	Cap, Sleeve	164	532 17 49-76	Idler Asm. Support
25	532 12 37-13	Spring, Torsion, Deflector	168	532 17 23-77	Bracket Deck Cable
26	532 11 04-52	Nut, Push	169	532 17 49-77	Bracket Asm Suspension
27	532 17 61-62	Shield, Deflector	170	532 17 23-59	Bracket Suspension RF
28	819 11 10-16	Washer 11/32 x 5/8 x 16 Ga.	171	532 16 52-37	Bracket Support Susp. Frt
29	532 12 19-80	Rod, Hinge	172	532 17 23-55	Bracket Suspension LF
30	532 17 39-84	Screw Thdrol	185	532 18 82-34	Head Asm Cable Clutch
31	532 18 76-90	Washer, Spacer	--	532 13 07-94	Mandrel Assembly (Includes Hous- ing, Shaft and Shaft Hardware Only - Pulley Not Included)
32	532 15 35-31	Pulley, Mandrel	--	532 18 13-76	Replacement Mower, Complete
33	532 17 83-42	Nut, Toplock, Flanged			
34	872 11 06-14	Bolt Rdhd 3/8-16 x 1-3/4			
36	532 13 14-94	Pulley, Idler, Flat			
40	873 68 06-00	Nut Crownlock 3/8-16			
45	532 12 47-88	Retainer, Spring			
53	532 13 08-40	Brake Assembly			

NOTE: All component dimensions given in U.S. inches
1 inch = 25.4 mm

REPAIR PARTS

TRACTOR - MODEL NO. BM11M92T (BM11M92B), PRODUCT NO. 964 79 45-00
MOWER LIFT

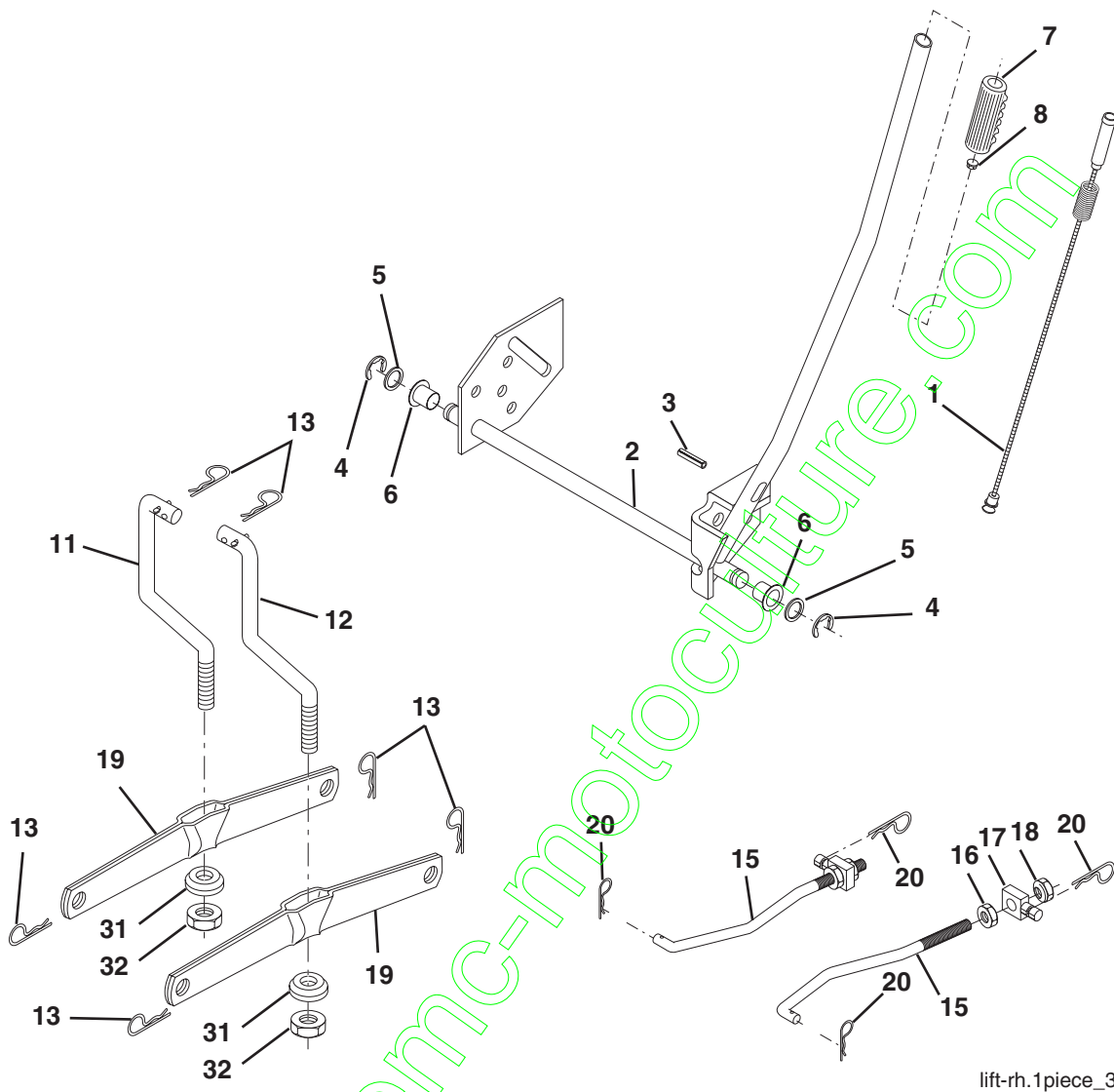

lift-rh.1piece_3

KEY NO.	PART NO.	DESCRIPTION
1	532 15 94-61	Wire Asm Inner/Spring W/plunger
2	532 15 94-76	Shaft Asm Lift
3	532 17 89-81	Pin Groove
4	812 00 00-02	E Ring #5133-62
5	819 21 16-21	Washer PLTD 21/32 X 1 X 21ga
6	532 12 01-83	Bearing Nylon Blk 629 Id
7	532 10 94-13	Grip Handle
8	532 12 45-26	Button Plunger Black
11	532 13 98-65	Link Lift LH
12	532 13 98-66	Link Lift RH
13	532 12 46-70	Retainer Spring

KEY NO.	PART NO.	DESCRIPTION
15	532 17 32-88	Link Front
16	873 35 08-00	Nut Jam Hex 1/2-13 Unc
17	532 17 56-89	Trunnion
18	873 80 08-00	Nut Lock W/wsh 1/2-13unc
19	532 13 98-68	Arm Suspension Rear
20	532 16 35-52	Spring, Retainer
31	532 16 98-65	Bearing Pvt. Lift
32	873 54 06-00	Nut Crownlock 3/8-24

NOTE: All component dimensions given in U.S. inches
1 inch = 25.4 mm



SERVICE POLICY WARRANTY



Issued January 1980
Revised January 1991

LIMITED WARRANTIES FOR NEW PEERLESS GEAR POWER TRAIN COMPONENTS

A. Products Warranted

Peerless Gear and Machine Division of Tecumseh Products Company ("Tecumseh"), subject to the limitations contained below, will, at its option, repair or replace, without charge for parts or labor only, any part of a new Power Train Component (which as used herein means and includes the transaxle, gear box, transmission, differential and right angle drives, and any part of the Power Train Component), EXCEPT any new Power Train Component incorporated in equipment used for commercial or rental purposes, which is found upon examination by any Tecumseh Authorized Service Outlet or by Tecumseh's factory in Grafton, Wisconsin, to be DEFECTIVE IN MATERIAL AND/OR WORKMANSHIP if received by Tecumseh or a Tecumseh Authorized Service Outlet for such examination within TWO YEARS from the date of sale to the original consumer purchaser of Peerless Series 820, 900, 910, 915, 920, 930 transaxles and Series 1100 angle drive and ONE YEAR for all other Peerless products. New Power Train Components incorporated in equipment used for commercial purposes are warranted in the same manner and to the same extent EXCEPT such Power Train Components are warranted for NINETY (90) DAYS ONLY, and must be received by Tecumseh or by a Tecumseh Authorized Service Outlet for such examination within 90 days from the date of sale to the original purchaser. New Power Train Components incorporated in equipment used for rental purposes are warranted in the same manner and to the same extent EXCEPT such Power Train Components are warranted for THIRTY (30) DAYS ONLY, and must be received by Tecumseh or a Tecumseh Authorized Service Outlet within 30 days from the date of sale to the original purchaser.

B. Products And Items Not Warranted

1. Alterations or Modifications of Power Train Components.
2. Accidents, Normal Maintenance, Failure to follow the Original Equipment Manufacturer's Manual.

This warranty covers only parts of new Power Train Components which are found upon examination to be defective in material or workmanship as delivered to the original purchaser. This warranty does not cover defects caused by depreciation or damage caused by normal wear, accidents, improper maintenance, improper use or abuse of the product, failure to follow the instructions contained in an Instruction Manual for the operation of the Power Train Component and parts. The cost of normal maintenance and replacement of service items which are not defective shall be paid for by the original purchaser.

C. Securing Warranty Service

Warranty service can be arranged for by contacting either a Tecumseh Authorized Service Outlet (any Tecumseh Registered Service Dealer, Tecumseh Authorized Service Distributor, or Tecumseh Central Warehouse Distributor) or by contacting Tecumseh, c/o Service Manager, Engine and Transmission Group Service Division, 900 North Street, Grafton, Wisconsin 53024. Warranty service can only be performed by a Tecumseh Authorized Service Outlet or by Tecumseh at its factory in Grafton, Wisconsin. At the time of requesting warranty service, evidence must be presented of the date of sale to the original purchaser. The purchaser shall pay any charges for making service calls and/or for transporting the product to and from the place where the inspection and/or warranty work is performed. The purchaser shall be responsible for any damage or loss incurred in connection with the transportation of Power Train Components and/or part(s) of the Power Train Components submitted for inspection and/or warranty work.

D. Limitation of Damages and Implied Warranties

The foregoing EXPRESSED WARRANTY IS IN LIEU OF ALL OTHER EXPRESS WARRANTIES. Neither Tecumseh nor any of its affiliates makes any warranties, representations or promises, written or oral, as to the quality of the Power Train Component or any of its parts, other than as set forth herein.

ANY IMPLIED WARRANTY OF MERCHANTABILITY OR FITNESS FOR A PARTICULAR PURPOSE, TO THE EXTENT THAT EITHER MAY APPLY TO ANY PART(S) OF POWER TRAIN COMPONENTS, SHALL BE LIMITED IN DURATION TO THE PERIODS OF THE EXPRESSED WARRANTIES DEFINED IN PARAGRAPH A HEREOF. IN NO EVENT WILL TECUMSEH BE LIABLE FOR ANY INCIDENTAL, CONSEQUENTIAL OR SPECIAL DAMAGES AND/OR EXPENSES. Some states do not allow limitations on how long an implied warranty lasts or the exclusion or limitation of incidental or consequential damages, so the above limitation(s) or exclusion(s) may not apply to you. This warranty gives you specific legal rights and you may also have other legal rights which vary from state to state.

E. No Dealer Warranty

Tecumseh neither assumes nor authorizes any other person, natural or corporate, to assume for Tecumseh any other obligations or liabilities in connection with or with respect to any part(s) of a Power Train Component. The seller or dealer of part(s) of a Power Train Component has no authority, whatsoever, to make any representations or promises on behalf of Tecumseh or to modify the terms or limitations of Tecumseh's warranty in any way.

www.emc-motoculture.com

 **Electrolux**