

REPAIR PARTS MANUAL
MODEL NO. BM125B97 (96011024203)
Lawn Tractor

BESTGREEN

HOW TO USE THIS MANUAL

This manual is designed to provide the customer with a means to identify the parts on his/her tractor when ordering repair parts. The illustrations may or may not represent the actual assemblies; therefore, it is not recommended to use this manual as a guide to assemble or disassemble the tractor. Some hardware and parts are drawn larger in order to more readily identify them.

Each tractor has its own model number.

The model number for your tractor can be found on the fender under the seat.

When ordering parts, always give the following information:

- Product - “**Lawn Tractor**”
- Model Number - **BM125B97 (96011024203)**
- Part Number
- Part Description

TABLE OF CONTENTS

SCHEMATIC	3
ELECTRICAL.....	4-5
CHASSIS AND ENCLOSURES.....	6-7
DRIVE.....	8-9
STEERING WHEEL	10-11
ENGINE.....	12-13
SEAT	14
DECALS.....	15
MOWER DECK	16-17
MOWER LIFT.....	18

TRACTOR - MODEL NO. BM125B97 (96011024203), PRODUCT NO. 960 11 02-42 SCHEMATIC

SCH01

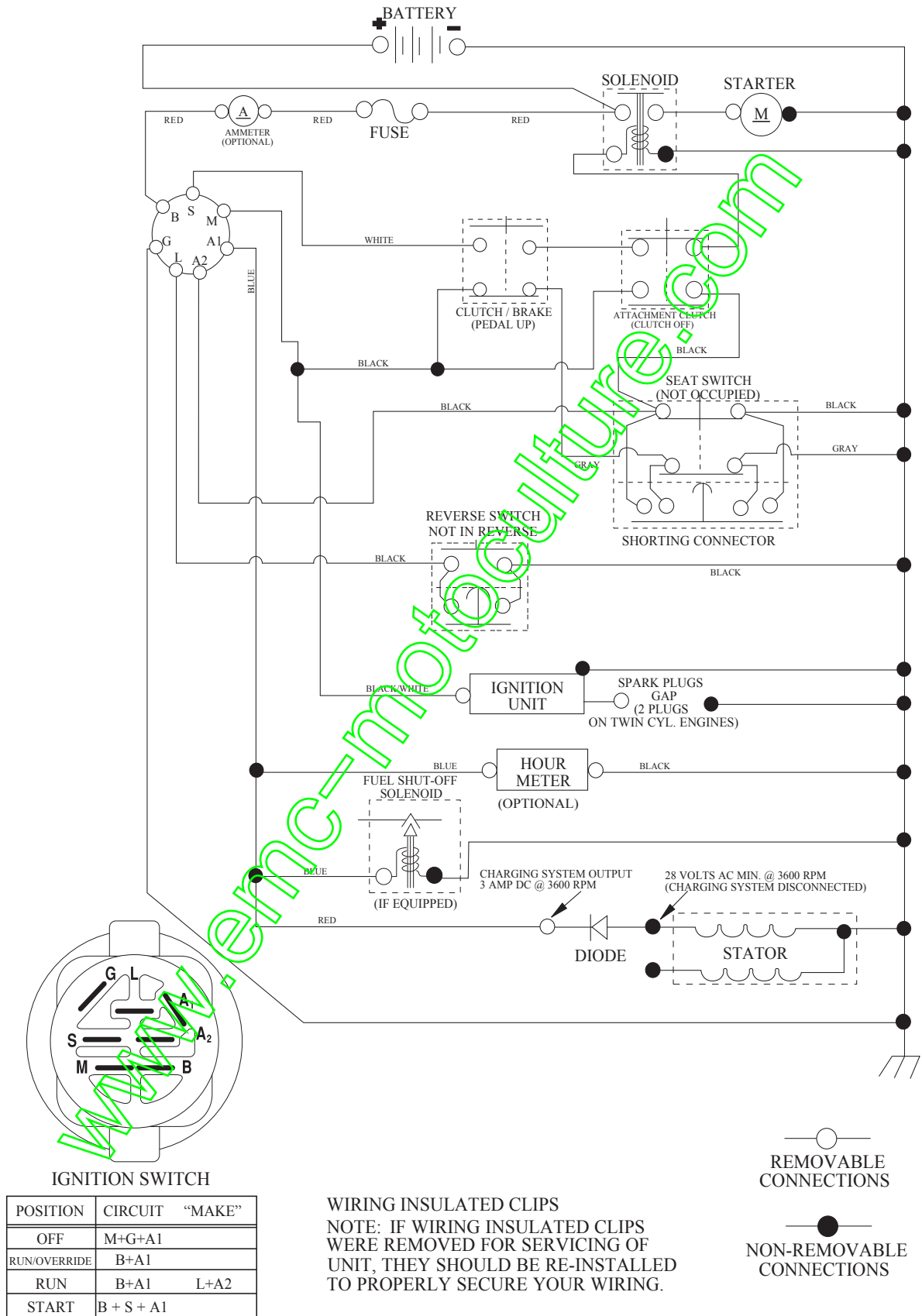

REPAIR PARTS

TRACTOR - MODEL NO. BM125B97 (96011024203), PRODUCT NO. 960 11 02-42
ELECTRICAL

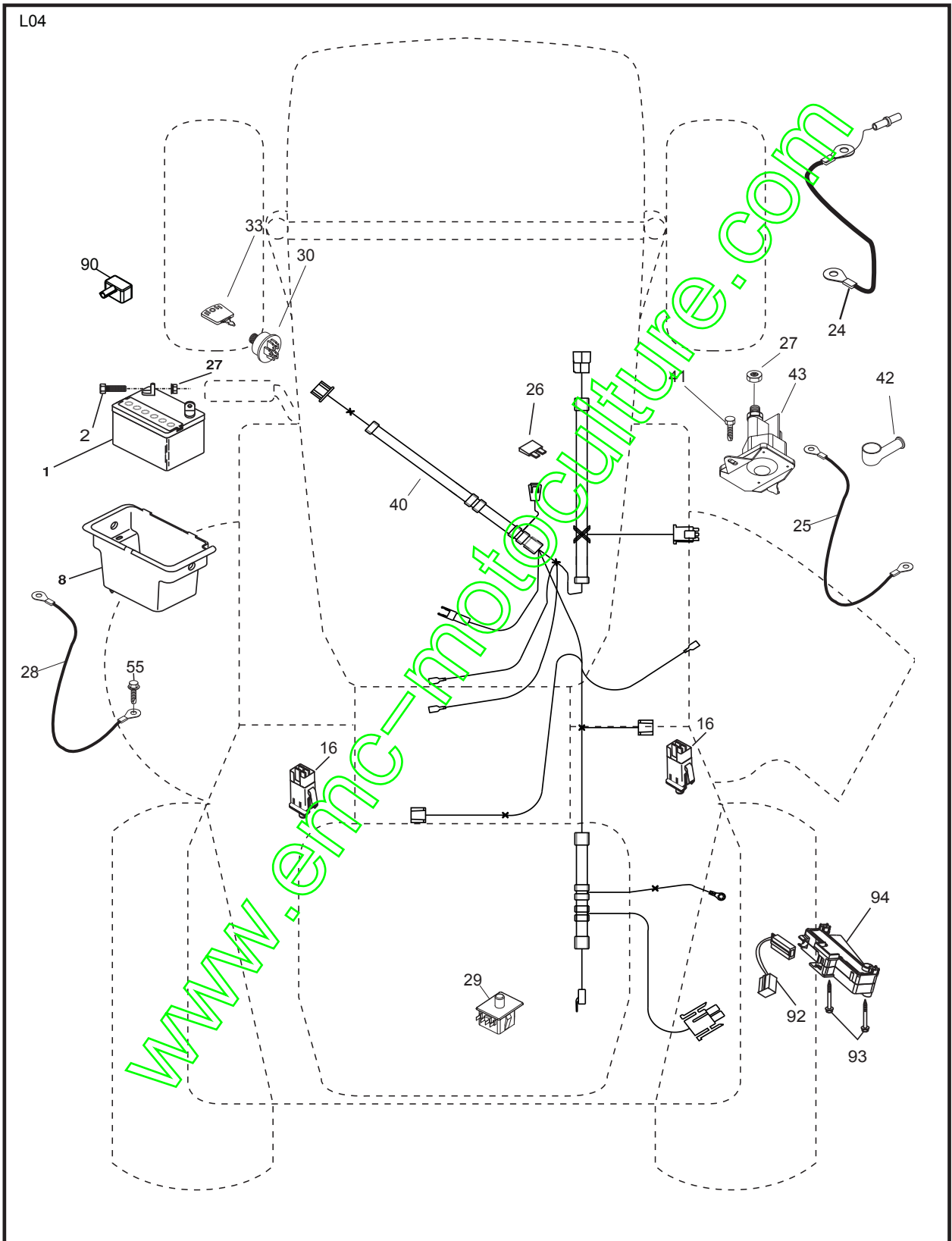

REPAIR PARTS

TRACTOR - MODEL NO. BM125B97 (96011024203), PRODUCT NO. 960 11 02-42
ELECTRICAL

KEY NO.	PART NO.	DESCRIPTION
1	532 16 34-65	Battery 12 Volt 25 AMP
2	874 76 04-12	Bolt Hex Hd 1/4-20 unc x 3/4
8	532 17 66-89	Box Battery
16	532 17 61-38	Switch Interlock Push-In
24	532 12 47-80	Cable Battery 6 Ga 11" red
25	532 14 61-47	Cable Battery 6 Ga 44" red w/16 wire
26	532 17 51-58	Fuse 20 AMP
27	873 51 04-00	Nut Keps Hex 1/4-20 unc
28	532 12 47-73	Cable Ground 6 Ga 12" black
29	532 19 27-49	Switch Seat
30	532 19 33-50	Switch Ign
33	532 41 19-35	Key/Chain
40	532 19 74-28	Harness Ign
41	871 11 04-08	Bolt Blk Fin Hex 1/4 - 20 x 1/2
42	532 13 15-63	Cover Terminal Red
43	532 19 25-07	Solenoid
55	817 00 06-12	Screw THDROL 3/8-16 x 3/4
90	532 18 04-49	Cover Terminal Battery
92	532 19 66-15	Harness Pigtail Console ROS
93	532 19 25-40	Screw Plastite 10-14 x 2.0
94	532 19 18-34	Module Reverse ROS

NOTE: All component dimensions given in U.S. inches.
1 inch = 25.4 mm.

REPAIR PARTS

TRACTOR - MODEL NO. BM125B97 (96011024203), PRODUCT NO. 960 11 02-42
CHASSIS AND ENCLOSURES

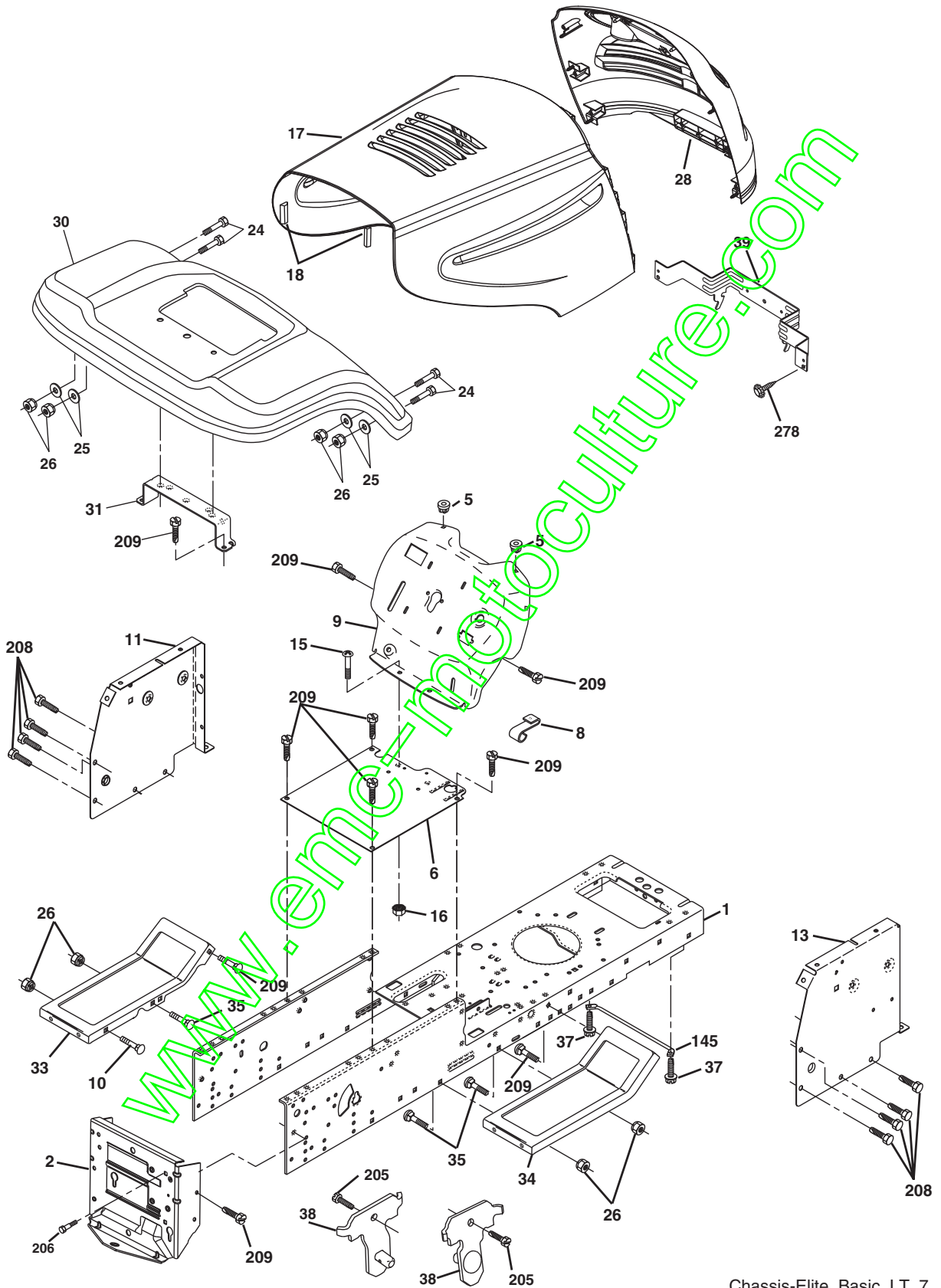

Chassis-Elite_Basic_LT_7

REPAIR PARTS

TRACTOR - MODEL NO. BM125B97 (96011024203), PRODUCT NO. 960 11 02-42
CHASSIS AND ENCLOSURES

KEY NO.	PART NO.	DESCRIPTION
1	532 17 46-20	Chassis Stamping
2	532 17 65-54	Drawbar
5	532 15 52-72	Bumper Hood/Dash
6	532 18 44-19	Saddle, Flat
8	532 15 51-38	Clip Retainer
9	532 19 46-88	Dash P/L
10	872 14 06-08	Bolt Carriage 3/8-16 x 1
11	532 17 49-96	Panel Dash LH
13	532 18 69-52	Panel Dash RH
15	874 18 05-12	Screw Mach. TRHD 5/16-18 unc x 3/4
16	873 51 05-00	Nut Keps 5/16-18 unc
17	532 19 24-37	Hood
18	532 18 49-21	Bumper Hood
24	874 78 06-16	Bolt Fin Hex 3/8-16 unc x 1 Gr. 5
25	819 13 13-12	Washer 13/32 X 13/16 x 12 Ga.
26	873 80 06-00	Nut Lock Hex W/Ins 3/8-16 unc
28	532 18 67-18	Grille
30	532 40 30-26	Fender
31	532 13 66-19	Bracket Support Fender
33	532 18 64-57	Footrest LH
34	532 18 64-58	Footrest RH
35	872 11 06-06	Bolt RDHD SHT SQNK 3/8-16 x 3/4
37	817 49 05-08	Screw Thdrol 6/16-18 x 1/2 TYT
38	532 17 57-10	Bracket, Asm. Pivot, Mower Rear
39	532 40 78-07	Bracket Pivot
145	532 40 91-67	Rod Pivot Chassis/Hood
205	817 49 06-08	Screw Thdrol 3/8-16 x 1/2
206	532 17 01-65	Bolt Shoulder 5/16-18 TT
208	817 67 06-08	Screw Thdrol 3/8-16 x 1/2
209	817 00 06-12	Screw Thdr 3/8-16 x 3/4
278	532 41 63-58	Screw #10 x 0.750
--	532 00 54-79	Plug Button
--	532 19 39-35	Plug Btn.

NOTE: All component dimensions given in U.S. inches
1 inch = 25.4 mm

REPAIR PARTS

TRACTOR - MODEL NO. BM125B97 (96011024203), PRODUCT NO. 960 11 02-42
DRIVE

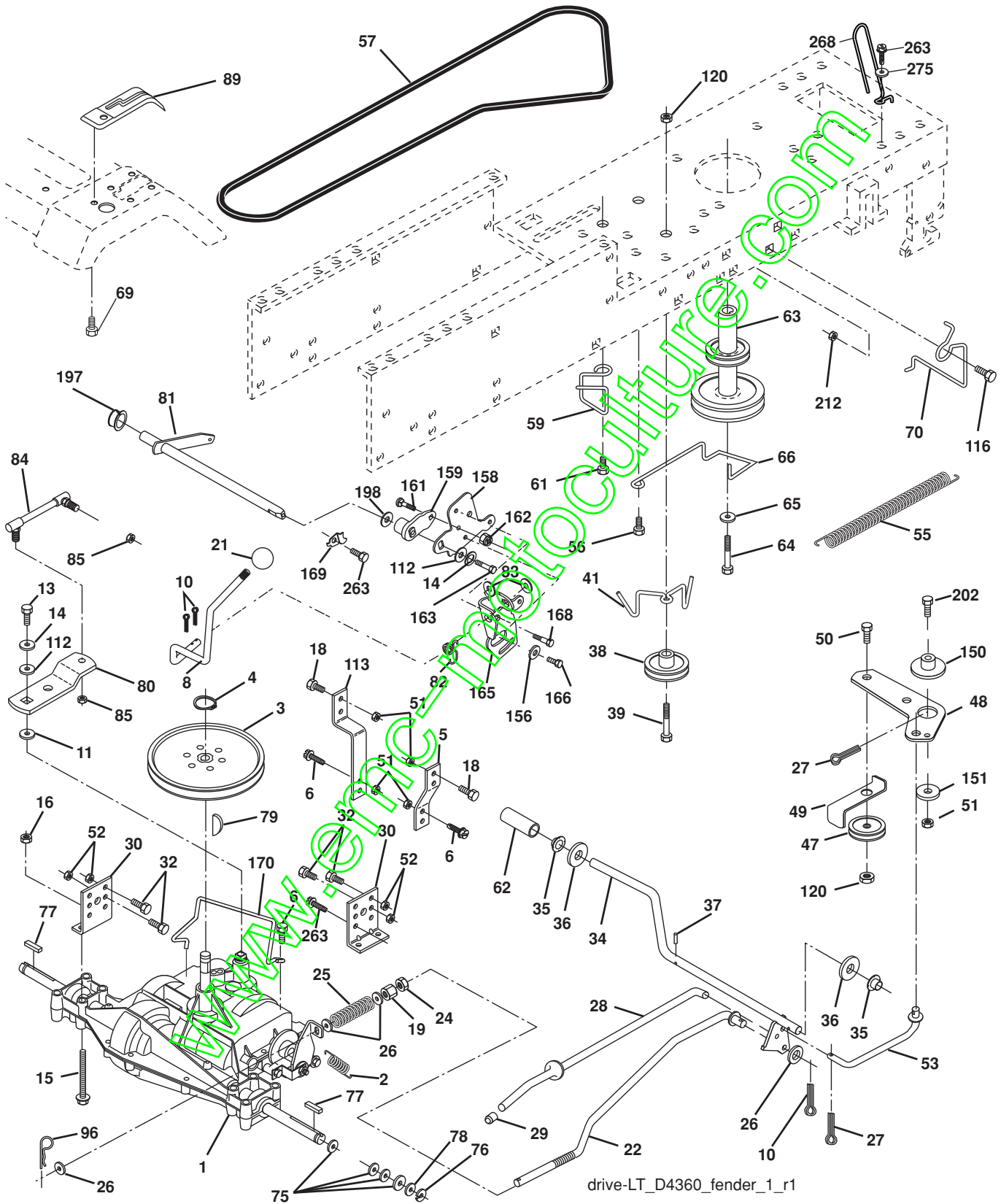

drive-LT_D4360_fender_1_r1

REPAIR PARTS

**TRACTOR - MODEL NO. BM125B97 (96011024203), PRODUCT NO. 960 11 02-42
DRIVE**

KEY NO.	PART NO.	DESCRIPTION	KEY NO.	PART NO.	DESCRIPTION
1	-----	Transaxle Peerless 205-544C	65	810 04 07-00	Washer Lock Hvy Hlcl Spr 7/16
2	532 14 66-82	Spring Return Brake T/a Zinc	66	532 15 47-78	Keeper Belt Engine Foolproof
3	532 12 36-66	Pulley Transaxle 18" Tires	69	532 14 24-32	Screw Hex 1/4-1/2 unc
4	812 00 00-28	Ring Retainer # 5100-62	70	532 13 46-83	Guide Belt Mower Drive RH
5	532 12 15-20	Strap Torque 30 Degrees	74	532 13 70-57	Spacer Axle
6	817 06 05-12	Screw Thdrol 5/16-18 x 3/4	75	532 12 17-49	Washer 25/32 x 1 1/4 x 16 Ga.
8	532 19 27-06	Rod Shift Fender Adjust Lt	76	812 00 00-01	E-ring #5133-75
10	876 02 04-16	Pin Cotter 1/8 x 1 Cad	77	532 12 35-83	Key Square 2 0 x 1845/ 1865
11	532 10 57-01	Washer Plate Shf 388 Sq Hole	78	532 12 17-48	Washer 25/32 x 1-5/8 x 16 Ga.
13	874 55 04-12	Bolt 1/4-28 unf Gr. 8 W/Patch	79	532 12 50-96	Key Woodruff #9 3/16 x 3/4
14	810 04 04-00	Washer Lock Hvy Helical	80	532 13 14-86	Arm Shift
15	874 49 05-44	Bolt Hex 5/16-18 Gr. 5	81	532 16 55-94	Shaft Asm Cross 18"t
16	873 80 05-00	Nut Lock Hex w/Ins 5/16-18	82	532 16 57-11	Spring Torsion T/a
18	874 78 06-16	Bolt, Fin Hex 3/8-16 unc x 1 Gr. 5	83	819 17 12-16	Washer 17/32 x 3/4 x 16 Ga.
19	873 80 06-00	Nut Lock 3/8-16 unc	84	532 16 62-28	Link Transaxle
21	532 10 69-33	Knob	85	532 15 03-60	Nut Lock Center 1/4 - 28 FNTHD
22	532 13 08-04	Rod Brake Blk	89	532 19 58-61	Console Shift STLT
24	873 35 06-00	Nut Hex Jam 3/8-16 unc	96	532 12 47-88	Retainer Spring 1"
25	532 10 68-88	Spring Rod Brake 2 00 Zinc	112	819 09 12-10	Washer 9/32 x 3/4 x 10 Ga.
26	819 13 13-16	Washer 13/32 x 13/16 x 16 Ga.	113	532 12 72-85	Strap Torque LT
27	876 02 04-12	Pin Cotter 1/8 x 3/4 Cad	116	872 14 06-08	Bolt Rdhd Sq Neck 3/8-16 x 1.0
28	532 17 57-65	Rod Brake Parking LT/YT	120	873 90 06-00	Nut Lock Flg. 3/8-16 unc
29	532 07 16-73	Cap Brake Parking Black	150	532 17 54-56	Spacer
30	532 17 49-73	Bracket Mtg Transaxle	151	819 13 32-10	Washer 13/32 x 2 x 10 Ga.
32	874 76 05-12	Bolt Hex Hd 5/16-18 unc x 3/4	156	532 16 60-02	Washer Srrted 5/16 ID x 1.125
34	532 17 55-78	Shaft Asm Pedal Foot	158	532 16 55-89	Bracket Shift Mount
35	532 12 01-83	Bearing Nylon Blk 629 Id	159	532 18 39-00	Hub Shift
36	819 21 16-16	Washer 21/32 x 1 x 16 Ga.	161	872 14 04-06	Bolt Rdhd Sqnk 1/4-20 x 3/4 Gr. 5
37	532 12 49-63	Pin Roll 3/16 x 1"	162	873 68 04-00	Nut Crownlock 1/4-20 unc
38	532 17 91-14	Pulley Idler Composite	163	874 78 04-16	Bolt Hex Fin 1/4-20 unc x 1 Gr. 5
39	872 11 06-22	Bolt Fin Hex 3/8-16 unc x 2-3/4 Gr. 5	165	532 16 56-23	Bracket Pivot Lever
41	532 17 55-56	Keeper Belt Idler Flat	166	817 49 05-10	Screw 5/16-18 x 5/8
47	532 12 77-83	Pulley Idler V Groove Plastic	168	532 16 54-92	Bolt Shoulder 5/16-18 x .561
48	532 15 44-07	Bellcrank Clutch Grnd Driv	169	532 16 55-81	Plate Fastening Lt
49	532 12 32-05	Retainer Belt Style Spring	170	532 18 74-14	Keeper, Belt T/A
50	872 11 06-12	Bolt 3/8-16 x 1-1/2 Gr. 5	197	532 16 96-13	Nyliner Snap-In
51	873 68 06-00	Nut Crownlock 3/8-16 unc	198	532 16 98-45	Washer Nyl
52	873 68 05-00	Nut Crownlock 5/16-18 unc	202	872 11 06-14	Bolt Carr. SH 3/8-16 x 1-3/4 Gr. 5
53	532 19 96-52	Link Clutch	212	532 14 52-12	Nut, Hex Flange Lock
55	532 10 57-09	Spring Return Clutch 6 75	263	817 00 06-12	Screw 3/8-16 x 3/4
56	817 06 06-20	Screw 3/8-16 x 3/4	268	532 18 24-02	Guard Muffler
57	532 13 82-55	V-Belt Ground Drive	275	819 13 16-14	Washer 13/32 x 1 x 14 Ga.
59	532 16 96-91	Keeper Belt Span Ctr			
61	817 12 06-14	Screw 3/8-16 x .875			
62	532 12 48-72	Cover Pedal Round			
63	532 17 54-10	Engine Pulley			
64	532 17 39-37	Bolt Hex			

NOTE: All component dimensions given in U.S. inches
1 inch = 25.4 mm.

REPAIR PARTS

TRACTOR - MODEL NO. BM125B97 (96011024203), PRODUCT NO. 960 11 02-42
STEERING ASSEMBLY

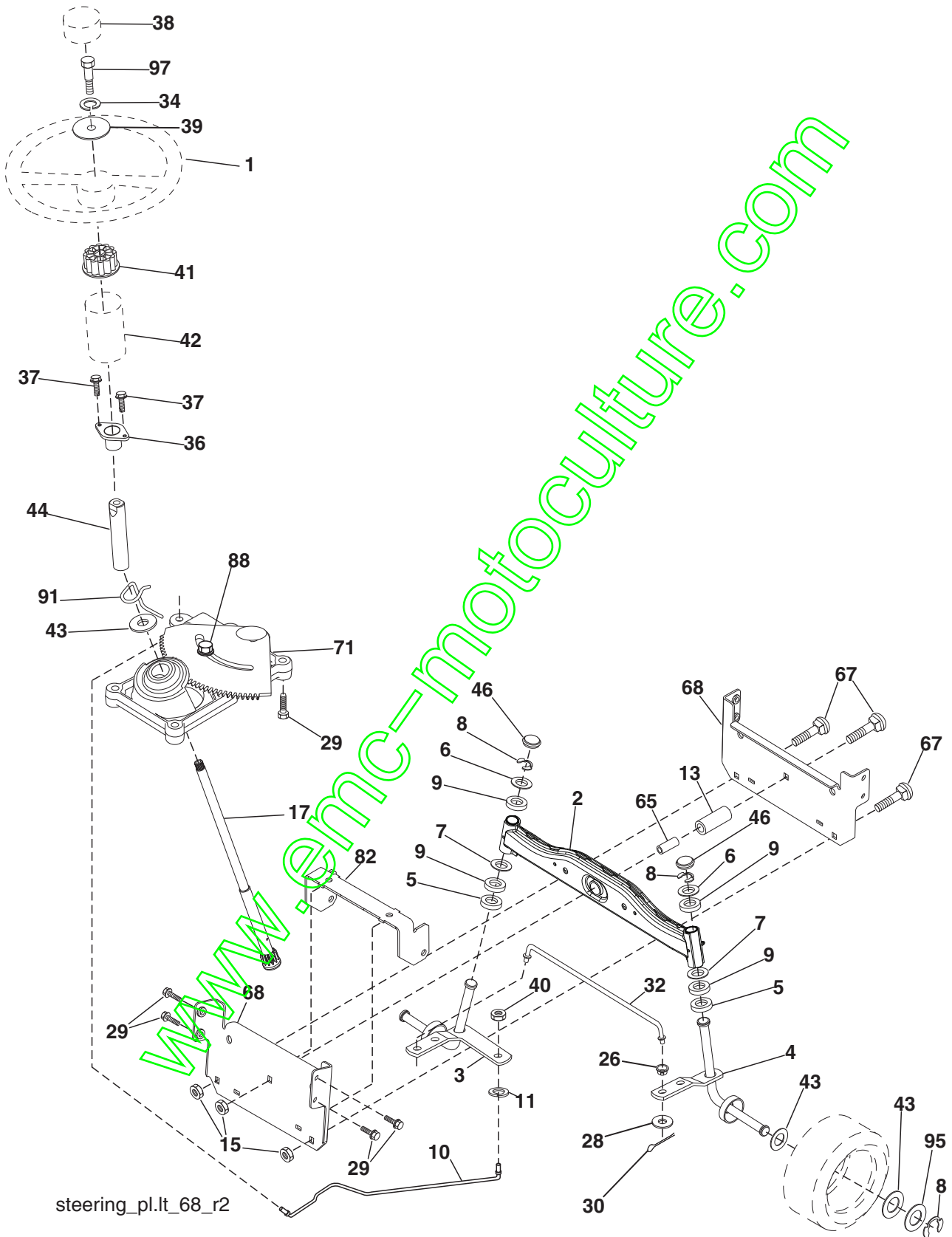

REPAIR PARTS

TRACTOR - MODEL NO. BM125B97 (96011024203), PRODUCT NO. 960 11 02-42
STEERING ASSEMBLY

KEY NO.	PART NO.	DESCRIPTION
1	532 18 67-80	Wheel Steering
2	532 41 81-68	Axle Asm
3	532 16 98-40	Spindle Asm LH
4	532 16 98-39	Spindle Asm RH
5	532 12 49-31	Bearing Race Thrust Harden
6	532 12 17-48	Washer 25/32 x 1-5/8 x 16 Ga.
7	819 27 20-16	Washer 27/32 x 1-1/4 x 16 Ga.
8	812 00 00-29	Ring Clip #t5304-75
9	532 12 49-37	Bearing Col Strg Blk
10	532 17 51-21	Link Drag
11	810 04 06-00	Washer Lock Hvy Hlcl Spr 3/8
13	532 13 65-18	Spacer Brg Axle Front
15	532 14 52-12	Nut Hex Flange Lock
17	532 19 07-53	Shaft Asm Strg
26	532 12 68-47	Bushing Link Drag Blk LR
28	819 13 14-16	Washer 13/32 x 7/8 x 16 Ga.
29	817 00 06-12	Screw 3/8-16 x 3/4
30	876 02 04-12	Pin Cotter 1/8 x 3/4 Cad
32	532 19 27-57	Rod Tie Wire Form
34	810 04 05-00	Washer Lock Hvy HLCL Spr. 5/16
36	532 15 50-99	Bushing Strg
37	532 15 29-27	Screw
38	532 19 29-16	Insert Cap Strg Wh
39	819 11 38-12	Washer 11/32- ID x 2-3/8 OD 12 Ga.
40	873 54 06-00	Nut Crownlock 3/8-24
41	532 18 67-37	Adaptor Wheel Strg
42	532 16 96-33	Boot Steering Shaft
43	532 12 17-49	Washer 25/32 x 1-1/4 x 16 Ga.
44	532 19 07-52	Extension Steering Shaft
46	532 12 12-32	Cap Spindle Fr Top Blk
65	532 41 47-36	Spacer Brace Axle
67	872 11 06-18	Bolt, Rdhd Sqnk 3/8-16 x 2-1/4
68	532 16 98-27	Axle, Brace
71	532 17 51-46	Steering Asm.
82	532 19 99-78	Bracket Susp Chassis Front
86	532 17 51-18	Bolt Shoulder 7/16-20
91	532 17 55-53	Clip Steering
95	532 18 89-67	Washer Hardened
97	874 78 05-64	Bolt 5/16-18 unc x 4" L Gr. 5

NOTE: All component dimensions given in U.S. inches.
1 inch = 25.4 mm.

REPAIR PARTS

TRACTOR - MODEL NO. BM125B97 (96011024203), PRODUCT NO. 960 11 02-42
ENGINE

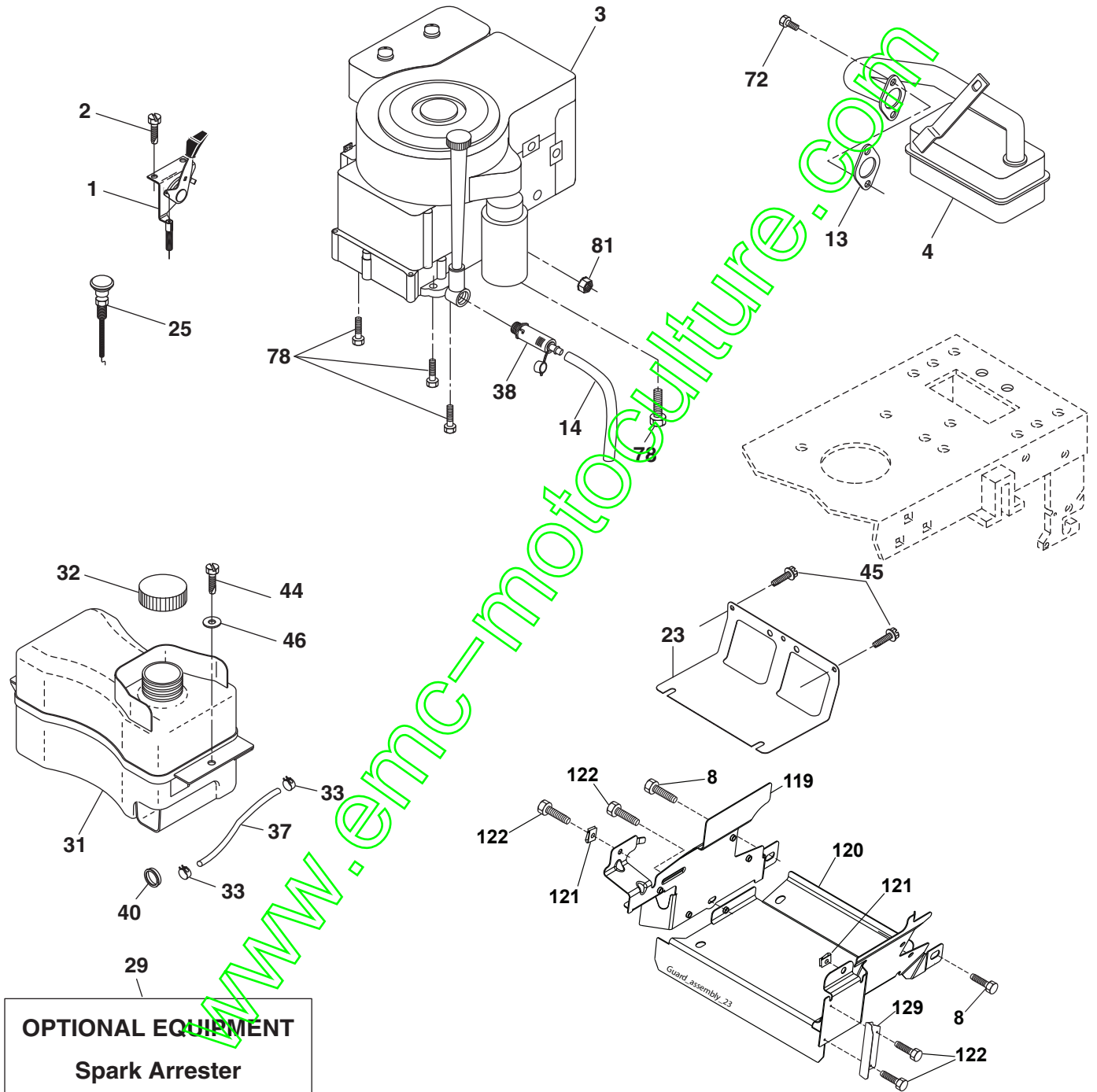

OPTIONAL EQUIPMENT
Spark Arrester

engine-sttt_bs_2

REPAIR PARTS

TRACTOR - MODEL NO. BM125B97 (96011024203), PRODUCT NO. 960 11 02-42
ENGINE

KEY NO.	PART NO.	DESCRIPTION
1	532 17 05-51	Control Throttle
2	817 72 04-08	Screw Hex Thd Cut 1/4-20 x 1/2
3	-----	Engine B&S Model No. 219807-0388-B1
4	532 17 97-58	Muffler LT B&S
8	532 17 18-77	Bolt 5/16-18 unc x 3/4 w/Semis
13	532 16 52-91	Gasket
14	532 14 84-56	Tube Drain Oil Easy
23	532 16 98-37	Shield Brn/Dbr Guard
25	532 19 06-95	Control Choke
29	532 13 71-80	Kit Spark Arrester (Flat Scrn)
31	532 40 75-16	Tank Fuel Front
32	532 19 77-25	Cap Asm Fuel
33	532 12 34-87	Clamp Hose Black
37	532 13 70-40	Line Fuel 20"
38	532 18 16-54	Plug Drain Oil Easy
40	532 12 40-28	Bushing Snap Nyl Blk Fuel Line
44	817 67 04-12	Screw Hexwsh Thdrol 1/4-20 x 3/4
45	817 00 06-12	Screw Hex Wsh Thdrol 3/8-16 x 3/4
46	819 09 14-16	Washer 3/32 x 7/8 x 16 Ga.
72	532 19 23-34	Screw Socket HD 5/16-18 x 3/4
78	817 06 06-20	Screw 3/8-16 x 1-1/4
81	873 51 04-00	Nut 1/4-20
119	532 19 79-49	Guard Asm Eng. LH
120	532 19 79-48	Guard Asm Eng. RH
121	532 19 66-88	Clips Threaded
122	532 13 77-29	Screw TH Roll 1/4-20 x 5/8
129	532 40 03-28	Guard Pulley Eng. Adapter

NOTE: All component dimensions given in U.S. inches
1 inch = 25.4 mm

Engine Power Rating Information

The gross power rating for individual gas engine models is labeled in accordance with SAE (Society of Automotive Engineers) code J11940 (Small Engine Power & Torque Rating Procedure), and rating performance has been obtained and corrected in accordance with SAE J1995 (Revision 2002-5). Actual gross engine power will be lower and is affected by, among other things, ambient operating conditions and engine-to-engine variability. Given both the wide array of products on which engines are placed and the variety of environmental issues applicable to operating the equipment, the gas engine will not develop the rated gross power when used in a given piece of power equipment (actual "on-site" or net horsepower). This difference is due to a variety of factors including, but not limited to, accessories (air cleaner, exhaust, charging, cooling, carburetor, fuel pump, etc.), application limitations, ambient operating conditions (temperature, humidity, altitude), and engine-to-engine variability. Due to manufacturing and capacity limitations, Briggs & Stratton may substitute an engine of higher rated power for this Series engine.

REPAIR PARTS

TRACTOR - MODEL NO. BM125B97 (96011024203), PRODUCT NO. 960 11 02-42
SEAT ASSEMBLY

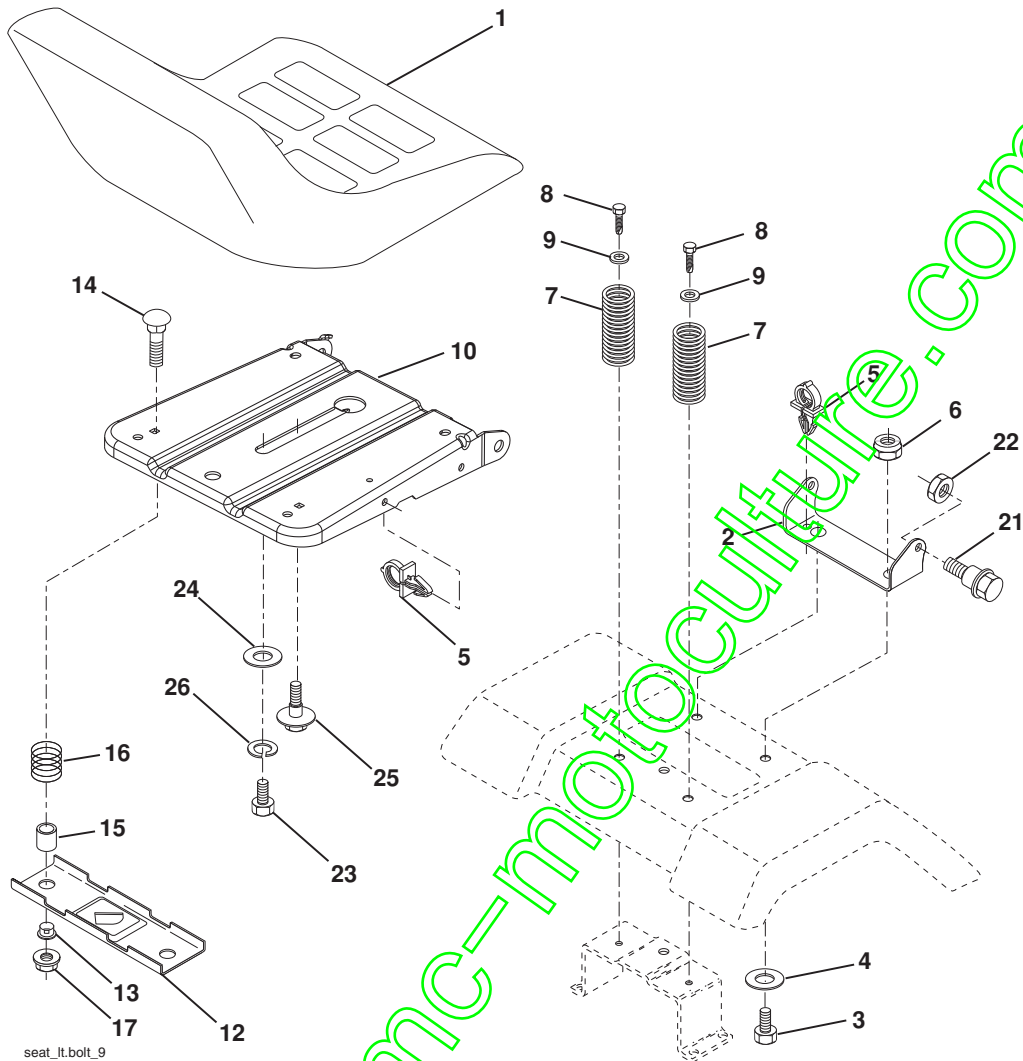

KEY NO.	PART NO.	DESCRIPTION
1	532 40 10-42	Seat
2	532 14 05-51	Bracket Pivot Seat 8 720
3	871 11 06-16	Bolt Fin Hex 3/8-16 unc x 1
4	819 13 16-10	Washer 13/32 x 1 x 10 Ga.
5	532 14 50-06	Clip Push-In
6	873 80 06-00	Nut Hex w/Ins. 3/8-16 unc
7	532 12 41-81	Spring Seat Cprsn 2 250 Blk Zi
8	817 00 06-16	Screw 3/8-16 x 1-1/2
9	819 13 16-14	Washer 13/32 x 1 x 14 Ga.
10	532 19 55-30	Pan Seat
12	532 17 46-48	Bracket Mounting Switch
13	532 12 12-48	Bushing Snap Blk Nyl 50 Id
14	872 05 04-12	Bolt Rdhd Sqnk 1/4-20 x 1-1/2

KEY NO.	PART NO.	DESCRIPTION
15	532 13 43-00	Spacer Split 28 x 96 Yel Zinc
16	532 12 12-50	Spring Cprsn 1 27 Blk Pnt
17	532 12 39-76	Nut Lock 1/4 Lge Flg Gr. 5 Zinc
21	532 17 18-52	Bolt Shoulder 5/16-18 unc
22	873 80 05-00	Nut Hex Lock W/Ins 5/16-18
23	871 11 08-14	Bolt Hex
24	819 17 19-12	Washer 17/32 x 1-3/16 x 12 Ga.
25	532 12 70-18	Bolt Shoulder 5/16-18 x 62
26	810 04 08-00	Washer Lock Hvy HLCL SPR 1/2

NOTE: All component dimensions given in U.S. inches.
1 inch = 25.4 mm

REPAIR PARTS

TRACTOR - MODEL NO. BM125B97 (96011024203), PRODUCT NO. 960 11 02-42
DECALS

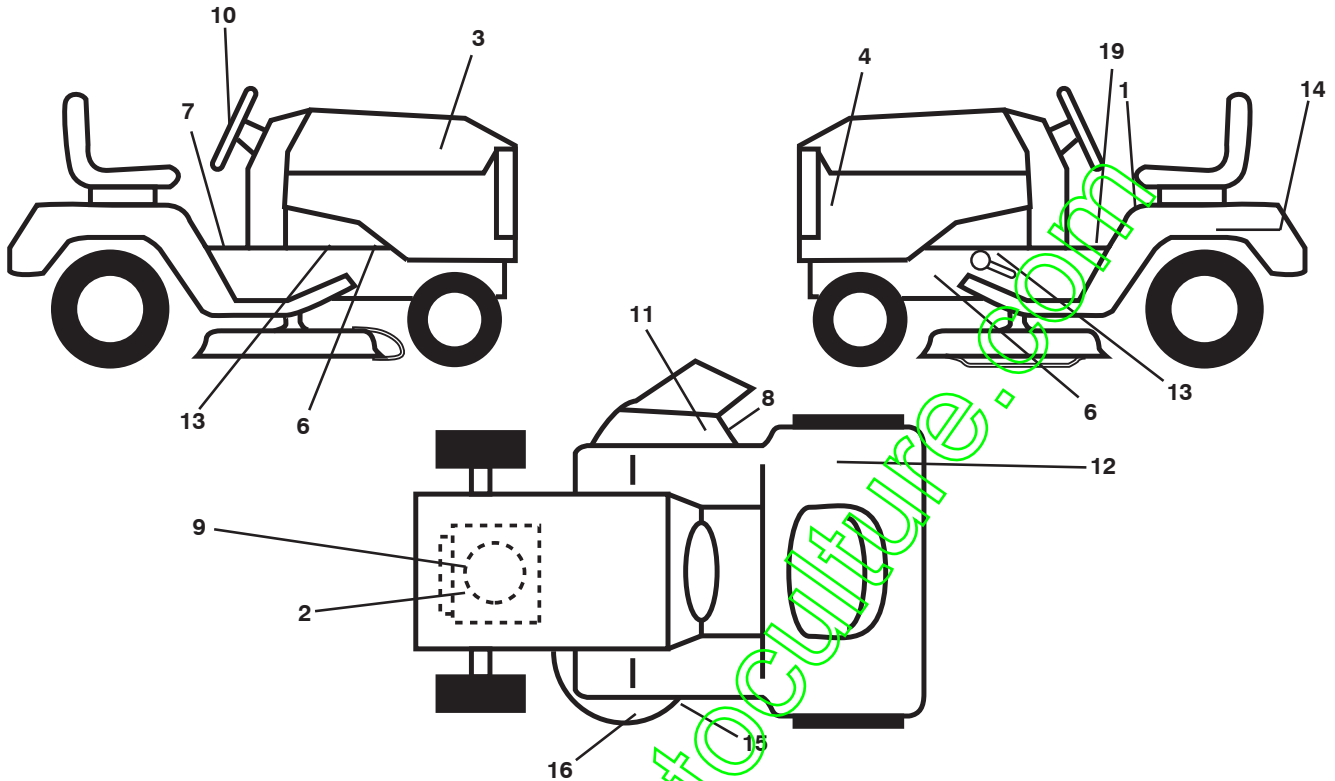

KEY NO.	PART NO.	DESCRIPTION
1	532 40 03-89	Decal Warning Symbols CE
2	532 19 68-41	Decal Warning Eng Syms.
3	532 40 84-79	Decal Hood RH
4	532 40 84-80	Decal Hood LH
6	532 15 97-36	Decal Chassis Hot Muffler
7	532 15 97-37	Decal Brake/Clutch Symbol LT
8	532 19 63-57	Decal Deflect Warning Cutfinger
9	532 40 88-13	Decal Engine HP
10	532 40 23-03	Decal WHL STRG
11	532 18 21-66	Decal Mower Cut Finger Symbol

KEY NO.	PART NO.	DESCRIPTION
12	532 18 04-32	Decal 100 DE/CE
13	532 19 68-42	Decal SDL SHF/CRD Sym Cutfinger
14	532 14 50-05	Decal Btry Dngr/PSN P/L Symbol
15	532 19 43-02	Decal V-Belt
16	532 13 49-99	Decal Deck
19	532 14 08-37	Decal Parking Brake
--	532 16 25-98	Decal Drawbar
--	532 13 83-11	Decal Handle Lift Height Adjust
--	532 40 82-67	Manual Operator's (Euro.)
--	532 41 90-59	Manual Parts

WHEELS & TIRES

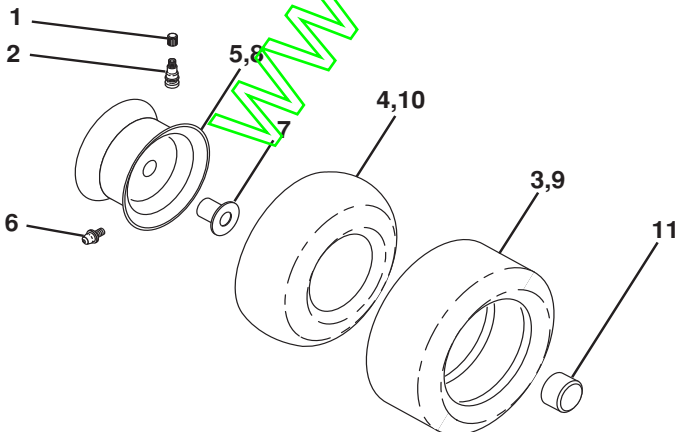

KEY NO.	PART NO.	DESCRIPTION
1	532 05 91-92	Cap Valve Tire
2	532 06 51-39	Stem Valve
3	532 12 41-57	Tire F Ts 15 x 6 0 - 6 Service
4	532 05 99-04	Tube Front (Service Item Only)
5	532 13 83-36	Rim Asm 6" Front Service
6	532 12 49-57	Fitting Grease (Front Wheel Only)
7	532 12 49-59	Bearing Flange (Front Wheel Only)
8	532 13 83-37	Rim Asm 8" Rear Service
9	532 12 39-69	Tire R Ts 18 x 8 5-8 C Service
10	532 12 49-26	Tube Rear (Service Item Only)
11	532 17 50-39	Cap Axle Blk 1 50 x 1 00
--	532 14 43-34	Sealant, Tire (10 oz. Tube)

NOTE: All component dimensions given in U.S. inches
1 inch = 25.4 mm

REPAIR PARTS

TRACTOR - MODEL NO. BM125B97 (96011024203), PRODUCT NO. 960 11 02-42 MOWER DECK

KEY NO.	PART NO.	DESCRIPTION	KEY NO.	PART NO.	DESCRIPTION
1	532 19 25-56	Mower Housing Assembly	92	873 80 06-00	Nut Lock Hex W/Ins. 3/8-16 unc
2	872 14 05-06	Bolt Carriage 5/16-18 x 3/4	107	532 13 35-02	Spacer Retainer
3	532 13 80-17	Bracket Asm Fr. Sway Bar	108	532 13 35-03	Stiffener, Idler Arm
4	532 19 25-68	Bracket Deck Sway Bar 38"/42"	122	532 41 01-89	Link, Brake LH
5	532 12 46-70	Retainer Spring	123	532 41 01-90	Link, Brake RH
6	532 17 80-24	Bar Sway Deck	144	532 19 34-14	Keeper Belt Idler Tension
7	873 80 05-00	Nut Lock Hex w/Ins. 5/16-18 unc	148	532 16 90-22	Spring Return Idler
8	532 19 30-03	Bolt 3/8-24 x 1.25 Gr. 8	149	532 16 58-98	Retainer Spring Yellow
11	532 19 39-57	Blade Mower	150	819 09 12-10	Washer 9/32 x 3/4 x 10 Ga.
13	532 19 28-72	Shaft Assembly, Mandrel, Vented	152	532 19 32-35	Clutch Cable 38"/46"
14	532 18 72-81	Housing, Mandrel, Vented	158	817 72 04-08	Screw Hex Thd Cut 1/4-20 x 1/2
15	532 11 04-85	Bearing, Ball, Mandrel	185	532 18 82-34	Head Asm Cable Clutch
18	872 14 05-05	Bolt Rdhd Sqnk 5/16-18 x 5/8	186	817 49 06-44	Screw Hex Wsh Thdrol 3/8-16 x 2-3/4
19	532 13 28-27	Bolt, Shoulder	187	532 19 34-12	Keeper Belt
20	532 40 00-95	Baffle Vortex Front	188	532 16 58-91	Bolt Carriage Idler
21	873 68 05-00	Nut	189	532 19 25-59	Stand, Brake
23	532 19 25-57	Bracket, Mower Deflector	190	532 19 25-60	Arm, Brake
24	532 10 53-04	Cap, Sleeve	191	532 19 25-61	Spacer, Brake
25	532 19 70-26	Spring, Torsion, Deflector	193	532 19 34-13	Keeper Belt RH Mandrel
26	532 11 04-52	Nut, Push	194	532 19 41-05	Guard Brake
27	532 40 16-18	Shield, Deflector	195	819 13 32-10	Washer 13/32 x 2 x 10 Ga.
29	532 13 14-91	Rod, Hinge	205	817 49 04-16	Screw 1/4-20 x 1
30	532 17 39-84	Screw Thdrol.	206	819 09 14-16	Washer 9/32 x 7/8 x 16 Ga.
31	532 18 76-90	Washer, Spacer	208	817 67 06-08	Screw 3/8-16 x 1/2
32	532 15 35-32	Pulley, Mandrel	209	532 40 92-56	Cover, Mandrel LH
33	532 40 02-34	Nut, Toplock	210	532 40 92-57	Cover, Mandrel RH
36	532 13 14-94	Pulley, Idler, Flat	214	532 19 37-82	Bolt/Washer Asm 5/16-18
37	532 19 31-98	Pulley Idler Flat	--	532 19 25-58	Brake Assembly (Includes Stand, Arm and Guard Components)
40	873 68 06-00	Nut, Crownlock 3/8-16 unc	--	532 19 28-70	Mandrel Assembly (Includes Housing, Shaft and Shaft Hardware Only - Pulley Not Included)
45	532 12 47-88	Retainer	--	532 19 36-46	Replacement Mower, Complete
46	532 13 77-29	Screw 1/4-20 x 5/8			
55	532 13 38-40	Idler Arm Assembly			
56	532 16 57-23	Spacer, Retainer			
67	532 10 69-32	Knob			
68	532 19 32-14	V-Belt			
72	532 19 32-16	Spring Brake Return			
89	819 13 13-11	Washer 13/32 x 13/16 x 11 Ga.			

NOTE: All component dimensions given in U.S. inches
1 inch = 25.4 mm

REPAIR PARTS

TRACTOR - MODEL NO. BM125B97 (96011024203), PRODUCT NO. 960 11 02-42
MOWER LIFT

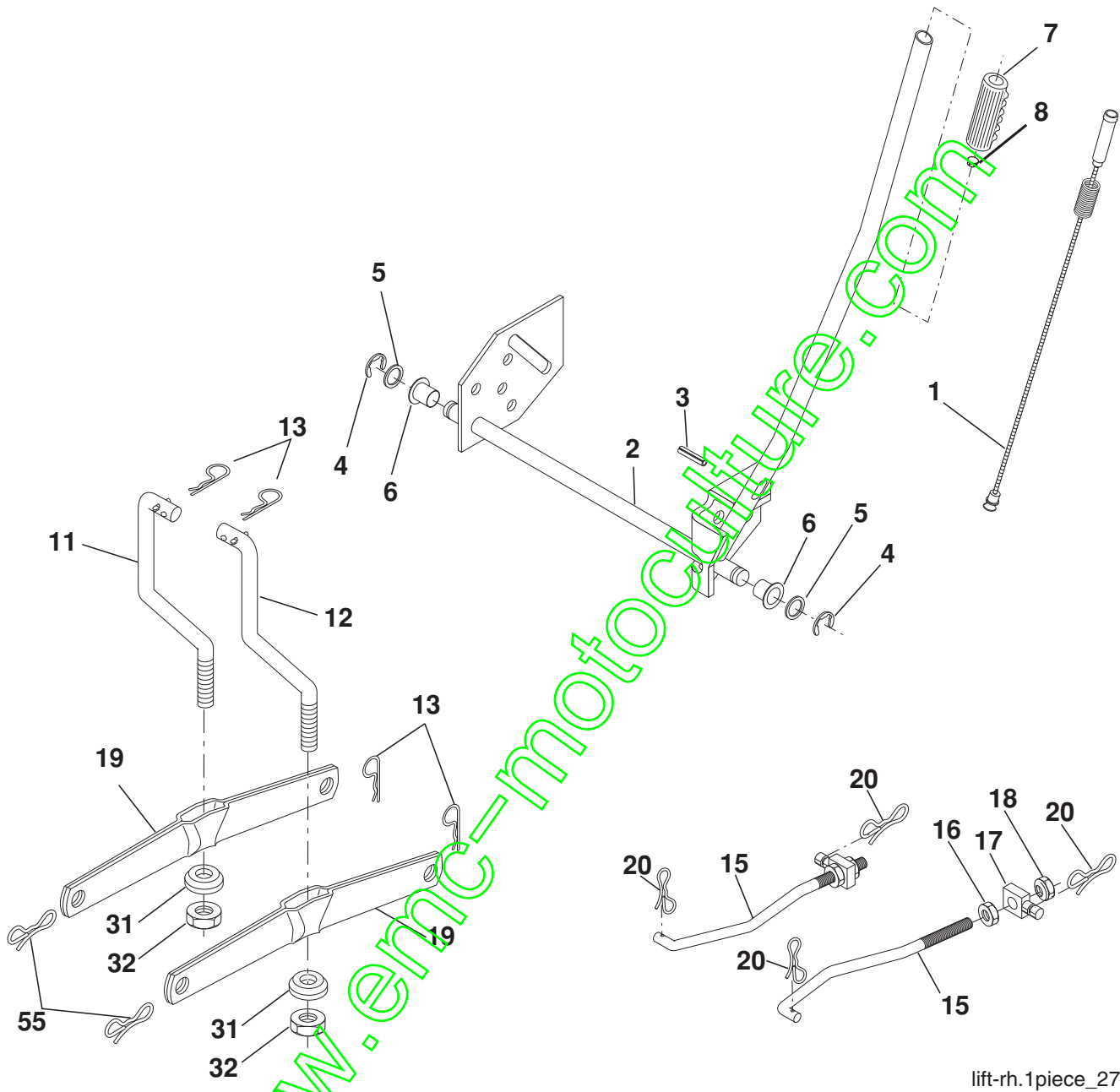

lift-rh.1piece_27

KEY NO.	PART NO.	DESCRIPTION
1	532 19 84-17	Wire Asm Inner/Spring W/plunger
2	532 19 80-70	Shaft Asm Lift
3	532 18 88-22	Pin Groove
4	812 00 00-02	E Ring #5133-62
5	819 21 16-21	Washer PLTD 21/32 x 1 x 21 Ga.
6	532 12 01-83	Bearing Nylon Blk 629 Id
7	532 10 94-13	Grip Handle
8	532 12 45-26	Button Plunger Black
11	532 13 98-65	Link Lift LH
12	532 13 98-66	Link Lift RH
13	532 12 46-70	Retainer Spring
15	532 17 32-88	Link Front

KEY NO.	PART NO.	DESCRIPTION
16	873 35 08-00	Nut Jam Hex 1/2-13 unc
17	532 17 56-89	Trunnion
18	873 80 08-00	Nut Lock W/wsh 1/2-13 unc
19	532 13 98-68	Arm Suspension Rear
20	532 19 42-09	Spring, Retainer
31	532 16 98-65	Bearing Pvt. Lift
32	873 54 06-00	Nut Crownlock 3/8-24
55	532 19 42-08	Pin Cotter 5/16 Bow Tie Lock

NOTE: All component dimensions given in U.S. inches
1 inch = 25.4 mm

SERVICE NOTES

www.emc-motoculture.com

www.emc-motoculture.com

BESTGREEN