

REPAIR PARTS MANUAL
MODEL NO. BM135B107K (96011028400)
Lawn Tractor

BESTGREEN

HOW TO USE THIS MANUAL

This manual is designed to provide the customer with a means to identify the parts on his/her tractor when ordering repair parts. The illustrations may or may not represent the actual assemblies; therefore, it is not recommended to use this manual as a guide to assemble or disassemble the tractor. Some hardware and parts are drawn larger in order to more readily identify them.

Each tractor has its own model number.

The model number for your tractor can be found on the fender under the seat.

When ordering parts, always give the following information:

- Product - "Lawn Tractor"
- Model Number - BM135B107K (96011028400)
- Part Number
- Part Description

TABLE OF CONTENTS

SCHEMATIC	3
ELECTRICAL.....	4-5
CHASSIS AND ENCLOSURES.....	6-7
DRIVE.....	8-9
STEERING WHEEL	10-11
ENGINE.....	12-13
SEAT ASSEMBLY.....	14
DECALS.....	15
MOWER DECK	16-17
MOWER LIFT.....	18

TRACTOR - MODEL NO. BM135B107K (96011028400), PRODUCT NO. 960 11 02-84 SCHEMATIC

SCH01

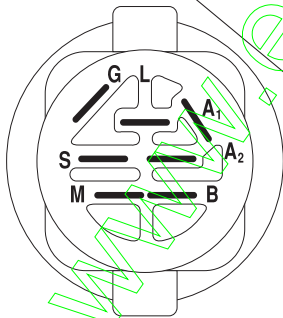
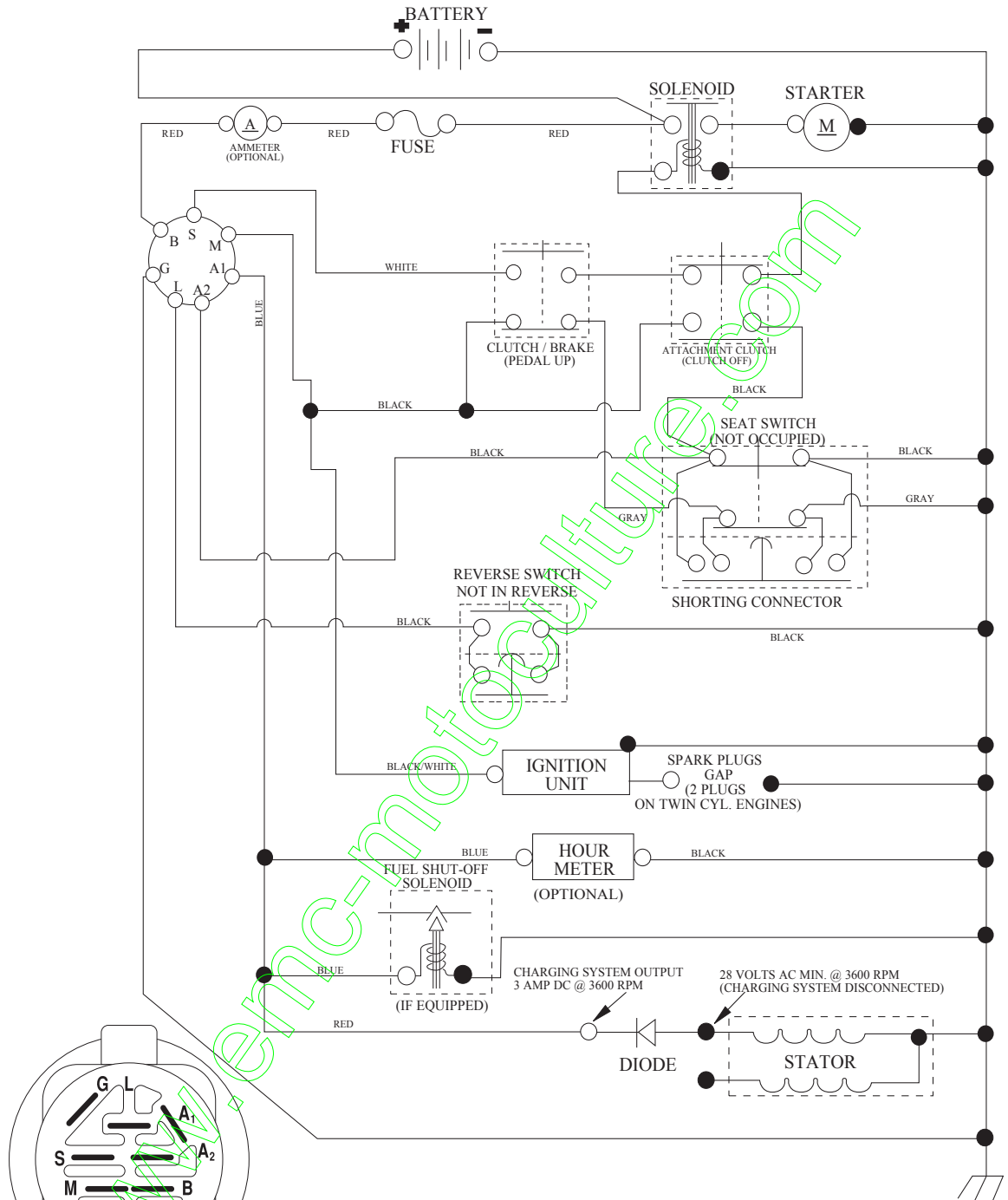

IGNITION SWITCH

POSITION	CIRCUIT	"MAKE"
OFF	M+G+A1	
RUN/OVERRIDE	B+A1	
RUN	B+A1	L+A2
START	B + S + A1	

WIRING INSULATED CLIPS
NOTE: IF WIRING INSULATED CLIPS WERE REMOVED FOR SERVICING OF UNIT, THEY SHOULD BE RE-INSTALLED TO PROPERLY SECURE YOUR WIRING.

○
REMOVABLE CONNECTIONS

●
NON-REMOVABLE CONNECTIONS

REPAIR PARTS

TRACTOR - MODEL NO. BM135B107K (96011028400), PRODUCT NO. 960 11 02-84
ELECTRICAL

KEY NO.	PART NO.	DESCRIPTION
1	532 14 49-24	Battery 12 Volt
2	874 76 04-12	Bolt Hex Hd 1/4-20 unc x 3/4
8	532 17 66-89	Box Battery
16	532 17 61-38	Switch Interlock Push-In
21	532 19 74-28	Harness Asm
24	532 42 12-99	Cable Battery 6 Ga 11" red
25	532 42 12-97	Cable Battery 6 Ga 44" red w/16 wire
26	532 17 51-58	Fuse 20 AMP
27	873 51 04-00	Nut Keps Hex 1/4-20 unc
28	532 42 12-98	Cable Ground 6 Ga 12" black
29	532 19 27-49	Switch Seat
30	532 19 33-50	Switch Ign
33	532 41 19-35	Key/Chain
40	532 19 74-28	Harness Ign.
41	871 11 04-08	Bolt Blk Fin Hex 1/4 - 20 x 1/2
42	532 13 15-63	Cover Terminal Red
43	532 19 25-07	Solenoid
90	532 18 04-49	Cover Terminal Battery
92	532 19 66-15	Harness Pigtail Consle ROS
93	532 19 25-40	Screw Plastite 10-14 x 2.0
94	532 19 18-34	Module Reverse ROS

NOTE: All component dimensions given in U.S. inches.
1 inch = 25.4 mm.

REPAIR PARTS

TRACTOR - MODEL NO. BM135B107K (96011028400), PRODUCT NO. 960 11 02-84
CHASSIS AND ENCLOSURES

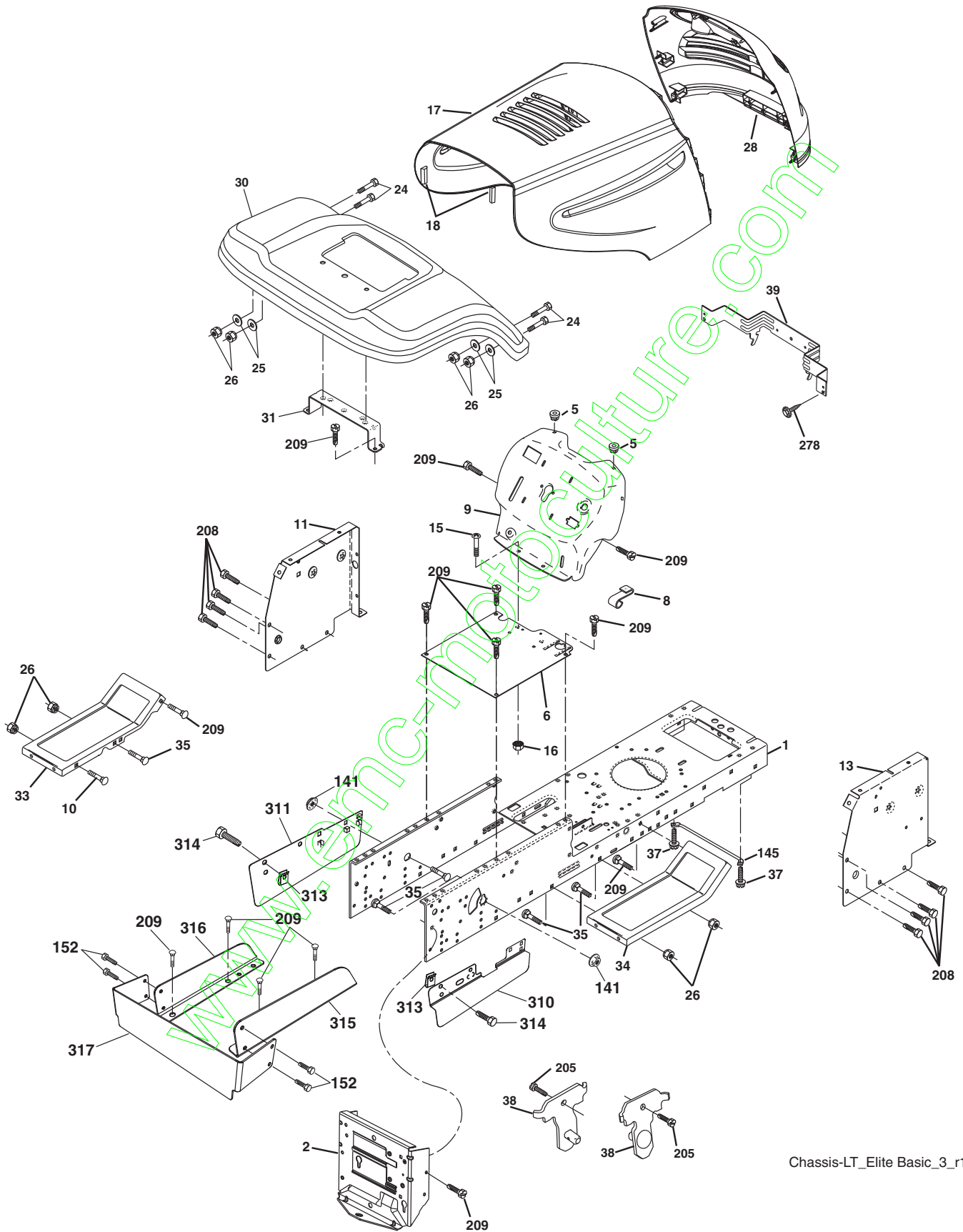

Chassis-LT_Elite Basic_3_r1

REPAIR PARTS

TRACTOR - MODEL NO. BM135B107K (96011028400), PRODUCT NO. 960 11 02-84
CHASSIS AND ENCLOSURES

KEY NO.	PART NO.	DESCRIPTION
1	532 17 46-20	Chassis
2	532 17 65-54	Drawbar
5	532 15 52-72	Bumper Hood/Dash
6	532 18 44-19	Saddle, Flat
8	532 15 51-38	Clip Retainer
9	532 19 46-88	Dash P/L
10	872 14 06-08	Bolt Carriage 3/8-16 x 1
11	532 17 49-96	Panel Dash LH
13	532 18 69-52	Panel Dash RH
15	874 18 05-12	Screw Mach. TRHD 5/16-18 unc x 3/4
16	873 51 05-00	Nut Keps 5/16-18 unc
17	532 19 24-37	Hood
18	532 18 49-21	Bumper Hood
24	874 78 06-16	Bolt Fin Hex 3/8-16unc x 1 Gr. 5
25	819 13 13-12	Washer 13/32 X 13/16 x 12 Ga
26	873 80 06-00	Nut Lock Hex w/Ins 3/8-16 Unc
28	532 18 67-18	Grille Asm. (Includes Key No's 29 and 212)
30	532 40 30-26	Fender
31	532 13 66-19	Bracket Support Fender
33	532 18 64-57	Footrest LH
34	532 18 64-58	Footrest RH
35	872 11 06-06	Bolt RDHD SHT SQNK 3/8-16 x 3/4
37	817 49 05-08	Screw Thdrol 6/16-18 x 1/2 TYT
38	532 17 57-10	Bracket, Asm. Pivot, Mower Rear
39	532 40 78-07	Bracket Pivot
141	873 90 06-00	Nut Lock Flg 3/8-16 unc
145	532 40 91-67	Rod Pivot Hood
152	817 72 04-08	Screw Thd Cut 1/4-20 x 1/2
205	817 49 06-08	Screw Thdrol 3/8-16 x 1/2
208	817 67 06-08	Screw Thdrol 3/8-16 x 1/2
209	817 00 06-12	Screw Thdr 3/8-16 x 3/4
278	532 41 63-58	Screw #10 x 0.750 BOS THREAD
310	532 42 27-66	Shield Lower RH
311	532 42 27-67	Shield Lower LH
313	532 19 66-88	Clips Threaded
314	532 13 77-29	Screw Thd Roll 1/4-20 x 5/8
315	532 42 27-71	Shield Upper RH
316	532 42 27-72	Shield Upper LH
317	532 42 28-60	Shield Rear
-	532 19 39-35	Plug Switch Light
-	532 00 54-79	Plug Button

NOTE: All component dimensions given in U.S. inches
1 inch = 25.4 mm

REPAIR PARTS

TRACTOR - MODEL NO. BM135B107K (96011028400), PRODUCT NO. 960 11 02-84
DRIVE

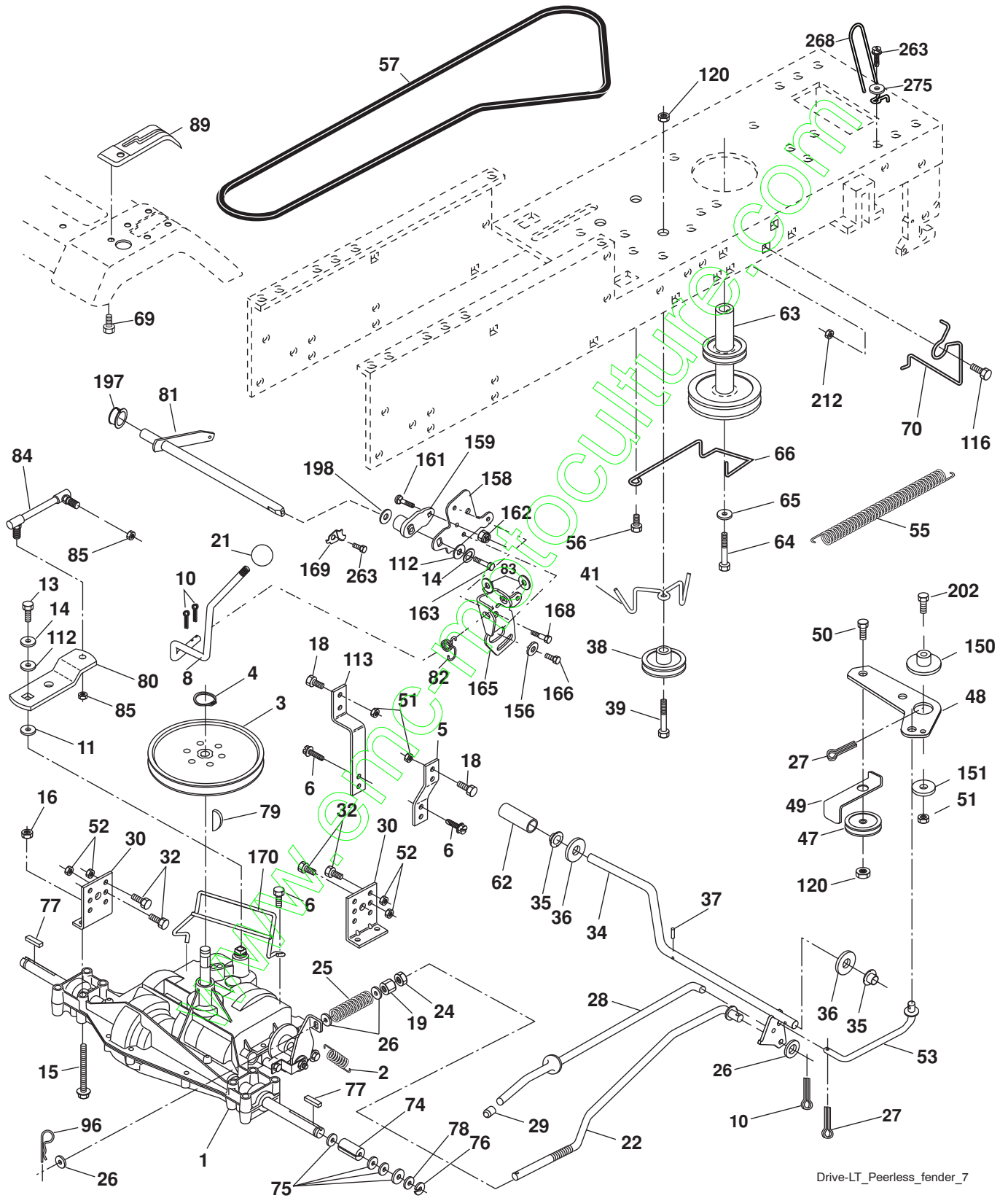

Drive-LT_Peerless_fender_7

REPAIR PARTS

TRACTOR - MODEL NO. BM135B107K (96011028400), PRODUCT NO. 960 11 02-84 DRIVE

KEY NO.	PART NO.	DESCRIPTION	KEY NO.	PART NO.	DESCRIPTION
1	-----	Transaxle, Peerless 205 544C (Order Parts From Transaxle Manufacturer)	65	810 04 07-00	Washer Lock Hvy Hlcl Spr 7/16
2	532 14 66-82	Spring Return Brake T/a Zinc	66	532 15 47-78	Keeper Belt Engine Foolproof
3	532 12 36-66	Pulley Transaxle 18" tires	69	532 14 24-32	Screw Hex Wsh Hi-Lo 1/4 X 1/4 unc
4	812 00 00-28	Ring Retainer # 5100-62	70	532 13 46-83	Guide Belt Mower Drive RH
5	532 12 15-20	Strap Torque 30 Degrees	74	532 13 70-57	Spacer Axle
6	817 06 05-12	Screw Thdrol 5/16-18 x 3/4 TYT	75	532 12 17-49	Washer 25/32 x 1 1/4 x 16 Ga.
8	532 19 27-06	Rod Shift	76	812 00 00-01	E-Ring #5133-75
10	876 02 04-16	Pin Cotter 1/8 x 1 Cad	77	532 12 35-83	Key Square 2 0 x 1845/ 1865
11	532 10 57-01	Washer Plate Shf 388 Sq Hole	78	532 12 17-48	Washer 25/32 x 1-5/8 x 16 Ga.
13	874 55 04-12	Bolt 1/4-28 Unf Gr. 8 w/Patch	79	532 12 50-96	Key Woodruff #9 3/16 x 3/4
14	810 04 04-00	Washer Lock Hvy Helical 1/4	80	532 13 14-86	Arm Shift Trans
15	874 49 05-44	Bolt 5/16-18 Gr. 5	81	532 16 55-94	Shaft Asm. Cross Taper
16	873 80 05-00	Nut Lock Hex w/lns 5/16-18	82	532 16 57-11	Spring Torsion
18	874 78 06-16	Bolt, Fin Hex 3/8-16 unc x 1 Gr. 5	83	819 17 12-16	Washer 17/32 x 3/4 x 16 Ga.
19	873 80 06-00	Nut Lock 3/8-16 unc	84	532 16 62-28	Link Trans
21	532 10 69-33	Knob	85	532 15 03-60	Nut Lock Center 1/4-28
22	532 13 08-04	Rod Brake Blk Zinc 26 840	89	532 19 58-61	Console Shift
24	873 35 06-00	Nut Hex Jam 3/8-16 unc	96	532 12 47-88	Retainer Spring 1"
25	532 10 68-88	Spring Rod Brake 2 00 Zinc	112	819 09 12-10	Washer 9/32 x 3/4 x 10 Ga.
26	819 13 13-16	Washer 13/32 x 13/16 x 16 Ga	113	532 12 72-85	Strap Torque LT
27	876 02 04-12	Pin Cotter 1/8 x 3/4 Cad	116	872 14 06-08	Bolt Rdhd Sq Neck 3/8-16 x 1
28	532 17 57-65	Rod Brake Parking LT/YT	120	873 90 06-00	Nut Lock Flg. 3/8-16
29	532 07 16-73	Cap Brake Parking Black	150	532 17 54-56	Spacer Retainer
30	532 17 49-73	Bracket Mtg Transaxle	151	819 13 32-10	Washer 13/32 x 2 x 10 Ga.
32	874 76 05-12	Bolt Hex Hd 5/16-18 unc x 3/4	156	532 16 60-02	Washer Srrtd 5/16ID x 1 x .125
34	532 17 55-78	Shaft Asm Pedal Foot	158	532 16 55-89	Bracket Shift Mount
35	532 12 01-83	Bearing Nylon Blk 629 Id.	159	532 18 39-00	Hub Shift
36	819 21 16-16	Washer 21/32 x 1 x 16 Ga.	161	872 14 04-06	Bolt RDHD SQNK 1/4-20 x 3/4 Gr. 5
37	532 12 49-63	Pin Roll 3/16 x 1"	162	873 68 04-00	Nut Crownlock 1/4-20 unc
38	532 17 91-14	Pulley Composite	163	874 78 04-16	Bolt Hex Fin 1/4-20 unc x 1 Gr.5
39	872 11 06-22	Bolt 3/8-16 x 2-3/4 Gr.5	165	532 16 56-23	Bracket Pivot Lever
41	532 17 55-56	Keeper Belt Idler Flat	166	817 49 05-10	Screw 5/16-18 x 5/8
47	532 12 77-83	Pulley Idler V-Groove Plastic	168	532 16 54-92	Bolt Shoulder 5/16-18 x .561
48	532 15 44-07	Bellcrank Clutch Grnd Drv Stl	169	532 16 55-81	Plate Fastening
49	532 12 32-05	Retainer Belt Style Spring	170	532 18 74-14	Keeper Belt T/A
50	872 11 06-12	Bolt Carr SH 3/8-16 x 1-1/2 Gr.5	197	532 16 96-13	Nyliner Snap-in 5/8
51	873 68 06-00	Nut Crownlock 3/8-16 unc	198	532 16 98-45	Washer Nylon
52	873 68 05-00	Nut Crownlock 5/16-18 unc	202	872 11 06-14	Bolt 3/8-16 x 1-3/4 Gr. 5
53	532 19 96-52	Link Clutch	212	532 14 52-12	Nut Hex Flg Lock
55	532 10 57-09	Spring Return Clutch 6 75	263	817 00 06-12	Screw Hex Wsh THDR 3/8-16 x 3/4
56	817 06 06-20	Screw 3/8-16 x 1-1/4	268	532 18 24-02	Guard Muffler
57	532 13 82-55	V-Belt Ground Drive	275	819 13 16-14	Washer 13/32 x 1 x 14 Ga.
62	532 12 48-72	Cover Pedal			
63	532 18 02-19	Engine Pulley			
64	532 17 39-37	Bolt Hex			

NOTE: All component dimensions given in U.S. inches
1 inch = 25.4 mm

REPAIR PARTS

TRACTOR - MODEL NO. BM135B107K (96011028400), PRODUCT NO. 960 11 02-84
STEERING ASSEMBLY

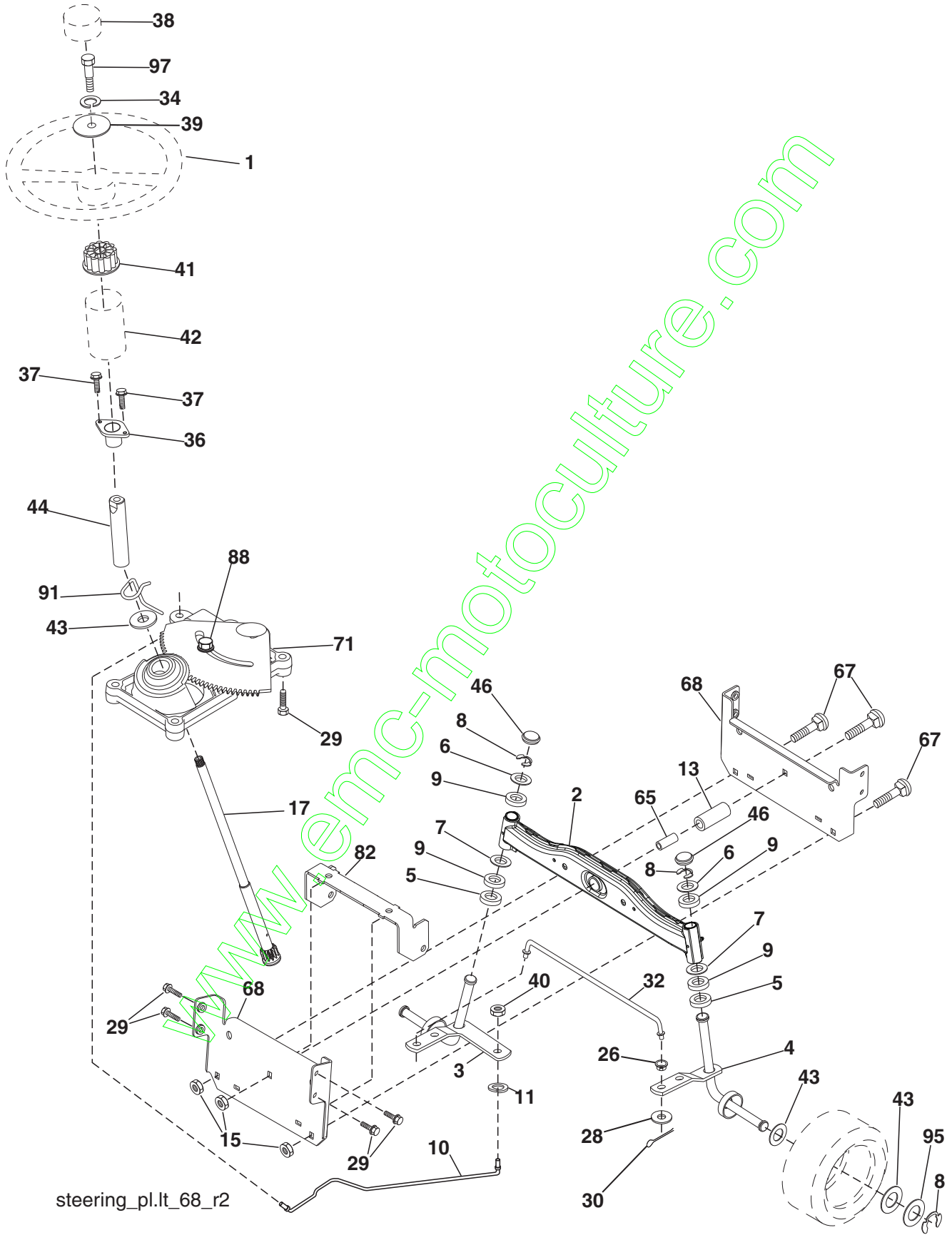

steering_pl.lt_68_r2

REPAIR PARTS

TRACTOR - MODEL NO. BM135B107K (96011028400), PRODUCT NO. 960 11 02-84
STEERING ASSEMBLY

KEY NO.	PART NO.	DESCRIPTION
1	532 19 45-95	Wheel Steering
2	532 41 81-68	Axle Asm
3	532 16 98-40	Spindle Asm LH
4	532 16 98-39	Spindle Asm RH
5	532 12 49-31	Washer Thrust .75 x 1.230
6	532 12 17-48	Washer 25/32 x 1-5/8 x 16 Ga.
7	819 27 20-16	Washer 27/32 x 1-1/4 x 16 Ga.
8	812 00 00-29	Ring Clip #t5304-75
9	532 12 49-37	Bearing Col Strg Blk
10	532 17 51-21	Link Drag
11	810 04 06-00	Washer Lock Hvy Hlcl Spr 3/8
13	532 13 65-18	Spacer Brg Axle Front
15	532 14 52-12	Nut Hex Flange Lock
17	532 19 07-53	Shaft Asm Strg
26	532 12 68-47	Bushing Link Drag Blk LR
28	819 13 14-16	Washer 13/32 x 7/8 x 16 Ga.
29	817 00 06-12	Screw 3/8-16 x 3/4
30	876 02 04-12	Pin Cotter 1/8 x 3/4 Cad
32	532 19 27-57	Rod Tie Wire Form
34	810 04 05-00	Washer Lock Hvy HLCL Spr. 5/16
36	532 15 50-99	Bushing Strg
37	532 15 29-27	Screw
38	532 19 46-03	Insert Cap Strg Wh
39	819 11 38-12	Washer 11/32- ID x 2-3/8 OD 12 Ga.
40	873 54 06-00	Nut Crownlock 3/8-24
41	532 18 67-37	Adaptor Wheel Strg
42	532 16 96-33	Boot Steering Shaft
43	532 12 17-49	Washer 25/32 x 1-1/4 x 16 Ga.
44	532 19 07-52	Extension Steering Shaft
46	532 12 12-32	Cap Spindle Fr Top Blk
65	532 41 47-36	Spacer Brace Axle
67	872 11 06-18	Bolt, Rdhd Sqnk 3/8-16 x 2-1/4
68	532 16 98-27	Axle, Brace
71	532 17 51-46	Steering Asm.
82	532 19 99-78	Bracket Susp Chassis Front
88	532 17 51-18	Bolt Shoulder 7/16-20
91	532 17 55-53	Clip Steering
95	532 18 89-67	Washer Hardened
97	874 78 05-64	Bolt 5/16-18 unc x 4" L Gr. 5

NOTE: All component dimensions given in U.S. inches.
1 inch = 25.4 mm.

REPAIR PARTS

TRACTOR - MODEL NO. BM135B107K (96011028400), PRODUCT NO. 960 11 02-84
ENGINE

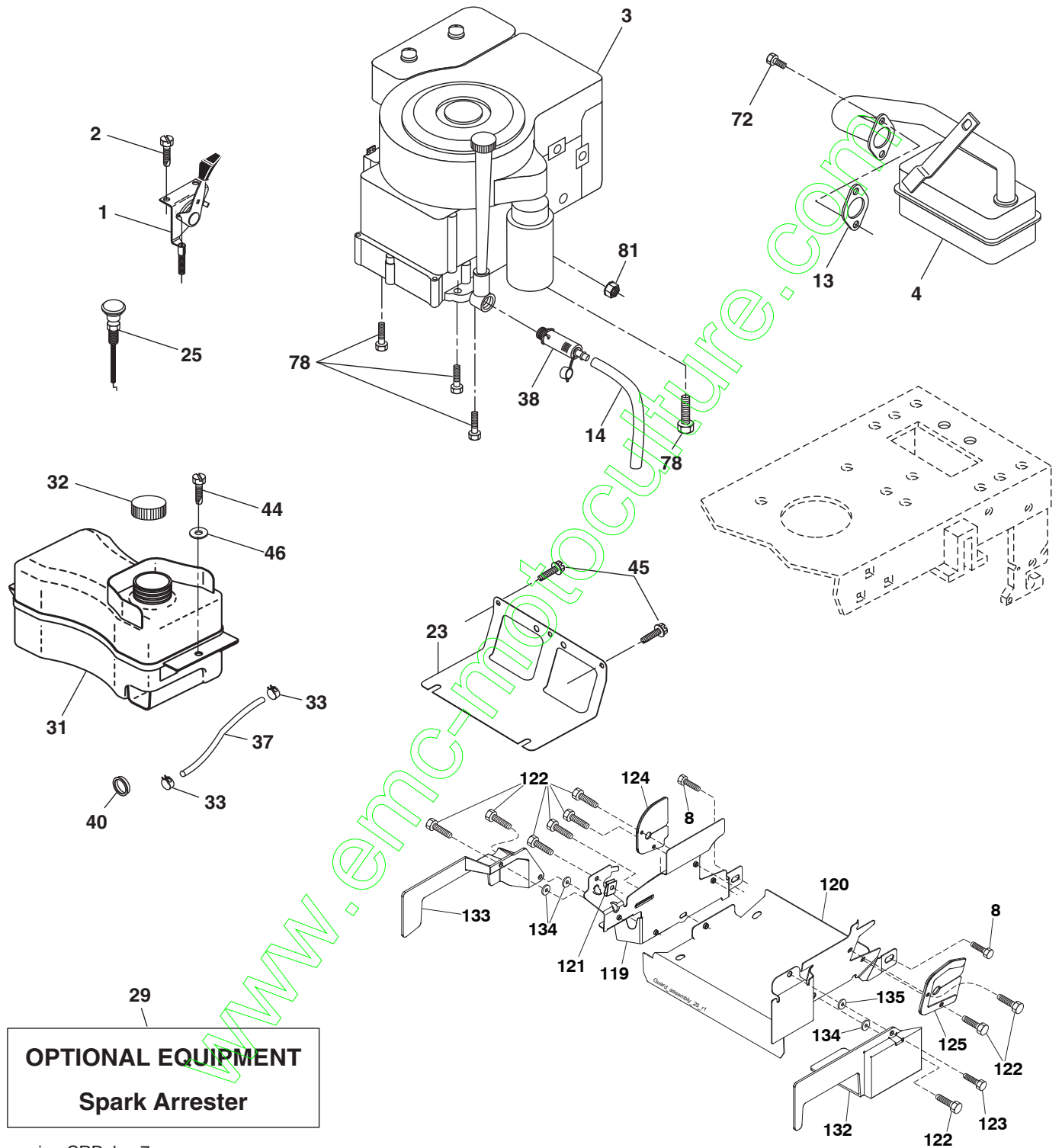

REPAIR PARTS

TRACTOR - MODEL NO. BM135B107K (96011028400), PRODUCT NO. 960 11 02-84 ENGINE

KEY NO.	PART NO.	DESCRIPTION
1	532 17 05-51	Control Throt /Ch
2	817 72 04-08	Screw Hex Thd Cut 1/4-20 x 5/8 T
3	-----	Engine B&S Model 21B807 (Order Parts from Engine Manufacturer)
4	532 17 97-58	Muffler Exhaust B&S LT
8	532 17 18-77	Bolt 5/16-18 unc x 3/4 w/Sems
13	532 16 52-91	Gasket 1 313 Id Tin Plated
14	532 14 84-56	Tube Drain Oil Easy
23	532 16 98-37	Shield Browning/Debris Guard
25	532 19 06-95	Control Choke 1 Cyl.
29	532 13 71-80	Arrester Spark
31	532 40 75-16	Tank Fuel
32	532 19 77-25	Cap Asm Fuel Top
33	532 12 34-87	Clamp Hose Blk
37	532 13 70-40	Line Fuel 20"
38	532 18 16-54	Plug Drain Oil Easy
40	532 12 40-28	Bushing Snap
44	817 67 04-12	Screw Hexwsh Thdrol 3/8-16 x 3/4
45	817 00 06-12	Screw 3/8-16 x 3/4
46	819 09 14-16	Washer 9/32 x 7/8 x 16 Ga.
72	532 19 23-34	Screw Socket Head 5/16-18 x 3/4
78	817 06 06-20	Screw 3/8-16 x 1-1/4
81	873 51 04-00	Nut Keps Hex 1/4-20 unc
119	532 19 97-68	Guard Asm Engine LH CRD
120	532 19 97-67	Guard Asm Engine RH CRD
121	532 19 66-88	Clips Threaded
122	532 13 77-29	Screw THD ROLL 1/4-20 x 5/8
123	817 67 05-08	Screw THDROL 5/16-18 x 1/2
132	532 42 07-57	Shield Side RH
133	532 42 07-56	Shield Side LH
134	532 42 30-62	1/4 PAL Nut
135	532 42 30-63	5/16 PAL Nut

NOTE: All component dimensions given in U.S. inches
1 inch = 25.4 mm

Engine Power Rating Information

The gross power rating for individual gas engine models is labeled in accordance with SAE (Society of Automotive Engineers) code J11940 (Small Engine Power & Torque Rating Procedure), and rating performance has been obtained and corrected in accordance with SAE J1995 (Revision 2002-5). Actual gross engine power will be lower and is affected by, among other things, ambient operating conditions and engine-to-engine variability. Given both the wide array of products on which engines are placed and the variety of environmental issues applicable to operating the equipment, the gas engine will not develop the rated gross power when used in a given piece of power equipment (actual "on-site" or net horsepower). This difference is due to a variety of factors including, but not limited to, accessories (air cleaner, exhaust, charging, cooling, carburetor, fuel pump, etc.), application limitations, ambient operating conditions (temperature, humidity, altitude), and engine-to-engine variability. Due to manufacturing and capacity limitations, Briggs & Stratton may substitute an engine of higher rated power for this Series engine.

REPAIR PARTS

TRACTOR - MODEL NO. BM135B107K (96011028400), PRODUCT NO. 960 11 02-84
SEAT ASSEMBLY

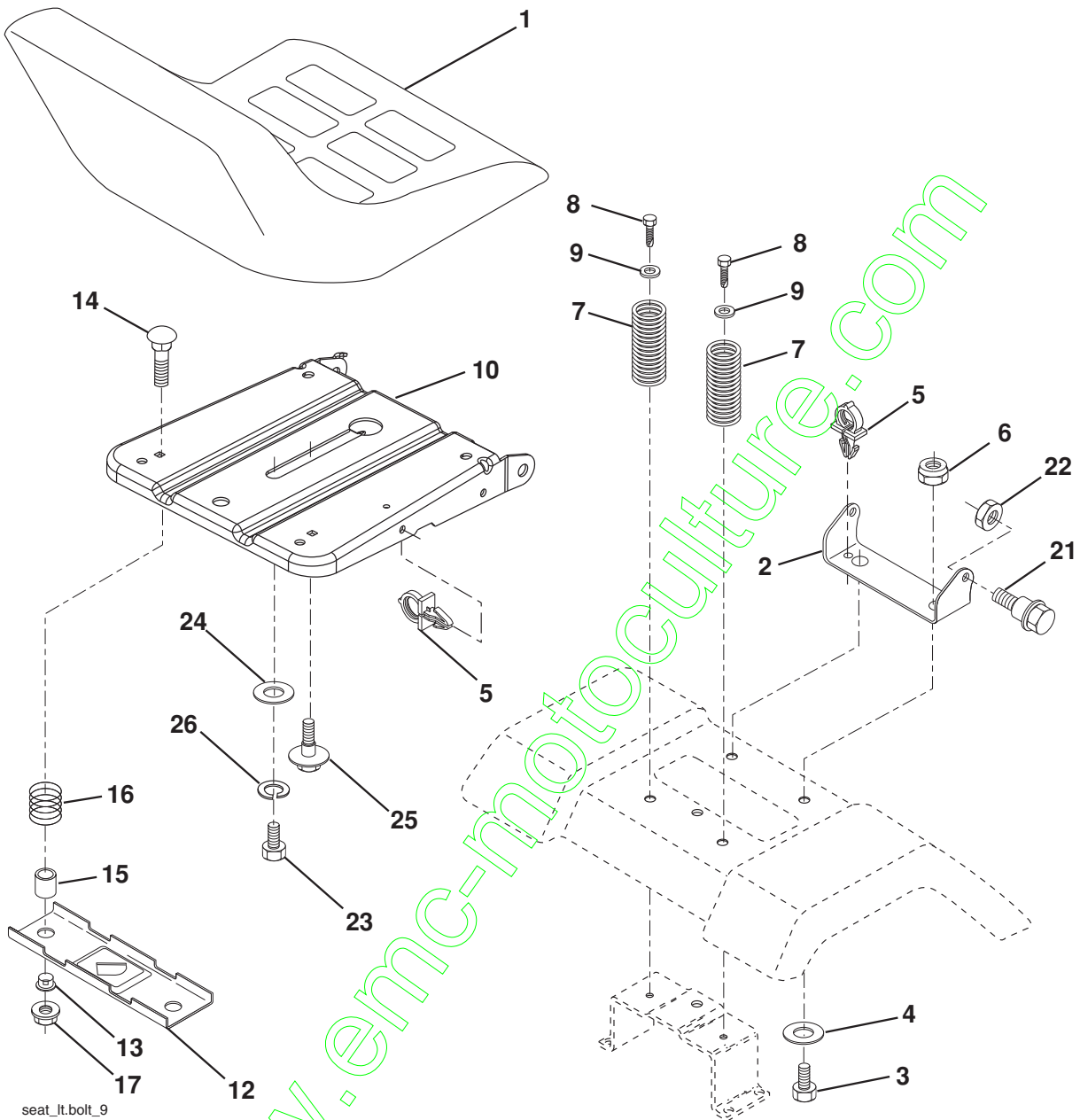

seat_lt.bolt_9

KEY NO.	PART NO.	DESCRIPTION	KEY NO.	PART NO.	DESCRIPTION
1	532 18 87-13	Seat	14	872 05 04-12	Bolt Rdhd Sqnk 1/4-20 x 1-1/2
2	532 14 05-51	Bracket Pivot Seat 8 720	15	532 13 43-00	Spacer Split 28 x 96 Yel Zinc
3	871 11 06-16	Bolt Fin Hex 3/8-16 unc x 1	16	532 12 12-50	Spring Cprsn 1 27 Blk Pnt
4	819 13 16-10	Washer 13/32 x 1 x 10 Ga	17	532 12 39-76	Nut Lock 1/4 Lge Flg Gr. 5 Zinc
5	532 14 50-06	Clip Push-In	21	532 17 18-52	Bolt Shoulder 5/16-18 unc
6	873 80 06-00	Nut Hex w/Ins. 3/8-16 unc	22	873 80 05-00	Nut Hex Lock w/Ins 5/16-18
7	532 12 41-81	Spring Seat Cprsn 2 250 Blk Zi	23	871 11 08-14	Bolt Hex
8	817 00 06-16	Screw 3/8-16 x 1-1/2	24	819 17 19-12	Washer 17/32 x 1-3/16 x 12 Ga.
9	819 13 16-14	Washer 13/32 x 1 x 14 Ga.	25	532 12 70-18	Bolt Shoulder 5/16-18 x 62
10	532 19 55-30	Pan Seat	26	810 04 08-00	Washer Lock Hvy HLCL SPR 1/2
12	532 17 46-48	Bracket Mounting Switch			
13	532 12 12-48	Bushing Snap Blk Nyl 50 Id			

NOTE: All component dimensions given in U.S. inches.
1 inch = 25.4 mm

REPAIR PARTS

TRACTOR - MODEL NO. BM135B107K (96011028400), PRODUCT NO. 960 11 02-84
DECALS

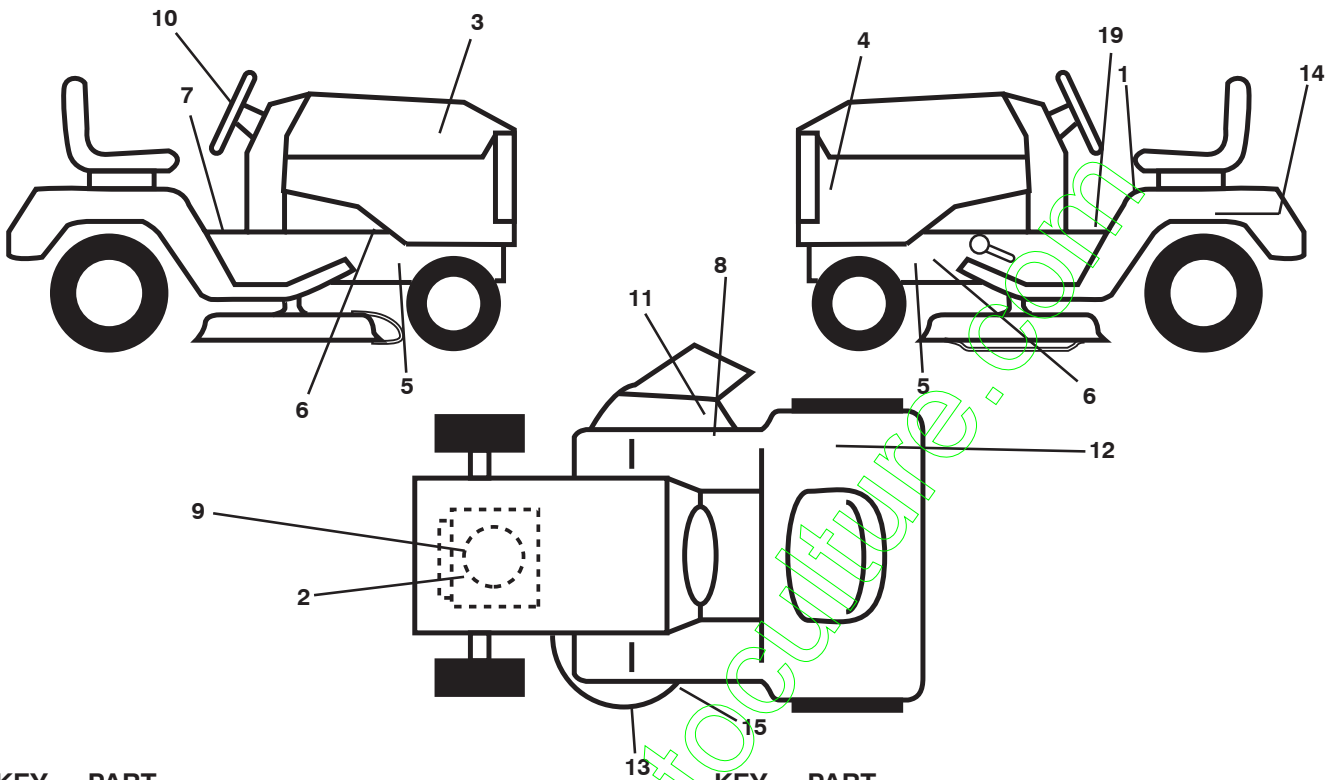

KEY NO.	PART NO.	DESCRIPTION	KEY NO.	PART NO.	DESCRIPTION
1	532 40 03-89	Decal Warning Symbols CE	12	532 18 04-32	Decal 100 DE/CE
2	532 19 68-41	Decal Warning Eng Syms.	13	532 13 49-99	Decal Mower Enviro White
3	532 42 51-76	Decal Hood RH	14	532 14 50-05	Decal Btry Dngr/PSN P/L Symbol
4	532 42 51-75	Decal Hood LH	15	532 16 03-96	Decal V-Belt
5	532 40 11-46	Decal Warning Serive Fire	19	532 14 08-37	Decal Parking Brake
6	532 15 97-36	Decal Chassis Hot Muffler	--	532 16 25-98	Decal Drawbar
7	532 15 97-37	Decal Brake/Clutch Symbol LT	--	532 13 83-11	Decal Handle Lift Height Adjust
8	532 19 63-57	Decal Deflect Warning Cutfinger	--	532 18 10-90	Pad Footrest RH
9	532 41 79-28	Decal Engine HP	--	532 18 10-91	Pad Footrest LH
10	532 19 44-19	Decal Steering Wheel	--	532 42 41-65	Manual Operator's (Euro.)
11	532 18 21-66	Decal Mower Cut Finger Symbol	--	532 42 41-66	Manual Parts

WHEELS & TIRES

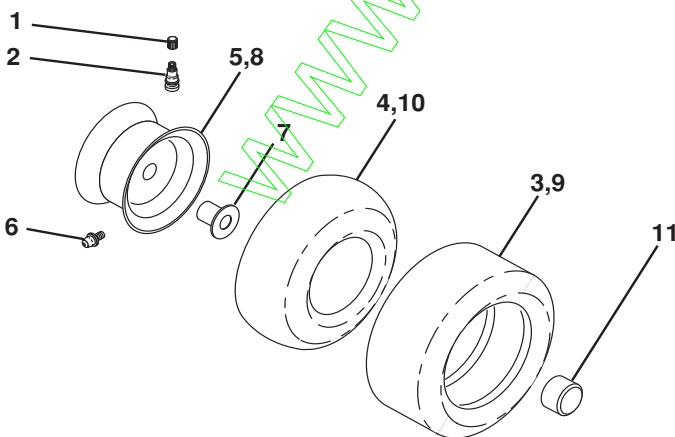

KEY NO.	PART NO.	DESCRIPTION
1	532 05 91-92	Cap Valve Tire
2	532 06 51-39	Stem Valve
3	532 12 41-57	Tire F Ts 15 x 6 0 - 6
4	532 05 99-04	Tube Front
5	532 18 33-36	Rim Asm 6" Front
6	532 12 49-57	Fitting Grease (Front Wheel Only)
7	532 12 49-59	Bearing Flange (Front Wheel Only)
8	532 18 33-37	Rim Asm 8" Rear Service
9	532 12 39-69	Tire R Ts 11 8 x 9.5-8
10	532 12 49-26	Tube Rear
11	532 17 50-39	Cap Axle Blk 1 50 x 1 00
--	532 14 43-34	Sealant, Tire (10 oz. Tube)

NOTE: All component dimensions given in U.S. inches
1 inch = 25.4 mm

REPAIR PARTS

TRACTOR - MODEL NO. BM135B107K (96011028400), PRODUCT NO. 960 11 02-84
MOWER DECK

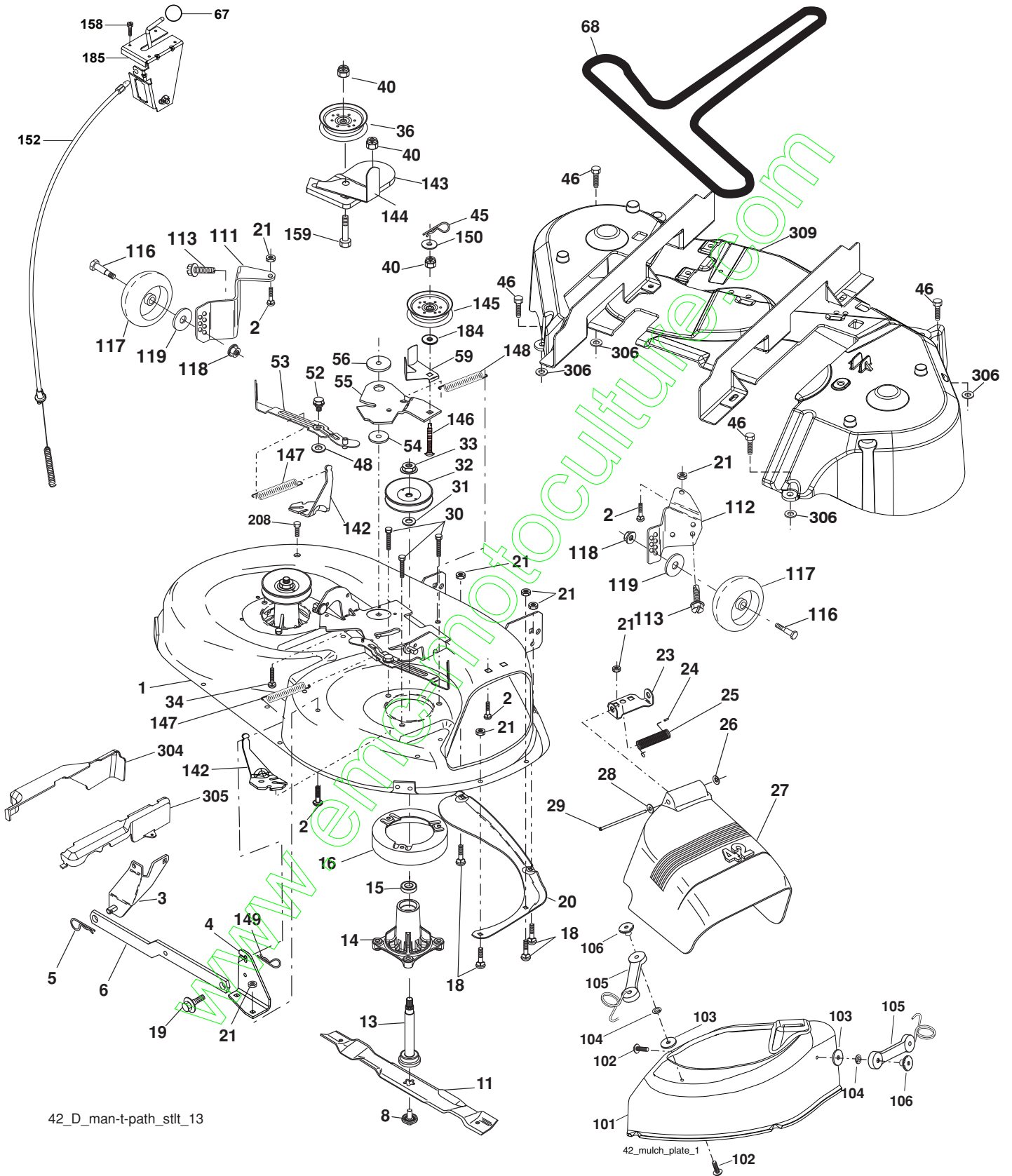

42_D_man-t-path_stlit_13

42_mulch_plate_1

REPAIR PARTS

**TRACTOR - MODEL NO. BM135B107K (96011028400), PRODUCT NO. 960 11 02-84
MOWER DECK**

KEY NO.	PART NO.	DESCRIPTION	KEY NO.	PART NO.	DESCRIPTION
1	532 16 58-92	Mower Deck Assembly, 42"	101	532 19 31-07	Cover Mulching
2	872 14 05-06	Bolt	102	871 08 10-10	Screw 10-24 x 5/8
3	532 13 80-17	Bracket Asm Fr. Sway Bar 3/42	103	819 06 12-16	Washer #10
4	532 16 54-60	Bracket Asm Deck 42" Sway Bar	104	810 07 10-00	Washer Lock
5	532 00 49-39	Retainer Spring	105	532 16 07-93	Latch Asm.
6	532 17 80-24	Bar Sway Deck	106	532 12 50-04	Nut Weld
8	532 19 30-03	Bolt/Washer Asm. 7/16-20 unf (The following Blades are available)	111	532 40 47-84	Bracket Wheel Gauge LH 42"
11	532 13 41-49	Blade, Mulching 42" Std	112	532 40 47-85	Bracket Wheel Gauge RH 42"
13	532 19 28-72	Shaft Asm. Mandrel	113	817 00 05-10	Bolt 5/16 Hex WHS
14	532 18 72-81	Housing Mandrel	116	532 00 48-98	Bolt Shld "A" 2.41 "B" 1.66
15	532 11 04-85	Bearing, Ball, Mandrel	117	532 18 86-06	Wheel Gage Half Spoked
16	532 17 44-93	Stripper, Mandrel Deck	118	873 93 06-00	Net Centerlock 3/8-16 unc
18	872 14 05-05	Bolt, Carriage 5/16-18 x 5/8	119	819 12 14-14	Washer 3/8 x 7/8 x 14 Ga.
19	532 13 28-27	Bolt, Shoulder	142	532 19 57-84	Anchor Spring Brake Mower
20	532 15 97-70	Baffle, Vortex	143	532 15 71-09	Bracket Arm Idler 42"
21	873 68 05-00	Nut	144	532 15 86-34	Keeper Belt 42" Clutch Cable
23	532 17 75-63	Bracket, Deflector Mower 42"	145	532 16 58-88	Pulley Idler Flat
24	532 10 53-04	Cap, Sleeve 80 x 112 Blk Mower	146	532 17 19-77	Bolt Carriage Idler
25	532 12 37-13	Spring, Torsion, Deflector 2 52	147	532 17 97-48	Spring Extension
26	532 11 04-52	Nut, Push Phos & Oil	148	532 16 90-22	Spring Return Idler
27	532 40 14-31	Shield, Deflector 42" Blk	149	532 16 58-98	Retainer Spring Yellow
28	819 11 10-16	Washer 11/32 x 5/8 x 16 Ga.	150	819 09 12-10	Washer 9/32 x 3/4 x 10 Ga.
29	532 13 14-91	Rod, Hinge 42" 6 75 w/G	152	532 18 15-55	Clutch Cable 42"
30	532 17 39-84	Screw Thdrol	158	817 72 04-08	Screw Hex Thd Cut 1/4-20 x 1/2
31	532 18 76-90	Washer, Spacer Mower Vented	159	872 14 06-14	Bolt Rdhd Sqn 3/8-16 unc x 1-3/4
32	532 15 35-35	Pulley, Mandrel	184	819 13 14-10	Washer 13/32 x 7/8 x 10 Ga.
33	532 40 02-34	Nut, Toplock	185	532 18 82-34	Head Asm Cable Clutch
34	872 11 06-12	Bolt Carr SH 3/8-16 x 1-1/2 Gr.5	208	817 67 06-08	Screw 3/8-16 x 1/2
36	532 13 14-94	Pulley, Idler, Flat	304	532 42 17-87	Shield Deck 42"LH
40	873 90 06-00	Nut Lock 3/8-16	305	532 42 17-88	Shield Deck 42"RH
45	532 00 44-97	Retainer	306	532 42 30-62	Palnut 1/4"
46	532 13 77-29	Screw, Thdrol 1/4-20 x 5/8 T	309	532 42 29-63	Cover Asm MDRL 42" N/TX
48	532 13 39-44	Washer, Hardened	--	532 19 28-70	Mandrel Assembly (Includes housing, shaft assembly, and bearing only - pulley/nut/washer and blade bolt/washers not included)
52	532 13 98-88	Bolt, Shoulder 5/16-18 unc	--	532 40 15-32	Replacement Mower, Complete
53	532 18 49-07	Arm Assembly, Pad, Brake			
54	532 17 85-15	Washer, Hardened			
55	532 15 50-46	Arm, Idler			
56	532 16 57-23	Spacer, Retainer			
59	532 14 10-43	Guard TUV Idler			
67	532 10 69-32	Knob Round			
68	532 18 02-15	V-Belt, 42" Mower			

NOTE: All component dimensions given in U.S. inches
1 inch = 25.4 mm

REPAIR PARTS

TRACTOR - MODEL NO. BM135B107K (96011028400), PRODUCT NO. 960 11 02-84
MOWER LIFT

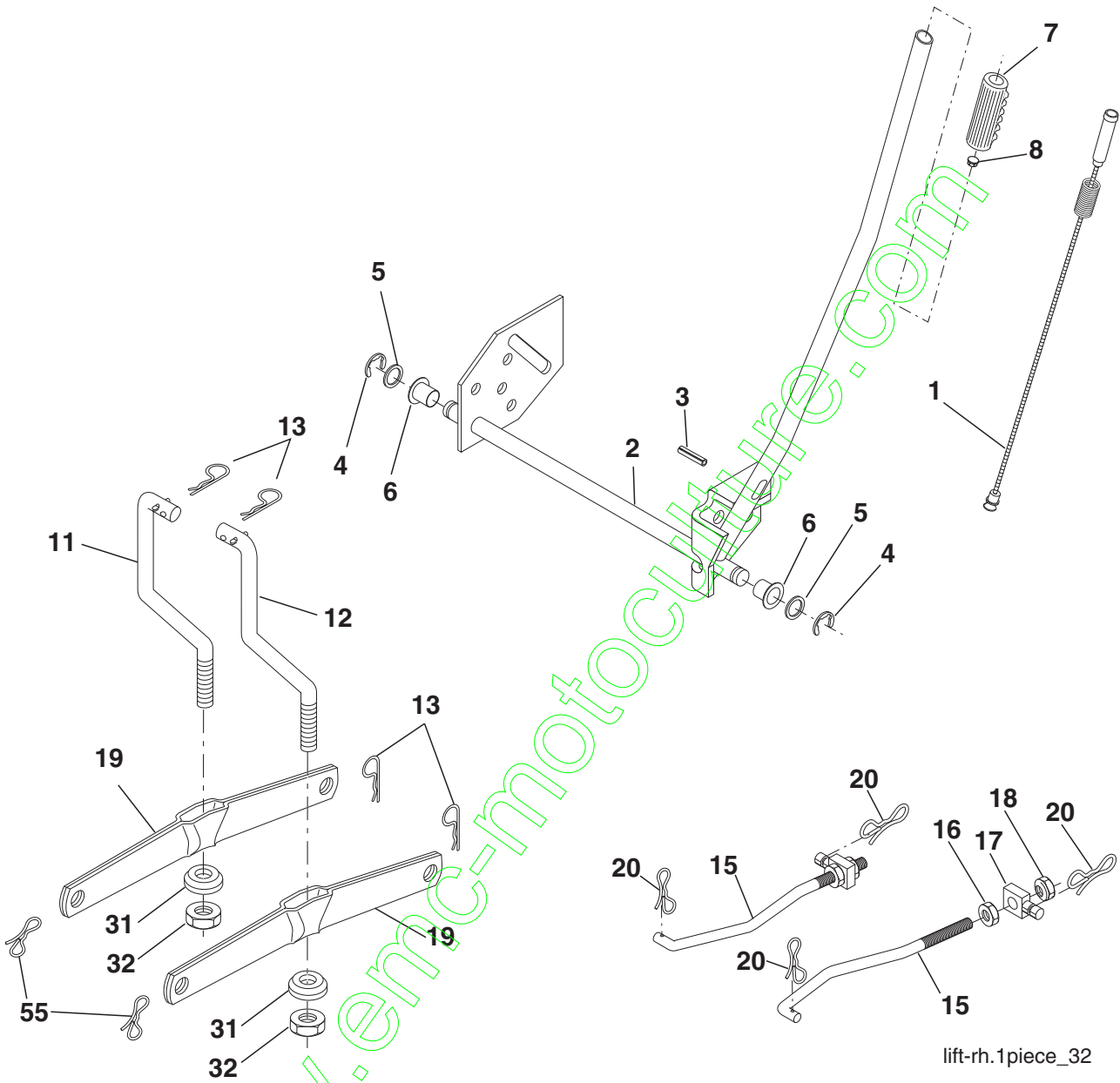

KEY NO.	PART NO.	DESCRIPTION
1	532 40 50-07	Plunger Asm. Lift Lever
2	532 19 80-70	Shaft Asm Lift
3	532 18 88-22	Pin Groove
4	812 00 00-02	E Ring #5133-62
5	819 21 16-21	Washer PLTD 21/32 x 1 x 21 Ga.
6	532 12 01-83	Bearing Nylon Blk 629 Id
7	532 10 94-13	Grip Handle
8	532 12 45-26	Button Plunger Black
11	532 13 98-65	Link Lift LH
12	532 13 98-66	Link Lift RH
13	532 12 46-70	Retainer Spring
15	532 17 32-88	Link Front

KEY NO.	PART NO.	DESCRIPTION
16	873 35 08-00	Nut Jam Hex 1/2-13 unc
17	532 17 56-89	Trunnion
18	873 80 08-00	Nut Lock w/Wsh 1/2-13 unc
19	532 13 98-68	Arm Suspension Rear
20	532 19 42-09	Spring, Retainer
31	532 16 98-65	Bearing Pvt. Lift
32	873 54 06-00	Nut Crownlock 3/8-24
55	532 16 58-98	Retainer Spring

NOTE: All component dimensions given in U.S. inches
1 inch = 25.4 mm

SERVICE NOTES

www.emc-motoculture.com

www.emc-motoculture.com

BESTGREEN