

**REPAIR PARTS MANUAL**  
**MODEL NO. BM135B92RB (96061020502)**  
**Lawn Tractor**

---

***BESTGREEN***

# HOW TO USE THIS MANUAL

This manual is designed to provide the customer with a means to identify the parts on his/her tractor when ordering repair parts. The illustrations may or may not represent the actual assemblies; therefore, it is not recommended to use this manual as a guide to assemble or disassemble the tractor. Some hardware and parts are drawn larger in order to more readily identify them.

Each tractor has its own model number.

The model number for your tractor can be found on the fender under the seat.

When ordering parts, always give the following information:

- Product - "Tractor"
- MODEL NUMBER - "BM135B92RB (96061020502)"
- Part Number
- Part Description

## TABLE OF CONTENTS

<b>SCHEMATIC .....</b>	<b>3</b>
<b>ELECTRICAL.....</b>	<b>4-5</b>
<b>CHASSIS .....</b>	<b>6-7</b>
<b>DRIVE.....</b>	<b>8-9</b>
<b>ENGINE.....</b>	<b>10-11</b>
<b>STEERING .....</b>	<b>12-13</b>
<b>MOWER DECK .....</b>	<b>14-15</b>
<b>SEAT .....</b>	<b>16</b>
<b>DECALS.....</b>	<b>17</b>
<b>MOWER LIFT.....</b>	<b>18</b>
<b>BAGGER.....</b>	<b>19</b>

# TRACTOR- -MODEL NO. BM135B92RB (96061020502), PRODUCT NO. 960 61 02-05 SCHEMATIC

SCH08

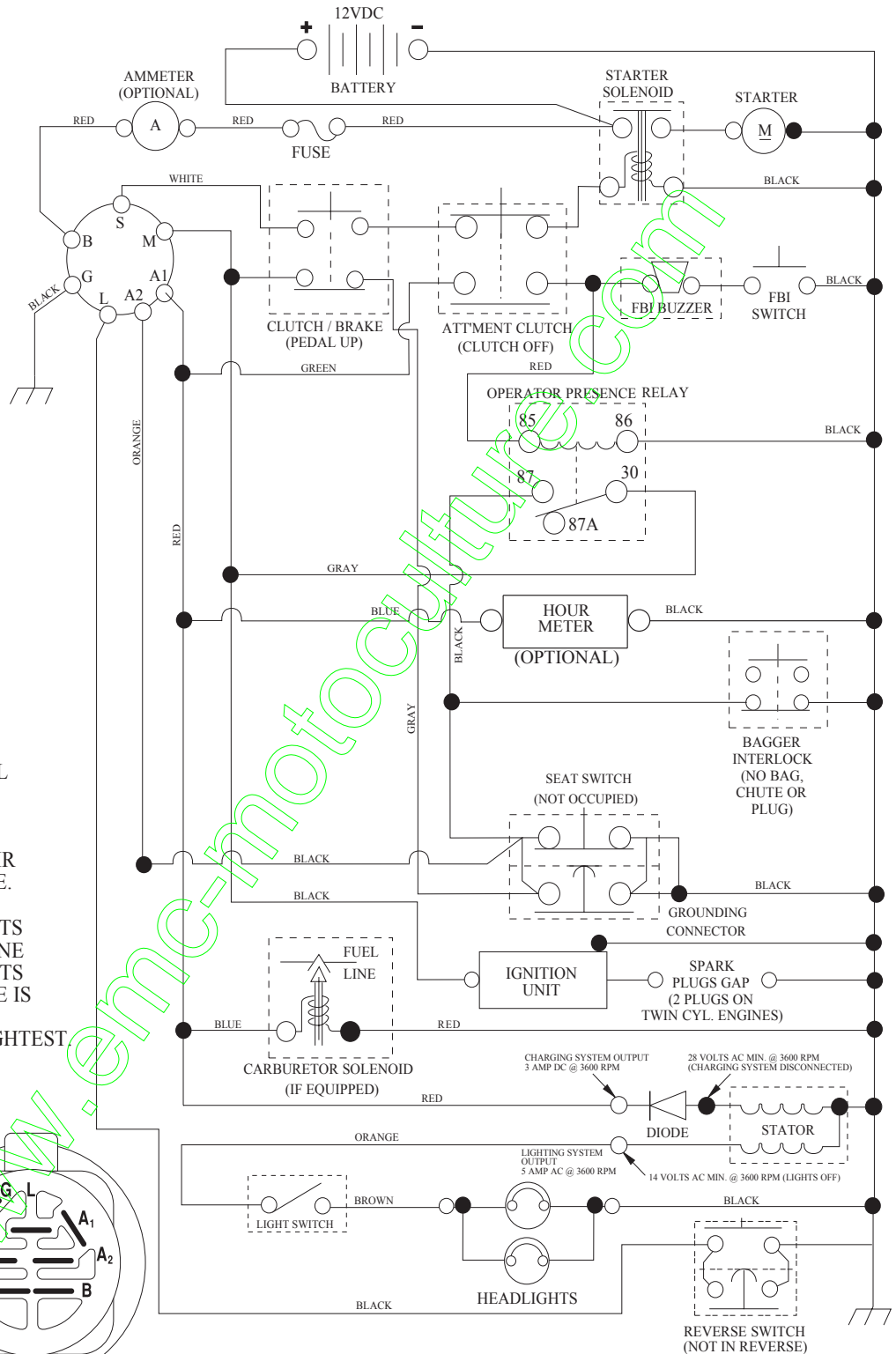

**NOTE**  
YOUR TRACTOR IS EQUIPPED WITH A SPECIAL ALTERNATOR SYSTEM. THE LIGHTS ARE NOT CONNECTED TO THE BATTERY, BUT HAVE THEIR OWN ELECTRICAL SOURCE. BECAUSE OF THIS, THE BRIGHTNESS OF THE LIGHTS WILL CHANGE WITH ENGINE SPEED. AT IDLE THE LIGHTS WILL DIM. AS THE ENGINE IS SPEEDED UP, THE LIGHTS WILL BECOME THEIR BRIGHTEST.

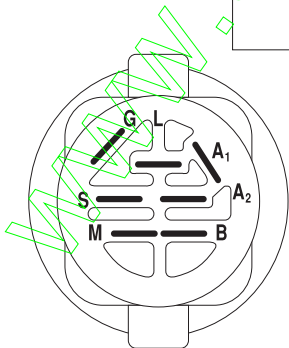

IGNITION SWITCH

POSITION	CIRCUIT "MAKE"
OFF	M+G+A1
RUN/OVERRIDE	B+A1
RUN	B+A1 L+A2
START	B + S + A1

**WIRING INSULATED CLIPS**  
NOTE: IF WIRING INSULATED CLIPS WERE REMOVED FOR SERVICING OF UNIT, THEY SHOULD BE RE-INSTALLED TO PROPERLY SECURE YOUR WIRING.

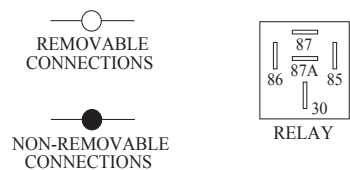

# REPAIR PARTS

TRACTOR- -MODEL NO. BM135B92RB (96061020502), PRODUCT NO. 960 61 02-05  
ELECTRICAL

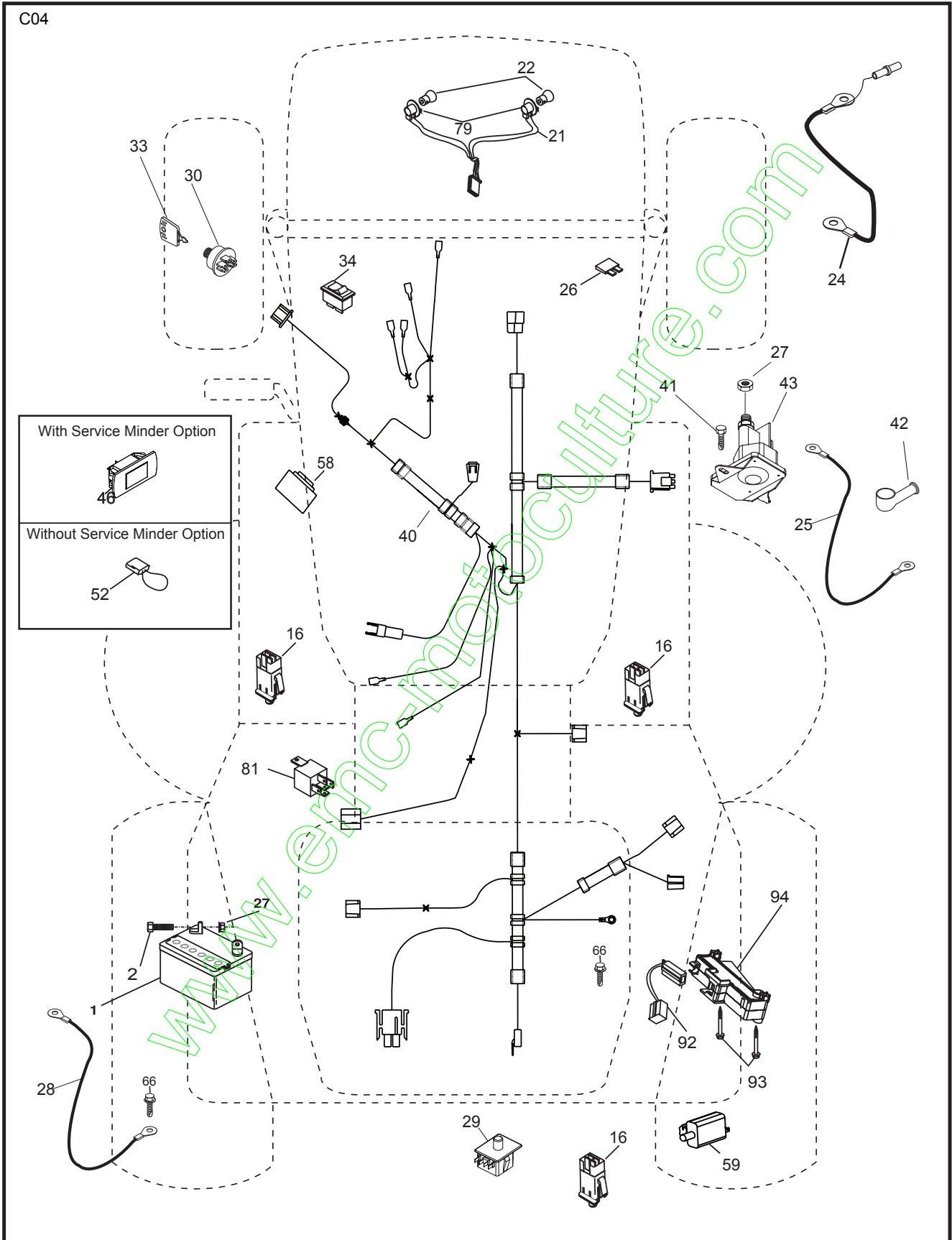

# REPAIR PARTS

TRACTOR- -MODEL NO. BM135B92RB (96061020502), PRODUCT NO. 960 61 02-05  
ELECTRICAL

KEY NO.	PART NO.	DESCRIPTION
1	532 16 34-65	Battery
2	874 76 04-12	Bolt Hex Hd 1/4-20 unc x 3/4
16	532 17 61-38	Switch Interlock
21	532 18 37-59	Harness Asm Light w/4152J
22	532 00 41-52	Bulb Light
24	532 12 47-80	Cable Starter 6 Ga. 11" Red
25	532 16 59-87	Cable Battery Crd 56" Red
26	532 17 51-58	Fuse
27	873 51 04-00	Nut Keps Hex 1/4-20 unc
28	532 12 77-25	Cable Ground 6 Ga. 18" Black
29	532 19 27-49	Switch Seat
30	532 19 33-50	Switch Ignition
33	532 41 19-35	Key/Chain
34	532 11 07-12	Switch Light/Reset B/B/RED
40	532 19 74-36	Harness Ignition
41	871 11 04-08	Bolt Flk Fin Hex 1/4-20 unc x 1/2
42	532 13 15-63	Cover Terminal Red
43	532 19 25-07	Solenoid
48	532 14 08-44	Adapter Ammeter Rectangular
58	532 16 94-19	Buzzer CRD
59	532 18 03-79	Switch FBI CRD
66	817 49 06-08	Screw Thdrol 3/8-16 x 1/2 Ty-Tt
79	532 17 52-42	Socket Asm. Bulb Twistlock
81	532 10 97-48	Relay Asm
92	532 19 66-15	Harness Pigtail Consls ROS
93	532 19 25-40	Screw Plastite 10-14 x 2.0
94	532 19 18-34	Module Reverse ROS

**NOTE:** All component dimensions given in U.S. inches.  
1 inch = 25.4 mm.

# REPAIR PARTS

TRACTOR- -MODEL NO. BM135B92RB (96061020502), PRODUCT NO. 960 61 02-05  
CHASSIS AND ENCLOSURES

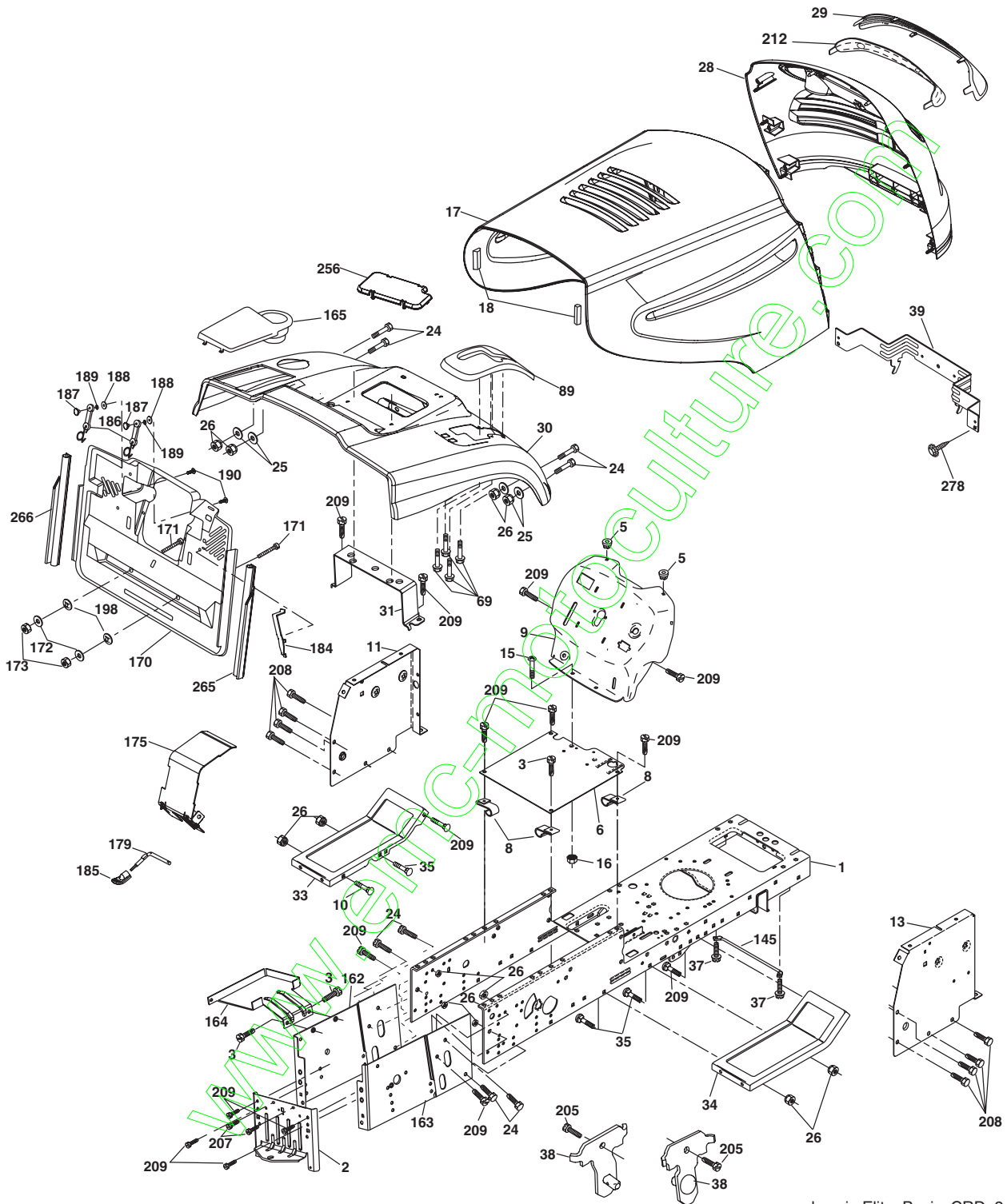

chassis-Elite\_Basic\_CRD\_3

# REPAIR PARTS

TRACTOR- -MODEL NO. BM135B92RB (96061020502), PRODUCT NO. 960 61 02-05  
CHASSIS AND ENCLOSURES

KEY NO.	PART NO.	DESCRIPTION	KEY NO.	PART NO.	DESCRIPTION
1	532 17 46-20	Chassis	145	532 40 91-67	Rod Pivot Chassis/Hood
2	532 18 03-84	Drawbar	162	532 18 03-82	Bracket Exten Chassis LH CRD
3	817 06 06-12	Screw 3/8-16 x 3/4	163	532 18 03-83	Bracket Exten Chassis RH CRD
5	532 15 52-72	Bumper Hood/Dash	164	532 16 56-05	Support Battery CRD
6	532 18 44-19	Saddle	165	532 18 13-56	Cover Battery
8	532 12 64-71	Clip Insulator 13/32 Mtg. Hole	170	532 19 94-88	Backplate Asm CRD
9	532 19 46-88	Dash	171	872 14 06-20	Bolt Rdhd Sqnk 3/8-16 x 2-1/2 Gr. 5
10	872 14 06-08	Bolt, Carriage 3/8-16 x 3/4	172	819 13 20-16	Washer 13/32 x 1-1/4 x 16 Ga.
11	532 17 49-96	Panel, Dash, LH	173	873 51 06-00	Nut, Keps Hex 3/8-16 unc
13	532 18 69-52	Panel, Asm. Dash RH	175	532 18 82-03	Door Trap
15	874 18 05-12	Screw, Machine, Truss Head 5/16-18 unc x 3/4	179	532 18 82-02	Rod Pivot FBI CRD
16	873 51 05-00	Nut	184	532 17 46-62	Bracket Actuator Bagger CRD
17	532 19 24-37	Hood	185	532 18 11-01	Knob Rod Brake Parking
18	532 18 49-21	Bumper Hood	186	532 16 07-93	Latch Asm Mulch/Bagger
24	874 78 06-16	Bolt	187	532 12 50-04	Nut Weld
25	819 13 13-12	Washer 13/32 x 13/16 x 12 Ga.	188	819 06 12-16	Washer #10
26	873 80 06-00	Nut	189	810 07 10-00	Washer Lock #10
28	532 18 38-26	Grille/Lens Asm (Includes Key #'s 29, 212)	190	871 08 10-10	Screw Pan Hd Phillip 10-24 x 5/8
29	532 18 98-37	Lens Grille	198	532 16 89-37	Nut, Push
30	532 19 73-56	Fender	205	817 49 06-08	Screw Thdrol 3/8-16 x 1/2
31	532 16 51-56	Bracket, Fender Support	207	817 67 05-08	Screw Thdrol 5/16-18 x 1/2
33	532 18 64-57	Footrest, LH	208	817 67 06-08	Screw Thdrol 3/8-16 x 1/2
34	532 18 64-58	Footrest, RH	209	817 00 06-12	Screw Hex Wsh Thdrol 3/8-16
35	872 11 06-06	Bolt	212	532 18 38-23	Insert Lens Reflective
37	817 49 05-08	Screw Thdrol 5/16-18 x 1/2 TYT	256	532 18 13-61	Cover Fender Rack CRD
38	532 18 17-48	Bracket Asm Pivot Mower Rear	265	532 18 57-04	Seal RH Side Bagger
39	532 40 78-07	Bracket Pivot Laser	266	532 18 57-03	Seal LH Side Bagger
69	532 14 24-32	Screw Hex Wsh	278	<b>532 41 63-58</b>	Screw #10 x .750 BOS Thread
89	532 19 73-39	Console	--	532 00 54-79	Plug

**NOTE:** All component dimensions given in U.S. inches.  
1 inch = 25.4 mm.

# REPAIR PARTS

TRACTOR- -MODEL NO. BM135B92RB (96061020502), PRODUCT NO. 960 61 02-05  
DRIVE

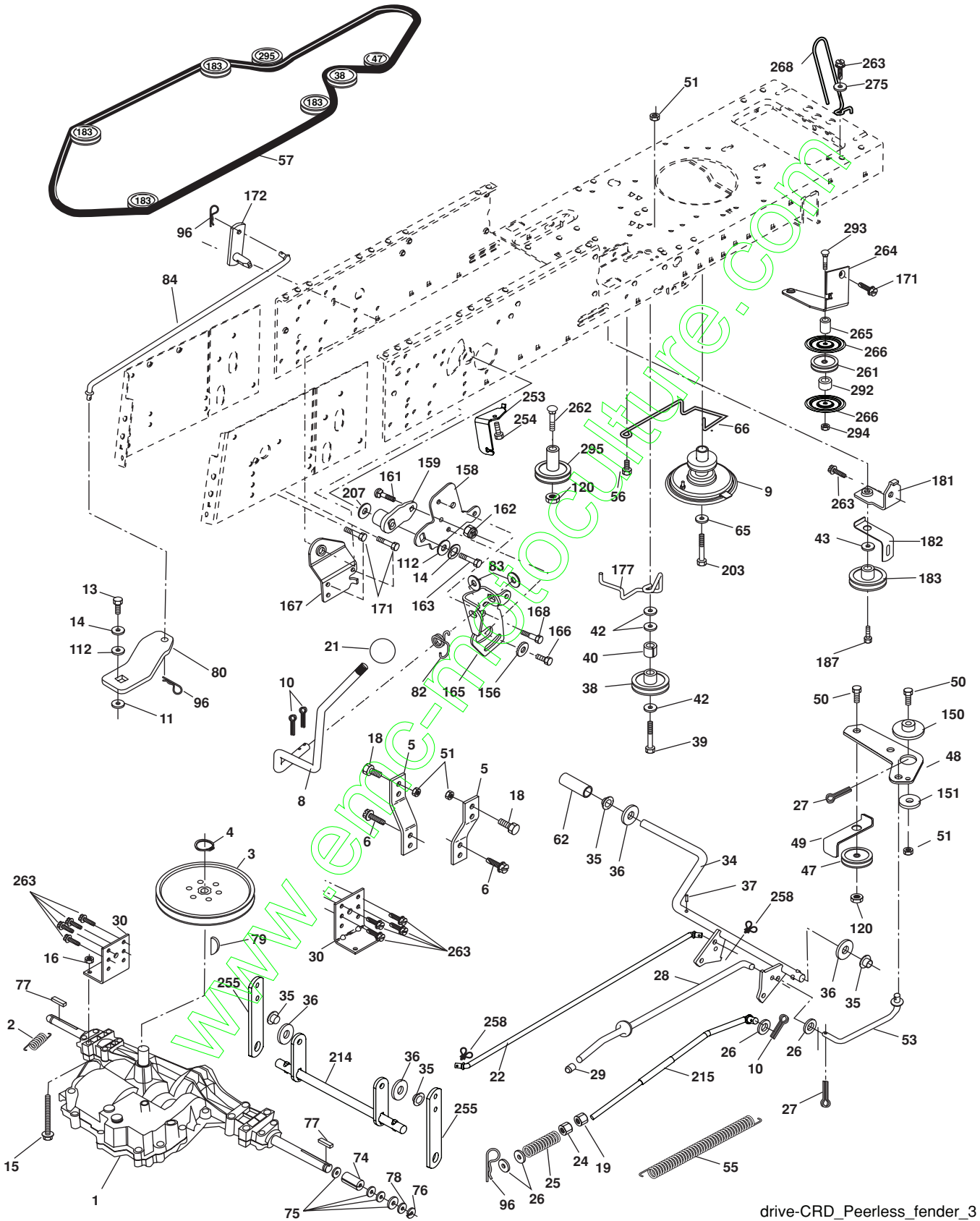

drive-CRD\_Peerless\_fender\_3



# REPAIR PARTS

TRACTOR- -MODEL NO. BM135B92RB (96061020502), PRODUCT NO. 960 61 02-05  
DRIVE

KEY NO.	PART NO.	DESCRIPTION	KEY NO.	PART NO.	DESCRIPTION
1	-----	Transaxle Peerless PMST 206-546 (Order parts from transaxle manufacturer)	78	532 12 17-48	Washer 25/32 x 1-5/8 x 16 Ga.
2	532 14 66-82	Spring Brake Return	79	532 12 50-96	Key Woodruff
3	532 16 59-99	Pulley Transaxle	80	532 14 50-90	Arm Shift PMST 20" Tires
4	812 00 00-28	Ring Retainer #5100-62	82	532 16 57-11	Spring, Torsion
5	532 12 15-20	Strap Torque 30 Degrees	83	819 17 12-16	Washer 17/32 x 3/4 x 16 Ga.
6	817 06 05-12	Screw 5/16-18 x 3/4	84	<b>532 16 56-21</b>	Link Shift CRD Pmst 18" Tires
8	532 19 27-06	Rod Shift Fender Adjust Lt	96	532 12 47-88	Spring, Retainer 1"
9	532 40 85-79	Clutch Asm Noram	112	819 09 12-10	Washer 9/32 x 3/4 x 10 Ga.
10	876 02 04-16	Pin, Cotter 1/8 x 1	120	873 90 06-00	Nut Lock 3/8-16
11	532 10 57-01	Washer Plate Shf .3888 Sq Hole	150	532 16 58-50	Bushing, Bellcrank Grnd Dr
13	874 55 04-12	Bolt 1/4-28 unf Gr. 8 w/Patch	151	819 13 32-10	Washer 13/32 x 2 x 10 Ga.
14	810 04 04-00	Washer, Lock Hvy Helical	156	532 16 60-02	Washer Srrd 5/16 ID x 1.125
15	874 49 05-44	Bolt Hex FGHD 5/16-18 x Gr. 5	158	532 16 55-89	Bracket Shift Mount
16	873 80 05-00	Nut, Lock Hex w/Ins 5/16-18 unc	159	532 18 39-00	Hub Tapered Flange Shift Lt
18	874 78 06-16	Bolt Hex 3/8-16 unc x 1 Gr. 5	161	872 14 04-06	Bolt Rdhd Sqnk 1/4-20 x 3/4 Gr. 5
19	873 80 06-00	Nut, Lock Hex w/Wsh 3/8-16 unc	162	873 68 04-00	Nut Crownlock 1/4-20 unc
21	532 10 69-33	Knob Round 1/2-13 unc Blk	163	874 78 04-16	Bolt Hex Fin 1/4-20 unc x 1 Gr. 5
22	532 17 56-07	Rod, Brake CRD Main	165	532 16 56-23	Bracket Pivot Lever
24	873 35 06-00	Nut	166	817 49 05-10	Screw 5/16-18 x 5/8
25	532 10 68-88	Spring, Rod, Brake	167	532 16 55-88	Bracket Support Shift CRD
26	819 13 13-16	Washer 13/32 x 13/16 x 16 Ga.	168	532 16 54-92	Bolt Shoulder 5/16-18 x .561
27	760 02 04-12	Pin, Cotter 1/8 x 3/4	171	817 49 06-08	Screw Thdrol 3/8-16 x 1/2 Ty-Tt
28	532 17 57-65	Rod, Parking Brake	172	<b>532 16 56-35</b>	Shaft Asm Shift Front CRD PMST
29	532 07 16-73	Cap, Parking Brake	177	532 16 59-32	Keeper Flat Idler 3.06" CRD
30	532 17 49-73	Bracket, Mfg. Transaxle	181	532 18 02-11	Bracket Idler Ground Drive CRD
34	532 17 55-78	Shaft, Asm Pedal Foot CRD	182	532 18 26-82	Keeper Belt 2.5" Od V-Idler CRD
35	532 12 01-83	Bearing, Nylon	183	532 19 95-32	Pulley V-Idler CRD
36	819 21 16-16	Washer 21/32 x 1 x 16 Ga.	187	817 58 05-20	Screw 5/16-18 x 1.25
37	532 12 49-63	Pin, Roll 3/16 x 1"	203	871 17 07-80	Bolt Hex 7/16-20 x 5
38	532 16 59-36	Pulley, Flat	207	532 16 98-45	Washer Nylon
39	874 76 06-44	Bolt Fin Hex 3/8-16 unc x 2-3/4	214	532 17 56-09	Shaft Asm. Brake
40	532 12 49-65	Spacer, Split 395 x 59 Bzp	215	532 41 01-42	Rod Brake Secondary
42	819 13 13-12	Washer 13/32 x 13/16 x 12 Ga.	253	532 17 50-28	Bracket Cable Chassis
43	819 11 10-12	Washer 11/32 x 5/8 x 12 Ga.	254	817 00 06-16	Screw 3/8-16 x 1
47	532 12 77-83	Pulley, Idler, V Groove Plastic	255	532 17 56-08	Brace Shaft Brake
48	532 15 44-07	Bellcrank Clutch Grnd Drv	258	532 17 80-62	Clip Retainer
49	532 12 32-05	Retainer, Belt Style Spring	261	532 13 14-94	Pulley Idler Flat Plated
50	872 11 06-12	Bolt Carr Sh 3/8-16 x 1-1/2 Gr. 5	262	872 11 06-22	Bolt Rdhd 3/8-16 unc x 2-3/4 Gr. 5
51	873 68 06-00	Nut, Crownlock 3/8-16 unc	263	817 00 06-12	Screw Hex Wsh THDR 3/8-16 x 3/4
53	532 19 96-52	Link, Clutch 7.66	264	532 19 76-08	Bracket Idler
55	532 10 57-09	Spring, Return, Clutch	265	532 40 46-07	Spacer Idler Chassis
56	817 06 06-20	Screw 3/8-16 x 1-1/4	266	532 18 20-61	Shield Idler
57	<b>532 16 56-31</b>	V-Belt-Kev PMST CRD	268	532 18 24-02	Guard Muffler OHV B&S RH
62	532 12 48-72	Cover, Pedal	275	819 13 16-14	Washer 13/32 x 1 x 14 Ga.
65	810 04 07-00	Washer	292	532 40 02-71	Spacer Noram CRD
66	532 15 47-78	Keeper, Belt Engine F-Proof	293	872 14 06-28	Bolt RHHD SQNK 3/8-16 x 3-1/2
74	<b>532 13 70-57</b>	Spacer Axle	294	532 19 70-33	Nut Jam 3/8-16
75	532 12 17-49	Washer 25/32 x 1-1/4 x 16 Ga.	295	532 17 91-14	Pulley Idler Composite Ext. Hub
76	812 00 00-01	Ring, E			
77	532 12 35-83	Key, Square			

**NOTE:** All component dimensions given in U.S. inches  
1 inch = 25.4 mm

# REPAIR PARTS

TRACTOR- -MODEL NO. BM135B92RB (96061020502), PRODUCT NO. 960 61 02-05  
ENGINE

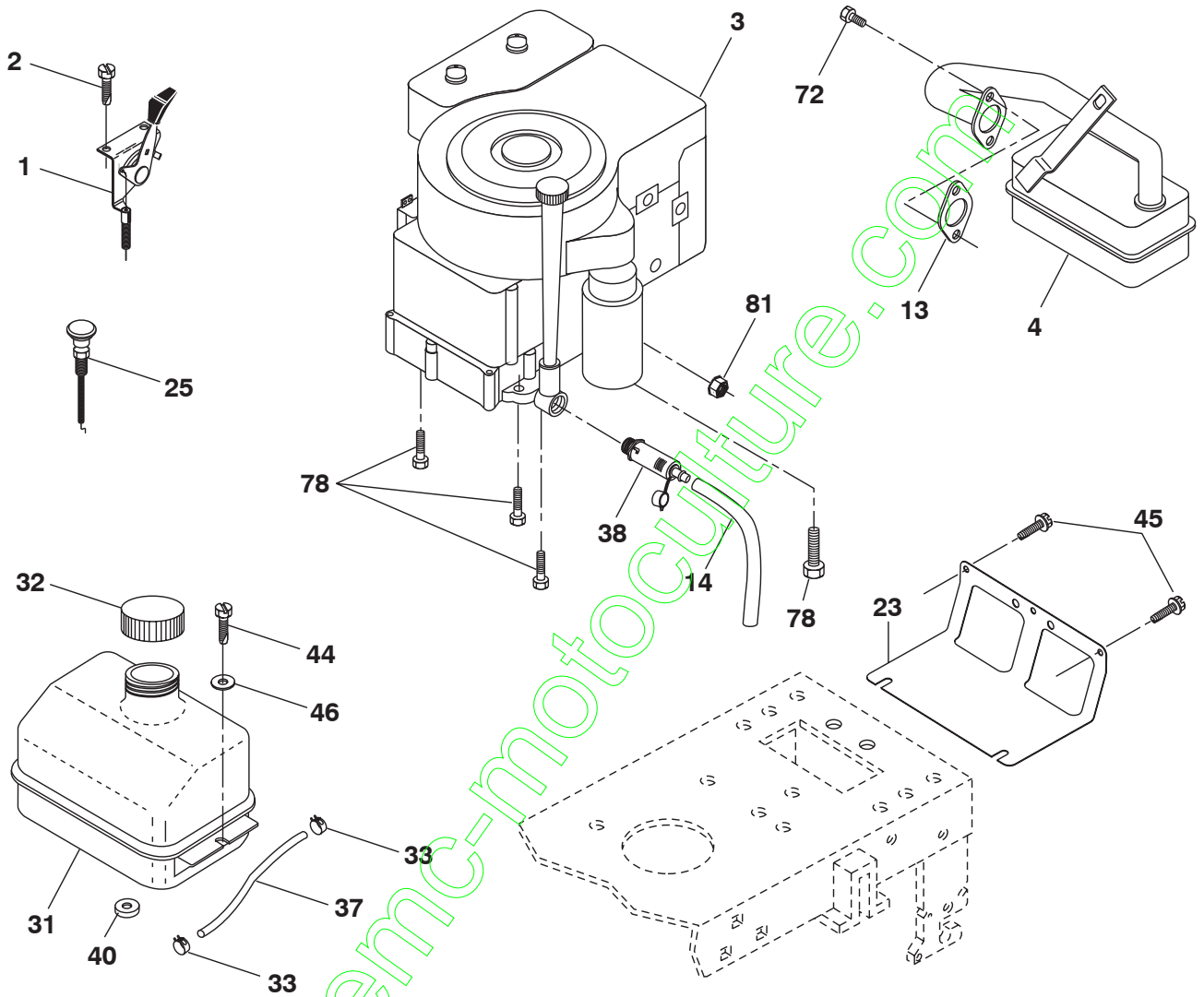

**OPTIONAL EQUIPMENT**  
**Spark Arrester**

engine-bs.1cyl\_37

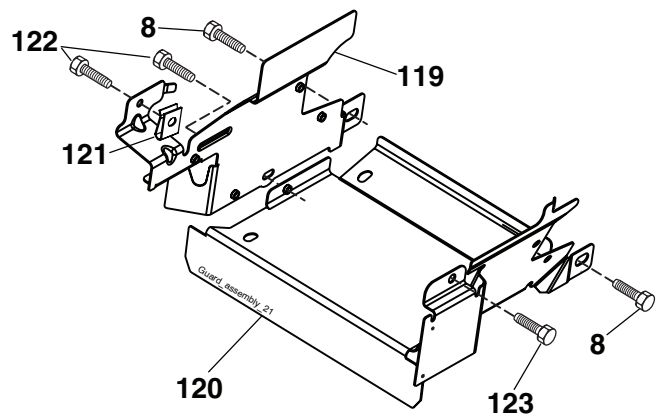

# REPAIR PARTS

TRACTOR- -MODEL NO. BM135B92RB (96061020502), PRODUCT NO. 960 61 02-05  
ENGINE

KEY NO.	PART NO.	DESCRIPTION
1	532 17 05-51	Control Throttle
2	817 72 04-08	Screw Hex Thd Cut 1/4-20 x 1/2
3	-----	Engine B&S Model 21B807 (Order Parts from Engine Manufacturer)
4	532 17 97-58	Muffler Exhaust B&S Lt
8	532 17 18-77	Bolt 5/16-18 unc x 3/4 w/Sems
13	532 16 52-91	Gasket 1 313 Id Tin Plated
14	532 14 84-56	Tube Drain Oil Easy
23	532 16 98-37	Shield Browning/Debris Guard
25	532 19 06-95	Control Choke
29	532 13 71-80	Arrestor Spark
31	532 40 75-16	Tank Fuel
32	532 19 77-25	Cap Asm Fuel Top
33	532 12 34-87	Clamp Hose Blk
37	532 13 70-40	Line Fuel 20"
38	532 18 16-54	Plug Drain Oil Easy
40	532 12 40-28	Bushing Snap
44	817 67 04-12	Screw Hexwsh Thdrol 3/8-16 x 3/4
45	817 00 06-12	Screw 3/8-16 x 3/4
46	819 09 14-16	Washer 9/32 x 7/8 x 16 Ga.
72	532 19 23-34	Screw Socket Head 5/16-18 x .75
78	817 06 06-20	Screw 3/8-16 x 1-1/4
81	873 51 04-00	Nut Keps Hex 1/4-20 unc
119	532 19 97-68	Guard Asm Eng. LH
120	532 19 97-67	Guard Asm Eng. RH
121	532 19 66-88	Clip Threaded
122	532 13 77-29	Screw THD Roll 1/4-20 x 5/8
123	817 67 05-08	Screw THD Roll 5/16-18 x 1/2

**NOTE:** All component dimensions given in U.S. inches  
1 inch = 25.4 mm

## Engine Power Rating Information

The gross power rating for individual gas engine models is labeled in accordance with SAE (Society of Automotive Engineers) code J11940 (Small Engine Power & Torque Rating Procedure), and rating performance has been obtained and corrected in accordance with SAE J1995 (Revision 2002-5). Actual gross engine power will be lower and is affected by, among other things, ambient operating conditions and engine-to-engine variability. Given both the wide array of products on which engines are placed and the variety of environmental issues applicable to operating the equipment, the gas engine will not develop the rated gross power when used in a given piece of power equipment (actual "on-site" or net horsepower). This difference is due to a variety of factors including, but not limited to, accessories (air cleaner, exhaust, charging, cooling, carburetor, fuel pump, etc.), application limitations, ambient operating conditions (temperature, humidity, altitude), and engine-to-engine variability. Due to manufacturing and capacity limitations, Briggs & Stratton may substitute an engine of higher rated power for this Series engine.

# REPAIR PARTS

TRACTOR- -MODEL NO. BM135B92RB (96061020502), PRODUCT NO. 960 61 02-05  
STEERING ASSEMBLY

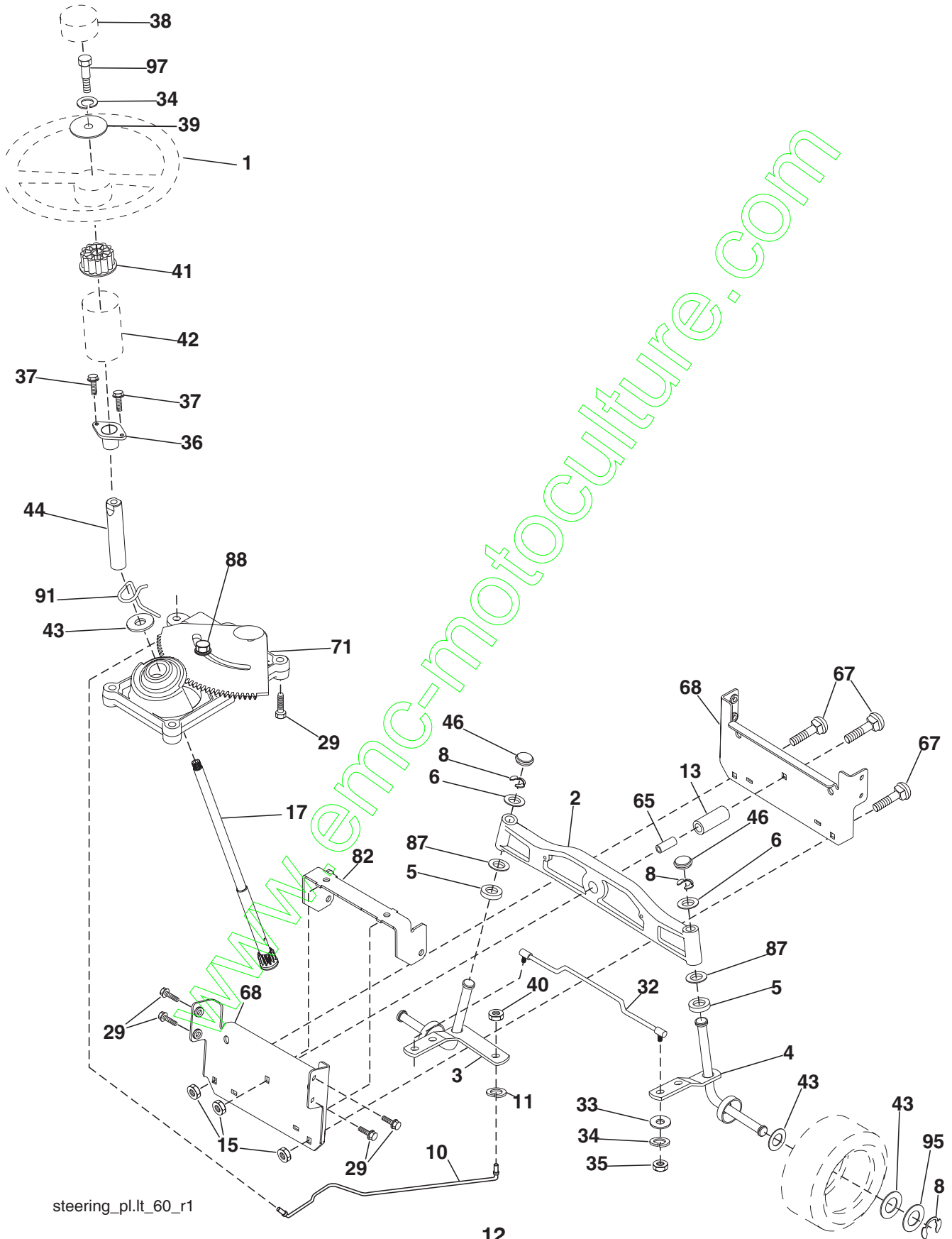

# REPAIR PARTS

TRACTOR- -MODEL NO. BM135B92RB (96061020502), PRODUCT NO. 960 61 02-05  
STEERING ASSEMBLY

KEY NO.	PART NO.	DESCRIPTION
1	532 19 45-95	Steering Wheel
2	532 18 47-06	Front Axle Assembly
3	532 16 98-40	Spindle Assembly, LH
4	532 16 98-39	Spindle Assembly, RH
5	532 12 49-31	Bearing, Race, Thrust, Hardened
6	532 12 17-48	Washer 25/32 x 1-5/8 x 16 Ga.
8	812 00 00-29	Ring, Clip
10	532 17 51-21	Link, Drag
11	810 04 06-00	Washer, Lock
13	532 13 65-18	Spacer Axle
15	532 14 52-12	Nut Hex Flange Lock
17	532 19 07-53	Shaft Assembly, Steering
29	817 00 06-12	Screw 3/8-16 x 3/4
32	532 17 01-62	Rod, Tie
33	819 11 12-16	Washer 11/32 x 3/4 x 16 Ga.
34	810 04 05-00	Washer Lock Hvy Hlcl Spr 5/16
35	873 54 05-00	Crownlock Nut 5/16-24 unf
36	532 15 50-99	Bushing, Steering
37	532 15 29-27	Screw TT #10-32 x 5 x 3/8 Flange
38	532 19 46-03	Cap Wheel Steering
39	819 11 38-12	Washer 11/32 x 2-3/8 12 Ga.
40	873 54 06-00	Nut Crownlock 3/8-24
41	532 18 67-37	Adapter, Steering Wheel
42	532 16 96-33	Boot, Steering Dash P/L Mtl
43	532 12 17-49	Washer 25/32 x 1-1/4 x 16 Ga.
44	532 19 07-52	Extension Steering
46	532 12 12-32	Cap, Spindle
65	532 41 47-36	Spacer Axle
67	872 11 06-18	Bolt Rdhd Sq 3/8-16 x 2-1/4
68	532 16 98-27	Brace Axle
71	532 17 51-46	Steering Asm.
82	532 19 99-78	Bracket Susp. Chassis Front
87	532 17 39-66	Washer Flat .781 x 1-1/2 x .14
88	532 17 51-18	Bolt Shoulder 7/16-20 unc
91	532 17 55-53	Clip Steering
95	532 18 89-67	Washer
97	874 78 05-64	Bolt 5/16-18 unc x 4" L Gr. 5

**NOTE:** All component dimensions given in U.S. inches.  
1 inch = 25.4 mm.

# REPAIR PARTS

TRACTOR- -MODEL NO. BM135B92RB (96061020502), PRODUCT NO. 960 61 02-05  
MOWER

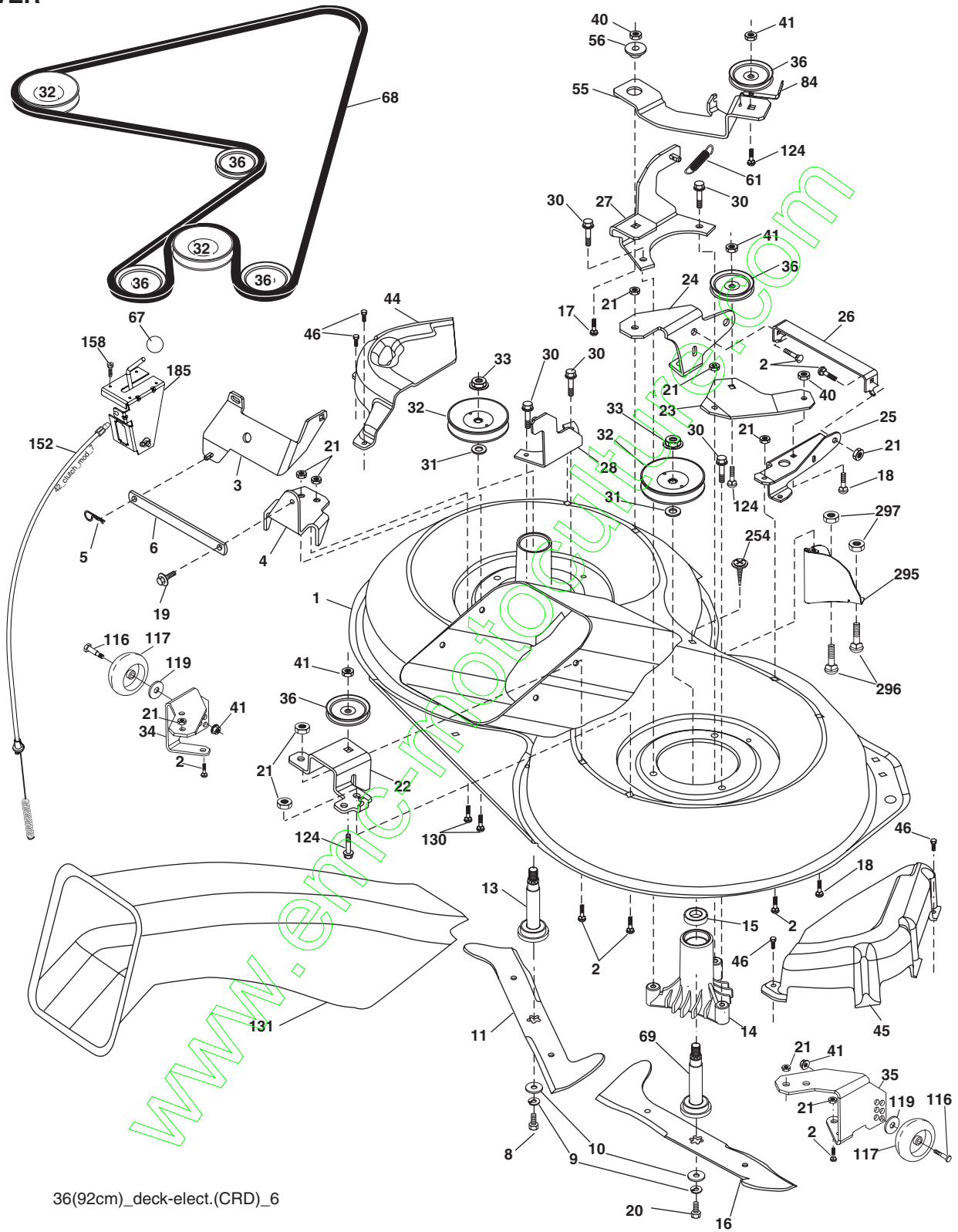

36(92cm)\_deck-elect.(CRD)\_6

# REPAIR PARTS

TRACTOR- -MODEL NO. BM135B92RB (96061020502), PRODUCT NO. 960 61 02-05  
MOWER

KEY NO.	PART NO.	DESCRIPTION	KEY NO.	PART NO.	DESCRIPTION
1	532 40 01-08	Housing Asm. Mower	44	532 17 55-38	Cover Mandrel LH
2	872 14 05-06	Bolt Rdhd Sqnk 5/16-18 unc x 3/4	45	532 17 55-39	Cover Mandrel RH
3	532 16 55-69	Bracket Asm. S-Bar Chass	46	532 13 77-29	Screw Thd Roll 1/4-20 x 5/8
4	532 16 55-58	Bracket Bar Sway Deck	55	532 19 94-98	Arm Idler
5	532 12 46-70	Retainer Spring	56	532 16 57-23	Spacer Retainer PM Mower
6	532 16 55-57	Bar Sway	61	532 19 94-86	Spring Tension Belt
8	532 18 17-12	Bolt 3/8-24 x 1.25 Gr. 8 Patched	67	532 10 69-32	Knob Rd 3/8-16 Plstc Thds Blk
9	810 03 06-00	Washer Lock Hvy 3/8 Unplated	68	532 40 20-08	Hex-Belt 92 Mower
10	532 14 02-96	Washer Hard Blade Mower Vented	69	532 16 54-82	Shaft Asm w/Lwr Brg Rh Thd CRD
11	532 18 63-85	Blade 3-1 LH	84	532 15 60-85	Keeper Belt Idler
13	532 13 76-45	Shaft Asm. w/Lower Bearing	116	532 19 34-06	Bolt Shoulder
14	532 12 87-74	Housing Mandrel Vented (Machd)	117	532 17 48-73	Wheel Gauge
15	532 11 04-85	Bearing Ball Mandrel	119	819 13 20-12	Washer 13/32 x 1-1/4 x 12 Ga.
16	532 18 63-86	Blade 3-1 RH	124	872 11 06-12	Bolt Carr Sh 3/8-16 x 1-1/2 Gr. 5
17	872 14 06-10	Bolt Carriage 3/8-16 x 1-1/4	130	872 11 05-06	Bolt Rdhdsqnk 5/16-18 unc x 3/4
18	872 11 06-06	Bolt Rdhd Sqnk 3/8-16 x 3/4	131	532 16 56-61	Chute Bagger CRD
19	532 13 28-27	Bolt Shoulder 5/16-18 Thd Form	152	532 17 60-74	Cable Clutch CRD Service
20	532 18 17-13	Bolt 3/8-24 x 1.25 Gr. 8 Ptch Lhthd	158	817 72 04-08	Screw Hex Thdcut 1/4-20 x 5/8
21	873 68 05-00	Nut Crown Lock 5/16-18	185	532 18 82-34	Head Asm. Cable Clutch
22	532 19 95-90	Bracket Idler Sprt	254	817 00 06-16	Screw 3/8-16 x 1
23	532 16 54-46	Bracket Idler Sprt RF	295	532 41 21-71	Baffle Front
24	532 16 52-42	Bracket Suspension LF	296	872 14 04-06	Bolt 1/4-20 x 3/4 Gr. 5
25	532 16 52-44	Bracket Suspension RF	297	873 93 04-00	Nut Centerlock 1/4-20 unc
26	532 40 01-10	Brace Support Susp Frt CRD	--	532 18 18-57	Mandrel Assembly (Includes housing, shaft assembly, and bearing only - pulley/nut/washer and blade bolt/washers not included)
27	532 16 55-68	Bracket Asm. Susp RR	--	532 18 18-58	Mandrel Asm CRD LH Threads SVC
28	532 16 55-67	Bracket Asm. Susp LR	--	532 41 37-11	Replacement Mower Complete - (Std. Deck - Order separately gauge wheel components Key Nos. 116-119 and 41)
30	532 17 39-84	Screw Thd Rolling Washer Head			
31	532 18 76-90	Washer Spacer			
32	532 15 35-32	Mandrel Pulleys			
33	532 40 02-34	Nut Flg Top Lock			
34	532 40 01-07	Bracket Gauge Wheel LF			
35	532 40 01-06	Bracket Gauge Wheel RF			
36	532 14 67-63	Pulley Idler V-Groove Dim 4.25			
40	873 68 06-00	Nut Crownlock 3/8-16 unc			
41	873 90 06-00	Mut Lock Flg 3/8-16 unc			

**NOTE:** All component dimensions given in U.S. inches  
1 inch = 25.4 mm

# REPAIR PARTS

TRACTOR- -MODEL NO. BM135B92RB (96061020502), PRODUCT NO. 960 61 02-05  
SEAT ASSEMBLY

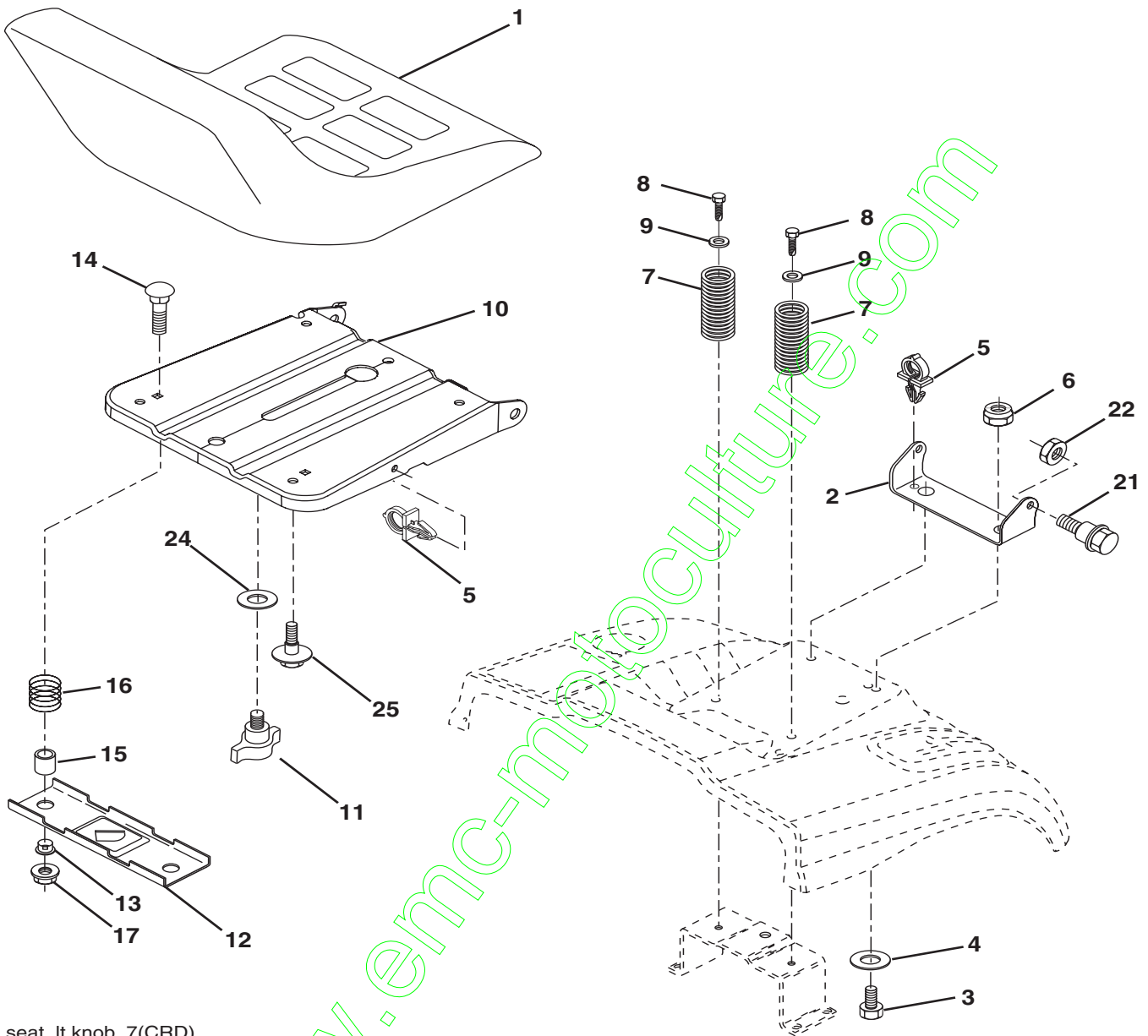

seat\_lt.knob\_7(CRD)

KEY NO.	PART NO.	DESCRIPTION
1	532 18 87-13	Seat
2	532 14 05-51	Bracket Pivot Seat
3	871 11 06-16	Bolt Fin Hex 3/8-16 x 1 Blk
4	819 13 16-10	Washer Flat 13/32 x 1 x 10 Ga.
5	532 14 50-06	Clip Push In Hinged
6	873 80 06-00	Nut Lock Hex w/Insert 3/8-16
7	532 12 41-81	Spring Seat Cprsn 2 250 Blk Zi
8	817 00 06-16	Screw 3/8-16 x 1.5
9	819 13 16-14	Washer 13/32 x 1 x 14 Ga.
10	532 19 55-30	Pan Seat
11	532 16 63-69	Knob Seat Adj. Wingnut
12	532 17 46-48	Bracket Pnt Mounting Switch

KEY NO.	PART NO.	DESCRIPTION
13	532 12 12-48	Bushing Snap Blk Nyl 50 Id
14	872 05 04-12	Bolt Rdhd Sht Nk 1/4-20 x 1-1/2
15	532 13 43-00	Spacer Split
16	532 12 12-50	Spring Cprsn
17	532 12 39-76	Nut Lock 1/4 Lge Flg Gr. 5 Zinc
21	532 17 18-52	Bolt Shoulder 5/16-18 unc-2A
22	873 80 05-00	Nut Hex Lock w/Ins 5/16-18
24	819 17 19-12	Washer 17/32 x 1-3/16 x 12 Ga.
25	532 12 70-18	Bolt Shoulder 5/16-18 x .62

**NOTE:** All component dimensions given in U.S. inches.  
1 inch = 25.4 mm



# REPAIR PARTS

TRACTOR- -MODEL NO. BM135B92RB (96061020502), PRODUCT NO. 960 61 02-05  
DECALS

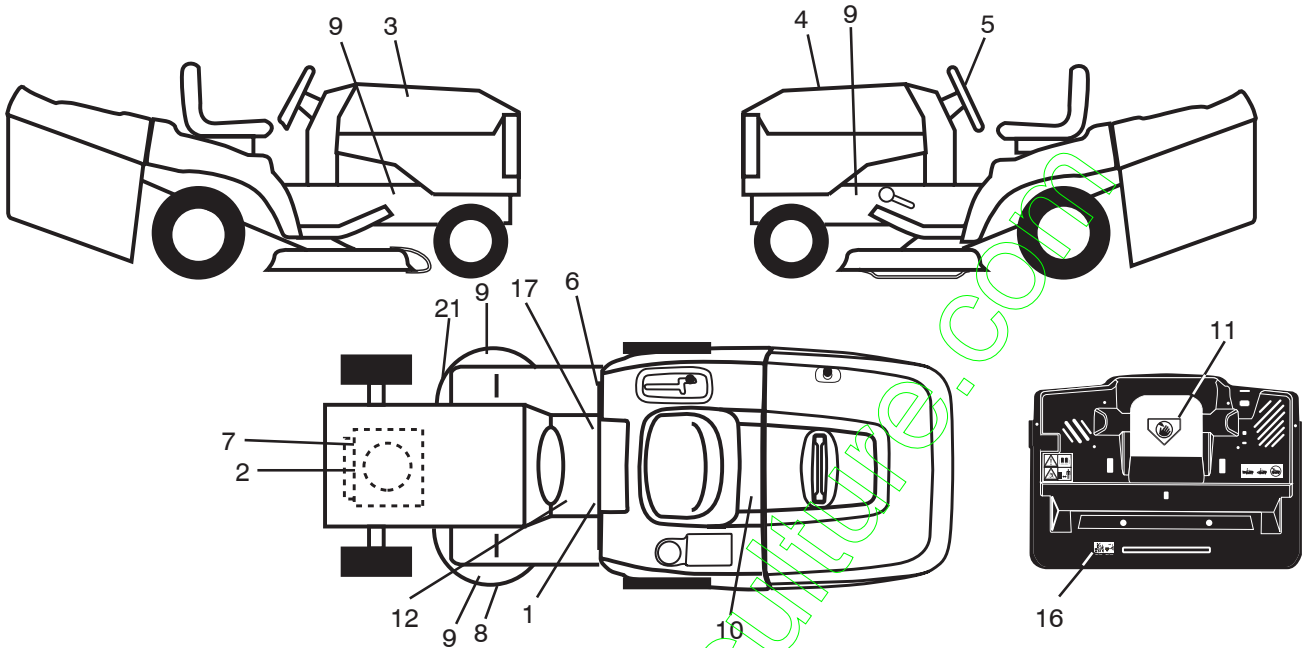

KEY NO.	PART NO.	DESCRIPTION	KEY NO.	PART NO.	DESCRIPTION
1	532 40 03-89	Decal Warning Symbols CE	12	532 15 97-37	Decal Brake/Clutch Symbol Lt
2	532 40 88-15	Decal Hp Engine	14	532 15 97-36	Decal Chassis Hot Muffler
3	532 40 84-81	Decal Hood LH	16	532 18 04-35	Decal Backplate
4	532 40 84-82	Decal Hood RH	17	532 14 08-37	Decal Saddle Brake Parking
5	532 19 44-19	Decal Wheel Steering	21	532 16 62-86	Decal Hex Belt Sch 92 CRD
6	532 18 04-32	Decal 100 DBA/CE	--	532 13 83-11	Decal Lift Handle
7	532 19 68-41	Decal Warning Eng Sym	--	532 18 10-90	Pad Footrest RH
8	532 18 78-11	Decal Deck Enviro	--	532 18 10-91	Pad Footrest LH
9	532 19 68-42	Decal SDL SHF/CRD Sum Cutfinger	--	532 41 65-76	Manual Operator's (Euro)
10	532 14 50-05	Decal Bat Dan/Poi P/L Sym Wpn	--	<b>532 41 84-37</b>	Manual Parts
11	532 18 21-66	Decal Mower Cut Finger Symbol			

## WHEELS & TIRES

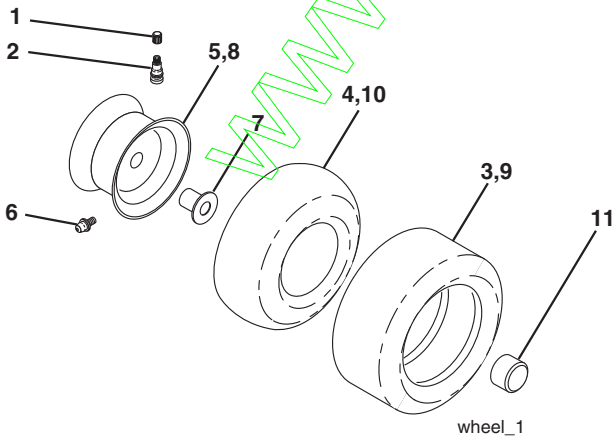

KEY NO.	PART NO.	DESCRIPTION
1	532 05 91-92	Cap Valve Tire
2	532 06 51-39	Stem Valve
3	532 10 62-22	Tire F Ts 15 x 6 0-6
4	532 05 99-04	Tube Inner Front #35060
5	532 13 83-36	Rim Asm 6" Front
6	532 12 49-57	Fitting Grease
7	532 12 49-59	Bearing Flange
8	532 13 83-37	Rim Asm 8" Rear
9	532 10 62-68	Tire R Ts 18 x 5-8 Turf Saver
--	532 42 05-31	Tire R Ts 18 x 5-8 Turf Saver LT
10	532 12 49-26	Tube Rear 9 5 x 8
11	532 17 50-39	Cap Axle Blk 1 50 x 1 00
--	532 14 43-34	Sealant, Tire (10 oz. tube)

**NOTE:** All component dimensions given in U.S. inches  
1 inch = 25.4 mm

# REPAIR PARTS

TRACTOR- -MODEL NO. BM135B92RB (96061020502), PRODUCT NO. 960 61 02-05  
MOWER LIFT

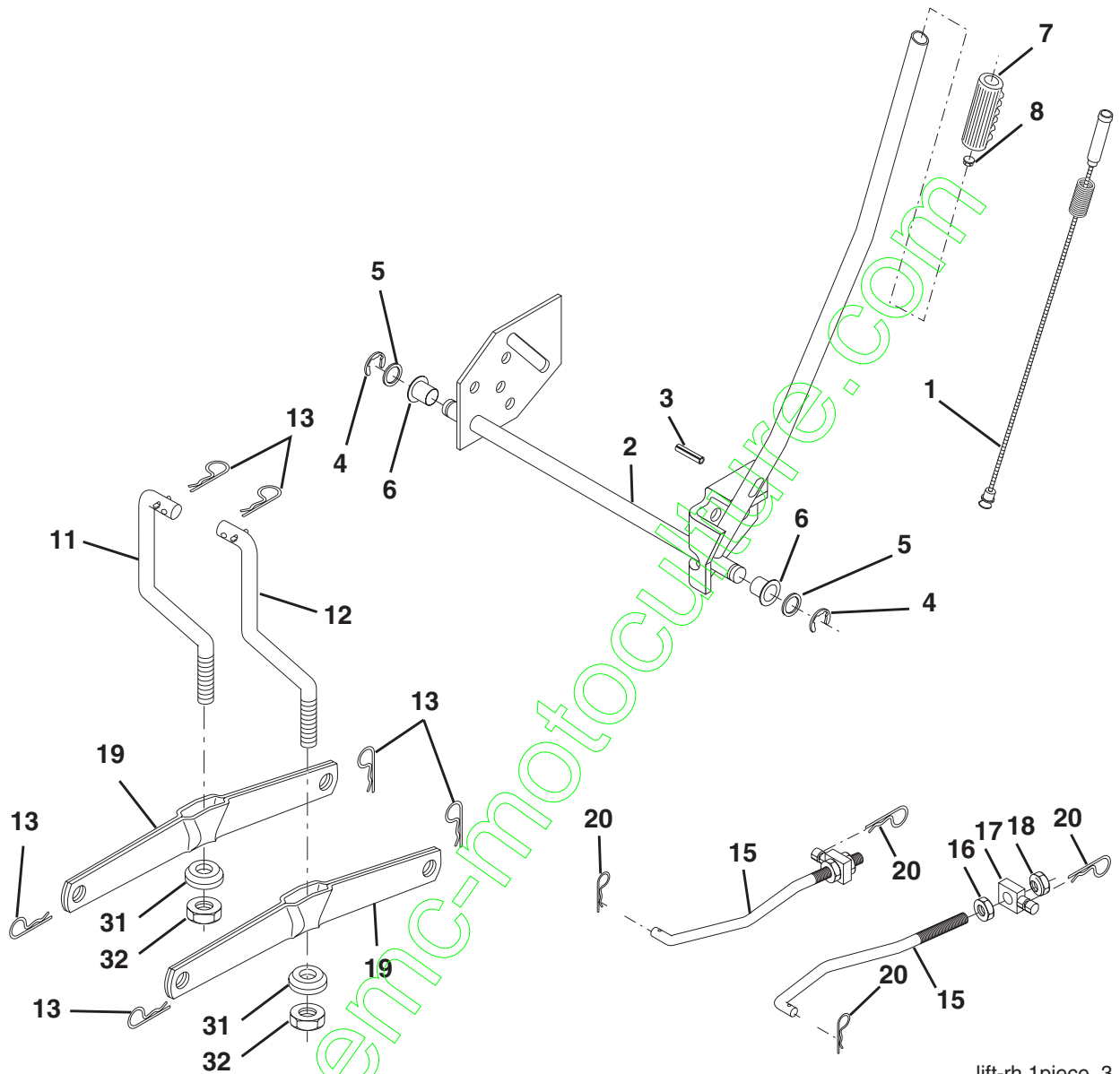

lift-rh.1piece\_3

KEY NO.	PART NO.	DESCRIPTION
1	532 19 84-17	Wire Asm Inner Spring w/Plunger
2	532 19 80-70	Shaft Asm. Lift
3	532 18 88-22	Pin Groove
4	812 00 00-02	E-Ring #5133-62
5	819 21 16-21	Washer 21/32 x 1 x 21 Ga.
6	532 12 01-83	Bearing Nylon
7	532 10 94-13	Grip Handle
8	532 12 45-26	Button Plunger Black
11	532 16 58-29	Link Asm Lift LH
12	532 16 58-31	Link Asm Lift RH
13	532 12 46-70	Retainer Spring

KEY NO.	PART NO.	DESCRIPTION
15	532 17 32-88	Link Front
16	873 35 08-00	Nut Jam Hex 1/2-13 unc
17	532 17 56-89	Trunnion Blk Zinc
18	873 80 08-00	Nut Lock w/Wsh 1/2-13 unc
19	532 13 98-68	Arm Suspension Mower
20	532 19 42-09	Retainer Spring
31	532 16 98-65	Bearing, Pvt. Lift.
32	873 54 06-00	Nut Crownlock 3/8-24

**NOTE:** All component dimensions given in U.S. inches  
1 inch = 25.4 mm

# REPAIR PARTS

TRACTOR- -MODEL NO. BM135B92RB (96061020502), PRODUCT NO. 960 61 02-05  
BAGGER

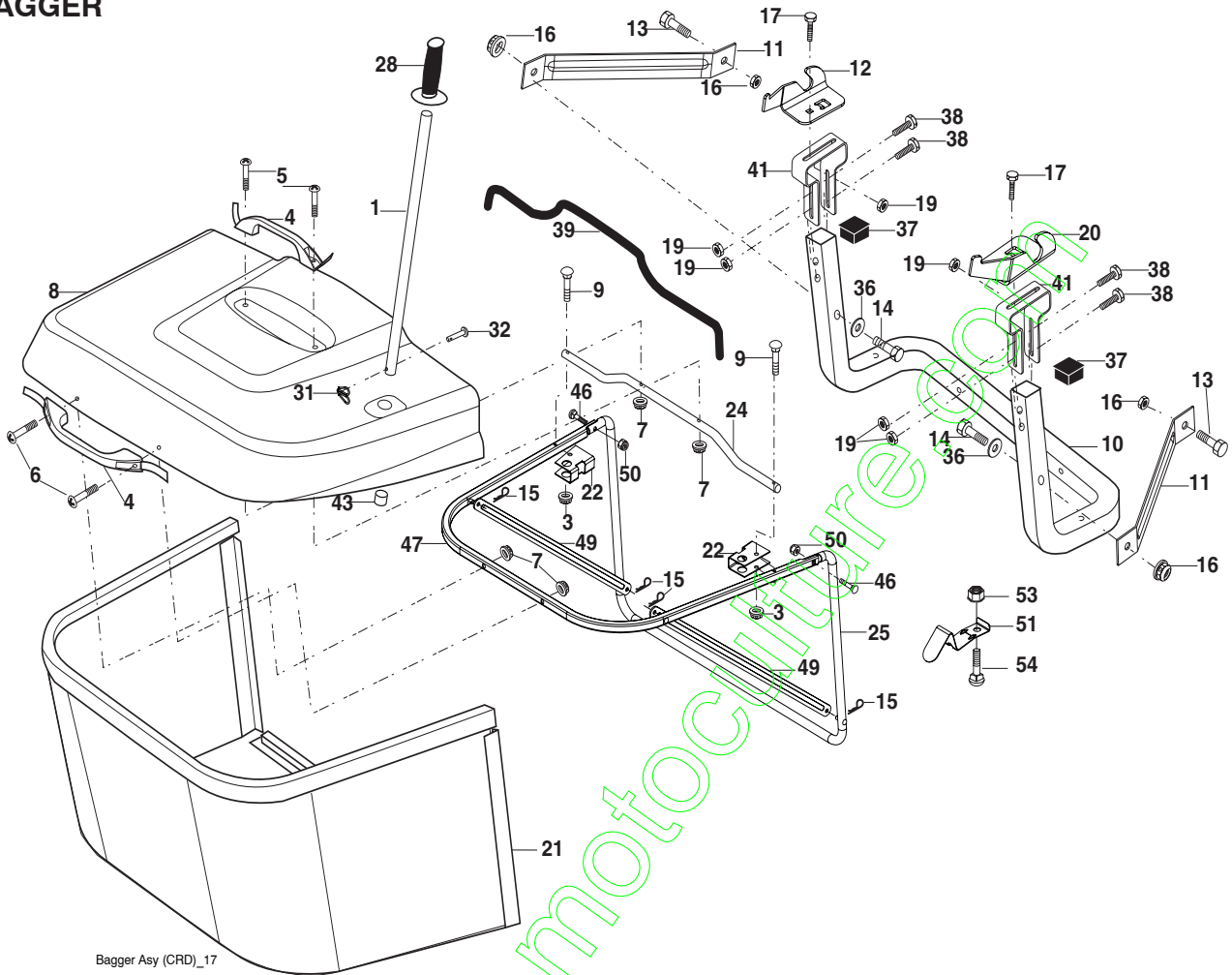

Bagger Asy (CRD)\_17

KEY NO.	PART NO.	DESCRIPTION	KEY NO.	PART NO.	DESCRIPTION
1	532 16 52-49	Tube Handle Bagger CRD	24	532 16 57-83	Tube Pivot Bagger CRD
3	532 12 39-76	Nut Lock 1/4 Lge Flg Gr. 5 Zinc	25	532 19 37-05	Tube Front Bagger CRD
4	532 16 99-16	Handle Bagger w/Lvrs Blk CRD	28	532 16 57-87	Grip Handle Black
5	874 98 10-24	Screw Pan Head #10-24 x 1.50 Blk	31	532 16 94-84	Retainer Clip
6	874 98 10-32	Screw Pan Hd	32	532 12 68-75	Rivet Rd Hd Drilled 3/8 Dia
7	873 40 10-00	Nut Wiz Lock Hex Serr/Hd 10-24	36	819 13 20-12	Washer 13/32 x 1-1/4 x 12 Ga.
8	532 19 24-70	Cover Bagger	37	532 17 54-01	Plug Support Bagger CRD
9	872 14 04-18	Bolt Carriage 1/4-20 x 2.25 d x Gr. 5	38	872 01 05-20	Bolt 5/16-18 x 2-1/2
10	532 18 12-82	Tube Support Bagger CRD	39	532 18 09-85	Seal Trim
11	532 16 57-19	Bracket Support Upper Bag CRD	41	532 16 96-83	Bracket Pnt Adj Pvt Bagger CRD
12	532 18 88-48	Bracket Pivot LH	43	532 17 40-83	Plug Tubing End
13	874 76 06-12	Bolt Fin Hex 3/8-16 unc x 3/4	46	872 11 05-10	Bolt Carr. 5/16-18 x 1-1/4 Gr. 5
14	874 52 06-36	Bolt Fin Hex 3/8-16 x 2-1/4 Gr. 5	47	532 19 37-04	Tub Upper Bagger
15	532 12 46-70	Retainer Spring	49	532 19 33-05	Bar Spreader
16	873 90 06-00	Nut Lock Flg.	50	873 80 05-00	Nut Lock Hex w/INC 5/16-18 unc
17	872 14 05-06	Bolt Rdhd Sht Sqnk 5/16 -18 unc x 3/4	51	532 19 99-03	Latch Spring Bagger
19	873 90 05-00	Nut Lock Hex Flange 5/16-18	54	872 14 04-06	Bolt RHHD SQNK 1/4-20 x 3/4 Gr. 5
20	532 18 88-47	Bracket Pivot RH	53	873 51 04-00	Nut Keps Hex 1/4-20 unc
21	532 40 61-80	Bag Asm CRD			
22	532 16 57-81	Bracket Side Bagger CRD			

**NOTE:** All component dimensions given in U.S. inches  
1 inch = 25.4 mm

[www.emc-motoculture.com](http://www.emc-motoculture.com)

**BESTGREEN**