

**REPAIR PARTS MANUAL**  
**MODEL NO. BM155H107RBK (96061010602)**  
**Lawn Tractor**

---

***BESTGREEN***

# HOW TO USE THIS MANUAL

This manual is designed to provide the customer with a means to identify the parts on his/her tractor when ordering repair parts. The illustrations may or may not represent the actual assemblies; therefore, it is not recommended to use this manual as a guide to assemble or disassemble the tractor. Some hardware and parts are drawn larger in order to more readily identify them.

Each tractor has its own model number.

The model number for your tractor can be found on the fender under the seat.

When ordering parts, always give the following information:

- Product - "Tractor"
- Model Number - "BM155H107RBK (96061010602)"
- Part Number
- Part Description

## TABLE OF CONTENTS

SCHEMATIC .....	3
ELECTRICAL.....	4-5
CHASSIS .....	6-7
DRIVE.....	8-9
STEERING .....	10-11
SEAT .....	12
DECALS.....	13
ENGINE.....	14-15
MOWER DECK .....	16-17
BAGGER.....	18
MOWER LIFT.....	19

# TRACTOR- -MODEL NO. BM155H107RBK (96061010602), PRODUCT NO. 960 61 01-06 SCHEMATIC

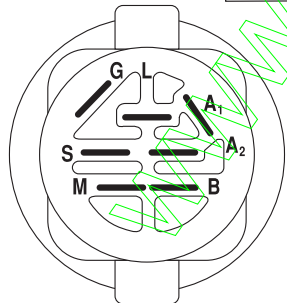
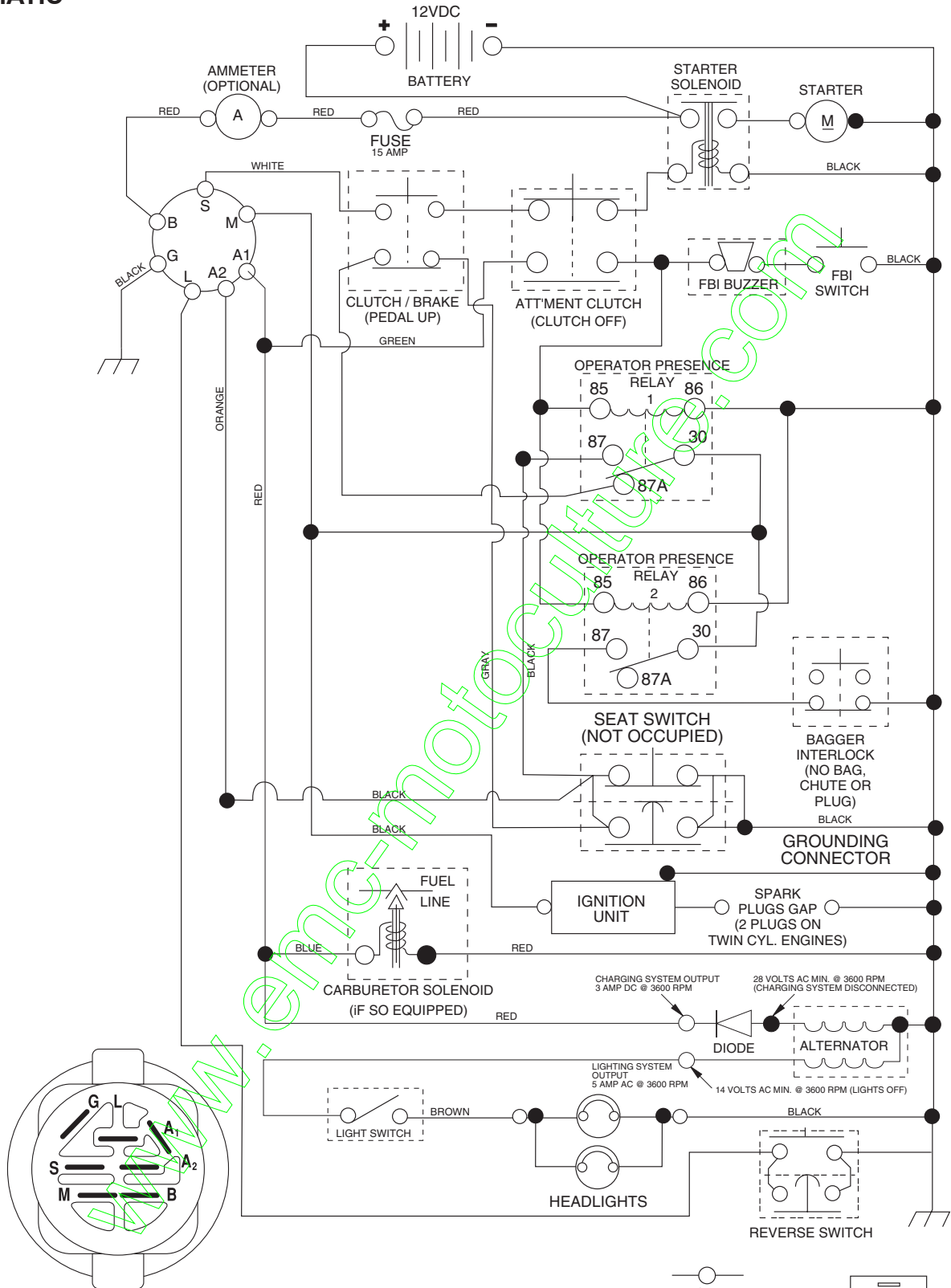

**IGNITION SWITCH**

POSITION	CIRCUIT "MAKE"
OFF	M+G+A1
RUN/OVERRIDE	B+A1
RUN	B+A1 L+A2
START	B + S + A1

**WIRING INSULATED CLIPS**  
**NOTE: IF WIRING INSULATED CLIPS WERE REMOVED FOR SERVICING OF UNIT, THEY SHOULD BE REPLACED TO PROPERLY SECURE YOUR WIRING.**

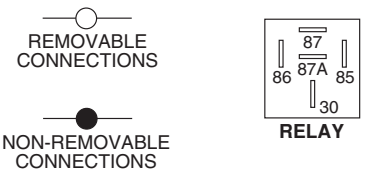

03055

# REPAIR PARTS

TRACTOR- -MODEL NO. BM155H107RBK (96061010602), PRODUCT NO. 960 61 01-06  
ELECTRICAL

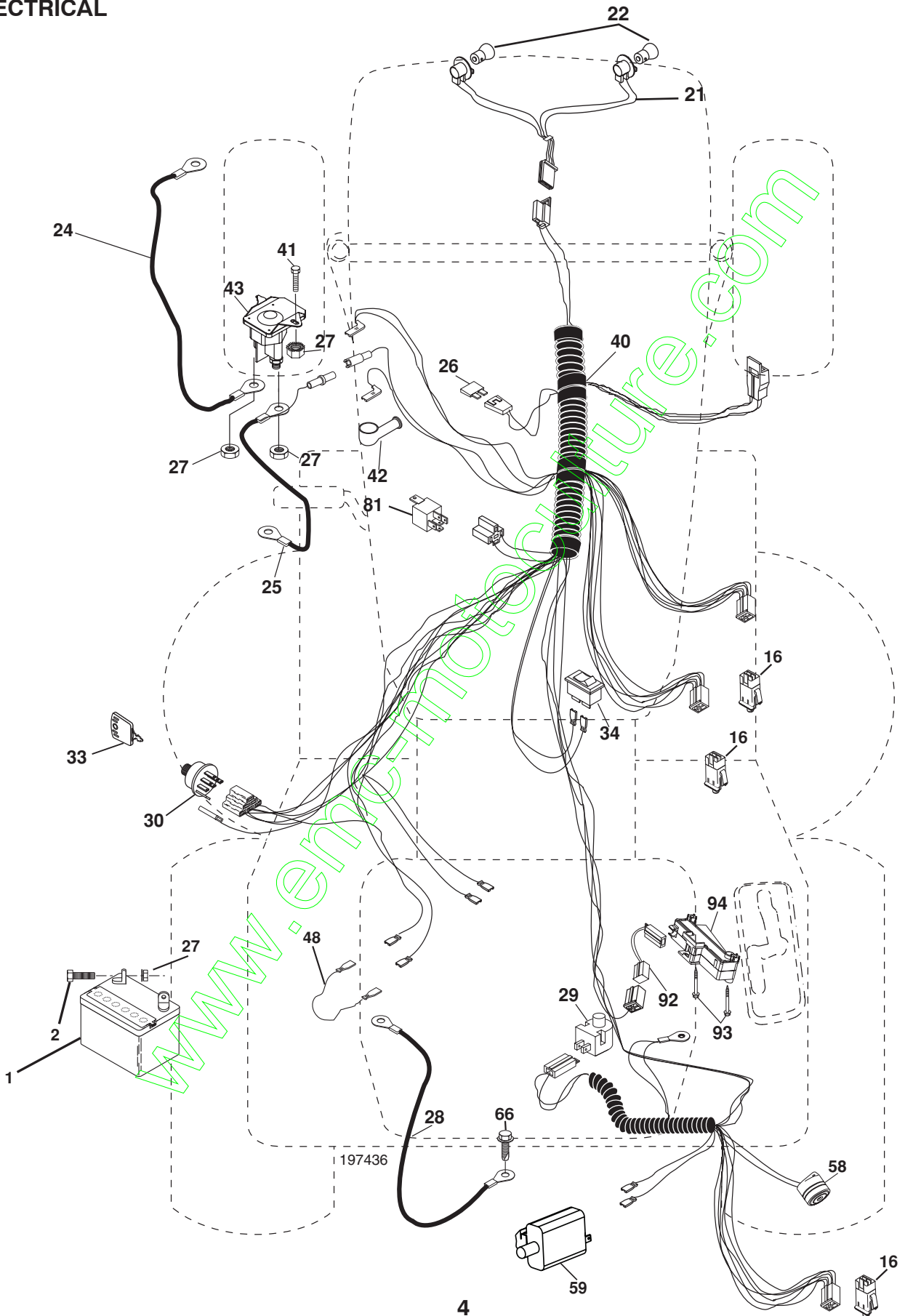

# REPAIR PARTS

TRACTOR- -MODEL NO. BM155H107RBK (96061010602), PRODUCT NO. 960 61 01-06  
ELECTRICAL

KEY NO.	PART NO.	DESCRIPTION
1	532 16 34-65	Battery
2	874 76 04-12	Bolt Hex Hd 1/4-20 unc x 3/4
16	532 17 61-38	Switch Interlock
21	532 18 37-59	Harness Asm Light W/4152J
22	532 00 41-52	Bulb Light #1156
24	532 12 47-80	Cable Starter 6 Ga. 11" Red
25	532 16 59-87	Cable Battery Crd 56" Red
26	532 17 51-58	Fuse
27	873 51 04-00	Nut Keps Hex 1/4-20 unc
28	532 12 77-25	Cable Ground 6 Ga. 18" Black
29	532 19 27-49	Switch Seat
30	532 19 33-50	Switch Ignition
33	532 14 04-01	Key Ign
34	532 11 07-12	Switch Light
40	532 19 74-36	Harness Ign
41	871 11 04-08	Bolt Flk Fin Hex 1/4-20 unc x 1/2
42	532 13 15-63	Cover Terminal Red
43	532 19 25-07	Solenoid
48	532 14 08-44	Adapter Ammeter Rectangular
58	532 16 94-19	Buzzer Crd
59	532 18 03-79	Switch FBI CRD
66	817 49 06-08	Screw Thdrol 3/8-16 x 1/2 Ty-Tt
81	532 10 97-48	Relay Asm
92	532 19 66-15	Harness Pigtail
93	532 19 25-40	Screw Plastite 10-44 x 2.0
94	532 19 18-34	Module Reverse

**NOTE:** All component dimensions given in U.S. inches.  
1 inch = 25.4 mm.

# REPAIR PARTS

TRACTOR - MODEL NO. BM155H107RBK (96061010602), PRODUCT NO. 960 61 01-06  
CHASSIS AND ENCLOSURES

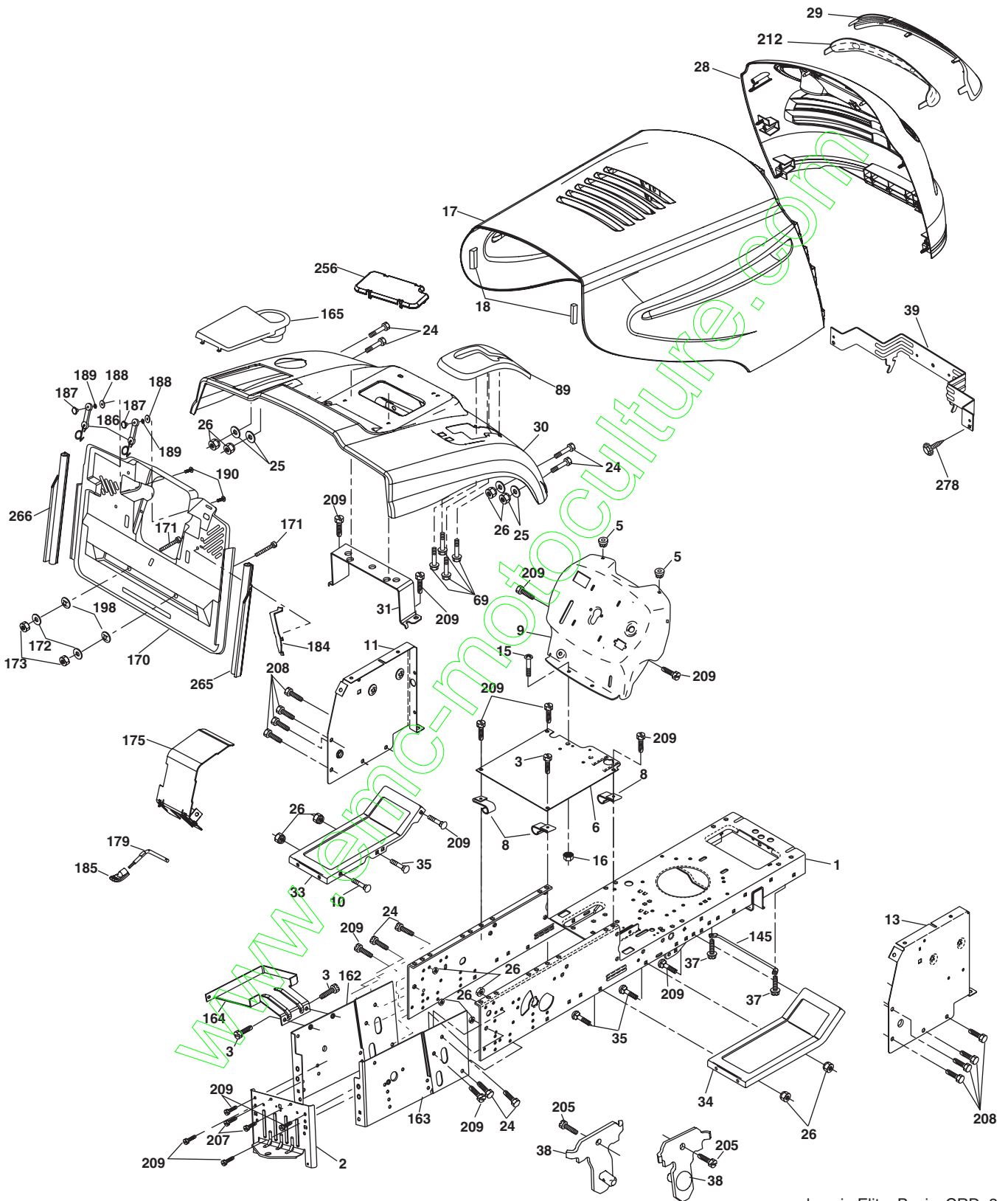

chassis-Elite\_Basic\_CRD\_3

# REPAIR PARTS

TRACTOR- -MODEL NO. BM155H107RBK (96061010602), PRODUCT NO. 960 61 01-06  
CHASSIS AND ENCLOSURES

KEY NO.	PART NO.	DESCRIPTION	KEY NO.	PART NO.	DESCRIPTION
1	532 17 46-20	Chassis	162	532 18 03-82	Bracket Exten Chassis Lh CRD
2	532 18 03-84	Drawbar	163	532 18 03-83	Bracket Exten Chassis Rh CRD
3	817 06 06-12	Screw 3/8-16 x .75	164	532 16 56-05	Support Battery CRD
5	532 15 52-72	Bumper Hood/Dash	165	532 18 13-56	Cover Battery CRD
6	532 18 44-19	Saddle	170	532 19 94-88	Backplate CRD
8	532 12 64-71	Clip Insulator 13/32 Mtg. Hole	171	872 14 06-20	Bolt Rdhd Sank 3/8-16 x 2-1/2 G5
9	532 19 46-88	Dash	172	819 13 20-16	Washer 13/32 x 1-1/4 x 16 Ga.
10	872 14 06-08	Bolt, Carriage 3/8-16 x 3/4	173	873 51 06-00	Nut, Keps Hex 3/8-16 unc
11	532 17 49-96	Panel, Dash, L.H.	175	532 18 82-03	Trap Door CRD
13	532 18 69-52	Panel, Asm. Dash R.H.	179	532 18 82-02	Rod Pivot FBI CRD
15	874 18 05-12	Screw, Machine, Truss Head 5/16-18 unc x 3/4	184	532 17 46-62	Bracket Actuator Bagger CRD
16	873 51 05-00	Nut	185	532 18 11-01	Knob Rod
17	532 19 24-37	Hood Assembly	186	532 16 07-93	Latch Asm Multch Bagger
18	532 18 49-21	Bumper Hood	187	532 12 50-04	Nut Weld .327/.304 #10-24
24	874 78 06-16	Bolt	188	819 06 12-16	Washer #10
25	819 13 13-12	Washer 13/32 x 13/16 x 12 Ga.	189	810 07 10-00	Washer Lock #10
26	873 80 06-00	Nut	190	871 08 10-10	Screw Pan Hd Phillips 10-24 x 5/8
28	532 18 38-26	Grille Lens Asm (Includes Key #'s 29, 212)	198	532 16 89-37	Nut Push
29	532 18 98-37	Lens Grille	205	817 49 06-08	Screw 3/8-16 x 1/2
30	532 19 73-56	Fender	207	817 67 05-08	Screw 5/16-18 x 1/2
31	532 16 51-56	Bracket, Fender Support	208	817 67 06-08	Screw Thdrol 3/8-16 x 1/2
33	532 18 64-57	Footrest, L.H.	209	817 00 06-12	Screw Hex Wsh Thdrol 3/8-16 x 3/4
34	532 18 64-58	Footrest, R.H.	212	532 18 38-23	Insert Lens
35	872 11 06-06	Bolt	256	532 18 13-61	Cover Fender Rack CRD
37	817 49 05-08	Screw Thdrol 5/16-18 x 1/2 TYT	265	532 18 57-04	Seal, Side RH
38	532 18 17-48	Bracket Asm Pivot Mower Rear	266	532 18 57-03	Seal, Side LH
39	532 17 47-14	Bracket Pivot	278	532 19 16-11	Screw 10 x 3/4 Single Lead Hex
69	532 14 24-32	Screw Hex 1/4-1/2	--	532 00 54-79	Plug, Button
89	532 19 73-66	Console			
145	532 15 65-24	Rod Pivot Chassis/Hood			

**NOTE:** All component dimensions given in U.S. inches.  
1 inch = 25.4 mm.





# REPAIR PARTS

TRACTOR- -MODEL NO. BM155H107RBK (96061010602), PRODUCT NO. 960 61 01-06  
DRIVE

KEY NO.	PART NO.	DESCRIPTION	KEY NO.	PART NO.	DESCRIPTION
1	-----	Transaxle Hydro Gear 321-0510 (Order parts from transaxle manufacturer)	112	819 09 12-10	Washer 9/32 x 3/4 x 10 Ga.
8	532 19 27-06	Rod, Shift Fender Adjust Lt	120	873 90 06-00	Nut Lock Flg. 3/8-16 unc
9	532 19 81-44	Clutch Asm Noram	150	532 16 58-50	Bushing, Bellcrank Grnd Dr
10	876 02 04-16	Pin, Cotter 1/8 x 1	151	819 13 32-10	Washer 13/32 x 2 x 10 Ga.
14	810 04 04-00	Washer, Lock Hvy Helical	156	532 16 60-02	Washer Strtd 5/16 ID x 1.125
15	874 49 05-44	Bolt Hex FGHD 5/16-18 x Gr 5	158	532 16 55-89	Bracket Shift Mount
16	873 80 05-00	Nut Lock Hex W/Ins 5/16-18 unc	159	532 18 39-00	Hub Shift
19	873 80 06-00	Nut Lock Hex w/Ins 3/8-16 unc	161	872 14 04-06	Bolt Rdhd Sqnk 1/4-20 x 3/4 Gr 5
21	532 10 69-33	Knob	162	873 68 04-00	Nut Crownlock 1/4-20 unc
22	532 17 56-07	Nut	163	874 78 04-16	Bolt Hex Fin 1/4-20 unc x 1 Gr 5
24	873 35 06-00	Nut Hex Jam 3/8-16 unc	165	532 16 56-23	Bracket Pivot Lever
25	532 19 20-36	Spring, Rod, Brake	166	817 49 05-10	Screw 5/16-18 x 5/8
27	876 02 04-12	Pin, Cotter 1/8 x 3/4	167	532 16 55-88	Bracket Support Shift CRD
28	532 17 57-65	Rod, Parking Brake	168	532 16 54-92	Bolt Shoulder 5/16-18 x .561
29	532 07 16-73	Cap, Parking Brake	169	532 16 55-80	Plate Fastening Lt
30	532 16 95-92	Bracket, Mfg. Transaxle	171	817 49 06-08	Screw Thdrol 3/8-16 x 1/2 Ty-Tt
34	532 17 55-78	Shaft, Asm Pedal Foot CRD	172	532 17 02-71	Shaft Asm Shifter Frt CRD
35	532 12 01-83	Bearing, Nylon	177	532 16 59-32	Keeper Flat Idler 3.06" CRD
36	819 21 16-16	Washer 21/32 x 1 x 16 Ga.	181	532 18 02-11	Bracket Idler Ground Drive CRD
37	532 12 49-63	Pin, Roll 3/16 x 1"	182	532 18 26-82	Keeper Belt 2.5" Od V-Idler CRD
38	532 13 14-94	Pulley Flat Composite 3.06"	183	532 18 60-07	Pulley V-Idler 2.50" Od CRD
39	874 76 06-44	Bolt Fin Hex 3/8-16 unc x 2-3/4	185	532 17 00-08	Link Shift
40	532 12 49-65	Spacer, Split 395 x 59 Bzp	186	532 16 56-14	Hub Tapered Round CRD
42	819 13 13-12	Washer 13/32 x 13/16 x 12 Ga.	187	817 58 05-20	Screw Thdrol 5/16-18 x 1.25
43	819 11 10-12	Washer 11/32 x 5/8 x 12 Ga.	197	532 16 96-13	Nyliner Snap-In 5/8
47	532 12 77-83	Pulley, Idler, V Groove Plastic	199	532 16 96-12	Bolt Shoulder 5/16-18 unc
48	532 15 44-07	Bellcrank Clutch Grnd Drv	200	872 14 05-08	Bolt RDHD SQNK 5/16-18 x 1
49	532 12 32-05	Retainer, Belt Style Spring	203	871 17 07-80	Bolt Hex 7/16-20 x 5
50	872 11 06-12	Bolt Carr. Sh. 3/8-16 x 1-1/2 Gr. 5	207	532 16 98-45	Washer Nylon Rear
51	873 68 06-00	Nut, Crownlock 3/8-16 unc	214	532 17 56-09	Shaft Asm. Brake
52	873 68 05-00	Nut Crownlock 5/16-18	215	532 17 56-52	Rod Brake Hydro
53	532 19 96-52	Link, Clutch 7.66	252	819 13 16-16	Washer 13/32 x 1 x 16 Ga.
55	532 10 57-09	Spring, Return, Clutch	253	532 17 50-28	Bracket Cable Chassis
56	817 06 06-20	Screw 3/8-16 x 1-1/4	254	817 00 06-16	Screw 3/8-16 x 1
57	532 17 01-40	V-Belt Kev 112" 0650 CRD	255	532 17 56-08	Brace Shaft Brake Mtg.
62	532 12 48-72	Cover, Pedal	258	532 17 80-62	Clip Retainer
65	810 04 07-00	Washer	259	532 18 02-12	Bracket Pulley
66	532 15 47-78	Keeper, Belt Engine F-Proof	261	532 13 14-94	Pulley Idler
71	532 16 91-83	Strap, Torque, Lh	262	872 11 06-22	Bolt Carr. 3/8-16 x 2-3/4 Gr.5
73	532 16 91-82	Strap, Torque, Rh	263	817 00 06-12	Screw 3/8-16 x 3/4
74	532 13 70-57	Spacer, Split	264	532 19 76-08	Bracket Idler Chassis
75	532 12 17-49	Washer 25/32 x 1-1/4 x 16 Ga.	265	532 18 20-13	Spacer Idler Chassis
76	812 00 00-01	Ring, E	266	532 18 20-61	Shield Idler Mower
77	532 12 35-83	Key, Square	268	532 18 24-02	Guard Muffler RH
78	532 12 17-48	Washer 25/32 x 1-5/8 x 16 Ga.	275	819 13 16-14	Washer 13/32 x 1 x 14 Ga.
81	532 17 00-06	Asm, Shaft, Cross Rear	293	872 14 06-28	Bolt 3/8-16 x 3-1/2
82	532 16 57-11	Spring, Torsion	294	532 19 70-33	Nut 3/8-16
83	819 17 12-16	Washer 17/32 x 3/4 x 16 Ga.	295	532 17 91-14	Pulley Idler Composite
84	532 17 00-07	Link, Transaxle			
95	532 17 00-15	Control Asm Bypass Hydro			
96	532 12 47-88	Spring, Retainer 1"			

**NOTE:** All component dimensions given in U.S. inches  
1 inch = 25.4 mm

# REPAIR PARTS

TRACTOR- -MODEL NO. BM155H107RBK (96061010602), PRODUCT NO. 960 61 01-06  
STEERING ASSEMBLY

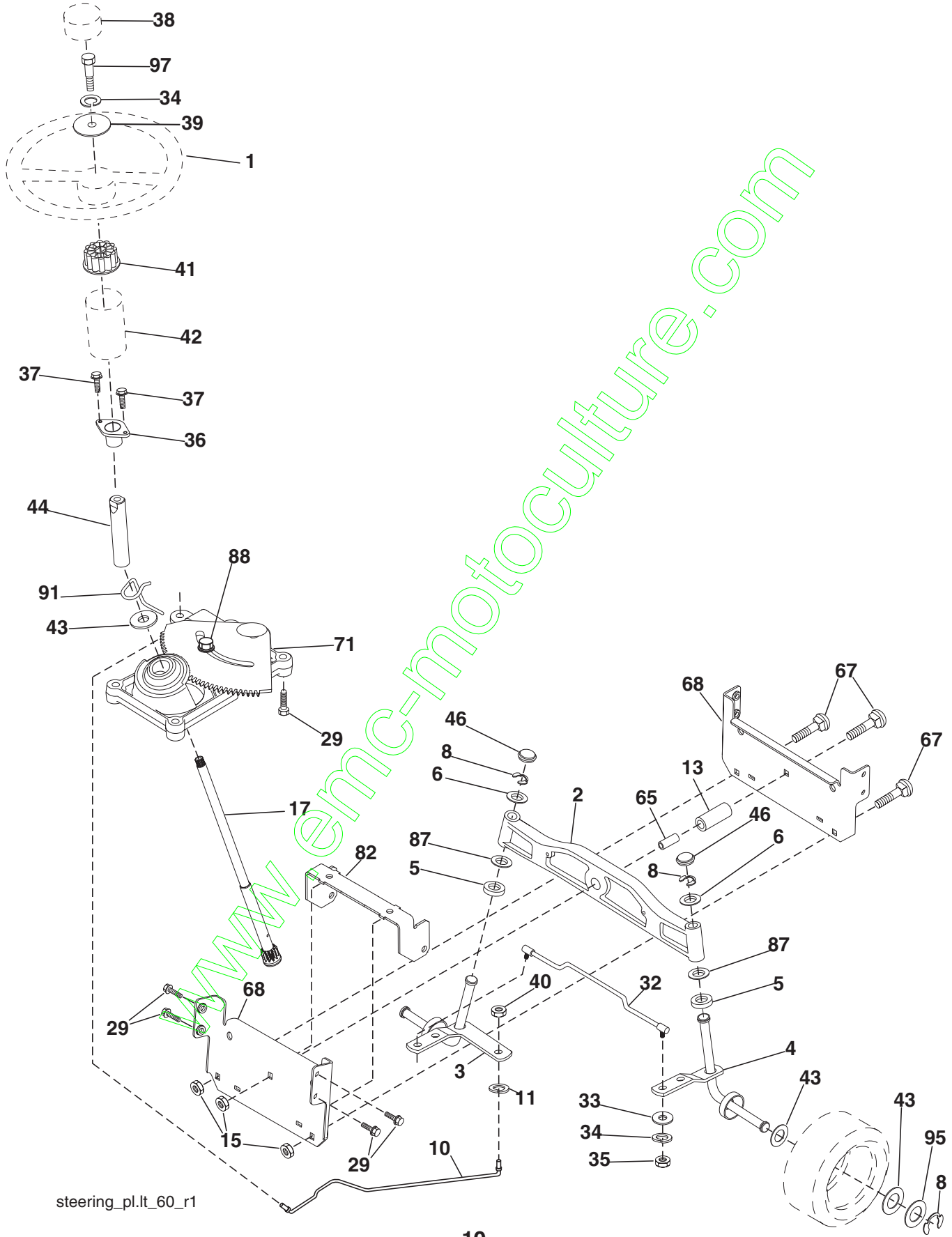

steering\_pl.lt\_60\_r1

# REPAIR PARTS

TRACTOR- -MODEL NO. BM155H107RBK (96061010602), PRODUCT NO. 960 61 01-06  
STEERING ASSEMBLY

KEY NO.	PART NO.	DESCRIPTION
1	532 19 45-95	Steering Wheel
2	532 18 47-06	Front Axle Assembly
3	532 16 98-40	Spindle Assembly, L.H.
4	532 16 98-39	Spindle Assembly, R.H.
5	532 12 49-31	Bearing, Race, Thrust, Hardened
6	532 12 17-48	Washer 25/32 x 1-5/8 x 16 Ga.
8	812 00 00-29	Ring, Klip
10	532 17 51-21	Link, Drag
11	810 04 06-00	Washer, Lock
13	532 13 65-18	Spacer Axle
15	532 14 52-12	Nut Hex Flange Lock
17	532 19 07-53	Shaft Assembly, Steering
29	817 00 06-12	Screw 3/8-16 x 3/4
32	532 17 01-62	Rod, Tie
33	819 11 12-16	Washer 11/32 x 3/4 x 16 Ga.
34	810 04 05-00	Washer Lock Hvy Hlcl Spr 5/16
35	873 54 05-00	Crownlock Nut 5/16-24 unf
36	532 15 50-99	Bushing, Steering
37	532 15 29-27	Screw TT #10-32 x 5 x 3/8 Flange
38	532 19 46-03	Cap Wheel Steering
39	819 11 38-12	Washer 11/32 ID x 2-3/8 OD x 12 Ga.
40	873 54 06-00	Nut Crownlock 3/8-24
41	532 18 67-37	Adaptor, Steering Wheel
42	532 16 96-33	Boot, Steering Dash P/L Mtl
43	532 12 17-49	Washer 25/32 x 1-1/4 x 16 Ga.
44	532 19 07-52	Extension Steering
46	532 12 12-32	Cap, Spindle
65	532 16 03-67	Spacer Axle
67	872 11 06-18	Bolt Rdhd Sq 3/8-16 x 2-1/4
68	532 16 98-27	Brace Axle
71	532 17 51-46	Steering Asm.
82	532 19 99-78	Bracket Susp. Chassis Front
87	532 17 39-66	Washer Flat .781 x 1-1/2 x .14
88	532 17 51-18	Bolt Shoulder 7/16-20 unc
91	532 17 55-53	Clip Steering
95	532 18 89-67	Washer
97	874 78 05-64	Bolt 5/16-18 unc x 4" L Gr. 5

**NOTE:** All component dimensions given in U.S. inches.  
1 inch = 25.4 mm.

# REPAIR PARTS

TRACTOR- -MODEL NO. BM155H107RBK (96061010602), PRODUCT NO. 960 61 01-06  
SEAT ASSEMBLY

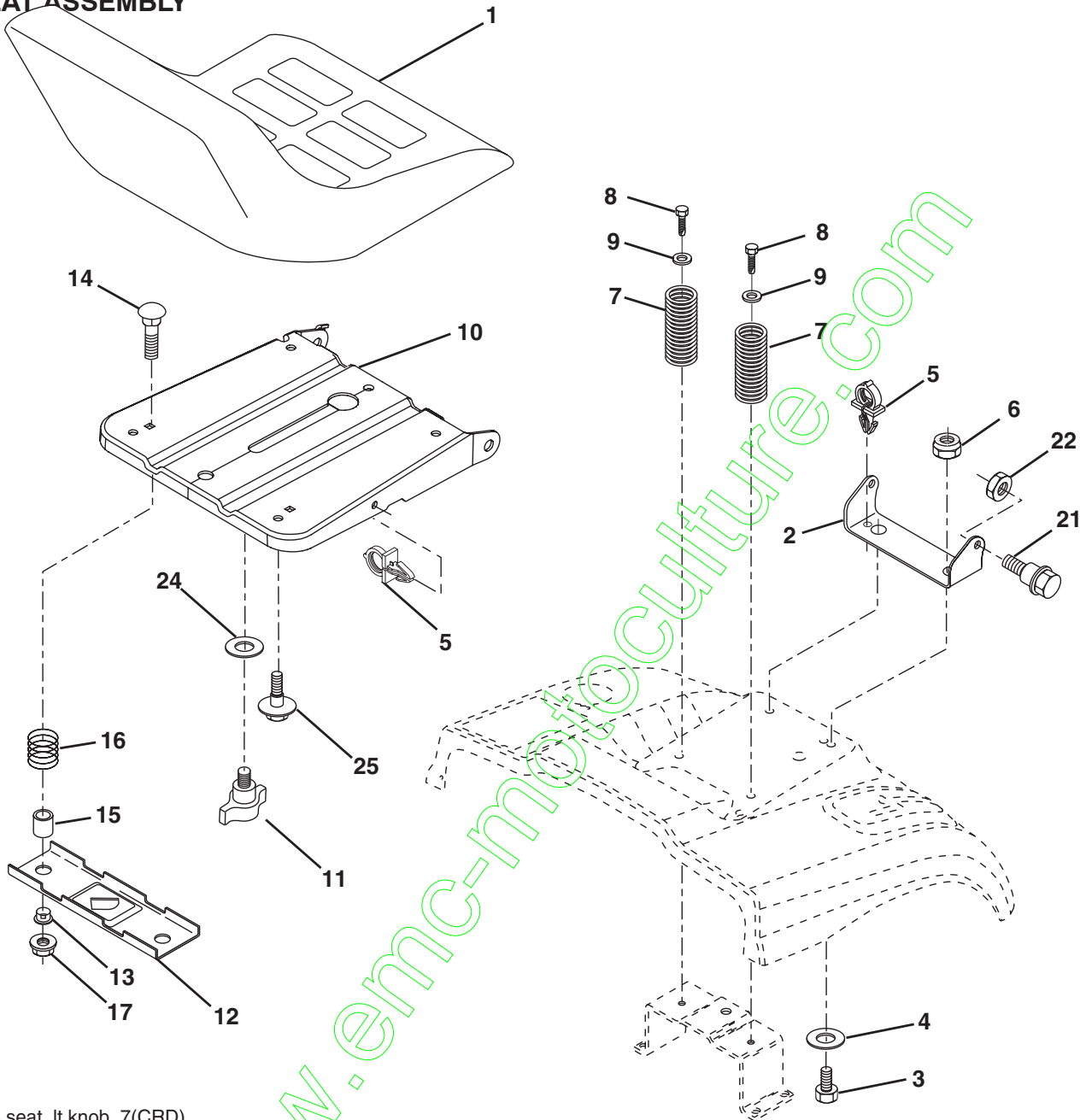

seat\_lt.knob\_7(CRD)

KEY NO.	PART NO.	DESCRIPTION
1	532 40 10-43	Seat
2	532 14 05-51	Bracket Pnt Pivot Seat (blk )
3	871 11 06-16	Bolt Fin Hex 3/8-16 x 1
4	819 13 16-10	Washer Flat 13/32 x 1 x 10 Ga.
5	532 14 50-06	Clip Push In Hinged
6	873 80 06-00	Nut Lock Hex W/Ins 3/8-16
7	532 12 41-81	Spring Seat Cprsn 2 250 Blk Zi
8	817 00 06-16	Screw 3/8-16 x 1.5
9	819 13 16-14	Washer 13/32 x 1 x 14 Ga
10	532 19 55-30	Pan Pnt Seat
11	532 16 63-69	Knob Seat Adj. Wingnut
12	532 17 46-48	Bracket Pnt Mounting Switch

KEY NO.	PART NO.	DESCRIPTION
13	532 12 12-48	Bushing Snap Blk Nyl 50 Id
14	872 05 04-12	Bolt Rdhd Sht Nk 1/4-20 x 1-1/2
15	532 12 12-49	Spacer Split
16	532 12 37-40	Spring Cprsn
17	532 12 39-76	Nut Lock 1/4 Lge Flg Gr. 5 Zinc
21	532 17 18-52	Bolt Shoulder 5/16-18 unc-2A
22	873 80 05-00	Nut Hex Lock w/Ins 5/16-18
24	819 17 19-12	Washer 17/32 x 1-3/16 x 12 Ga.
25	532 12 70-18	Bolt Shoulder 5/16-18 x 62

**NOTE:** All component dimensions given in U.S. inches.  
1 inch = 25.4 mm

# REPAIR PARTS

TRACTOR- -MODEL NO. BM155H107RBK (96061010602), PRODUCT NO. 960 61 01-06  
DECALS

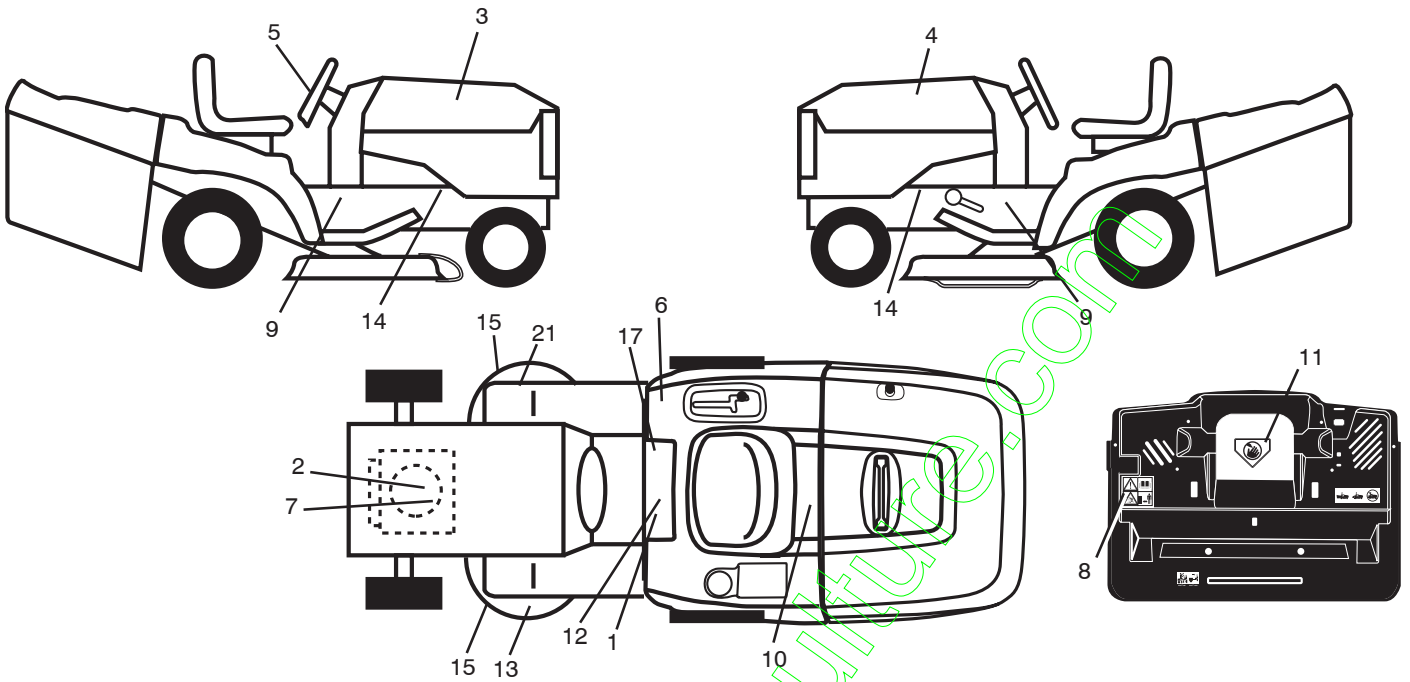

KEY NO.	PART NO.	DESCRIPTION
1	532 40 03-89	Decal Warning Sym CE
2	532 40 88-17	Decal Engine
3	532 40 89-22	Decal Hood RH
4	532 40 89-39	Decal Hood LH
5	532 19 44-19	Decal Steering Wheel
6	532 18 04-32	Decal 100 DBA/CE
7	532 19 68-41	Decal Warning Eng. Sym
8	532 18 04-35	Decal Rear Plate
9	532 40 11-46	Decal Warning Service/Fire
10	532 14 50-05	Decal Bat Dan/Poi P/L (Sym Wpn
11	532 18 21-66	Decal Mower Cut Finger Symbol
12	532 15 97-37	Decal Brake/Clutch Symbol Lt

KEY NO.	PART NO.	DESCRIPTION
13	532 18 78-11	Decal Enviro
14	532 15 97-36	Decal Chassis Hot Muffler
17	532 14 08-37	Decal Saddle Brake Parking
21	532 16 62-86	Decal Hex Belt Sch
--	532 16 69-60	Decal Bypass Fender CRD
--	532 13 83-11	Decal Lift Handle
--	532 18 10-90	Pad Footrest RH
--	532 18 10-91	Pad Footrest LH
--	532 40 89-80	Manual Operator's (Euro)
--	532 40 88-51	Manual Parts

## WHEELS & TIRES

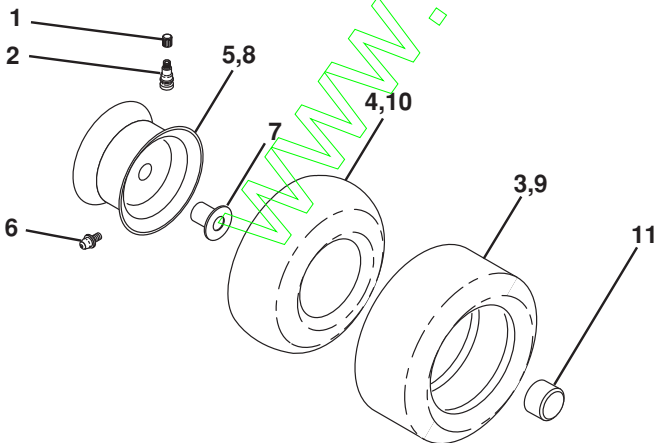

KEY NO.	PART NO.	DESCRIPTION
1	532 05 91-92	Cap Value Tire
2	532 06 51-39	Stem Value
3	532 10 62-22	Tire F Ts 15 x 6 0 - 6 Service
4	532 05 99-04	Tube Inner Front #35060
5	532 13 83-36	Rim Asm 6"front Service
6	532 12 49-57	Fitting Grease
7	532 12 49-59	Bearing Flange
8	532 13 83-37	Rim Asm 8"rear Service
9	532 13 84-68	Tire R Ts 20 x 8-8 Service
10	532 12 49-26	Tube Rear 9 5 x 8 Service
11	532 17 50-39	Cap Axle Blk 1 50 x 1 00
--	532 14 43-34	Sealant, Tire (10 oz. tube)

**NOTE:** All component dimensions given in U.S. inches  
1 inch = 25.4 mm

# REPAIR PARTS

TRACTOR- -MODEL NO. BM155H107RBK (96061010602), PRODUCT NO. 960 61 01-06  
ENGINE

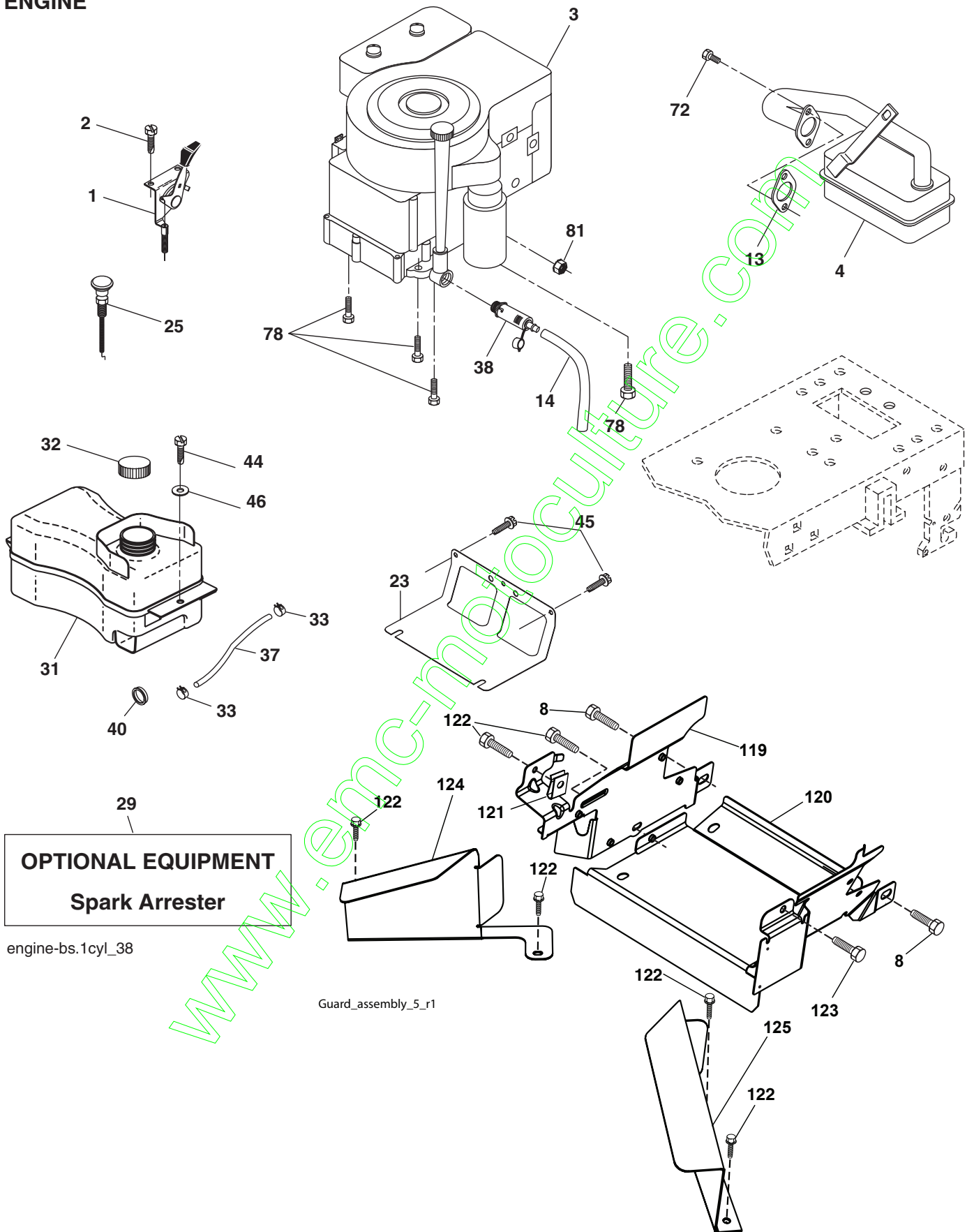

**OPTIONAL EQUIPMENT**  
**Spark Arrester**

engine-bs.1cyl\_38

Guard\_assembly\_5\_r1

# REPAIR PARTS

TRACTOR- -MODEL NO. BM155H107RBK (96061010602), PRODUCT NO. 960 61 01-06  
ENGINE

KEY NO.	PART NO.	DESCRIPTION
1	532 17 05-51	Control Throt Flag
2	817 72 04-08	Screw HEX THD Cut 1/4-20 X 1/2
3	-----	Engine B&S Model 282H070 (Order Parts From Engine Manufacturer)
4	532 13 73-52	Muffler Exhaust
13	532 16 52-91	Gasket Muffler
14	532 14 84-56	Tube Drain Oil Easy
23	532 16 98-37	Shield BRN/DBR Guard
25	532 19 06-95	Control Choke
29	532 13 71-80	Arrestor Spark
31	532 40 75-16	Tank Fuel Front
32	532 19 77-25	Cap Fuel Asm
33	532 12 34-87	Clamp Hose BLK
37	532 13 70-40	Line Fuel
38	532 18 16-54	Plug Drain Oil Easy
40	532 12 40-28	Bushing
44	817 67 04-12	Screw Hexwsh THDROL 1/4-20 X 3/4
45	817 00 06-12	Screw 3/8-16 X 3/4
46	819 09 14-16	Washer 9/32 X 7/8 X 16 Ga.
62	810 01 05-00	Washer Split
72	532 19 23-34	Screw 5/16-18 X .75
78	817 06 06-20	Screw 3/8-1/6 X 1-1/4
81	873 51 04-00	Nut Keps 1/4-20 Unc
8	<b>532 17 18-77</b>	<b>Bolt</b>
119	<b>532 19 97-68</b>	<b>Guard Asm Engine LH CRD</b>
120	<b>532 19 97-67</b>	<b>Guard Asm Engine RH CRD</b>
121	<b>532 19 66-88</b>	<b>Clips Threaded</b>
122	<b>532 13 77-29</b>	<b>Screw THDROL 1/4 - 20 X 5/8</b>
123	<b>817 67 05-08</b>	<b>Screw THDROL 5/16 - 18 X 1/2</b>
124	<b>532 41 05-26</b>	<b>Shield Side LH</b>
125	<b>532 41 05-27</b>	<b>Shield Side RH</b>

**NOTE:** All component dimensions given in U.S. inches  
1 inch = 25.4 mm

## Engine Power Rating Information

The gross power rating for individual gas engine models is labeled in accordance with SAE (Society of Automotive Engineers) code J11940 (Small Engine Power & Torque Rating Procedure), and rating performance has been obtained and corrected in accordance with SAE J1995 (Revision 2002-5). Actual gross engine power will be lower and is affected by, among other things, ambient operating conditions and engine-to-engine variability. Given both the wide array of products on which engines are placed and the variety of environmental issues applicable to operating the equipment, the gas engine will not develop the rated gross power when used in a given piece of power equipment (actual "on-site" or net horsepower). This difference is due to a variety of factors including, but not limited to, accessories (air cleaner, exhaust, charging, cooling, carburetor, fuel pump, etc.), application limitations, ambient operating conditions (temperature, humidity, altitude), and engine-to-engine variability. Due to manufacturing and capacity limitations, Briggs & Stratton may substitute an engine of higher rated power for this Series engine.

# REPAIR PARTS

TRACTOR- -MODEL NO. BM155H107RBK (96061010602), PRODUCT NO. 960 61 01-06  
MOWER

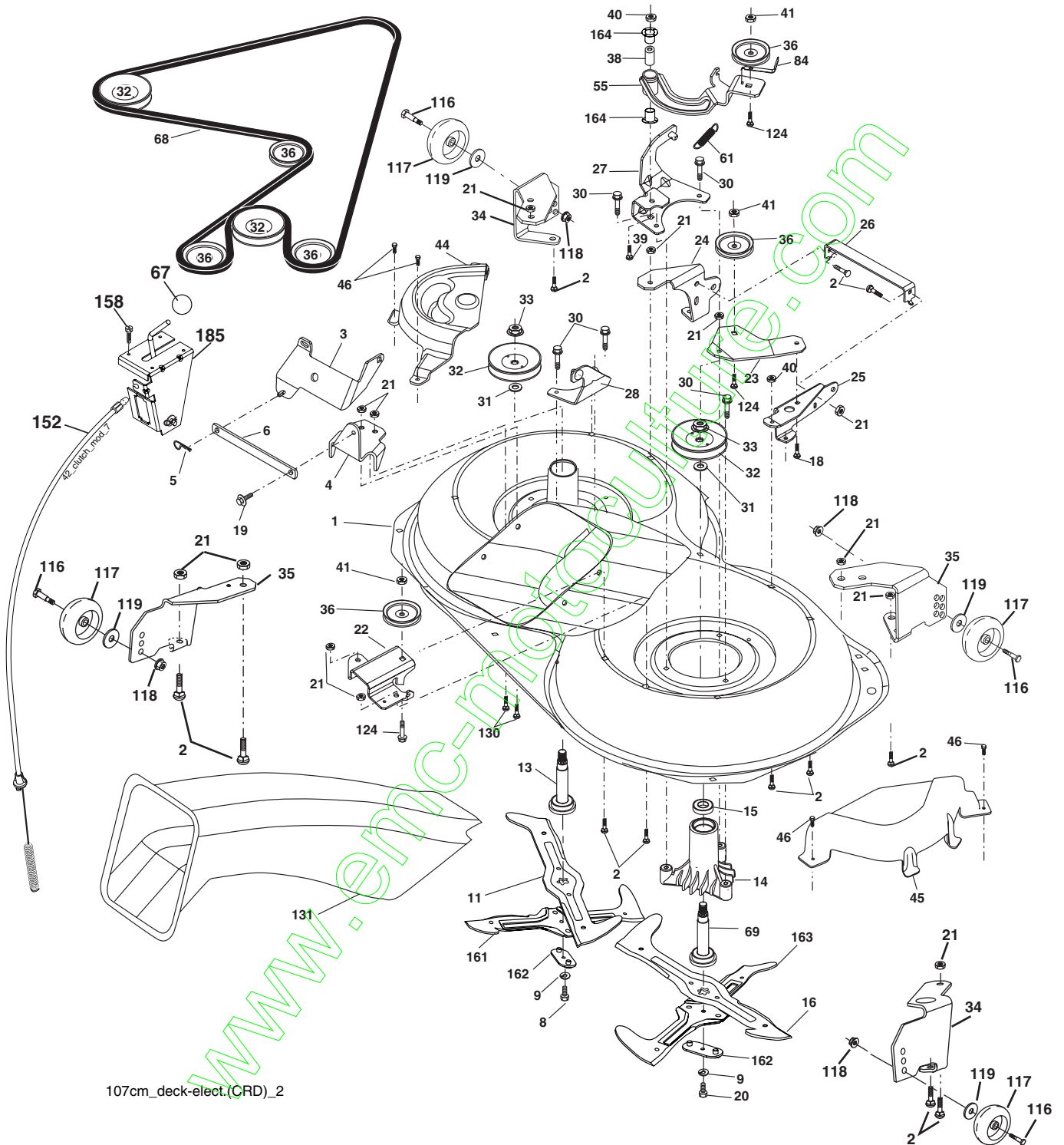

107cm\_deck-elect.(CRD)\_2



# REPAIR PARTS

TRACTOR- -MODEL NO. BM155H107RBK (96061010602), PRODUCT NO. 960 61 01-06  
MOWER

KEY NO.	PART NO.	DESCRIPTION	KEY NO.	PART NO.	DESCRIPTION
1	532 16 91-60	Housing Asm. Mower	39	872 11 06-22	Bolt RhHd 3/8-16 unc x 2-3/4 Gr.5
2	872 14 05-06	Bolt Rdhd Sqnk 5/16-18 unc x 3/4	40	873 68 06-00	Nut Crownlock 3/8-16 unc
3	532 16 55-69	Bracket Asm. S-Bar Chass	41	873 90 06-00	Nut Flangelock 3/8-16 unc
4	532 16 91-67	Bracket Bar Sway Deck	44	532 17 55-38	Cover Mandrel Lh
5	532 12 46-70	Retainer Spring	45	532 17 55-39	Cover Mandrel Rh
6	532 16 55-57	Bar Sway	46	532 13 77-29	Screw Thd Roll 1/4-20 x 5/8
8	532 18 17-12	Bolt 3/8-24 x 1.25 Gr. 8 Patched	55	532 16 98-49	Arm Idler
9	810 03 06-00	Washer Lock Hvy 3/8 Unplated	61	532 19 94-87	Spring Tension Belt
11	532 18 05-83	Blade 3-1 Lh	67	532 10 69-32	Knob
13	532 13 76-45	Shaft Asm. W/Lower Bearing	68	532 16 91-78	Hex-Belt Mower
14	532 12 87-74	Housing Mandrel Vented (Machd)	69	532 16 54-82	Shaft Asm W/Lwr Brg Rh Thd
15	532 11 04-85	Bearing Ball Mandrel	84	532 15 60-85	Keeper Belt Idler
16	532 18 05-84	Blade 3-1 Rh	116	532 18 42-19	Bolt Shoulder
18	872 11 06-06	Bolt Rdhd Sqnk 3/8-16 x 3/4 Gr. 5	117	532 17 48-73	Wheel Gage
19	532 13 28-27	Bolt Shoulder 5/16-18 Thd Form	118	873 93 06-00	Nut Centerlock 3/8-16 unc
20	532 18 17-13	Bolt 3/8-24 x 1.25 Gr. 8 Ptch	119	819 12 14-14	Washer 3/8 x 7/8 x 14 Ga.
21	873 68 05-00	Nut Crown Lock 5/16-18	124	872 11 06-12	Bolt Carr Sh 3/8-16 x 1-1/2 Gr. 5
22	532 16 91-65	Bracket Idler Sprt RR	130	872 11 05-06	Bolt Rdhdsqnk 5/16-18 unc x 3/4
23	532 16 91-66	Bracket Idler Sprt RF	131	532 16 56-61	Chute Bagger CRD 92cm
24	532 16 91-70	Bracket Suspension LF	152	532 17 60-74	Cable Clutch
25	532 40 01-05	Bracket Suspension RF	158	817 72 04-08	Screw 1/4-20 x 1/2
26	532 40 01-10	Brace Susp Frt CRD	161	532 18 04-24	Blade Cross LH 107
27	532 16 91-72	Bracket Asm. Susp RR	162	532 18 08-78	Adapter Weldment Blade 107
28	532 16 91-68	Bracket Asm. Susp LR	163	532 18 04-25	Blade Cross RH 107
30	532 17 39-84	Screw Thd Rolling Dod.PT Hex	164	532 12 49-37	Bearing
31	532 18 76-90	Washer Spacer Mower Vented	185	532 18 82-34	Head Asm Cable Clutch
32	532 19 81-45	Mandrel Pulleys	--	532 18 18-57	Mandrel Asm Service
33	532 40 02-34	Nut Flg Top Lock	--	532 18 18-58	Mandrel Asm CRD Lh Threads
34	532 40 01-03	Bracket Gauge Wheel Lf	--	532 40 13-76	Replacement Mower Complete
35	532 40 01-04	Bracket Gauge Wheel Rf			
36	532 14 67-63	Pulley Idler V-Groove Dim 4.25			
38	532 16 98-51	Spacer Hub Arm Idler			

**NOTE:** All component dimensions given in U.S. inches  
1 inch = 25.4 mm

# REPAIR PARTS

TRACTOR- -MODEL NO. BM155H107RBK (96061010602), PRODUCT NO. 960 61 01-06  
MOWER LIFT

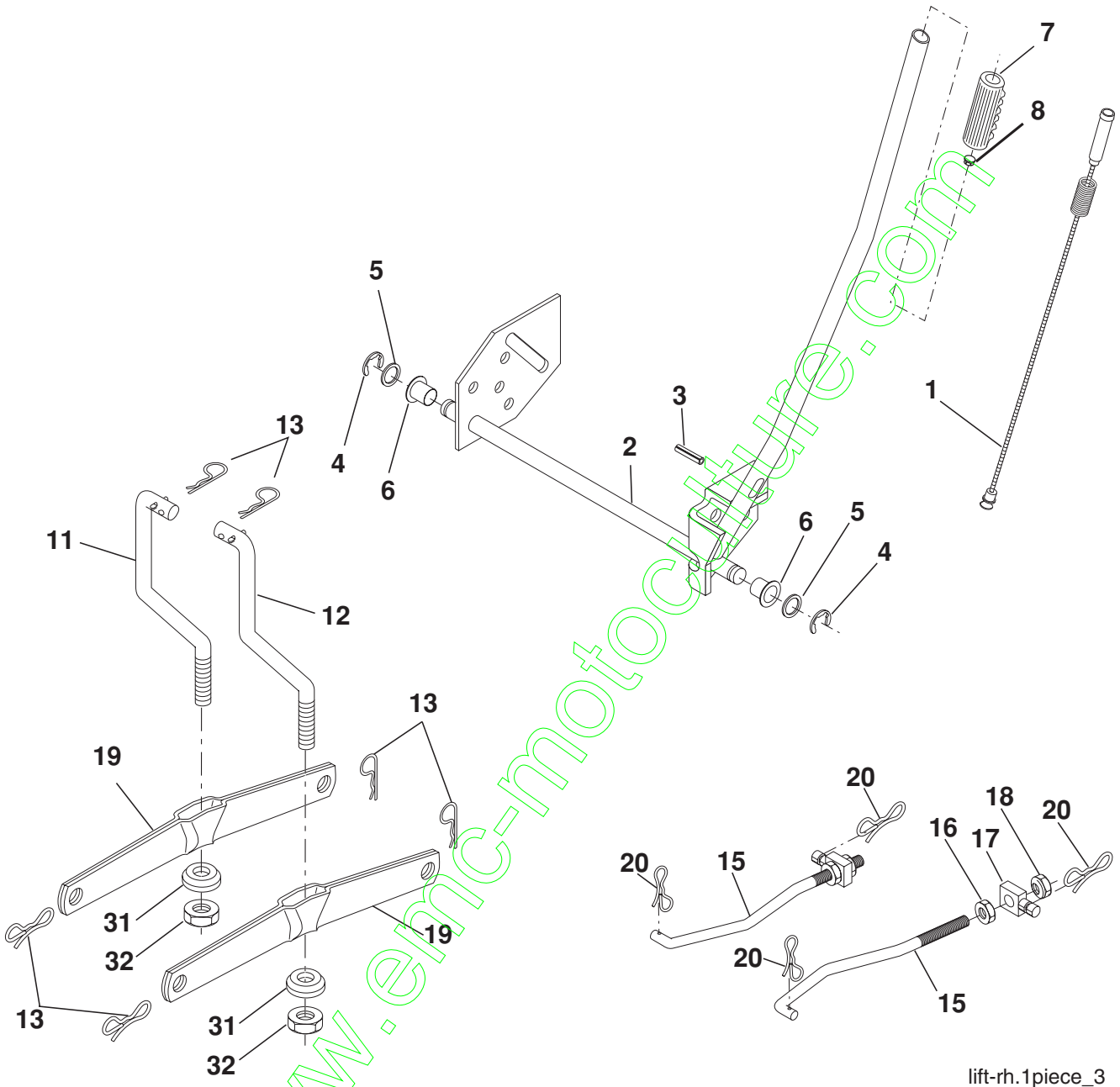

KEY NO.	PART NO.	DESCRIPTION
1	532 19 84-17	Washer Asm Inner Spring W/ Plunger
2	532 19 80-70	Shaft Asm. Lift
3	532 18 88-22	Pin Groove
4	812 00 00-02	E Ring #5133-62
5	819 21 16-21	Washer 21/32 x 1 x 21 Ga.
6	532 12 01-83	Bearing Nylon
7	532 10 94-13	Grip Handle
8	532 12 45-26	Button Plunger
11	532 16 58-29	Link Asm Lift L.H.
12	532 16 58-31	Link Asm Lift R.H.

KEY NO.	PART NO.	DESCRIPTION
13	532 12 46-70	Retainer Spring
15	532 17 32-88	Link Front
16	873 35 08-00	Nut Jam Hex 1/2-13 unc
17	532 17 56-89	Trunnion Blk Zinc
18	873 80 08-00	Nut Lock w/wsh 1/2-13 unc
19	532 13 98-68	Arm Suspension Mower
20	532 19 42-09	Pin Cotter 7/16 Bow Tie Lock
31	532 16 98-65	Bearing, Pvt. Lift.
32	873 54 06-00	Nut Crownlock 3/8-24

**NOTE:** All component dimensions given in U.S. inches  
1 inch = 25.4 mm

# REPAIR PARTS

TRACTOR- -MODEL NO. BM155H107RBK (96061010602), PRODUCT NO. 960 61 01-06  
BAGGER

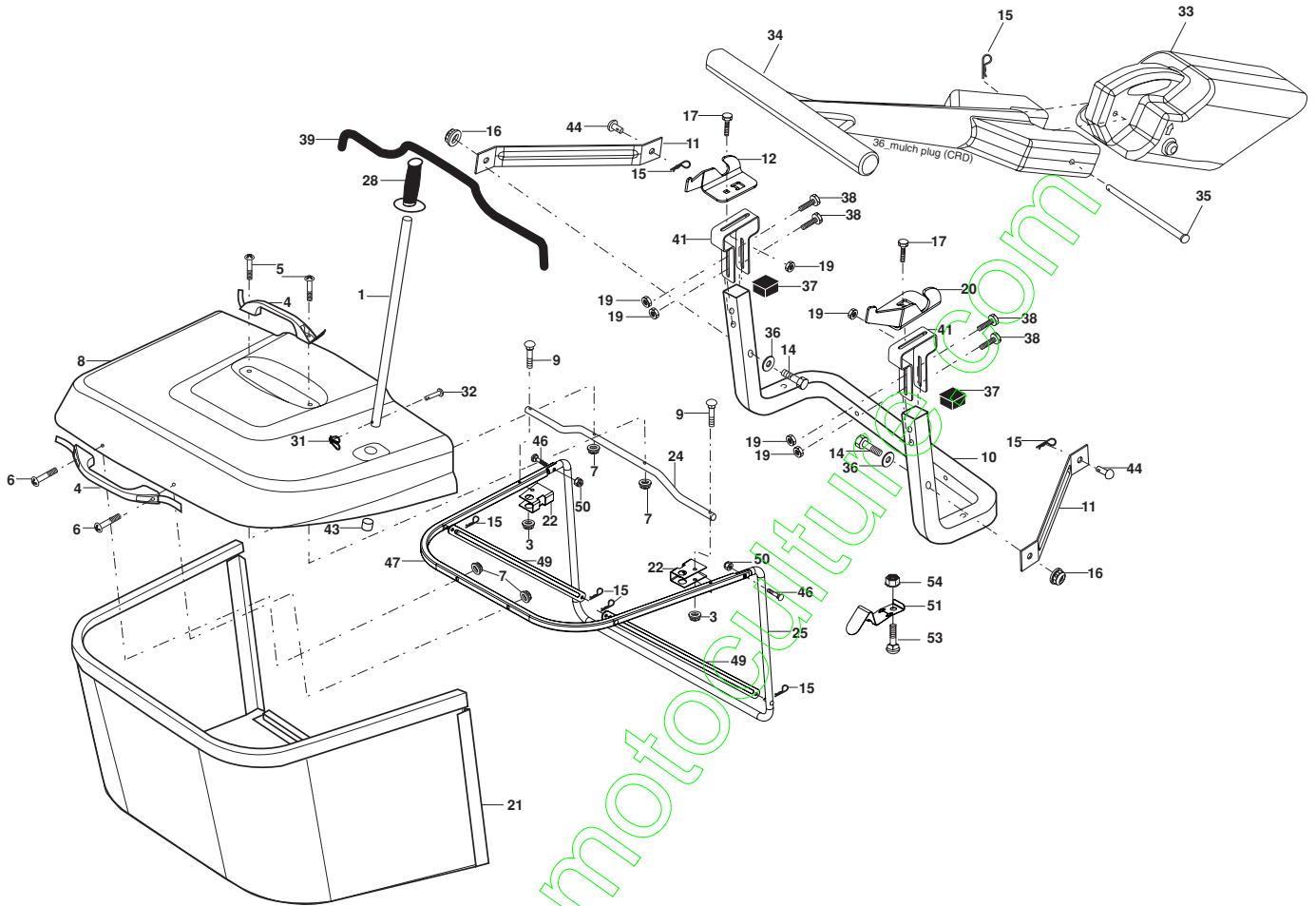

Bagger Asy (CRD)\_10

KEY NO.	PART NO.	DESCRIPTION
1	532 16 52-49	Tube Handle Bagger CRD
3	532 12 39-76	Nut Lock 1/4 Lge Flg Gr. 5 Zinc
4	532 16 99-16	Handle Bagger w/Lvrs Blk CRD
5	874 98 10-24	Screw Pan Head #10-24 x 1.50
6	874 98 10-32	Screw Pan Hd
7	873 40 10-00	Nut Wiz Lock Hex Serr/Hd 10-24
8	532 19 24-70	Cover Bagger
9	872 14 04-18	Bolt Carriage 1/4-20 x 2.25d x Gr. 5
10	532 18 12-82	Tube Support Bagger CRD
11	532 16 57-19	Bracket Support Upper Bag CRD
12	532 18 88-48	Bracket Pivot LH
14	874 52 06-36	Bolt Fin Hex 3/8-16 x 2-1/4 Gr.5
15	532 12 46-70	Retainer Spring
16	873 90 06-00	Nut Lock 3/8-16 unc
17	872 14 05-06	Bolt Rdhd Sht Sqnk 5/16 -18 unc x 3/4
19	873 90 05-00	Nut Lock Hex Flange 5/16-18
20	532 18 88-47	Bracket Pivot Rh
21	532 19 38-38	Bag Asm CRD
22	532 16 57-81	Bracket Side Bagger CRD
24	532 16 57-83	Tube Pivot Bagger CRD

KEY NO.	PART NO.	DESCRIPTION
28	532 16 57-87	Grip Handle
31	532 16 94-84	Retainer Clip
32	532 12 68-75	Rivet Rd Hd Drilled 3/8 Dia
33	532 16 93-80	Plug Mulcher
34	532 16 55-70	Handle Mulcher
35	532 16 55-72	Pin Mulcher
36	819 13 20-12	Washer 13/32 x 1-1/4 x 12 Ga.
37	532 17 54-01	Plug Support Bagger CRD
38	872 01 05-20	Bolt 5/16-18 x 2-1/2
39	532 18 09-85	Seal
41	532 16 96-83	Bracket Pnt Adj Pvt Bagger CRD
43	532 17 40-83	Plug Tubing End
44	532 19 33-12	Pin Clevis 3/8 x 11/16
46	872 11 05-10	Bolt 5/16-18 x 1-1/4
47	532 19 37-04	Tube Upper Bagger
49	532 19 33-05	Bar Spreader
50	873 80 05-00	Nut 5/16-18
51	532 19 99-03	Latch Spring Bagger
53	873 51 04-00	Nut 1/4-20 unc
54	872 14 04-06	Bolt 1/4-20 x 3/4 Gr.5

**NOTE:** All component dimensions given in U.S. inches  
1 inch = 25.4 mm

[www.emc-motoculture.com](http://www.emc-motoculture.com)

***BESTGREEN***