

REPAIR PARTS MANUAL
MODEL NO. BM155H107RBK (96061010605)
LAWN TRACTOR

BESTGREEN

HOW TO USE THIS MANUAL

This manual is designed to provide the customer with a means to identify the parts on his/her tractor when ordering repair parts. The illustrations may or may not represent the actual assemblies; therefore, it is not recommended to use this manual as a guide to assemble or disassemble the tractor. Some hardware and parts are drawn larger in order to more readily identify them.

Each tractor has its own model number.

The model number for your tractor can be found on the fender under the seat.

When ordering parts, always give the following information:

- Product - "Tractor"
- Model Number - "BM155H107RBK (96061010605)"
- Part Number
- Part Description

TABLE OF CONTENTS

SCHEMATIC	3
ELECTRICAL	4-5
CHASSIS	6-7
DRIVE	8-9
STEERING	10-11
SEAT	12
DECALS	13
ENGINE	14-15
MOWER DECK	16-17
MOWER LIFT	18
BAGGER	19

TRACTOR- -MODEL NO. BM155H107RBK (96061010605), PRODUCT NO. 960 61 01-06 SCHEMATIC

SCH08

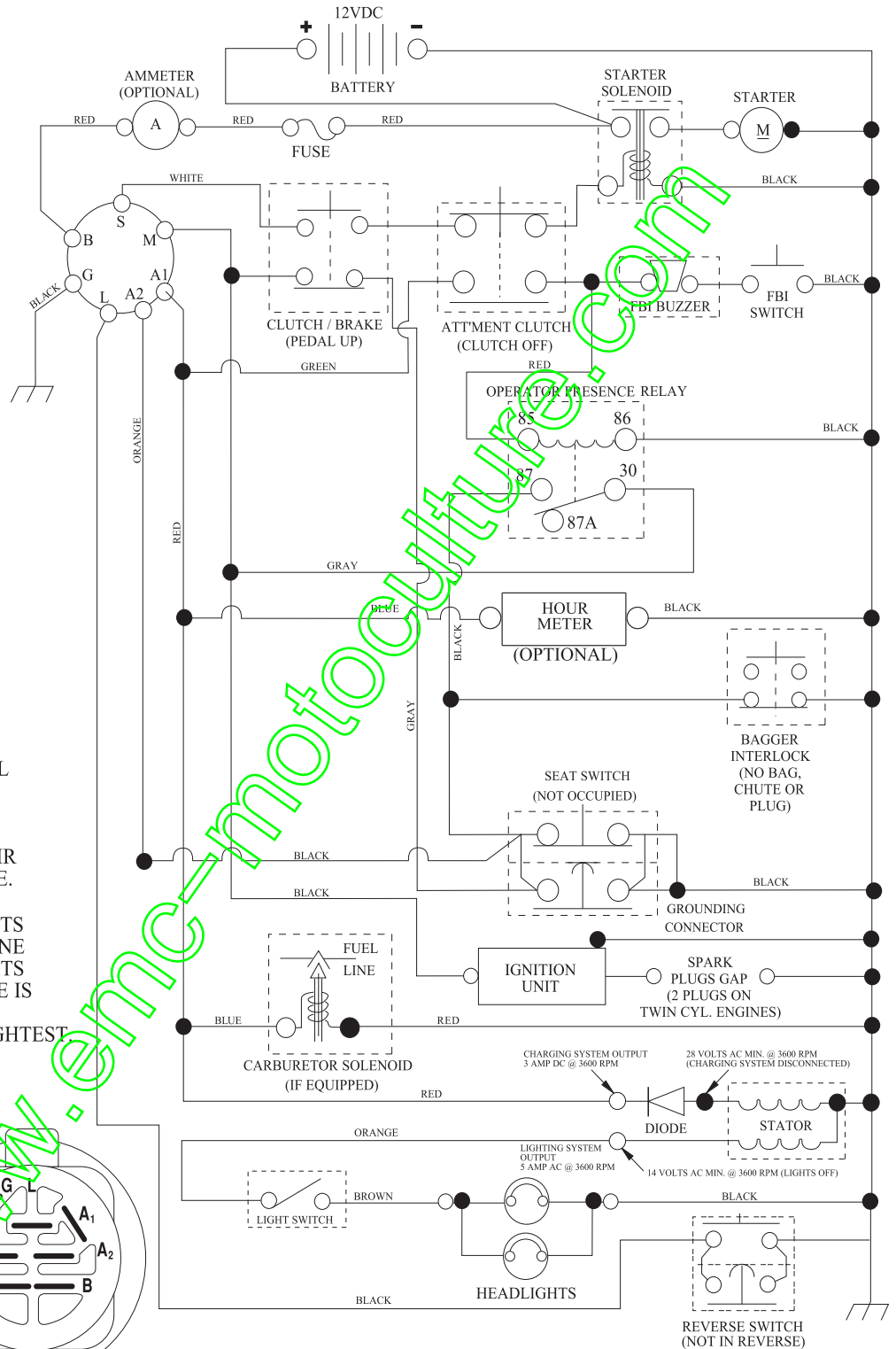

NOTE
 YOUR TRACTOR IS EQUIPPED WITH A SPECIAL ALTERNATOR SYSTEM. THE LIGHTS ARE NOT CONNECTED TO THE BATTERY, BUT HAVE THEIR OWN ELECTRICAL SOURCE. BECAUSE OF THIS, THE BRIGHTNESS OF THE LIGHTS WILL CHANGE WITH ENGINE SPEED. AT IDLE THE LIGHTS WILL DIM. AS THE ENGINE IS SPEEDED UP, THE LIGHTS WILL BECOME THEIR BRIGHTEST.

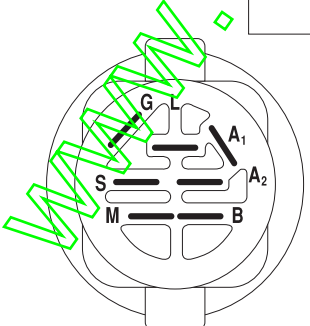

IGNITION SWITCH

POSITION	CIRCUIT "MAKE"
OFF	M+G+A1
RUN/OVERRIDE	B+A1
RUN	B+A1 L+A2
START	B + S + A1

WIRING INSULATED CLIPS
 NOTE: IF WIRING INSULATED CLIPS WERE REMOVED FOR SERVICING OF UNIT, THEY SHOULD BE RE-INSTALLED TO PROPERLY SECURE YOUR WIRING.

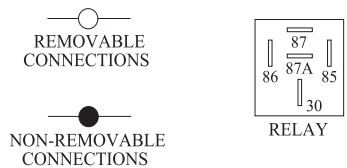

TRACTOR- -MODEL NO. BM155H107RBK (96061010605), PRODUCT NO. 960 61 01-06
ELECTRICAL

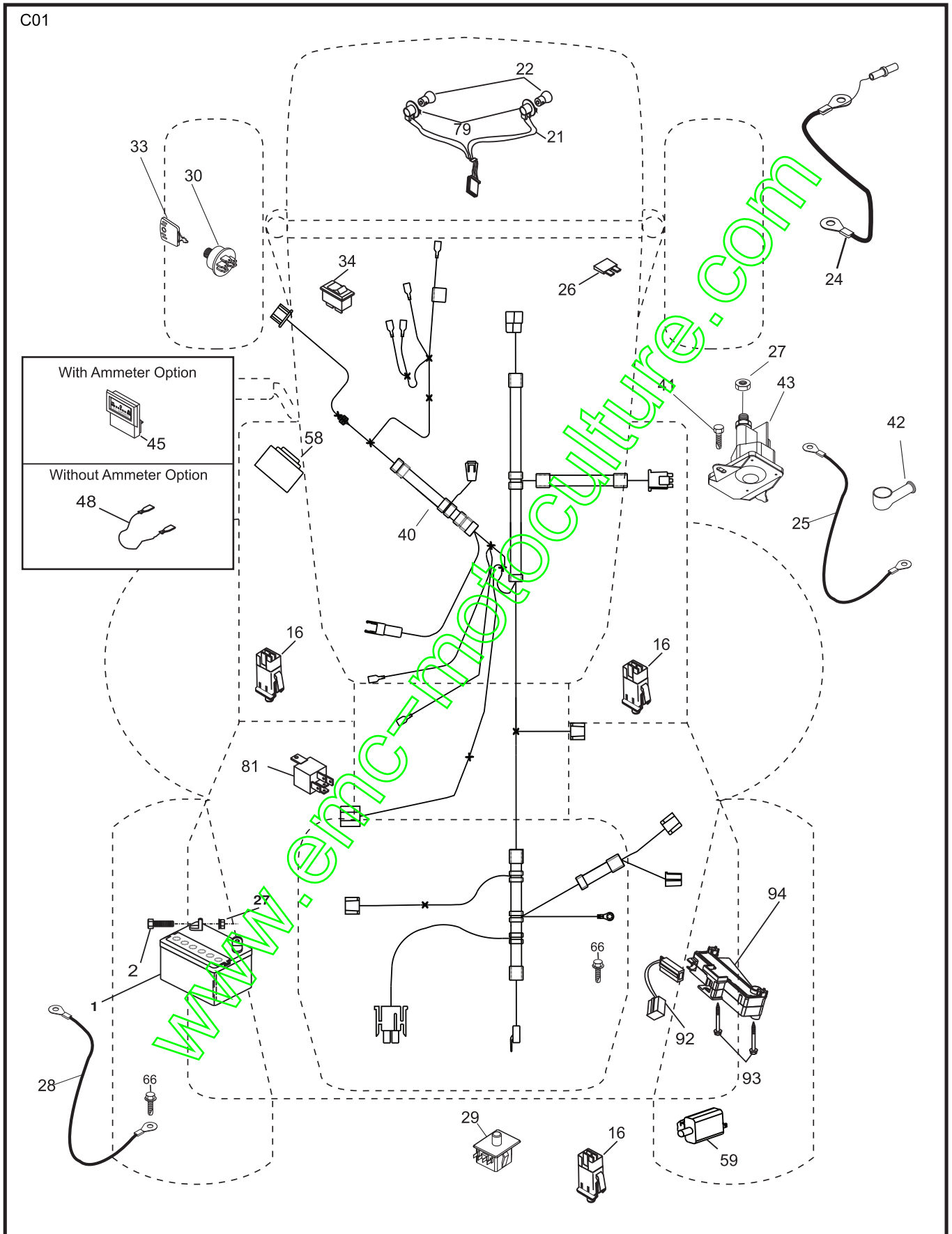

**TRACTOR- -MODEL NO. BM155H107RBK (96061010605), PRODUCT NO. 960 61 01-06
ELECTRICAL**

KEY NO.	PART NO.	DESCRIPTION
1	532 16 34-65	Battery
2	874 76 04-12	Bolt Hex Hd 1/4-20 unc x 3/4
16	532 17 61-38	Switch Interlock
21	532 18 37-59	Harness Asm Light w/4152J
22	532 00 41-52	Bulb Light #1156
24	532 42 12-99	Cable Starter 6 Ga. 11" Red
25	532 16 59-87	Cable Battery CRD 56" Red
26	532 17 51-58	Fuse
27	873 51 04-00	Nut Keps Hex 1/4-20 unc
28	532 12 77-25	Cable Ground 6 Ga. 18" Black
29	532 19 27-49	Switch Seat
30	532 19 33-50	Switch Ignition
33	532 41 19-35	Key/Chain
34	532 11 07-12	Switch Light
40	532 19 74-36	Harness Ign
41	871 11 04-08	Bolt Flk Fin Hex 1/4-20 unc x 1/2
42	532 13 15-63	Cover Terminal Red
43	532 19 25-07	Solenoid
48	532 14 08-44	Adapter Ammeter Rectangular
58	532 16 94-19	Buzzer CRD
59	532 18 03-79	Switch FBI CRD
66	817 49 06-08	Screw Thdrol 3/8-16 x 1/2 Ty-Tt
79	532 17 52-42	Socket Asm. Bulb Twistlock
81	532 10 97-48	Relay Asm
92	532 19 66-15	Harness Pigtail
93	532 19 25-40	Screw Plastite 10-44 x 2.0
94	532 19 18-34	Module Reverse

NOTE: All component dimensions given in U.S. inches.
1 inch = 25.4 mm.

**TRACTOR- -MODEL NO. BM155H107RBK (96061010605), PRODUCT NO. 960 61 01-06
CHASSIS AND ENCLOSURES**

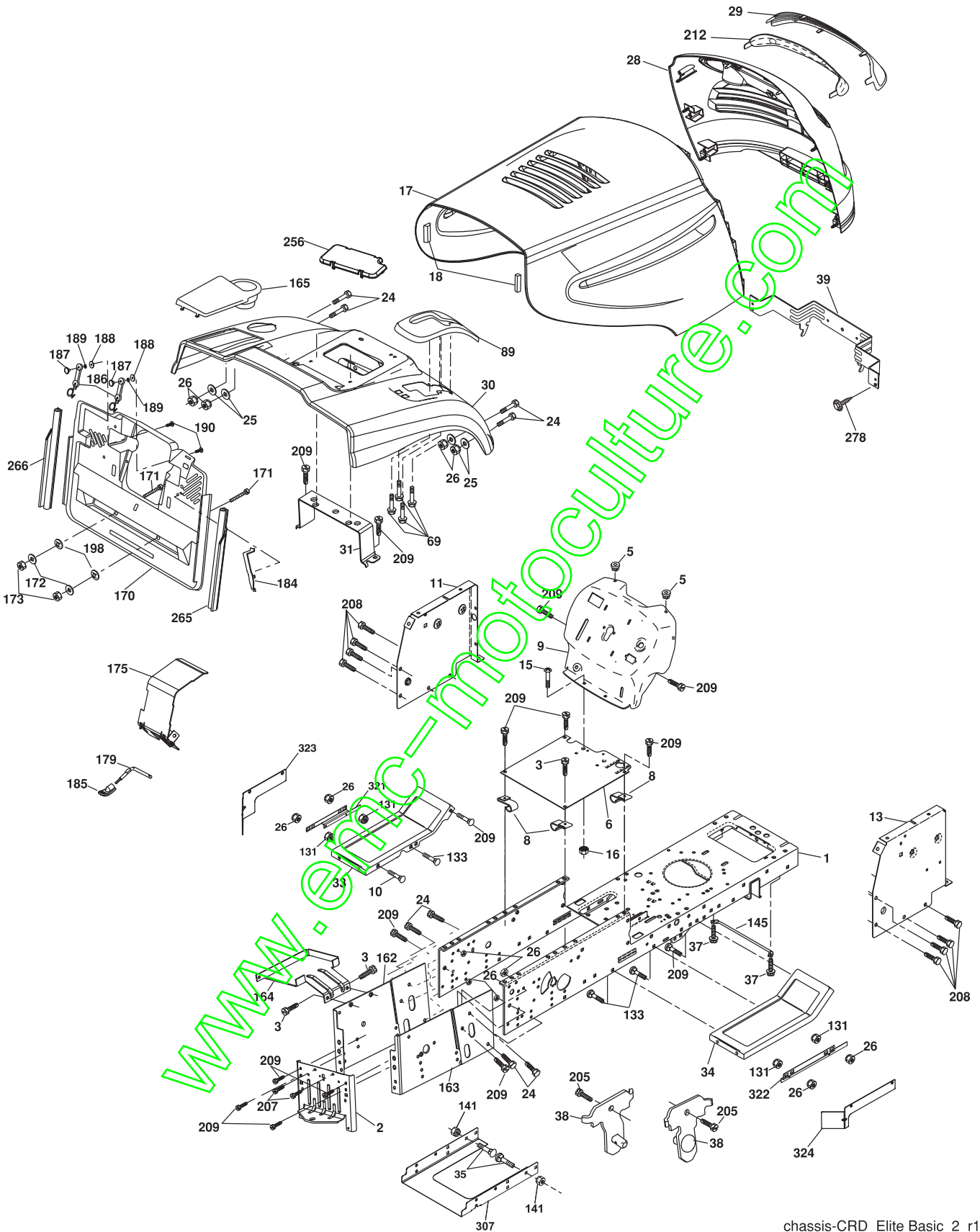

chassis-CRD_Elite Basic_2_r1

**TRACTOR- -MODEL NO. BM155H107RBK (96061010605), PRODUCT NO. 960 61 01-06
CHASSIS AND ENCLOSURES**

KEY NO.	PART NO.	DESCRIPTION	KEY NO.	PART NO.	DESCRIPTION
1	532 17 46-20	Chassis	165	532 18 13-56	Cover Battery CRD
2	532 18 03-84	Drawbar	170	532 19 94-88	Backplate CRD
3	817 06 06-12	Screw 3/8-16 x .75	171	872 14 06-20	Bolt Rdhd Sqnk 3/8-16 x 2-1/2 G5
5	532 15 52-72	Bumper Hood/Dash	172	819 13 20-16	Washer 13/32 x 1-1/4 x 16 Ga.
6	532 18 44-19	Saddle	173	873 51 06-00	Nut, Keys Hex 3/8-16 unc
8	532 12 64-71	Clip Insulator 13/32 Mtg. Hole	175	532 18 82-03	Trap Door CRD
9	532 19 46-88	Dash	179	532 18 82-02	Rod Pivot FBI CRD
10	872 14 06-10	Bolt, Carriage 3/8-16 x 1-1/4	184	532 17 46-62	Bracket Actuator Bagger CRD
11	532 17 49-96	Panel, Dash, LH	185	532 18 11-01	Knob Rod
13	532 18 69-52	Panel, Asm. Dash RH	186	532 16 07-93	Latch Asm Multch Bagger
15	874 18 05-12	Screw, Machine, Truss Head 5/16-18 unc x 3/4	187	532 12 50-04	Nut Weld .327/.304 #10-24
16	873 51 05-00	Nut	188	819 06 12-16	Washer #10
17	532 19 24-37	Hood Assembly	189	810 07 10-00	Washer Lock #10
18	532 18 49-21	Bumper Hood	190	871 08 10-10	Screw Pan Hd Phillips 10-24 x 5/8
24	874 78 06-16	Bolt	198	532 16 89-37	Nut Push
25	819 13 13-12	Washer 13/32 x 13/16 x 12 Ga.	205	817 49 06-08	Screw 3/8-16 x 1/2
26	873 80 06-00	Nut	207	817 67 05-08	Screw 5/16-18 x 1/2
28	532 42 67-92	Grille	208	817 67 06-08	Screw Thdrol 3/8-16 x 1/2
29	532 18 98-37	Lens Grille	209	817 09 06-12	Screw Hex Wsh Thdrol 3/8-16 x 3/4
30	532 19 73-56	Fender	212	532 18 38-23	Insert Lens
31	532 16 51-56	Bracket, Fender Support	256	532 18 13-61	Cover Fender Rack CRD
33	532 18 64-57	Footrest, LH	265	532 18 57-04	Seal, Side RH
34	532 18 64-58	Footrest, RH	266	532 18 57-03	Seal, Side LH
37	817 49 05-08	Screw Thdrol 5/16-18 x 1/2 TYT	278	532 41 63-58	Screw #10 x .750 BOS Thread
38	532 18 17-48	Bracket Asm Pivot Mower Rear	307	532 42 51-25	Shield Chassis Front
39	532 40 78-07	Bracket Pivot	321	532 43 03-09	Shield Deck Inner LH
69	532 14 24-32	Screw Hex 1/4-1/2	322	532 43 10-14	Shield Deck Inner RH
89	532 19 73-66	Console	323	532 43 24-00	Assy. CRD LH Outside Deck Shield
131	873 22 06-00	Nut Fin Hex 3/8-16 unc	324	532 43 24-01	Assy. CRD RH Outside Deck Shield
133	872 11 06-08	Bolt Rdhd Sqnk. 3/8-16 x 1 Gr. 5	--	532 00 54-79	Plug, Button
141	873 90 06-00	Nut			
145	532 40 91-67	Rod Pivot Chassis/Hood			
162	532 18 03-82	Bracket Exten Chassis LH CRD			
163	532 18 03-83	Bracket Exten Chassis RH CRD			
164	532 16 56-05	Support Battery CRD			

NOTE: All component dimensions given in U.S. inches.
1 inch = 25.4 mm.

TRACTOR- -MODEL NO. BM155H107RBK (96061010605), PRODUCT NO. 960 61 01-06
DRIVE

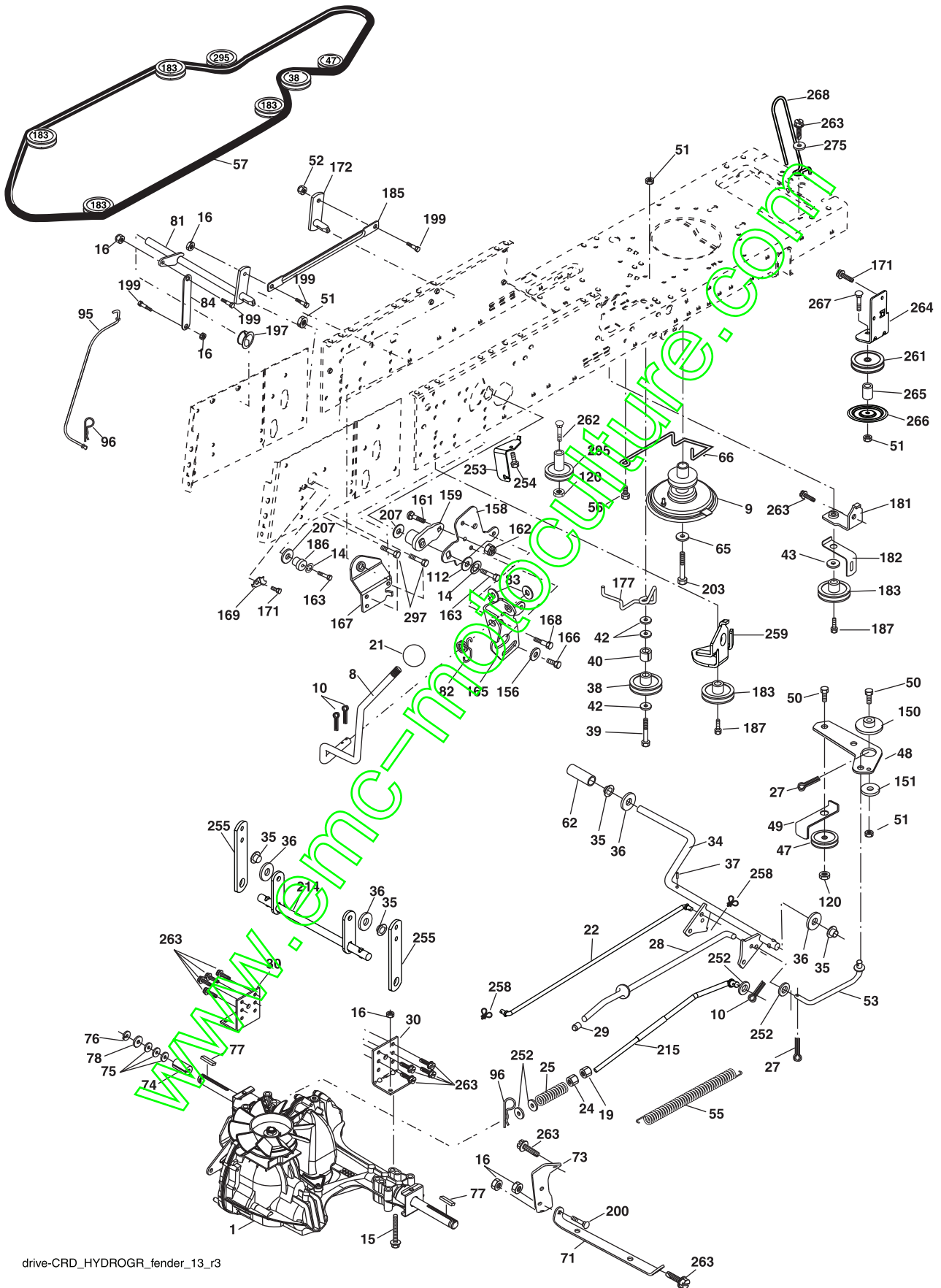

drive-CRD_HYDROGR_fender_13_r3

**TRACTOR- -MODEL NO. BM155H107RBK (96061010605), PRODUCT NO. 960 61 01-06
DRIVE**

KEY NO.	PART NO.	DESCRIPTION	KEY NO.	PART NO.	DESCRIPTION
1	-----	Transaxle Hydro Gear 321-0510	120	873 90 06-00	Nut Lock Flg. 3/8-16 unc
8	532 19 27-06	Rod, Shift Fender Adjust Lt	150	532 16 58-50	Bushing, Bellcrank Grnd Dr
9	532 40 85-79	Clutch Asm Noram	151	819 13 32-10	Washer 13/32 x 2 x 10 Ga.
10	876 02 04-16	Pin, Cotter 1/8 x 1	156	532 16 60-02	Washer Srted 5/16 ID x 1.125
14	810 04 04-00	Washer, Lock Hvy Helical	158	532 16 55-89	Bracket Shift Mount
15	874 49 05-44	Bolt Hex FGHD 5/16-18 x Gr. 5	159	532 18 39-00	Hub Shift
16	873 80 05-00	Nut Lock Hex w/lns 5/16-18 unc	161	872 14 04-06	Bolt Rdhd Sqnk 1/4-20 x 3/4 Gr. 5
19	873 80 06-00	Nut Lock Hex w/lns 3/8-16 unc	162	873 68 04-00	Nut Crownlock 1/4-20 unc
21	532 10 69-33	Knob	163	874 78 04-16	Bolt Hex Fin 1/4-20 unc x 1 Gr. 5
22	532 17 56-07	Rod Brake Main	165	532 16 56-23	Bracket Pivot Lever
24	873 35 06-00	Nut Hex Jam 3/8-16 unc	166	817 49 05-10	Screw 5/16-18 x 5/8
25	532 19 20-36	Spring, Rod, Brake	167	532 16 55-88	Bracket Support Shift CRD
27	876 02 04-12	Pin, Cotter 1/8 x 3/4	168	532 16 54-92	Bolt Shoulder 5/16-18 x .561
28	532 17 57-65	Rod, Parking Brake	169	532 16 55-80	Plate Fastening Lt
29	532 07 16-73	Cap, Parking Brake	171	817 49 06-08	Screw Thdrol 3/8-16 x 1/2 Ty-Tt
30	532 16 95-92	Bracket, Mfg. Transaxle	172	532 17 02-71	Shaft Asm Shifter Frt CRD
34	532 17 55-78	Shaft, Asm Pedal Foot CRD	177	532 16 59-82	Keeper Flat Idler 3.06" CRD
35	532 12 01-83	Bearing, Nylon	181	532 18 02-11	Bracket Idler Ground Drive CRD
36	819 21 16-16	Washer 21/32 x 1 x 16 Ga.	182	532 18 26-82	Keeper Belt 2.5" Od V-Idler CRD
37	532 12 49-63	Pin, Roll 3/16 x 1"	183	532 19 95-34	Pulley V-Idler 2.50" Od CRD
38	532 16 59-36	Pulley Flat Composite 3.06"	185	532 17 00-08	Link Shift
39	874 76 06-44	Bolt Fin Hex 3/8-16 unc x 2-3/4	186	532 16 56-14	Hub Tapered Round CRD
40	532 12 49-65	Spacer, Split 395 x 59 Bzp	187	817 58 05-20	Screw Thdrol 5/16-18 x 1.25
42	819 13 13-12	Washer 13/32 x 13/16 x 12 Ga.	197	532 16 96-13	Nyliner Snap-In 5/8
43	819 11 10-12	Washer 11/32 x 5/8 x 12 Ga.	199	532 16 96-12	Bolt Shoulder 5/16-18 unc
47	532 12 77-83	Pulley, Idler, V Groove Plastic	200	872 14 05-08	Bolt RDHD SQNK 5/16-18 x 1
48	532 15 44-07	Bellcrank Clutch Grnd Drv	203	871 17 07-80	Bolt Hex 7/16-20 x 5
49	532 12 32-05	Retainer, Belt Style Spring	207	532 16 98-45	Washer Nylon Rear
50	872 11 06-12	Bolt Carr. Sh. 3/8-16 x 1-1/2 Gr. 5	214	532 17 56-09	Shaft Asm. Brake
51	873 68 06-00	Nut, Crownlock 3/8-16 unc	215	532 17 56-52	Rod Brake Hydro
52	873 68 05-00	Nut, Crownlock 5/16-18	252	819 13 16-16	Washer 13/32 x 1 x 16 Ga.
53	532 19 96-52	Link, Clutch 7.66	253	532 17 50-28	Bracket Cable Chassis
55	532 10 57-09	Spring, Return, Clutch	254	817 00 06-16	Screw 3/8-16 x 1
56	817 06 06-20	Screw 3/8-16 x 1-1/4	255	532 17 56-08	Brace Shaft Brake Mtg.
57	532 17 01-40	V-Belt Kev 112" 0650 CRD	258	532 17 80-62	Clip Retainer
62	532 12 48-72	Cover, Pedal	259	532 18 02-12	Bracket Pulley
65	810 04 07-00	Washer	261	532 13 14-94	Pulley Idler
66	532 15 47-78	Keeper, Belt Engine F-Proof	262	872 11 06-22	Bolt Carr. 3/8-16 x 2-3/4 Gr. 5
71	532 16 91-83	Strap, Torque, LH	263	817 00 06-12	Screw 3/8-16 x 3/4
73	532 16 91-82	Strap, Torque, RH	264	532 43 11-74	Bracket Idler Chassis
74	532 13 70-57	Spacer, Split	265	532 42 69-13	Spacer Idler
75	532 12 17-49	Washer 25/32 x 1-1/4 x 16 Ga.	266	532 18 20-61	Shield Idler Mower
76	812 00 00-01	Ring, E	267	872 14 06-26	Bolt Rd Hd SQNK 3/8-16 x 3-1
77	532 12 35-83	Key, Square	268	532 18 24-02	Guard Muffler RH
78	532 12 17-48	Washer 25/32 x 1-5/8 x 16 Ga.	275	819 13 16-14	Washer 13/32 x 1 x 14 Ga.
81	532 17 00-06	Asm, Shaft, Cross Rear	295	532 17 91-14	Pulley Idler Composite
82	532 16 57-11	Spring, Torsion	297	817 49 06-10	Screw HXWSH THDR. 3/8-16 x 5/8
83	819 17 12-16	Washer 17/32 x 3/4 x 16 Ga.			
84	532 17 00-07	Link, Transaxle			
95	532 17 00-15	Control Asm Bypass Hydro			
96	532 12 47-88	Spring, Retainer 1"			
112	819 09 12-10	Washer 9/32 x 3/4 x 10 Ga.			

NOTE: All component dimensions given in U.S. inches
1 inch = 25.4 mm

TRACTOR- -MODEL NO. BM155H107RBK (96061010605), PRODUCT NO. 960 61 01-06
STEERING ASSEMBLY

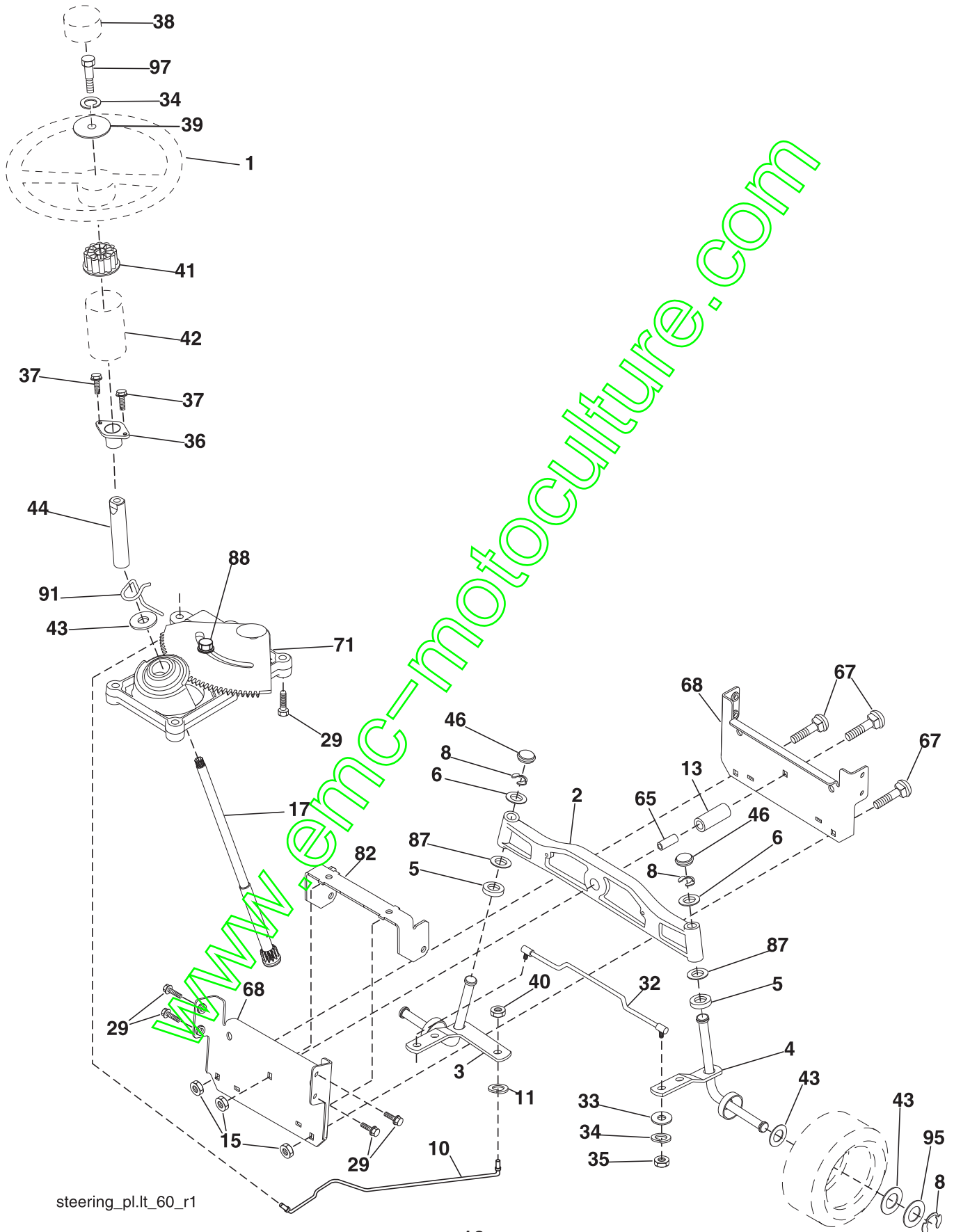

steering_pl.lt_60_r1

**TRACTOR- -MODEL NO. BM155H107RBK (96061010605), PRODUCT NO. 960 61 01-06
STEERING ASSEMBLY**

KEY NO.	PART NO.	DESCRIPTION
1	532 19 45-95	Steering Wheel
2	532 18 47-06	Front Axle Assembly
3	532 16 98-40	Spindle Assembly, LH
4	532 16 98-39	Spindle Assembly, RH
5	532 12 49-31	Washer Thrust .75 x 1.230
6	532 12 17-48	Washer 25/32 x 1-5/8 x 16 Ga.
8	812 00 00-29	Ring, Klip
10	532 17 51-21	Link, Drag
11	810 04 06-00	Washer, Lock
13	532 13 65-18	Spacer Axle
15	873 90 06-00	Nut Flange Lock
17	532 19 07-53	Shaft Assembly, Steering
29	817 00 06-12	Screw 3/8-16 x 3/4
32	532 17 01-62	Rod, Tie
33	819 11 12-16	Washer 11/32 x 3/4 x 16 Ga.
34	810 04 05-00	Washer Lock Hvy Hlcl Spr 5/16
35	873 54 05-00	Crownlock Nut 5/16-24 unf
36	532 15 50-99	Bushing, Steering
37	532 15 29-27	Screw TT #10 32 x 5 x 3/8 Flange
38	532 19 46-03	Cap Wheel Steering
39	819 11 38-12	Washer 11/32 ID x 2-3/8 OD x 12 Ga.
40	873 54 06-00	Nut Crownlock 3/8-24
41	532 18 67-37	Adaptor, Steering Wheel
42	532 16 96-33	Boot, Steering Dash P/L Mtl
43	532 12 17-49	Washer 25/32 x 1-1/4 x 16 Ga.
44	532 19 07-52	Extension Steering
46	532 12 12-32	Cap, Spindle
65	532 41 47-36	Spacer Axle
67	872 11 06-18	Bolt Rdhd Sq 3/8-16 x 2-1/4
68	532 16 98-27	Brace Axle
71	532 17 51-46	Steering Asm.
82	532 19 99-78	Bracket Susp. Chassis Front
87	532 17 39-66	Washer Flat .781 x 1-1/2 x .14
88	532 17 51-18	Bolt Shoulder 7/16-20 unc
91	532 17 55-53	Clip Steering
95	532 18 89-67	Washer
97	532 42 89-82	Bolt 5/16-18 x 4 w/Patch

NOTE: All component dimensions given in U.S. inches.
1 inch = 25.4 mm.

**TRACTOR- -MODEL NO. BM155H107RBK (96061010605), PRODUCT NO. 960 61 01-06
SEAT ASSEMBLY**

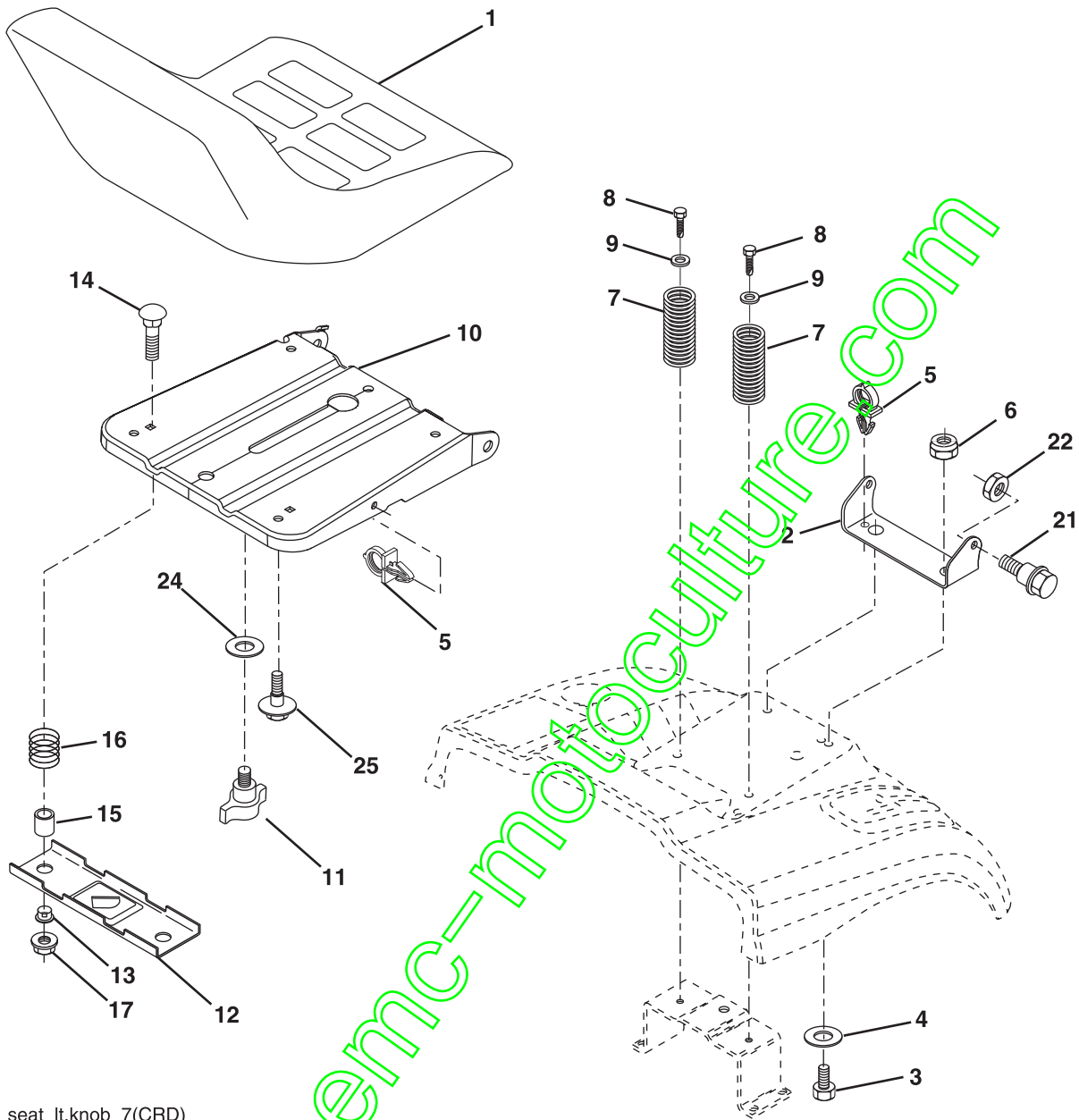

seat_lt.knob_7(CRD)

KEY NO.	PART NO.	DESCRIPTION
1	532 40 10-43	Seat
2	532 14 05-51	Bracket Pnt Pivot Seat (Blk)
3	871 11 06-16	Bolt Fin Hex 3/8-16 x 1
4	819 13 16-10	Washer Flat 13/32 x 1 x 10 Ga.
5	532 14 50-06	Clip Push In Hinged
6	873 80 06-00	Nut Lock Hex w/Ins 3/8-16
7	532 12 41-81	Spring Seat Cprsn 2 250 Blk Zi
8	817 00 06-16	Screw 3/8-16 x 1.5
9	819 13 16-14	Washer 13/32 x 1 x 14 Ga.
10	532 19 55-30	Pan Pnt Seat
11	532 16 63-69	Knob Seat Adj. Wingnut
12	532 17 46-48	Bracket Pnt Mounting Switch

KEY NO.	PART NO.	DESCRIPTION
13	532 12 12-48	Bushing Snap Blk Nyl 50 Id
14	872 05 04-12	Bolt Rdhd Sht Nk 1/4-20 x 1-1/2
15	532 12 12-49	Spacer Split
16	532 12 37-40	Spring Cprsn
17	532 12 39-76	Nut Lock 1/4 Lge Flg Gr. 5 Zinc
21	532 17 18-52	Bolt Shoulder 5/16-18 unc-2A
22	873 80 05-00	Nut Hex Lock w/Ins 5/16-18
24	819 17 19-12	Washer 17/32 x 1-3/16 x 12 Ga.
25	532 12 70-18	Bolt Shoulder 5/16-18 x 62

NOTE: All component dimensions given in U.S. inches.
1 inch = 25.4 mm

**TRACTOR- -MODEL NO. BM155H107RBK (96061010605), PRODUCT NO. 960 61 01-06
DECALS**

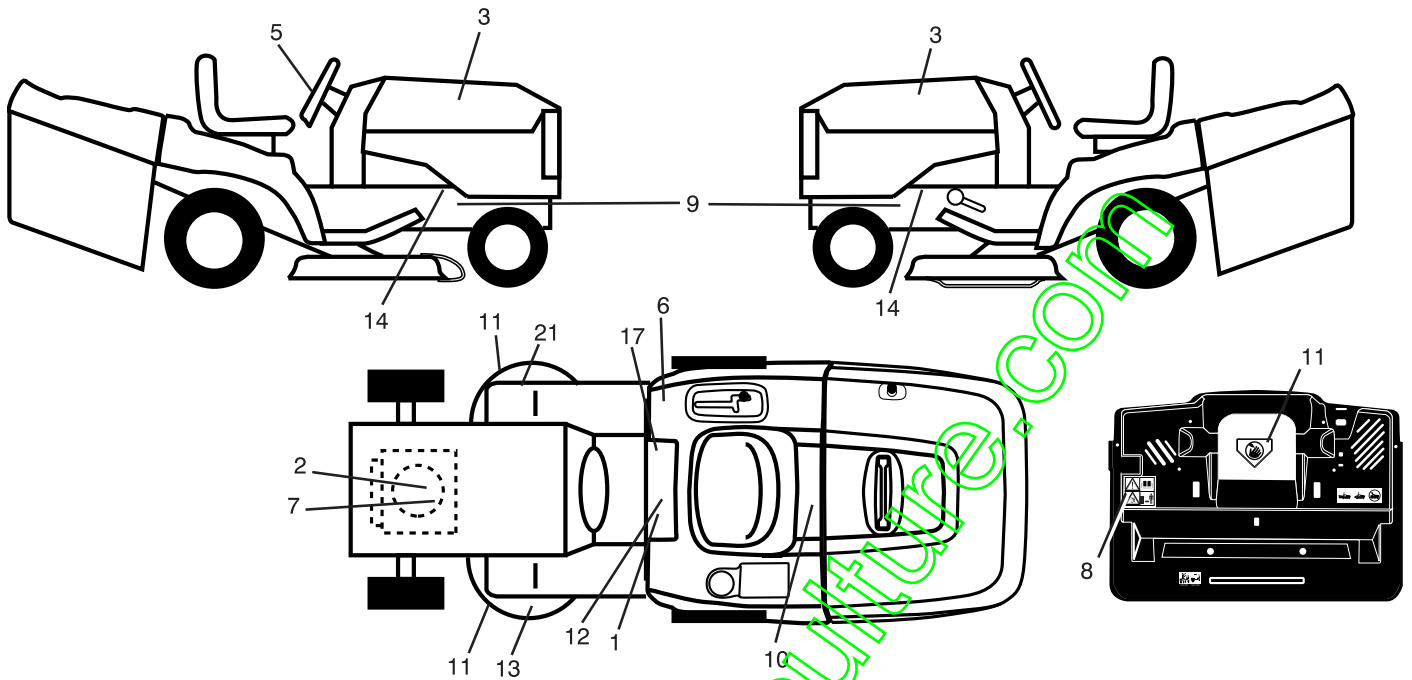

KEY NO.	PART NO.	DESCRIPTION
1	532 40 03-89	Decal Warning Sym CE
2	532 43 10-95	Decal Engine H.P.
3	532 43 24-60	Decal Hood RH/LH
5	532 43 24-76	Decal Steering Wheel
6	532 18 04-32	Decal 100 DBA/CE
7	532 19 68-41	Decal Warning Eng. Sym
8	532 18 04-35	Decal Rear Plate
9	532 40 11-46	Decal Warning Service Fire
10	532 14 50-05	Decal Bat Dan/Poi P/L Sym Wpn
11	532 18 21-66	Decal Mower Cut Finger Symbol
12	532 15 97-37	Decal Brake/Clutch Symbol Lt
13	532 18 78-11	Decal Enviro

KEY NO.	PART NO.	DESCRIPTION
14	532 15 97-36	Decal Chassis Hot Muffler
17	532 14 08-37	Decal Saddle Brake Parking
21	532 16 62-86	Decal Hex Belt Sch
--	532 16 69-60	Decal Bypass Fender CRD
--	532 13 83-11	Decal Lift Handle
--	532 18 10-90	Pad Footrest RH
--	532 18 10-91	Pad Footrest LH
--	532 43 16-92	Manual Operator's (Euro)
--	532 43 16-93	Manual Parts

WHEELS & TIRES

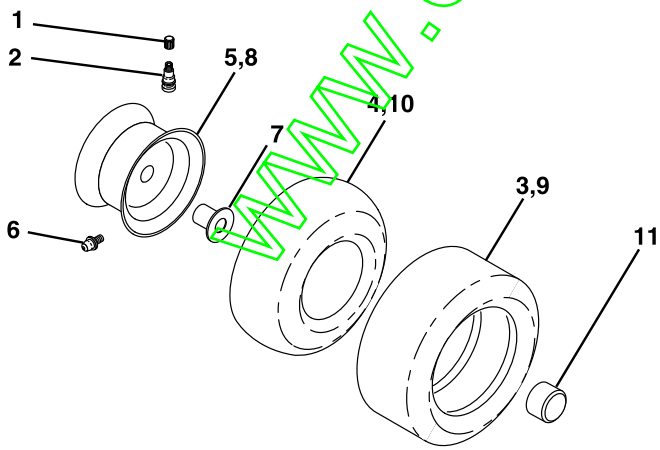

KEY NO.	PART NO.	DESCRIPTION
1	532 05 91-92	Cap Valve Tire
2	532 06 51-39	Stem Valve
3	532 10 62-22	Tire F Ts 15 x 6 0 - 6 Service
4	532 05 99-04	Tube Inner Front #35060
5	532 13 83-36	Rim Asm 6" Front Service
6	532 12 49-57	Fitting Grease
7	532 12 49-59	Bearing Flange
8	532 13 83-37	Rim Asm 8" Rear Service
9	532 13 84-68	Tire R Ts 20 x 8-8 Service
10	532 12 49-26	Tube Rear 9 5 x 8 Service
11	532 17 50-39	Cap Axle Blk 1 50 x 1 00
--	532 14 43-34	Sealant, Tire (10 oz. tube)

NOTE: All component dimensions given in U.S. inches
1 inch = 25.4 mm

**TRACTOR- -MODEL NO. BM155H107RBK (96061010605), PRODUCT NO. 960 61 01-06
ENGINE**

KEY NO.	PART NO.	DESCRIPTION
1	532 17 05-51	Control Throt Flag
2	817 72 04-08	Screw HEX THD Cut 1/4-20 X 1/2
3	-----	Engine B&S Model 31A607-1392-B1
4	532 13 73-52	Muffler Exhaust
8	532 17 18-77	Bolt
13	532 16 52-91	Gasket Muffler
23	532 16 98-37	Shield BRN/DBR Guard
25	532 19 06-95	Control Choke
29	532 13 71-80	Arrestor Spark
31	532 40 75-16	Tank Fuel Front
32	532 43 02-20	Cap Fuel Asm
33	532 12 34-87	Clamp Hose BLK
37	532 13 70-40	Line Fuel
40	532 12 40-28	Bushing
44	817 67 04-12	Screw Hexwsh THDROL 1/4-20 X 3/4
45	817 00 06-12	Screw 3/8-16 X 3/4
46	819 09 14-16	Washer 9/32 X 7/8 X 16 Ga.
72	532 19 23-34	Screw, 5/16-18 X .75
78	817 06 06-20	Screw 3/8-16 X 1-1/4
81	873 51 04-00	Nut Keps 1/4-20 unc
119	532 19 97-68	Guard Asm Engine LH CRD
120	532 19 97-67	Guard Asm Engine RH CRD
121	532 19 66-88	Clips Threaded
122	532 42 19-22	Extension Drain Oil
132	532 42 07-57	Shield Side RH
133	532 42 07-56	Shield Side LH
136	532 13 77-29	Screw THDROL 1/4 - 20 X 5/8

NOTE: All component dimensions given in U.S. inches
1 inch = 25.4 mm

Engine Power Rating Information

The gross power rating for individual gas engine models is labeled in accordance with SAE (Society of Automotive Engineers) code J1940 (Small Engine Power & Torque Rating Procedure), and rating performance has been obtained and corrected in accordance with SAE J1995 (Revision 2002-05). Torque values are derived at 3060 RPM; horsepower values are derived at 3600 RPM. Actual gross engine power will be lower and is affected by, among other things, ambient operating conditions and engine-to-engine variability. Given both the wide array of products on which engines are placed and the variety of environmental issues applicable to operating the equipment, the gas engine will not develop the rated gross power when used in a given piece of power equipment (actual "on-site" or net power). This difference is due to a variety of factors including, but not limited to, accessories (air cleaner, exhaust, charging, cooling, carburetor, fuel pump, etc.), application limitations, ambient operating conditions (temperature, humidity, altitude), and engine-to-engine variability. Due to manufacturing and capacity limitations, Briggs & Stratton may substitute an engine of higher rated power for this Series engine.

TRACTOR- -MODEL NO. BM155H107RBK (96061010605), PRODUCT NO. 960 61 01-06
MOWER

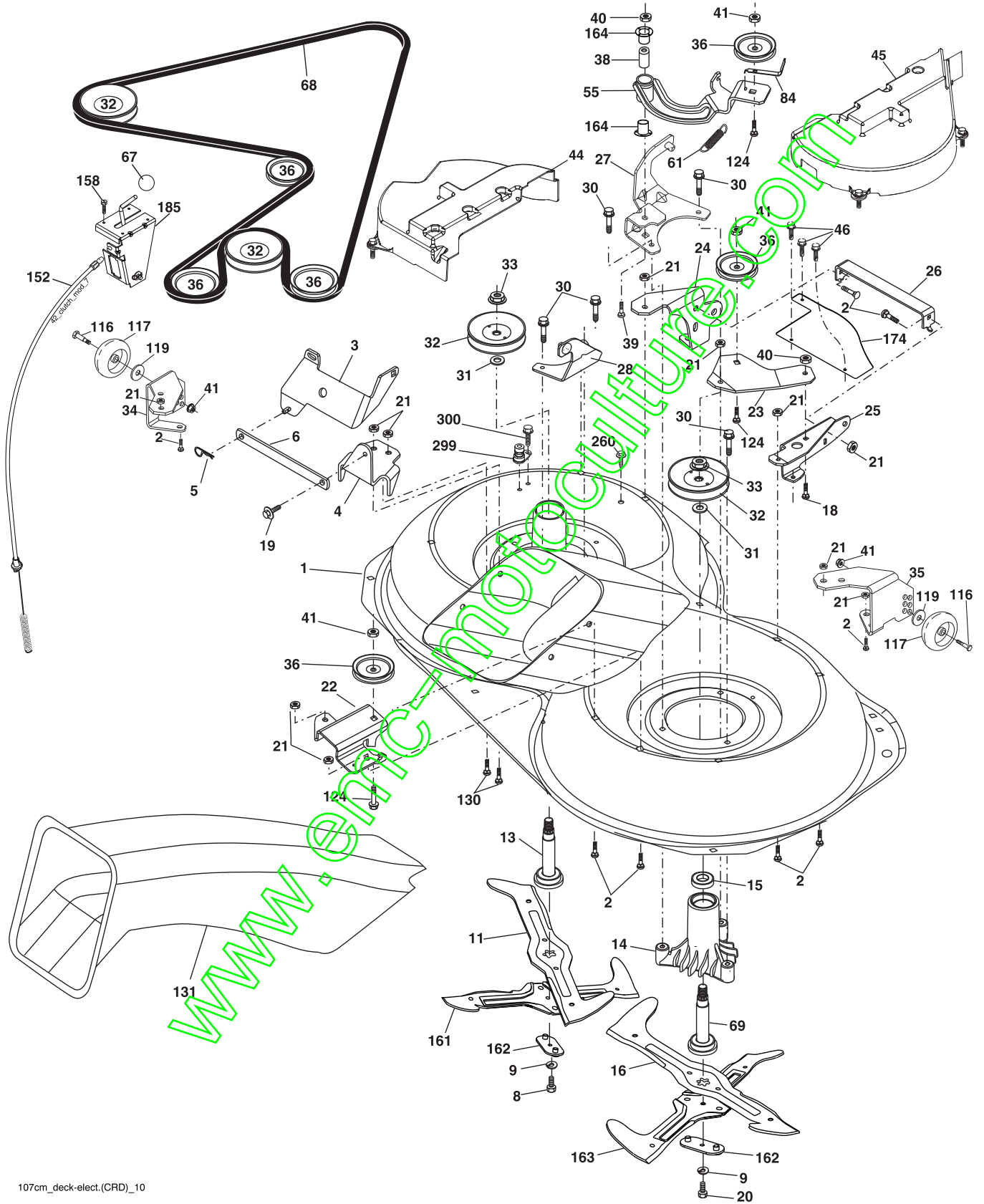

**TRACTOR- -MODEL NO. BM155H107RBK (96061010605), PRODUCT NO. 960 61 01-06
MOWER**

KEY NO.	PART NO.	DESCRIPTION	KEY NO.	PART NO.	DESCRIPTION
1	532 16 91-60	Housing Asm. Mower	46	532 13 77-29	Screw Thd Roll 1/4-20 x 5/8
2	872 14 05-06	Bolt Rdhd Sqnk 5/16-18 unc x 3/4	55	532 16 98-49	Arm Idler
3	532 43 18-64	Bracket Asm. S-Bar Chass	61	532 19 94-87	Spring Tension Belt
4	532 16 91-67	Bracket Bar Sway Deck	67	532 10 69-32	Knob
5	532 12 46-70	Retainer Spring	68	532 40 20-09	Hex Belt Mower
6	532 16 55-57	Bar Sway	69	532 16 54-82	Shaft Asm w/Lwr Brg RH Thd
8	532 18 17-12	Bolt 3/8-24 x 1.25 Gr. 8 Patched	84	532 15 60-85	Keeper Belt Idler
9	810 03 06-00	Washer Lock Hvy 3/8 Unplated	116	532 19 34-06	Bolt Shoulder
11	532 18 05-83	Blade 3-1 LH	117	532 17 48-73	Wheel Gauge
13	532 13 76-45	Shaft Asm. w/Lower Bearing	119	819 13 20-12	Washer 13/32 x 1-1/4 x 12 Ga.
14	532 12 87-74	Housing Mandrel Vented (Machd)	124	872 11 06-12	Bolt Carr Sh 3/8-16 x 1-1/2 Gr. 5
15	532 11 04-85	Bearing Ball Mandrel	130	872 11 06-06	Bolt Rdhdsqnk 5/16-18 unc x 3/4
16	532 18 05-84	Blade 3-1 RH	131	532 16 56-61	Chute Bagger CRD 92cm
18	872 11 06-06	Bolt Rdhd Sqnk 3/8-16 x 3/4 Gr. 5	152	532 17 60-74	Cable Clutch
19	532 13 28-27	Bolt Shoulder 5/16-18 Thd Form	158	817 72 04-08	Screw 1/4-20 x 1/2
20	532 18 17-13	Bolt 3/8-24 x 1.25 Gr. 8 Ptch	161	532 18 04-24	Blade Cross LH 107
21	873 68 05-00	Nut Crown Lock 5/16-18	162	532 18 08-78	Adapter Weldment Blade 107
22	532 16 91-65	Bracket Idler Sprt RR	163	532 18 04-25	Blade Cross RH 107
23	532 16 91-66	Bracket Idler Sprt RF	164	532 12 49-37	Bearing
24	532 41 34-36	Bracket Suspension LF	173	873 80 06-00	Nut Lock Hex w/INS 3/8-16 unc
25	532 40 01-05	Bracket Suspension RF	174	532 40 02-40	Guard Susp Front
26	532 40 01-10	Brace Susp Frt CRD	185	532 18 82-34	Head Asm Cable Clutch
27	532 16 91-72	Bracket Asm. Susp RR	260	817 67 06-08	Screw Rhdrol 3/8-16 x 1/2
28	532 16 91-68	Bracket Asm. Susp LR	---	532 18 18-57	Mandrel Assembly (Includes hous- ing, shaft assembly, and bearing only - pulley/nut/washer and blade bolt/washers not included)
30	532 17 39-84	Screw Thd Rolling Dod.PT Hex	---	532 18 18-58	Mandrel Asm CRD LH Threads
31	532 18 76-90	Washer Spacer Mower Vented	---	532 43 17-83	Replacement Mower Complete
32	532 19 81-45	Mandrel Pulleys			
33	532 40 02-34	Nut Flg Top Lock			
34	532 40 01-03	Bracket Gauge Wheel LF			
35	532 40 01-04	Bracket Gauge Wheel RF			
36	532 14 67-63	Pulley Idler V-Groove Dim 4.25			
38	532 16 98-51	Spacer Hub Arm Idler			
39	872 11 06-22	Bolt RhHd 3/8-16 unc x 2-3/4 Gr. 5			
40	873 68 06-00	Nut Crownlock 3/8-16 unc			
41	873 90 06-00	Nut Flangelock 3/8-16 unc			
44	532 43 24-04	Cover Mandrel LH			
45	532 43 24-05	Cover Mandrel RH			

NOTE: All component dimensions given in U.S. inches
1 inch = 25.4 mm

**TRACTOR- -MODEL NO. BM155H107RBK (96061010605), PRODUCT NO. 960 61 01-06
MOWER LIFT**

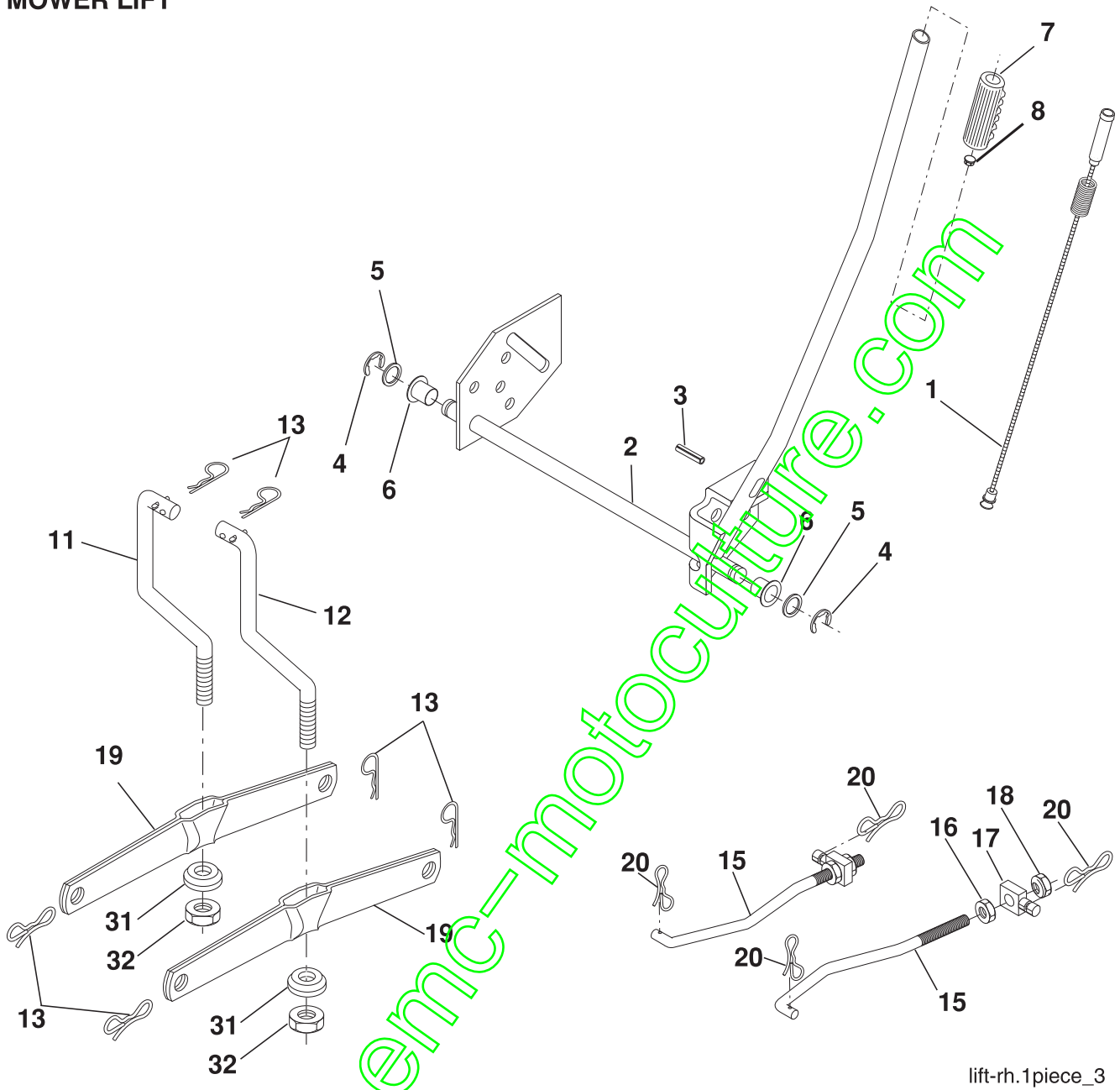

lift-rh.1piece_3

KEY NO.	PART NO.	DESCRIPTION
1	532 40 50-07	Plunger Asm. Lift Lever
2	532 19 80-70	Shaft Asm. Lift
3	532 18 88-22	Pin Groove
4	812 00 00-02	E Ring #5133-62
5	819 21 16-21	Washer 21/32 x 1 x 21 Ga.
6	532 12 01-83	Bearing Nylon
7	532 10 94-13	Grip Handle
8	532 12 45-26	Button Plunger
11	532 16 58-29	Link Asm Lift LH
12	532 16 58-31	Link Asm Lift RH
13	532 12 46-70	Retainer Spring

KEY NO.	PART NO.	DESCRIPTION
15	532 17 32-88	Link Front
16	873 35 08-00	Nut Jam Hex 1/2-13 unc
17	532 17 56-89	Trunnion Blk Zinc
18	873 80 08-00	Nut Lock w/wsh 1/2-13 unc
19	532 13 98-68	Arm Suspension Mower
20	532 19 42-09	Pin Cotter 7/16 Bow Tie Lock
31	532 16 98-65	Bearing, Pvt. Lift.
32	873 54 06-00	Nut Crownlock 3/8-24

NOTE: All component dimensions given in U.S. inches
1 inch = 25.4 mm

**TRACTOR- -MODEL NO. BM155H107RBK (96061010605), PRODUCT NO. 960 61 01-06
BAGGER**

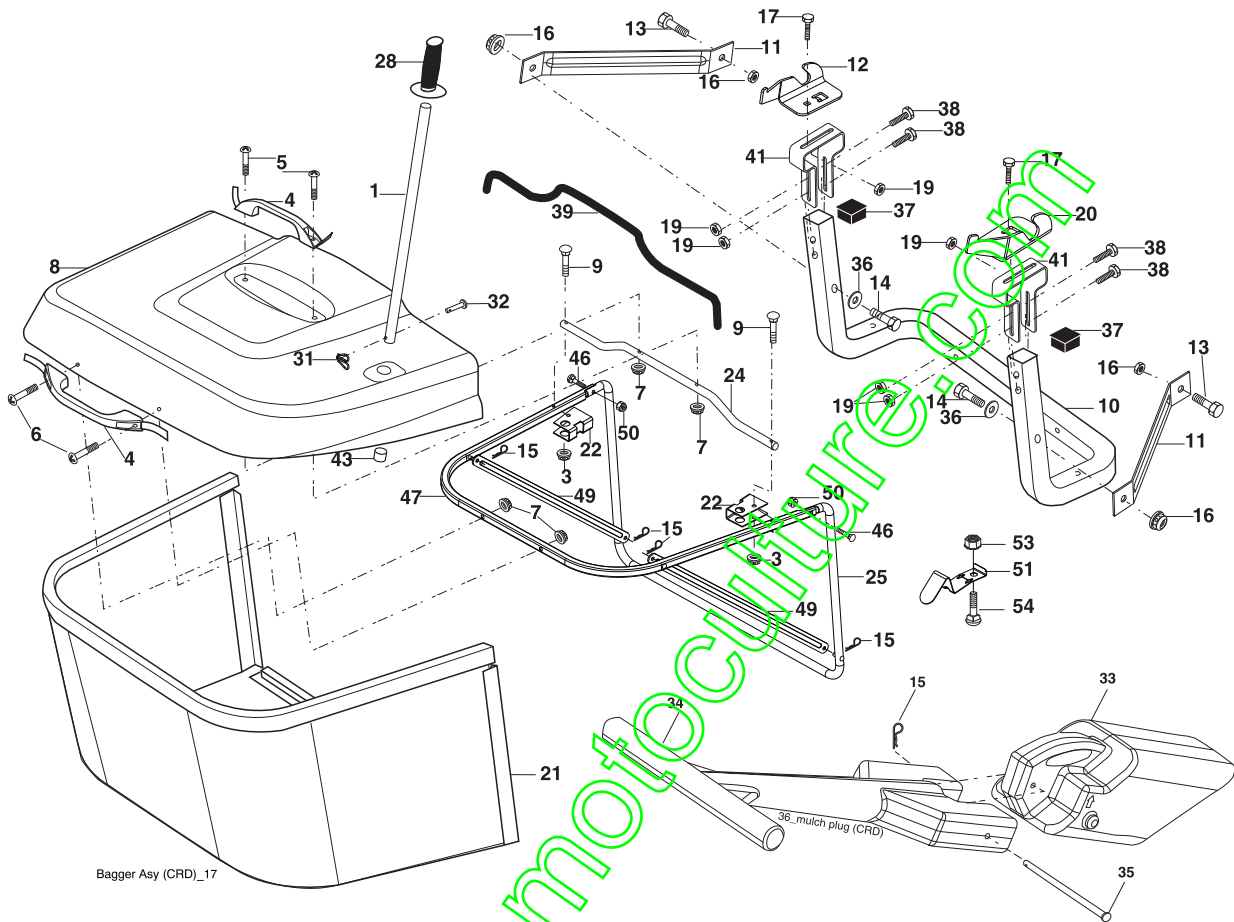

Bagger Assy (CRD)_17

KEY NO.	PART NO.	DESCRIPTION	KEY NO.	PART NO.	DESCRIPTION
1	532 42 86-10	Tube Handle Bagger CRD	28	532 16 57-87	Grip Handle
3	532 12 39-76	Nut Lock 1/4 Lge Fig Gr. 5 Zinc	31	532 16 94-84	Retainer Clip
4	532 16 99-16	Handle Bagger w/Lyrs Blk CRD	32	532 12 68-75	Rivet Rd Hd Drilled 3/8 Dia
5	874 98 10-24	Screw Pan Head #10-24 x 1.50	33	532 42 86-83	Plug Mulcher
6	874 98 10-32	Screw Pan Hd	34	532 16 55-70	Handle Mulcher
7	873 40 10-00	Nut Wiz Lock Hex Serr/Hd 10-24	35	532 16 55-72	Pin Mulcher
8	532 19 24-70	Cover Bagger	36	819 13 20-12	Washer 13/32 x 1-1/4 x 12 Ga.
9	872 14 04-18	Bolt Carriage 1/4-20 x 2.25d x Gr. 5	37	532 17 54-01	Plug Support Bagger CRD
10	532 18 12-82	Tube Support Bagger CRD	38	872 01 05-20	Bolt 5/16-18 x 2-1/2
11	532 16 57-19	Bracket Support Upper Bag CRD	39	532 41 62-57	Seal
12	532 18 88-48	Bracket Pivot LH	41	532 16 96-83	Bracket Pnt Adj Pvt Bagger CRD
13	874 76 06-12	Bolt Pin Hex 3/8-16 unc x 3/4	43	532 17 40-83	Plug Tubing End
14	874 52 06-36	Bolt Fin Hex 3/8-16 x 2-1/4 Gr. 5	46	872 11 05-10	Bolt 5/16-18 x 1-1/4
15	532 12 46-70	Retainer Spring	47	532 19 37-04	Tube Upper Bagger
16	873 90 06-00	Nut Lock 3/8-16 unc	49	532 19 33-05	Bar Spreader
17	872 14 05-06	Bolt Rdhd Sht Sqnk 5/16-18 unc x 3/4	50	873 80 05-00	Nut 5/16-18
19	873 90 05-00	Nut Lock Hex Flange 5/16-18	51	532 19 99-03	Latch Spring Bagger
20	532 18 88-47	Bracket Pivot RH	53	873 51 04-00	Nut 1/4-20 unc
21	532 40 61-80	Bag Asm CRD	54	872 14 04-06	Bolt 1/4-20 x 3/4 Gr. 5
22	532 16 57-81	Bracket Side Bagger CRD			
24	532 16 57-83	Tube Pivot Bagger CRD			
25	532 19 37-05	Tube Front			

NOTE: All component dimensions given in U.S. inches
1 inch = 25.4 mm

www.emc-motoculture.com

BESTGREEN