

20" REAR BAGGER ROTARY MOWER MODEL NO. BM2D779B

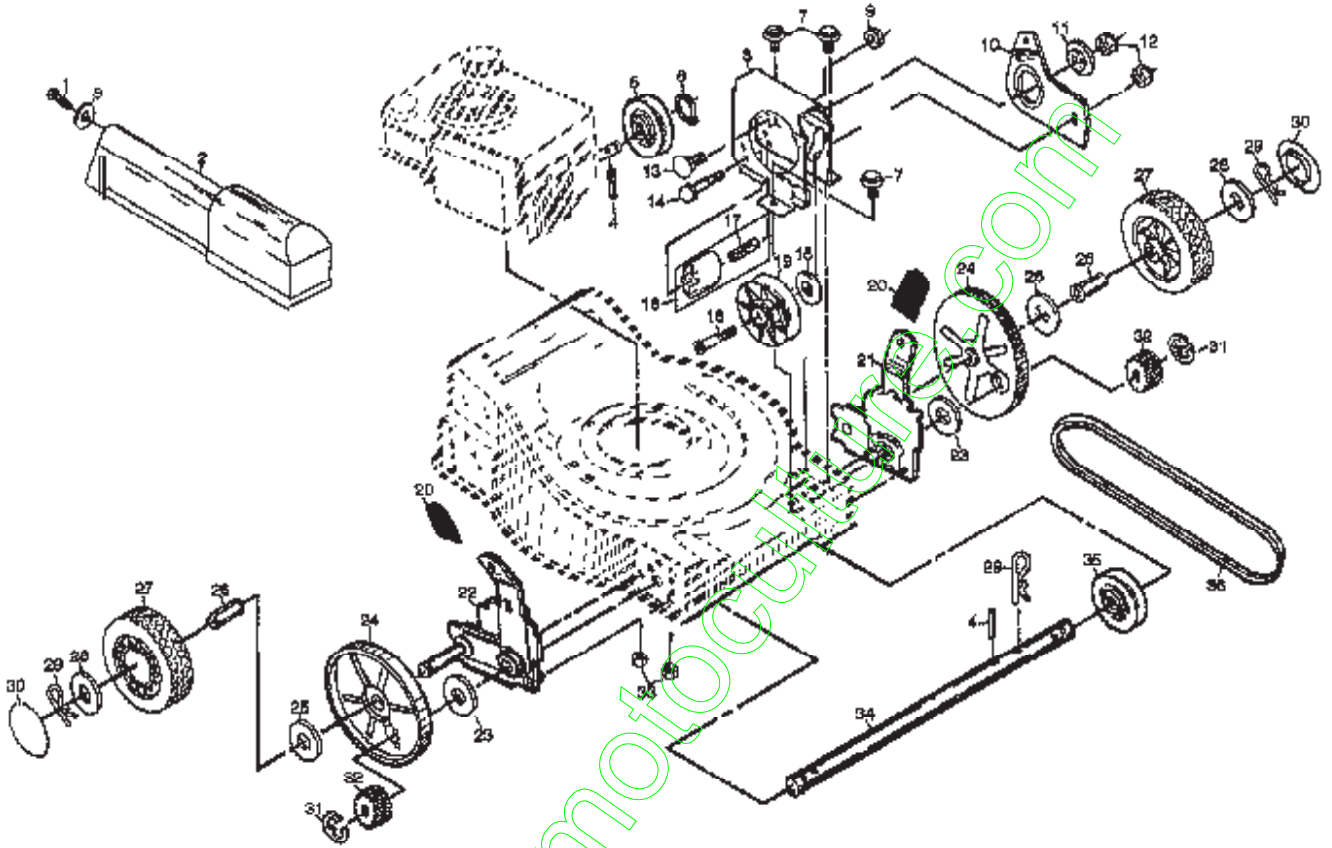

Ref #	Part Number	Qty	Description
1	750097		TAPPING SCREW
2	750727		DRIVE CVR
3	4802		SUB= 19070818
4	851980		DRIVE PAWL
5	88043		PULLEY PM
6	12000030		RETAINING RING ST
7	54583		SCREW
8	851947X004		"CLUTCH,FRAME"
9	50962		LOCKNUT
10	88065X004		SUB= 702631X004
11	88067		SPACER PM
12	750253		LOCKNUT
13	72070504		CARRIAGE BOLT
14	74350424		BOLT 1/4-20-1 1/2
15	88069		SPACER PM
16	48160		IDLER ASSY
17	88576		IDLER SPACER
18	88517		SHOULDER BOLT
19	88516		IDLER PULLEY
20	87877		KNOB PM
21	700339		SUB= 151228
22	700340		SUB= 151226
23	88118		WASHER PM
24	88080		DUST SHROUD PM
25	67725		WASHER FLUT
26	88446		BUSHING.HEX
27	700953		WHEEL.8X2.LP.PR
28	52160		WASHER
29	85179		RETAINER CLIP PM
30	77400		HUB CAP
31	12000057		SUB= 12000058
32	137054		PINION.GEAR
33	63601		SUB= 73800400
34	700537		SHAFT.DRIVE.17.81
35	88082		DRIVE PULLEY PM
36	850053		"DRIVE, BELT"
	146207		SHEET.SYM.BESTGRE

www.emc-motors.com

20" REAR BAGGER ROTARY MOWER MODEL NO. BM2D779B

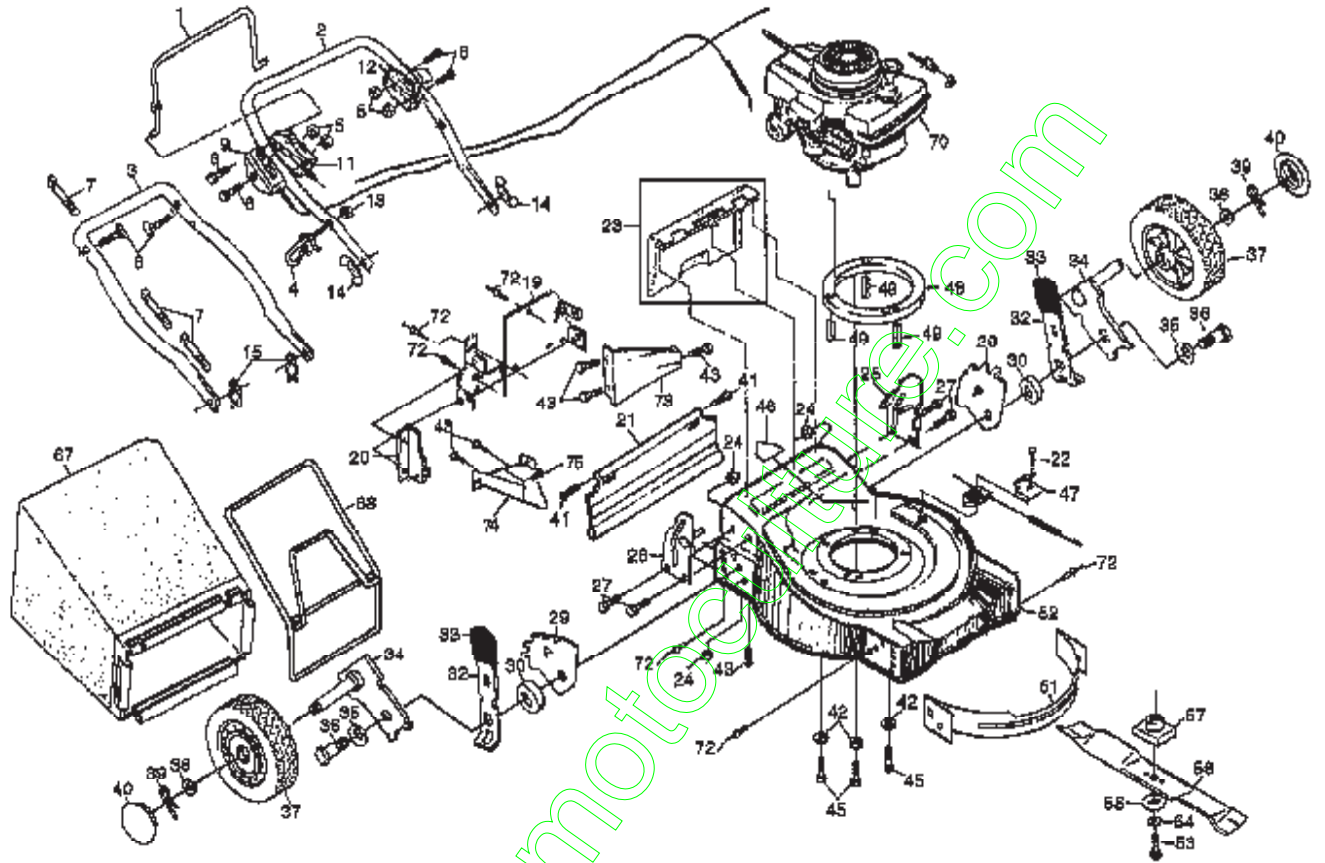

www.emc-motors.com

Ref #	Part Number	Qty	Description
1	133006		CONTROL BAR
2	132670X479		SUB= 154480X479
3	134081X479		SUB= 151590X479
4	132001		ROPE GUIDE
5	63601		SUB= 73800400
6	131959		BOLT.HANDLE.LM
7	66426		SUB= 7192J
8	144929		SCREW.HXHD.WASH.
9	127244X		THROTTLE CONTROL
11	144025		CABLE MZR E/S
12	133879		DRIVE CONTROL
13	73510400		NUT
14	128638		"NUT,WING PM"
15	51793		HAIRPIN COTTER
19	700355X419		SUB= 700355X479
20	700363X419		SUB= 700363X479
21	140657		SKIRT.PUSH.20RD
22	85768		"SCREW, HEX PM"
23	48257		"KIT, REAR DOOR PM"
24	751592		LOCKNUT PM
25	700913X479		SUB= 150956
26	700915X479		SUB= 150956
27	55187		SCREW
29	700375		SUB= 700325X007
30	84920		SUB= 146630
32	700331X004		SPRING SELECTOR
33	87877		KNOB PM
34	85021X004		AXLE ARM
35	62335		"WASHER, BELLEVIL."
36	84921		SUB= 142748
37	700953		WHEEL.8X2.LP.PR
38	52160		WASHER
39	85179		RETAINER CLIP PM
40	77400		HUB CAP
41	88652		HINGE SCREW
42	53998		SUB= 19131216
43	54583		SCREW
45	850999		SCREW
46	145494		DECAL.DANGER.CUTF
47	88615		BRKT DRV COV
48	850988		ENGINE SPACER
49	850987		SUB= 850988
51	132198X479		SUB= 144961
52	146297		KIT.HSG.20RD.FWBD
53	851084		SCREW
54	850263		LOCKWASHER
55	851074		"WASHER,HARDEN"
56	850972		BLADE.STAND.20INC
57	851514		ADAPTOR.BLADE.LM
67	134559		SUB= 149597
68	133413		CATCHER FRAME
70			CHECK WITH SUPPLIER
72	128415		BLIND RIVET
73	700063X479		REAR BAFFLE
74	133188X479		DISCHARGE GUARD
75	86344		SCREW PM
	140755		MANUAL OPR GEN SP
	140756		NLA

Ref #	Part Number	Qty	Description
	145749		MANUAL.P.BM2D779B
	133414		HOUSING DECAL
	145495		DECAL.INTERN.4SYM
	MA36		CLIPPING DEFL
	MK20FRD		"KIT, MULCHER 20""

[www.emc-motoculture.com](http://www.emc-motoculture.com)

**20" REAR BAGGER ROTARY LAWN MOWER - - MODEL NO. BM2D779B**

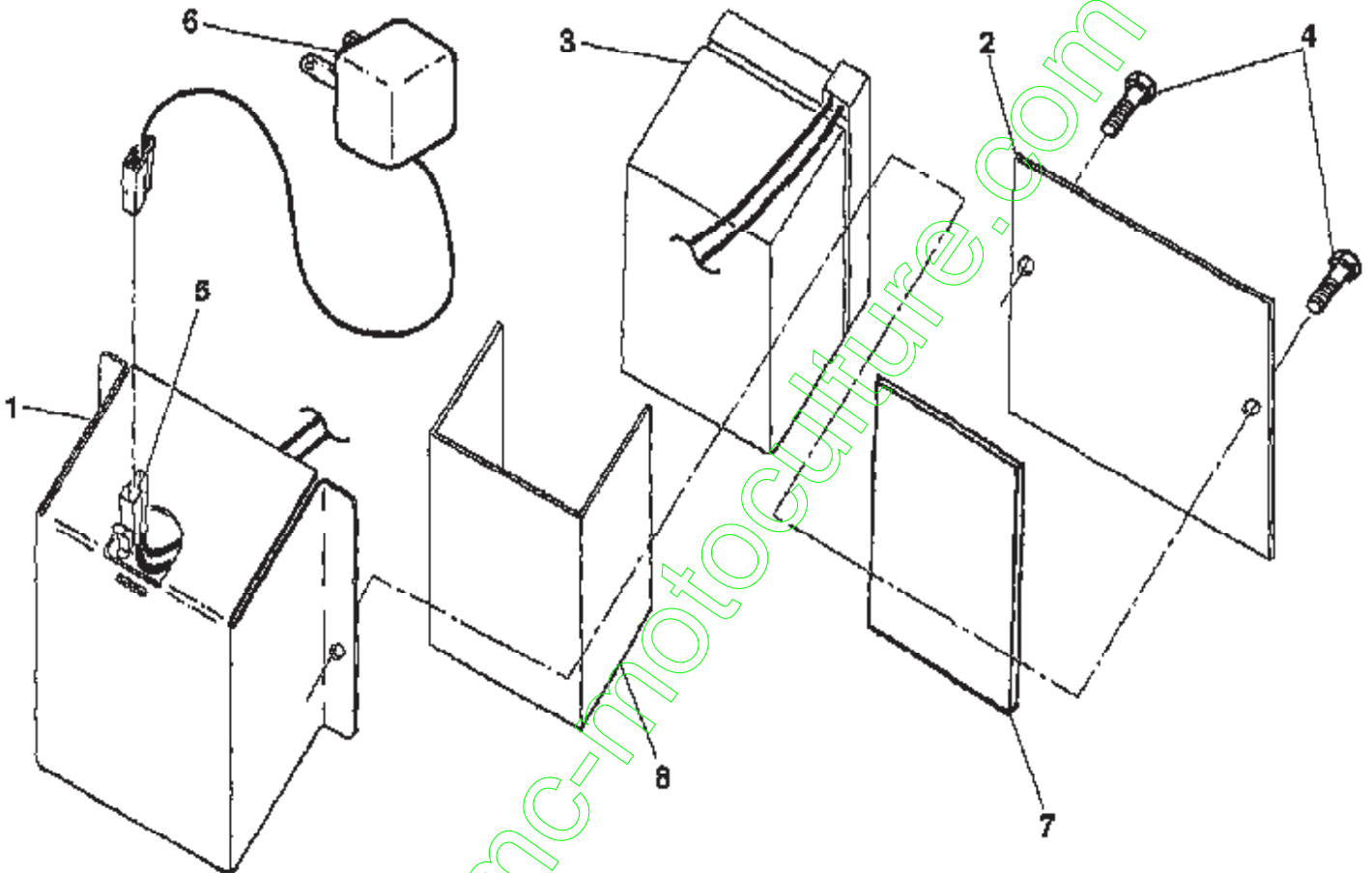

www.emc-motoculture.com

Ref #	Part Number	Qty	Description
1	86334X479		BRACKET.BATTERY
2	86337X479		COVER.BATTERY
3	750909		SUB= 48374
4	36953		SCREW SELF TAP
5	86353		CONNECTOR PM
6	130024		"CHARGER, BATTERY"
7	86649		"PAD PM, BATTERY"
8	134861		"WRAP, BATTERY"

[www.emc-motoculture.com](http://www.emc-motoculture.com)