

TRACTOR -- MODEL NUMBER CP10910A BRAKE / REAR MOWER LIFT ASSEMBLY

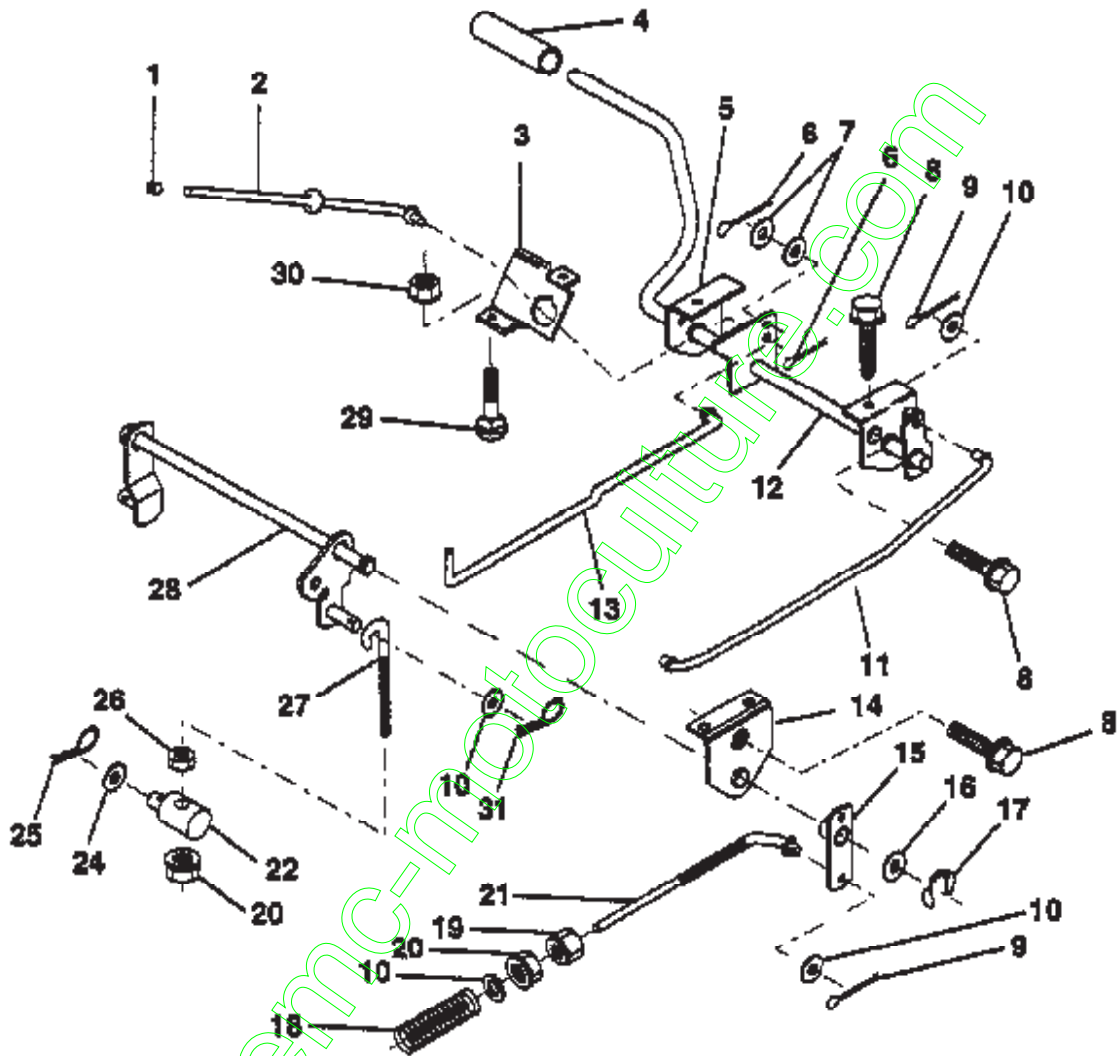

NOTE: All component dimensions given in U.S. inches.
1 inch = 25.4 mm.

Ref #	Part Number	Qty	Description
1	71673		PLUNGER CAP T
2	123436X		"ROD,PARK BRAKE"
3	123437X		"BRKT,PARK BRAKE"
4	8156H		FOOT PEDAL COVER
5	122504X		"BRKT,CLU PEDAL LH"
6	76020312		SUB= 3145
7	19131016		WASHER
8	17490508		SCREW LT
9	76020412		COTTER PIN
10	19131316		WASHER
11	123543X		"ROD,FRT BRAKE"
12	139933		PEDAL ASM CL/BK36
13	123394X		"ROD,CLUTCH"
14	121978X		"BRKT,LIFT SHAFT"
15	133332		PVT BRAKE ARM ASM
16	19251816		WASHER T
17	12000034		KLIP RING
18	106888X		SPRING ROD LT
19	73350600		NUT
20	73680600		SUB= 73690600
21	131460		SUB= 532131460
22	144585		TRUNNION.LIFT.
24	19132012		WASHER
25	4921H		SPRING.RETAINER
26	73930600		LOCKNUT
27	127369		"LINK, MOWER REAR"
28	140776		LIFT ASM MOW REAR
29	72110506		SUB= 72270506
30	73510500		NUT
31	3146R		RETAINER.SPRING

www.emc-motors.com

TRACTOR - - MODEL NUMBER CP10910A

DASH

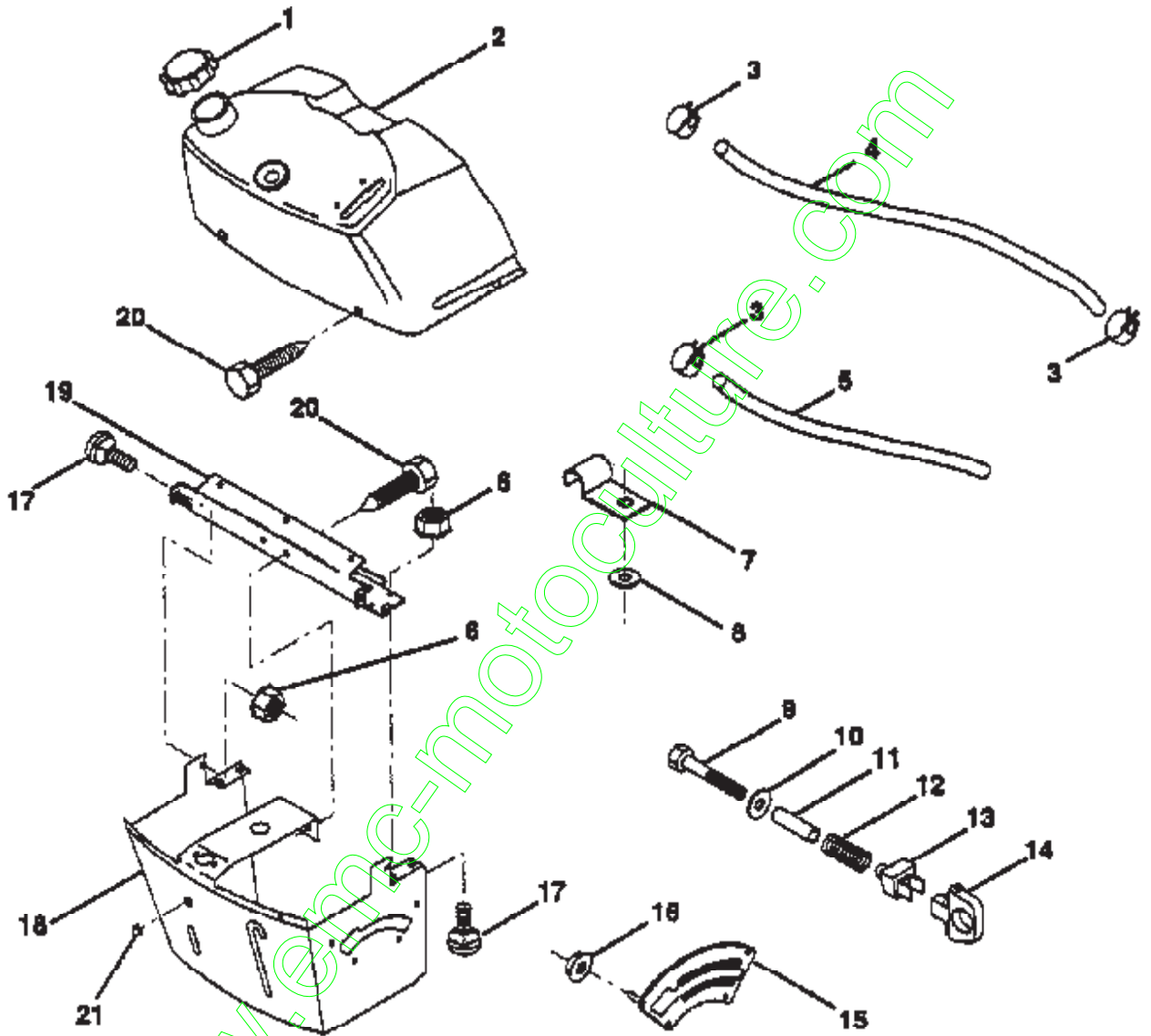

NOTE: All component dimensions given in U.S. inches.
1 inch = 25.4 mm.

Ref #	Part Number	Qty	Description
1	141523		CAP BLK FUEL LR
2	138393		TANK.ASM.DASH.LR
3	123487X		HOSE CLAMP
4	8544R		SUB= 295J
5	8548R		FUEL LINE T
6	73640400		NUT HXKEP 1/4X20
7	2751R		CLIP T
8	19091216		WASHER PM
9	74760428		BOLT
10	19091413		WASHER
11	121249X		SPACER SPLIT
12	3720R		SPRING M
13	126450X		"KNOB,HGT RETAINER"
14	126115X		KNOB
15	122023X		ADJUSTER QUAD
16	124346X		NUT
17	72110404		BOLT
18	130745		SUPT ASSY DASH
19	134744		CROSS BRACE
20	17060408		SCREW 1/4-20X1/2
21	134014		PLUG DOME

www.emc-motoculture.com

TRACTOR - - MODEL NUMBER CP10910A

DECALS

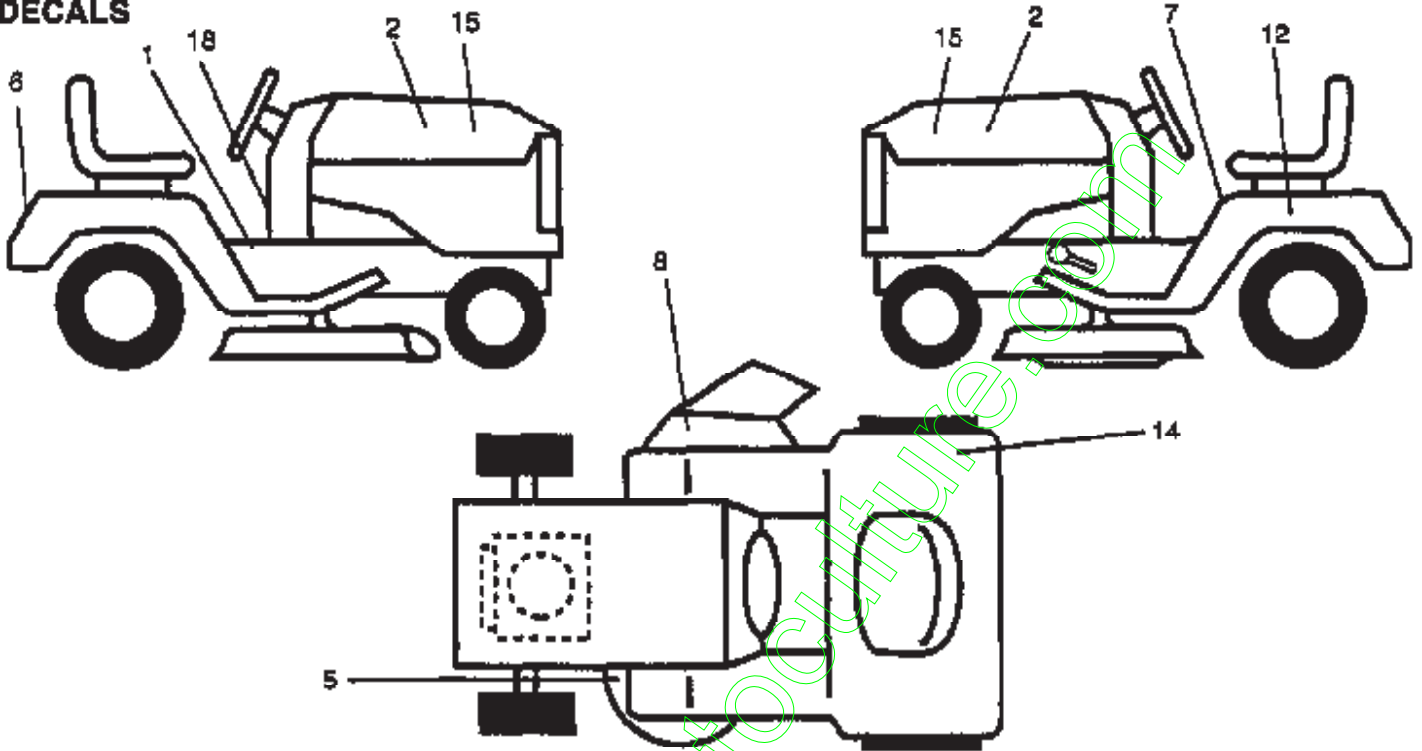

www.emc-motortune.com

Ref #	Part Number	Qty	Description
1	145545		DECAL.OP.INST.SYM
2	148420		DECAL.HD.RH/LH.CP
5	136830		DECAL.V.BELT
6	148422		DECAL.FENDER.CP
7	145498		DECAL.READ.O.MANU
8	145494		DECAL.DANGER.CUTF
12	145005		DECAL.BATRY.3-3908
14	125690X		DECAL
15	148421		DECAL.PNL.SD.CP
18	145437		DECAL.EURO.ST.CE.
	138311		DECAL HANDLE LIFT
	147061		MANUAL.OP.ENGLISH
	146974		MANUAL.OP.GEN.LR.
	147847		MANUAL.P.CP10910A
	C36		REAR BAGGER
	MK36		MULCHER KIT

www.emc-motoculture.com

TRACTOR -- MODEL NUMBER CP10910A

ELECTRICAL

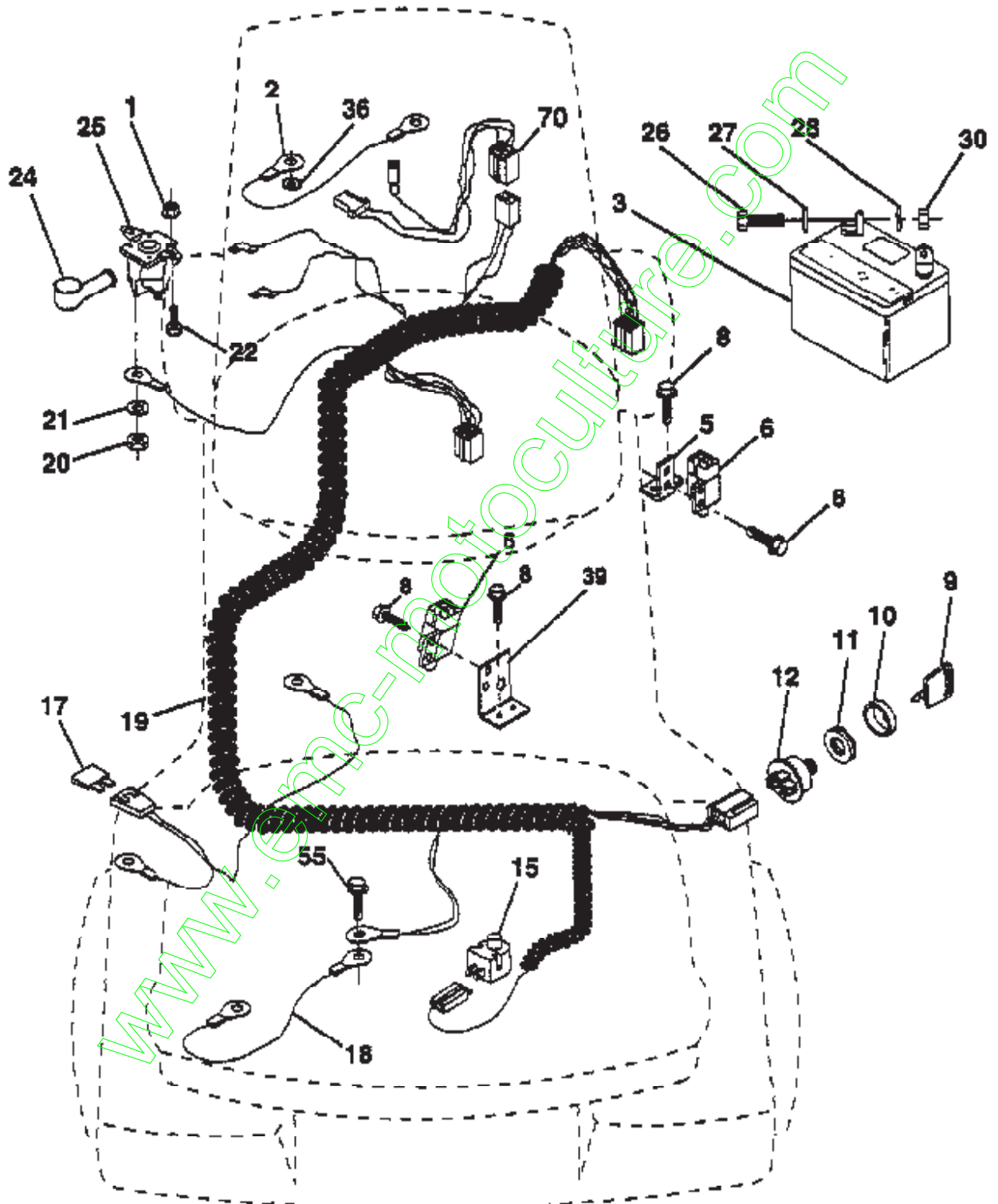

Ref #	Part Number	Qty	Description
1	73640400		NUT HXKEP 1/4X20
2	108423X		CABLE ASM.
3	144924		SUB= 123899X
5	108236X		BRACKET LT
6	109553X		SWITCH INTERLOCKT
8	17021008		SCREW
9	140402		KEY STEEL DELTA
10	141226		COVER KEY SWITCH
11	140400		SUB= 145774
12	144921		SUB= 163088
15	121305X		SWITCH SEAT
17	108824X		FUSE HYT
18	128353		CABLE ASSY
19	146063		HARNES.SIGN.FEND.
20	73350400		NUT
21	10090400		SUB= 10040400
22	71110408		BOLT HXHD.FIN
24	131563		SUB= 154336
25	145673		SUB= 146154
26	74760412		BOLT LT
27	19091016		WASHER
28	10040400		LOCKWASHER
30	73220400		SUB= 50675
36	11150400		LOCKWASHER
39	141735		BRACKET SWT CLUTC
55	17490508		SCREW LT
70	140413		HARNES ENG DUAL

www.emc-motors.com

TRACTOR - - MODEL NUMBER CP10910A

ENGINE / THROTTLE

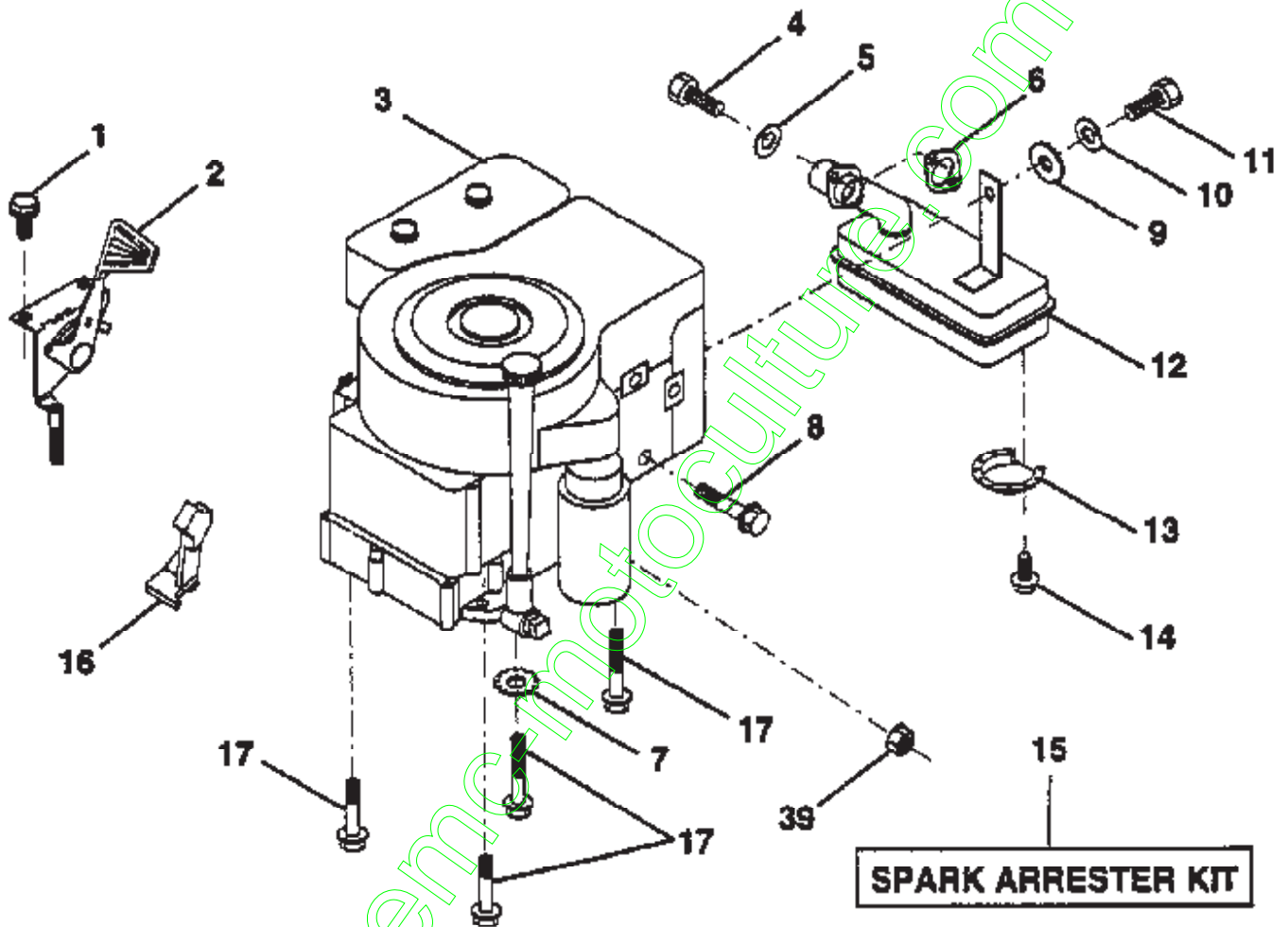

NOTE: All component dimensions given in U.S. inches.
1 inch = 25.4 mm

Ref #	Part Number	Qty	Description
1	17060408		SCREW.1/4-20X1/2
2	133025		SUB= 532133025
3	145292		ENGINE
4	71070512		SCREW
5	10040500		LOCKWASHER
6	125593X		SUB= 272293
7	11050600		LOCKWASHER
8	121094X		BOLT T
9	19101216		WASHER
10	10040400		LOCKWASHER
11	74760412		BOLT LT
12	137437		MUFFLER
13	101326L		DEFLECTOR.222573
14	17030808		SUB= 17030814
15	137180		SUB= 532137180
16	127951		"STOP,DASH THROTT"
17	17490624		SCREW LT
39	73510400		NUT

www.emc-motoculture.com

TRACTOR -- MODEL NUMBER CP10910A

FENDER / CHASSIS

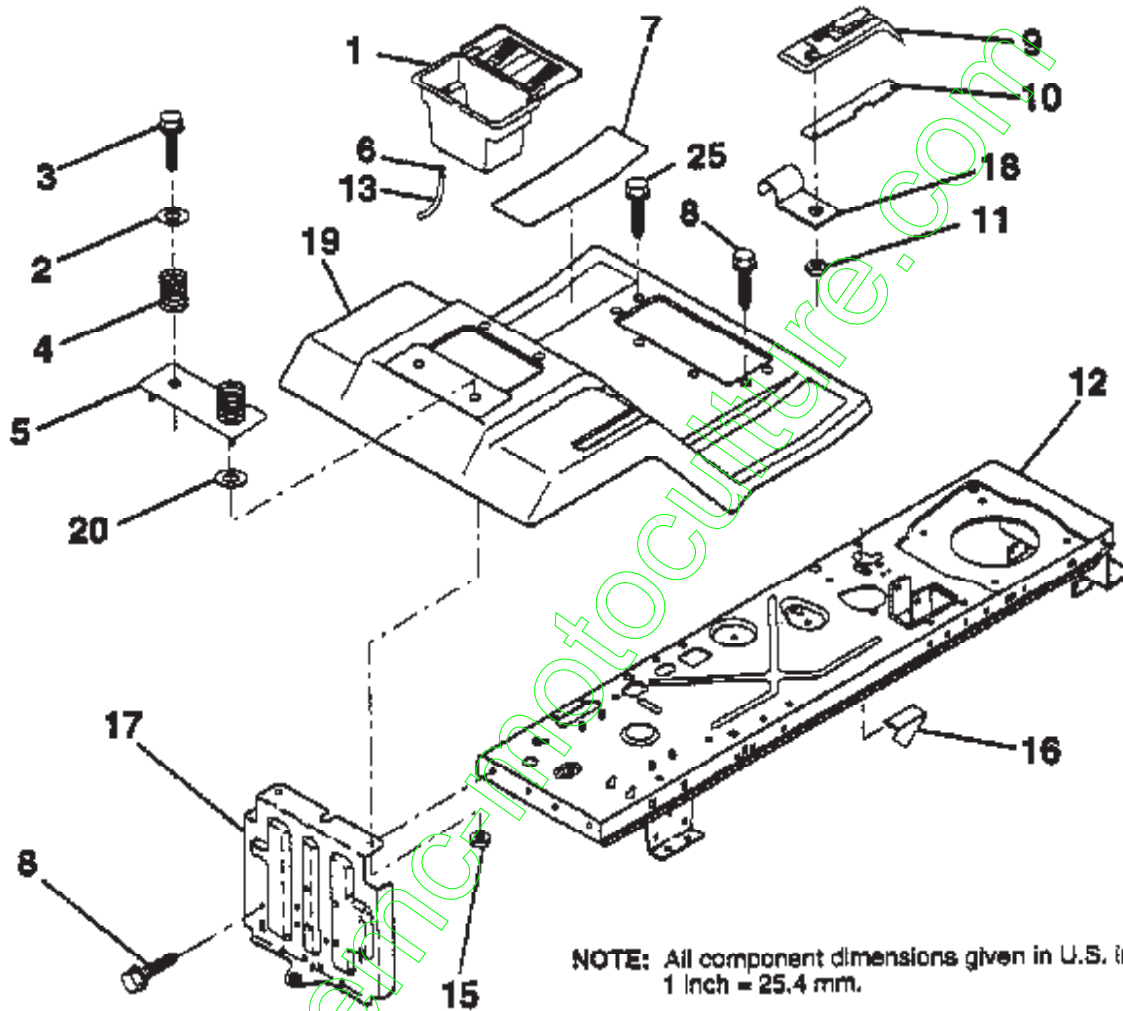

NOTE: All component dimensions given in U.S. inches.
1 inch = 25.4 mm.

Ref #	Part Number	Qty	Description
1	129965		SUB= 156417
2	19132012		WASHER
3	17490612		SCREW
4	124181X		SPRING COMPRESSIO
5	127115X505		BTRY FENDER PLATE
6	109596X		HOSE CLAMP T
7	124144X		PAD FOOTREST
8	17490512		SCREW
9	126993X		CONSOLE SHFT 4SP
10	139783		PLATE LOCK SHIFT
11	124346X		NUT
12	145190		CHASSIS.WELD.ASM.
13	109238X		TUBE T
15	73640600		NUT 1/4-20
16	141736		SUB= 146613
17	140782		DRAWBAR ASM LR
18	126470X		"CLIP,INSULATOR"
19	140955X505		FENDER/FOOT MS505
20	19091413		WASHER
25	17190516		SCREW

www.emc-motoculturas.com

TRACTOR -- MODEL NUMBER CP10910A

FRONT AXLE

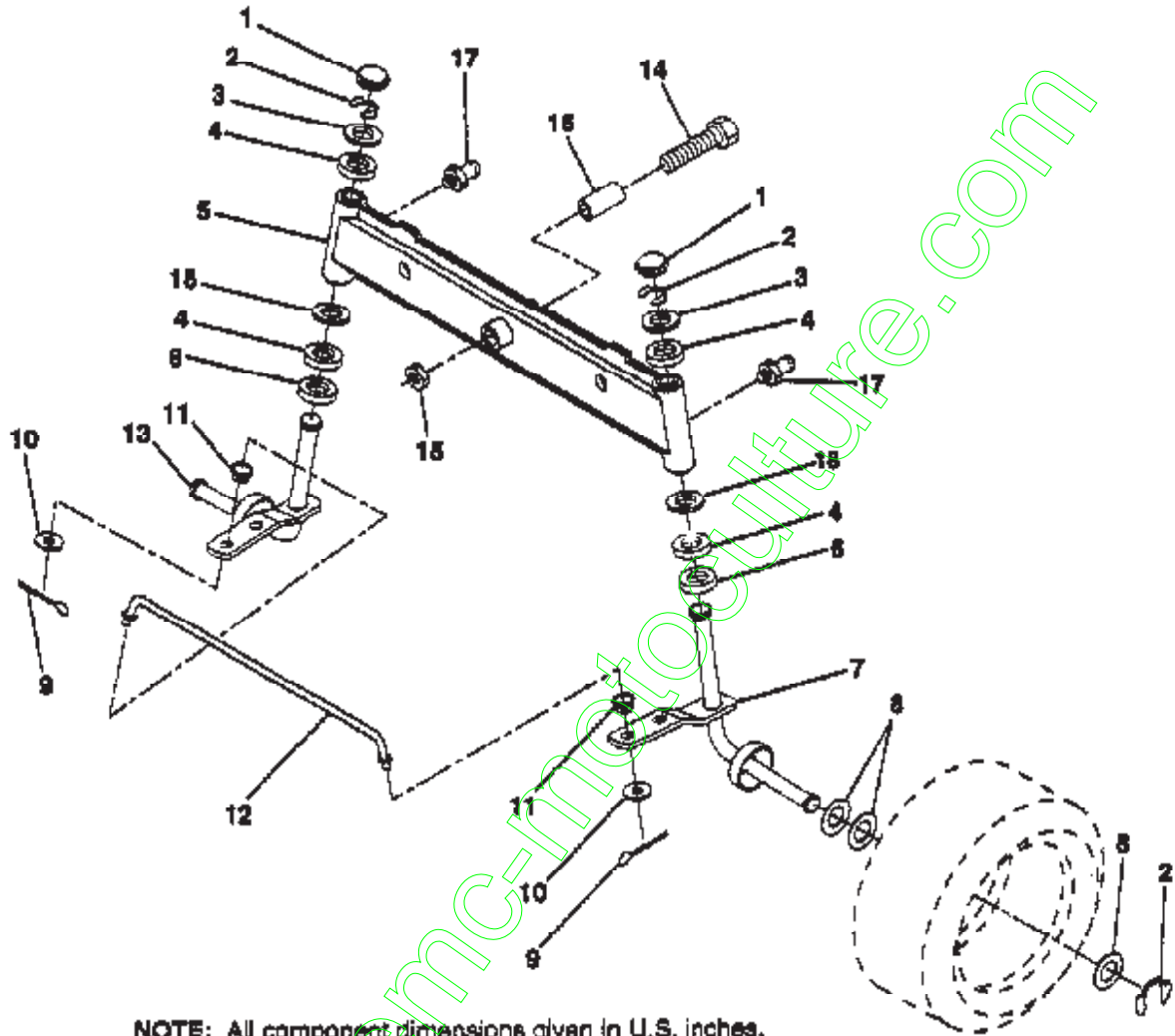

NOTE: All component dimensions given in U.S. inches.
1 inch = 25.4 mm.

Ref #	Part Number	Qty	Description
1	121232X		CAP
2	12000029		RING
3	121748X		WASHER
4	3366R		COL. SRTG. BEAR.
5	142033		AXLE ASM FRONT
6	6266H		WASHER .T
7	137062		SPINDLE ASM RH
8	121749X		WASHER
9	76020412		COTTER PIN
10	19131316		WASHER
11	126847X		BUSHING.DRAGLINK
12	130465		TIE ROD
13	137061		SPINDLE ASM LH
14	74011056		BOLT HEX 5/8-11
15	73901000		"NUT-LOC,FLANGE,LT"
16	110438X		BEARING
17	6855M		ZERK M
18	19272016		WASHER

www.emc-motoculture.com

TRACTOR -- MODEL NUMBER CP10910A

GROUND DRIVE

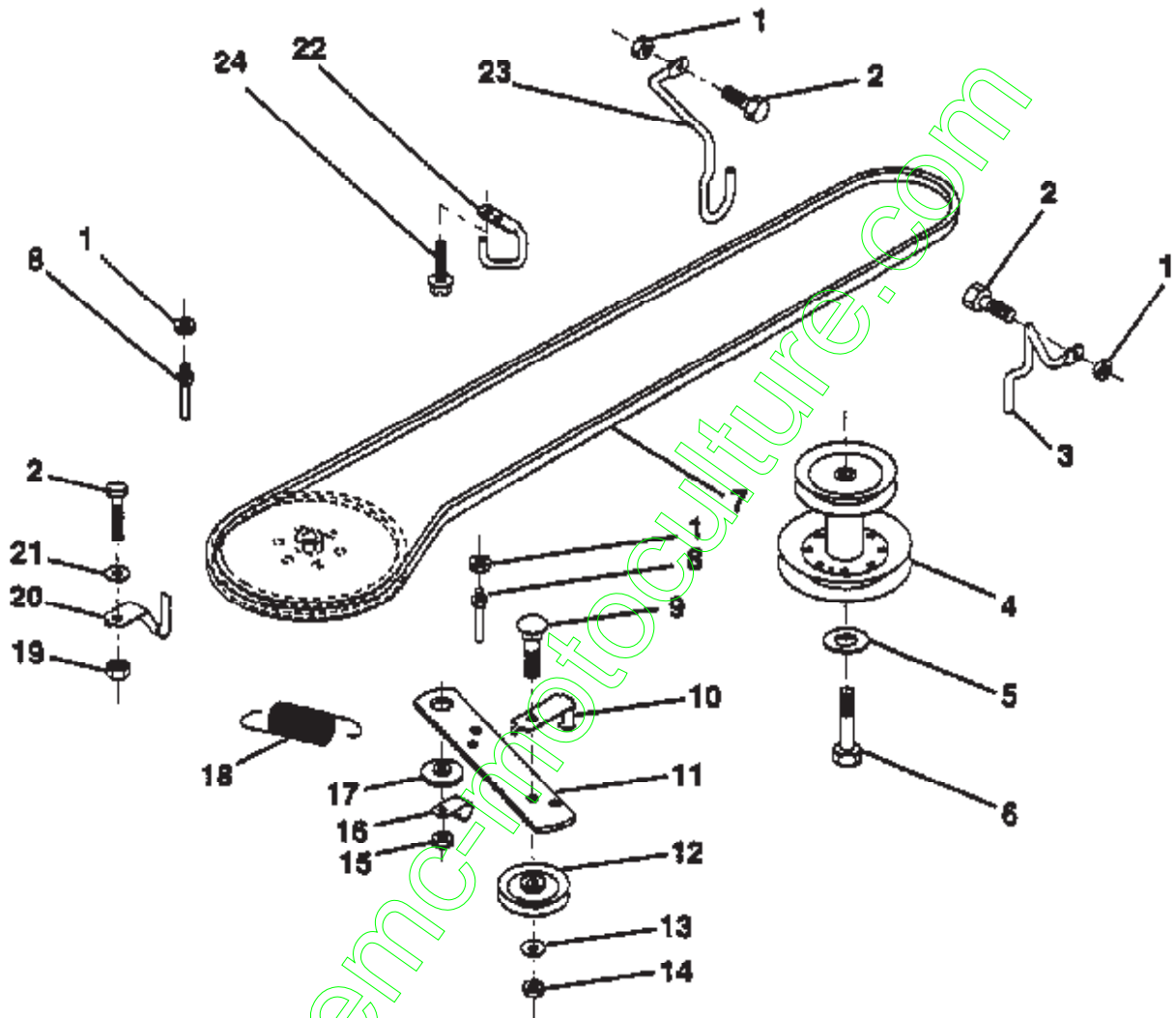

NOTE: All component dimensions given in U.S. inches.
1 inch = 25.4 mm

www.emc-photoculture.com

Ref #	Part Number	Qty	Description
1	73680500		SUB= 73690500
2	74760512		BOLT
3	141342		KEEPER RH
4	138029		PULLEY.ENGINE.LR
5	10040700		LOCKWASHER
6	71170744		HEX BOLT
7	124525X		BELT
8	123405X		"KEEPER,DRIVE BELT"
9	72140612		BOLT
10	123396X		"KEEP,IDLER DR BEL"
11	140911		ARM IDLER CLUT GD
12	123674X		PULLEY.IDLER.FLAT
13	19131316		WASHER
14	73930600		LOCKNUT
15	73680600		SUB= 73690600
16	126471X		"CLIP,INSULATOR"
17	122052X		SPACER RETAINER
18	131459		SUB= 532131459
19	73510500		NUT
20	139919		KEEPER.BELT.T/A
21	19111016		WASHER
22	123404X		"KEEPER,FRA DR BEL"
23	140916		KEEPER MOWER LH
24	17720408		SCREW

www.emc-motors.com

TRACTOR -- MODEL NUMBER CP10910A

HOOD

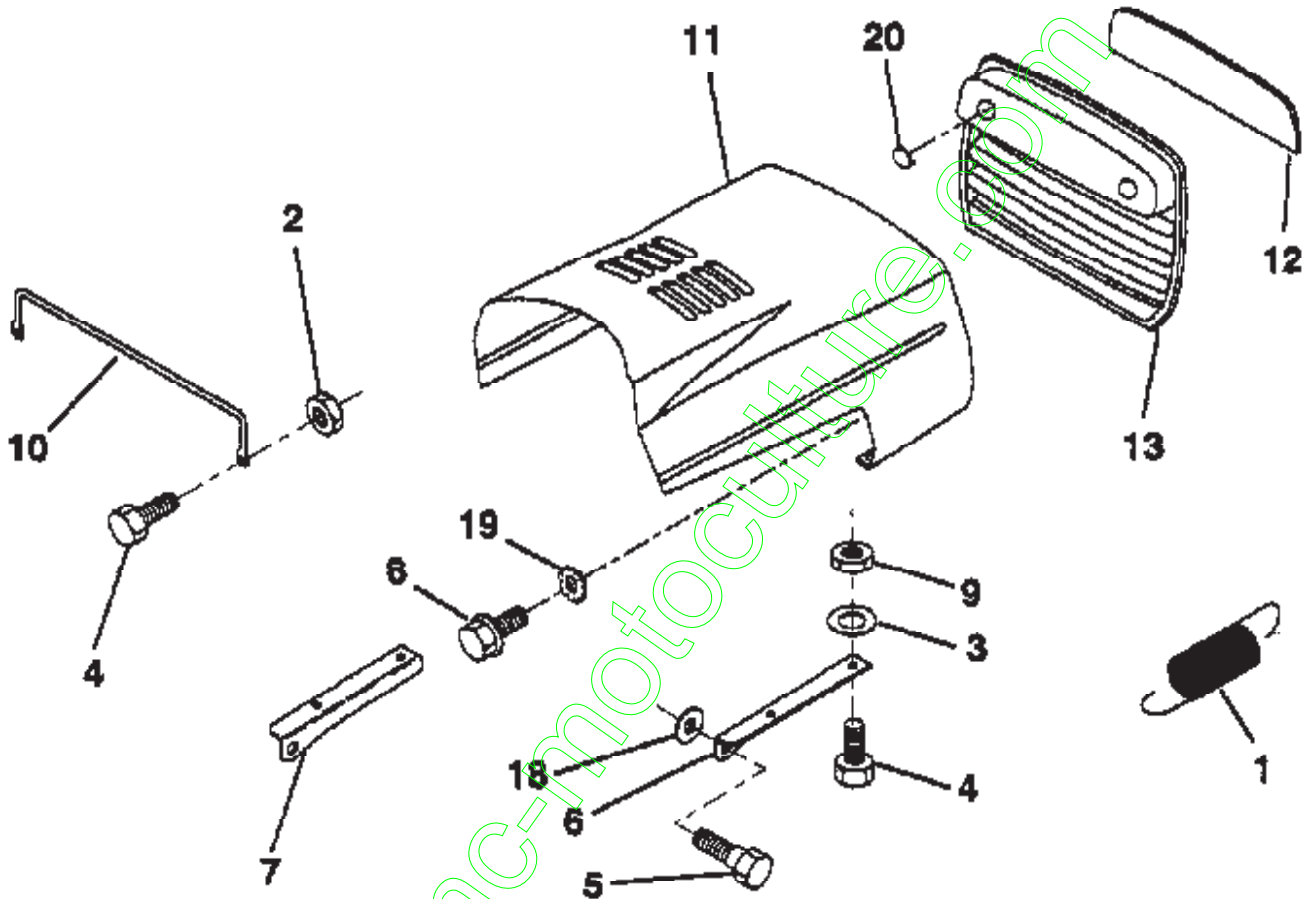

NOTE: All component dimensions given in U.S. inches.
1 inch = 25.4 mm.

www.emc-motoculture.com

Ref #	Part Number	Qty	Description
1	124657X		EXT SPRING
2	73640400		NUT HXKEP 1/4X20
3	19091416		WASHER
4	74780412		SUB= 74780414
5	139888		BOLT.SHLD.5/16-18
6	122549X		BRKT HOOD RH
7	122548X		BRKT HOOD LH
8	17521312		SCREW SLTD HXHD
9	73800400		NUT
10	123693X		"BRACE,HOOD"
11	132918X505		HOOD
12	122035X		LENS
13	127029X		GRILL
18	19111116		WASHER
19	11030400		LOCKWASHER GT
20	131319		SUB= 532131319

www.emc-motoculture.com

TRACTOR -- MODEL NUMBER CP10910A

MOWER DECK

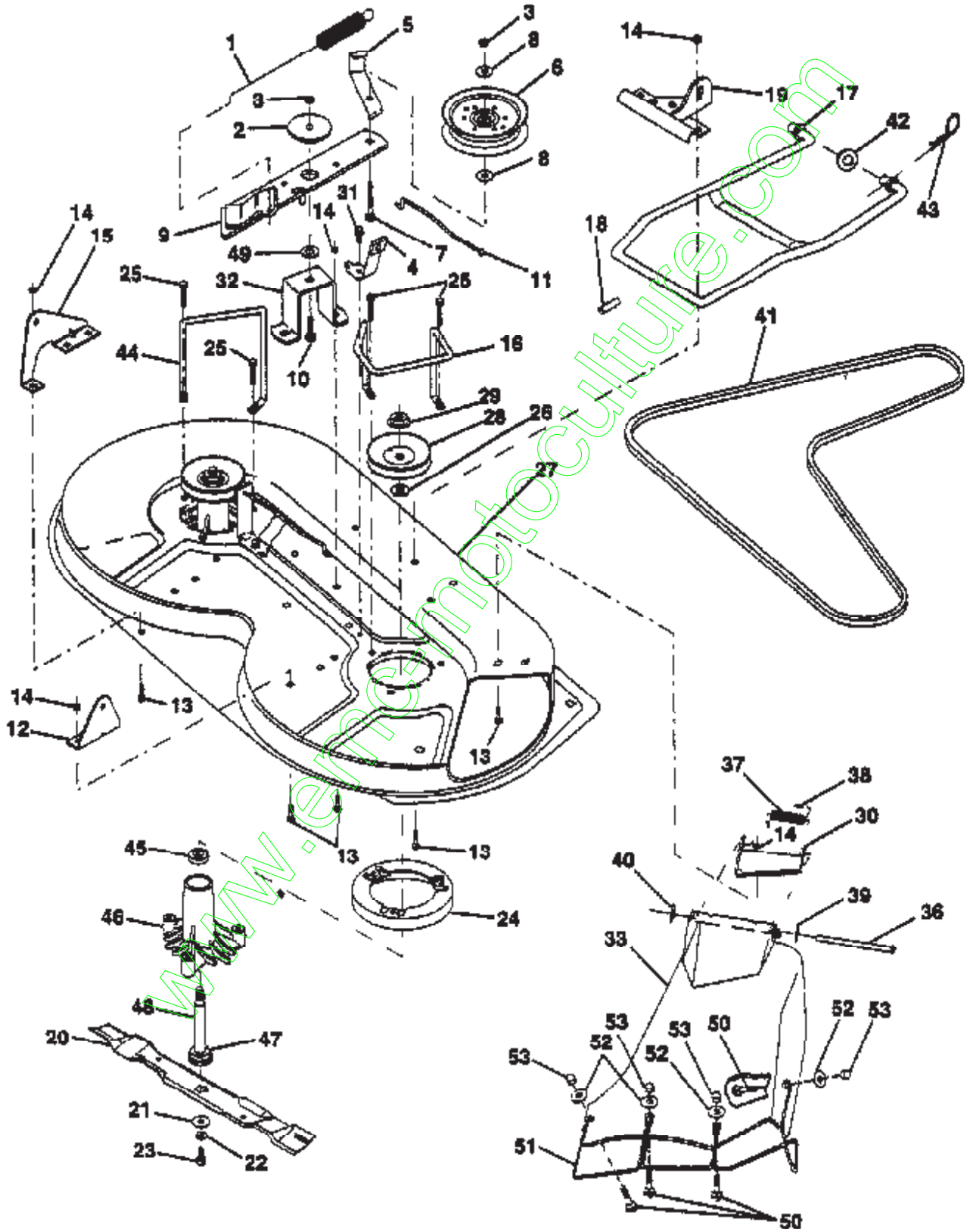

Ref #	Part Number	Qty	Description
1	140064		SPRING CLUTCH MWR
2	122052X		SPACER RETAINER
3	73680600		SUB= 73690600
4	130840		BRAKE ASM
5	131251		IDLER BELT GUIDE
6	121316X		PULLEY IDLER
7	72110616		BOLT
8	19131410		WASHER
9	127744		SUB= 140092
10	72140610		BOLT.3/8-14X1.25
11	130841		BRAKE ROD
12	127356		"BRKT,LIFT REAR"
13	72140506		BOLT
14	73680500		SUB= 73690500
15	127357		"BRKT,LIFT REAR LH"
16	140093		SUB= 153298
17	128508		MOWER LINK STAB
18	128511		"PIN,GROOVE"
19	127380		"BRKT,LINK STABLI"
20	138496		"BLADE 36"" HIPERF"
21	140296		WASHER.HARD.BLADE
22	10030600		SUB= 10040600
23	850857		BLADE BOLT
24	140329		STRIPPER RND MWR
25	138776		SUB= 157722
26	129963		WASHER
27	129983		SUB= 156600
28	129207		SUB= 153531
29	137266		SUB= 139729
30	136631		SUB= 532136631
31	17490508		SCREW LT
32	122051X		"SUPT,IDLER ARM"
33	139083		SHIELD.DEFL.36TUV
36	121980X		HINGE ROD
37	123713X		SPRING TORSION
38	105304X		CAP-SLEEVE LT
39	19111016		WASHER
40	110452X		NUT PUSH M
41	131264		V-BELT.PRIM.78.5.
42	19171616		WASHER
43	3146R		RETAINER.SPRING
44	140608		KEEPER BELT LH
45	110485X		BEARING
46	128774		HSG ASM MANDREL
47	129895		BEARING.BALL
48	137645		SUB= 137646
49	133943		HARDENED WASHER
50	M720305016		BOLT M5X0.8X16
51	136383		GUARD.DFTR.MWR.36
52	19070718		NLA
53	M730705000		"NUT, M5X0.8"
	130794		MANDREL ASM
	144973		DECK.36.LR

TRACTOR - - MODEL NUMBER CP10910A

MOWER LIFT LEVER

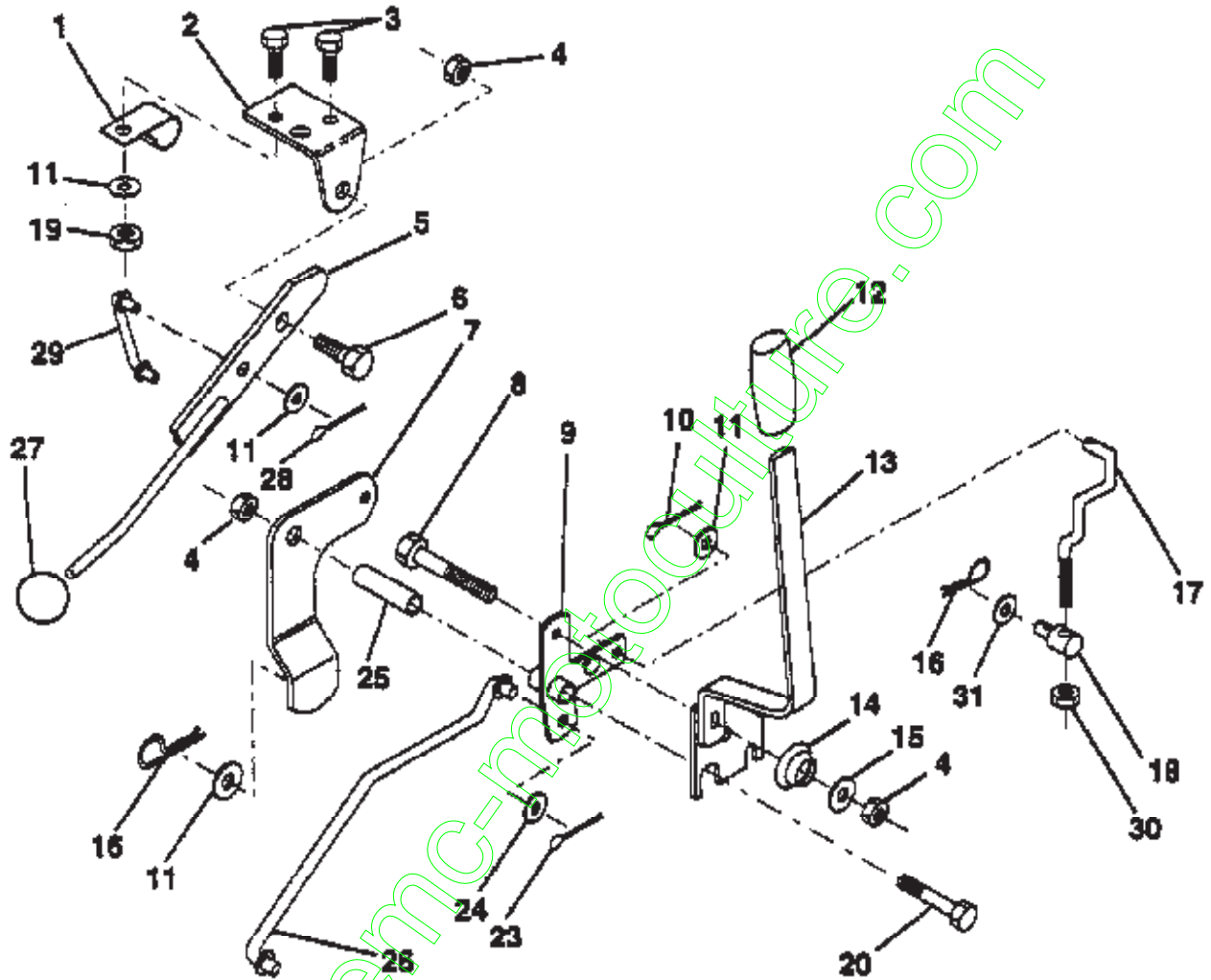

NOTE: All component dimensions given in U.S. inches.
1 inch = 25.4 mm.

Ref #	Part Number	Qty	Description
1	126470X		"CLIP,INSULATOR"
2	122018X		BRKT CLUTCH
3	71110408		BOLT HXHD FIN
4	73680600		SUB= 73690600
5	145187		LEVER.ASM.CLUTCH
6	106451X		"BOLT, SHOULDER LT"
7	135371		MWR CLUTCH ARM AS
8	74760636		BOLT
9	121930X		"BELLCRANK,LIFT"
10	76020412		COTTER PIN
11	19131316		WASHER
12	131861		SUB= 532131861
13	139352		HANDLE.ASM.LIFT
14	123496X		SPRING COMPRESSIO
15	19131212		WASHER T
16	4921H		SPRING.RETAINER
17	127359		"LINK,LIFT FRT"
18	142028		TRUNION ADJ
19	73680400		SUB= 73690400
20	74760644		BOLT
23	76020416		PIN COTTER 1/8
24	19171616		WASHER
25	121933X		TUBE SPACER
26	141470		ROD LIFT MOWER
27	106932X		KNOB T(3/8 HOLE)
28	73020312		PIN, COTTER
29	131655		CLUTCH LINK
30	73350600		NUT
31	19132012		WASHER

www.emc-motors.com

TRACTOR - - MODEL NUMBER CP10910A

SEAT

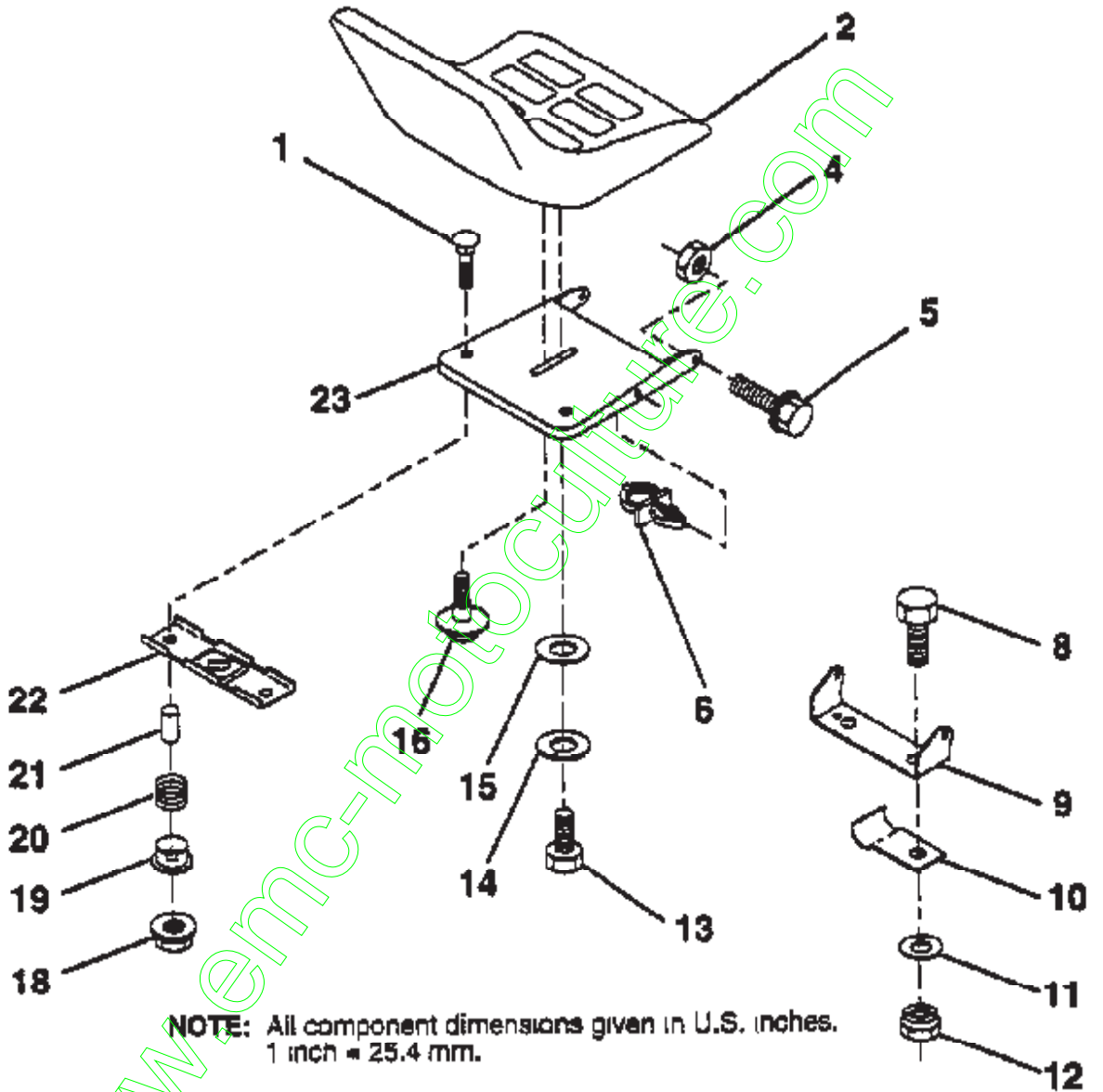

Ref #	Part Number	Qty	Description
1	72050411		SUB= 872050411
2	134647		SUB= 140119
4	73800500		NUT
5	139888		BOLT.SHLD.5/16-18
6	145006		CLIP.PUSH-IN.HING
8	74760616		BOLT
9	140551		BRACKET PVT SEAT
10	126471X		"CLIP,INSULATOR"
11	19133210		WASHER
12	73800600		NUT
13	74780814		BOLT
14	10040800		LOCKWASHER
15	19171912		WASHER
16	127018X		"BOLT,SHOULDER"
18	123976X		SUB= 73900400
19	121248X		BUSHING
20	121250X		SPRING
21	134300		SPLIT SPACER
22	121246X		BRKT SWITCH
23	140552		SUB= 155925

www.emc-motoculture.com

TRACTOR -- MODEL NUMBER CP10910A
SECTOR GEAR / AXLE SUPPORT

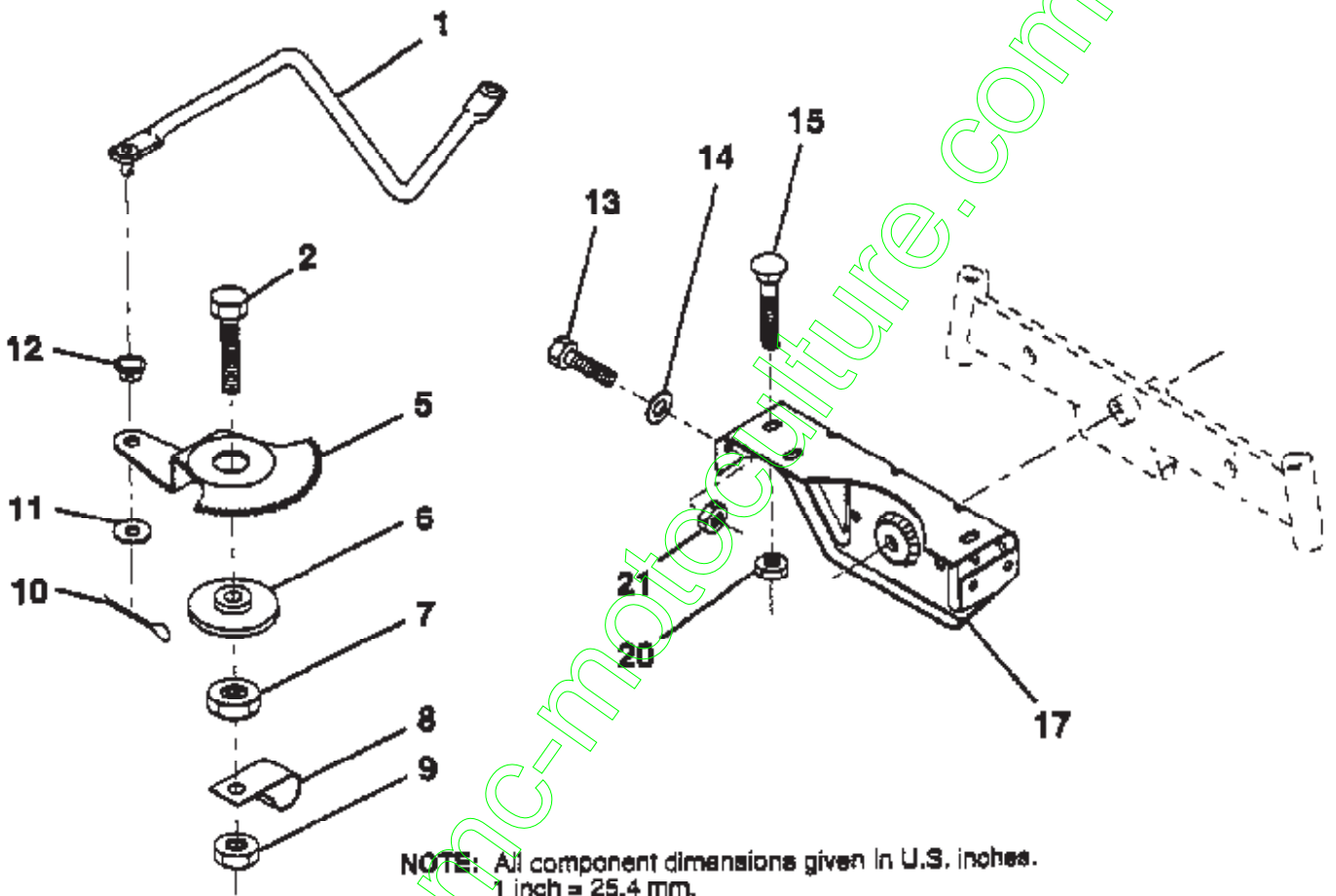

Ref #	Part Number	Qty	Description
1	132566		DRAG LINK
2	74780828		"BOLT,HEX"
5	121926X		GEAR SECTOR
6	121927X		BUSHING
7	73030800		NUT
8	126472X		CLIP INSULATOR
9	73680800		NUT LTV
10	76020412		COTTER PIN
11	19131316		WASHER
12	126847X		BUSHING.DRAGLINK
13	74760512		BOLT
14	19111416		WASHER
15	72110606		BOLT
17	137096		SUPT AXLE FRONT
20	73680600		SUB= 73690600
21	73680500		SUB= 73690500

www.emc-motoculture.com

TRACTOR -- MODEL NUMBER CP10910A

STEERING WHEEL

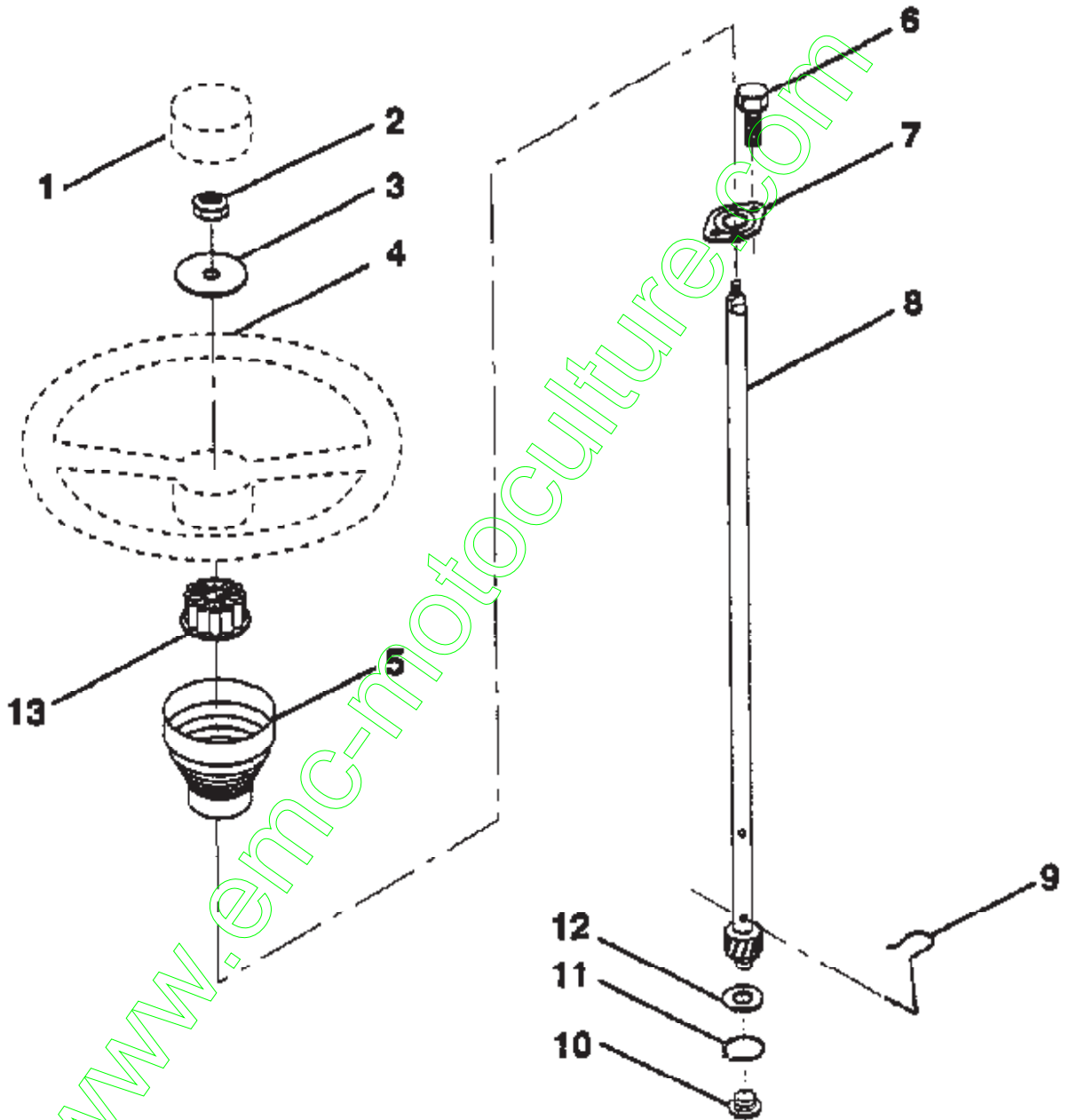

NOTE: All component dimensions given in U.S. inches.
1 inch = 25.4 mm.

Ref #	Part Number	Qty	Description
1	133742		ST WHL INSERT CAP
2	7810H		GRIPCO NUT
3	19133808		WASHER T
4	133741		SUB= 150547
5	121897X		SLEEVE STEERING
6	17431008		SUB= 98000165
7	102803X		SUB= 918102803X
8	123651X		SUB= 148966
9	124210X		STEERING CLIP
10	123438X		BUSHING STEER LWR
11	1200045		RING
12	19211616		WASHER LT
13	104820X		ADAPTER-WHEEL LT

www.emc-motoculture.com

TRACTOR -- MODEL NUMBER CP10910A DANA TRANSAXLE - MODEL NUMBER 4360-77

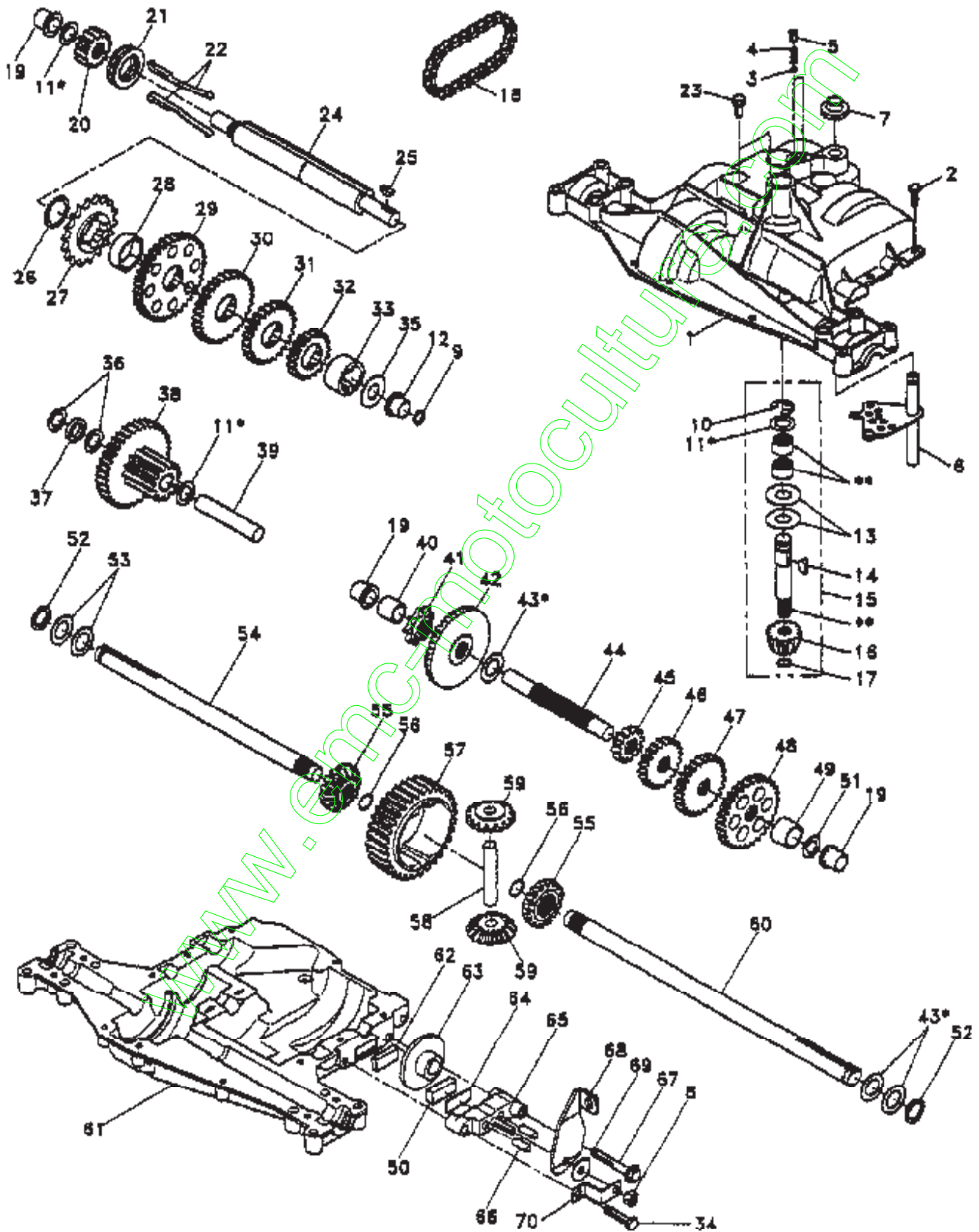

Ref #	Part Number	Qty	Description
1	142671		HOUSING UPPER TRN
2	2274J		SUB= 74760412
3	134400		SUB= 68003
4	105904X		"SPRING, DETENT LT"
5	105905X		"SCREW, SET LT"
6	138235		KIT SHIFTER ASM
7	134399		SHIFTER BOOT
8	73810500		NUT.LOCK.5/16-24
9	143045		SEAL OIL DANA5416
10	142672		SUB= 2225J
11	134793		ASM KIT SHIM 4689
12	143051		SUB= 148268
13	120415X		WASHER T
14	142674		KEY WOODRUFF-DANA
15	138234		AS KIT INPUT SHFT
16	110078X		PINION 14T T
17	105909X		"RING,RETAINING LT"
18	105910X		"CHAIN,24 PTCH LT"
19	105911X		BEARING.FLNG.5510
20	142675		GEAR SPUR 14 TTH
21	138246		COLLAR CLUTCH
22	138236		ASM KIT CLTCH KEY
23	134791		SCREW TAP W/SEAL
24	142676		SHAFT INTERM DANA
25	2244J		WOODRUFF KEY
26	105916X		"RING,RETAINING LT"
27	120470X		SPROCKET 18T T
28	110070X		SPACER YT
29	142677		GEAR SPUR 37 TTH
30	120405X		SUB= 124644X
31	108980X		GEAR 25T LT
32	134796		SPUR GEAR 19T
33	138239		SPACER
34	106596X		"SCREW, TAPPING LT"
35	105925X		"WASHER, PLAIN LT"
36	2232J		WASHER 025
37	108978X		SPACER
38	110079X		ASSM GEAR COMB
39	124639X		SHAFT IDLER
40	120472X		SPACER T
41	105928X		SPROCKET 9T LT
42	110084X		SUB= 167148
43	134394		ASM KIT SHIM
44	120473X		SHAFT T
45	142678		GEAR SPUR 12 TTH
46	120407X		SUB= 124641X
47	106589X		"GEAR, SPUR 25T LT"
48	105937X		"GEAR, SPUR 31T LT"
49	120523X		SPACER T
50	120951X		PUCK T
51	2226J		WASHER 060
52	134401		NEOPRENE WASHER
53	2264J		WASHER 031
54	120474X		SUB= 154658
55	110081X		GEAR 15T T
56	105941X		"RING,RETAINING LT"
57	110071X		SUB= 120478X
58	120952X		SHAFT T

Ref #	Part Number	Qty	Description
59	110082X		GEAR 1ST T
60	120475X		SUB= 154659
61	142680		HOUSING LOWER TNS
62	120961X		PUCK T
63	7294J		BRAKE DISC. T
64	108989X		SPACER LT
65	120953X		SUB= 918120953X
66	120954X		PIN T
67	134799		TAP SCREW
68	138244		SUB= 108992X
69	108996X		WASHER LT
70	120956X		NLA
71	120416X		SUB= 126976X

www.emc-motoculture.com

TRACTOR - - MODEL NUMBER CP10910A

TRANSAXLE

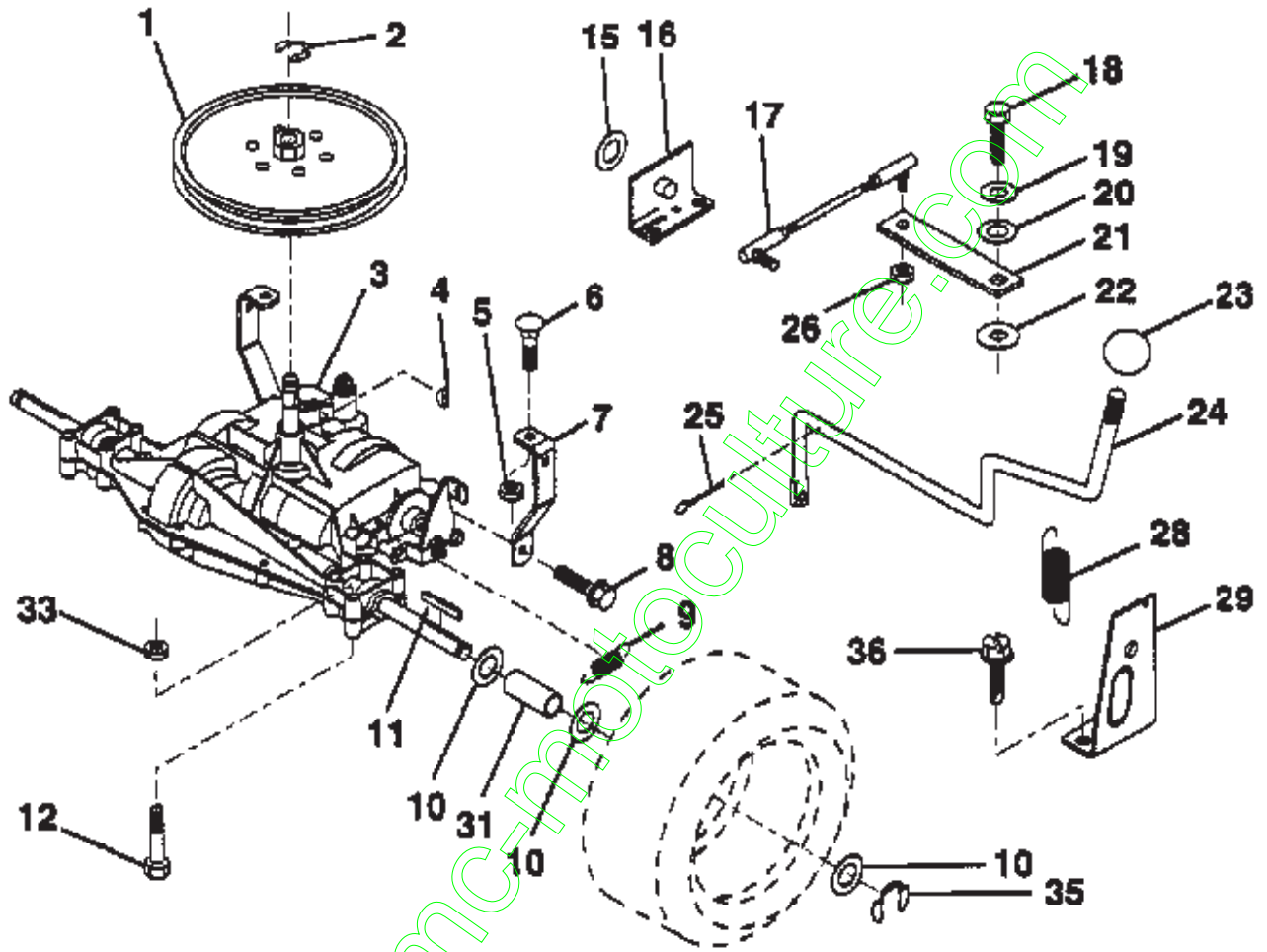

NOTE: All component dimensions given in U.S. inches.
1 inch = 25.4 mm.

www.emc-motoculture.com

Ref #	Part Number	Qty	Description
1	123385X		PULLEY
2	12000028		SUB= 2267J
3	142594		SUB= 918142594
4	2228M		SUB= 2228M1
5	73680500		SUB= 73690500
6	72140506		BOLT
7	123378X		"STRAP,TORQUE"
8	17490512		SCREW
9	146682		SPRING,BRAKE.RETU
10	121749X		WASHER
11	123583X		SQUARE KEY
12	74760644		BOLT
15	19171616		WASHER
16	124600X		"SUPT,HDLE SHT LH"
17	123632X		"LINK,SHIFT"
18	74550412		BOLT.1/4-28.W/PAT
19	10040400		LOCKWASHER
20	19091210		WASHER LT
21	123484X		ARM,SHIFT
22	105701X		WASH-SHFT,PLT LT
23	106933X		KNOB T (1/2-HOLE)
24	128215		"ROD,SHIFT"
25	76020416		PIN,COTTER 1/8
26	73810500		NUT,LOCK.5/16-24
28	128085		"SPRING,EXT"
29	128084		"SUPT,HDLE RH"
31	109502X		SPACER LT
33	73680600		SUB= 73690600
35	12000001		E-RING LT
36	17720408		SCREW

www.emc-motorsupply.com

TIRES & WHEELS

TRACTOR -- MODEL NUMBER CP10910A

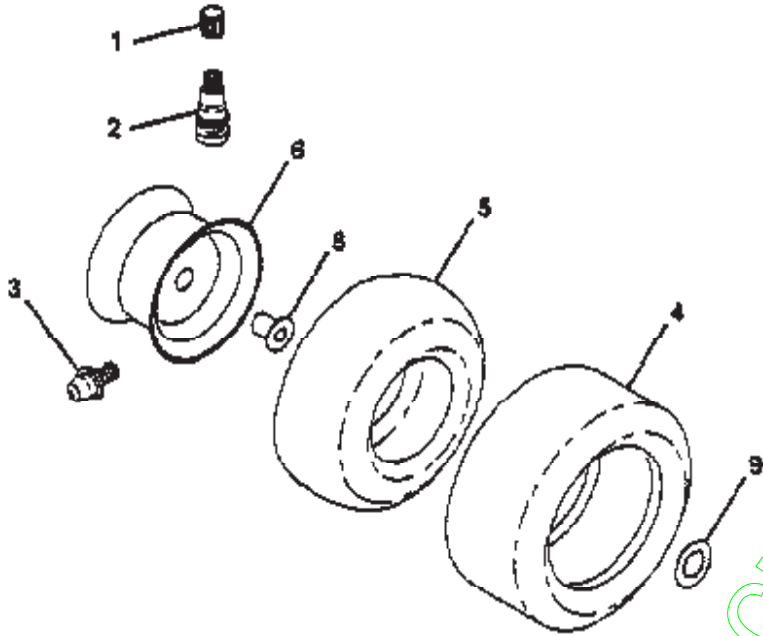

www.emc-motoculture.com

Ref #	Part Number	Qty	Description
1	59192		VALVE CAP
2	65139		VALVE STEM LT
3	278H		FITTING LT
4	124142X		SUB= 123410X
	124143X		SUB= 122075X
5	59904		TUBE.5.3/4.5/6
	8134H		TUBE.16X6.5/7.5-8
6	137237X427		"RIM FRONT 6""
	140325X427		"RIM ASM REAR 8""
8	9040H		"FLANGE, BEARING"
9	121748X		WASHER
	144334		SEALANT.TIRE 10 OZ TUBE

www.emc-motoculture.com