



PARTS CATALOGUE

ECHO CHAIN SAW CS-280EVL

- Please refer this parts catalogue for following types of CS-280EVL
 - Front hand guard type chain saw
 - Chain brake type chain saw
 - Sprocket pitch: 1/4 in
3/8 in
 - Muffler: Standard type muffler
Spark arrester & Noise level regulation type



7500715330

Front type

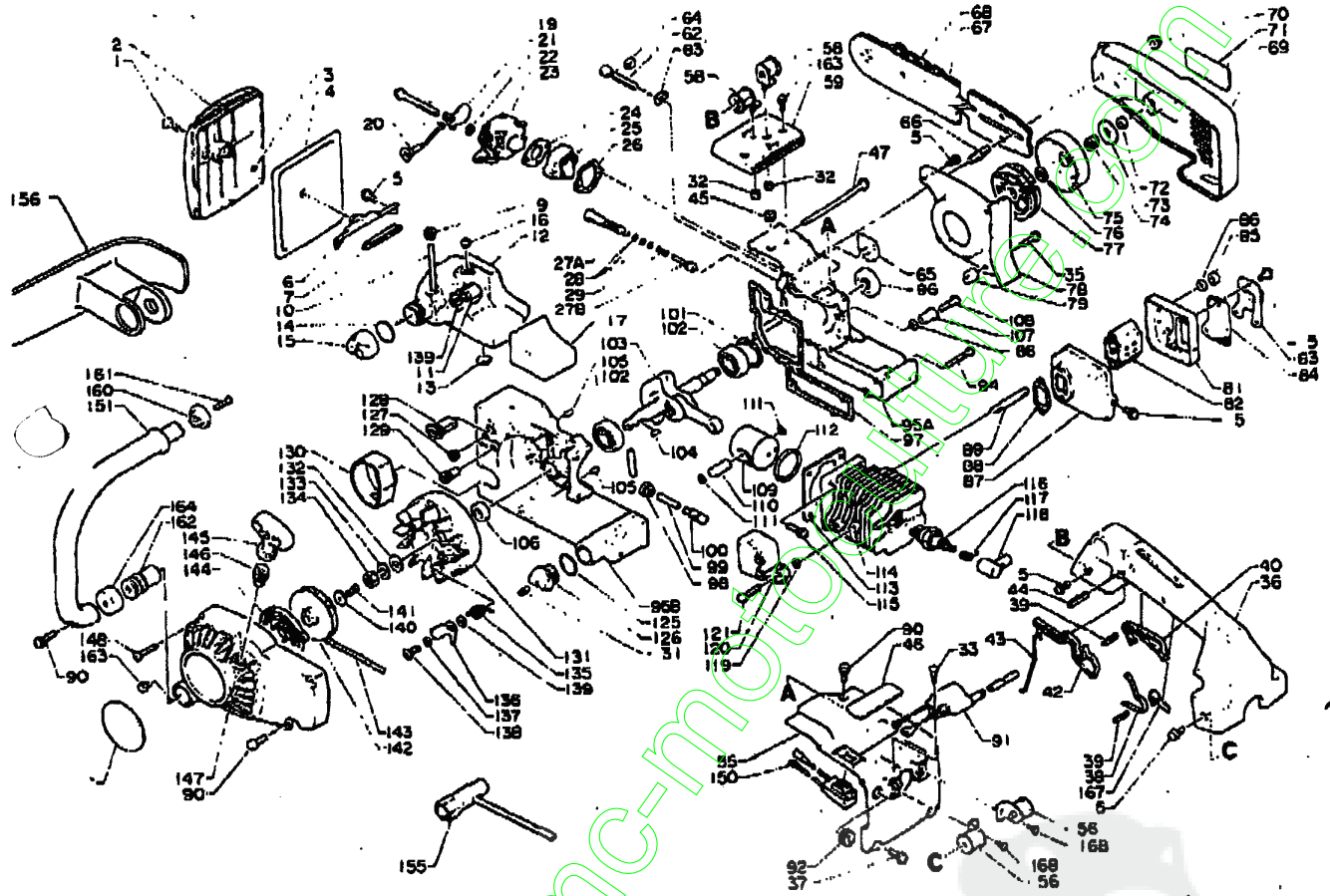

Sales

Sales

Pitch 3/8" (91S)		Saw chain and guide bar		Pitch 1/4"	
1- 67	-	1	Guide bar	1- 67	430 411-1393 0
68	-	1	Saw chain	68	431 611-1003 0
75	175 005-1899 0	1	Clutch case 3/8	75	175 007-1393 1
	15330				1
					1
					1

Key No.	Part No.	Q'ty	Description	Key No.	Part No.	Q'ty	Description
1- 4	130 302-1503 1	1	Cover ass'y, air cleaner	1- 15	131 017-1393 1	1	Cap, fuel tank
1	130 406-1393 1	1	Thumb bolt	16	131 314-0033 0	1	Check valve
2	130 313-1503 1	1	Cover, air cleaner	17	131 924-1393 0	1	Cushion
3	900 700-0000 3	1	Circclip 3	19	900 242-0505 0	2	Screw 5 x 60
4	130 310-1393 0	1	Air filter	20	178 510-1393 0	1	Choke rod
5	800 242-0401 0	8	Screw 4 x 10	21	178 515-1393 0	1	Choke shutter
6	130 405-1393 1	1	Bracket, air filter	22	178 516-0393 0	1	Spacer
7	131 920-1393 0	1	Cushion	23	125 200-1393 2	1	Carburetor ass'y
9	132 115-0148 0	1	Grommet	24	130 016-0643 0	1	Gasket
10	132 010-1393 2	1	Fuel pipe	25	130 000-1393 1	1	Insulator
11	131 205-0083 0	1	Fuel strainer	26	130 010-1393 0	1	Gasket
12	131 010-1393 0	1	Fuel tank	27	437 000-1393 0	1	Auto. oiler ass'y
13	100 223-1393 1	1	Cushion	28	437 020-0283 0	3	O-ring
14	131 004-1393 1	1	Cap ass'y, fuel tank	29	437 019-0283 0	1	Coil spring
	131 016-1393 0	1	Gasket, fuel tank	32	900 515-0000 5	2	Flange nut 5

437 000 11230
7500715330

CSB 30EVL

62.74

Key No.	Part No.	Q'ty	Description	Key No.	Part No.	Q'ty	Description
1- 33	900 248-0401 6	2	Tapping screw 4 x 16	1- 107	433 011-1393 0	1	Chain catcher 433-000-139-
35	900 242-0402 0	1	Screw 4 x 20	88	900 602-0000 5	1	Washer 5
36	351 100-1493 0	1	Top handle	108	900 220-0502 0	1	Screw 5 x 20 900-242-050
37	900 242-0401 8	2	Screw 4 x 18	109	100 000-1393 1	1	Piston
38	178 091-1493 0	1	Spring	110	100 Q13-1393 0	1	Piston pin
39	900 340-4002 0	2	Spring pin 4 x 20	111	100 015-0463 0	2	Circlip, piston pin
40	178 090-1493 0	1	Throttle control lockout	112	100 011-0573 1	1	Piston ring
42	178 010-1493 0	1	Throttle trigger	113	101 010-1393 0	1	Gasket, cylinder base
43	178 011-1493 0	1	Throttle rod	114	101 011-1393 0	1	Cylinder
44	900 340-4002 6	1	Spring pin 5 x 25	115	900 242-0502 0	4	Screw 5 x 20
45	178 210-0023 0	1	Grommet	116	159 010-1393 0	1	Spark plug CJBY
48	890 151-1493 0	1	Decal	117	159 011-0051 0	1	Coil spring, plug cap
47	100 244-1393 0	2	Screw	118	159 012-0182 0	1	Cap, spark plug
55	101 514-1493 0	1	Cylinder cover	119	152 117-0553 0	2	Spacer
56	351 107-1493 0	2	Cushion	120	159 601-1503 0	1	C.D. Ignition module SK4
58	351 105-1493 0	2	Cushion	121	900 242-0502 2	2	Screw 5 x 22
59	130 348-1493 0	1	Cover	***	436 001-1393 2	1	Cap ass'y, oil tank
62	433 016-1393 0	1	Adjusting screw	31	438 114-1393 0	1	Check valve(s)
63	433 014-1123 0	1	Tensioner	125	900 720-0001 6	1	O-ring 16
64	433 028-1103 0	1	Clip	126	436 013-1393 2	1	Cap, oil tank 4-36 ass'i 1393
66	100 614-1393 0	1	Plug	127	178 810-0333 0	1	Grommet
66	433 011-1393 0	2	Stud	128	129 010-1393 0	1	Grommet
69	433 010-1493 0	1	Cover guide bar	129	129 015-1393 0	1	Grommet
70	433 019-0393 2	2	Flange nut-6	130	131 038-1393 0	1	Seal
71	890 137-1393 0	1	Decal, ECHO	131	156 800-1393 0	1	Flywheel
72	100 138-0393 0	1	Nut	132	900 600-0000 8	1	Washer 8
73	175 015-1393 1	1	Washer	133	900 805-0000 8	1	Spring washer 8
74	175 012-0393 0	1	Needle bearing	134	900 502-0000 8	1	Nut 8
76	175 014-1123 1	1	Washer	135	177 234-1393 0	2	Return spring, ratchet
77	175 000-1393 0	1	Clutch ass'y	138	177 218-1393 0	2	Ratchet
78	175 305-1393 0	1	Seal plate	137	177 247-0463 0	2	Spacer
79	175 311-1393 0	1	Spacer	138	177 217-1393 0	2	Screw
81	145 881-1393 0	1	Lid	139	900 603-0000 5	3	Washer 5
82	145 859-1393 0	1	Adapter	****	177 200-1393 1	1	Recoil starter ass'y
83	145 876-1393 0	1	Muffler lid	140	177 214-0463 0	1	Washer
84	145 882-1393 1	1	Screen (option)	141	900 241-0401 0	1	Screw 4 x 10
85	433 020-0083 0	2	Lock nut 5	142	177 215-0653 0	1	Recoil drum
86	900 602-0000 5	2	Washer 5	143	177 228-0853 0	1	Rope
87	145 858-1393 1	1	Muffler	144	177 220-0853 0	1	Rewind spring
88	145 510-1393 0	1	Gasket, muffler	145	177 228-1113 0	1	Starter handle
Spark arrester & Noise level regulation (83 and 84)				146	177 227-0533 0	1	Rope guide
83	145 867-1393 0	1	Muffler lid	147	101 507-1393 1	1	Fan cover
84	145 882-1393 1	1	Screen	148	900 242-0402 5	1	Screw 4 x 25
89	101 014-0713 1	2	Stud	149	890 310-1493 0	1	Decal
90	900 242-0401 6	5	Screw 4 x 16	150	163 400-1493 0	1	Switch < R54
91	156 826-1493 0	1	Ignition coil	151	351 806-1493 0	1	Front handle
92	150 814-0291 0	1	Grommet	155	895 410-0393 0	1	Wrench w/s, driver
94	900 242-0403 0	7	Screw 4 x 30	156	351 828-1493 0	1	Guard, front
95	100 200-1393 3	1	Crankcase set	160	351 846-1493 0	1	Holder, handle
105	100 215-0393 0	2	Knock pin	161	900 214-0502 5	1	Screw 5 x 25
96	100 213-0393 0	1	Oil seal	162	351 621-1503 0	1	Cushion
97	100 242-1393 1	1	Gasket, crankcase	163	900 242-0401 2	2	Screw 4 x 12
98	132 116-1113 0	1	Grommet	164	351 638-1493 0	1	Stopper
99	437 210-1393 0	1	Oil pipe	167	178 092-1493 0	1	Spacer
100	436 205-0283 2	1	Oil strainer	168	900 248-0401 0	3	Tapping screw 4 x 10
101	900 702-0003 2	1	Circlip 32	Remarks: * : Consists of 1 thru 3. ** : Consists of 14 and 15. *** : Consists of 31, 125 and 126. **** : Consists of 140 thru 147. 27: Includes 28 and 29. 95: Includes 105. 107: Includes 86 and 108.			
102	900 810-3620 1	2	Ball bearing 6201				
103	100 100-1393 1	1	Crankshaft ass'y				
104	100 131-0852 0	1	Woodruff key				
108	100 212-1123 0	1	Oil seal				

naid

The following
changed on

s shown in front page are
crsf. type.

Key No.	Delete	Insert		Description
		Q'ty	Q'ty	
1- 5	-	8	-	7 Screw 4 x 10
35	900 242-0402 0	1	-	Screw 4 x 20
65	100 814-1393 0	1	-	Plug
78	175 305-1393 0	1	-	Seal plate
79	175 311-1393 0	1	-	Spacer
156	351 826-1493 0	1	-	Guard, front
160	351 646-1493 0	1	-	Holder, guard
161	900 214-0502 5	1	900 214-0501 8	Screw 5 x 18

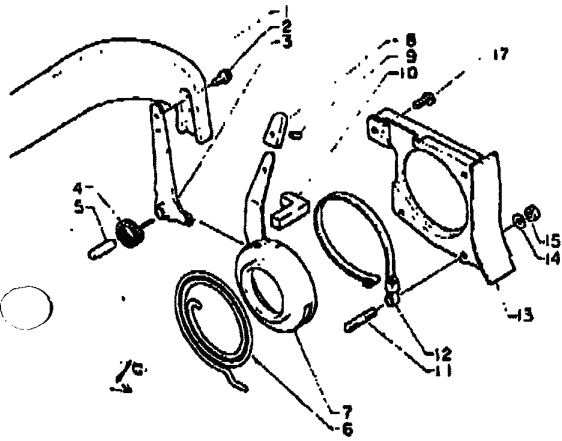

Key No.	Part No.	Q'ty	Description
2- 1	433 111-1393 0	1	Brake handle
2	900 242-0401 0	2	Screw 4 x 10
3	433 112-1393 0	1	Arm
4	433 114-1393 0	1	Spring
5	900 334-8002 0	1	Shaft
6	433 122-1393 0	1	Brake spring
7	433 109-1393 1	1	Band case
8	433 152-1393 0	1	Grip
9	900 340-3000 8	1	Spring pin 3 x 8
10	433 313-1393 0	1	Dust seal
11	433 130-1393 0	1	Stud
12	433 123-1393 2	1	Brake band
13	433 305-1393 1	1	Seal plate
14	177 214-0393 0	1	Washer
15	900 500-0000 4	1	Nut 4
17	900 220-0401 0	1	Screw 4 x 10

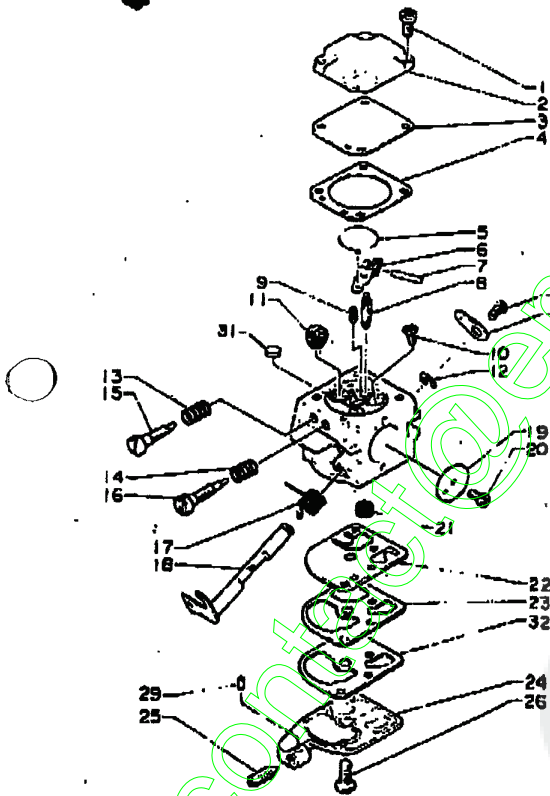

Key No.	Part No.	Q'ty	Description
3- 1	125 200-1393 2	1	Carburetor ass'y C18-K18
2	-125 344-1393 0	4	Screw
3	-125 342-1393 0	1	Cover, diaphragm
4	-125 341-1393 0	1	Diaphragm
	-125 340-1393 0	1	Gasket, diaphragm
5	-125 375-1393 0	1	Disc
6	-125 323-1393 0	1	Valve arm
7	-125 338-1393 0	1	Arm pin
8	-125 337-1393 0	1	Needle valve
9	-125 322-1393 0	1	Coil spring
10	-125 339-1393 0	1	Screw
11	-125 376-1393 0	1	Orifice, main fuel
12	-125 327-1393 0	1	Clip
13, 14	-125 319-1393 0	2	Coil spring
15	-125 320-1393 0	1	Needle, high speed
16	-125 318-1393 0	1	Needle, idle
17	-125 313-1393 0	1	Return spring, throttle
18	-125 317-1393 0	1	Throttle shaft
19	-125 316-1393 0	1	Throttle shaft
19	-125 316-1393 0	1	Throttle shutter
20	-125 314-1393 0	1	Screw
21	-125 326-1393 0	1	Screen
22	-125 312-1393 1	1	Diaphragm, fuel pump
23	-125 325-1393 1	1	Gasket, fuel pump
24	-125 324-1393 1	1	Pump cover
25	-125 334-1393 0	1	Screw, idle adjustment
26	-125 310-1393 0	1	Screw
27	-125 348-1393 0	1	Screw
28	-125 350-1393 1	1	Throttle lever
29	-125 378-1393 0	1	Friction piece
31	-125 345-1393 0	1	Welsh plug
32	-125 311-1513 0	1	Diaphragm surge

Remark:
Consists of 1 thru 32.



KIORITZ CORPORATION

5-1 SHIMORENJAKU, 7-CHOME, MITAKA, TOKYO 181
CABLE ADDRESS: KIORITZ MITAKA
TELEX ADDRESS: KIORITZ A J28592