

EL63 EL63 M

CATALOGO DELLE PARTI DI RICAMBIO
SPARE PARTS CATALOGUE
CATALOGUE DES PIECES DE RECHANGE
ERSATZTEILKATALOG

2005



EL63
EL63 M

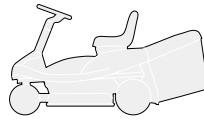

CATALOGO PARTI DI RICAMBIO
SPARE PARTS CATALOGUE
CATALOGUE DE PIECES
ERSATZTEILKATALOG

2005
000.0
1 / 6

COME USARE IL CATALOGO

HOW TO USE THE CATALOGUE

COMMENT UTILISER LE CATALOGUE

WIE IST DER KATALOG ZU BENUTZEN

1. Generalità

Questo catalogo contiene tutte le informazioni necessarie per ordinare correttamente i pezzi di ricambio.

1. General information

This catalogue contains all the information necessary for correctly ordering spare parts.

1. Généralités

Ce catalogue contient toutes les indications nécessaires pour commander correctement les pièces détachées.

1. Allgemeines

Dieser Katalog enthält alle Informationen, die für die korrekte Bestellung von Ersatzteilen erforderlich sind.

2. Struttura del catalogo

In ogni pagina del catalogo sono riportate le seguenti indicazioni:

2. Structure of the catalogue

Each page of the catalogue has these indications:

2. Structure du catalogue

Les indications suivantes sont reportées sur chaque page du catalogue:

2. Aufbau des Katalogs

Auf jeder Seite des Katalogs sind die folgenden Angaben wiedergeben:

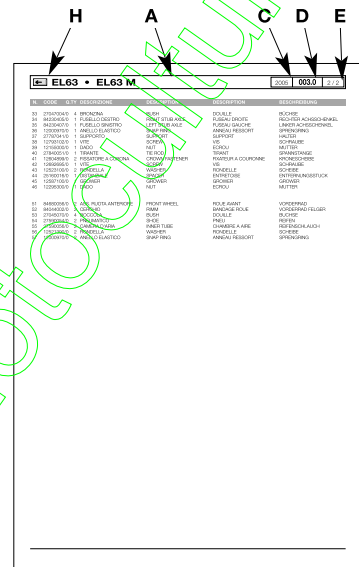
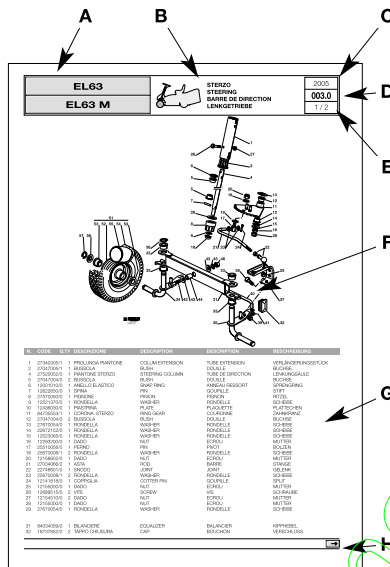

A. Macchina o serie di macchine per le quali la pagina è valida.

A. Machine or machine series to which the page applies.

A. La machine ou la série de machines auxquelles se réfère la page.

A. Maschine oder Serie der Maschine, für welche die Seite gültig ist.

B. Indicazione del gruppo con la raffigurazione in miniatura della sua collocazione sulla macchina.

B. Indication of the unit with a miniature drawing showing its position on the machine.

B. L'indication du groupe avec la représentation en miniature de sa position sur la machine.

B. Bezeichnung der Gruppe mit einer Miniaturdarstellung ihrer Anbringung auf der Maschine.

C. Anno di produzione della macchina a cui si riferisce.

C. Year of production of the machine concerned.

C. L'année de fabrication de la machine concernée.

C. Herstellungsjahr der betreffenden Maschine.

D. Numerazione progressiva della tavola, secondo il seguente criterio:

- le prime tre cifre indicano il numero progressivo;
- le eventuali lettere che seguono indicano le diverse versioni alternative di quel gruppo;
- la cifra dopo il punto indica un eventuale aggiornamento nel corso della annualità indicata al punto 3.

D. Progressive numbering of the table, arranged as follows:

- the first three numbers are the progressive number;
- any letters that follow will indicate the various alternative versions of that unit;
- the number after the dot is for any updates during the year given at point 3.

D. La numérotation progressive du tableau, selon le critère suivant:

- les trois premiers chiffres indiquent le numéro progressif;
- les éventuelles lettres qui suivent indiquent les différentes versions alternatives de ce groupe;
- le chiffre après le point indique l'éventuelle mise à jour effectuée au cours de l'année indiquée au point 3.

D. Progressive Numerierung der Tafel nach folgendem Kriterium:

- die ersten drei Ziffern bezeichnen die progressive Nummer;
- die eventuellen Buchstaben, die folgen, bezeichnen die verschiedenen alternativen Versionen dieser Gruppe;
- die Ziffer nach dem Punkt bezeichnet einen eventuellen neueren Stand im Laufe des Jahrgangs, der in Punkt 3 angegeben ist.

Esempio:

011a.0 =

011 Parti elettriche
a Avviamento manuale
.0 Prima stesura

Example:

011a.0 =

011 Electrical parts
a Manual start
.0 First copy

Exemple

011a.0 =

011 Parties électriques
a Démarrage manuel
.0 Première rédaction

Beispiel:

011a.0 =

011 Elektrischeteil
a Anlassen von Hand
.0 Erste Ausgabe





E. Numero della pagina e numero totale delle pagine necessarie per la descrizione del gruppo.

F. Vista esplosa del gruppo.

G. Descrizione completa dei singoli particolari, con codice e quantità di pezzi.

H. Indicazione della presenza di altre pagine di seguito.

Nelle pagine di seguito, sono riportate nuovamente le indicazioni relative ai punti A - C - D - E - G e H.

E. Page number and total number of pages necessary for the description of the unit.

F. Exploded view of the unit.

G. Full description of each part, with code number and number of pieces.

H. Indication of additional pages.

The additional pages repeat the indications as at points A - C - D - E - G and H.

E. Numéro de la page et nombre total des pages nécessaires pour la description du groupe.

F. Vue éclatée du groupe.

G. Description complète de chaque élément, avec code et quantité des pièces.

H. Indication de la présence d'autres pages successives.

Les pages qui suivent reportent, elles aussi, les indications concernant les points A - C - D - E - G et H.

E. Seitenzahl und Gesamtzahl der Seiten, die für die Beschreibung der Gruppe erforderlich sind.

F. Explosionszeichnung der Gruppe.

G. Vollständige Beschreibung der Einzelteile, mit Kodenummer und Menge der Teile.

H. Angabe über die Präsenz weiterer folgender Seiten.

Auf den nachfolgenden Seiten sind die Bezeichnungen, die sich auf die Punkte A - C - D - E - G und H beziehen, erneut wiedergegeben.

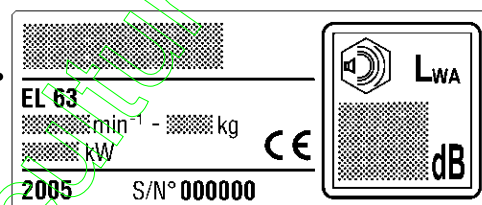
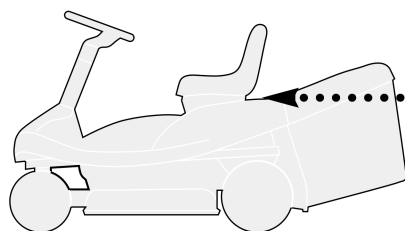

3. Ordine di ricambi

Prima di formulare un ordine di ricambi, accertare che il catalogo corrisponda all'anno di costruzione della macchina, riportato sulla targhetta di identificazione.

Ogni ordine di ricambi deve necessariamente contenere:

- modello della macchina;
- quantità di pezzi richiesta;
- descrizione (eventuale);
- numero di codice del pezzo;
- destinatario;
- mezzo di spedizione.

Esempio di ordinazione:

Su una macchina EL63 del 2005 con motore B&S, si deve sostituire il tubo di scarico. Tale particolare è raffigurato nella tavola **005.0** alla posizione **6**, a cui corrisponde il codice **84869053/0**.

L'ordinazione sarà quindi:

per EL63:
n. 1 tubo scarico
cod. 84869053/0
da inviare a
a mezzo

Nota

Per le parti non codificate del motore e della trasmissione contrassegnate con (*), occorre rivolgersi al Costruttore.

3. Spare parts order

Before putting in an order for spare parts, make sure that the catalogue is the one applying to the machine's year of manufacture, as shown on the identification plate attached to the machine.

Each spare parts order must include:

- the model of the machine;
- the number of parts required;
- description (incidental);
- the code number for the item;
- the destination;
- the method of shipping.

An example of an order:

The exhaust tube on a EL63 machine with B&S engine, produced in 2005, must be replaced. This part is shown in table **005.0** in position **6**, and has the code number **84869053/0**.

The order will therefore be:

for EL63:
1 exhaust tube
code 84869053/0
to be sent to
method of shipping

Note

For parts of the engine and the transmission without code numbers, marked by (*), it's necessary to contact the manufacturer.

3. Commande pièces détachées

Avant de passer une commande pour des pièces détachées, s'assurer que le catalogue est celui correspondant à l'année de fabrication de la machine reportée sur la plaquette d'identification.

Chaque commande de pièces détachées doit obligatoirement contenir:

- modèle de la machine;
- quantité de pièces demandée;
- description (éventuelle);
- numéro de code de la pièce;
- le destinataire;
- le moyen de transport.

Exemple de commande:

Sur une machine EL63 du 2005 avec moteur B&S, il faut remplacer le tube de échappement. Cette pièce est représentée sur le tableau **005.0** à la position **6**, correspondant au code **84869053/0**.

La commande sera donc formulée de la façon suivante:

pour EL63:
1 tube de échappement
code 84869053/0
à envoyer à
par

Remarque

Pour les pièces non codées du moteur et de la transmission, indiquées avec (*), il faut s'adresser au Fabricant.

3. Ersatzteilbestellungen

Ehe eine Ersatzteilbestellung geschrieben wird, muß man sich vergewissern, daß der Katalog mit dem Herstellungsjahr der Maschine übereinstimmt, auf dem Kennzeichenschild wiedergegeben.

Jede Ersatzteilbestellung muß enthalten:

- Modell der Maschine;
- Menge der angeforderten Teile;
- Bezeichnung (eventuell);
- Artikelnummer des Teils;
- Empfänger;
- Versandart.

Beispiel einer Bestellung:

Auf einer Maschine EL63 von 2005 mit Motor B&S, muß das Rohr für Apgasung ersetzt werden. Dieses Einzelteil ist auf der Tafel **005.0** unter der Position **6**, dargestellt, der dem Code **84869053/0** entspricht.

Die Bestellung lautet demnach:

Für EL63:
1 Rohr für Apgasung
Kode 84869053/0
zu versenden an
mit

Anmerkung

Für die nicht codierten Teile des Motors und des Antriebs, die mit (*) gekennzeichnet sind, muß man sich an den Hersteller wenden.

EL63

EL63 M

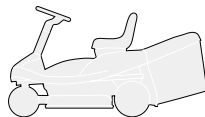







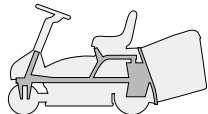
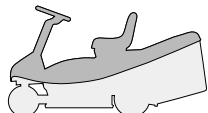

INDICE DELLE TAVOLE
INDEX OF TABLES
SOMMAIRE DES TABLEAUX
INHALT DER TAFELN

2005

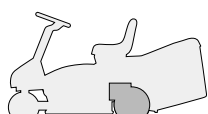
000.0

3 / 6

GRUPPO / UNIT / GROUPE / GRUPPE	EL63	EL63 M
 <p>TELAIO CHASSIS CHASSIS RAHMENSATZ</p>	001	001
 <p>CARROZZERIA BODY CARROSSERIE KARROSSERIE</p>	002	002
 <p>STERZO STEERING BARRE DE DIRECTION LENKGETRIEBE</p>	003	003
 <p>COMANDO FRENO E COMANDO CAMBIO BRAKE AND GEARBOX CONTROLS COMMANDE FREIN ET BOITE DE VITESSE BREMSE UND WECHSEL ANTRIEB</p>	004	004
 <p>MOTORE ENGINE MOTEUR MOTOR B&S</p> <p>TECUMSEH</p>	005 005a	005 005a
 <p>TRASMISSIONE TRANSMISSION TRANSMISSION GETRIEBE</p>	006	006
 <p>SOLLEVAMENTO PIATTO DI TAGLIO CUTTING PLATE LIFTING SOULEVEMENT PLATEAU DE COUPE SCHNEIDWERKZEUG AUFHEBESATZ</p>	007	007
 <p>PIATTO DI TAGLIO (1) CUTTING PLATE (1) PLATEAU DE COUPE (1) SCHNEIDWERKZEUG (1) con / with / avec / mit B&S</p> <p>con / with / avec / mit TECUMSEH</p>	008 008a	008 008a
 <p>PIATTO DI TAGLIO (2) CUTTING PLATE (2) PLATEAU DE COUPE (2) SCHNEIDWERKZEUG (2)</p>	009	009

GRUPPO / UNIT / GROUPE / GRUPPE	EL63	EL63 M
---------------------------------	------	--------

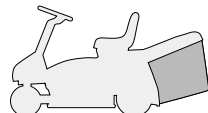

SACCO
GRASSCATCHER
BAC
AUFFANGSACK

010**010**

PARTI ELETTRICHE
ELECTRICAL PARTS
PARTIES ELECTRIQUES
ELETRISCHE TEILE

011**011a**

ACCESSORI A RICHIESTA
OPTIONALS ON REQUEST
ACCESSOIRES SUR DEMANDE
ZUBEHOERE NACH ANFRAGE.....

012**012**

ETICHETTE
LABELS
ETIQUETTES
KLEBZETTEL

013**013**

contact@emc-motoculture.com

EL63

EL63 M

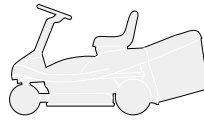

ELENCO NUMERICO
NUMERICAL LIST
LISTE NUMERIQUE
NUMERISCHE AUFSTELLUNG

2005

000.1

5 / 6

CODE	TABLE	N.	Q.TY	CODE	TABLE	N.	Q.TY	CODE	TABLE	N.	Q.TY
12000970/0	003.0	36	1	12521350/0	008a.0	24	1	12789020/0	010.0	8	4
12000970/0	003.0	57	2	12521360/0	007.0	28	2	12789100/0	002.0	49	2
12001010/0	003.0	6	1	12521370/0	003.0	9	1	12789210/0	010.0	10	2
12001010/0	006.0	57	2	12521390/0	003.0	56	2	12791011/0	001.0	23	1
12139100/0	006.0	2	1	12521410/0	006.0	55	2	12791011/0	006.0	74	1
12141818/0	003.0	24	1	12523040/0	002.0	4	4	12791200/0	004.0	6	2
12154210/0	004.0	4	1	12523040/0	002.0	22	2	12791200/0	006.0	82	2
12154210/0	005.0	5	1	12523040/0	006.0	83	2	12791200/0	008.0	2	2
12154210/0	005.0	9	1	12523040/0	011.0	20	1	12791200/0	008a.0	2	2
12154210/0	005a.0	3	3	12523060/0	001.0	68	1	12791500/0	001.0	26	2
12154210/0	006.0	33	4	12523060/0	001.0	77	1	12791500/0	002.0	24	1
12154210/0	006.0	88	1	12523060/0	002.0	45	4	12792099/0	001.0	20	2
12154210/0	008a.0	25	1	12523060/0	004.0	16	1	12792611/0	009.0	22	1
12154250/0	007.0	29	1	12523060/0	006.0	9	1	12793101/0	002.0	43	4
12154330/0	002.0	50	2	12523060/0	008a.0	23	1	12793102/0	003.0	38	1
12154330/0	008.0	13	1	12523060/0	009.0	38	4	12793102/0	009.0	37	2
12154330/0	008a.0	13	1	12523065/0	003.0	15	1	12793701/0	001.0	16	1
12154330/0	010.0	7	2	12523070/0	006.0	12	1	12793701/0	005.0	4	1
12154330/0	010.0	9	4	12523070/0	006.0	59	1	12793701/0	006.0	39	1
12154330/0	010.0	12	2	12523100/0	003.0	43	2	12794110/0	009.0	34	2
12154330/0	010.0	15	2	12530060/0	002.0	23	1	12794970/0	007.0	27	1
12154510/0	001.0	24	1	12540040/0	006.0	75	1	12815200/0	009.0	6	4
12154510/0	002.0	25	1	12540070/0	009.0	35	2	12815210/0	009.0	27	1
12154510/0	003.0	27	2	12583500/0	002.0	44	4	12818690/0	001.0	36	2
12154510/0	004.0	37	1	12587100/0	003.0	45	1	12818690/0	009.0	10	2
12154510/0	007.0	9	1	12604899/0	003.0	41	2	12818690/0	009.0	13	2
12154510/0	008.0	3	2	12620305/0	002.0	62	1	12818690/0	009.0	16	2
12154510/0	008a.0	3	2	12622650/0	003.0	7	1	12818690/0	009.0	19	2
12154510/0	009.0	28	1	12622651/0	002.0	95	1	14356699/0	013.0	2	1
12155000/0	001.0	38	2	12674530/0	010.0	13	2	14357428/0	013.0	1	1
12155000/0	001.0	65	1	12674700/0	004.0	36	1	14358415/0	013.0	3	1
12155000/0	001.0	69	1	12674700/0	007.0	8	1	14358416/0	013.0	8	1
12155000/0	001.0	78	1	12689515/0	003.0	26	2	14358417/0	013.0	7	1
12155000/0	003.0	25	1	12691100/0	005.0	8	1	14358418/0	013.0	5	1
12155000/0	003.0	28	1	12691115/0	001.0	64	1	14358460/0	013.0	6	1
12155000/0	003.0	39	1	12691200/0	001.0	67	1	14358654/0	013.0	9	1
12155000/0	004.0	12	1	12691200/0	001.0	76	1	14358717/0	013.0	4	1
12155000/0	004.0	41	1	12691200/0	006.0	8	1	14358731/0	002.0	94	1
12155000/0	005.0	3	1	12691400/0	005a.0	2	3	14360118/0	013.0	10	1
12155000/0	006.0	10	1	12691800/0	005.0	2	1	18120004/0	011.0	14	1
12155000/0	006.0	14	1	12692050/0	006.0	32	3	18210016/0	011.0	7	1
12155000/0	006.0	36	2	12692695/0	003.0	42	1	18375051/1	005.0	13	2
12155000/0	006.0	38	2	12727810/0	002.0	73	2	18375051/1	005a.0	12	4
12155000/0	007.0	35	1	12728530/0	009.0	32	5	18399065/1	008.0	32	1
12155000/0	007.0	37	1	12729600/0	001.0	44	2	18399065/1	008a.0	32	1
12155000/0	008.0	7	1	12729600/0	004.0	33	5	18399066/1	008.0	33	1
12155000/0	008a.0	7	1	12729600/0	007.0	4	4	18399066/1	008a.0	33	1
12155000/0	009.0	23	1	12729600/0	007.0	11	1	18400861/0	011.0	5	1
12155010/0	009.0	39	2	12731350/0	007.0	21	4	18400970/1	006.0	31	1
12156602/0	003.0	20	1	12735104/0	006.0	46	2	18400971/0	006.0	72	1
12156602/0	007.0	15	1	12735105/0	001.0	13	2	18400972/0	006.0	71	1
12156602/0	007.0	17	1	12735105/0	002.0	27	2	18450065/1	011.0	4	1
12156602/0	007.0	25	1	12735106/0	001.0	72	2	18564861/1	011.0	16	1
12156602/0	007.0	31	1	12735110/0	011.0	9	2	18565351/0	011.0	6	1
12292102/0	004.0	14	2	12735110/0	012.0	8	2	18718000/0	005.0	21	1
12292102/0	006.0	84	2	12735111/0	005.0	7	4	18718000/0	005a.0	21	1
12292102/0	009.0	8	4	12735121/0	001.0	5	6	18736111/0	011.0	8	1
12293200/0	003.0	16	1	12735121/0	001.0	7	10	18737852/0	003.0	32	2
12293200/0	006.0	19	2	12735121/0	001.0	9	4	18738201/0	005a.0	4	1
12293200/0	007.0	34	1	12735121/0	001.0	11	6	19035000/0	009.0	3	1
12293201/0	001.0	18	1	12735121/0	001.0	15	2	19410606/0	011.0	13	3
12293201/0	006.0	40	1	12735121/0	001.0	28	1	19410606/0	011a.0	5	4
12293201/0	006.0	60	2	12735121/0	001.0	32	4	19410612/0	011.0	21	1
12293201/0	009.0	11	2	12735121/0	001.0	34	4	19410612/0	011a.0	8	1
12293201/0	009.0	14	2	12735121/0	001.0	46	2	19700046/0	011.0	12	1
12293201/0	009.0	17	2	12735121/0	001.0	62	1	19700046/0	011a.0	4	1
12293201/0	009.0	20	2	12735121/0	006.0	16	2	19700047/0	006.0	70	1
12295200/0	007.0	14	1	12735148/0	005a.0	5	4	19700048/0	006.0	66	1
12295200/0	007.0	26	1	12735402/0	002.0	5	2	19700049/0	006.0	68	1
12295300/0	003.0	46	1	12735402/0	009.0	53	5	19700050/0	006.0	62	1
12360352/0	011.0	10	2	12735410/0	002.0	3	4	19700051/0	006.0	63	1
12436030/0	003.0	10	1	12735410/0	009.0	55	2	19700052/0	006.0	65	2
12437503/0	002.0	93	1	12735410/0	012.0	4	3	19700053/0	006.0	64	1
12500030/0	009.0	4	1	12735460/0	008.0	34	1	19700054/0	006.0	67	1
12521330/0	009.0	41	1	12735460/0	008a.0	34	1	19700055/0	006.0	69	1
12521331/0	010.0	11	2	12735598/0	002.0	92	1	19700056/0	006.0	61	3
12521331/0	010.0	14	2	12789020/0	008.0	12	1	21660100/0	008.0	9	2
12521350/0	001.0	37	2	12789020/0	008a.0	12	1	21660100/0	008a.0	9	2
12521350/0	004.0	3	1	12789020/0	010.0	6	2	22170910/0	001.0	74	1





CODE	TABLE	N.	Q.TY	CODE	TABLE	N.	Q.TY	CODE	TABLE	N.	Q.TY
22450110/0	008.0	36	1	27110370/0	002.0	7	1	27772131/0	001.0	35	2
22450110/0	008a.0	36	1	27110374/0	002.0	2	1	27772133/0	009.0	12	1
22524970/2	006.0	86	1	27110375/1	002.0	1	1	27772139/0	012.0	7	1
22672152/0	003.0	14	1	27110377/1	002.0	7	1	27772145/0	006.0	85	1
22672152/0	008.0	6	1	27110378/1	002.0	1	1	27773077/0	001.0	22	1
22672152/0	008a.0	6	1	27110379/0	002.0	1	1	27787041/0	003.0	37	1
22680009/0	006.0	76	1	27110398/0	002.0	7	1	27787045/1	009.0	33	1
22746601/0	003.0	22	1	27110422/0	002.0	1	1	27787057/0	002.0	81	1
22746601/0	004.0	40	1	27110424/0	002.0	1	1	27790000/0	002.0	84	1
22981467/0	002.0	26	1	27110425/0	002.0	1	1	27790010/1	002.0	91	1
24487995/0	008a.0	18	1	27140052/0	012.0	2	1	27840051/0	003.0	40	1
24487997/0	002.0	47	1	27140053/0	009.0	52	1	27840053/0	006.0	34	1
24487997/0	004.0	42	1	27230200/2	009.0	26	1	27864052/0	002.0	46	1
24487997/0	007.0	18	1	27230201/0	012.0	3	1	27869057/0	001.0	19	1
24487997/0	007.0	23	1	27275000/0	009.0	40	1	27943051/0	008a.0	28	1
24487997/0	007.0	38	1	27315105/0	006.0	73	1	27961230/0	002.0	61	1
24487997/0	009.0	30	2	27340305/1	003.0	1	1	33320505/0	011.0	18	5
24487998/0	008.0	10	1	27394000/0	002.0	8	1	33320506/0	011a.0	6	6
24487998/0	008a.0	10	1	27395050/1	004.0	10	1	33340033/0	011.0	3	1
24487998/0	012.0	6	1	27430564/0	004.0	13	1	35061406/0	006.0	3	1
25033060/0	009.0	2	1	27430567/0	001.0	41	1	38780530/2	005.0	11	1
25110269/0	004.0	7	1	27430568/0	007.0	5	1	81003375/1	001.0	66	1
25120230/0	002.0	64	1	27430569/1	001.0	42	1	81003375/1	001.0	75	1
25160016/0	003.0	44	1	27430570/0	004.0	35	1	81007280/2	002.0	21	1
25394510/0	004.0	38	1	27430572/0	011.0	15	1	82180051/0	011.0	19	1
25394510/0	007.0	7	1	27430574/0	007.0	10	1	82180053/0	011.0	19	1
25394510/0	008.0	15	1	27430579/0	008.0	35	1	84000252/0	002.0	28	1
25394510/0	008a.0	15	1	27430579/0	008a.0	35	1	84000253/0	002.0	28	1
25430208/0	001.0	70	1	27430585/0	008a.0	19	1	84001017/0	007.0	1	1
25430219/0	006.0	17	1	27430585/0	008a.0	26	1	84001019/0	007.0	19	1
25430239/1	011.0	17	1	27487001/0	008.0	1	1	84001021/0	004.0	31	1
25510007/1	007.0	24	1	27487003/0	008a.0	1	1	84002073/0	007.0	12	1
25510022/0	012.0	5	1	27500051/0	004.0	1	1	84034059/0	003.0	31	1
25510040/1	007.0	33	1	27500057/0	008a.0	27	1	84040122/0	011a.0	1	1
25510056/0	003.0	17	1	27510097/1	009.0	29	1	84040123/0	011.0	1	1
25510056/0	007.0	13	1	27510107/0	008.0	4	1	84040125/0	011.0	1	1
25547037/1	007.0	3	1	27510107/0	008a.0	4	1	84044001/0	006.0	52	2
25670005/1	006.0	56	2	27520052/0	003.0	4	1	84044002/0	003.0	52	2
25670008/1	003.0	18	2	27546015/1	004.0	32	2	84106055/0	010.0	5	1
25670008/1	003.0	23	2	27546015/1	007.0	2	1	84109504/0	009.0	36	1
25670008/1	007.0	16	4	27546015/1	007.0	20	2	84180186/0	010.0	16	1
25670008/1	007.0	22	2	27546029/0	006.0	15	1	84207103/2	006.0	4	1
25670008/1	007.0	30	2	27546039/1	002.0	42	1	84207104/1	008.0	31	1
25670011/0	004.0	11	2	27546041/0	009.0	24	1	84207104/1	008a.0	31	1
25670011/0	004.0	43	1	27546043/0	009.0	25	1	84207105/0	004.0	8	1
25670011/0	006.0	13	1	27570050/0	003.0	8	1	84230405/0	003.0	34	1
25670011/0	006.0	87	1	27590054/0	003.0	54	2	84230407/0	003.0	35	1
25670011/0	007.0	36	3	27590055/0	006.0	53	2	84250051/0	006.0	41	1
25670011/0	008.0	5	1	27590056/0	003.0	55	2	84317071/0	004.0	34	1
25670011/0	008a.0	5	1	27590057/0	006.0	54	2	84317073/0	008a.0	8	1
25722453/1	002.0	41	1	27600113/0	002.0	83	1	84317073/1	008.0	8	1
25722463/0	002.0	101	1	27600114/1	002.0	63	1	84317075/0	007.0	6	1
25755013/0	001.0	27	1	27600118/0	002.0	72	1	84317077/0	006.0	5	1
25840005/0	006.0	18	1	27600119/0	002.0	71	1	84317079/0	008.0	14	1
25869017/1	005a.0	11	1	27600122/0	009.0	31	1	84317079/0	008a.0	14	1
25943001/0	006.0	35	1	27600139/0	005a.0	6	1	84318401/0	001.0	1	1
25961211/0	002.0	102	1	27604006/2	006.0	1	1	84318403/0	001.0	2	1
27034063/0	004.0	39	1	27604007/0	006.0	6	1	84394051/0	010.0	4	1
27034064/1	004.0	9	1	27650111/0	001.0	33	2	84394830/0	006.0	45	1
27034065/0	007.0	32	1	27650115/1	001.0	6	2	84503005/0	004.0	5	1
27034066/2	003.0	21	1	27650117/0	010.0	3	2	84503009/0	008a.0	20	1
27034076/0	006.0	89	1	27650119/0	006.0	37	2	84545061/0	001.0	31	1
27034082/0	008a.0	17	1	27650120/0	009.0	54	1	84545063/0	009.0	21	1
27045070/0	003.0	53	4	27670054/0	003.0	13	1	84564095/0	009.0	1	1
27045071/0	008a.0	16	1	27670054/0	003.0	29	1	84650103/0	009.0	5	1
27047004/0	003.0	5	2	27670054/0	004.0	2	2	84650105/0	001.0	8	1
27047004/0	003.0	12	2	27670054/0	006.0	11	1	84680056/0	003.0	51	2
27047004/0	003.0	33	4	27670054/0	008a.0	21	2	84680057/0	006.0	51	2
27047005/1	003.0	2	1	27670055/0	004.0	15	1	84735553/1	003.0	11	1
27047007/0	006.0	7	1	27670056/0	008a.0	22	1	84783015/1	001.0	3	1
27063021/1	002.0	48	1	27722354/0	011.0	2	1	84783017/2	001.0	10	1
27065060/0	011.0	11	1	27722355/0	011a.0	2	1	84783023/1	001.0	63	1
27065060/0	011a.0	3	1	27722356/0	011a.0	2	1	84783029/1	001.0	63	1
27065061/0	011a.0	7	1	27733002/1	002.0	82	1	84783033/0	001.0	10	1
27065064/0	011a.0	7	1	27734059/0	001.0	45	1	84801117/1	001.0	14	1
27065065/0	011a.0	9	1	27753071/0	009.0	18	2	84801119/0	010.0	2	1
27107502/0	009.0	51	1	27753073/0	001.0	43	2	84801121/0	010.0	1	1
27110355/1	002.0	1	1	27753075/0	001.0	61	1	84801125/0	001.0	73	1
27110356/1	002.0	2	1	27753079/0	006.0	81	1	84869053/0	005.0	6	1
27110357/1	002.0	7	1	27753081/0	001.0	25	1	99900035/0	012.0	1	1
27110362/0	002.0	1	1	27772095/0	001.0	12	1				
27110363/0	002.0	2	1	27772095/0	001.0	71	1				
27110364/0	002.0	7	1	27772119/0	009.0	9	1				
27110368/0	002.0	1	1	27772121/0	001.0	4	2				
27110369/0	002.0	2	1	27772127/1	009.0	15	1				

EL63
EL63 M

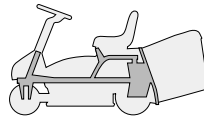

TELAIO
CHASSIS
CHASSIS
RAHMENSATZ

2005

001.0

1 / 2

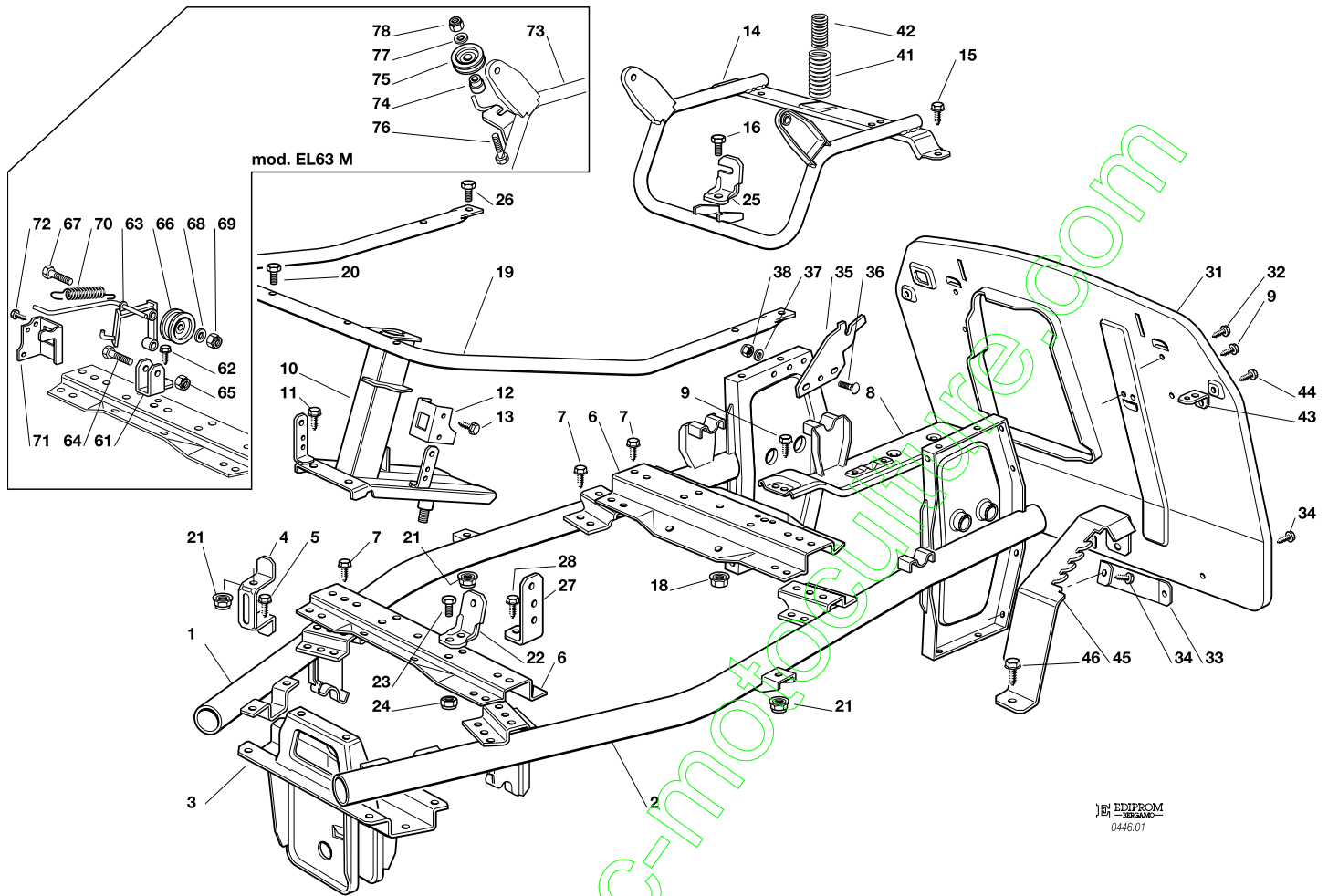

EDIPROM
0446.01

N.	CODE	Q.TY	DESCRIZIONE	DESCRIPTION	DESCRIPTION	BESCHREIBUNG
1	84318401/0	1	LONGHERONE DX	SIDE FRAME, RIGHT	LONGERON, DROIT	LÄNGSTRÄGER, RECHTER
2	84318403/0	1	LONGHERONE SX	SIDE FRAME, LEFT	LONGERON, GAUCHE	LÄNGSTRÄGER, LINKER
3	84783015/1	1	SUPPORTO AVANTRENO	SUPPORT	SUPPORT	HALTER
4	27772121/0	2	STAFFA	CLAMP	ETRIER	BRIDE
5	12735121/0	6	VITE	SCREW	VIS	SCHRAUBE
6	27650115/1	2	RINFORZO CENTRALE	STIFFENING	REINFORCEMENT	VERSTAERKUNG
7	12735121/0	10	VITE	SCREW	VIS	SCHRAUBE
8	84650105/0	1	RINFORZO	STIFFENING	REINFORCEMENT	VERSTAERKUNG
9	12735121/0	4	VITE	SCREW	VIS	SCHRAUBE
10	84783017/2	1	SUPP. PIANTONE (B&S)	SUPPORT (B&S)	SUPPORT (B&S)	HALTER (B&S)
	84783033/0	1	SUPP. PIANTONE (Tecumseh)	SUPPORT (Tecumseh)	SUPPORT (Tecumseh)	HALTER (Tecumseh)
11	12735121/0	6	VITE	SCREW	VIS	SCHRAUBE
12	27772095/0	1	SUPPORTO MICRO LAMA	SUPPORT	SUPPORT	HALTER
13	12735105/0	2	VITE	SCREW	VIS	SCHRAUBE
15	12735121/0	2	VITE	SCREW	VIS	SCHRAUBE
16	12793701/0	1	VITE	SCREW	VIS	SCHRAUBE
18	12293201/0	1	DADO	NUT	ECROU	MUTTER
19	27869057/0	1	SUPPORTO PEDANE	SUPPORT	SUPPORT	HALTER
20	12792099/0	2	VITE	SCREW	VIS	SCHRAUBE
21	12154510/0	4	DADO	NUT	ECROU	MUTTER
22	27773077/0	1	SQUADRETTA	ANGLE BRACKET	EQUERRE	WINKEL
23	12791011/0	1	VITE	SCREW	VIS	SCHRAUBE
24	12154510/0	1	DADO	NUT	ECROU	MUTTER
25	27753081/0	1	SQUADRETTA	ANGLE BRACKET	EQUERRE	WINKEL
26	12791500/0	2	VITE	SCREW	VIS	SCHRAUBE
27	25755013/0	1	SQUADRETTA (Tecumseh)	ANGLE BRACKET (Tecumseh)	EQUERRE (Tecumseh)	WINKEL (Tecumseh)
28	12735121/0	1	VITE (Tecumseh)	SCREW (Tecumseh)	VIS (Tecumseh)	SCHRAUBE (Tecumseh)
31	84545061/0	1	PIASTRA POSTERIORE	REAR PLATE	PLAQUE ARRIERE	HINTERE PLATTE
32	12735121/0	4	VITE	SCREW	VIS	SCHRAUBE
33	27650111/0	2	RINFORZO	STIFFENING	REINFORCEMENT	VERSTAERKUNG





N.	CODE	Q.TY	DESCRIZIONE	DESCRIPTION	DESCRIPTION	BESCHREIBUNG
34	12735121/0	4	VITE	SCREW	VIS	SCHRAUBE
35	27772131/0	2	STAFFA	CLAMP	ETRIER	BRIDE
36	12818690/0	2	VITE	SCREW	VIS	SCHRAUBE
37	12521350/0	2	RONDELLA	WASHER	RONDELLE	SCHEIBE
38	12155000/0	2	DADO	NUT	ECROU	MUTTER
41	27430567/0	1	MOLLA	SPRING	RESSORT	FEDER
42	27430569/1	1	MOLLA	SPRING	RESSORT	FEDER
43	27753073/0	2	SQUADRETTA	ANGLE BRACKET	EQUERRE	WINKEL
44	12729600/0	2	VITE	SCREW	VIS	SCHRAUBE
45	27734059/0	1	SETTORE SOLLEVAMENTO	RACK	CREMAILLIERE	ZAHNSCHIENE
46	12735121/0	2	VITE	SCREW	VIS	SCHRAUBE
			Nei modelli con avviamento elettrico:	For models with electric start:	Dans les modèles avec démarrage électrique:	Bei Modellen mit elektrischem Anlassen:
14	84801117/1	1	SUPPORTO SEDILE	SUPPORT	SUPPORT	HALTER
			Nei modelli con avviamento manuale:	For models with manual start:	Dans les modèles avec démarrage manuel:	Bei Modellen mit Anlassen von Hand:
61	27753075/0	1	SQUADRETTA	ANGLE BRACKET	EQUERRE	WINKEL
62	12735121/0	1	VITE	SCREW	VIS	SCHRAUBE
63	84783023/1	1	SUPP. RUOTINO (B&S)	SUPPORT (B&S)	SUPPORT (B&S)	HALTER (B&S)
	84783029/1	1	SUPP. RUOTINO (Tecumseh)	SUPPORT (Tecumseh)	SUPPORT (Tecumseh)	HALTER (Tecumseh)
64	12691115/0	1	VITE	SCREW	VIS	SCHRAUBE
65	12155000/0	1	DADO	NUT	ECROU	MUTTER
66	81003375/1	1	RUOTINO	WHEEL	ROULETTES	RAEDCHEN
67	12691200/0	1	VITE	SCREW	VIS	SCHRAUBE
68	12523060/0	1	RONDELLA	WASHER	RONDELLE	SCHEIBE
69	12155000/0	1	DADO	NUT	ECROU	MUTTER
70	25430208/0	1	MOLLA	SPRING	RESSORT	FEDER
71	27772095/0	1	SUPPORTO MICRO	SUPPORT	SUPPORT	HALTER
72	12735106/0	2	VITE	SCREW	VIS	SCHRAUBE
73	84801125/0	1	SUPPORTO SEDILE (B&S)	SUPPORT (B&S)	SUPPORT (B&S)	HALTER (B&S)
74	22170910/0	1	PERNO (B&S)	PIN (B&S)	PIVOT (B&S)	BOLZEN (B&S)
75	81003375/1	1	RUOTINO (B&S)	WHEEL (B&S)	ROULETTES (B&S)	RAEDCHEN (B&S)
76	12691200/0	1	VITE (B&S)	SCREW (B&S)	VIS (B&S)	SCHRAUBE (B&S)
77	12523060/0	1	RONDELLA (B&S)	WASHER (B&S)	RONDELLE (B&S)	SCHEIBE (B&S)
78	12155000/0	1	DADO (B&S)	NUT (B&S)	ECROU (B&S)	MUTTER (B&S)

contact@ebs-motoculture.com

EL63

EL63 M

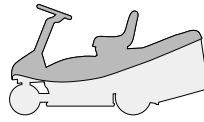

CARROZZERIA
BODY
CARROSSERIE
KARROSSERIE

2005

002.0

1 / 2

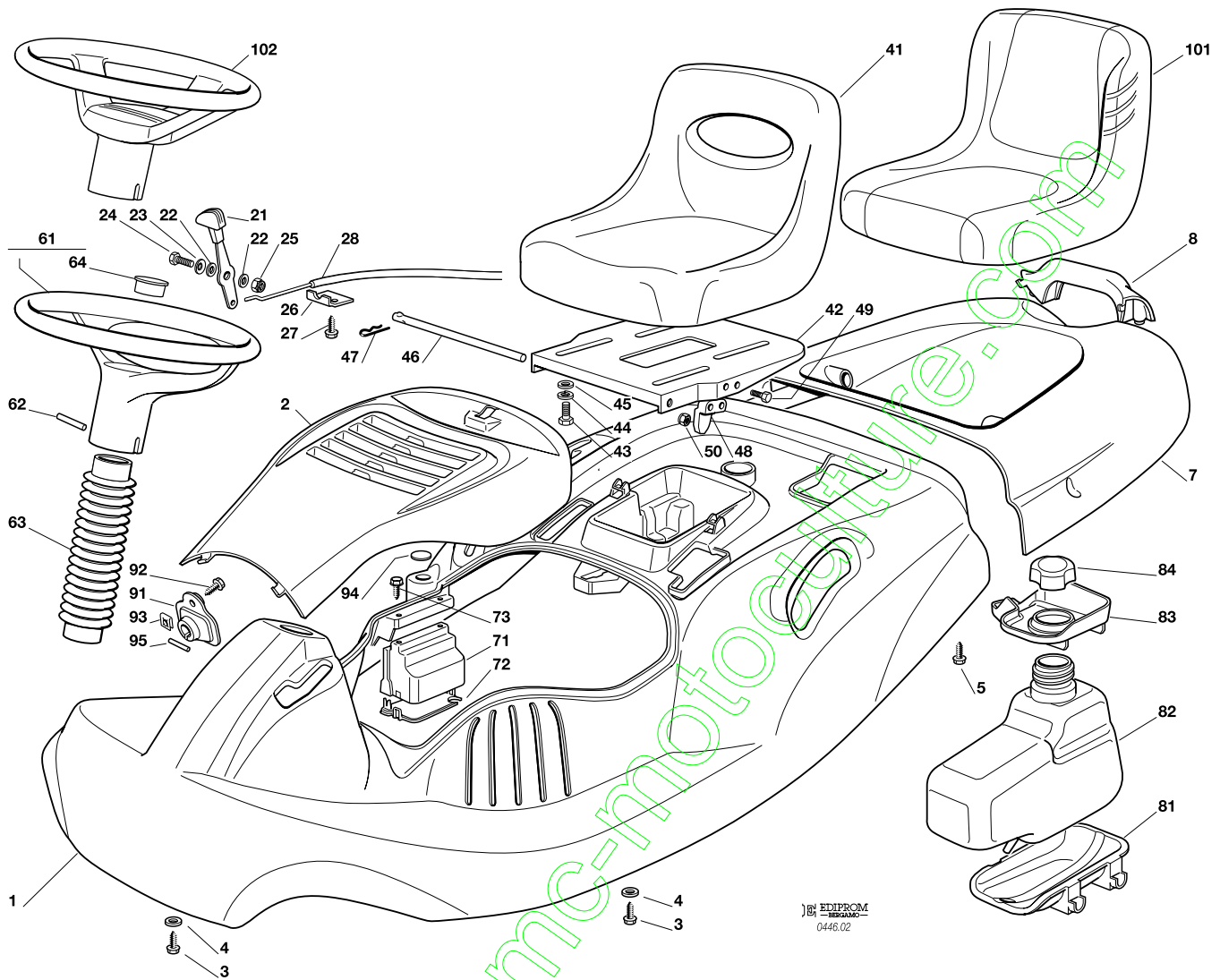

EDIPROM
0446.02

N.	CODE	Q.TY	DESCRIZIONE	DESCRIPTION	DESCRIPTION	BESCHREIBUNG
2		1	COPERTURA MOTORE	ENGINE COVER	COUVRE MOTEUR	MOTORKAPPE
	27110356/1	1	ROSSO	RED	ROUGE	ROT
	27110363/0	1	VERDE	GREEN	VERT	GRÜN
	27110376/1	1	ARANCIONE	ORANGE	ORANGE	DUNKELORANGE
	27110369/0	1	BLU	BLUE	BLEU	BLAU
	27110374/0	1	NERA	BLACK	NOIR	SCHWARZ
3	12735410/0	4	VITE	SCREW	VIS	SCHRAUBE
4	12523040/0	4	ROSETTA			
5	12735402/0	2	VITE	SCREW	VIS	SCHRAUBE
7		1	COPERTURA SACCO	GRASS-CATCHER COVER,	COUVRE-BAC	SACKKAPPE
	27110357/1		ROSSO	RED	ROUGE	ROT
	27110364/0		VERDE	GREEN	VERT	GRÜN
	27110377/1		ARANCIONE	ORANGE	ORANGE	DUNKELORANGE
	27110370/0		BLU	BLUE	BLEU	BLAU
	27110398/0		NERO	BLACK	NOIR	SCHWARZ
8	27394000/0	1	MANIGLIA	HANDLE	POIGNEE	GRIFF
21	81007280/2	1	LEVA ACCELERATORE	ACCELERATOR LEVER	LEVIER ACCELERATEUR	GASHEBEL
22	12523040/0	2	ROSETTA	WASHER	RONDELLE	SCHEIBE
23	12530060/0	1	ROSETTA	WASHER	RONDELLE	SCHEIBE
24	12791500/0	1	VITE	SCREW	VIS	SCHRAUBE
25	12154510/0	1	DADO	NUT	ECROU	MUTTER
26	22981467/0	1	PIASTRINA	PLATE	PLAQUE	PLATTE
27	12735105/0	2	VITE	SCREW	VIS	SCHRAUBE
28	84000252/0	1	CAVO ACCELER. (B&S)	THROTTLE CABLE (B&S)	CABLE ACCELER. (B&S)	GASHEBEL KABEL (B&S)
	84000253/0	1	CAVO ACCELER. (Tecumseh)	THROTTLE CABLE (Tecumseh)	CABLE ACCELER. (Tecumseh)	GASHEBEL KABEL (Tecumseh)





N.	CODE	Q.TY	DESCRIZIONE	DESCRIPTION	DESCRIPTION	BESCHREIBUNG
41	25722453/1	1	SEDILE	SEAT	SIEGE	SITZ
42	27546039/1	1	SUPPORTO SEDILE	SUPPORT	SUPPORT	HALTER
43	12793101/0	4	VITE	SCREW	VIS	SCHRAUBE
44	12583500/0	4	GROWER	GROWER	GROWER	GROWER
45	12523060/0	4	RONDELLA	WASHER	RONDELLE	SCHEIBE
46	27864052/0	1	PERNO SEDILE	PIN	PIVOT	BOLZEN
47	24487997/0	1	COPPIGLIA	COTTER PIN	GOUPILLE	SPLIT
48	27063021/1	1	CAMMA	CAM	CAME	NOCKEN
49	12789100/0	2	VITE	SCREW	VIS	SCHRAUBE
50	12154330/0	2	DADO	NUT	ECROU	MUTTER
61	27961230/0	1	VOLANTE	STEERING WHEEL	VOLANT	LENKRAD
62	12620305/0	1	SPINA	PIN	GOUPILLE	STIFT
63	27600114/1	1	PROTEZIONE	GUARD	PROTECTION	SCHUTZ
64	25120230/0	1	TAPPO	CAP	BOUCHON	STOPFEN
71	27600119/0	1	PROTEZIONE SCHEDA	GUARD	PROTECTION	SCHUTZ
72	27600118/0	1	PROTEZIONE SCHEDA	GUARD	PROTECTION	SCHUTZ
73	12727810/0	2	VITE	SCREW	VIS	SCHRAUBE
81	27787057/0	1	SUPPORTO	SUPPORT	SUPPORT	HALTER
82	27733002/1	1	SERBATOIO	TANK	RESERVOIR	TANK
83	27600113/0	1	PROTEZIONE BENZINA	GUARD	PROTECTION	SCHUTZ
84	27790000/0	1	TAPPO SERBATOIO	CAP	BOUCHON	TANKVERSCHLUSS
101	25722463/0	1	SEDILE COMFORT	SEAT, COMFORT	SIEGE, COMFORT	SITZ, COMFORT
102	25961211/0	1	VOLANTE GRIGIO	STEERING WHEEL, GRAY	VOLANT GRIS	LENKRAD, GRAU

**Nei modelli
con avviamento elettrico:**

**For models
with electric start:**

**Dans les modèles avec
démarrage électrique:**

**Bei Modellen mit
elektrischem Anlassen:**

1	•	1	COPERTURA RUOTE	WHEELS COVER	COUVRE ROUES	RADENKAPPE
	27110355/1		ROSSO (B&S)	RED (B&S)	ROUGE (B&S)	ROT (B&S)
	27110422/0		ROSSO (Tecumseh)	RED (Tecumseh)	ROUGE (Tecumseh)	ROT (Tecumseh)
	27110362/0		VERDE (B&S)	GREEN (B&S)	VERT (B&S)	GRÜN (B&S)
	27110375/1		ARANCIONE (B&S)	ORANGE (B&S)	ORANGE (B&S)	DUNKELORANGE (B&S)
	27110424/0		ARANCIONE (Tecumseh)	ORANGE (Tecumseh)	ORANGE (Tecumseh)	DUNKELORANGE (Tecumseh)
	27110368/0		BLU (B&S)	BLUE (B&S)	BLEU (B&S)	BLAU (B&S)

**Nei modelli
con avviamento manuale:**

**For models
with manual start:**

**Dans les modèles avec
démarrage manuel:**

**Bei Modellen mit
Anlassen von Hand:**

1	•	1	COPERTURA RUOTE	WHEELS COVER	COUVRE ROUES	RADENKAPPE
	27110378/1		ROSSO (B&S)	RED (B&S)	ROUGE (B&S)	ROT (B&S)
	27110425/0		ROSSO (Tecumseh)	RED (Tecumseh)	ROUGE (Tecumseh)	ROT (Tecumseh)
	27110379/0		VERDE (B&S)	GREEN (B&S)	VERT (B&S)	GRÜN (B&S)
91	27790010/1	1	TAPPO	CAP	BOUCHON	VERSCHLUSS
92	12735598/0	1	VITE	SCREW	VIS	SCHRAUBE
93	12437503/0	1	PIASTRINA	PLATE	PLAQUE	PLATTE
94	14358731/0	1	ETICHETTA	LABEL	ETIQUETTE	KLEBZETTEL
95	12622651/0	1	SPINA	PIN	GOUPILLE	STIFT

EL63

EL63 M

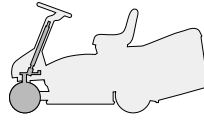

STERZO
STEERING
BARRE DE DIRECTION
LENKGETRIEBE

2005

003.0

1 / 2

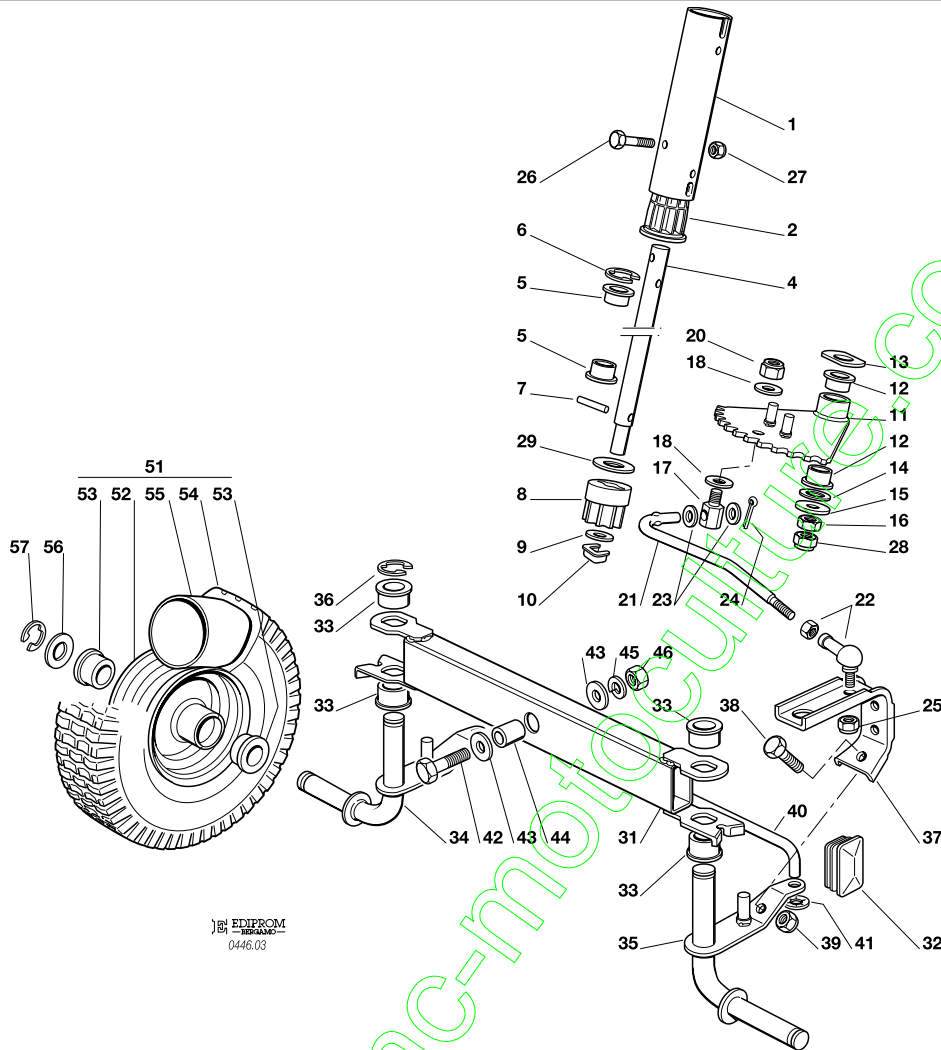

EDIPROM
0446.03

N.	CODE	Q.TY	DESCRIZIONE	DESCRIPTION	DESCRIPTION	BESCHREIBUNG
1	27340305/1	1	PROLUNGA PIANTONE	COLUM EXTENSION	TUBE EXTENSION	VERLÄNGERUNGSSTÜCK
2	27047005/1	1	BUSSOLA	BUSH	DOUILLE	BUCHSE
4	27520052/0	1	PIANTONE STERZO	STEERING COLUMN	TUBE DE DIRECTION	LENKUNGSÄULE
5	27047004/0	2	BUSSOLA	BUSH	DOUILLE	BUCHSE
6	12001010/0	1	ANELLO ELASTICO	SNAP RING	ANNEAU RESSORT	SPRENGRING
7	12622650/0	1	SPINA	PIN	GOUPILLE	STIFT
8	27570050/0	1	PIGNONE	PIGNON	PIGNON	RITZEL
9	12521370/0	1	RONDELLA	WASHER	RONDELLE	SCHEIBE
10	12436030/0	1	PIASTRINA	PLATE	PLAQUETTE	PLATTECHEN
11	84735553/1	1	CORONA STERZO	RING GEAR	COURONNE	ZAHNKRANZ
12	27047004/0	2	BUSSOLA	BUSH	DOUILLE	BUCHSE
13	27670054/0	1	RONDELLA	WASHER	RONDELLE	SCHEIBE
14	22672152/0	1	RONDELLA	WASHER	RONDELLE	SCHEIBE
15	12523065/0	1	RONDELLA	WASHER	RONDELLE	SCHEIBE
16	12293200/0	1	DADO	NUT	ECROU	MUTTER
17	25510056/0	1	PERNO	PIN	PIVOT	BOLZEN
18	25670008/1	2	RONDELLA	WASHER	RONDELLE	SCHEIBE
20	12156602/0	1	DADO	NUT	ECROU	MUTTER
21	27034066/2	1	ASTA	ROD	BARRE	STANGE
22	22746601/0	1	SNODO	JOINT	JOINT	GELENK
23	25670008/1	2	RONDELLA	WASHER	RONDELLE	SCHEIBE
24	12141818/0	1	COPPIGLIA	COTTER PIN	GOUPILLE	SPLIT
25	12155000/0	1	DADO	NUT	ECROU	MUTTER
26	12689515/0	2	VITE	SCREW	VIS	SCHRAUBE
27	12154510/0	2	DADO	NUT	ECROU	MUTTER
28	12155000/0	1	DADO	NUT	ECROU	MUTTER
29	27670054/0	1	RONDELLA	WASHER	RONDELLE	SCHEIBE
31	84034059/0	1	BILANCIERE	EQUALIZER	BALANCIER	KIPPHEBEL
32	18737852/0	2	TAPPO CHIUSURA	CAP	BOUCHON	VERSCHLUSS





N.	CODE	Q.TY	DESCRIZIONE	DESCRIPTION	DESCRIPTION	BESCHREIBUNG
33	27047004/0	4	BRONZINA	BUSH	DOUILLE	BÜCHSE
34	84230405/0	1	FUSELLO DESTRO	RIGHT STUB AXLE	FUSEAU DROITE	RECHTER ACHSSCHENKEL
35	84230407/0	1	FUSELLO SINISTRO	LEFT STUB AXLE	FUSEAU GAUCHE	LINKER ACHSSCHENKEL
36	12000970/0	1	ANELLO ELASTICO	SNAP RING	ANNEAU RESSORT	SPRENGRING
37	27787041/0	1	SUPPORTO	SUPPORT	SUPPORT	HALTER
38	12793102/0	1	VITE	SCREW	VIS	SCHRAUBE
39	12155000/0	1	DADO	NUT	ECROU	MUTTER
40	27840051/0	1	TIRANTE	TIE ROD	TIRANT	SPANNSTANGE
41	12604899/0	2	FISSATORE A CORONA	CROWN FASTENER	FIXATEUR A COURONNE	KRONENSCHNITZ
42	12692695/0	1	VITE	SCREW	VIS	SCHRAUBE
43	12523100/0	2	RONDELLA	WASHER	RONDELLE	SCHNITTSCHEIBE
44	25160016/0	1	DISTANZIALE	SPACER	ENTRETOISE	ENTFERNUNGSSTÜCK
45	12587100/0	1	GROWER	GROWER	GROWER	GROWER
46	12295300/0	1	DADO	NUT	ECROU	MUTTER
51	84680056/0	2	ASS. RUOTA ANTERIORE	FRONT WHEEL	ROUE AVANT	VORDERRAD
52	84044002/0	2	CERCHIO	RIMM	BANDAGE ROUE	VORDERRAD FELGER
53	27045070/0	4	BOCCOLA	BUSH	DOUILLE	BUCHSE
54	27590054/0	2	PNEUMATICO	SHOE	PNEU	REIFEN
55	27590056/0	2	CAMERA D'ARIA	INNER TUBE	CHAMBRE A AIR	REIFENSCHLAUCH
56	12521390/0	2	RONDELLA	WASHER	RONDELLE	SCHNITTSCHEIBE
57	12000970/0	2	ANELLO ELASTICO	SNAP RING	ANNEAU RESSORT	SPRENGRING

contact@emc-motoculture.com

EL63

EL63 M

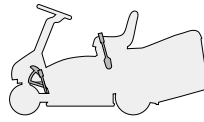

COMANDO FRENO E COMANDO CAMBIO
BRAKE AND GEARBOX CONTROLS
COMMANDE FREIN ET BOITE DE VITESSE
BREMSE UND WECHSEL ANTRIEB

2005

004.0

1 / 1

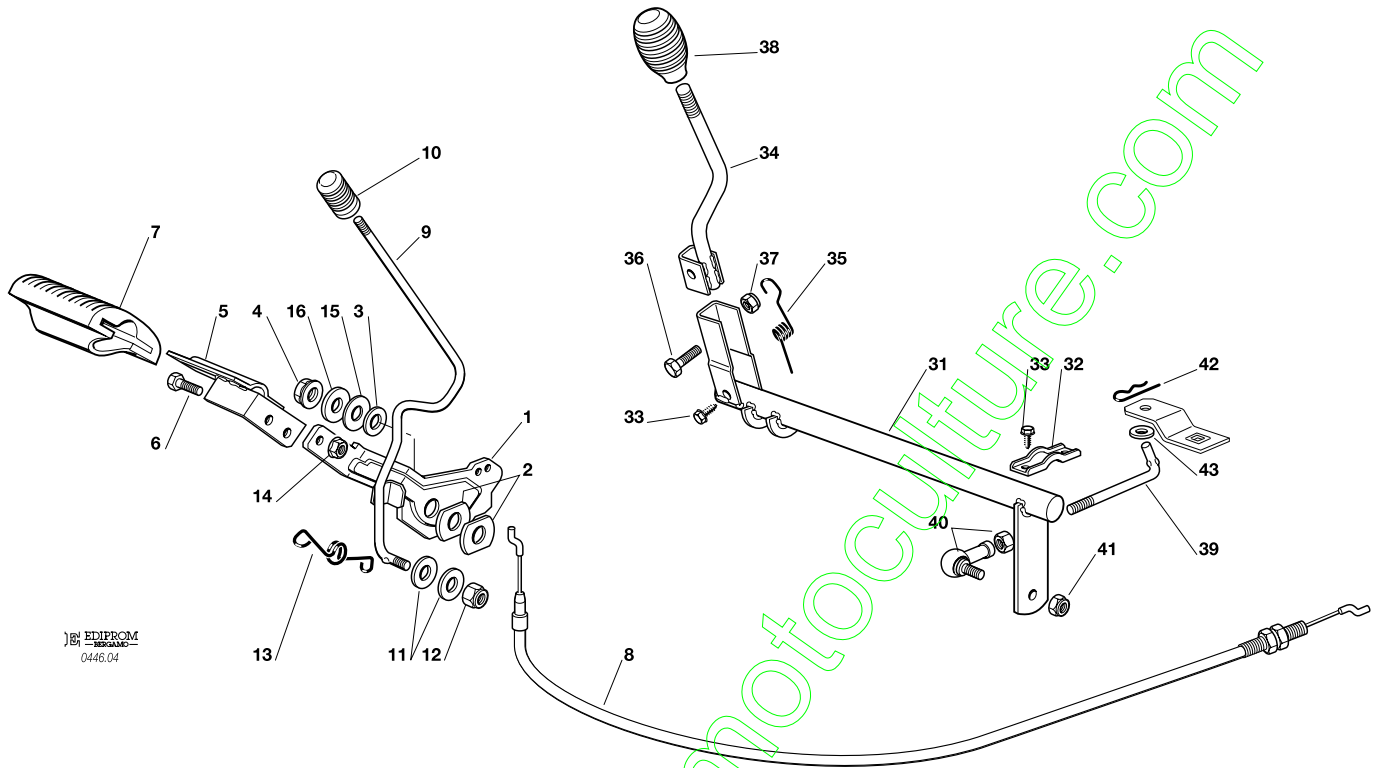

EDIPROM
0446.04

N.	CODE	Q.TY	DESCRIZIONE	DESCRIPTION	DESCRIPTION	BESCHREIBUNG
1	27500051/0	1	PEDALE FRENO	PEDAL	PEDAL	PEDAL
2	27670054/0	2	RONDELLA	WASHER	RONDELLE	SCHEIBE
3	12521350/0	1	RONDELLA	WASHER	RONDELLE	SCHEIBE
4	12154210/0	1	DADO	NUT	ECROU	MUTTER
5	84503005/0	1	PEDALE FRENO SUP.	PEDAL UPPER	PEDAL SUPERIEUR	PEDAL, OBER
6	12791200/0	2	VITE	SCREW	VIS	SCHRAUBE
7	25110269/0	1	COPRISTAFFA	CLAMP COVER	COUVRE ETRIER	BRIDEDECKEL
8	84207105/0	1	FILO	CABLE	FIL	KABEL
9	27034064/1	1	ASTA	ROD	BARRE	STANGE
10	27395050/1	1	MANOPOLINA	KNOB	POIGNEE	KNOPF
11	25670011/0	2	RONDELLA	WASHER	RONDELLE	SCHEIBE
12	12155000/0	1	DADO	NUT	ECROU	MUTTER
13	27430564/0	1	MOLLA	SPRING	RESSORT	FEDER
14	12292102/0	2	DADO	NUT	ECROU	MUTTER
15	27670055/0	1	RONDELLA	WASHER	RONDELLE	SCHEIBE
16	12523060/0	1	RONDELLA	WASHER	RONDELLE	SCHEIBE
31	84001021/0	1	ASSE CAMBIO	AXLE	AXE	ACHSE
32	27546015/1	2	PIASTRINA	PLATE	PLAQUE	PLATTE
33	12729600/0	5	VITE	SCREW	VIS	SCHRAUBE
34	84317071/0	1	LEVA	GEARSHIFT	LEVIER	HEBEL
35	27430570/1	1	MOLLA	SPRING	RESSORT	FEDER
36	12674700/0	1	VITE	SCREW	VIS	SCHRAUBE
37	12154510/0	1	DADO	NUT	ECROU	MUTTER
38	25394510/0	1	MANOPOLA	KNOB	POIGNEE	KNOPF
39	27034063/0	1	ASTA	ROD	BARRE	STANGE
40	22746601/0	1	SNODO	JOINT	JOINT	GELENK
41	12155000/0	1	DADO	NUT	ECROU	MUTTER
42	24487997/0	1	COPPIGLIA	COTTER PIN	GOUPILLE	SPLIT
43	25670011/0	1	RONDELLA	WASHER	RONDELLE	SCHEIBE

EL63

EL63 M

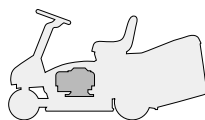

MOTORE
ENGINE
MOTEUR
MOTOR
B&S

2005

005.0

1 / 1

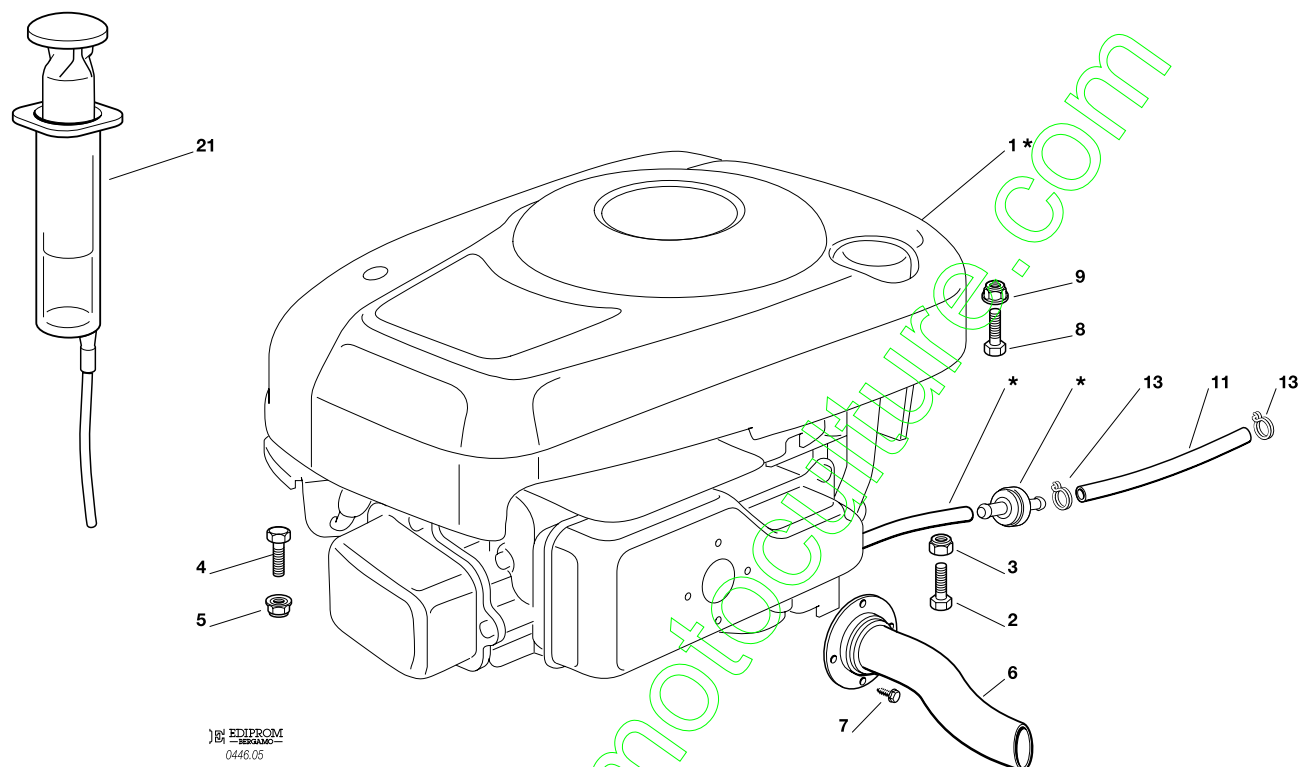

EDIPROM
0446.05

N.	CODE	Q.TY	DESCRIZIONE	DESCRIPTION	DESCRIPTION	BESCHREIBUNG
1*	-	1	MOTORE	ENGINE	MOTEUR	MOTOR
2	12691800/0	1	VITE	SCREW	VIS	SCHRAUBE
3	12155000/0	1	DADO	NUT	ECROU	MUTTER
4	12793701/0	1	VITE	SCREW	VIS	SCHRAUBE
5	12154210/0	1	DADO	NUT	ECROU	MUTTER
6	84869053/0	1	TUBO SCARICO	EXAUSTE TUBE	TUBE DE ECHAPPEMENT	ROHR FÜR APGASUNG
7	12735111/0	4	VITE	SCREW	VIS	SCHRAUBE
8	12691100/0	1	VITE	SCREW	VIS	SCHRAUBE
9	12154210/0	1	DADO	NUT	ECROU	MUTTER
11	38780530/2	1	TUBO CARBURANTE	TUBE	TUBE	ROHR
13	18375051/1	2	FASCETTA	FAIR LED	FIXATION DE CABLE	KABELBEFESTIGUNG
21	18718000/0	1	SIRINGA	SYRINGE	SERINGUE	SPRITZE

PER LA SOSTITUZIONE DELLE PARTI CONTRASSEGNAE CON «*» RIVOLGERSI AL SERVIZIO ASSISTENZA DEL COSTRUTTORE DEL MOTORE.
TO REPLACE THE PARTS MARKED «*» SEEK ASSISTANCE FROM THE ENGINE MANUFACTURER'S AFTER SALES SERVICE.
POUR LE REMPLACEMENT DES PIÈCES MARQUÉES AVEC «*» S'ADRESSER AU SERVICE APRÈS VENTES DU CONSTRUCTEUR DU MOTEUR.
ZUM AUSTAUSCH DER MIT «*» GEKENNZEICHNETEN TEILE, WENDEN SIE SICH AN DEN KUNDENDIENST DES HERSTELLERS DES MOTOR.

EL63

EL63 M

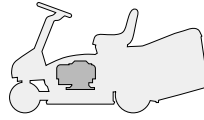

MOTORE
ENGINE
MOTEUR
MOTOR
TECUMSEH

2005

005a.0

1 / 1

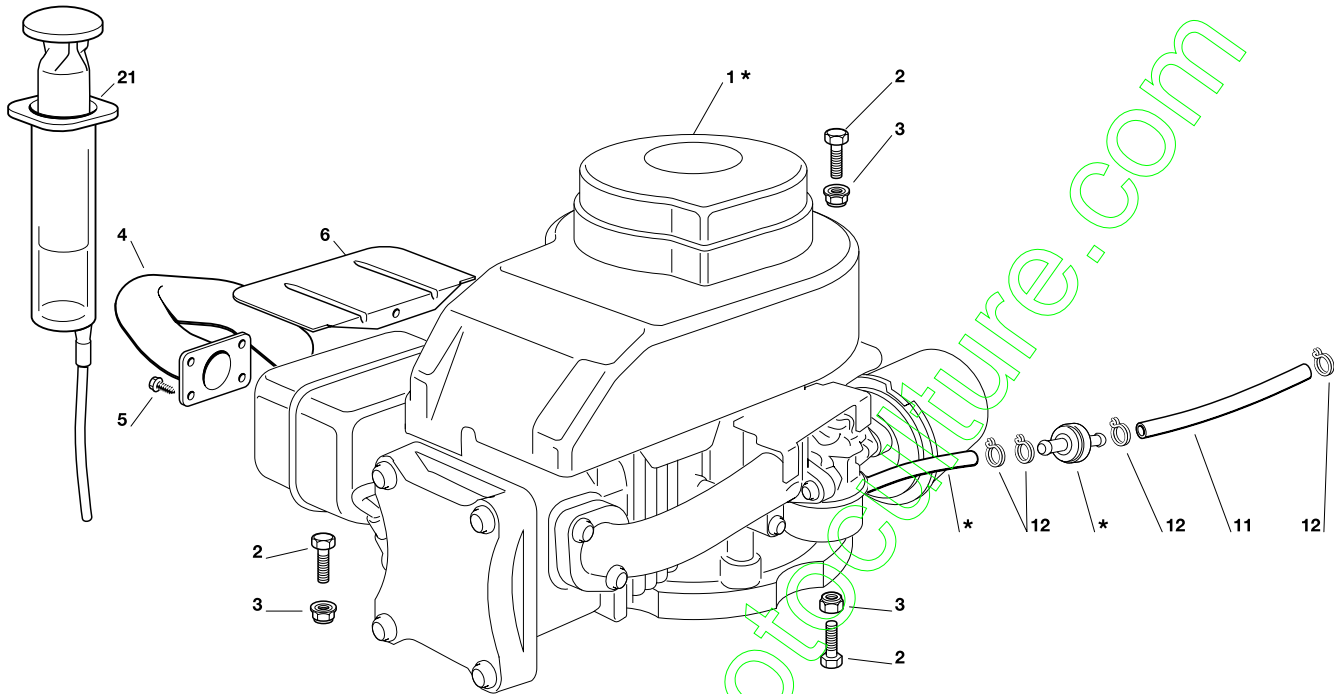

EDIPROM
0446.05a

N.	CODE	Q.TY	DESCRIZIONE	DESCRIPTION	DESCRIPTION	BESCHREIBUNG
1*	-	1	MOTORE	ENGINE	MOTEUR	MOTOR
2	12691400/0	3	VITE	SCREW	VIS	SCHRAUBE
3	12154210/0	3	DADO	NUT	ECROU	MUTTER
4	18738201/0	1	TUBO SCARICO	EXAUSTE TUBE	TUBE DE ECHAPPEMENT	ROHR FÜR APGASUNG
5	12735148/0	4	VITE	SCREW	VIS	SCHRAUBE
6	27600139/0	1	PROTEZIONE SILENZIATORE	MUFFLER PROTECTION	PROTECTION SILENCIEUX	AUSPUFFSCHUTZ
11	25869017/1	1	TUBO CARBURANTE	TUBE	TUBE	ROHR
12	18375051/1	4	FASCETTA	FAIR LED	FIXATION DE CABLE	KABELBEFESTIGUNG
21	18718000/0	1	SIRINGA	SYRINGE	SERINGUE	SPRITZE

PER LA SOSTITUZIONE DELLE PARTI CONTRASSEGNAE CON «*» RIVOLGERSI AL SERVIZIO ASSISTENZA DEL COSTRUTTORE DEL MOTORE.
TO REPLACE THE PARTS MARKED «*» SEEK ASSISTANCE FROM THE ENGINE MANUFACTURER'S AFTER SALES SERVICE.
POUR LE REMPLACEMENT DES PIÈCES MARQUÉES AVEC «*» S'ADRESSER AU SERVICE APRÈS VENTES DU CONSTRUCTEUR DU MOTEUR.
ZUM AUSTAUSCH DER MIT «*» GEKENNZEICHNETEN TEILE, WENDEN SIE SICH AN DEN KUNDENDIENST DES HERSTELLERS DES MOTOR.

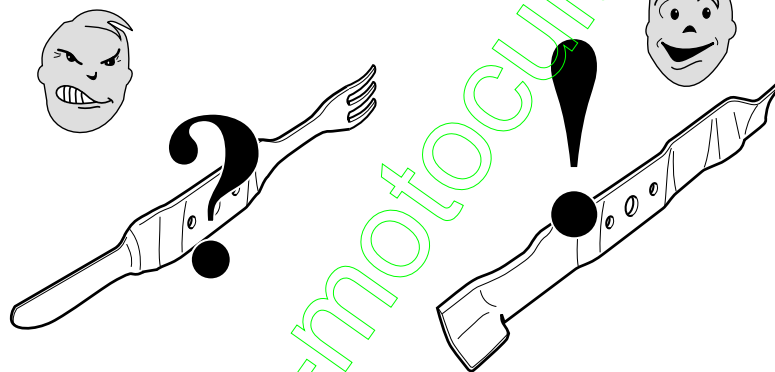

USARE SOLO RICAMBI ORIGINALI!
USE ONLY GENUINE SPARE PARTS!
UTILISER DES PIÈCES DE RECHANGE D'ORIGINE!
NUR ORIGINALERSATZTEILE VERWENDEN!

EL63

EL63 M

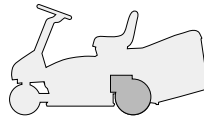

TRASMISSIONE
TRANSMISSION
TRANSMISSION
GETRIEBE

2005

006.0

1 / 2

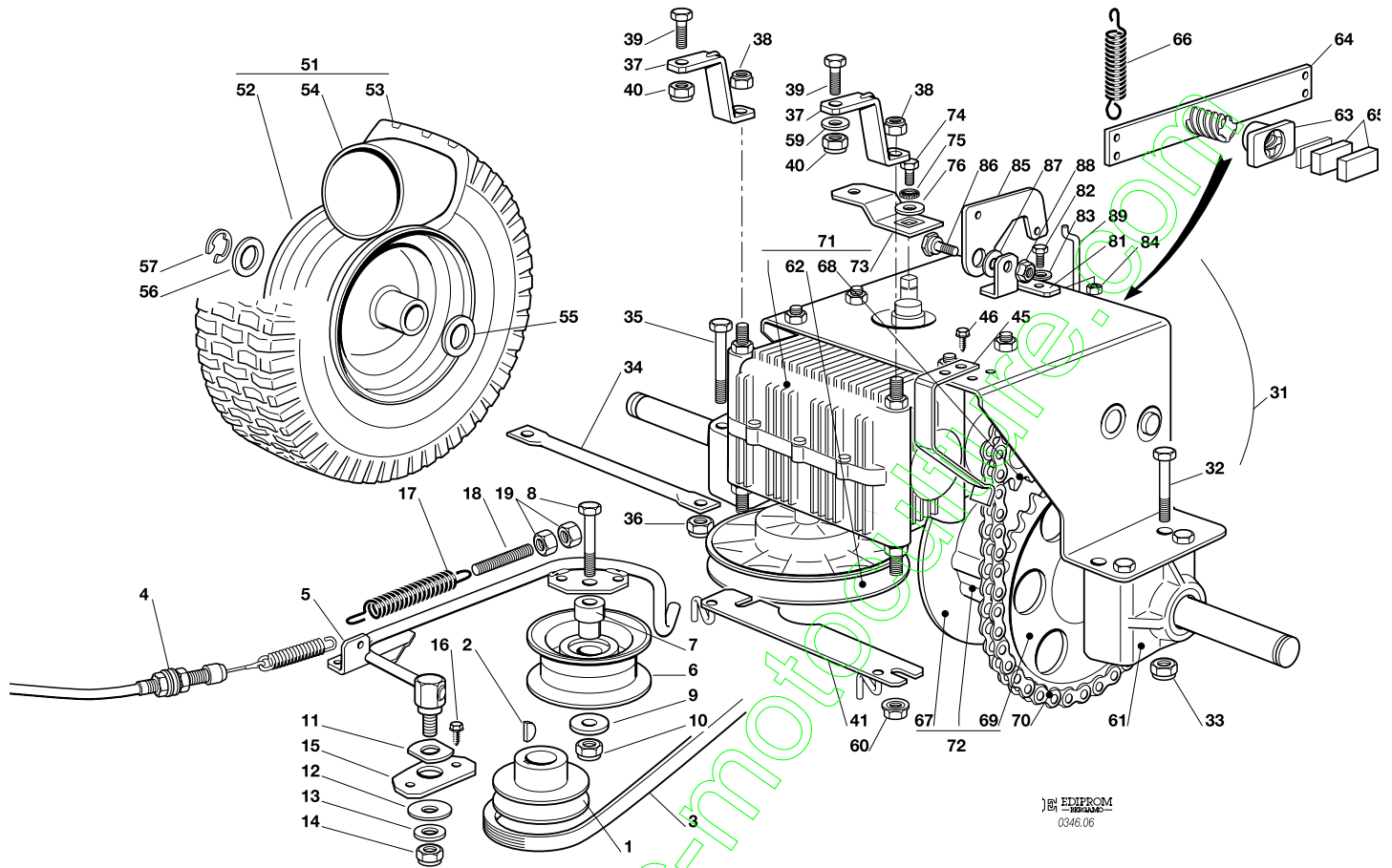

EDIPROM
0346.06

N.	CODE	Q.TY	DESCRIZIONE	DESCRIPTION	DESCRIPTION	BESCHREIBUNG
1	27604006/2	1	PULEGGIA	PULLEY	POULIE	RIEMENSCHLEIBE
2	12139100/0	1	LINGUETTA	KEY	CLAVETTE	KEIL
3	35061406/0	1	CINGHIA	BELT	COURROIE	RIEMEN
4	84207103/2	1	FILO	CABLE	FIL	KABEL
5	84317077/0	1	LEVA	LEVER	LEVIER	HEBEL
6	27604007/0	1	PULEGGIA	PULLEY	POULIE	RIEMENSCHLEIBE
7	27047007/0	1	BUSSOLA	BUSH	DOUILLE	BUCHSE
8	12691200/0	1	VITE	SCREW	VIS	SCHRAUBE
9	12523060/0	1	ROSETTA	WASHER	RONDELLE	SCHEIBE
10	12155000/0	1	DADO	NUT	ECROU	MUTTER
11	27670054/0	1	RONDELLA	WASHER	RONDELLE	SCHEIBE
12	12523070/0	1	RONDELLA	WASHER	RONDELLE	SCHEIBE
13	25670011/0	1	RONDELLA	WASHER	RONDELLE	SCHEIBE
14	12155000/0	1	DADO	NUT	ECROU	MUTTER
15	27546029/0	1	PIASTRINA	PLATE	PLAQUE	PLATTE
16	12735121/0	2	VITE	SCREW	VIS	SCHRAUBE
17	25430219/0	1	MOLLA	SPRING	RESSORT	FEDER
18	25840005/0	1	TIRANTE	TIE ROD	TIRANT	SPANNSTANGE
19	12293200/0	2	DADO	NUT	ECROU	MUTTER
31	18400970/1	1	GRUPPO TRASMISSIONE	TRANSMISSION UNIT	GRUPE TRANSMISSION	ANTRIEBSGRUPPE
32	12692050/0	3	VITE	SCREW	VIS	SCHRAUBE
33	12154210/0	4	DADO	NUT	ECROU	MUTTER
34	27840053/0	1	RINFORZO	STIFFENING	REINFORCEMENT	VERSTAERKUNG
35	25943001/0	1	VITE	SCREW	VIS	SCHRAUBE
36	12155000/0	2	DADO	NUT	ECROU	MUTTER
37	27650119/0	2	RINFORZO	STIFFENING	REINFORCEMENT	VERSTAERKUNG
38	12155000/0	2	DADO	NUT	ECROU	MUTTER
39	12793701/0	1	VITE	SCREW	VIS	SCHRAUBE
40	12293201/0	1	DADO	NUT	ECROU	MUTTER





N.	CODE	Q.TY	DESCRIZIONE	DESCRIPTION	DESCRIPTION	BESCHREIBUNG
41	84250051/0	1	GUIDACINGHIA	BELT GUIDE	GUIDE DE CURROIRE	RIEMENFUHRUN
45	84394830/0	1	MOLLA	SPRING	RESSORT	FEDER
46	12735104/0	2	VITE	SCREW	VIS	SCHRAUBE
51	84680057/0	2	RUOTA POSTERIORE	REAR WHEEL	ROUE ARRIERE	HINTERRAD
52	84044001/0	2	CERCHIO	RIMM	BANDAGE ROUE	HINTRERRAD FELGER
53	27590055/0	2	PNEUMATICO	SHOE	PNEU	REIFEN
54	27590057/0	2	CAMERA D'ARIA	INNER TUBE	CHAMBRE A AIR	REIFENSCHLAUCH
55	12521410/0	2	ROSETTA	WASHER	RONDELLE	SCHEIBE
56	25670005/1	2	RONDELLA	WASHER	RONDELLE	SCHEIBE
57	12001010/0	2	ANELLO	RING	ANNEAU	RING
59	12523070/0	1	RONDELLA	WASHER	RONDELLE	SCHEIBE
60	12293201/0	2	DADO	NUT	ECROU	MUTTER
61	19700056/0	3	BUSSOLA	BUSH	DOUILLE	BUCHSE
62	19700050/0	1	PULEGGIA	PULLEY	POULIE	RIEMENSCHLEIBE
63	19700051/0	1	MADREVITE	NUT SCREW	ECROU	MUTTER
64	19700053/0	1	LEVA CON VITE	LEVER WITH SCREW	LEVIER AVEC VIS	HEBEL MIT SCHRAUBE
65	19700052/0	2	PASTIGLIA	PAD	PLAQUETTE	BREMSBELÄGE
66	19700048/0	1	MOLLA	SPRING	RESSORT	FEDER
67	19700054/0	1	DISCO FRENO	BRAKE DISC	DISQUE FREIN	BREMSSCHLEIBE
68	19700049/0	1	PIGNONE	PINION	PIGNON	RITZEL
69	19700055/0	1	RUOTA DENTATA	SPROCKET	COUJONNE	ZAHNKETTENRAD
70	19700047/0	1	CATENA	CHAIN	CHAÎNE	KETTE
71	18400972/0	1	CAMBIO (con 62, 68, 73)	GEAR BOX (with 62, 68, 73)	BOÎTE DE VITESSE (avec 62, 68, 73)	GETRIEBE (mit 62, 68, 73)
72	18400971/0	1	DIFFERENZIALE (con 67, 69)	DIFFERENTIAL (with 67, 69)	DIFFERENTIEL (avec 67, 69)	DIFFERENTIAL (mit 67, 69)
73	27315105/0	1	LEVA	GEARSHIFT	LEVIER	HEBEL
74	12791011/0	1	VITE	SCREW	VIS	SCHRAUBE
75	12540040/0	1	ROSETTA	WASHER	RONDELLE	SCHEIBE
76	22680009/0	1	RONDELLA	WASHER	RONDELLE	SCHEIBE
81	27753079/0	1	SQUADRETTA	ANGLE BRACKET	EQUERRE	WINKEL
82	12791200/0	2	VITE	SCREW	VIS	SCHRAUBE
83	12523040/0	2	RONDELLA	WASHER	RONDELLE	SCHEIBE
84	12292102/0	2	DADO	NUT	ECROU	MUTTER
85	27772145/0	1	STAFFA	CLAMP	ETRIER	BRIDE
86	22524970/2	1	PERNO	PIN	PIVOT	BOLZEN
87	25670011/0	1	RONDELLA	WASHER	RONDELLE	SCHEIBE
88	12154210/0	1	DADO	NUT	ECROU	MUTTER
89	27034076/0	1	ASTA	ROD	TIGE	STANGE

contact@emc-motoculture.com

EL63

EL63 M

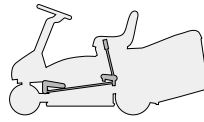

SOLLEVAMENTO PIATTO DI TAGLIO
CUTTING PLATE LIFTING
SOULEVEMENT PLATEAU DE COUPE
SCHNEIDWERKZEUG AUFHEBESATZ

2005

007.0

1 / 2

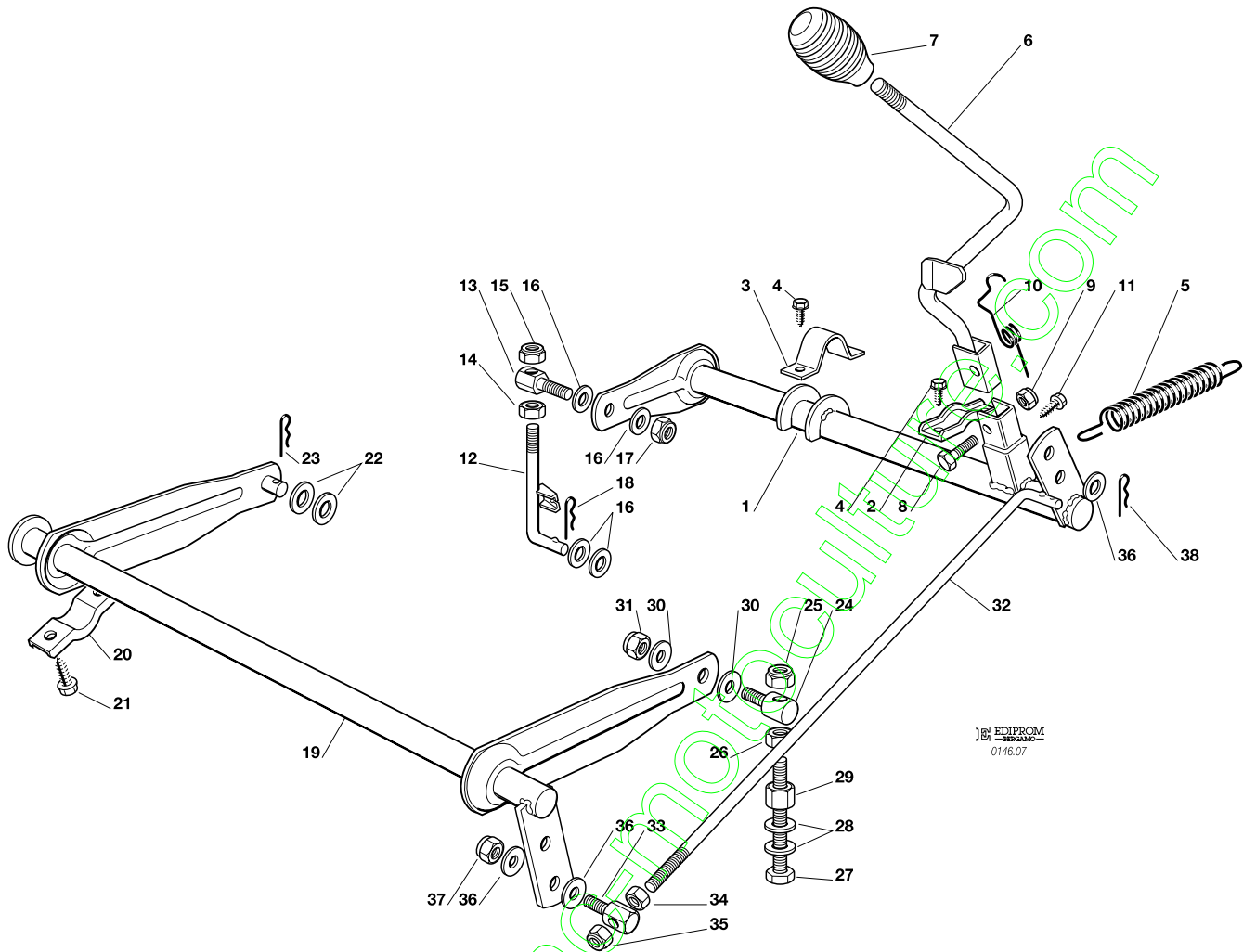

EDIPROM
0146.07

N.	CODE	Q.TY	DESCRIZIONE	DESCRIPTION	DESCRIPTION	BESCHREIBUNG
1	84001017/0	1	ASSE SOLLEVAMENTO POST.	AXLE	AXE	ACHSE
2	27546015/1	1	PIASTRINA	PLATE	PLAQUE	PLATTE
3	25547037/1	1	PIASTRINA	PLATE	PLAQUE	PLATTE
4	12729600/0	4	VITE	SCREW	VIS	SCHRAUBE
5	27430568/0	1	MOLLA	SPRING	RESSORT	FEDER
6	84317075/0	1	LEVA	GEARSHIFT	LEVIER	HEBEL
7	25394510/0	1	MANOPOLA	KNOB	POIGNEE	KNOPF
8	12674700/0	1	VITE	SCREW	VIS	SCHRAUBE
9	12154510/0	1	DADO	NUT	ECROU	MUTTER
10	27430574/0	1	MOLLA	SPRING	RESSORT	FEDER
11	12729600/0	1	VITE	SCREW	VIS	SCHRAUBE
12	84002073/0	1	ASTA POSTERIORE	ROD	BARRE	STANGE
13	25510056/0	1	PERNO	PIN	PIVOT	BOLZEN
14	12295200/0	1	DADO	NUT	ECROU	MUTTER
15	12156602/0	1	DADO	NUT	ECROU	MUTTER
16	25670008/1	4	RONDELLA	WASHER	RONDELLE	SCHEIBE
17	12156602/0	1	DADO	NUT	ECROU	MUTTER
18	24487997/0	1	COPPIGLIA	COTTER PIN	GOUPILLE	SPLIT
19	84001019/0	1	ASSE SOLLEVAMENTO ANT.	AXLE	AXE	ACHSE
20	27546015/1	2	PIASTRINA	PLATE	PLAQUE	PLATTE
21	12731350/0	4	VITE	SCREW	VIS	SCHRAUBE
22	25670008/1	2	RONDELLA	WASHER	RONDELLE	SCHEIBE
23	24487997/0	1	COPPIGLIA	COTTER PIN	GOUPILLE	SPLIT
24	25510007/1	1	PERNO	PIN	PIVOT	BOLZEN
25	12156602/0	1	DADO	NUT	ECROU	MUTTER
26	12295200/0	1	DADO	NUT	ECROU	MUTTER
27	12794970/0	1	VITE	SCREW	VIS	SCHRAUBE
28	12521360/0	2	RONDELLA	WASHER	RONDELLE	SCHEIBE
29	12154250/0	1	DADO	NUT	ECROU	MUTTER
30	25670008/1	2	RONDELLA	WASHER	RONDELLE	SCHEIBE
31	12156602/0	1	DADO	NUT	ECROU	MUTTER





N.	CODE	Q.TY	DESCRIZIONE	DESCRIPTION	DESCRIPTION	BESCHREIBUNG
32	27034065/0	1	ASTA	ROD	BARRE	STANGE
33	25510040/1	1	PERNO	PIN	PIVOT	BOLZEN
34	12293200/0	1	DADO	NUT	ECROU	MUTTER
35	12155000/0	1	DADO	NUT	ECROU	MUTTER
36	25670011/0	3	RONDELLA	WASHER	RONDELLE	SCHEIBE
37	12155000/0	1	DADO	NUT	ECROU	MUTTER
38	24487997/0	1	COPPIGLIA	COTTER PIN	GOUPILLE	SPLIT

contact@enc-motoculture.com

EL63

EL63 M

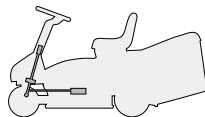

PIATTO DI TAGLIO (1)
CUTTING PLATE (1)
PLATEAU DE COUPE (1)
SCHNEIDWERKZEUG (1)
B&S

2005

008.0

1 / 1

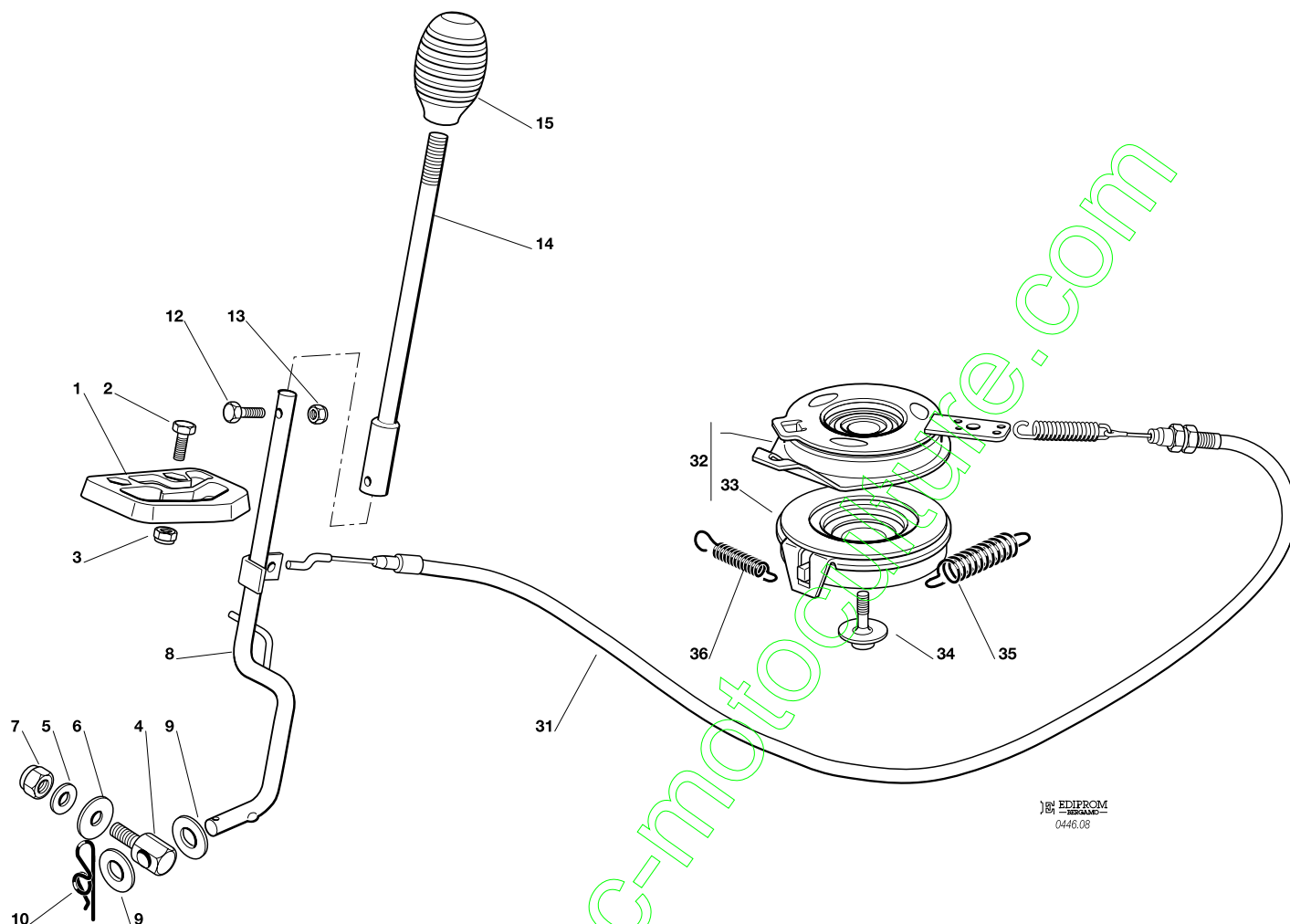

EDIPROM
0446.08

N.	CODE	Q.TY	DESCRIZIONE	DESCRIPTION	DESCRIPTION	BESCHREIBUNG
1	27487001/0	1	PATTINO	SHOE	BLOC DE GLISSEMENT	GLEITBLOCK
2	12791200/0	2	VITE	SCREW	VIS	SCHRAUBE
3	12154510/0	2	DADO	NUT	ECROU	MUTTER
4	27510107/0	1	PERNO	PIN	PIVOT	BOLZEN
5	25670011/0	1	RONDELLA	WASHER	RONDELLE	SCHEIBE
6	22672152/0	1	RONDELLA	WASHER	RONDELLE	SCHEIBE
7	12155000/0	1	DADO	NUT	ECROU	MUTTER
8	84317073/1	1	LEVA	LEVER	LEVIER	HEBEL
9	21660100/0	2	RALLA	THRUST WASHER	BUTEE	SCHEIBE
10	24487998/0	1	COPPIGLIA	COTTER PIN	GOUPILLE	SPLIT
12	12789020/0	1	VITE	SCREW	VIS	SCHRAUBE
13	12154330/0	1	DADO	NUT	ECROU	MUTTER
14	84317079/0	1	LEVA	GEARSHIFT	LEVIER	HEBEL
15	25394510/0	1	MANOPOLA	KNOB	POIGNEE	KNOPF
31	84207104/1	1	FILO	CABLE	FIL	KABEL
32	18399065/1	1	ASS. FRIZIONE MECCANICA	MECHANICAL CLUTCH ASS.Y	ENS. EMBRAYAGE MECAN.	MECHANISCHE KUPPLUNG
33	18399066/1	1	PORTE INFERIORE FRIZIONE	CLUTCH, LOWER PART	PARTIE INFER. EMBRAYAGE	KUPPLUNG, UNTERSEITE
34	12735460/0	1	VITE	SCREW	VIS	SCHRAUBE
35	27430579/0	1	MOLLA	SPRING	RESSORT	FEDER
36	22450110/0	1	MOLLA	SPRING	RESSORT	FEDER

EL63

EL63 M

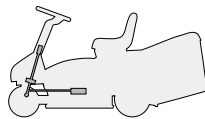

PIATTO DI TAGLIO (1)
CUTTING PLATE (1)
PLATEAU DE COUPE (1)
SCHNEIDWERKZEUG (1)
TECUMSEH

2005

008a.0

1 / 1

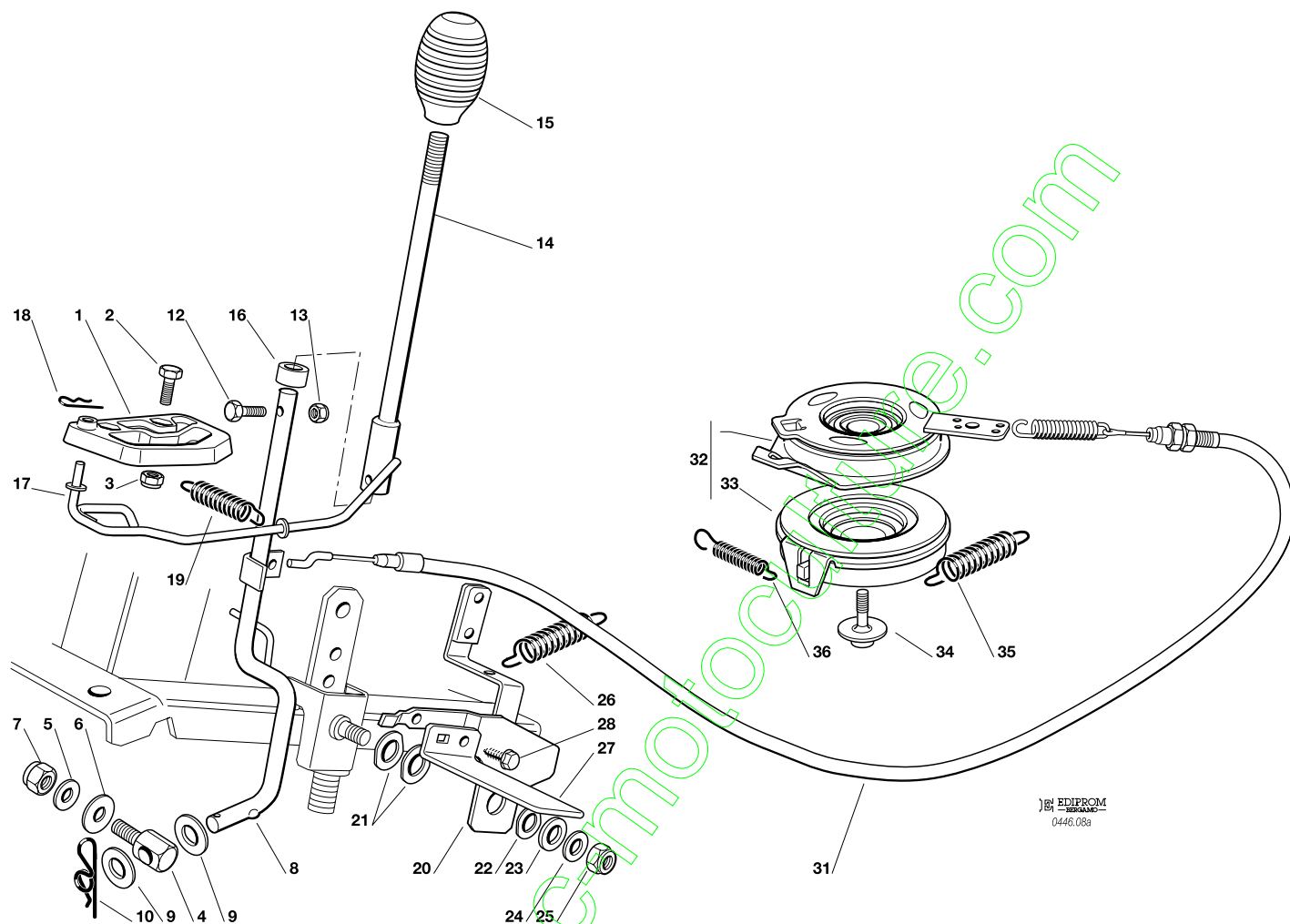

EDIPROM
SERVIZIO
0446.08a

N.	CODE	Q.TY	DESCRIZIONE	DESCRIPTION	DESCRIPTION	BESCHREIBUNG
1	27487003/0	1	PATTINO	SHOE	BLOC DE GLISSEMENT	GLEITBLOCK
2	12791200/0	2	VITE	SCREW	VIS	SCHRAUBE
3	12154510/0	2	DADO	NUT	ECROU	MUTTER
4	27510107/0	1	PERNO	PIN	PIVOT	BOLZEN
5	25670011/0	1	RONDELLA	WASHER	RONDELLE	SCHEIBE
6	22672152/0	1	RONDELLA	WASHER	RONDELLE	SCHEIBE
7	12155000/0	1	DADO	NUT	ECROU	MUTTER
8	84317073/0	1	LEVA	LEVER	LEVIER	HEBEL
9	21660100/0	2	RALLA	THRUST WASHER	BUTEE	SCHEIBE
10	24487998/0	1	COPPIGLIA	COTTER PIN	GOUPILLE	SPLIT
12	12789020/0	1	VITE	SCREW	VIS	SCHRAUBE
13	12154330/0	1	DADO	NUT	ECROU	MUTTER
14	84317079/0	1	LEVA	GEARSHIFT	LEVIER	HEBEL
15	25394510/0	1	MANOPOLA	KNOB	POIGNEE	KNOPF
16	27045071/0	1	BOCCOLA	BUSH	DOUILLE	BUCHSE
17	27034082/0	1	ASTA	ROD	BARRE	STANGE
18	24487995/0	1	COPPIGLIA	COTTER PIN	GOUPILLE	SPLIT
19	27430585/0	1	MOLLA	SPRING	RESSORT	FEDER
20	84503009/0	1	LEVA PEDALE	LEVER	LEVIER	HEBEL
21	27670054/0	2	RONDELLA	WASHER	RONDELLE	SCHEIBE
22	27670056/0	1	RONDELLA	WASHER	RONDELLE	SCHEIBE
23	12523060/0	1	RONDELLA	WASHER	RONDELLE	SCHEIBE
24	12521350/0	1	RONDELLA	WASHER	RONDELLE	SCHEIBE
25	12154210/0	1	DADO	NUT	ECROU	MUTTER
26	27430585/0	1	MOLLA	SPRING	RESSORT	FEDER
27	27500057/0	1	PEDALE	PEDAL	PEDAL	PEDAL
28	27943051/0	1	VITE	SCREW	VIS	SCHRAUBE
31	84207104/1	1	FILO	CABLE	FIL	KABEL
32	18399065/1	1	ASS. FRIZIONE MECCANICA	MECHANICAL CLUTCH ASS.Y	ENS. EMBRAYAGE MECAN.	MECHANISCHE KUPPLUNG
33	18399066/1	1	PARTE INFERIORE FRIZIONE	CLUTCH, LOWER PART	PARTIE INFER. EMBRAYAGE	KUPPLUNG, UNTERSEITE
34	12735460/0	1	VITE	SCREW	VIS	SCHRAUBE
35	27430579/0	1	MOLLA	SPRING	RESSORT	FEDER
36	22450110/0	1	MOLLA	SPRING	RESSORT	FEDER

EL63

EL63 M

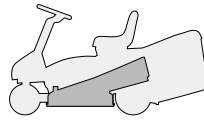

PIATTO DI TAGLIO (2)
CUTTING PLATE (2)
PLATEAU DE COUPE (2)
SCHNEIDWERKZEUG (2)

2005

009.0

1 / 2

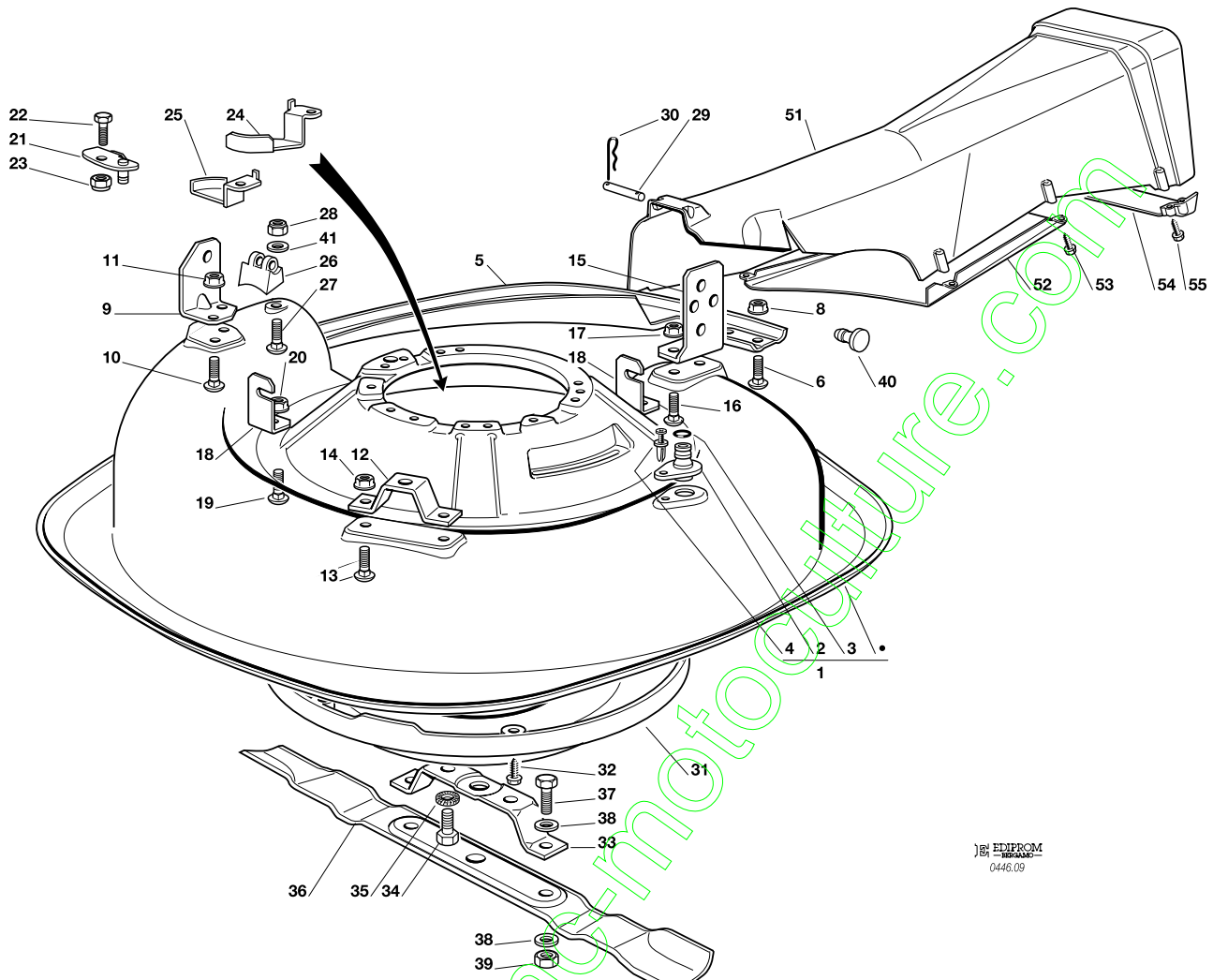

EDIPROM
0446.09

N.	CODE	Q.TY	DESCRIZIONE	DESCRIPTION	DESCRIPTION	BESCHREIBUNG
1	84564095/0	1	PIATTO DI TAGLIO	CUTTING PLATE	PLATEAU DE COUPE	SCHNEIDWERKZEUG
2	25033060/0	1	ATTACCO ACQUA	WATER HOSE CONNECTION	RACCORD TUYAU D'EAU	WASSERANSCHLUSS
3	19035000/0	1	ANELLO OR	O RING	O RING	O RING
4	12500030/0	1	RIVETTO	RIVET	RIVET	NIET
5	84650103/0	1	RINFORZO	STIFFENING	RENFORCEMENT	VERSTAERKUNG
6	12815200/0	4	VITE	SCREW	VIS	SCHRAUBE
8	12292102/0	4	DADO	NUT	ECROU	MUTTER
9	27772119/0	1	STAFFA	CLAMP	ETRIER	BRIDE
10	12818690/0	2	VITE	SCREW	VIS	SCHRAUBE
11	12293201/0	2	DADO	NUT	ECROU	MUTTER
12	27772133/0	1	STAFFA	CLAMP	ETRIER	BRIDE
13	12818690/0	2	VITE	SCREW	VIS	SCHRAUBE
14	12293201/0	2	DADO	NUT	ECROU	MUTTER
15	27772127/1	1	STAFFA	CLAMP	ETRIER	BRIDE
16	12818690/0	2	VITE	SCREW	VIS	SCHRAUBE
17	12293201/0	2	DADO	NUT	ECROU	MUTTER
18	27753071/0	2	SQUADRETTA	ANGLE BRACKET	EQUERRE	WINKEL
19	12818690/0	2	VITE	SCREW	VIS	SCHRAUBE
20	12293201/0	2	DADO	NUT	ECROU	MUTTER
21	84545063/0	1	PIASTRINA	PLATE	PLAQUE	PLATTE
22	12792611/0	1	VITE	SCREW	VIS	SCHRAUBE
23	12155000/0	1	DADO	NUT	ECROU	MUTTER
24	27546041/0	1	PIASTRINA	PLATE	PLAQUE	PLATTE
25	27546043/0	1	PIASTRINA	PLATE	PLAQUE	PLATTE
26	27230200/2	1	GANCIO	HOOK	ACCROCHAGE	HAKEN
27	12815210/0	1	VITE	SCREW	VIS	SCHRAUBE
28	12154510/0	1	DADO	NUT	ECROU	MUTTER
29	27510097/1	1	PERNO	PIN	PIVOT	BOLZEN
30	24487997/0	2	COPPIGLIA	COTTER PIN	GOUPILLE	SPLIT
31	27600122/0	1	PROTEZIONE	GUARD	PROTECTION	SCHUTZ
32	12728530/0	5	VITE	SCREW	VIS	SCHRAUBE





N.	CODE	Q.TY	DESCRIZIONE	DESCRIPTION	DESCRIPTION	BESCHREIBUNG
33	27787045/1	1	SUPPORTO COLTELLO	BRACKET	SUPPORT	HALTER
34	12794110/0	2	VITE	SCREW	VIS	SCHRAUBE
35	12540070/0	2	ROSETTA	WASHER	RONDELLE	SCHEIBE
36	84109504/0	1	COLTELLO	BLADE	LAME	MESSER
37	12793102/0	2	VITE	SCREW	VIS	SCHRAUBE
38	12523060/0	4	RONDELLA	WASHER	RONDELLE	SCHEIBE
39	12155010/0	2	DADO	NUT	ECROU	MUTTER
40	27275000/0	1	GOMMINO	GROMMET	CAOUTCHOUC	GUMMI
41	12521330/0	1	RONDELLA	WASHER	RONDELLE	SCHEIBE
51	27107502/0	1	CONVOGLIATORE	CONVEYOR	CONVOYEUR	BLECHSATZ
52	27140053/0	1	DEFLETTORE	DEFLECTOR	DEFLECTEUR	ABWEISER
53	12735402/0	5	VITE	SCREW	VIS	SCHRAUBE
54	27650120/0	1	RINFORZO	STIFFENING	RENFORCEMENT	VERSTAERKUNG
55	12735410/0	2	VITE	SCREW	VIS	SCHRAUBE

contact@enc-motoculture.com

EL63

EL63 M

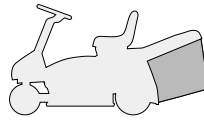

SACCO
GRASSCATCHER
BAC
AUFFANGSACK

2005

010.0

1 / 1

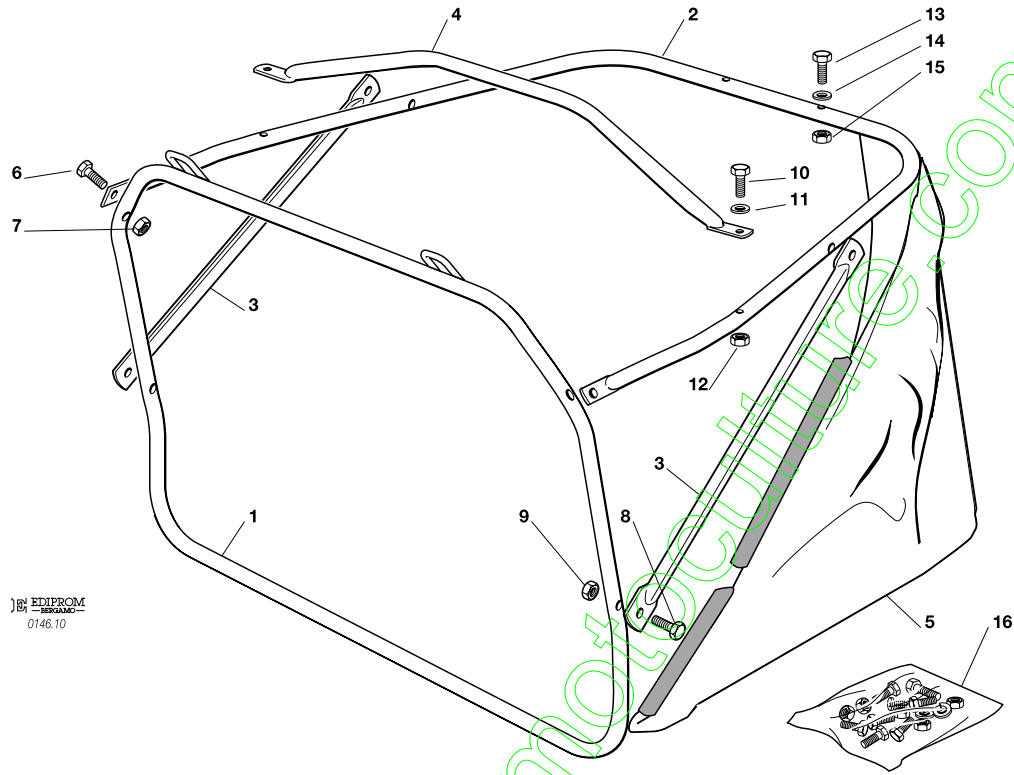

EDIPROM
0146.10

N.	CODE	Q.TY	DESCRIZIONE	DESCRIPTION	DESCRIPTION	BESCHREIBUNG
1	84801121/0	1	TELAIO ANTERIORE	FRONT FRAME	CHASSIS ANTERIEUR	VORDERRAHMEN
2	84801119/0	1	TELAIO SUPERIORE	UPPER FRAME	CHASSIS SUPERIEUR	OBERERRAHMEN
3	27650117/0	2	RINFORZO	STIFFENING	RENFORCEMENT	VERSTAERKUNG
4	84394051/0	1	MANIGLIA	HANDLE	POIGNEE	GRIFF
5	84106055/0	1	CONFEZIONE SACCO	GRASSCATCHER	BAC	SACK
6	12789020/0	2	VITE	SCREW	VIS	SCHRAUBE
7	12154330/0	2	DADO	NUT	ECROU	MUTTER
8	12789020/0	4	VITE	SCREW	VIS	SCHRAUBE
9	12154330/0	4	DADO	NUT	ECROU	MUTTER
10	12789210/0	2	VITE	SCREW	VIS	SCHRAUBE
11	12521331/0	2	ROSETTA	WASHER	RONDELLE	SCHEIBE
12	12154330/0	2	DADO	NUT	ECROU	MUTTER
13	12674530/0	2	VITE	SCREW	VIS	SCHRAUBE
14	12521331/0	2	ROSETTA	WASHER	RONDELLE	SCHEIBE
15	12154330/0	2	DADO	NUT	ECROU	MUTTER
16	84180186/0	1	DOTAZIONE VITERIA (6÷15)	SCREWS OUTFIT (6÷15)	ENSEMBLE DES VIS (6÷15)	SCHRAUBENAUSRÜSTUNG (6÷15)

EL63

EL63 M

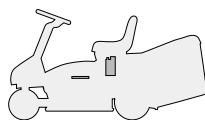

PARTI ELETTRICHE (Avviam. elettrico)
ELECTRICAL PARTS (Electric start)
PARTIES ELECTRIQUES (Dém. électrique)
ELETRISCHETEILE (Elektrische Anlassen)

2005

011.0

1 / 1

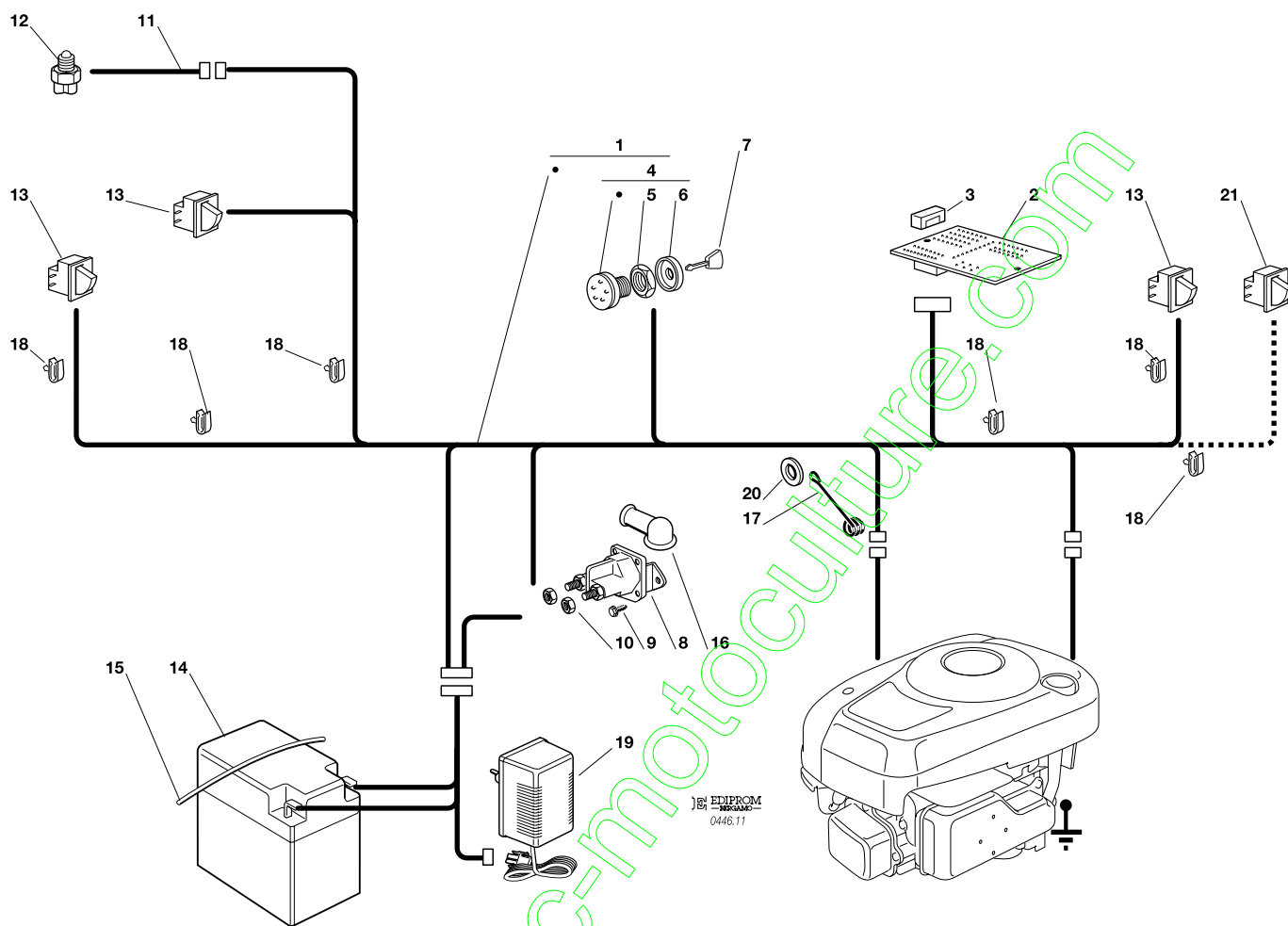

N.	CODE	Q.TY	DESCRIZIONE	DESCRIPTION	DESCRIPTION	BESCHREIBUNG
1	84040123/0	1	CABLAGGIO (B&S)	CABLES (B&S)	CABLAGES (B&S)	KABELSATZ (B&S)
	84040125/0	1	CABLAGGIO (Tecumseh)	CABLES (Tecumseh)	CABLAGES (Tecumseh)	KABELSATZ (Tecumseh)
2	27722354/0	1	SCHEDA ELETTRONICA	ELECTRONIC CARD	CARTE ELECTRONIQUE	ELEKTRONISCHE KARTE
3	33340033/0	1	FUSIBILE	FUSE	FUSIBLE	SICHERUNG
4	18450065/1	1	INTERRUTTORE AVVIAMENTO	STARTING SWITCH	INTERRUPTEUR DEMARRAGE	SCHALTER
5	18400861/0	1	GHIERA	SCREWED RING	EMBOUT	NUTMUTTER
6	18565351/0	1	PROTEZIONE GHIERA	SCREWED RING PROTECTION	PROTECTION EMBOUT	NUTMUTTER SCHUTZ
7	18210016/0	1	CHIAVE AVVIAMENTO	STARTING KEY	CLEF A DEMARRAGE	SCHLÜSSEL FÜR START
8	18736111/0	1	RELÈ AVVIAMENTO	STARTER RELAY	RELAIS D'ALLUMAGE	ANLASSRELAIS
9	12735110/0	2	VITE	SCREW	VIS	SCHRAUBE
10	12360352/0	2	DADO	NUT	ECROU	MUTTER
11	27065060/0	1	CAVO	CABLE	CABLES	KABEL
12	19700046/0	1	INTERRUTTORE CAMBIO	GEARBOX SWITCH	INT. BOÎTE DE VITESSE	ANTRIEB SCHALTER
13	19410606/0	3	MICRO INTERRUTTORE	MICROSWITCH	MICROINTERRUPTEUR	MIKROSCHALTER
14	18120004/0	1	BATTERIA	BATTERY	BATTERIE	BATTERIE
15	27430572/0	1	MOLLA	SPRING	RESSORT	FEDER
16	18564861/1	1	CAPPUCCIO	PROTECTION	CAPUCHON	STECKER
17	25430239/1	1	MOLLA	SPRING	RESSORT	FEDER
18	33320506/0	5	FERMACAVO	FAIRLEAD	FIXATION CABLE	KABELBEFESTIGUNG
19	82180051/0	1	CARICA BATTERIE	BATTERY CHARGER	CHARGEUR BATTERIES	BATTERIELADEGERÄT
19	82180053/0	1	CARICA BATTERIE (UK)	BATTERY CHARGER (UK)	CHARGEUR BATTERIES (UK)	BATTERIELADEGERÄT (UK)
20	12523040/0	1	ROSETTA	WASHER	RONDELLE	SCHIBE
21	19410612/0	1	MICRO INTERRUTTORE (B&S)	MICROSWITCH (B&S)	MICROINTERRUPTEUR (B&S)	MIKROSCHALTER (B&S)

EL63

EL63 M

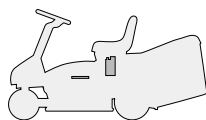

PARTI ELETTRICHE (Avviam. manuale)
 ELECTRICAL PARTS (Manual start)
 PARTIES ELECTRIQUES (Dém. manuelle)
 ELETRISCHETEILE (Anlassen von Hand)

2005

011a.0

1 / 1

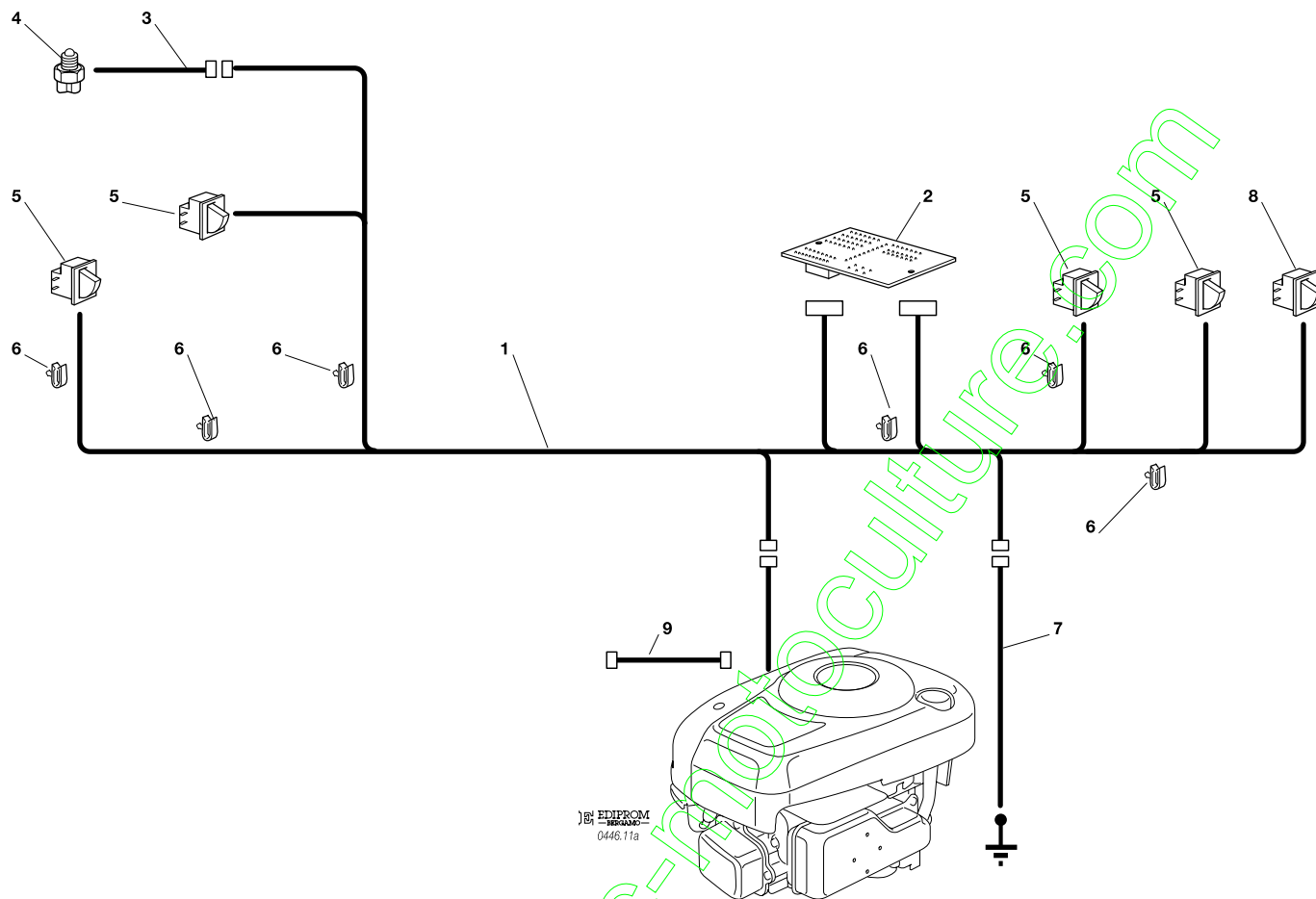

N.	CODE	Q.TY	DESCRIZIONE	DESCRIPTION	DESCRIPTION	BESCHREIBUNG
1	84040122/0	1	CABLAGGIO	CABLES	CABLAGES	KABELSATZ
2	27722356/0	1	SCHEDA ELETTRONICA (B&S)	ELECTRONIC CARD (B&S)	CARTE ELECTRONIQUE (B&S)	ELEKTRONISCHE KARTE (B&S)
	27722355/0	1	SCHEDA ELETTR. (Tecumseh)	ELECTR. CARD (Tecumseh)	CARTE ELECTR. (Tecumseh)	ELEKTR. KARTE (Tecumseh)
3	27065060/0	1	CAVO	CABLE	CABLES	KABEL
4	19700046/0	1	INTERRUTTORE CAMBIO	GEARBOX SWITCH	INT. BOÎTE DE VITESSE	ANTRIEB SCHALTER
5	19410606/0	4	MICRO INTERRUTTORE	MICROSWITCH	MICROINTERRUPTEUR	MIKROSCHALTER
6	33320506/0	6	FERMACAVO	FAIRLEAD	FIXATION CABLE	KABELBEFESTIGUNG
7	27065061/0	1	CAVO MASSA (B&S)	CABLE (B&S)	CABLES (B&S)	KABEL (B&S)
	27065064/0	1	CAVO MASSA (Tecumseh)	CABLE (Tecumseh)	CABLES (Tecumseh)	KABEL (Tecumseh)
8	19410612/0	1	MICRO INTERRUTTORE (B&S)	MICROSWITCH (B&S)	MICROINTERRUPTEUR (B&S)	MIKROSCHALTER (B&S)
9	27065065/0	1	CAVO STOP (Tecumseh)	STOP CABLE (Tecumseh)	STOP CABLE (Tecumseh)	STOP KABEL (Tecumseh)

contact@mc-technoculture.com

EL63

EL63 M

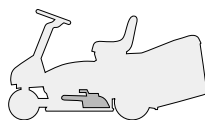

ACCESSORI A RICHIESTA
 OPTIONALS ON REQUEST
 ACCESSOIRES SUR DEMANDE
 ZUBEHOERE NACH ANFRAGE

2005

012.0

1 / 1

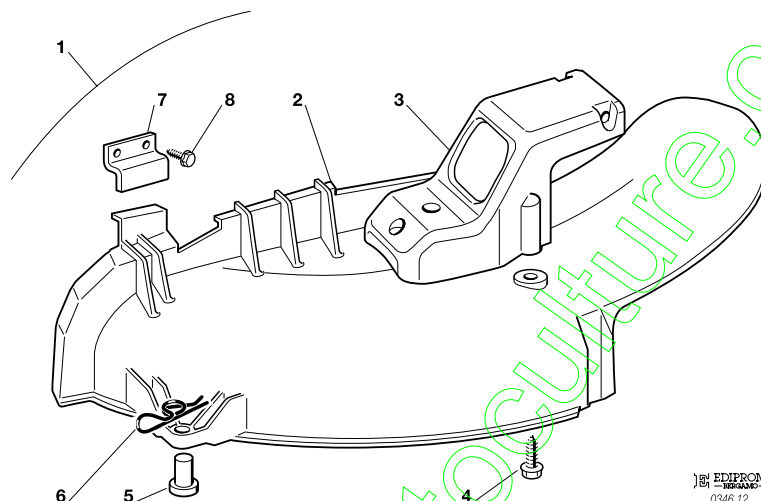

EDIPROM
 0346.12

N.	CODE	Q.TY	DESCRIZIONE	DESCRIPTION	DESCRIPTION	BESCHREIBUNG
1	99900035/0	1	KIT PER MULCHING	MULCHING KIT	KIT POUR MULCHING	VORRICHTUNG FÜR MULCHING
2	27140052/0	1	DEFLETTORE	DEFLECTOR	DEFLECTEUR	ABWEISER
3	27230201/0	1	FULCRO	FULCRUM	POINT D'APPUI	DREHPUNKT
4	12735410/0	3	VITE	SCREW	VIS	SCHRAUBE
5	25510022/0	1	PERNO	PIN	PIVOT	BOLZEN
6	24487998/0	1	COPPIGLIA	COTTER PIN	GOUPILLE	SPLIT
7	27772139/0	1	STAFFA	CLAMP	ETRIER	BRIDE
8	12735110/0	2	VITE	SCREW	VIS	SCHRAUBE

EL63

EL63 M

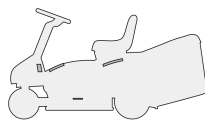

ETICHETTE
LABELS
ETIQUETTES
KLEBZETTEL

2005

013.0

1 / 1

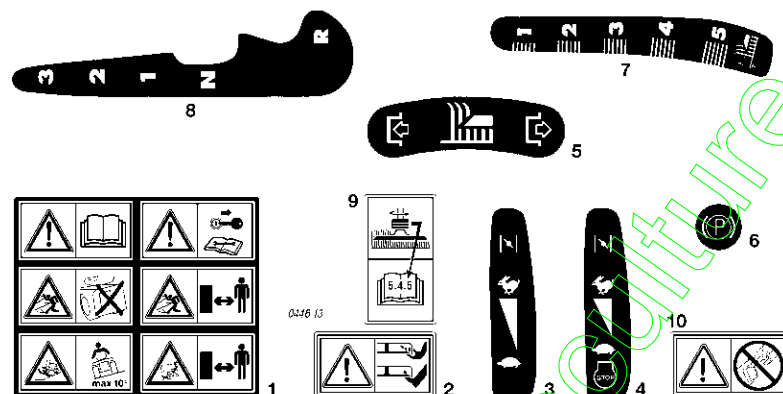

N.	CODE	Q.TY	DESCRIZIONE	DESCRIPTION	DESCRIPTION	BESCHREIBUNG
1	14357428/0	1	ETICHETTA	LABEL	ETIQUETTE	KLEBZETTEL
2	14356699/0	1	ETICHETTA	LABEL	ETIQUETTE	KLEBZETTEL
3	14358415/0	1	ETICHETTA (EL63)	LABEL (EL63)	ETIQUETTE (EL63)	KLEBZETTEL (EL63)
4	14358717/0	1	ETICHETTA (EL63 M)	LABEL (EL63 M)	ETIQUETTE (EL63 M)	KLEBZETTEL (EL63 M)
5	14358418/0	1	ETICHETTA	LABEL	ETIQUETTE	KLEBZETTEL
6	14358460/0	1	ETICHETTA	LABEL	ETIQUETTE	KLEBZETTEL
7	14358417/0	1	ETICHETTA	LABEL	ETIQUETTE	KLEBZETTEL
8	14358416/0	1	ETICHETTA	LABEL	ETIQUETTE	KLEBZETTEL
9	14358654/0	1	ETICHETTA	LABEL	ETIQUETTE	KLEBZETTEL
10	14360118/0	1	ETICHETTA	LABEL	ETIQUETTE	KLEBZETTEL