

contact@enc-motoculture.com

F 72
F 72 hydro

CATALOGO PEZZI DI RICAMBIO
SPARE PARTS CATALOGUE
CATALOGUE DE PIECES
ERSATZTEILKATALOG

2000

F72

F72 hydro

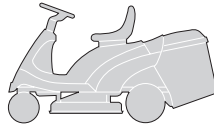

CATALOGO PARTI DI RICAMBIO
SPARE PARTS CATALOGUE
CATALOGUE DE PIECES
ERSATZTEILKATALOG

2000

000.0

1 / 7

COME USARE IL CATALOGO

HOW TO USE THE CATALOGUE

COMMENT UTILISER LE CATALOGUE

WIE IST DER KATALOG ZU BENUTZEN

1. Generalità

Questo catalogo contiene tutte le informazioni necessarie per ordinare correttamente i pezzi di ricambio.

1. General information

This catalogue contains all the information necessary for correctly ordering spare parts.

1. Généralités

Ce catalogue contient toutes les indications nécessaires pour commander correctement les pièces détachées.

1. Allgemeines

Dieser Katalog enthält alle Informationen, die für die korrekte Bestellung von Ersatzteilen erforderlich sind.

2. Struttura del catalogo

In ogni pagina del catalogo sono riportate le seguenti indicazioni:

2. Structure of the catalogue

Each page of the catalogue has these indications:

2. Structure du catalogue

Les indications suivantes sont reportées sur chaque page du catalogue:

2. Aufbau des Katalogs

Auf jeder Seite des Katalogs sind die folgenden Angaben wiedergegeben:

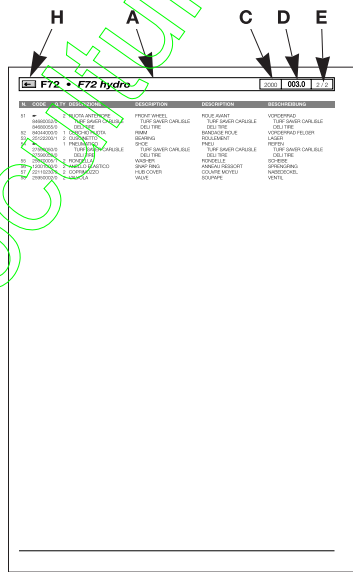
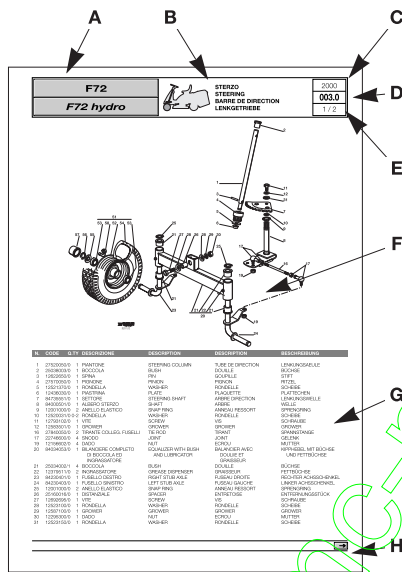

A. Macchina o serie di macchine per le quali la pagina è valida.

A. Machine or machine series to which the page applies.

A. La machine ou la série de machines auxquelles se réfère la page.

A. Maschine oder Serie der Maschine, für welche die Seite gültig ist.

B. Indicazione del gruppo con la raffigurazione in miniatura della sua collocazione sulla macchina.

B. Indication of the unit with a miniature drawing showing its position on the machine.

B. L'indication du groupe avec la représentation en miniature de sa position sur la machine.

B. Bezeichnung der Gruppe mit einer Miniaturdarstellung ihrer Anbringung auf der Maschine.

C. Anno di produzione della macchina a cui si riferisce.

C. Year of production of the machine concerned.

C. L'année de fabrication de la machine concernée.

C. Herstellungsjahr der betreffenden Maschine.

D. Numerazione progressiva della tavola, secondo il seguente criterio:

D. Progressive numbering of the table, arranged as follows:

D. La numérotation progressive du tableau, selon le critère suivant:

D. Progressive Numerierung der Tafel nach folgendem Kriterium:

- le prime due cifre indicano il numero progressivo;
- le eventuali lettere che seguono indicano le diverse versioni alternative di quel gruppo;
- la cifra dopo il punto indica un eventuale aggiornamento nel corso della annualità indicata al punto 3.

- the first two numbers are the progressive number;
- any letters that follow will indicate the various alternative versions of that unit;
- the number after the dot is for any updates during the year given at point 3.

- les deux premiers chiffres indiquent le numéro progressif;
- les éventuelles lettres qui suivent indiquent les différentes versions alternatives de ce groupe;
- le chiffre après le point indique l'éventuelle mise à jour effectuée au cours de l'année indiquée au point 3.

- die ersten zwei Ziffern bezeichnen die progressive Nummer;
- die eventuellen Buchstaben, die folgen, bezeichnen die verschiedenen alternativen Versionen dieser Gruppe;
- die Ziffer nach dem Punkt bezeichnet einen eventuellen neueren Stand im Laufe des Jahrgangs, der in Punkt 3 angegeben ist.

Esempio:

Example:

Exemple

Beispiel:

005a.0 =

005a.0 =

005a.0 =

005a.0 =

005 Gruppo Motore
a 8,5 HP B&S
.0 Prima stesura

005 Engine unit
a 8.5 HP B&S
.0 First copy

005 Groupe Moteur
a 8,5 CH B&S
.0 Première rédaction

005 Motorgruppe
a 8,5 PS B&S
.0 Erste Ausgabe



E. Numero della pagina e numero totale delle pagine necessarie per la descrizione del gruppo.

E. Page number and total number of pages necessary for the description of the unit.

E. Numéro de la page et nombre total des pages nécessaires pour la description du groupe.

E. Seitenzahl und Gesamtzahl der Seiten, die für die Beschreibung der Gruppe erforderlich sind.

F. Vista esplosa del gruppo.

F. Exploded view of the unit.

F. Vue éclatée du groupe.

F. Explosionszeichnung der Gruppe.

G. Descrizione completa dei singoli particolari, con codice e quantità di pezzi.

G. Full description of each part, with code number and number of pieces.

G. Description complète de chaque élément, avec code et quantité des pièces.

G. Vollständige Beschreibung der Einzelteile, mit Kodenummer und Menge der Teile.

H. Indicazione della presenza di altre pagine di seguito.

H. Indication of additional pages.

H. Indication de la présence d'autres pages successives.

H. Angabe über die Präsenz weiterer folgender Seiten.

Nelle pagine di seguito, sono riportate nuovamente le indicazioni relative ai punti A - C - D - E - G e H.

The additional pages repeat the indications as at points A - C - D - E - G and H.

Les pages qui suivent reportent, elles aussi, les indications concernant les points A - C - D - E - G et H.

Auf den nachfolgenden Seiten sind die Bezeichnungen, die sich auf die Punkte A - C - D - E - G und H beziehen, erneut wiedergegeben.

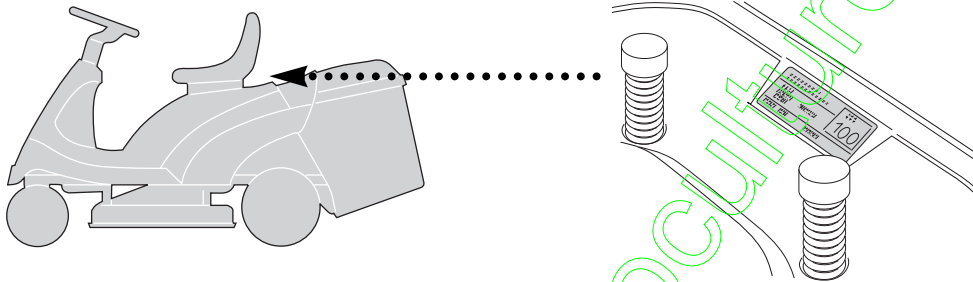

3. Ordine di ricambi

3. Spare parts order

3. Commande pièces détachées

3. Ersatzteilbestellungen

Prima di formulare un ordine di ricambi, accertare che il catalogo corrisponda all'anno di costruzione della macchina, e riportato sulla targhetta di identificazione.

Before putting in an order for spare parts, make sure that the catalogue is the one applying to the machine's year of manufacture, as shown on the identification plate attached to the machine.

Avant de passer une commande pour des pièces détachées, s'assurer que le catalogue est celui correspondant à l'année de fabrication de la machine reportée sur la plaquette d'identification.

Ehe eine Ersatzteilbestellung geschrieben wird, muß man sich vergewissern, daß der Katalog mit dem Herstellungsjahr der Maschine übereinstimmt, oder mit dem auf dem Kennzeichenschild wiedergegeben.

Ogni ordine di ricambi deve necessariamente contenere:

Each spare parts order must include:

Chaque commande de pièces détachées doit obligatoirement contenir:

Jede Ersatzteilbestellung muß enthalten:

- modello della macchina;
- quantità di pezzi richiesta;
- descrizione (eventuale);
- numero di codice del pezzo;
- destinatario
- mezzo di spedizione.

- the model of the machine;
- the number of parts required;
- description (incidental);
- the code number for the item;
- the destination;
- the method of shipping.

- modèle de la machine;
- quantité de pièces demandée;
- description (éventuelle);
- numéro de code de la pièce;
- le destinataire;
- le moyen de transport.

- Modell der Maschine;
- Menge der angeforderten Teile;
- Bezeichnung (eventuell);
- Artikelnummer des Teils;
- Empfänger;
- Versandart.

Esempio di ordinazione:

An example of an order:

Exemple de commande:

Beispiel einer Bestellung:

Su una macchina F72 del 2000, con motore B&S da 8,5 HP si deve sostituire la protezione del silenziatore. Tale particolare è raffigurato nella tavola **005a.0** alla posizione **8**, a cui corrisponde il codice **82598053/0**.

The muffler protection on a F72 machine, produced in 2000 with an B&S 8.5 HP engine, must be replaced. This part is shown in table **005a.0** in position **8**, and has the code number **82598053/0**.

Sur une machine F72 du 2000, avec moteur B&S de 8,5 CH, il faut remplacer la protection silencieux. Cette pièce est représentée sur le tableau **005a.0** à la position **8**, correspondant au code **82598053/0**.

Auf einer Maschine F72 von 2000, mit Motor B&S mit 8,5 PS muß der Auspuffschutz ersetzt werden. Dieses Einzelteil ist auf der Tafel **005a.0** unter der Position **8** dargestellt, der dem Code **82598053/0** entspricht.

L'ordinazione sarà quindi:

The order will therefore be:

La commande sera donc formulée de la façon suivante:

Die Bestellung lautet demnach:

per F72:
n. 1 protezione cod. 82598053/0 da inviare a
a mezzo

for F72:
1 protection - code 82598053/0 to be sent to
method of shipping

pour F72:
1 protection - code 82598053/0 à envoyer à
par

Für F72:
1 Schutz - Kode 82598053/0 zu versenden an
mit

Nota

Note

Remarque

Anmerkung

Per le parti non codificate del motore e della trasmissione contrassegnate con (*), occorre rivolgersi al Costruttore.

For parts of the engine and the transmission without code numbers, marked by (*), it's necessary to contact the manufacturer.

Pour les pièces non codées du moteur et de la transmission, indiquées avec (*), il faut s'adresser au Fabricant.



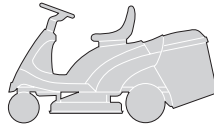

Für die nicht codierten Teile des Motors und des Antriebs, die mit (*) gekennzeichnet sind, muß man sich an den Hersteller wenden.

F72**F72 hydro**
INDICE DELLE TAVOLE
INDEX OF TABLES
SOMMAIRE DES TABLEAUX
INHALT DER TAFELN

2000

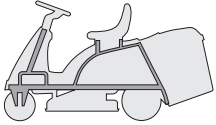
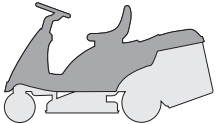
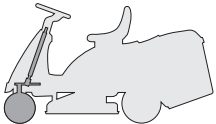
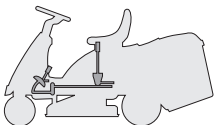
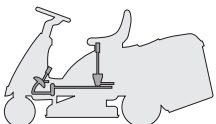
000.0

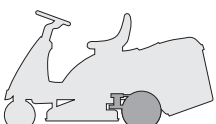
3 / 7

GRUPPO / UNIT / GROUPE / GRUPPE		F72	F72 hydro
	TELAIO CHASSIS CHASSIS RAHMENSATZ	001	001
	CORROZZERIA BODY CARROSSERIE KARROSSERIE	002	002
	STERZO STEERING BARRE DE DIRECTION LENKGETRIEBE	003	003
	COMANDO FRENO E COMANDO CAMBIO BRAKE AND GEARBOX CONTROLS COMMANDE FREIN ET BOITE DE VITESSE BREMSE UND WECHSEL ANTRIEB	004M	-
	COMANDO TRASMISSIONE E FRENO DRIVE AND BRAKE CONTROLS COMMANDE TRANSMISSION ET FREIN GETRIEBE UND BREMSE ANTRIEB	-	004Y
	MOTORE ENGINE MOTEUR MOTOR 10,5 HP B&S	005	005
	8,5 HP B&S	005a	005a
	10 HP TECUMSEH	005b	005b
	TRASMISSIONE TRANSMISSION TRANSMISSION GETRIEBE	006M	006Y
	SOLLEVAMENTO PIATTO DI TAGLIO CUTTING PLATE LIFTING SOULEVEMENT PLATEAU DE COUPE SCHNEIDWERKZEUG AUFHEBESATZ	007	007
	PIATTO DI TAGLIO (1) CUTTING PLATE (1) PLATEAU DE COUPE (1) SCHNEIDWERKZEUG (1)	008	008



GRUPPO / UNIT / GROUPE / GRUPPE

F72

F72 hydro

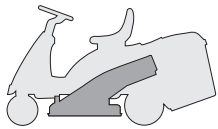

PIATTO DI TAGLIO (2)
CUTTING PLATE (2)
PLATEAU DE COUPE (2)
SCHNEIDWERKZEUG (2)

009

009

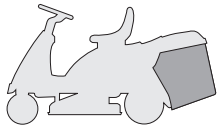

SACCO
GRASSCATCHER
BAC
AUFFANGSACK

010

010

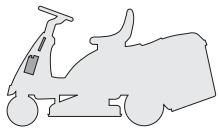

PARTI ELETTRICHE
ELECTRICAL PARTS
PARTIES ELECTRIQUES
ELETRISCHETEILE

011M

011Y

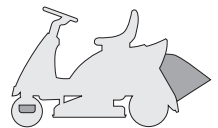

ACCESSORI A RICHIESTA
OPTIONALS ON REQUEST
ACCESSOIRES SUR DEMANDE
ZUBEHOERE NACH ANFRAGE

012

012

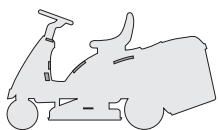

ETICHETTE
LABELS
ETIQUETTES
KLEBZETTEL

013

013

SCHEMA ELETTRICO
WIRE DIAGRAM
SCHEMA ELECTRIQUE
ELEKTRISCHES SCHEMA
10,5 - 8,5 HP B&S - 10 HP TECUMSEH

014M

014Y

contact@enc-motoculture.com

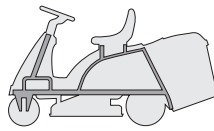
F72**F72 hydro**
TELAIO
CHASSIS
CHASSIS
RAHMENSATZ

2000

001.0

1 / 2

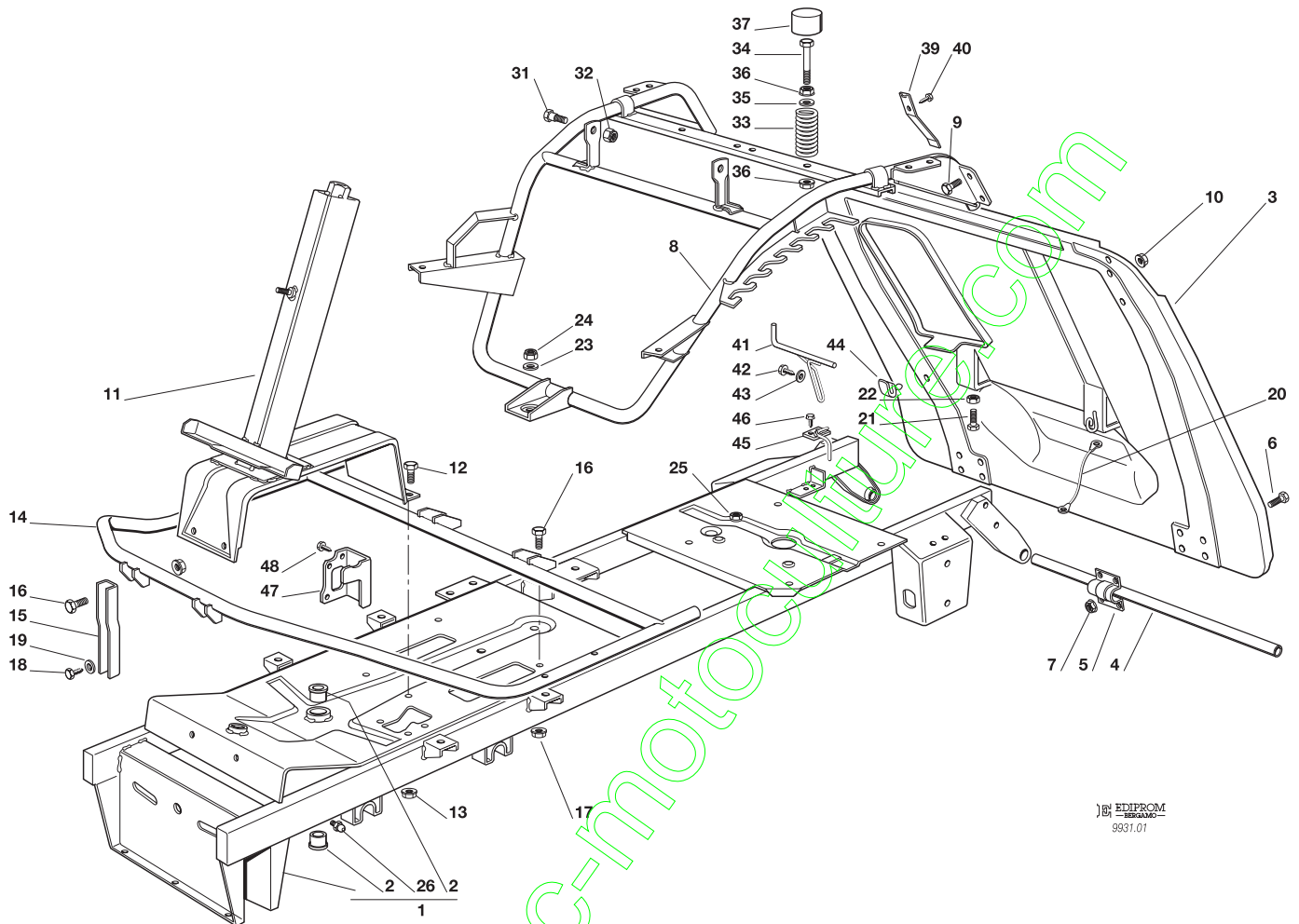

 EDIPROM
 9931.01

N.	CODE	Q.TY	DESCRIZIONE	DESCRIPTION	DESCRIPTION	BESCHREIBUNG
1	84801113/0	1	TELAIO	CHASSIS	CHASSIS	RAHMENSATZ
2	25034002/1	2	BOCCOLA	BUSH	DOUILLE	BÜCHSE
3	84545051/3	1	PIASTRA	PLATE	PLAQUE	PLATTE
4	27037000/0	1	PERNO	PIN	PIVOT	BOLZEN
5	25547012/1	2	PIASTRA	PLATE	PLAQUE	PLATTE
6	12791200/0	8	VITE	SCREW	VIS	SCHRAUBE
7	12292102/0	8	DADO	NUT	ECROU	MUTTER
8	84801111/0	1	TELAIO SEDILE	CHASSIS	CHASSIS	RAHMENSATZ
9	12792611/0	4	VITE	SCREW	VIS	SCHRAUBE
10	12293201/0	4	DADO	NUT	ECROU	MUTTER
11	84783009/0	1	SUPPORTO PIANTONE	SUPPORT	SUPPORT	HALTER
12	12792611/0	4	VITE	SCREW	VIS	SCHRAUBE
13	12293201/0	4	DADO	NUT	ECROU	MUTTER
14	84801107/2	1	SUPPORTO PEDANE	FOTTBOARD SUPPORT	SUPPORT MARCHEPIED	FUSSBRETTHALTER
15	27787025/0	2	SUPPORTO	SUPPORT	SUPPORT	HALTER
16	12792611/0	4	VITE	SCREW	VIS	SCHRAUBE
17	12293201/0	4	DADO	NUT	ECROU	MUTTER
18	12734995/0	2	VITE	SCREW	VIS	SCHRAUBE
19	12521331/0	2	RONDELLA	WASHER	RONDELLE	SCHEIBE
20	84040300/0	1	CAVO AGGANCI	CORD	CORDE	SEIL
21	12793701/0	2	VITE	SCREW	VIS	SCHRAUBE
22	12293200/0	2	DADO	NUT	ECROU	MUTTER
23	12523060/0	1	RONDELLA	WASHER	RONDELLE	SCHEIBE
24	12155000/0	1	DADO	NUT	ECROU	MUTTER
25	12500090/0	1	DADO	NUT	ECROU	MUTTER
26	12379511/0	2	INGRASSATORE	GREASE DISPENSER	GRAISSEUR	FETTBUCHSE
31	22524970/1	2	PERNO	PIN	PIVOT	BOLZEN
32	12155010/0	2	DADO	NUT	ECROU	MUTTER
33	25430205/0	2	MOLLA	SPRING	RESSORT	FEDER
34	25943001/0	2	VITE	SCREW	VIS	SCHRAUBE
35	12521350/0	2	RONDELLA	WASHER	RONDELLE	SCHEIBE

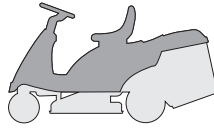

N.	CODE	Q.TY	DESCRIZIONE	DESCRIPTION	DESCRIPTION	BESCHREIBUNG
36	12293201/0	4	DADO	NUT	ECROU	MUTTER
37	25122000/1	2	CUFFIA	HOOD	PROTECTEUR	SCHUTZKASTEN
39	27430554/0	1	MOLLA	SPRING	RESSORT	FEDER
40	12728440/0	1	VITE	SCREW	VIS	SCHRAUBE
41	27294001/0	1	GUIDA	GUIDE	GUIDE	FÜHRUNG
42	12735120/0	1	VITE	SCREW	VIS	SCHRAUBE
43	12523040/0	1	RONDELLA	WASHER	RONDELLE	SCHEIBE
44	33320506/0	1	FERMACAVO	FAIRLED	FIXATION CABLE	KABELBEFESTIGUNG
45	27294002/0	1	GUIDACINGHIA	BELT GUIDE	GUIDE DE CURROIRE	RIEMENFÜHRUNG
46	12735110/0	2	VITE	SCREW	VIS	SCHRAUBE
47	27772095/0	1	STAFFA	CLAMP	ETRIER	BRIDE
48	12735106/0	2	VITE	SCREW	VIS	SCHRAUBE

contact@enc-motoculture.com

F72**F72 hydro**
CARROZZERIA
BODY
CARROSSERIE
KARROSSERIE

2000

002.0

1 / 2

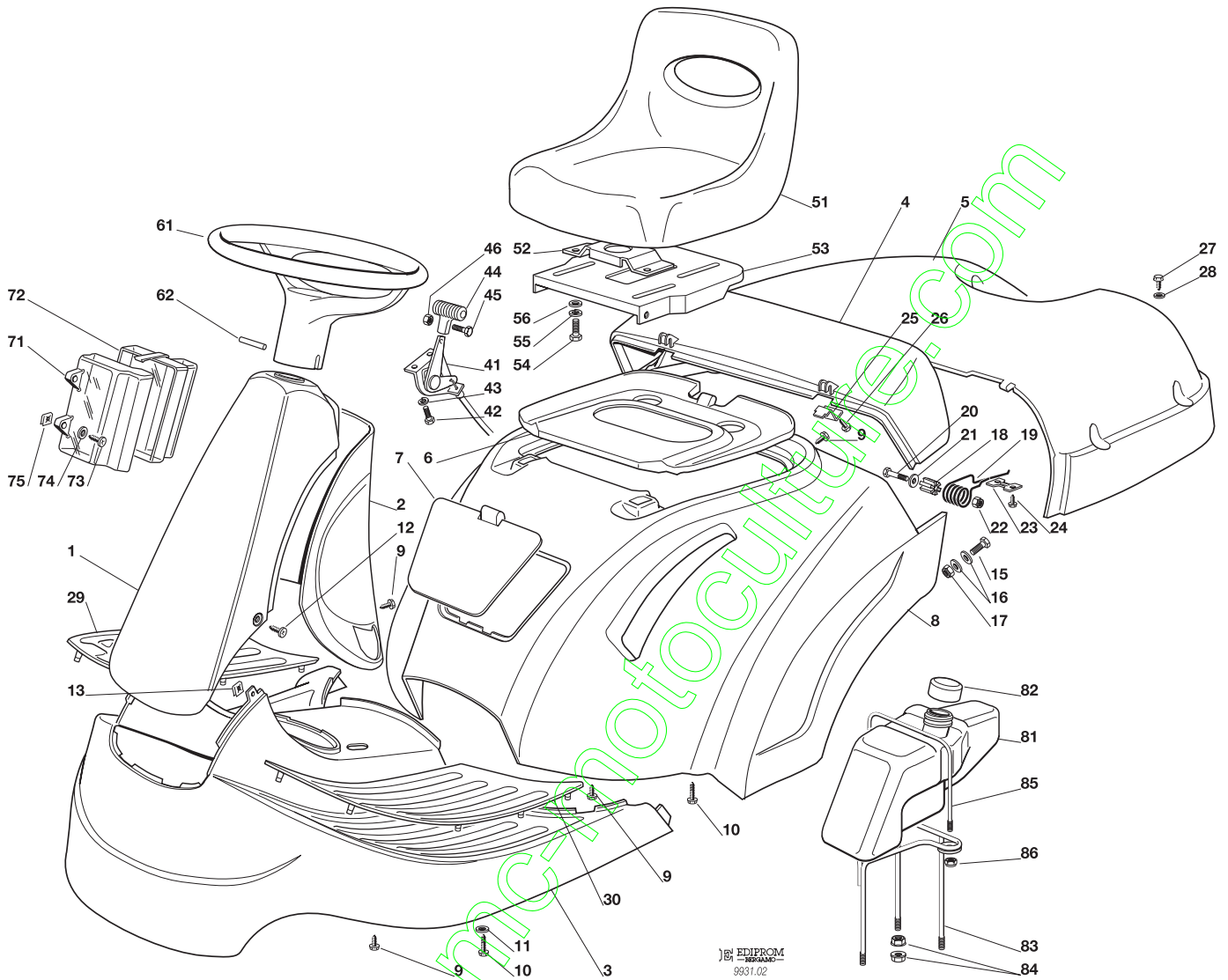

N.	CODE	Q.TY	DESCRIZIONE	DESCRIPTION	DESCRIPTION	BESCHREIBUNG
1	☛	1	PROTEZIONE ANTERIORE	FRONT COVER	COUVERCLE AVANT	VORDERDECKEL
	84598064/0		ROSSO	RED	ROUGE	ROT
	84598065/0		VERDE	GREEN	VERT	GRÜN
	84598066/0		GIALLO	YELLOW	JAUNE	GELB
	84598067/0		BLU	BLUE	BLEU	BLAU
	84598075/0		ARANCIONE	ORANGE	ORANGE	DUNKELORANGE
2	☛	1	PROTEZIONE POSTERIORE	REAR COVER	COUVERCLEARRIER	HINTERDECKEL
	27600091/0		ROSSO	RED	ROUGE	ROT
	27600092/0		VERDE	GREEN	VERT	GRÜN
	27600093/0		GIALLO	YELLOW	JAUNE	GELB
	27600094/0		BLU	BLUE	BLEU	BLAU
	27600108/0		ARANCIONE	ORANGE	ORANGE	DUNKELORANGE
3	☛	1	COPERTURA PEDANA	FOOTBOARD COVER	COUVRE MARCHEPIED	FUSSBRETTDECKEL
	27110300/2		ROSSO	RED	ROUGE	ROT
	27110309/2		VERDE	GREEN	VERT	GRÜN
	27110310/2		GIALLO	YELLOW	JAUNE	GELB
	27110311/2		BLU	BLUE	BLEU	BLAU
	27110345/0		ARANCIONE	ORANGE	ORANGE	DUNKELORANGE
4	☛	1	COPERTURA SACCO FISSA	GRASS-CATCHER COVER, FIXED	COUVRE-BAC FIXE	FESTER SACKKAPPE
	27110302/1		ROSSO	RED	ROUGE	ROT
	27110317/1		VERDE	GREEN	VERT	GRÜN
	27110318/1		GIALLO	YELLOW	JAUNE	GELB
	27110319/1		BLU	BLUE	BLEU	BLAU
	27110348/0		ARANCIONE	ORANGE	ORANGE	DUNKELORANGE
5	☛	1	COPERTURA SACCO MOBILE	GRASS-CATCHER COVER, MOBILE	COUVRE-BAC MOBILE	BEWEGLICHER SACKKAPPE
	27110303/0		ROSSO	RED	ROUGE	ROT



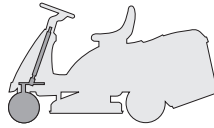

N.	CODE	Q.TY	DESCRIZIONE	DESCRIPTION	DESCRIPTION	BESCHREIBUNG
	27110321/0		VERDE	GREEN	VERT	GRÜN
	27110322/0		GIALLO	YELLOW	JAUNE	GELB
	27110323/0		BLU	BLUE	BLEU	BLAU
	27110349/0		ARANCIONE	ORANGE	ORANGE	DUNKELORANGE
6	27110306/0	1	COPERTURA MOTORE	ENGINE COVER	COUVRE MOTEUR	MOTORKAPPE
7	27109501/0	1	COPERCHIO ANTERIORE	FRONT COVER	COUVERCLE AVANT	DECKEL
	27109505/0		ROSSO	RED	ROUGE	ROT
	27109506/0		VERDE	GREEN	VERT	GRÜN
	27109507/0		GIALLO	YELLOW	JAUNE	GELB
	27109514/0		BLU	BLUE	BLEU	BLAU
	27109514/0		ARANCIONE	ORANGE	ORANGE	DUNKELORANGE
8	84110100/1	1	COPERTURA RUOTE	WHEELS COVER	COUVRE ROUES	RADENKAPPE
	84110102/1		ROSSO	RED	ROUGE	ROT
	84110103/1		VERDE	GREEN	VERT	GRÜN
	84110104/1		GIALLO	YELLOW	JAUNE	GELB
	84110104/1		BLU	BLUE	BLEU	BLAU
	84110125/0		ARANCIONE	ORANGE	ORANGE	DUNKELORANGE
8	84110107/1	1	COPERTURA RUOTE (hydro)	WHEELS COVER (hydro)	COUVRE ROUES (hydro)	RADENKAPPE (hydro)
	84110109/1		ROSSO	RED	ROUGE	ROT
	84110110/1		VERDE	GREEN	VERT	GRÜN
	84110111/1		GIALLO	YELLOW	JAUNE	GELB
	84110111/1		BLU	BLUE	BLEU	BLAU
	84110126/0		ARANCIONE	ORANGE	ORANGE	DUNKELORANGE
9	12735402/0	10	VITE	SCREW	VIS	SCHRAUBE
10	12735410/0	8	VITE	SCREW	VIS	SCHRAUBE
11	12523040/0	2	RONDELLA	WASHER	RONDELLE	SCHRAUBE
12	12735598/0	2	VITE	SCREW	VIS	SCHRAUBE
13	12437503/0	2	PIASTRINA	PLATE	PLAQUE	PLATTE
15	12791200/0	2	VITE	SCREW	VIS	SCHRAUBE
16	12523040/0	2	RONDELLA	WASHER	RONDELLE	SCHRAUBE
17	12154510/0	2	DADO	NUT	ECROU	MUTTER
18	27047003/0	2	BUSSOLA	BUSH	DOUILLE	BUCHSE
19	27430551/1	2	MOLLA	SPRING	RESSORT	FEDER
20	12691200/0	2	VITE	SCREW	VIS	SCHRAUBE
21	12523070/0	2	RONDELLA	WASHER	RONDELLE	SCHRAUBE
22	12155000/0	2	DADO	NUT	ECROU	MUTTER
23	27546001/0	2	PIASTRINA	PLATE	PLAQUE	PLATTE
24	12735402/0	4	VITE	SCREW	VIS	SCHRAUBE
25	27546003/0	2	PIASTRINA	PLATE	PLAQUE	PLATTE
26	12735402/0	2	VITE	SCREW	VIS	SCHRAUBE
27	12729601/0	4	VITE	SCREW	VIS	SCHRAUBE
28	12521331/0	4	RONDELLA	WASHER	RONDELLE	SCHRAUBE
29	27110304/0	1	COPRIPEDANA DESTRA	RIGHT FOOTBOARD COVER	COUVRE MARCHEPIED DRO.	RECHTE FUSSBRETTDECKEL
30	27110305/0	1	COPRIPEDANA SINISTRA	LEFT FOOTBOARD COVER	COUVRE MARCHEPIED GAU.	LINKE FUSSBRETTDECKEL
41	84000250/0	1	ACCELERATORE	ACCELERATOR	ACCELERATEUR	GAS ZUG
42	12788512/0	2	VITE	SCREW	VIS	SCHRAUBE
43	12581200/0	2	GROWER	GROWER	GROWER	GROWER
44	25394501/0	1	MANOPOLINA	HANDLE	POIGNE	GRIF
45	12726388/0	1	VITE	SCREW	VIS	SCHRAUBE
46	12290800/0	1	DADO	NUT	ECROU	MUTTER
51	25722453/1	1	SEDILE	SEAT	SIEGE	SITZ
52	25785114/0	1	SUPPORTO	SUPPORT	SUPPORT	HALTER
53	25547033/0	1	PIASTRA	PLATE	PLAQUE	PLATTE
54	12793101/0	4	VITE	SCREW	VIS	SCHRAUBE
55	12583500/0	4	GROWER	GROWER	GROWER	GROWER
56	12523060/0	4	RONDELLA	WASHER	RONDELLE	SCHRAUBE
61	25961201/0	1	VOLANTE	STEERING WHEEL	VOLANT	LENKRAD
62	12620299/0	1	SPINA	PIN	GOUPILLE	STIFT
71	25600020/0	1	PROTEZIONE SUPERIORE	UPPER GUARD	PROTECTION SUPERIEUR	OBERSCHUTZ
72	25600021/1	1	PROTEZIONE INFERIORE	LOWER GUARD	PROTECTION INFERIEUR	UNTERSCHUTZ
73	12728460/0	2	VITE	SCREW	VIS	SCHRAUBE
74	12521320/0	2	ROSETTA	WASHER	RONDELLE	SCHRAUBE
75	12437502/0	2	PIASTRINA	PLATE	PLAQUE	SCHRAUBE
81	27733000/2	1	SERBATOIO	TANK	RESERVOIR	PLATTE
82	25795000/0	1	TAPPO	CAP	BOUCHON	TANK
83	84783005/1	1	SUPPORTO	SUPPORT	SUPPORT	TANKVERSCHLUSS
84	12293201/0	6	DADO	NUT	ECROU	HALTER
85	27034056/0	1	ASTA	ROD	TIGE	MUTTER
86	12154510/0	2	DADO	NUT	ECROU	MUTTER

F72**F72 hydro**
STERZO
STEERING
BARRE DE DIRECTION
LENKGETRIEBE

2000

003.0

1 / 2

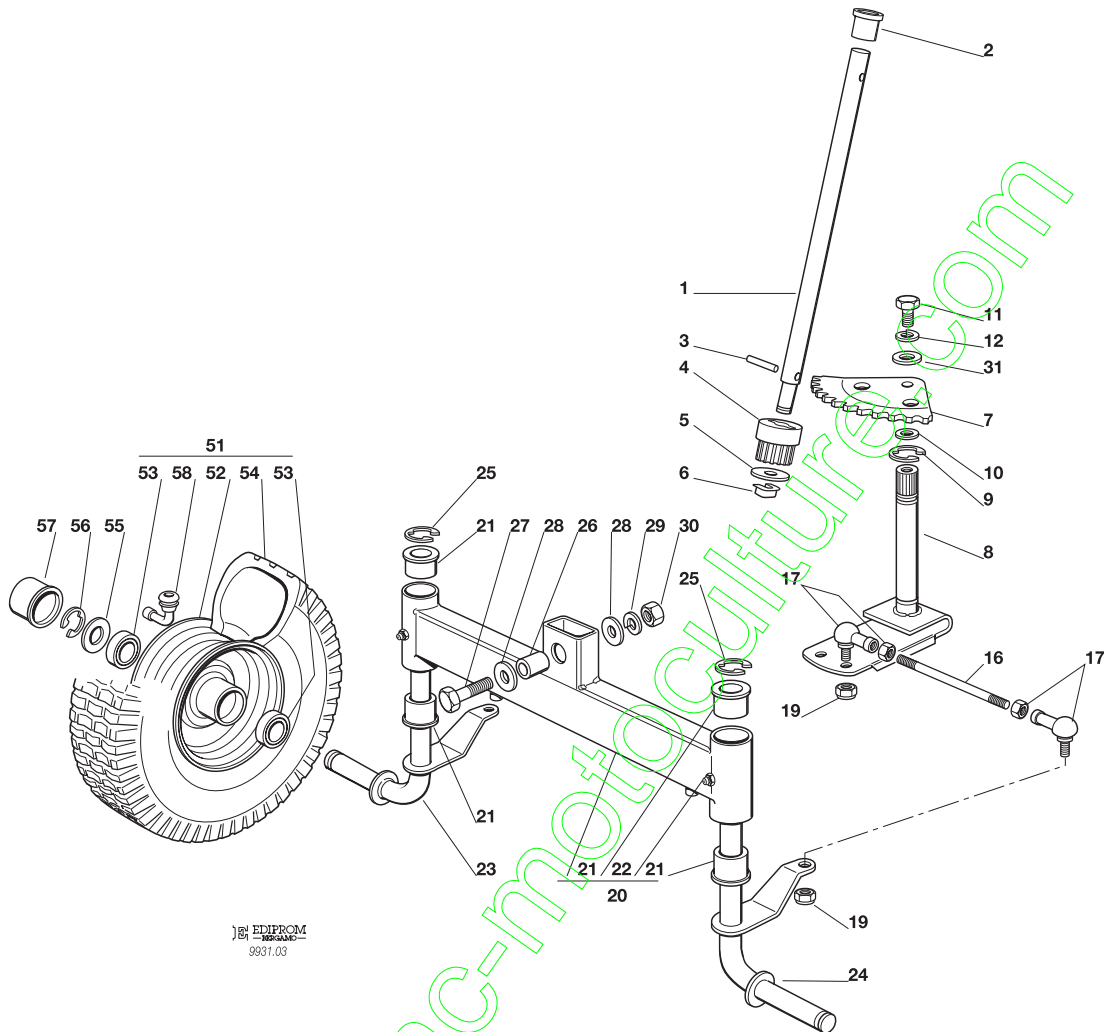
 EDIPROM
 9931.00

N.	CODE	Q.TY	DESCRIZIONE	DESCRIPTION	DESCRIPTION	BESCHREIBUNG
1	27520050/0	1	PIANTONE	STEERING COLUMN	TUBE DE DIRECTION	LENKUNGSAEULE
2	25038003/0	1	BOCCOLA	BUSH	DOUILLE	BÜCHSE
3	12622650/0	1	SPINA	PIN	GOUPILLE	STIFT
4	27570050/0	1	PIGNONE	PINION	PIGNON	RITZEL
5	12521370/0	1	RONDELLA	WASHER	RONDELLE	SCHEIBE
6	12436030/0	1	PIASTRINA	PLATE	PLAQUETTE	PLATTECHEN
7	84735551/0	1	SETTORE	STEERING SHAFT	ARBRE DIRECTION	LENKUNGSWELLE
8	84000501/0	1	ALBERO STERZO	SHAFT	ARBRE	WELLE
9	12001000/0	2	ANELLO ELASTICO	SNAP RING	ANNEAU RESSORT	SPRENGRING
10	12520031/0	0-2	RONDELLA	WASHER	RONDELLE	SCHEIBE
11	12793102/0	1	VITE	SCREW	VIS	SCHRAUBE
12	12583501/0	1	GROWER	GROWER	GROWER	GROWER
16	27840050/0	2	TIRANTE COLLEG. FUSELLI	TIE ROD	TIRANT	SPANNSTANGE
17	22746600/0	4	SNODO	JOINT	JOINT	GELENK
19	12156602/0	4	DADO	NUT	ECROU	MUTTER
20	84034053/0	1	BILANCIERE COMPLETO DI BOCCOLA ED INGRASSATORE	EQUALIZER WITH BUSH AND LUBRICATOR	BALANCIER AVEC DOULIIE ET GRAISSEUR	KIPPHEBEL MIT BÜCHSE UND FETTBUCHSE
21	25034002/1	4	BOCCOLA	BUSH	DOUILLE	BÜCHSE
22	12379511/0	2	INGRASSATORE	GREASE DISPENSER	GRAISSEUR	FETTBUCHSE
23	84230401/0	1	FUSELLO DESTRO	RIGHT STUB AXLE	FUSEAU DROITE	RECHTER ACHSSCHENKEL
24	84230403/0	1	FUSELLO SINISTRO	LEFT STUB AXLE	FUSEAU GAUCHE	LINKER ACHSSCHENKEL
25	12001000/0	2	ANELLO ELASTICO	SNAP RING	ANNEAU RESSORT	SPRENGRING
26	25160016/0	1	DISTANZIALE	SPACER	ENTRETOISE	ENTFERNUNGSSTÜCK
27	12692695/0	1	VITE	SCREW	VIS	SCHRAUBE
28	12523100/0	1	RONDELLA	WASHER	RONDELLE	SCHEIBE
29	12587100/0	1	GROWER	GROWER	GROWER	GROWER
30	12295300/0	1	DADO	NUT	ECROU	MUTTER
31	12523150/0	1	RONDELLA	WASHER	RONDELLE	SCHEIBE





N.	CODE	Q.TY	DESCRIZIONE	DESCRIPTION	DESCRIPTION	BESCHREIBUNG
51	☛ 84680052/0 84680055/0	2	RUOTA ANTERIORE TURF SAVER CARLISLE DELI TIRE	FRONT WHEEL TURF SAVER CARLISLE DELI TIRE	ROUE AVANT TURF SAVER CARLISLE DELI TIRE	VORDERRAD TURF SAVER CARLISLE DELI TIRE
52	84044000/0	2	CERCHIO RUOTA	RIMM	BANDAGE ROUE	VORDERRAD FELGER
53	25122200/1	4	CUSCINETTO	BEARING	ROULEMENT	LAGER
54	☛ 27590050/0 27590052/0	2	PNEUMATICO TURF SAVER CARLISLE DELI TIRE	SHOE TURF SAVER CARLISLE DELI TIRE	PNEU TURF SAVER CARLISLE DELI TIRE	REIFEN TURF SAVER CARLISLE DELI TIRE
55	25670005/1	2	RONDELLA	WASHER	RONDELLE	SCHEIBE
56	12001000/0	2	ANELLO ELASTICO	SNAP RING	ANNEAU RESSORT	SPRENGRING
57	22110230/0	2	COPRIMOZZO	HUB COVER	COUVRE MOYEU	NABEDECKEL
58	25950002/0	2	VALVOLA	VALVE	SOUPAPE	VENTIL

contact@enc-motoculture.com

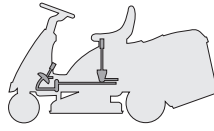
F72*F72 hydro*

COMANDO FRENO E COMANDO CAMBIO
BRAKE AND GEARBOX CONTROLS
COMMANDE FREIN ET BOITE DE VITESSE
BREMSE UND WECHSEL ANTRIEB

2000

004M.0

1 / 2

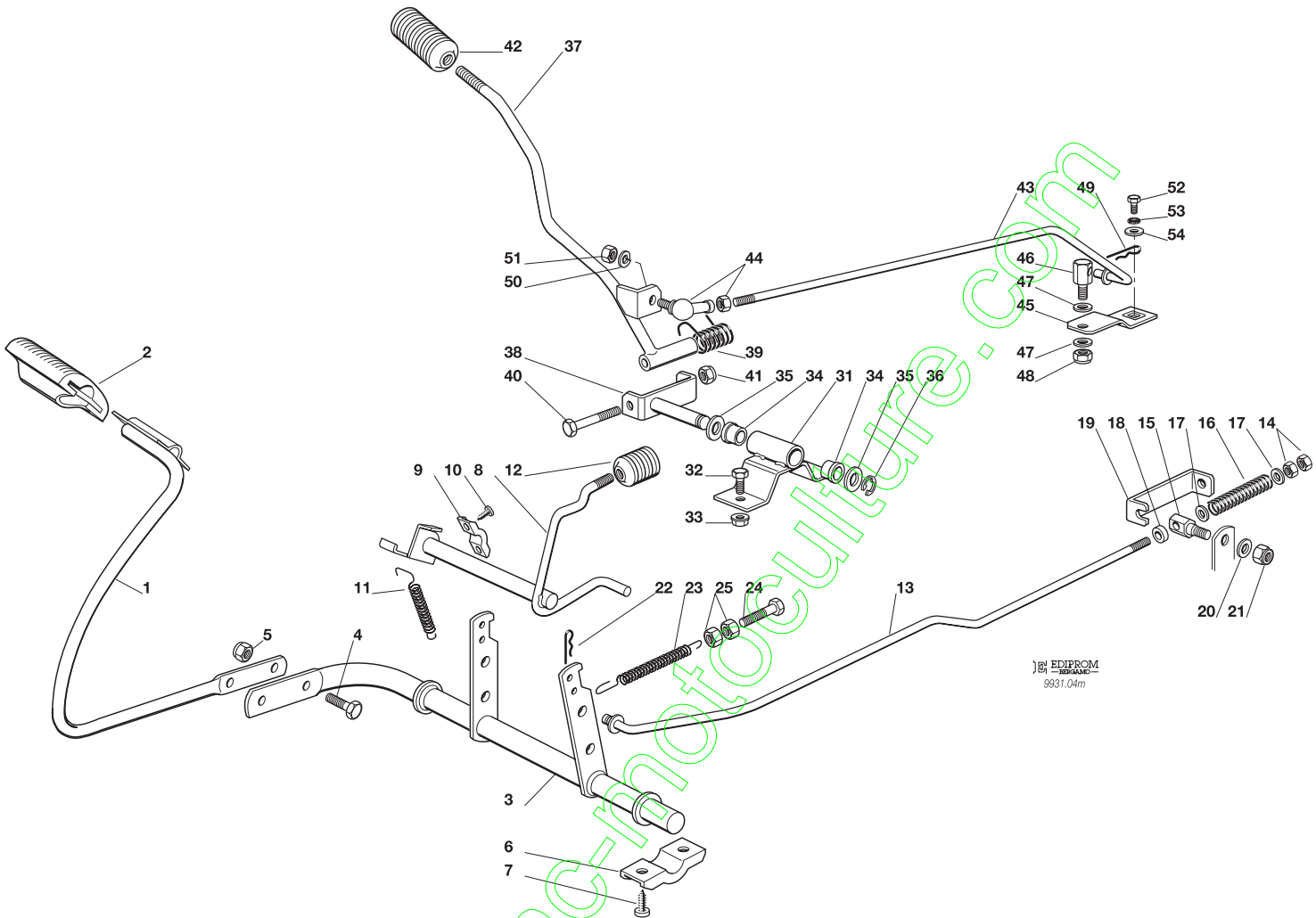

N.	CODE	Q.TY	DESCRIZIONE	DESCRIPTION	DESCRIPTION	BESCHREIBUNG
1	84503001/0	1	PEDALE	PEDAL	PEDAL	PEDAL
2	25110269/0	1	COPRISTAFFA	CLAMP COVER	COUVRE ETRIER	BRIDEDECKEL
3	84001015/1	1	ASSE FRENO	AXLE	AXE	ACHSE
4	12793301/0	2	VITE	SCREW	VIS	SCHRAUBE
5	12155000/0	2	DADO	NUT	ECROU	MUTTER
6	27546015/0	2	PIASTRINA	PLATE	PLAQUE	PLATTE
7	12731350/0	4	VITE	SCREW	VIS	SCHRAUBE
8	84001011/2	1	ASSE FRENO STAZIONAM	AXLE	AXE	ACHSE
9	25547049/0	2	PIASTRINA	PLATE	PLAQUE	PLATTE
10	12731601/0	4	VITE	SCREW	VIS	SCHRAUBE
11	27430552/0	1	MOLLA	SPRING	RESSORT	FEDER
12	27395050/0	1	MANOPOLA	KNOB	POIGNEE	KNOPF
13	27034059/0	1	ASTA	ROD	BARRE	STANGE
14	12293200/0	2	DADO	NUT	ECROU	MUTTER
15	27510103/0	1	PERNO	PIN	PIVOT	BOLZEN
16	25430236/0	1	MOLLA	SPRING	RESSORT	FEDER
17	12521350/0	2	ROSETTA	WASHER	RONDELLE	SCHIEBE
18	22171001/0	1	DISTANZIALE	SPACER	ENTRETOISE	ENTFERNUNGSSTÜCK
19	25774275/0	1	STAFFA	CLAMP	ETRIER	BRIDE
20	12523050/0	1	ROSETTA	WASHER	RONDELLE	SCHIEBE
21	12154510/0	1	DADO	NUT	ECROU	MUTTER
22	24487997/0	1	COPPIGLIA	COTTER PIN	GOUPILLE	SPLIT
23	25430220/0	1	MOLLA	SPRING	RESSORT	FEDER
24	22943005/0	1	VITE	SCREW	VIS	SCHRAUBE
25	12293200/0	2	DADO	NUT	ECROU	MUTTER
31	84773551/0	1	STAFFA	CLAMP	ETRIER	BRIDE
32	12793102/0	1	VITE	SCREW	VIS	SCHRAUBE
33	12293201/0	1	DADO	NUT	ECROU	MUTTER
34	27047002/0	2	BUSSOLA	BUSHING	DOUILLE	LAGER





N.	CODE	Q.TY	DESCRIZIONE	DESCRIPTION	DESCRIPTION	BESCHREIBUNG
35	12521370/0	2	RONDELLA	WASHER	RONDELLE	SCHEIBE
36	12608600/0	1	SEEGER	SEEGER	SEEGER	SEEGER
37	84317051/1	1	LEVA	GEARSHIFT	LEVIER	HEBEL
38	84773553/0	1	STAFFA	CLAMP	ETRIER	BRIDE
39	25430226/0	1	MOLLA	SPRING	RESSORT	FEDER
40	12692050/0	1	VITE	SCREW	VIS	SCHRAUBE
41	12155000/0	1	DADO	NUT	ECROU	MUTTER
42	25394503/1	1	MANOPOLA	KNOB	POIGNEE	WECHSEL
43	27034052/0	1	ASTA	ROD	BARRE	STANGE
44	22746601/0	2	SNODO	JOINT	JOINT	GELENK
45	27315077/0	1	LEVA	GEARSHIFT	LEVIER	HEBEL
46	25510040/1	1	PERNO	PIN	PIVOT	BOLZEN
47	25670011/0	2	RONDELLA	WASHER	RONDELLE	SCHEIBE
48	12155000/0	1	DADO	NUT	ECROU	MUTTER
49	24487997/0	1	COPPILIA	COTTER PIN	GOUPILLE	SPLIT
50	12583500/0	1	GROWER	GROWER	GROWER	GROWER
51	12293200/0	1	DADO	NUT	ECROU	MUTTER
52	12735520/0	1	VITE	SCREW	VIS	SCHRAUBE
53	12540040/0	1	RONDELLA	WASHER	RONDELLE	SCHEIBE
54	22680009/0	1	RONDELLA	WASHER	RONDELLE	SCHEIBE

contact@emc-motoculture.com

F72

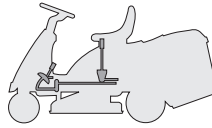
F72 hydro

COMANDO TRASMISSIONE E FRENO
DRIVE AND BRAKE CONTROLS
COMMANDE TRANSMISSION ET FREIN
GETRIEBE UND BREMSE ANTRIEB

2000

004Y.0

1 / 2

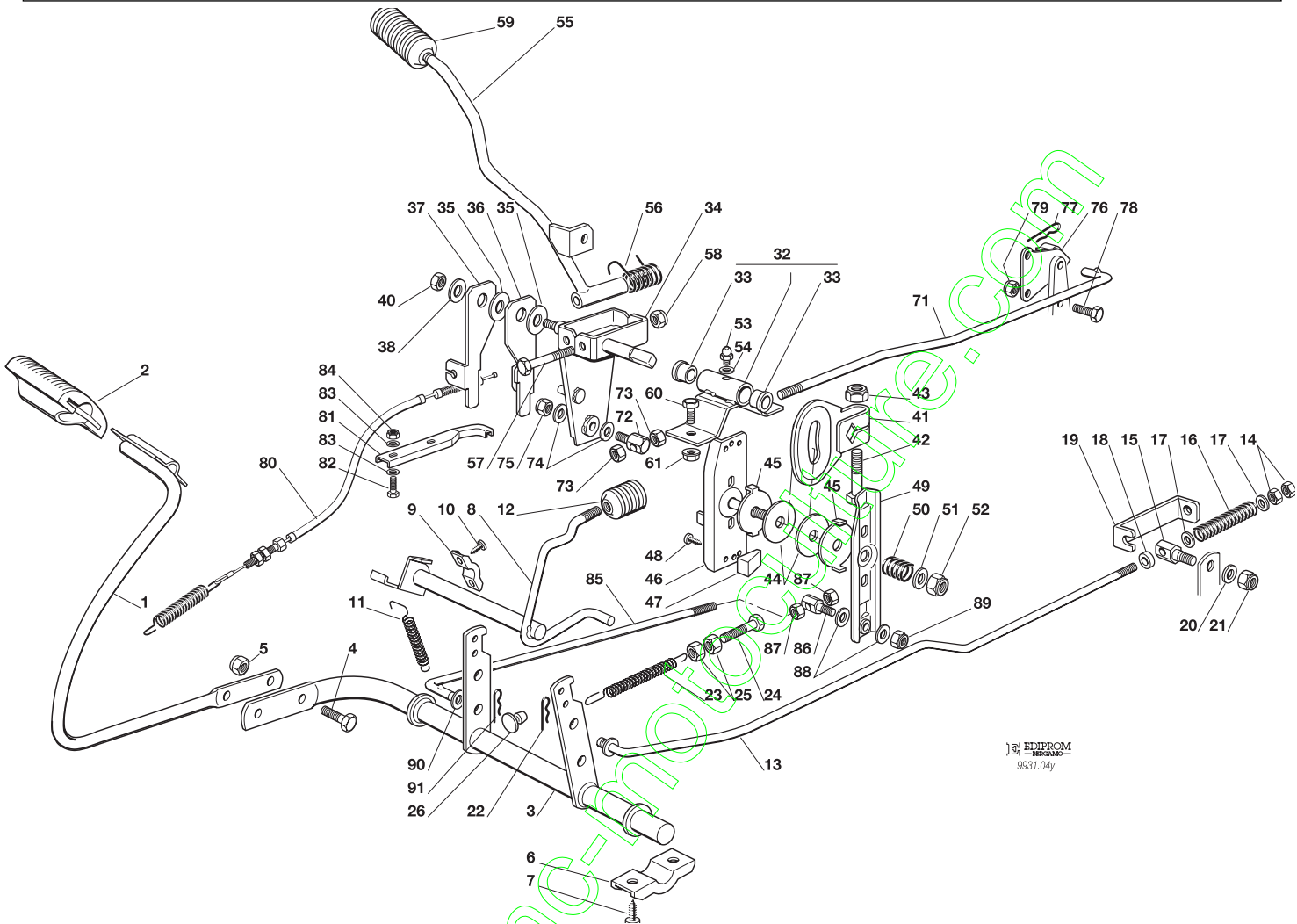

EDIPROM
9931.04y

N.	CODE	Q.TY	DESCRIZIONE	DESCRIPTION	DESCRIPTION	BESCHREIBUNG
1	84503001/0	1	PEDALE	PEDAL	PEDAL	PEDAL
2	25110267/0	1	COPRISTAFFA	CLAMP COVER	COUVRE ETRIER	BRIDEDECKEL
3	84001015/1	1	ASSE FRENO	AXLE	AXE	ACHSE
4	12793301/0	2	VITE	SCREW	VIS	SCHRAUBE
5	12155000/0	2	DADO	NUT	ECROU	MUTTER
6	27546015/0	2	PIASTRINA	PLATE	PLAQUE	PLATTE
7	12731350/0	4	VITE	SCREW	VIS	SCHRAUBE
8	84001011/2	1	ASSE FRENO STAZIONAM.	AXLE	AXE	ACHSE
9	25547049/0	2	PIASTRINA	PLATE	PLAQUE	PLATTE
10	12731601/0	4	VITE	SCREW	VIS	SCHRAUBE
11	27430552/0	1	MOLLA	SPRING	RESSORT	FEDER
12	27395050/0	1	MANOPOLA	KNOB	POIGNEE	KNOPF
13	27034060/0	1	ASTA	ROD	BARRE	STANGE
14	12293200/0	2	DADO	NUT	ECROU	MUTTER
15	27510103/0	1	PERNO	PIN	PIVOT	BOLZEN
16	25430236/0	1	MOLLA	SPRING	RESSORT	FEDER
17	12521350/0	2	ROSETTA	WASHER	RONDELLE	SCHEIBE
18	22171001/0	1	DISTANZIALE	SPACER	ENTRETOISE	ENTFERNUNGSSTÜCK
19	25774275/0	1	STAFFA	CLAMP	ETRIER	BRIDE
20	12523050/0	1	ROSETTA	WASHER	RONDELLE	SCHEIBE
21	12154510/0	1	DADO	NUT	ECROU	MUTTER
22	24487997/0	1	COPPIGLIA	COTTER PIN	GOUPILLE	SPLIT
23	25430220/0	1	MOLLA	SPRING	RESSORT	FEDER
24	22943005/0	1	VITE	SCREW	VIS	SCHRAUBE
25	12293200/0	2	DADO	NUT	ECROU	MUTTER
26	27275000/0	1	GOMMINO	GROMMET	CAOUTCHOUC	GUMMI
32	84773568/0	1	STAFFA CON BUSSOLE	BRACKET WITH BUSSH	INGSETRIER AVEC DOUILLES	BRIDE MIT LAGERN
33	27045080/0	2	BUSSOLA	BUSHING	DOUILLE	LAGER
34	84773561/0	1	LEVA	LEVER	LEVIER	HEBEL





N.	CODE	Q.TY	DESCRIZIONE	DESCRIPTION	DESCRIPTION	BESCHREIBUNG
35	22672151/0	2	RONDELLA	WASHER	RONDELLE	SCHEIBE
36	27772101/0	1	STAFFA	CLAMP	ETRIER	BRIDE
37	27772103/0	1	STAFFA	CLAMP	ETRIER	BRIDE
38	25670011/0	1	RONDELLA	WASHER	RONDELLE	SCHEIBE
40	12155010/0	1	DADO	NUT	ECROU	MUTTER
41	27734055/0	1	SETTORE	SECTOR	SECTEUR	SEKTOR
42	12794900/0	1	VITE	SCREW	VIS	SCHRAUBE
43	12155020/0	1	DADO	NUT	ECROU	MUTTER
44	27158000/0	2	DISCO	PLATE	DISQUE	SCHEIBE
45	27670053/0	2	RONDELLA	WASHER	RONDELLE	SCHEIBE
46	84773565/0	1	STAFFA	CLAMP	ETRIER	BRIDE
47	27063020/0	2	CAMMA	CAM	CAME	NOCKEN
48	12735110/0	2	VITE	SCREW	VIS	SCHRAUBE
49	84773563/0	1	LEVA	LEVER	LEVIER	HEBEL
50	27430560/0	1	MOLLA	SPRING	RESSORT	FEDER
51	25670008/0	1	RONDELLA	WASHER	RONDELLE	SCHEIBE
52	12155020/0	1	DADO	NUT	ECROU	MUTTER
53	12379511/0	1	INGRASSATORE	GREASE DISPENSER	GRAISSEUR	FETTBUCHSE
54	12521330/0	1	RONDELLA	WASHER	RONDELLE	SCHEIBE
55	84317051/1	1	LEVA	GEARSHIFT	LEVIER	HEBEL
56	25430226/0	1	MOLLA	SPRING	RESSORT	FEDER
57	12692050/0	1	VITE	SCREW	VIS	SCHRAUBE
58	12155000/0	1	DADO	NUT	ECROU	MUTTER
59	25394503/1	1	MANOPOLA	KNOB	POIGNEE	WECHSEL
60	12793301/0	1	VITE	SCREW	VIS	SCHRAUBE
61	12293201/0	1	DADO	NUT	ECROU	MUTTER
71	27034057/0	1	ASTA	ROD	BARRE	STANGE
72	25510040/1	1	PERNO	PIN	PIVOT	BOLZEN
73	12293200/0	2	DADO	NUT	ECROU	MUTTER
74	22680007/0	2	RONDELLA	WASHER	RONDELLE	SCHEIBE
75	12155010/0	1	DADO	NUT	ECROU	MUTTER
76	84773567/0	1	STAFFA	CLAMP	ETRIER	BRIDE
77	24487998/0	1	COPPIGLIA	COTTER PIN	GOUPILLE	SPLIT
78	12791400/0	1	VITE	SCREW	VIS	SCHRAUBE
79	12154510/0	1	DADO	NUT	ECROU	MUTTER
80	84207101/0	1	FILO	WIRE	FIL	KABEL
81	27772105/0	1	STAFFA	CLAMP	ETRIER	BRIDE
82	12791400/0	2	VITE	SCREW	VIS	SCHRAUBE
83	12521330/0	4	RONDELLA	WASHER	RONDELLE	SCHEIBE
84	12154510/0	2	DADO	NUT	ECROU	MUTTER
85	27034058/0	1	ASTA	ROD	BARRE	STANGE
86	25510040/1	1	PERNO	PIN	PIVOT	BOLZEN
87	12293200/0	2	DADO	NUT	ECROU	MUTTER
88	25670011/0	2	RONDELLA	WASHER	RONDELLE	SCHEIBE
89	12155010/0	1	DADO	NUT	ECROU	MUTTER
90	12521350/0	1	RONDELLA	WASHER	RONDELLE	SCHEIBE
91	24487998/0	1	COPPIGLIA	COTTER PIN	GOUPILLE	SPLIT

contact@emc-motoculture.com

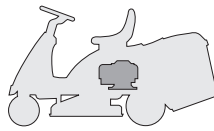
F72**F72 hydro**

MOTORE
ENGINE
MOTEUR
MOTOR
10,5 HP B&S

2000

005.0

1 / 1

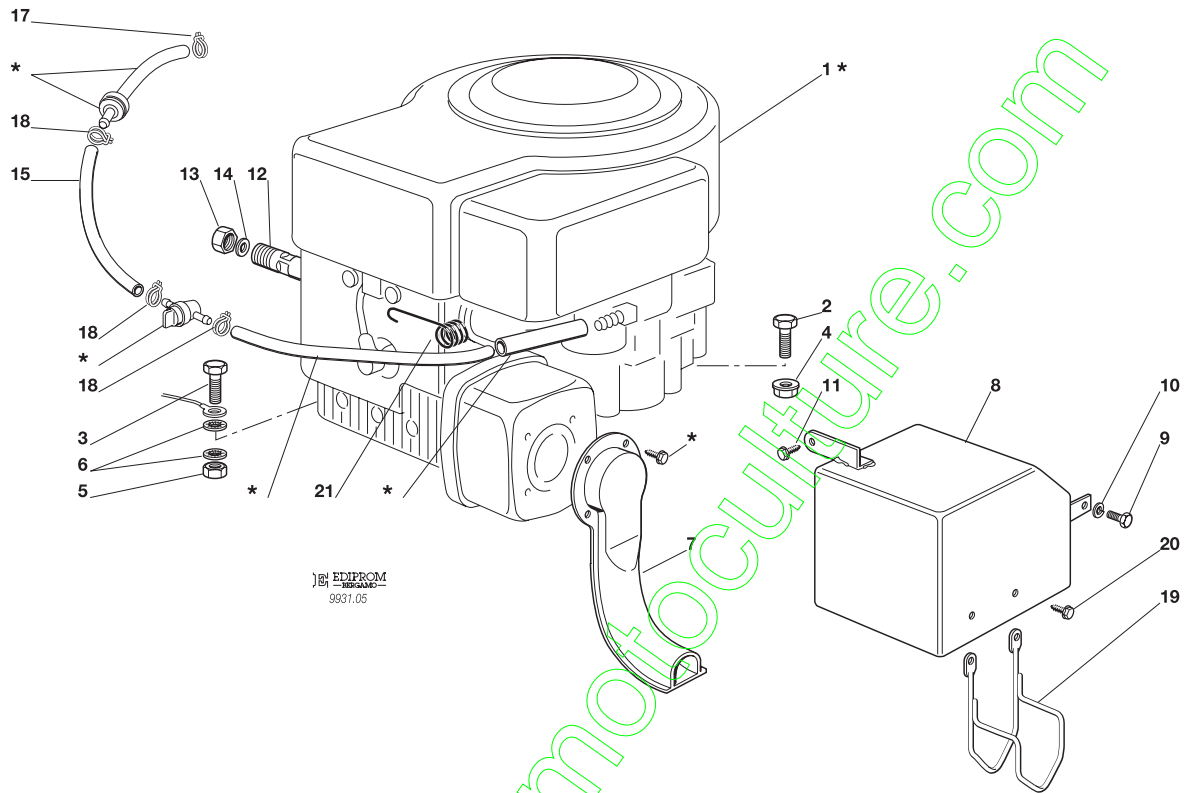

EDIPROM
 9931.05

N.	CODE	Q.TY	DESCRIZIONE	DESCRIPTION	DESCRIPTION	BESCHREIBUNG
1*	-	1	MOTORE	ENGINE	MOTEUR	MOTOR
2	12793701/0	3	VITE	SCREW	VIS	SCHRAUBE
3	12691100/0	1	VITE	SCREW	VIS	SCHRAUBE
4	12293201/0	3	DADO	NUT	ECROU	MUTTER
5	12293200/0	1	DADO	NUT	ECROU	MUTTER
6	12540260/0	2	RONDELLA	WASHER	RONDELLE	SCHIEBE
7	84640550/0	1	RACCORDO SCARICO	EXHAUST CONNECTION	CONNEXION ECHAPPEMENT	AUSPUFFANSCHLUSS
8	82598001/0	1	PROTEZIONE SILENZIATORE	MUFFLER PROTECTION	PROTECTION SILENCIEUX	AUSPUFFSCHUTZ
9	12735510/0	1	VITE	SCREW	VIS	SCHRAUBE
10	12582100/0	1	GROWER	GROWER	GROWER	GROWER
11	12735104/0	1	VITE	SCREW	VIS	SCHRAUBE
12	27598060/0	1	PROLUNGA SCARICO OLIO	OIL DISCHARGE EXTENSION	EXTENSION RALLONGE DE DECH. HUILE	ÖL ENTLEERUNGSVERLÄN- GERUNG
13	18737849/0	1	TAPPO PER PROLUNGA	OIL CAP	BOUCHON HUILE	OELVERSCHLUSS
14	18401001/0	1	GUARNIZIONE	OIL SEAL	GARNITURE	DICHTUNG
15	25869004/0	1	TUBO FILTRO	TUBE	TUBE	ROHR
17	18375053/0	1	FASCETTA	FAIR LED	FIXATION DE CABLE	KABELBEFESTIGUNG
18	18375051/1	3	FASCETTA	FAIR LED	FIXATION DE CABLE	KABELBEFESTIGUNG
19	27600059/1	1	PROTEZIONE SCARICO	EXHAUST PROTECTION	PROTECTION ECHAPPEMENT	AUSPUFFSCHUTZ
20	12735110/0	2	VITE	SCREW	VIS	SCHRAUBE
21	27430562/0	1	MOLLA	SPRING	RESSORT	FEDER

PER LA SOSTITUZIONE DELLE PARTI CONTRASSEGNALE CON «*» RIVOLGERSI AL SERVIZIO ASSISTENZA DEL COSTRUTTORE DEL MOTORE.
 TO REPLACE THE PARTS MARKED «*» SEEK ASSISTANCE FROM THE ENGINE MANUFACTURER'S AFTER SALES SERVICE.
 POUR LE REMPLACEMENT DES PIÈCES MARQUÉES AVEC «*» S'ADRESSER AU SERVICE APRÈS VENTES DU CONSTRUCTEUR DU MOTORE.
 ZUM AUSTAUSCH DER MIT «*» GEKENNZEICHNETEN TEILE, WENDEN SIE SICH AN DEN KUNDENDIENST DES HERSTELLERS DES MOTOR.

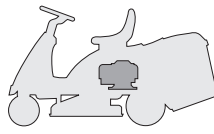
F72**F72 hydro**
MOTORE
ENGINE
MOTEUR
MOTOR
8,5 HP B&S

2000

005a.0

1 / 1

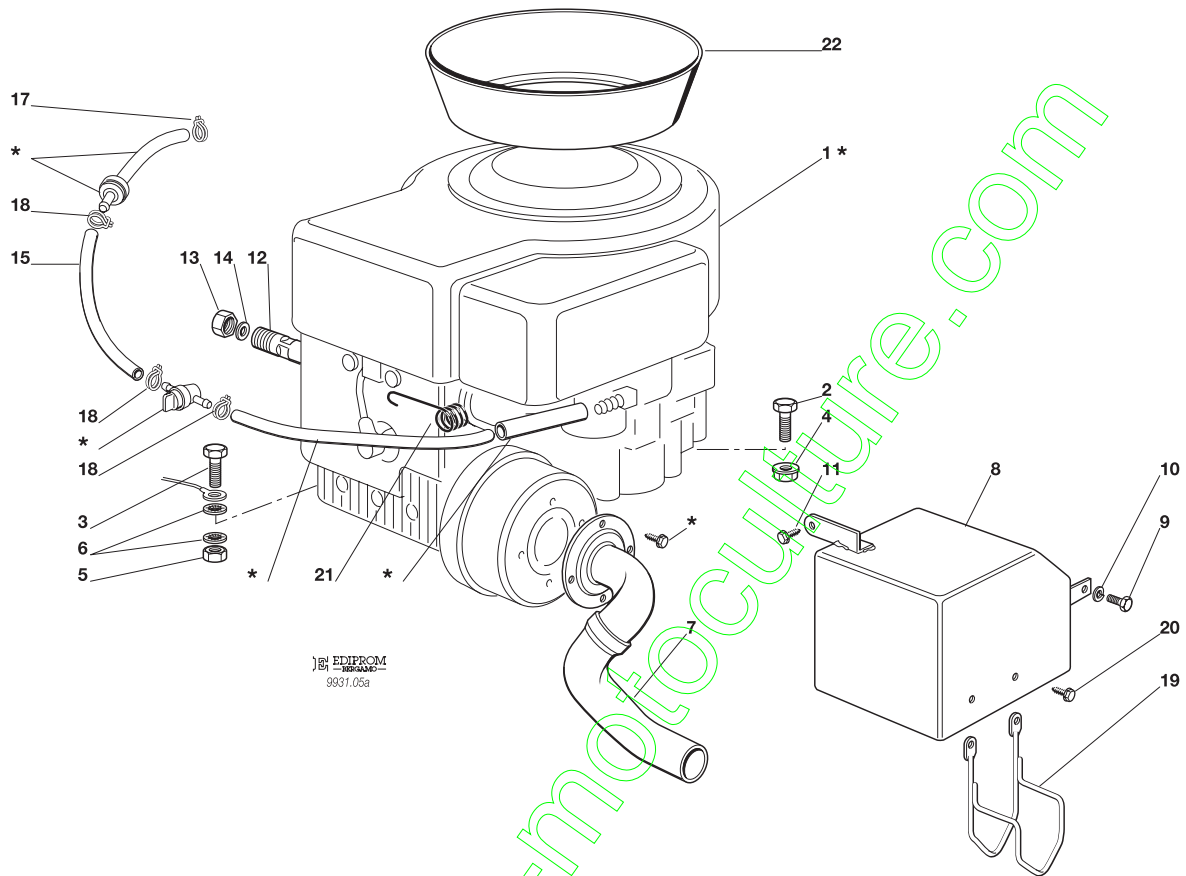
 EDIPROM
 9931.05a

N.	CODE	Q.TY	DESCRIZIONE	DESCRIPTION	DESCRIPTION	BESCHREIBUNG
1*	-	1	MOTORE	ENGINE	MOTEUR	MOTOR
2	12793701/0	3	VITE	SCREW	VIS	SCHRAUBE
3	12691100/0	1	VITE	SCREW	VIS	SCHRAUBE
4	12293201/0	3	DADO	NUT	ECROU	MUTTER
5	12293200/0	1	DADO	NUT	ECROU	MUTTER
6	12540260/0	2	RONDELLA	WASHER	RONDELLE	SCHIBE
7	18738217/0	1	RACCORDO SCARICO	EXHAUST CONNECTION	CONNEXION ECHAPPEMENT	AUSPUFFANSCHLUSS
8	84598053/0	1	PROTEZIONE SILENZIATORE	MUFFLER PROTECTION	PROTECTION SILENCIEUX	AUSPUFFSCHUTZ
9	12735510/0	1	VITE	SCREW	VIS	SCHRAUBE
10	12582100/0	1	GROWER	GROWER	GROWER	GROWER
11	12735104/0	1	VITE	SCREW	VIS	SCHRAUBE
12	27598060/0	1	PROLUNGA SCARICO OLIO	OIL DISCHARGE EXTENSION	EXTENSION RALLONGE DE DECH. HUILE	ÖL ENTLEERUNGSVERLAEN- GERUNG
13	18737849/0	1	TAPPO PER PROLUNGA	OIL CAP	BOUCHON HUILE	OELVERSCHLUSS
14	18401001/0	1	GUARNIZIONE	OIL SEAL	GARNITURE	DICHTUNG
15	25869004/0	1	TUBO FILTRO	TUBE	TUBE	ROHR
17	18375053/0	1	FASCETTA	FAIR LED	FIXATION DE CABLE	KABELBEFESTIGUNG
18	18375051/1	3	FASCETTA	FAIR LED	FIXATION DE CABLE	KABELBEFESTIGUNG
19	27600059/1	1	PROTEZIONE SCARICO	EXHAUST PROTECTION	PROTECTION ECHAPPEMENT	AUSPUFFSCHUTZ
20	12735110/0	2	VITE	SCREW	VIS	SCHRAUBE
21	27430562/0	1	MOLLA	SPRING	RESSORT	FEDER
22	25108007/0	1	CONVOGLIATORE	CONVEYOR	CONVOYEUR	LUFTHAUBE

PER LA SOSTITUZIONE DELLE PARTI CONTRASSEGNALE CON «*» RIVOLGERSI AL SERVIZIO ASSISTENZA DEL COSTRUTTORE DEL MOTORE.
 TO REPLACE THE PARTS MARKED «*» SEEK ASSISTANCE FROM THE ENGINE MANUFACTURER'S AFTER SALES SERVICE.
 POUR LE REMPLACEMENT DES PIÈCES MARQUÉES AVEC «*» S'ADRESSER AU SERVICE APRÈS VENTES DU CONSTRUCTEUR DU MOTEUR.
 ZUM AUSTAUSCH DER MIT «*» GEKENNZEICHNETEN TEILE, WENDEN SIE SICH AN DEN KUNDENDIENST DES HERSTELLERS DES MOTOR.

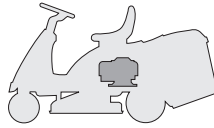
F72**F72 hydro**

MOTORE
ENGINE
MOTEUR
MOTOR
10 HP TECUMSEH

2000

005b.0

1 / 2

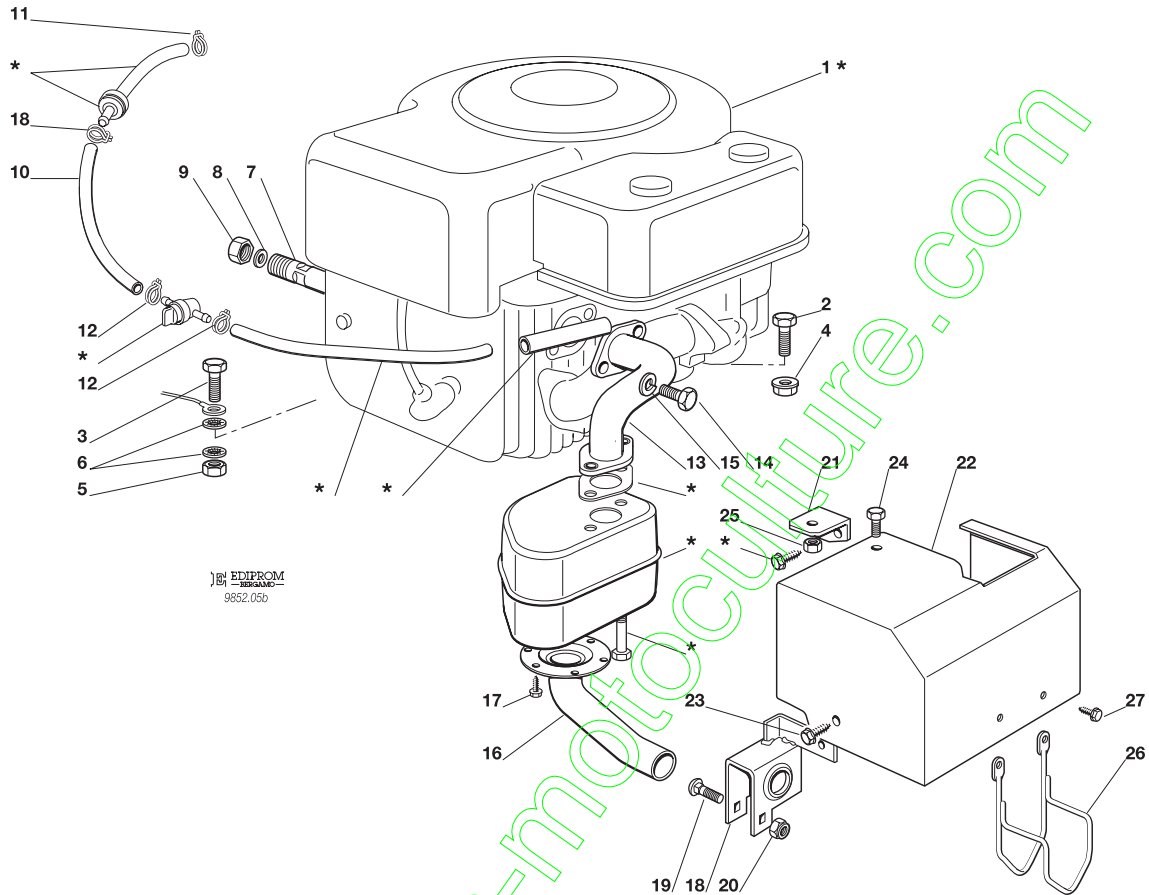

EDIPROM
 9852.05b

N.	CODE	Q.TY	DESCRIZIONE	DESCRIPTION	DESCRIPTION	BESCHREIBUNG
1*	-	1	MOTORE	ENGINE	MOTEUR	MOTOR
2	12793701/0	3	VITE	SCREW	VIS	SCHRAUBE
3	12691100/0	1	VITE	SCREW	VIS	SCHRAUBE
4	12293201/0	3	DADO	NUT	ECROU	MUTTER
5	12293200/0	1	DADO	NUT	ECROU	MUTTER
6	12540260/0	2	RONDELLA	WASHER	RONDELLE	SCHLEIBE
7	27598060/0	1	PROLUNGA SCARICO OLIO	OIL DISCHARGE EXTENSION	EXTENSION RALLONGE DE DECH. HUILE	ÖL ENTLEERUNGSVERLÄN- GERUNG
8	18737849/0	1	TAPPO PER PROLUNGA	OIL CAP	BOUCHON HUILE	OELVERSCHLUSS
9	18401001/0	1	GUARNIZIONE	OIL SEAL	GARNITURE	DICHTUNG
10	25869004/0	1	TUBO FILTRO	TUBE	TUBE	ROHR
11	18375053/0	1	FASCETTA	FAIR LED	FIXATION DE CABLE	KABELBEFESTIGUNG
12	18375051/1	3	FASCETTA	FAIR LED	FIXATION DE CABLE	KABELBEFESTIGUNG
13	18738218/0	1	TUBI RACCORDO SCARICO	EXHAUST CONNECTING TUBE	TUBE DE CONNEXION POUR ECHAPPEMENT	VERBINDUNGSRÖHR FÜR ABGASUNG
14	12737450/0	2	VITE	SCREW	VIS	SCHRAUBE
15	12583500/0	2	GROWER	GROWER	GROWER	SCHRAUBE
16	18738216/0	1	TUBI RACCORDO SCARICO	EXHAUST CONNECTING TUBE	TUBE DE CONNEXION POUR ECHAPPEMENT	VERBINDUNGSRÖHR FÜR ABGASUNG
17	12735106/0	4	VITE	SCREW	VIS	SCHRAUBE
18	84773557/0	1	STAFFA	BRACKET	ETRIER	BRIDE
19	12815240/0	1	VITE	SCREW	VIS	SCHRAUBE
20	12154510/0	1	DADO	NUT	ECROU	MUTTER
21	27546009/0	1	PIASTRINA	PLATE	PLAQUETTE	PLATTE
22	84598061/0	1	PROTEZIONE SILENZIATORE	MUFFLER PROTECTION	PROTECTION SILENCIEUX	AUSPUFFSCHUTZ
23	12731601/0	1	VITE	SCREW	VIS	SCHRAUBE
24	12790780/0	1	VITE	SCREW	VIS	SCHRAUBE
25	12292102/0	1	DADO	NUT	ECROU	MUTTER
26	27600059/1	1	PROTEZIONE SCARICO	EXHAUST PROTECTION	PROTECTION ECHAPPEMENT	AUSPUFFSCHUTZ
27	12735110/0	2	VITE	SCREW	VIS	SCHRAUBE



N.	CODE	Q.TY	DESCRIZIONE	DESCRIPTION	DESCRIPTION	BESCHREIBUNG
----	------	------	-------------	-------------	-------------	--------------

PER LA SOSTITUZIONE DELLE PARTI CONTRASSEGNAE CON «★» RIVOLGERSI AL SERVIZIO ASSISTENZA DEL COSTRUTTORE DEL MOTORE.
TO REPLACE THE PARTS MARKED «★» SEEK ASSISTANCE FROM THE ENGINE MANUFACTURER'S AFTER SALES SERVICE.
POUR LE REMPLACEMENT DES PIÈCES MARQUÉES AVEC «★» S'ADRESSER AU SERVICE APRÈS VENTES DU CONSTRUCTEUR DU MOTEUR.
ZUM AUSTAUSCH DER MIT «★» GEKENNZEICHNETEN TEILE, WENDEN SIE SICH AN DEN KUNDENDIENST DES HERSTELLERS DES MOTOR.

contact@enc-motoculture.com

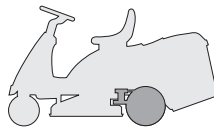
F72*F72 hydro*
TRASMISSIONE
TRANSMISSION
TRANSMISSION
GETRIEBE

2000

006M.0

1 / 2

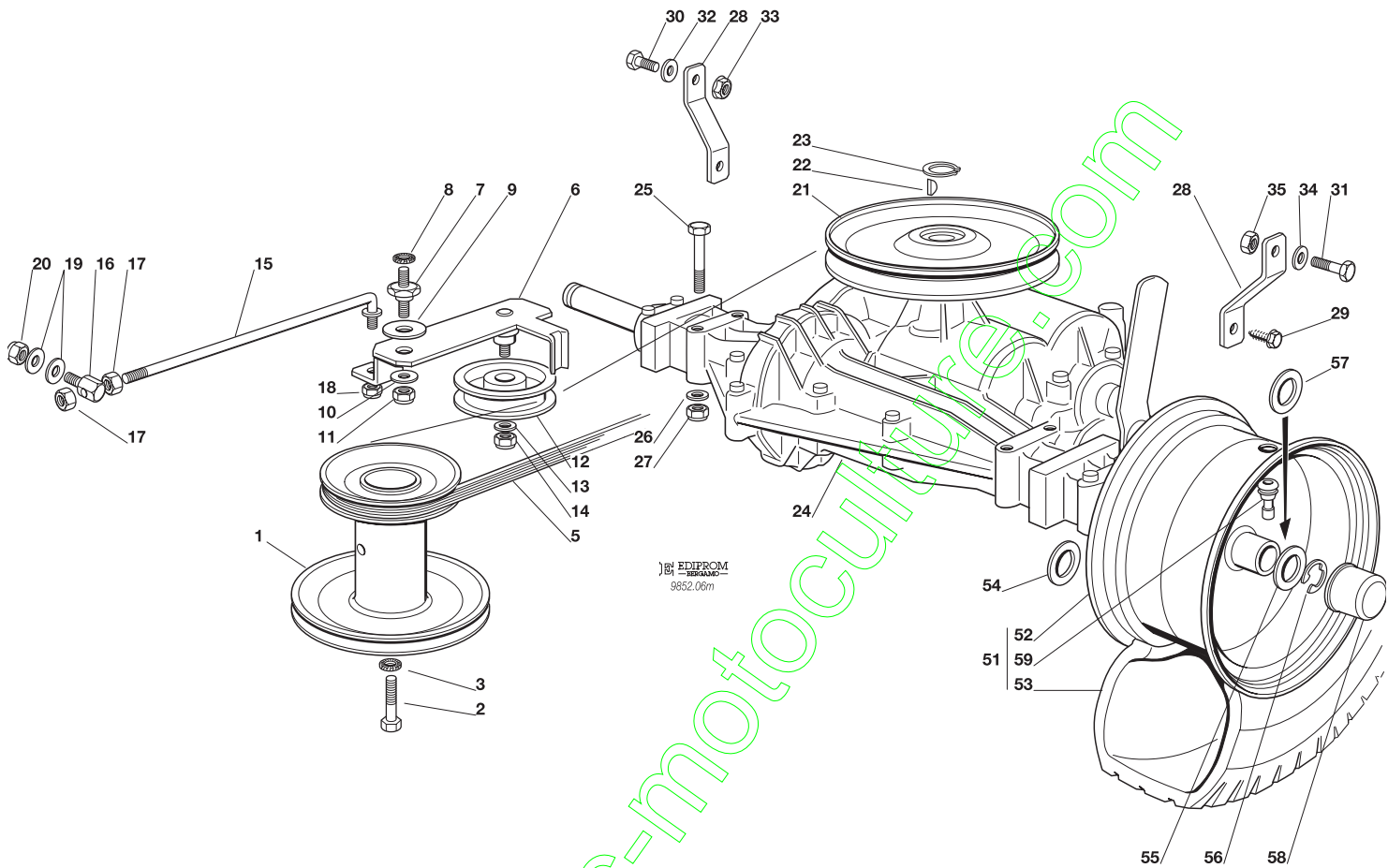

N.	CODE	Q.TY	DESCRIZIONE	DESCRIPTION	DESCRIPTION	BESCHREIBUNG
1	27604003/1	1	PULEGGIA	PULLEY	POULIE	RIEMENSCHLEIBE
2	12737310/0	1	VITE	SCREW	VIS	SCHRAUBE
3	12543000/0	1	ROSETTA	WASHER	RONDELLE	SCHLEIBE
5	35061400/0	1	CINGHIA	BELT	COURROIE	RIEMEN
6	84317055/0	1	LEVA	LEVER	LEVIER	HEBEL
7	27510096/0	1	PERNO	PIN	PIVOT	BOLZEN
8	12540260/0	1	RONDELLA	WASHER	RONDELLE	SCHLEIBE
9	22672151/0	1	RONDELLA	WASHER	RONDELLE	SCHLEIBE
10	25670011/0	1	RONDELLA	WASHER	RONDELLE	SCHLEIBE
11	12155010/0	1	DADO	NUT	ECROU	MUTTER
12	25601554/0	1	PULEGGIA	PULLEY	POULIE	RIEMENSCHLEIBE
13	12523060/0	1	RONDELLA	WASHER	RONDELLE	SCHLEIBE
14	12155000/0	2	DADO	NUT	ECROU	MUTTER
15	27034054/0	1	TIRANTE	TIE ROD	TIRANT	SPANNSTANGE
16	25510040/1	1	PERNO	PIN	PIVOT	BOLZEN
17	12293200/0	2	DADO	NUT	ECROU	MUTTER
18	12155000/0	1	DADO	NUT	ECROU	MUTTER
19	25670011/0	2	RONDELLA	WASHER	RONDELLE	SCHLEIBE
20	12155000/0	2	DADO	NUT	ECROU	MUTTER
21	82601503/0	1	PULEGGIA	PULLEY	POULIE	RIEMENSCHLEIBE
22	12139430/0	1	LINGUETTA	KEY	CLAVETTE	KEIL
23	12608950/0	1	ANELLO ELASTICO	SNAP RING	ANNEAU RESSORT	SPRENGRING
24★	18400915/1	1	ASSE POSTERIORE	REAR AXLE	AXE ARRIERE	HINTERACHSE
25	12691800/0	4	VITE	SCREW	VIS	SCHRAUBE
26	12521350/0	4	RONDELLA	WASHER	RONDELLE	SCHLEIBE
27	12155000/0	4	DADO	NUT	ECROU	MUTTER
28	27772067/0	2	STAFFA	CLAMP	ETRIER	BRIDE
29	12735150/0	2	VITE	SCREW	VIS	SCHRAUBE
30	12793102/0	1	VITE	SCREW	VIS	SCHRAUBE
31	12793301/0	1	VITE	SCREW	VIS	SCHRAUBE
32	12523060/0	1	RONDELLA	WASHER	RONDELLE	SCHLEIBE





N.	CODE	Q.TY	DESCRIZIONE	DESCRIPTION	DESCRIPTION	BESCHREIBUNG
33	12293201/0	1	DADO	NUT	ECROU	MUTTER
34	12521350/0	1	RONDELLA	WASHER	RONDELLE	SCHEIBE
35	12155000/0	1	DADO	NUT	ECROU	MUTTER
51	☛	2	RUOTA POSTERIORE	REAR WHEEL	ROUE ARRIERE	HINTERRAD
	84680050/0		TURF SAVER CARLISLE	TURF SAVER CARLISLE	TURF SAVER CARLISLE	TURF SAVER CARLISLE
	84680053/0		DELI TIRE	DELI TIRE	DELI TIRE	DELI TIRE
52	84044001/0	1	CERCHIO RUOTA	RIMM	BANDAGE ROUE	HINTERRAD FELGER
53	☛	1	PNEUMATICO	SHOE	PNEU	REIFEN
	27590051/0		TURF SAVER CARLISLE	TURF SAVER CARLISLE	TURF SAVER CARLISLE	TURF SAVER CARLISLE
	27590053/0		DELI TIRE	DELI TIRE	DELI TIRE	DELI TIRE
54	12521410/0	2	RONDELLA	WASHER	RONDELLE	SCHEIBE
55	25670005/1	2	RONDELLA	WASHER	RONDELLE	SCHEIBE
56	12001010/0	2	ANELLO ELASTICO	SNAP RING	ANNEAU RESSORT	SPRENGRING
57	12520010/0	0-4	ROSETTA	WASHER	RONDELLE	SCHEIBE
58	22110230/0	2	COPRIMOZZO	HUB COVER	COUVRE MOYEU	NABEDECKEL
59	25950000/0	2	VALVOLA	VALVE	SOUPAPE	VENTIL

PER LA SOSTITUZIONE IN GARANZIA DELLE PARTI CONTRASSEGNAE CON «☛» RIVOLGERSI AL SERVIZIO ASSISTENZA DEL COSTRUTTORE (TECUMSEH).

TO REPLACE UNDER GUARANTEE THE PARTS MARKED «☛» SEEK ASSISTANCE FROM MANUFACTURER'S AFTER SALES SERVICE (TECUMSEH).

POUR LE REMPLACEMENT, SOUS GARANTIE DES PIÈCES MARQUÉES AVEC «☛» S'ADRESSER AU SERVICE APRÈS VENTES DU CONSTRUCTEUR (TECUMSEH).

ZUM AUSTAUSCH DER MIT «☛» GEKENNZEICHNETEN TEILE IM RAHMEN DER GARANTIE, WENDEN SIE SICH AN DEN KUNDENDIENST DES HERSTELLERS (TECUMSEH).

contact@emc-motoculture.com

F72

F72 hydro

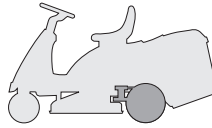

**TRASMISSIONE
TRANSMISSION
TRANSMISSION
GETRIEBE**

2000

006Y.0

1 / 2

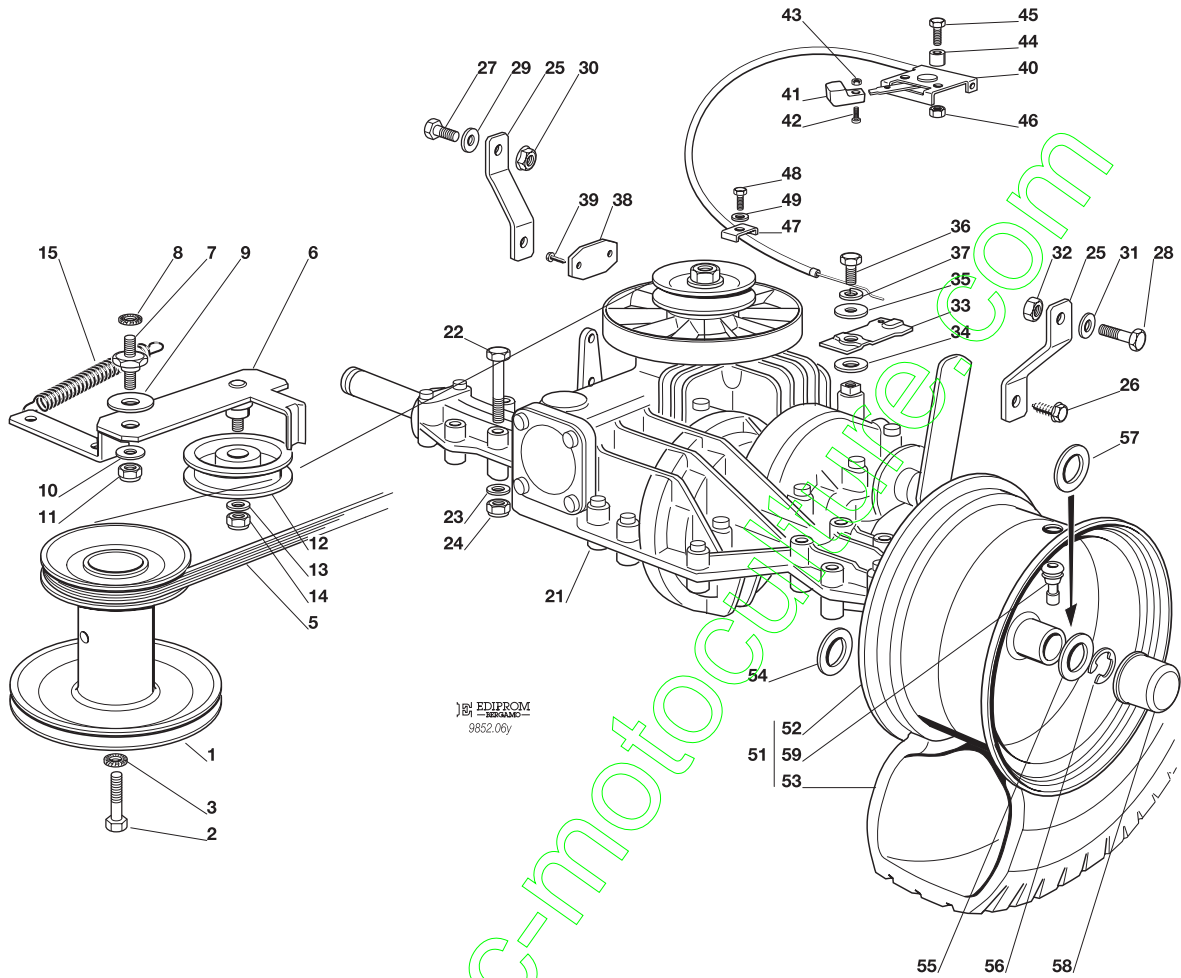

N.	CODE	Q.TY	DESCRIZIONE	DESCRIPTION	DESCRIPTION	BESCHREIBUNG
1	27604005/0	1	PULEGGIA	PULLEY	POULIE	RIEMENSCHLEIBE
2	12737310/0	1	VITE	SCREW	VIS	SCHRAUBE
3	12543000/0	1	ROSETTA	WASHER	RONDELLE	SCHLEIBE
5	35061405/0	1	CINGHIA	BELT	COURROIE	RIEMEN
6	84317067/0	1	LEVA	LEVER	LEVIER	HEBEL
7	27510096/0	1	PERNO	PIN	PIVOT	BOLZEN
8	12540260/0	1	RONDELLA	WASHER	RONDELLE	SCHLEIBE
9	22672151/0	1	RONDELLA	WASHER	RONDELLE	SCHLEIBE
10	25670011/0	1	RONDELLA	WASHER	RONDELLE	SCHLEIBE
11	12155010/0	1	DADO	NUT	ECROU	MUTTER
12	25601554/0	1	PULEGGIA	PULLEY	POULIE	RIEMENSCHLEIBE
13	12523060/0	1	RONDELLA	WASHER	RONDELLE	SCHLEIBE
14	12155000/0	2	DADO	NUT	ECROU	MUTTER
15	22446402/0	1	MOLLA	SPRING	RESSORT	FEDER
21★	18400930/1	1	ASSE POSTERIORE	REAR AXLE	AXE ARRIERE	HINTERACHSE
22	12691800/0	4	VITE	SCREW	VIS	SCHRAUBE
23	12521350/0	4	RONDELLA	WASHER	RONDELLE	SCHLEIBE
24	12155000/0	4	DADO	NUT	ECROU	MUTTER
25	27772067/0	2	STAFFA	CLAMP	ETRIER	BRIDE
26	12735150/0	2	VITE	SCREW	VIS	SCHRAUBE
27	12793102/0	1	VITE	SCREW	VIS	SCHRAUBE
28	12793301/0	1	VITE	SCREW	VIS	SCHRAUBE
29	12523060/0	1	RONDELLA	WASHER	RONDELLE	SCHLEIBE
30	12293201/0	1	DADO	NUT	ECROU	MUTTER
31	12521350/0	1	RONDELLA	WASHER	RONDELLE	SCHLEIBE
32	12155000/0	1	DADO	NUT	ECROU	MUTTER
33	27315089/0	1	LEVA	LEVER	LEVIER	HEBEL
34	12521370/0	1	RONDELLA	WASHER	RONDELLE	SCHLEIBE
35	12523050/0	1	RONDELLA	WASHER	RONDELLE	SCHLEIBE





N.	CODE	Q.TY	DESCRIZIONE	DESCRIPTION	DESCRIPTION	BESCHREIBUNG
36	12735520/0	1	VITE	SCREW	VIS	SCHRAUBE
37	12582100/0	1	GROWER	GROWER	GROWER	GROWER
38	27546019/0	1	PIATSRINA	PLATE	PLAQUETTE	PLATTE
39	12735140/0	2	VITE	SCREW	VIS	SCHRAUBE
40	81007092/0	1	COMANDO SBLOCCO	DISENGAGE CONTROL	COMMANDE DEBLOCAGE	ENTSPERREN HEBEL
41	22399801/0	1	MANOPOLINA	HANDLE	POIGNEE	GRIFF
42	12726288/0	1	VITE	SCREW	VIS	SCHRAUBE
43	12290800/0	1	DADO	NUT	ECROU	MUTTER
44	25160012/0	2	DISTANZIALE	SPACER	ENTRETOISE	ENTFERNUNGSSTÜCK
45	12674550/0	2	VITE	SCREW	VIS	SCHRAUBE
46	12154510/0	2	DADO	NUT	ECROU	MUTTER
47	27546023/0	1	PIASTRINA	PLATE	PLAQUETTE	PLATTE
48	12731601/0	1	VITE	SCREW	VIS	SCHRAUBE
49	12523020/0	1	RONDELLA	WASHER	RONDELLE	SCHEIBE
51	☛	2	RUOTA POSTERIORE	REAR WHEEL	ROUE ARRIERE	HINTERRAD
	84680050/0		TURF SAVER CARLISLE	TURF SAVER CARLISLE	TURF SAVER CARLISLE	TURF SAVER CARLISLE
	84680053/0		DELI TIRE	DELI TIRE	DELI TIRE	DELI TIRE
52	84044001/0	1	CERCHIO RUOTA	RIMM	BANDAGE ROUE	HINTRERRAD FELGER
53	☛	1	PNEUMATICO	SHOE	PNEU	REIFEN
	27590051/0		TURF SAVER CARLISLE	TURF SAVER CARLISLE	TURF SAVER CARLISLE	TURF SAVER CARLISLE
	27590053/0		DELI TIRE	DELI TIRE	DELI TIRE	DELI TIRE
54	12521410/0	2	RONDELLA	WASHER	RONDELLE	SCHEIBE
55	25670005/1	2	RONDELLA	WASHER	RONDELLE	SCHEIBE
56	12001010/0	2	ANELLO ELASTICO	SNAP RING	ANNEAU RESSORT	SPRENGRING
57	12520010/0	0-4	ROSETTA	WASHER	RONDELLE	SCHEIBE
58	22110230/0	2	COPRIMOZZO	HUB COVER	COUVRE MOYEU	NABEDECKEL
59	25950000/0	2	VALVOLA	VALVE	SOUPAPE	VENTIL

PER LA SOSTITUZIONE IN GARANZIA DELLE PARTI CONTRASSEGNALE CON «*» RIVOLGERSI AL SERVIZIO ASSISTENZA DEL COSTRUTTORE (TECUMSEH).

TO REPLACE UNDER GUARANTEE THE PARTS MARKED «*» SEEK ASSISTANCE FROM MANUFACTURER'S AFTER SALES SERVICE (TECUMSEH).

POUR LE REMPLACEMENT, SOUS GARANTIE DES PIÈCES MARQUÉES AVEC «*» S'ADRESSER AU SERVICE APRÈS VENTES DU CONSTRUCTEUR (TECUMSEH).

ZUM AUSTAUSCH DER MIT «*» GEKENNZEICHNETEN TEILE IM RAHMEN DER GARANTIE, WENDEN SIE SICH AN DEN KUNDENDIENST DES HERSTELLERS (TECUMSEH).

contact@emc-mototechnik.com

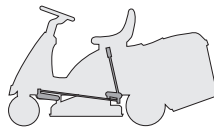
F72**F72 hydro**

SOLLEVAMENTO PIATTO DI TAGLIO
CUTTING PLATE LIFTING
SOULEVEMENT PLATEAU DE COUPE
SCHNEIDWERKZEUG AUFHEBESATZ

2000

007.0

1 / 1

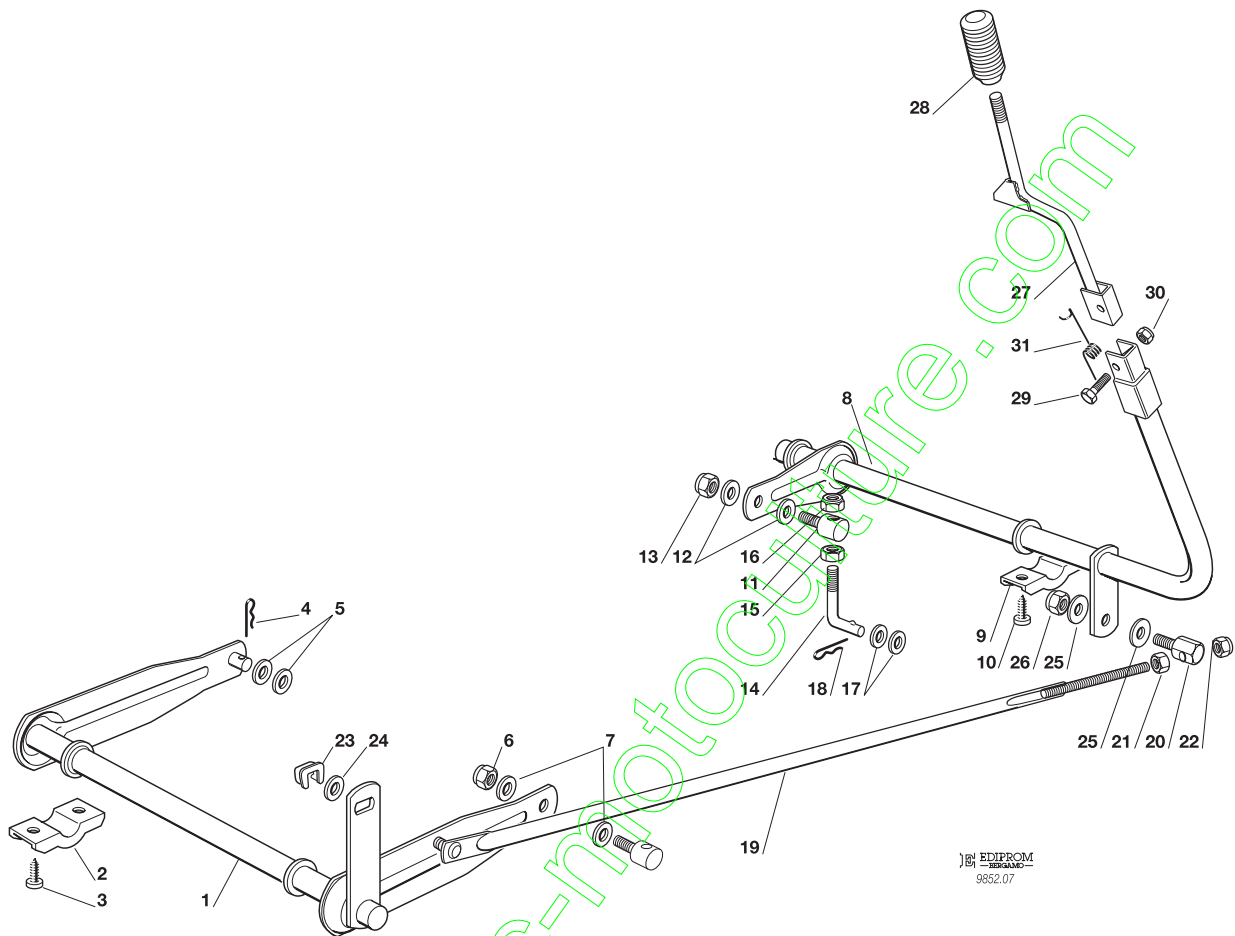

EDIPROM
 9852.07

N.	CODE	Q.TY	DESCRIZIONE	DESCRIPTION	DESCRIPTION	BESCHREIBUNG
1	84001003/0	1	ASSE FULCRO PIATTO	AXLE	AXE	ACHSE
2	27546015/0	2	PIASTRINA	PLATE	PLAQUE	PLATTE
3	12731350/0	4	VITE	SCREW	VIS	SCHRAUBE
4	24487997/0	1	COPPIGLIA	COTTER PIN	GOUPILLE	SPLIT
5	25670008/0	2	RONDELLA	WASHER	RONDELLE	SCHEIBE
6	12156602/0	1	DADO	NUT	ECROU	MUTTER
7	25670008/0	2	RONDELLA	WASHER	RONDELLE	SCHEIBE
8	84001005/1	1	ASSE FULCRO PIATTO	AXLE	AXE	ACHSE
9	27546015/0	2	PIASTRINA	PLATE	PLAQUE	PLATTE
10	12731350/0	4	VITE	SCREW	VIS	SCHRAUBE
11	25510007/1	1	PERNO	PIN	PIVOT	BOLZEN
12	25670008/0	2	RONDELLA	WASHER	RONDELLE	SCHEIBE
13	12156602/0	1	DADO	NUT	ECROU	MUTTER
14	25840003/0	1	TIRANTE	TIE ROD	TIRANT	SPANNSTANGE
15	12295200/0	1	DADO	NUT	ECROU	MUTTER
16	12156602/0	1	DADO	NUT	ECROU	MUTTER
17	25670008/0	2	RONDELLA	WASHER	RONDELLE	SCHEIBE
18	24487997/0	1	COPPIGLIA	COTTER PIN	GOUPILLE	SPLIT
19	84002051/0	1	ASTA COLLEGAMENTO	ROD	TIGE	STAB
20	25510040/1	1	PERNO	PIN	PIVOT	BOLZEN
21	12293200/0	1	DADO	NUT	ECROU	MUTTER
22	12155000/0	1	DADO	NUT	ECROU	MUTTER
23	12436050/0	1	PIASTRINA	PLATE	PLAQUE	PLATTE
24	25670011/0	1	RONDELLA	WASHER	RONDELLE	SCHEIBE
25	25670011/0	2	RONDELLA	WASHER	RONDELLE	SCHEIBE
26	12155000/0	1	DADO	NUT	ECROU	MUTTER
27	84317065/0	1	LEVA SOLLEVAMENTO	LEVER	LEVIER	HEBEL
28	27395052/0	1	MANOPOLA	KNOB	POIGNEE	GRIF
29	12674700/0	1	VITE	SCREW	VIS	SCHRAUBE
30	12154510/0	1	DADO	NUT	ECROU	MUTTER
31	27430555/0	1	MOLLA	SPRING	RESSORT	FEDER

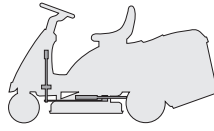
F72**F72 hydro**
PIATTO DI TAGLIO (1)
CUTTING PLATE (1)
PLATEAU DE COUPE (1)
SCHNEIDWERKZEUG (1)

2000

008.0

1 / 2

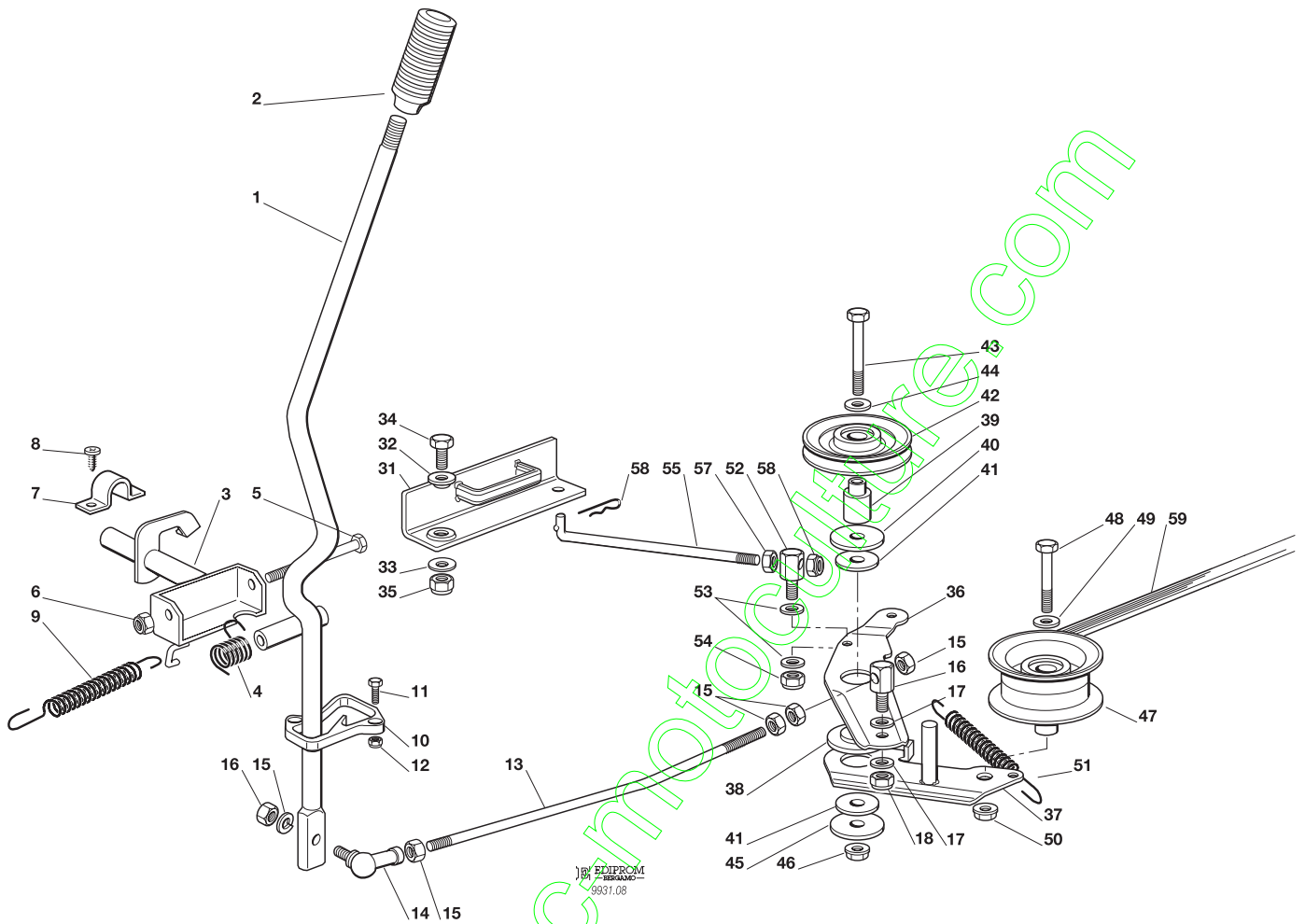

N.	CODE	Q.TY	DESCRIZIONE	DESCRIPTION	DESCRIPTION	BESCHREIBUNG
1	84317059/0	1	LEVA	LEVER	LEVIER	HEBEL
2	27395051/0	1	MANOPOLA	KNOB	POIGNEE	GRIF
3	84001007/0	1	ASSE INNESTO LAMA	AXLE	AXE	ACHSE
4	25430226/0	1	MOLLA	SPRING	RESSORT	FEDER
5	12692050/0	1	VITE	SCREW	VIS	SCHRAUBE
6	12155000/0	1	DADO	NUT	ECROU	MUTTER
7	25547049/0	2	PIASTRINA	PLATE	PLAQUE	PLATTE
8	12731601/0	4	VITE	SCREW	VIS	SCHRAUBE
9	25430220/0	1	MOLLA	SPRING	RESSORT	FEDER
10	27487000/0	1	PATTINO	SHOE	BLOC DE GLISSEMENT	GLEITBLOCK
11	12791200/0	2	VITE	SCREW	VIS	SCHRAUBE
12	12154510/0	2	DADO	NUT	ECROU	MUTTER
13	27034061/0	1	ASTA	ROD	TIGE	STAB
14	22746601/0	1	SNODO	JOINT	JOINT	GELENK
15	12293200/0	4	DADO	NUT	ECROU	MUTTER
16	25510040/1	1	PERNO	PIN	PIVOT	BOLZEN
17	25670011/0	2	RONDELLA	WASHER	RONDELLE	SCHEIBE
18	12155000/0	1	DADO	NUT	ECROU	MUTTER
31	84220501/0	1	FRENO LAMA	BRAKE	FREIN	BREMSE
32	22041980/0	1	BUSSOLA	BUSH	DOUILLE	BÜCHSE
33	22672152/0	1	RONDELLA	WASHER	RONDELLE	SCHEIBE
34	12793102/0	1	VITE	SCREW	VIS	SCHRAUBE
35	12155010/0	1	DADO	NUT	ECROU	MUTTER
36	27315059/0	1	LEVA	LEVER	LEVIER	HEBEL
37	84317061/0	1	LEVA	LEVER	LEVIER	HEBEL
38	27047000/0	1	BUSSOLA	BUSH	DOUILLE	BÜCHSE
39	27160051/0	1	DISTANZIALE	SPACER	ENTRETOISE	ENTFERNUNGSSTÜCK
40	12523070/0	1	RONDELLA	WASHER	RONDELLE	SCHEIBE
41	22672152/0	2	RONDELLA	WASHER	RONDELLE	SCHEIBE



N.	CODE	Q.TY	DESCRIZIONE	DESCRIPTION	DESCRIPTION	BESCHREIBUNG
42	81000772/1	1	PULEGGIA	PULLEY	POULIE	RIEMENSCHLEIBE
43	12692080/0	1	VITE	SCREW	VIS	SCHRAUBE
44	12523060/0	1	ROSETTA	WASHER	RONDELLE	SCHEIBE
45	12523070/0	1	RONDELLA	WASHER	RONDELLE	SCHEIBE
46	12155000/0	1	DADO	NUT	ECROU	MUTTER
47	27604002/0	1	PULEGGIA	PULLEY	POULIE	RIEMENSCHLEIBE
48	12691900/0	1	VITE	SCREW	VIS	SCHRAUBE
49	12523060/0	1	ROSETTA	WASHER	RONDELLE	SCHEIBE
50	12293201/0	1	DADO	NUT	ECROU	MUTTER
51	25430210/0	1	MOLLA	SPRING	RESSORT	FEDER
52	25510040/1	1	PERNO	PIN	PIVOT	BOLZEN
53	25670011/0	2	RONDELLA	WASHER	RONDELLE	SCHEIBE
54	12155000/0	1	DADO	NUT	ECROU	MUTTER
55	27034051/0	1	ASTA	ROD	TIGE	STAB
56	24487997/0	1	COPPGLIA	COTTER PIN	GOUPILLE	SPLIT
57	12293200/0	1	DADO	NUT	ECROU	MUTTER
58	12155000/0	1	DADO	NUT	ECROU	MUTTER
59	35061424/0	1	CINGHIA	BELT	COURROIE	RIEMEN

contact@emc-motoculture.com

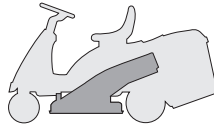
F72**F72 hydro**
PIATTO DI TAGLIO (2)
CUTTING PLATE (2)
PLATEAU DE COUPE (2)
SCHNEIDWERKZEUG (2)

2000

009.0

1 / 2

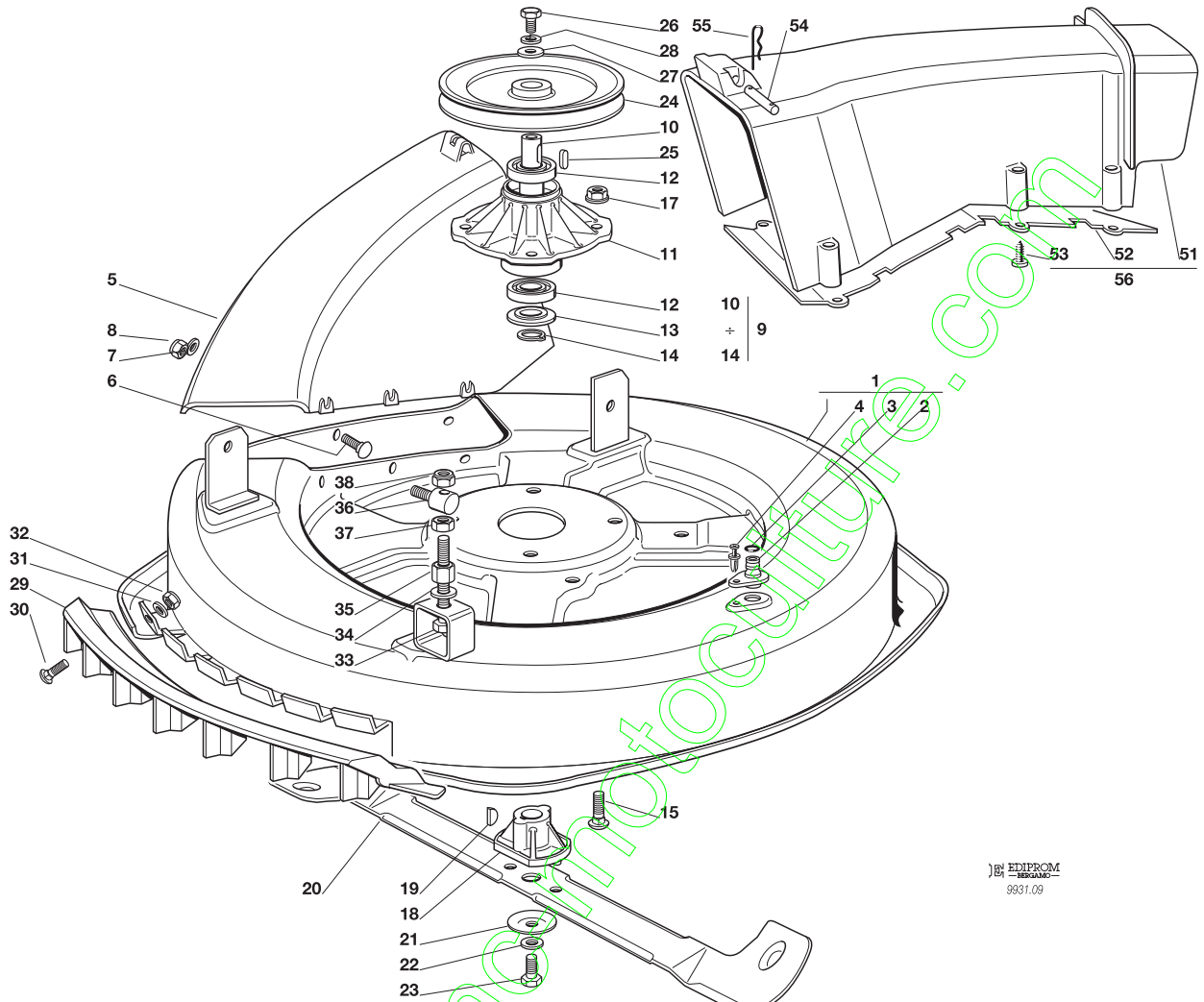
 EDIPROM
 9931.09

N.	CODE	Q.TY	DESCRIZIONE	DESCRIPTION	DESCRIPTION	BESCHREIBUNG
1	84564092/0	1	PIATTO	PLATE	PLATEAU	SCHNEID
2	25033060/0	1	ATTACCO	WATER HOSE CONNECTION	RACCORD TUYAU D'EAU	WASSERANSCHLUSS
3	19035000/0	1	ANELLO OR	O RING	O RING	O RING
4	12500030/0	1	RIVETTO	RIVET	RIVET	NIET
5	27045000/0	1	BOCCA CONVOGLIATORE	CONVEYOR INLET	BOUCHE CONVOYEUR	BLECHSATZEINGANG
6	12815210/0	6	VITE	SCREW	VIS	SCHRAUBE
7	12523040/0	6	ROSETTA	WASHER	RONDELLE	SCHEIBE
8	12154510/0	6	DADO	NUT	ECROU	MUTTER
9	84207250/0	1	ASS. FLANGIA (10÷14)	FLANGE ASS.Y (10÷14)	ENS. BRIDE (10÷14)	NABE, KOMPLETT (10÷14)
10	27023000/0	1	ALBERO	SHAFT	ARBRE	WELLE
11	27208402/0	1	FLANGIA	FLANGE	BRIDE	FLANSCH
12	19216032/0	2	CUSCINETTO	BEARING	ROULEMENT	KUEGELLAGER
13	25160501/0	1	DISCO PARAPOLVERE	DUST COVER	PROTEGE-POUSSIERE	STAUBSCHUTSCHEIBE
14	12609260/0	1	SEEGER	SEEGER	SEEGER	SEEGER
15	12818700/0	4	VITE	SCREW	VIS	SCHRAUBE
17	12154210/0	4	DADO	NUT	ECROU	MUTTER
18	25463200/0	1	MOZZO COLTELLO	BLADE HUB	MOYEU LAME	MESSERHALTER
19	12139100/0	1	LINGUETTA	KEY	CLAVETTE	KEIL
20	84109500/0	1	COLTELLO	BLADE	LAME	MESSER
21	22160400/0	1	DISCO PARAPOLVERE	DUST COVER	PROTEGE-POUSSIERE	STAUBSCHUTSCHEIBE
22	12523080/0	1	RONDELLA	WASHER	RONDELLE	SCHEIBE
23	12735694/0	1	VITE	SCREW	VIS	SCHRAUBE
24	27604000/0	1	PULEGGIA	PULLEY	POULIE	RIEMENSCHLEIBE
25	12139480/0	1	CHIAVETTA	KEY	CLAVETTE	KEIL
26	12793102/0	1	VITE	SCREW	VIS	SCHRAUBE
27	25670007/0	1	RONDELLA	WASHER	RONDELLE	SCHEIBE
28	12583500/0	1	GROWER	GROWER	GROWER	GROWER
29	27488000/0	1	GRIGLIA ASPIRAZIONE	AIR INTAKE GRILL	GRILLE D'ASPIRATION	ANSAUGGITTER
30	12815200/0	4	VITE	SCREW	VIS	SCHRAUBE
31	12523040/0	4	ROSETTA	WASHER	RONDELLE	SCHEIBE





N.	CODE	Q.TY	DESCRIZIONE	DESCRIPTION	DESCRIPTION	BESCHREIBUNG
32	12154510/0	4	DADO	NUT	ECROU	MUTTER
33	12794970/0	1	VITE	SCREW	VIS	SCHRAUBE
34	12523080/0	1	ROSETTA	WASHER	RONDELLE	SCHEIBE
35	12154250/0	1	DADO	NUT	ECROU	MUTTER
36	25510007/1	1	PERNO	PIN	PIVOT	BOLZEN
37	12295200/0	1	DADO	NUT	ECROU	MUTTER
38	12156602/0	1	DADO	NUT	ECROU	MUTTER
—	84564090/0		PIATTO DI TAGLIO ASSEMBLATO (008, 32÷62 + 009, 1÷38)	CUTTING PLATE, ASSEMBLED (008, 32÷62 + 009, 1÷38)	PLATEAU DE COUPE,S COMPLETE (008, 32÷62 + 009, 1÷38)	CHNEIDWERKZEUG, KOMPLETT (008, 32÷62 + 009, 1÷38)
51	27107501/0	1	CONVOGLIATORE	CONVEYOR	CONVOYEUR	BLECHSATZ
52	27140051/1	1	DEFLETTORE	DEFLECTOR	DEFLECTEUR	ABWEISER
53	12735402/0	8	VITE	SCREW	VIS	SCHRAUBE
54	27510097/1	1	PERNO	PIN	PIVOT	BOLZEN
55	24487997/0	2	COPPIGLIA	COTTER PIN	GOUPILLE	SPLIT
56	84108015/0	1	ASS. CONVOGLIATORE (51, 52, 53)	CONVEYOR ASS.Y (51, 52, 53)	ENS. CONVOYEUR (51, 52, 53)	BLECHSATZ, KOMPLETT (51, 52, 53)

contact@enc-motoculture.com

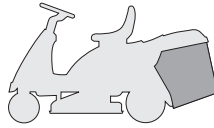
F72**F72 hydro**
**SACCO
GRASSCATCHER
BAC
AUFFANGSACK**

2000

010.0

1 / 1

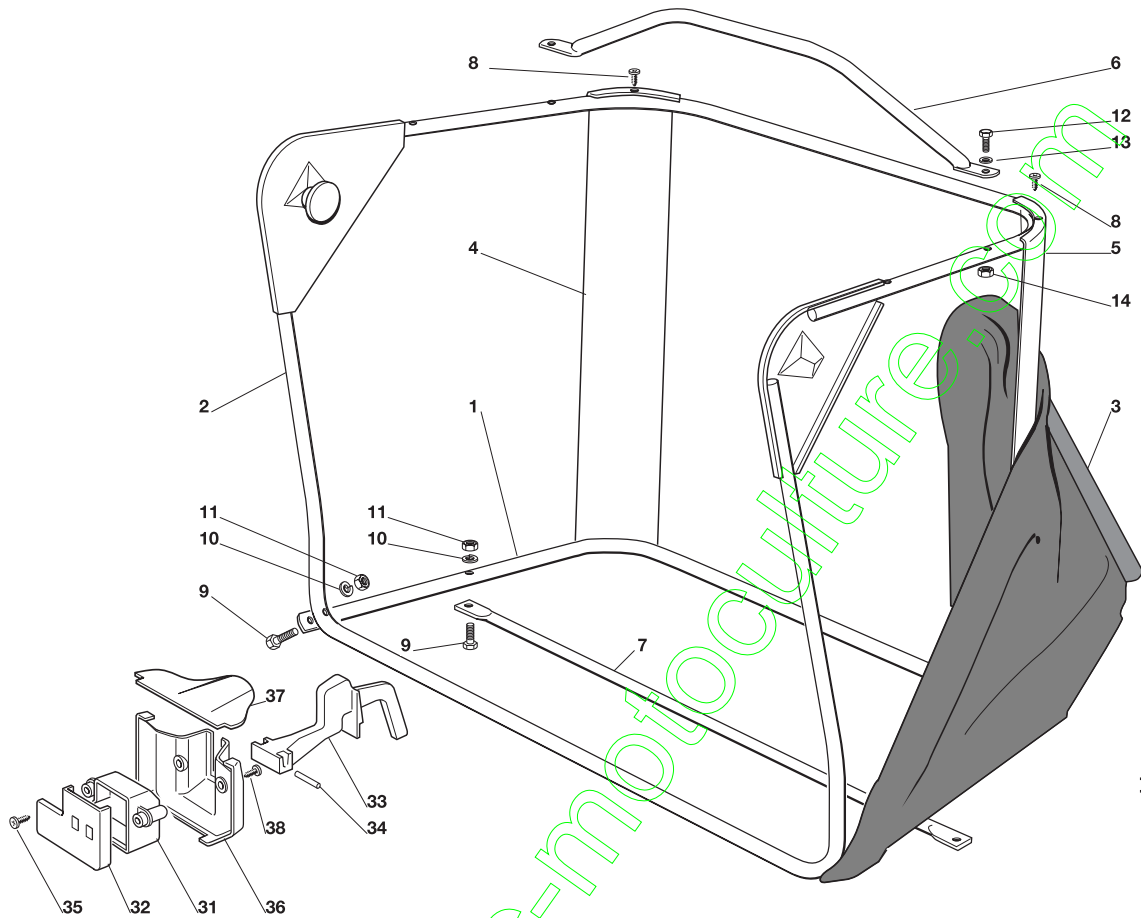
EDIPROM
9852.10

N.	CODE	Q.TY	DESCRIZIONE	DESCRIPTION	DESCRIPTION	BESCHREIBUNG
1	84801103/0	1	TELAIO INFERIORE	LOWER FRAME	CHASSIS INFÉRIEUR	UNTERERRAHMEN
2	84801105/0	1	TELAIO SUPERIORE	UPPER FRAME	CHASSIS SUPÉRIEUR	OBERERRAHMEN
3	84106050/0	1	CONFEZIONE SACCO	GRASSCATCHER	BAC	SACK
4	27010205/0	1	ANGOLARE DESTRO	RIGHT ANGULAR SUPPORT	SUPPORT ANGULAIRE	RECHTER HALTER
			DROITE			
5	27010207/0	1	ANGOLARE SINISTRO	LEFT ANGULAR SUPPORT	SUPPORT ANGULAIRE	LINKER HALTER
6	84869051/0	1	TUBO	ROD	TIGE	STANGE
7	84650100/0	1	RINFORZO	STIFFENING	REINFORCEMENT	VERSTAERKUNG
8	12729601/0	4	VITE	SCREW	VIS	SCHRAUBE
9	12792099/0	2	VITE	SCREW	VIS	SCHRAUBE
10	12582101/0	4	GROWER	GROWER	GROWER	GROWER
11	12292100/0	4	DADO	NUT	ECROU	MUTTER
12	12674701/0	2	VITE	SCREW	VIS	SCHRAUBE
13	12521331/0	2	RONDELLA	WASHER	RONDELLE	SCHEIBE
14	12154510/0	2	DADO	NUT	ECROU	MUTTER
31	25600041/0	1	PROTEZIONE MICRO	MICRO PROTECTION	PROTECTION MICRO	SCHUTZ
32	25600042/0	1	COPERCHIO PROTEZIONE	PROTECTION COVER	COUVERCLE PROTECTION	SCHUTZDEKEL
33	25318124/0	1	LEVA	LEVER	LEVIER	HEBEL
34	12400030/0	1	PERNO	PIN	PIVOT	BOLZEN
35	12728510/0	3	VITE	SCREW	VIS	SCHRAUBE
36	27600058/0	1	DEFLETTORE	DEFLECTOR	DEFLECTEUR	ABWEISER
37	27109500/0	1	CHIUSURA DEFLETTORE	DEFLECTOR COVER	COUVERCLE DEFLECTEUR	ABWEISERDEKEL
38	12728510/0	4	VITE	SCREW	VIS	SCHRAUBE

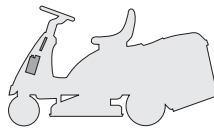
F72*F72 hydro*
PARTI ELETTRICHE
ELECTRICAL PARTS
PARTIES ELECTRIQUES
ELETRISCHETEILE

2000

011M.0

1 / 1

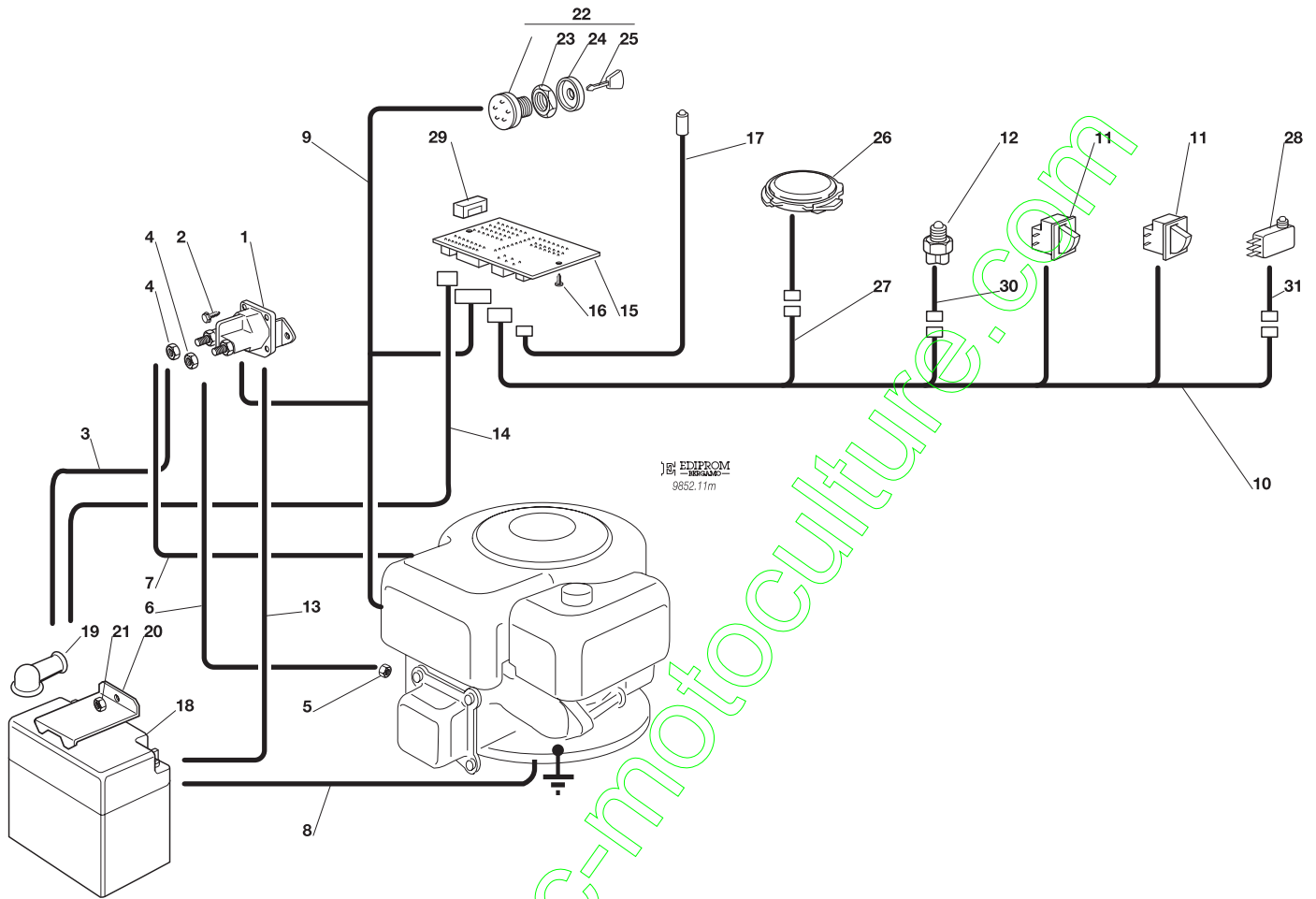

N.	CODE	Q.TY	DESCRIZIONE	DESCRIPTION	DESCRIPTION	BESCHREIBUNG
1	18736110/0	1	RELÉ AVVIAMENTO	STARTER RELAY	RELAIS D'ALLUMAGE	ANLASSRELAIS
2	12735110/0	2	VITE	SCREW	VIS	SCHRAUBE
3	27065050/0	1	CAVO BATT. SOLENOIDE	CABLE	CABLES	KABEL
4	12360352/0	2	DADO	NUT	ECROU	MUTTER
5	12361005/0	1	DADO	NUT	ECROU	MUTTER
6	25065001/0	1	CABLAGGIO SOLEN. AVV.	CABLES ASS.Y	ENS. CABLAGES	KABELSATZ
7	27065051/0	1	CAVO RICARICA	CABLE	CABLES	KABEL
8	25065004/0	1	CAVO MASSA BATTERIA	CABLE	CABLES	KABEL
9	84040100/0	1	CABLAGGIO AVV.	CABLES ASS.Y	ENS. CABLAGES	KABELSATZ
10	84040106/0	1	CABLAGGIO MICRO	CABLES ASS.Y	ENS. CABLAGES	KABELSATZ
11	19410606/0	2	MICRO INTERRUPTORE	MICRO	MICRO	MIKRO
12	19410608/0	1	INTERRUPTORE CAMBIO	GEARBOX SWITCH	INT. BOÎTE DE VITESSE	ANTRIEB SCHALTER
13	25065018/0	1	CAVO MASSA SOLENOIDE	CABLE	CABLES	KABEL
14	27065052/0	1	CAVO ALIM. SCHEDA	CABLE	CABLES	KABEL
15	25722410/0	1	SCHEDA ELETTRONICA	ELECTRONIC CARD	CARTE ELECTRONIQUE	ELEKTRONISCHE KARTE
16	12727810/0	2	VITE	SCREW	VIS	SCHRAUBE
17	25065014/1	1	CAVO LED SEGNALEZIONE	CABLE	CABLES	KABEL
18	18120002/1	1	BATTERIA	BATTERY	BATTERIE	BATTERIE
19	18564862/0	1	CAPPUCCIO	PROTECTION	CAPUCHON	STECKER
20	27772099/0	1	STAFFA	CLAMP	ETRIER	BRIDE
21	12155000/0	1	DADO	NUT	ECROU	MUTTER
22	18450065/1	1	INTERRUPTORE AVVIAMENTO	STARTING SWITCH	INTERRUPTEUR DEMARRAGE	SCHALTER
23	18400861/0	1	GHIERA	SCREWED RING	EMBOUT	NUTMUTTER
24	18565351/0	1	PROTEZIONE GHIERA	SCREWED RING PROTECTION	PROTECTION EMBOUT	NUTMUTTER SCHUTZ
25	18210016/0	1	CHIAVE AVVIAMENTO	STARTING KEY	CLEF A DEMARRAGE	SCHLÜSSEL FÜR START
26	19410607/0	1	MICRO SEDILE	MICRO	MICRO	MIKRO
27	25065020/0	1	CAVO MICRO SEDILE	CABLE	CABLES	KABEL
28	19410605/1	1	MICRO SACCO PIENO	FULL GRASSCATC. MICRO	MICRO BAC PLEIN	VOLLKORB VORRICHTUNG
29	33340033/0	1	FUSIBILE	FUSE	FUSIBLE	SICHERUNG
30	27065050/0	1	CAVO SUPPLEM.	CABLE	CABLES	KABEL
31	25065023/0	1	CAVO SUPPLEM.	CABLE	CABLES	KABEL

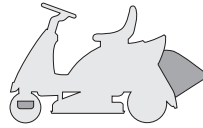
F72**F72 hydro**

ACCESSORI A RICHIESTA
OPTIONALS ON REQUEST
ACCESSOIRES SUR DEMANDE
ZUBEHOERE NACH ANFRAGE

2000

012.0

1 / 1

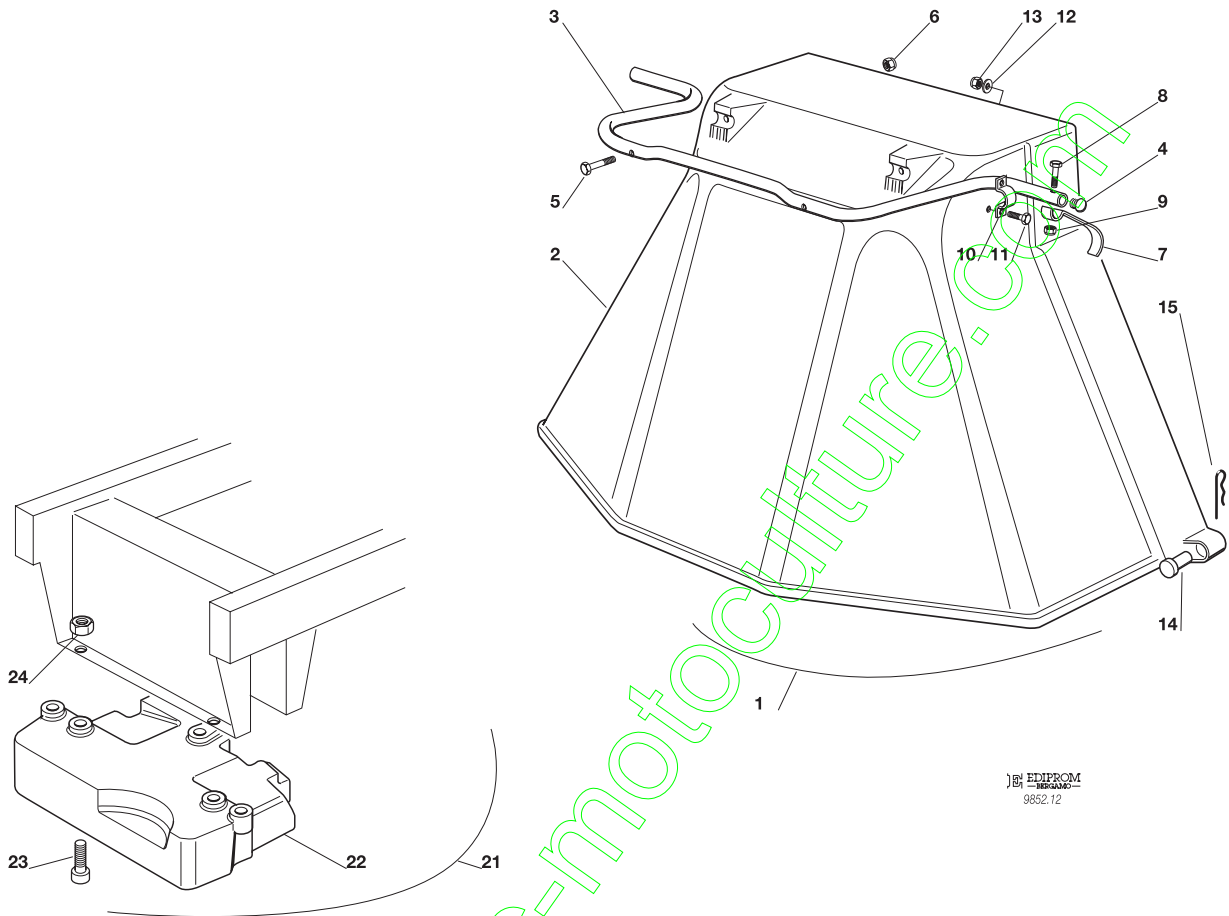

EDIPROM
 9852.12

N.	CODE	Q.TY	DESCRIZIONE	DESCRIPTION	DESCRIPTION	BESCHREIBUNG
1	99900090/0	1	ASS. KIT PROTEZIONE USCITA	EJECTION-GUARD ASS.Y	KIT PROTECTION SORTIE	VORRICHTUNG FÜR AUSWURFSCHUTZ
2	84598062/0	1	PROTEZIONE USCITA	EJECTION GUARD	PROTECTION SORTIE	AUSWURFSCHUTZ
3	27869053/0	1	TUBO DI AGGANCIAMENTO	SUPPORT	SOPPORT	HALTER
4	18566113/0	2	PUNTALE	CAP	BOUCHON	PFROFFEN
5	12674701/0	2	VITE	SCREW	VIS	SCHRAUBE
6	12154510/0	2	DADO	NUT	ECROU	MUTTER
7	25547053/0	1	PIASTRINA	PLATE	PLAQUETTE	PLÄTTCHEN
8	12791500/0	1	VITE	SCREW	VIS	SCHRAUBE
9	12154510/0	1	DADO	NUT	ECROU	MUTTER
10	25547049/0	2	PIASTRINA	PLATE	PLAQUETTE	PLÄTTCHEN
11	12788910/0	4	VITE	SCREW	VIS	SCHRAUBE
12	12523020/0	4	ROSETTA	WASHER	RONDELLE	SCHEIBE
13	12154320/0	4	DADO	NUT	ECROU	MUTTER
14	25510022/0	2	PERNO	PIN	PIVOT	BOLZEN
15	24487998/0	2	COPRIGLIA	COTTER PIN	GOUPILLE	SPLIT
21	99900030/5	1	ASS. KIT PESO ANT.	FRONT WEIGHT KIT	KIT POIDS ANTERIEUR	VORDERGEWICHT VORRICHTUNG
22	25519997/0	1	PESO	WEIGHT	POIDS	GEWICHT
23	12760520/0	3	VITE	SCREW	VIS	SCHRAUBE
24	12155000/0	3	DADO	NUT	ECROU	MUTTER

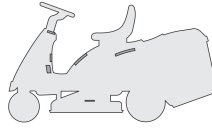
F72**F72 hydro**
ETICHETTE
LABELS
ETIQUETTES
KLEBZETTEL

2000

013.0

1 / 1

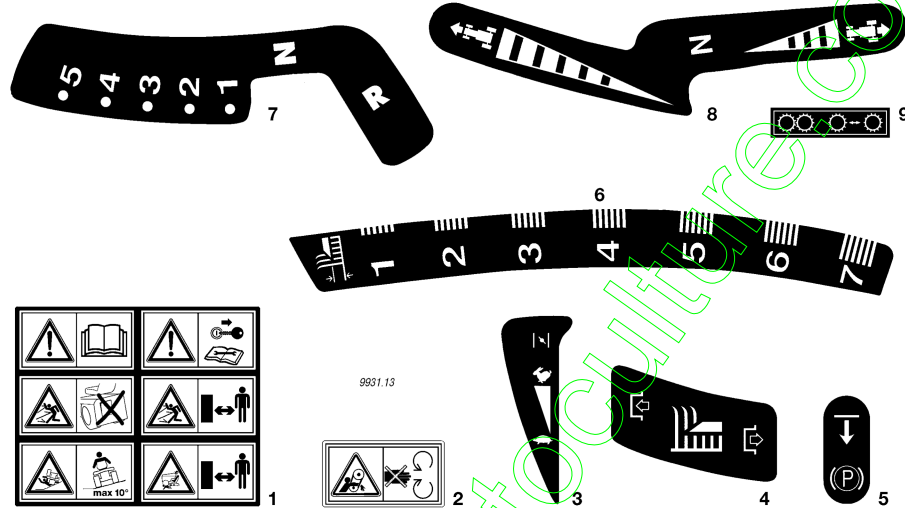

N.	CODE	Q.TY	DESCRIZIONE	DESCRIPTION	DESCRIPTION	BESCHREIBUNG
1	14357428/0	1	ETICHETTA	LABEL	ETIQUETTE	KLEBZETTEL
2	14357519/0	1	ETICHETTA	LABEL	ETIQUETTE	KLEBZETTEL
3	14357425/0	1	ETICHETTA	LABEL	ETIQUETTE	KLEBZETTEL
4	14357431/0	1	ETICHETTA	LABEL	ETIQUETTE	KLEBZETTEL
5	14357526/0	1	ETICHETTA	LABEL	ETIQUETTE	KLEBZETTEL
6	14357427/0	1	ETICHETTA	LABEL	ETIQUETTE	KLEBZETTEL
7	14357426/0	1	ETICHETTA	LABEL	ETIQUETTE	KLEBZETTEL
8	14357702/0	1	ETICHETTA <i>(hydro)</i>	LABEL <i>(hydro)</i>	ETIQUETTE <i>(hydro)</i>	KLEBZETTEL <i>(hydro)</i>
9	14357423/1	1	ETICHETTA <i>(hydro)</i>	LABEL <i>(hydro)</i>	ETIQUETTE <i>(hydro)</i>	KLEBZETTEL <i>(hydro)</i>

F72*F72 hydro*

SCHEMA ELETTRICO
WIRE DIAGRAM
SCHEMA ELECTRIQUE
ELEKTRISCHE SCHEMA

10,5 - 8,5 HP B&S - 10 HP TECUMSEH

2000

014M.0

1 / 1

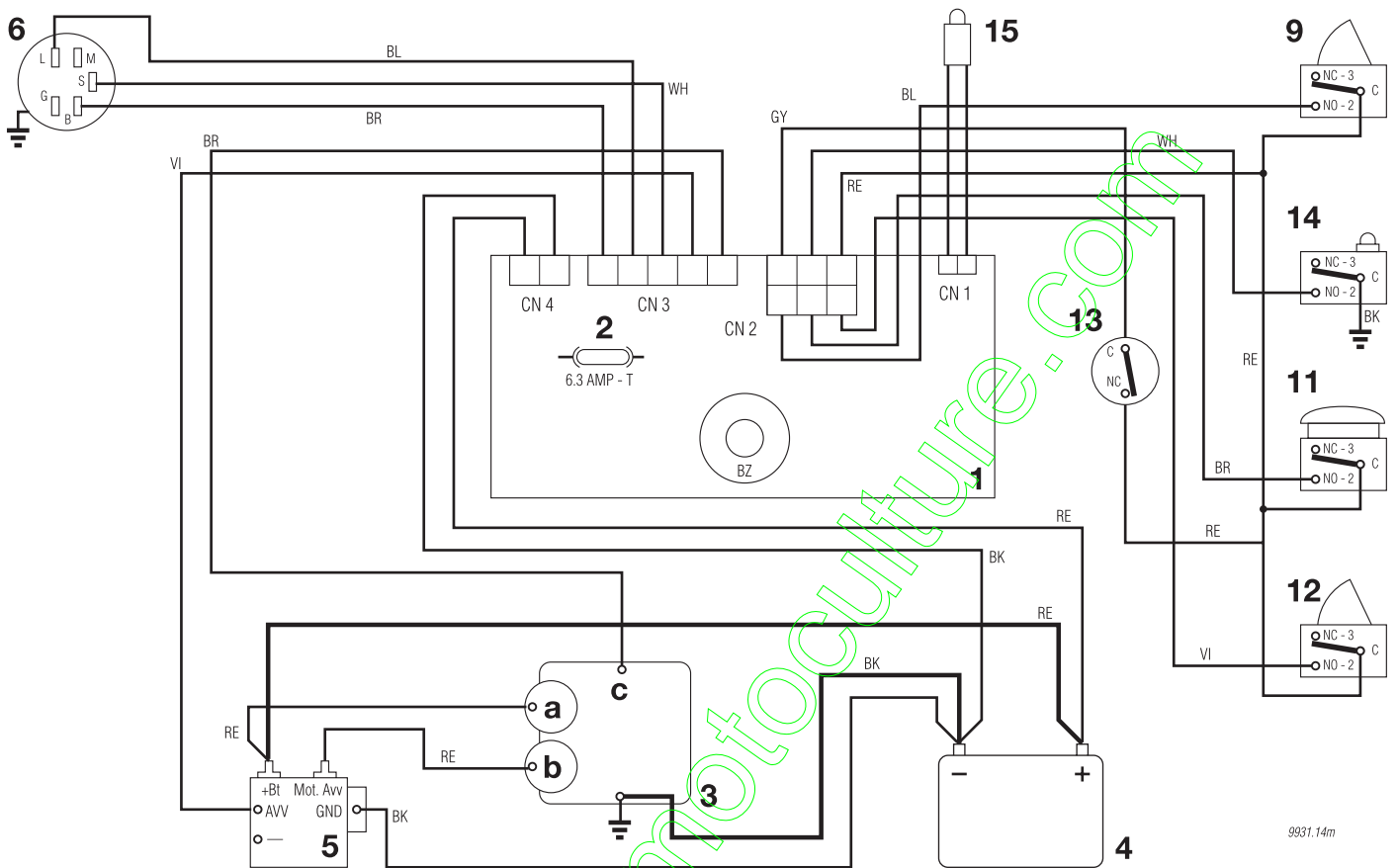

9331.14m

1	SCHEDA CON BUZZER	ELECTRONIC CARD WITH BUZZER	CARTE ELECTRONIQUE AVEC BUZZER	ELECTRONISCHE KARTE MIT BUZZER
2	FUSIBILE 6,3 Amp. T	FUSE 6.3 Amp. T	FUSIBLE 6,3 Amp. T	SICHERUNG 6,3 Amp. T
3	MOTORE	ENGINE	MOTEUR	MOTOR
3a	Generatore	Generator	Genérateur	Generator
3b	Motorino avviamento	Starter	Demarreur	Anlasser
3c	Stop motore	Engine stop	Calage du moteur	Motor abstellung
4	BATTERIA	BATTERY	BATTERIE	BATTERIE
5	RELE AVVIAMENTO	STARTER RELAY	RELAIS DE DEMARRAGE	ANLASSER RELAIS
6	INTERRUTTORE A CHIAVE	ELECTROLOCK	INTERRUPTEUR D'ALLUMAGE	SCHLÜSSELSCHALTER
9	MICROINTERRUTTORE LAME	BLADES MICRO SWITCH	MICRO INTERRUPTEUR LAMES	MESSER MIKROSCHALTER
11	MICROINTERRUTTORE SEDILE	SEAT MICRO SWITCH	MICRO INTERRUPTEUR SIEGE	SITZMIKROSCHALTER
12	MICROINTERRUTTORE SACCO	GRASSCATCHER MICRO SWITCH	MICRO INTERRUPTEUR BAC	GRASFANGEINRICHTUNG MIKROSCHALTER
13	MICROINTERRUTTORE FOLLE	NEUTRAL MICROSWITCH	MICRO INT. POINT MORT	LEERLAUF MIKROSCHALTER
14	MICROINTERRUTTORE SACCO PIENO	FULL GRASSCATCHER MICRO SWITCH	MICRO BAC PLEIN	VOLLKORB VORRICHTUNG
15	SPIA	WARNING LIGHT	VOYANT	KONTROLLAMPE

COLORI CAVI

BK	NERO
BL	BLU
BR	MARRONE
GY	GRIGIO
RE	ROSSO
VI	VIOLA
YG	GIALLO/VERDE
WH	BIANCO

CABLE COLOURS

BLACK
BLUE
BROWN
GREY
RED
VIOLET
YELLOW/GREEN
WHITE

COULEUR CABLES

NOIR
BLEU
BRUN
GRIS
ROUGE
VIOLET
JAUNE/VERT
BLANC

KABEL FARBEN

SCHWARZ
BLAU
BRAUN
GRAU
ROT
VIOLETT
GELB/GRÜN
WEISS

F72

F72 hydro

SCHEMA ELETTRICO
WIRE DIAGRAM
SCHEMA ELECTRIQUE
ELEKTRISCHE SCHEMA

10,5 - 8,5 HP B&S - 10 HP TECUMSEH

2000

014Y.0

1 / 1

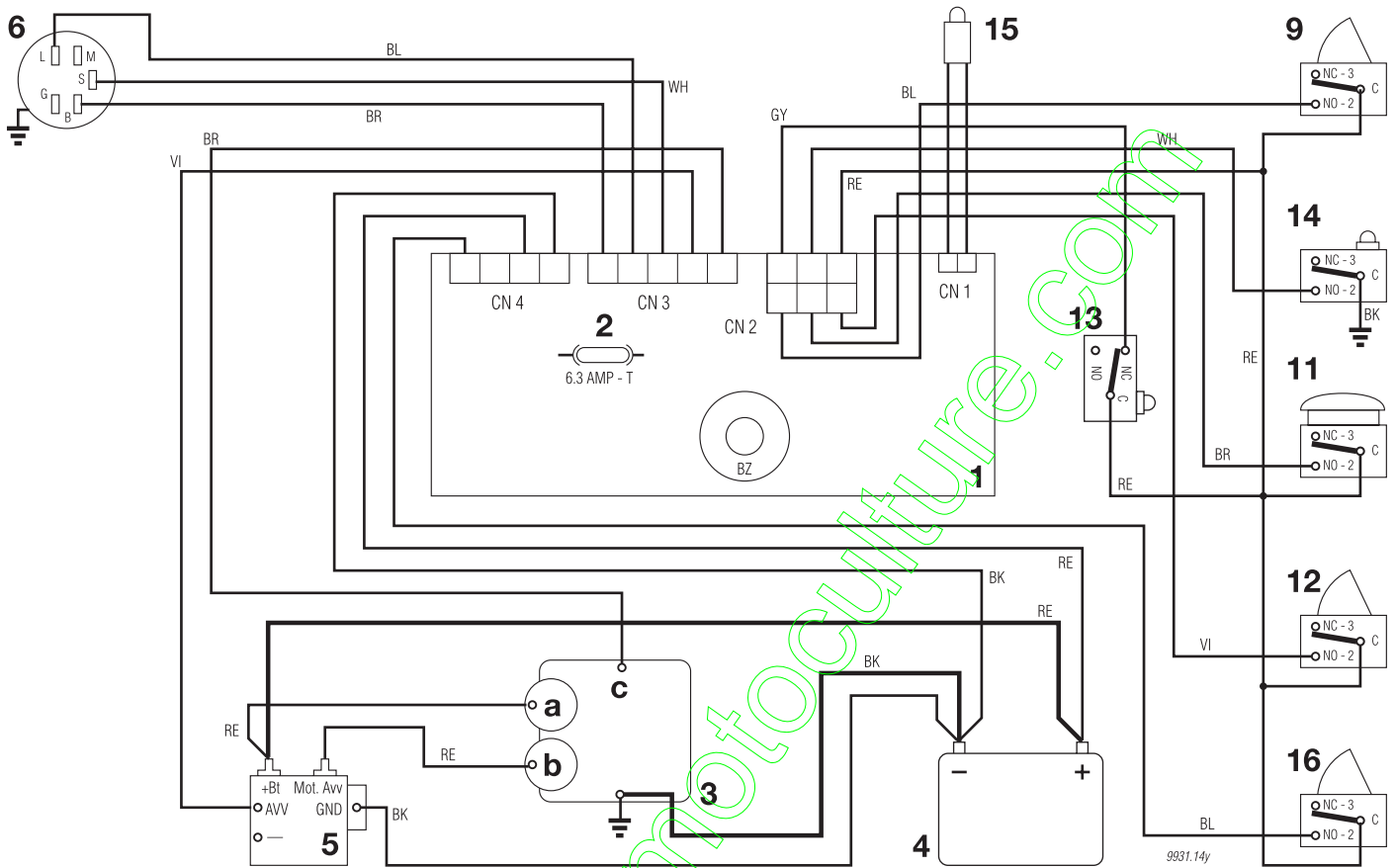

1	SCHEDA CON BUZZER	ELECTRONIC CARD WITH BUZZER	CARTE ELECTRONIQUE AVEC BUZZER	ELECTRONISCHE KARTE MIT BUZZER
2	FUSIBILE 6,3 Amp. T	FUSE 6.3 Amp. T	FUSIBLE 6,3 Amp. T	SICHERUNG 6,3 Amp. T
3	MOTORE	ENGINE	MOTEUR	MOTOR
3a	Generatore	Generator	Generateur	Generator
3b	Motorino avviamento	Starter	Demarreur	Anlasser
3c	Stop motore	Engine stop	Calage du moteur	Motor abstellung
4	BATTERIA	BATTERY	BATTERIE	BATTERIE
5	RELE AVVIAMENTO	STARTER RELAY	RELAIS DE DEMARRAGE	ANLASSER RELAIS
6	INTERRUTTORE A CHIAVE	ELECTROLOCK	INTERRUPTEUR D'ALLUMAGE	SCHLÜSSELSCHALTER
9	MICROINTERRUTTORE LAME	BLADES MICRO SWITCH	MICRO INTERRUPTEUR LAMES	MESSER MIKROSCHALTER
11	MICROINTERRUTTORE SEDILE	SEAT MICRO SWITCH	MICRO INTERRUPTEUR SIEGE	SITZMIKROSCHALTER
12	MICROINTERRUTTORE SACCO	GRASSCATCHER MICRO SWITCH	MICRO INTERRUPTEUR BAC	GRASFANGEINRICHTUNG MIKROSCHALTER
13	MICROINTERRUTTORE FOLLE	NEUTRAL MICROSWITCH	MICRO INT. POINT MORT	LEERLAUF MIKROSCHALTER
14	MICROINTERRUTTORE SACCO PIENO	FULL GRASSCATCHER MICRO SWITCH	MICRO BAC PLEIN	VOLLKORB VORRICHTUNG
15	SPIA	WARNING LIGHT	VOYANT	KONTROLLAMPE
16	MICROINTERRUTTORE FRENO	BRAKE MICRO SWITCH	MICRO INTERRUPTEUR FREIN	BREMSE MIKROSCHALTER

COLORI CAVI

BK	NERO
BL	BLU
BR	MARRONE
GY	GRIGIO
RE	ROSSO
VI	VIOLA
YG	GIALLO/VERDE
WH	BIANCO

CABLE COLOURS

BK	BLACK
BL	BLUE
BR	BROWN
GY	GREY
RE	RED
VI	VIOLET
YG	YELLOW/GREEN
WH	WHITE

COULEUR CABLES

BK	NOIR
BL	BLEU
BR	BRUN
GY	GRIS
RE	ROUGE
VI	VIOLET
YG	JAUNE/VERT
WH	BLANC

KABEL FARBEN

BK	SCHWARZ
BL	BLAU
BR	BRAUN
GY	GRAU
RE	ROT
VI	VIOLETT
YG	GELB/GRÜN
WH	WEISS

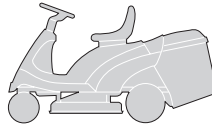
F72**F72 hydro**
ELENCO NUMERICO
NUMERICAL LIST
LISTE NUMERIQUE
NUMERISCHE AUFSTELLUNG

2000

000.0

5 / 7

CODE	TABLE	N.	Q.TY	CODE	TABLE	N.	Q.TY	CODE	TABLE	N.	Q.TY
12001000/0	003	25	2	12293200/0	004Y	25	2	12523060/0	006M	32	1
12001000/0	003	56	2	12293200/0	004Y	73	2	12523060/0	006Y	13	1
12001000/0	003	9	2	12293200/0	004Y	87	2	12523060/0	006Y	29	1
12001010/0	006M	56	2	12293200/0	005	5	1	12523060/0	008	44	1
12001010/0	006Y	56	2	12293200/0	005a	5	1	12523060/0	008	49	1
12139100/0	009	19	1	12293200/0	005b	5	1	12523070/0	002	21	2
12139430/0	006M	22	1	12293200/0	006M	17	2	12523070/0	008	40	1
12139480/0	009	25	1	12293200/0	007	21	1	12523070/0	008	45	1
12154210/0	009	17	4	12293200/0	008	15	4	12523080/0	009	22	1
12154250/0	009	35	1	12293200/0	008	57	1	12523080/0	009	34	1
12154320/0	012	13	4	12293201/0	001	10	4	12523100/0	003	28	1
12154510/0	002	17	2	12293201/0	001	13	4	12523150/0	003	31	1
12154510/0	002	86	2	12293201/0	001	17	4	12540040/0	004M	53	1
12154510/0	004M	21	1	12293201/0	001	36	4	12540260/0	005	6	2
12154510/0	004Y	21	1	12293201/0	002	84	6	12540260/0	005a	6	2
12154510/0	004Y	79	1	12293201/0	004M	33	1	12540260/0	005b	6	2
12154510/0	004Y	84	2	12293201/0	004Y	61	1	12540260/0	006M	8	1
12154510/0	005b	20	1	12293201/0	005	4	3	12540260/0	006Y	8	1
12154510/0	006Y	46	2	12293201/0	005a	4	3	12543000/0	006M	3	1
12154510/0	007	30	1	12293201/0	005b	4	3	12543000/0	006Y	3	1
12154510/0	008	12	2	12293201/0	006M	33	1	12581200/0	002	43	2
12154510/0	009	32	4	12293201/0	006Y	30	1	12582100/0	005	10	1
12154510/0	009	8	6	12293201/0	008	50	1	12582100/0	005a	10	1
12154510/0	010	14	2	12295200/0	007	15	1	12582100/0	006Y	37	1
12154510/0	012	6	2	12295200/0	009	37	1	12582101/0	010	10	4
12154510/0	012	9	1	12295300/0	003	30	1	12583500/0	002	55	4
12155000/0	001	24	1	12360352/0	011M	4	2	12583500/0	004M	50	1
12155000/0	002	22	2	12360352/0	011Y	4	2	12583500/0	005b	15	2
12155000/0	004M	41	1	12361005/0	011M	5	1	12583500/0	009	28	1
12155000/0	004M	48	1	12361005/0	011Y	5	1	12583501/0	003	12	1
12155000/0	004M	5	2	12379511/0	001	26	2	12587100/0	003	29	1
12155000/0	004Y	5	2	12379511/0	003	22	2	12608600/0	004M	36	1
12155000/0	004Y	58	1	12379511/0	004Y	53	1	12608950/0	006M	23	1
12155000/0	006M	14	2	12400030/0	010	34	1	12609260/0	009	14	1
12155000/0	006M	18	1	12436030/0	003	6	1	12620299/0	002	62	1
12155000/0	006M	20	2	12436050/0	007	23	1	12622650/0	003	3	1
12155000/0	006M	27	4	12437502/0	002	75	2	12674550/0	006Y	45	2
12155000/0	006M	35	1	12437503/0	002	13	2	12674700/0	007	29	1
12155000/0	006Y	14	2	12500030/0	009	4	1	12674701/0	010	12	2
12155000/0	006Y	24	4	12500090/0	001	25	1	12674701/0	012	5	2
12155000/0	006Y	32	1	12520010/0	006M	57	0-4	12691100/0	005	3	1
12155000/0	007	22	1	12520010/0	006Y	57	0-4	12691100/0	005a	3	1
12155000/0	007	26	1	12520031/0	003	10	0-2	12691100/0	005b	3	1
12155000/0	008	18	1	12521320/0	002	74	2	12691200/0	002	20	2
12155000/0	008	46	1	12521330/0	004Y	54	1	12691800/0	006M	25	4
12155000/0	008	54	1	12521330/0	004Y	83	4	12691800/0	006Y	22	4
12155000/0	008	58	1	12521331/0	001	19	2	12691900/0	008	48	1
12155000/0	008	6	1	12521331/0	002	28	4	12692050/0	004M	40	1
12155000/0	011M	21	1	12521331/0	010	13	2	12692050/0	004Y	57	1
12155000/0	011Y	21	1	12521350/0	001	35	2	12692050/0	008	5	1
12155000/0	012	24	3	12521350/0	004M	17	2	12692080/0	008	43	1
12155010/0	001	32	2	12521350/0	004Y	17	2	12692695/0	003	27	1
12155010/0	004Y	40	1	12521350/0	004Y	90	1	12726288/0	006Y	42	1
12155010/0	004Y	75	1	12521350/0	006M	26	4	12726388/0	002	45	1
12155010/0	004Y	89	1	12521350/0	006M	34	1	12727810/0	011M	16	2
12155010/0	006M	11	1	12521350/0	006Y	23	4	12727810/0	011Y	16	2
12155010/0	006Y	11	1	12521350/0	006Y	31	1	12728440/0	001	40	1
12155010/0	008	35	1	12521370/0	003	5	1	12728460/0	002	73	2
12155020/0	004Y	43	1	12521370/0	004M	35	2	12728510/0	010	35	3
12155020/0	004Y	52	1	12521370/0	006Y	34	1	12728510/0	010	38	4
12156602/0	003	19	4	12521410/0	006M	54	2	12729601/0	002	27	4
12156602/0	007	13	1	12521410/0	006Y	54	2	12729601/0	010	8	4
12156602/0	007	16	1	12523020/0	006Y	49	1	12731350/0	004M	7	4
12156602/0	007	6	1	12523020/0	012	12	4	12731350/0	004Y	7	4
12156602/0	009	38	1	12523040/0	001	43	1	12731350/0	007	10	4
12290800/0	002	46	1	12523040/0	002	11	2	12731350/0	007	3	4
12290800/0	006Y	43	1	12523040/0	002	16	2	12731601/0	004M	10	4
12292100/0	010	11	4	12523040/0	009	31	4	12731601/0	004Y	10	4
12292102/0	001	7	8	12523040/0	009	7	6	12731601/0	005b	23	1
12292102/0	005b	25	1	12523050/0	004M	20	1	12731601/0	006Y	48	1
12293200/0	001	22	2	12523050/0	004Y	20	1	12731601/0	008	8	4
12293200/0	004M	14	2	12523050/0	006Y	35	1	12734995/0	001	18	2
12293200/0	004M	25	2	12523060/0	001	23	1	12735104/0	005	11	1
12293200/0	004M	51	1	12523060/0	002	56	4	12735104/0	005a	11	1
12293200/0	004Y	14	2	12523060/0	006M	13	1	12735106/0	001	48	2





CODE	TABLE	N.	Q.TY	CODE	TABLE	N.	Q.TY	CODE	TABLE	N.	Q.TY
12735106/0	005b	17	4	18375053/0	005b	11	1	25065023/0	011Y	31	1
12735110/0	001	46	2	18400861/0	011M	23	1	25108007/0	005a	22	1
12735110/0	004Y	48	2	18400861/0	011Y	23	1	25110267/0	004Y	2	1
12735110/0	005	20	2	18400915/1	006M	24	1	25110269/0	004M	2	1
12735110/0	005a	20	2	18400930/1	006Y	21	1	25122000/1	001	37	2
12735110/0	005b	27	2	18401001/0	005	14	1	25122200/1	003	53	4
12735110/0	011M	2	2	18401001/0	005a	14	1	25160012/0	006Y	44	2
12735110/0	011Y	2	2	18401001/0	005b	9	1	25160016/0	003	26	1
12735120/0	001	42	1	18450065/1	011M	22	1	25160501/0	009	13	1
12735140/0	006Y	39	2	18450065/1	011Y	22	1	25318124/0	010	33	1
12735150/0	006M	29	2	18564862/0	011M	19	1	25394501/0	002	44	1
12735150/0	006Y	26	2	18564862/0	011Y	19	1	25394503/1	004M	42	1
12735402/0	002	24	4	18565351/0	011M	24	1	25394503/1	004Y	59	1
12735402/0	002	26	2	18565351/0	011Y	24	1	25430205/0	001	33	2
12735402/0	002	9	10	18566113/0	012	4	2	25430210/0	008	51	1
12735402/0	009	53	8	18736110/0	011M	1	1	25430220/0	004M	23	1
12735410/0	002	10	8	18736110/0	011Y	1	1	25430220/0	004Y	23	1
12735510/0	005	9	1	18737849/0	005	13	1	25430220/0	008	9	1
12735510/0	005a	9	1	18737849/0	005a	13	1	25430226/0	004M	39	1
12735520/0	004M	52	1	18737849/0	005b	8	1	25430226/0	004Y	56	1
12735520/0	006Y	36	1	18738216/0	005b	16	1	25430226/0	008	4	1
12735598/0	002	12	2	18738217/0	005a	7	1	25430236/0	004M	16	1
12735694/0	009	23	1	18738218/0	005b	13	1	25430236/0	004Y	16	1
12737310/0	006M	2	1	19035000/0	009	3	1	25463200/0	009	18	1
12737310/0	006Y	2	1	19216032/0	006Y	12	2	25510007/1	007	11	1
12737450/0	005b	14	2	19410605/1	011M	28	1	25510007/1	009	36	1
12760520/0	012	23	3	19410605/1	011Y	28	1	25510022/0	012	14	2
12788512/0	002	42	2	19410606/0	011M	11	2	25510040/1	004M	46	1
12788910/0	012	11	4	19410606/0	011Y	11	3	25510040/1	004Y	72	1
12790780/0	005b	24	1	19410607/0	011M	26	1	25510040/1	004Y	86	1
12791200/0	001	6	8	19410607/0	011Y	26	1	25510040/1	006M	16	1
12791200/0	002	15	2	19410608/0	011M	12	1	25510040/1	007	20	1
12791200/0	008	11	2	19410609/0	011Y	12	1	25510040/1	008	16	1
12791400/0	004Y	78	1	22041980/0	008	32	1	25510040/1	008	52	1
12791400/0	004Y	82	2	22110230/0	003	57	2	25519997/0	012	22	1
12791500/0	012	8	1	22110230/0	006M	58	2	25547012/1	001	5	2
12792099/0	010	9	2	22110230/0	006Y	58	2	25547033/0	002	53	1
12792611/0	001	12	4	22160400/0	009	21	1	25547049/0	004M	9	2
12792611/0	001	16	4	22171001/0	004M	18	1	25547049/0	004Y	9	2
12792611/0	001	9	4	22171001/0	004Y	18	1	25547049/0	008	7	2
12793101/0	002	54	4	22399801/0	006Y	41	1	25547049/0	012	10	2
12793102/0	003	11	1	22446402/0	006Y	15	1	25547053/0	012	7	1
12793102/0	004M	32	1	22524970/1	001	31	2	25600020/0	002	71	1
12793102/0	006M	30	1	22672151/0	004Y	35	2	25600021/1	002	72	1
12793102/0	006Y	27	1	22672151/0	006M	9	1	25600041/0	010	31	1
12793102/0	008	34	1	22672151/0	006Y	9	1	25600042/0	010	32	1
12793102/0	009	26	1	22672152/0	008	33	1	25601554/0	006M	12	1
12793301/0	004M	4	2	22672152/0	008	41	2	25601554/0	006Y	12	1
12793301/0	004Y	4	2	22680007/0	004Y	74	2	25670005/1	003	55	2
12793301/0	004Y	60	1	22680009/0	004M	54	1	25670005/1	006M	55	2
12793301/0	006M	31	1	22746600/0	003	17	4	25670005/1	006Y	55	2
12793301/0	006Y	28	1	22746601/0	004M	44	2	25670007/0	009	27	1
12793701/0	001	21	2	22746601/0	008	14	1	25670008/0	004Y	51	1
12793701/0	005	2	3	22943005/0	004M	24	1	25670008/0	007	12	2
12793701/0	005a	2	3	22943005/0	004Y	24	1	25670008/0	007	17	2
12793701/0	005b	2	3	24487997/0	004M	22	1	25670008/0	007	5	2
12794900/0	004Y	42	1	24487997/0	004M	49	1	25670008/0	007	7	2
12794970/0	009	33	1	24487997/0	004Y	22	1	25670011/0	004M	47	2
12815200/0	009	30	4	24487997/0	007	18	1	25670011/0	004Y	38	1
12815210/0	009	6	6	24487997/0	007	4	1	25670011/0	004Y	88	2
12815240/0	005b	19	1	24487997/0	008	56	1	25670011/0	006M	10	1
12818700/0	009	15	4	24487997/0	009	55	2	25670011/0	006M	19	2
14357423/1	013	9	1	24487998/0	004Y	77	1	25670011/0	006Y	10	1
14357425/0	013	3	1	24487998/0	004Y	91	1	25670011/0	007	24	1
14357426/0	013	7	1	24487998/0	012	15	2	25670011/0	007	25	2
14357427/0	013	6	1	25033060/0	009	2	1	25670011/0	008	17	2
14357428/0	013	1	1	25034002/1	001	2	2	25670011/0	008	53	2
14357431/0	013	4	1	25034002/1	003	21	4	25722410/0	011M	15	1
14357519/0	013	2	1	25038003/0	003	2	1	25722411/0	011Y	15	1
14357526/0	013	5	1	25065001/0	011M	6	1	25722453/1	002	51	1
14357702/0	013	8	1	25065001/0	011Y	6	1	25774275/0	004M	19	1
18120002/1	011M	18	1	25065004/0	011M	8	1	25774275/0	004Y	19	1
18120002/1	011Y	18	1	25065004/0	011Y	8	1	25785114/0	002	52	1
18210016/0	011M	25	1	25065014/1	011M	17	1	25795000/0	002	82	1
18210016/0	011Y	25	1	25065014/1	011Y	17	1	25840003/0	007	14	1
18375051/1	005	18	3	25065018/0	011M	13	1	25869004/0	005	15	1
18375051/1	005a	18	3	25065018/0	011Y	13	1	25869004/0	005a	15	1
18375051/1	005b	12	3	25065020/0	011M	27	1	25869004/0	005b	10	1
18375053/0	005	17	1	25065020/0	011Y	27	1	25943001/0	001	34	2
18375053/0	005a	17	1	25065023/0	011M	31	1	25950000/0	006M	59	2





CODE	TABLE	N.	Q.TY	CODE	TABLE	N.	Q.TY	CODE	TABLE	N.	Q.TY
25950000/0	006Y	59	2	27510097/1	009	54	1	84108015/0	009	56	1
25950002/0	003	58	2	27510103/0	004M	15	1	84109500/0	009	20	1
25961201/0	002	61	1	27510103/0	004Y	15	1	84110100/1	002	8	1
27010205/0	010	4	1	27520050/0	003	1	1	84110102/1	002	8	1
27010207/0	010	5	1	27546001/0	002	23	2	84110103/1	002	8	1
27023000/0	009	10	1	27546003/0	002	25	2	84110104/1	002	8	1
27034051/0	008	55	1	27546009/0	005b	21	1	84110107/1	002	8	1
27034052/0	004M	43	1	27546015/0	004M	6	2	84110109/1	002	8	1
27034054/0	006M	15	1	27546015/0	004Y	6	2	84110110/1	002	8	1
27034056/0	002	85	1	27546015/0	007	2	2	84110111/1	002	8	1
27034057/0	004Y	71	1	27546015/0	007	9	2	84110125/0	002	8	1
27034058/0	004Y	85	1	27546019/0	006Y	38	1	84110126/0	002	8	1
27034059/0	004M	13	1	27546023/0	006Y	47	1	84207101/0	004Y	80	1
27034060/0	004Y	13	1	27570050/0	003	4	1	84207250/0	009	9	1
27034061/0	008	13	1	27590050/0	003	54	2	84220501/0	008	31	1
27037000/0	001	4	1	27590051/0	006M	52	1	84230401/0	003	23	1
27045000/0	009	5	1	27590051/0	006Y	53	1	84230403/0	003	24	1
27045080/0	004Y	33	2	27590052/0	003	54	2	84317051/1	004M	37	1
27047000/0	008	38	1	27590053/0	006M	53	1	84317051/1	004Y	55	1
27047002/0	004M	34	2	27590053/0	006Y	53	1	84317055/0	006M	6	1
27047003/0	002	18	2	27598060/0	005	12	1	84317059/0	008	1	1
27063020/0	004Y	47	2	27598060/0	005a	12	1	84317061/0	008	37	1
27065050/0	011M	3	1	27598060/0	005b	7	1	84317065/0	007	27	1
27065050/0	011M	30	1	27600058/0	010	36	1	84317067/0	006Y	6	1
27065050/0	011Y	3	1	27600059/1	005	19	1	84503001/0	004M	1	1
27065051/0	011M	7	1	27600059/1	005a	19	1	84503001/0	004Y	1	1
27065051/0	011Y	7	1	27600059/1	005b	26	1	84545051/3	001	3	1
27065052/0	011M	14	1	27600091/0	002	2	1	84564090/0	009	-	1
27065057/0	011Y	14	1	27600092/0	002	2	1	84564092/0	009	1	1
27107501/0	009	51	1	27600093/0	002	2	1	84598053/0	005a	8	1
27109500/0	010	37	1	27600094/0	002	2	1	84598061/0	005b	22	1
27109501/0	002	7	1	27600108/0	002	2	1	84598062/0	012	2	1
27109505/0	002	7	1	27604000/0	009	24	1	84598064/0	002	1	1
27109506/0	002	7	1	27604002/0	008	47	1	84598065/0	002	1	1
27109507/0	002	7	1	27604003/1	006M	1	1	84598066/0	002	1	1
27109514/0	002	7	1	27604005/0	006Y	1	1	84598067/0	002	1	1
27110300/2	002	3	1	27670053/0	004Y	45	2	84598075/0	002	1	1
27110302/1	002	4	1	27733000/2	002	81	1	84640550/0	005	7	1
27110303/0	002	5	1	27734055/0	004Y	41	1	84650100/0	010	7	1
27110304/0	002	29	1	27772067/0	006M	28	2	84680050/0	006M	51	2
27110305/0	002	30	1	27772067/0	006Y	25	2	84680050/0	006Y	51	2
27110306/0	002	6	1	27772095/0	001	47	1	84680052/0	003	51	2
27110309/2	002	3	1	27772099/0	011M	20	1	84680053/0	006M	51	2
27110310/2	002	3	1	27772099/0	011Y	20	1	84680053/0	006Y	51	2
27110311/2	002	3	1	27772101/0	004Y	36	1	84680055/0	003	51	2
27110317/1	002	4	1	27772103/0	004Y	37	1	84735551/0	003	7	1
27110318/1	002	4	1	27772105/0	004Y	81	1	84773551/0	004M	31	1
27110319/1	002	4	1	27787025/0	001	15	2	84773553/0	004M	38	1
27110321/0	002	5	1	27840050/0	003	16	2	84773557/0	005b	18	1
27110322/0	002	5	1	27869053/0	012	3	1	84773561/0	004Y	34	1
27110323/0	002	5	1	33320506/0	001	44	1	84773563/0	004Y	49	1
27110345/0	002	3	1	33340033/0	011M	29	1	84773565/0	004Y	46	1
27110348/0	002	4	1	33340033/0	011Y	29	1	84773567/0	004Y	76	1
27110349/0	002	5	1	35061400/0	006M	5	1	84773568/0	004Y	32	1
27140051/1	009	52	1	35061405/0	006Y	5	1	84783005/1	002	83	1
27158000/0	004Y	44	2	35061424/0	008	59	1	84783009/0	001	11	1
27160051/0	008	39	1	81000772/1	008	42	1	84801103/0	010	1	1
27208402/0	009	11	1	81007092/0	006Y	40	1	84801105/0	010	2	1
27275000/0	004Y	26	1	82598001/0	005	8	1	84801107/2	001	14	1
27294001/0	001	41	1	82601503/0	006M	21	1	84801111/0	001	8	1
27294002/0	001	45	1	84000250/0	002	41	1	84801113/0	001	1	1
27315059/0	008	36	1	84000501/0	003	8	1	84869051/0	010	6	1
27315077/0	004M	45	1	84001003/0	007	1	1	99900030/5	012	21	1
27315089/0	006Y	33	1	84001005/1	007	8	1	99900090/0	012	1	1
27395050/0	004M	12	1	84001007/0	008	3	1				
27395050/0	004Y	12	1	84001011/2	004M	8	1				
27395051/0	008	2	1	84001011/2	004Y	8	1				
27395052/0	007	28	1	84001015/1	004M	3	1				
27430551/1	002	19	2	84001015/1	004Y	3	1				
27430552/0	004M	11	1	84002051/0	007	19	1				
27430552/0	004Y	11	1	84034053/0	003	20	1				
27430554/0	001	39	1	84040100/0	011M	9	1				
27430555/0	007	31	1	84040100/0	011Y	9	1				
27430560/0	004Y	50	1	84040106/0	011M	10	1				
27430562/0	005	21	1	84040106/0	011Y	10	1				
27430562/0	005a	21	1	84040300/0	001	20	1				
27487000/0	008	10	1	84044000/0	003	52	2				
27488000/0	009	29	1	84044001/0	006M	52	1				
27510096/0	006M	7	1	84044001/0	006Y	52	1				
27510096/0	006Y	7	1	84106050/0	010	3	1				