

# 72

# 72 Hydro

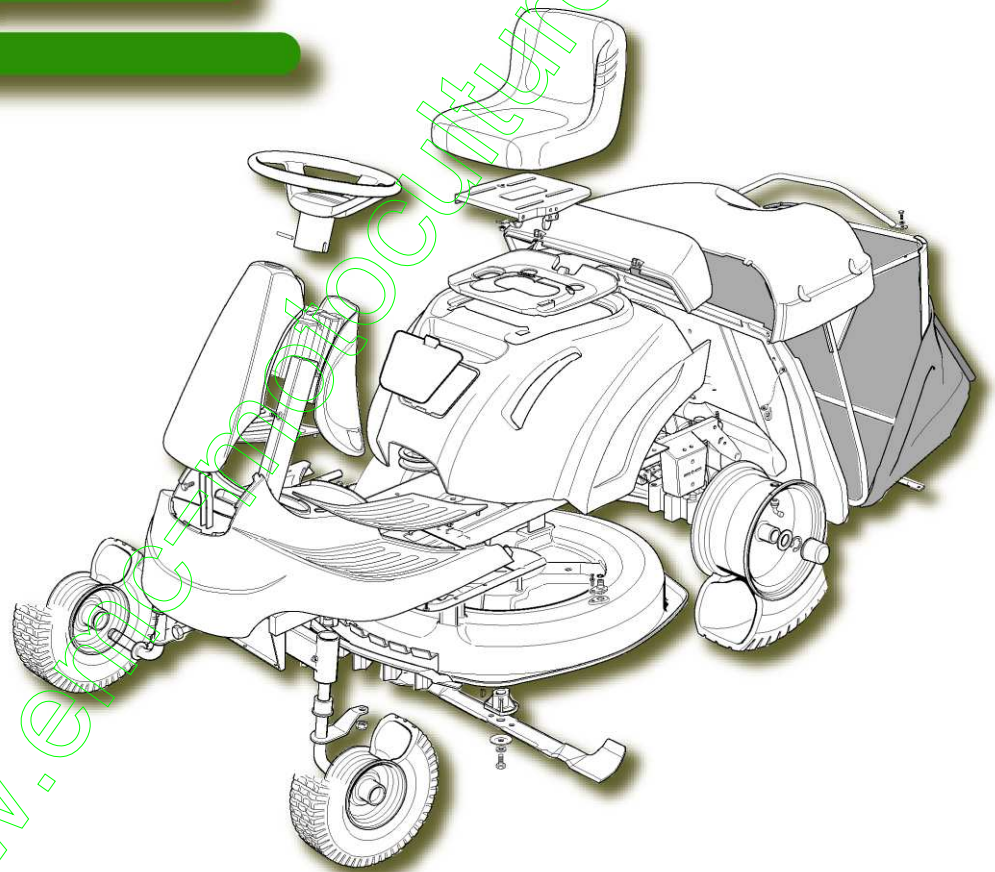

**Catalogo delle parti di ricambio**  
**Spare parts catalogue**  
**Catalogue des pieces de rechange**  
**Ersatzteilkatalog**

# 2006



# 72 72 hydro

CATALOGO DELLE PARTI DI RICAMBIO  
SPARE PARTS CATALOGUE  
CATALOGUE DES PIECES DE RECHANGE  
ERSATZTEILKATALOG

**2006**

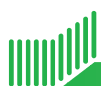

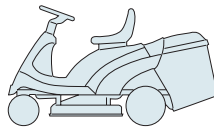

**COME USARE IL CATALOGO**

**HOW TO USE THE CATALOGUE**

**COMMENT UTILISER LE CATALOGUE**

**WIE IST DER KATALOG ZU BENUTZEN**

**1. Generalità**

Questo catalogo contiene tutte le informazioni necessarie per ordinare correttamente i pezzi di ricambio.

**1. General information**

This catalogue contains all the information necessary for correctly ordering spare parts.

**1. Généralités**

Ce catalogue contient toutes les indications nécessaires pour commander correctement les pièces détachées.

**1. Allgemeines**

Dieser Katalog enthält alle Informationen, die für die korrekte Bestellung von Ersatzteilen erforderlich sind.

**2. Struttura del catalogo**

In ogni pagina del catalogo sono riportate le seguenti indicazioni:

**2. Structure of the catalogue**

Each page of the catalogue has these indications:

**2. Structure du catalogue**

Les indications suivantes sont reportées sur chaque page du catalogue:

**2. Aufbau des Katalogs**

Auf jeder Seite des Katalogs sind die folgenden Angaben wiedergegeben:

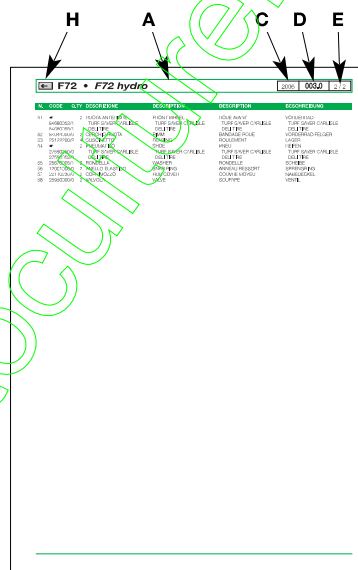
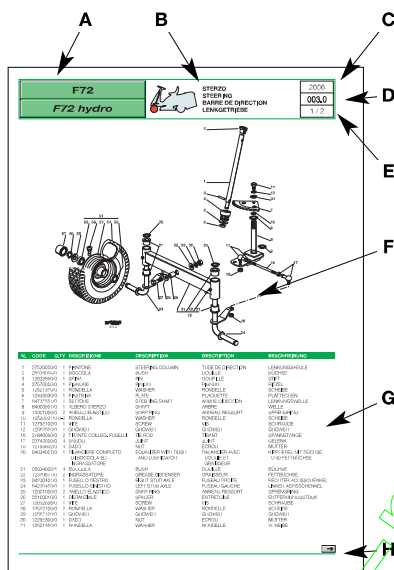

**A.** Macchina o serie di macchine per le quali la pagina è valida.

**A.** Machine or machine series to which the page applies.

**A.** La machine ou la série de machines auxquelles se réfère la page.

**A.** Maschine oder Serie der Maschine, für welche die Seite gültig ist.

**B.** Indicazione del gruppo con la raffigurazione in miniatura della sua collocazione sulla macchina.

**B.** Indication of the unit with a miniature drawing showing its position on the machine.

**B.** L'indication du groupe avec la représentation en miniature de sa position sur la machine.

**B.** Bezeichnung der Gruppe mit einer Miniaturdarstellung ihrer Anbringung auf der Maschine.

**C.** Anno di produzione della macchina a cui si riferisce.

**C.** Year of production of the machine concerned.

**C.** L'année de fabrication de la machine concernée.

**C.** Herstellungsjahr der betreffenden Maschine.

**D.** Numerazione progressiva della tavola, secondo il seguente criterio:

- le prime tre cifre indicano il numero progressivo;
- le eventuali lettere che seguono indicano le diverse versioni alternative di quel gruppo;
- la cifra dopo il punto indica un eventuale aggiornamento nel corso della annualità indicata al punto 3.

**D.** Progressive numbering of the table, arranged as follows:

- the first three numbers are the progressive number;
- any letters that follow will indicate the various alternative versions of that unit;
- the number after the dot is for any updates during the year given at point 3.

**D.** La numérotation progressive du tableau, selon le critère suivant:

- les trois premiers chiffres indiquent le numéro progressif;
- les éventuelles lettres qui suivent indiquent les différentes versions alternatives de ce groupe;
- le chiffre après le point indique l'éventuelle mise à jour effectuée au cours de l'année indiquée au point 3.

**D.** Progressive Numerierung der Tafel nach folgendem Kriterium:

- die ersten drei Ziffern bezeichnen die progressive Nummer;
- die eventuellen Buchstaben, die folgen, bezeichnen die verschiedenen alternativen Versionen dieser Gruppe;
- die Ziffer nach dem Punkt bezeichnet einen eventuellen neueren Stand im Laufe des Jahrgangs, der in Punkt 3 angegeben ist.

Esempio:

**006y.0 =**

006 Trasmissione  
y Idrostatica  
.0 Prima stesura

Example:

**006y.0 =**

006 Transmission  
y Hydrostatic  
.0 First copy

Exemple

**006y.0 =**

006 Transmission  
y Hydrostatique  
.0 Première rédaction

Beispiel:

**006y.0 =**

006 Getriebe  
y Hydrostatisch  
.0 Erste Ausgabe



**E.** Numero della pagina e numero totale delle pagine necessarie per la descrizione del gruppo.

**E.** Page number and total number of pages necessary for the description of the unit.

**E.** Numéro de la page et nombre total des pages nécessaires pour la description du groupe.

**E.** Seitenzahl und Gesamtzahl der Seiten, die für die Beschreibung der Gruppe erforderlich sind.

**F.** Vista esplosa del gruppo.

**F.** Exploded view of the unit.

**F.** Vue éclatée du groupe.

**F.** Explosionszeichnung der Gruppe.

**G.** Descrizione completa dei singoli particolari, con codice e quantità di pezzi.

**G.** Full description of each part, with code number and number of pieces.

**G.** Description complète de chaque élément, avec code et quantité des pièces.

**G.** Vollständige Beschreibung der Einzelteile, mit Kodenummer und Menge der Teile.

**H.** Indicazione della presenza di altre pagine di seguito.

**H.** Indication of additional pages.

**H.** Indication de la présence d'autres pages successives.

**H.** Angabe über die Präsenz weiterer folgender Seiten.

Nelle pagine di seguito, sono riportate nuovamente le indicazioni relative ai punti A - C - D - E - G e H.

The additional pages repeat the indications as at points A - C - D - E - G and H.

Les pages qui suivent reportent, elles aussi, les indications concernant les points A - C - D - E - G et H.

Auf den nachfolgenden Seiten sind die Bezeichnungen, die sich auf die Punkte A - C - D - E - G und H beziehen, erneut wiedergegeben.

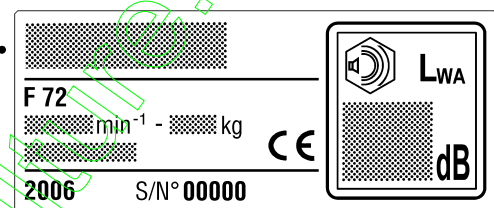
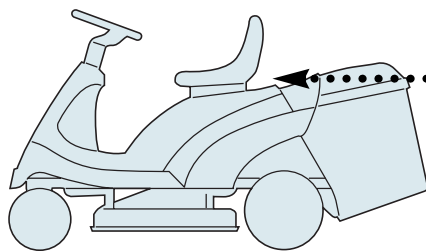

**3. Ordine di ricambi**

**3. Spare parts order**

**3. Commande pièces détachées**

**3. Ersatzteilbestellungen**

Prima di formulare un ordine di ricambi, accertare che il catalogo corrisponda all'anno di costruzione della macchina, riportato sulla targhetta di identificazione.

Before putting in an order for spare parts, make sure that the catalogue is the one applying to the machine's year of manufacture, as shown on the identification plate attached to the machine.

Avant de passer une commande pour des pièces détachées, s'assurer que le catalogue est celui correspondant à l'année de fabrication de la machine reportée sur la plaquette d'identification.

Ehe eine Ersatzteilbestellung geschrieben wird, muß man sich vergewissern, daß der Katalog mit dem Herstellungsjahr der Maschine übereinstimmt, auf dem Kennzeichenschild wiedergegeben.

Ogni ordine di ricambi deve necessariamente contenere:

Each spare parts order must include:

Chaque commande de pièces détachées doit obligatoirement contenir:

Jede Ersatzteilbestellung muß enthalten:

- modello della macchina;
- quantità di pezzi richiesta;
- descrizione (eventuale);
- numero di codice del pezzo;
- destinatario
- mezzo di spedizione.

- the model of the machine;
- the number of parts required;
- description (incidental);
- the code number for the item;
- the destination;
- the method of shipping.

- modèle de la machine;
- quantité de pièces demandée;
- description (éventuelle);
- numéro de code de la pièce;
- le destinataire;
- le moyen de transport.

- Modell der Maschine;
- Menge der angeforderten Teile;
- Bezeichnung (eventuell);
- Artikelnummer des Teils;
- Empfänger;
- Versandart.

**Esempio di ordinazione:**

**An example of an order:**

**Exemple de commande:**

**Beispiel einer Bestellung:**

Su una macchina F72 del 2006, con motore B&S si deve sostituire la protezione del silenziatore. Tale particolare è raffigurato nella tavola **005.0** alla posizione **17**, a cui corrisponde il codice **84598081/0**.

The muffler protection on a F72 machine, produced in 2006 with a B&S engine, must be replaced. This part is shown in table **005.0** in position **17**, and has the code number **84598081/0**.

Sur une machine F72 du 2006, avec moteur B&S, il faut remplacer la protection silencieux. Cette pièce est représentée sur le tableau **005.0** à la position **17**, correspondant au code **84598081/0**.

Auf einer Maschine F72 von 2006, mit Motor B&S muß der Auspuffschutz ersetzt werden. Dieses Einzelteil ist auf der Tafel **005.0** unter der Position **17** dargestellt, der dem Code **84598081/0** entspricht.

L'ordinazione sarà quindi:

The order will therefore be:

La commande sera donc formulée de la façon suivante:

Die Bestellung lautet demnach:

per F72:  
n. 1 protezione cod. 84598081/0 da inviare a .....  
a mezzo .....

for F72:  
1 protection - code 84598081/0 to be sent to .....  
method of shipping .....

pour F72:  
1 protection - code 84598081/0 à envoyer à .....  
par .....

Für F72:  
1 Schutz - Kode 84598081/0 zu versenden an .....  
mit .....

**Nota**

**Note**

**Remarque**

**Anmerkung**

Per le parti non codificate del motore e della trasmissione contrassegnate con (\*), occorre rivolgersi al Costruttore.

For parts of the engine and the transmission without code numbers, marked by (\*), it's necessary to contact the manufacturer.

Pour les pièces non codées du moteur et de la transmission, indiquées avec (\*), il faut s'adresser au Fabricant.

Für die nicht codierten Teile des Motors und des Antriebs, die mit (\*) gekennzeichnet sind, muß man sich an den Hersteller wenden.

**F72**

**F72 hydro**

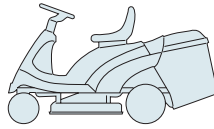

**INDICE DELLE TAVOLE  
INDEX OF TABLES  
SOMMAIRE DES TABLEAUX  
INHALT DER TAFELN**

2006

**000.0**

3 / 4

**TELAIO  
CHASSIS  
CHASSIS  
RAHMENSATZ**

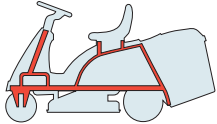

↪ [001](#)

**CARROZZERIA  
BODY  
CARROSSERIE  
KARROSSERIE**

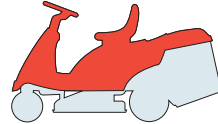

↪ [002](#)

**STERZO  
STEERING  
BARRE DE DIRECTION  
LENKGETRIEBE**

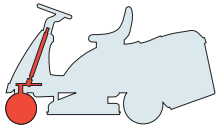

↪ [003](#)

**COMANDO TRASMISSIONE E FRENO  
DRIVE AND BRAKE CONTROLS  
COMMANDE TRANSMISSION ET FREIN  
GETRIEBE UND BREMSE ANTRIEB**

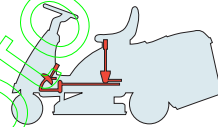

72 ..... ↪ [004M](#)

72 Hydro ..... ↪ [004Y](#)

**MOTORE B&S  
ENGINE B&S  
MOTEUR B&S  
MOTOR B&S**

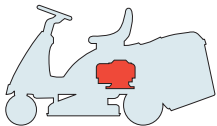

↪ [005](#)

**TRASMISSIONE  
TRANSMISSION  
TRANSMISSION  
GETRIEBE**

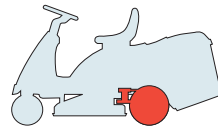

72 ..... ↪ [006M](#)

72 Hydro ..... ↪ [006Y](#)

**SOLLEVAMENTO PIATTO DI TAGLIO  
CUTTING PLATE LIFTING  
SOULEVEMENT PLATEAU DE COUPE  
SCHNEIDWERKZEUG AUFHEBESATZ**

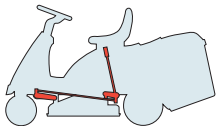

↪ [007](#)

**PIATTO DI TAGLIO (1)  
CUTTING PLATE (1)  
PLATEAU DE COUPE (1)  
SCHNEIDWERKZEUG (1)**

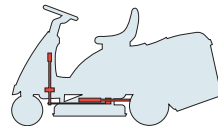

↪ [008](#)



PIATTO DI TAGLIO (2)  
CUTTING PLATE (2)  
PLATEAU DE COUPE (2)  
SCHNEIDWERKZEUG (2)

↔ 009

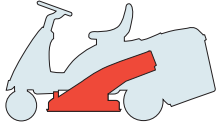

SACCO  
GRASSCATCHER  
BAC  
AUFFANGSACK

↔ 010

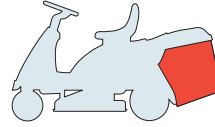

PARTI ELETTRICHE  
ELECTRICAL PARTS  
PARTIES ELECTRIQUES  
ELETRISCHE TEILE

↔ 011

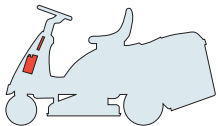

ACCESSORI A RICHIESTA  
OPTIONALS ON REQUEST  
ACCESSOIRES SUR DEMANDE  
ZUBEHOERE NACH ANFRAGE

↔ 012

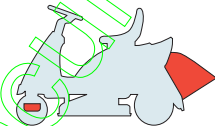

ETICHETTE  
LABELS  
ETIQUETTES  
KLEBZETTEL

↔ 013

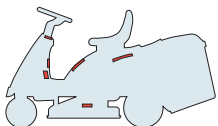

www.emc-motoculture.com

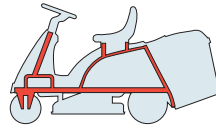
**F72****F72 hydro**
**TELAIO**  
**CHASSIS**  
**CHASSIS**  
**RAHMENSATZ**

2006

**001.0**

1 / 2

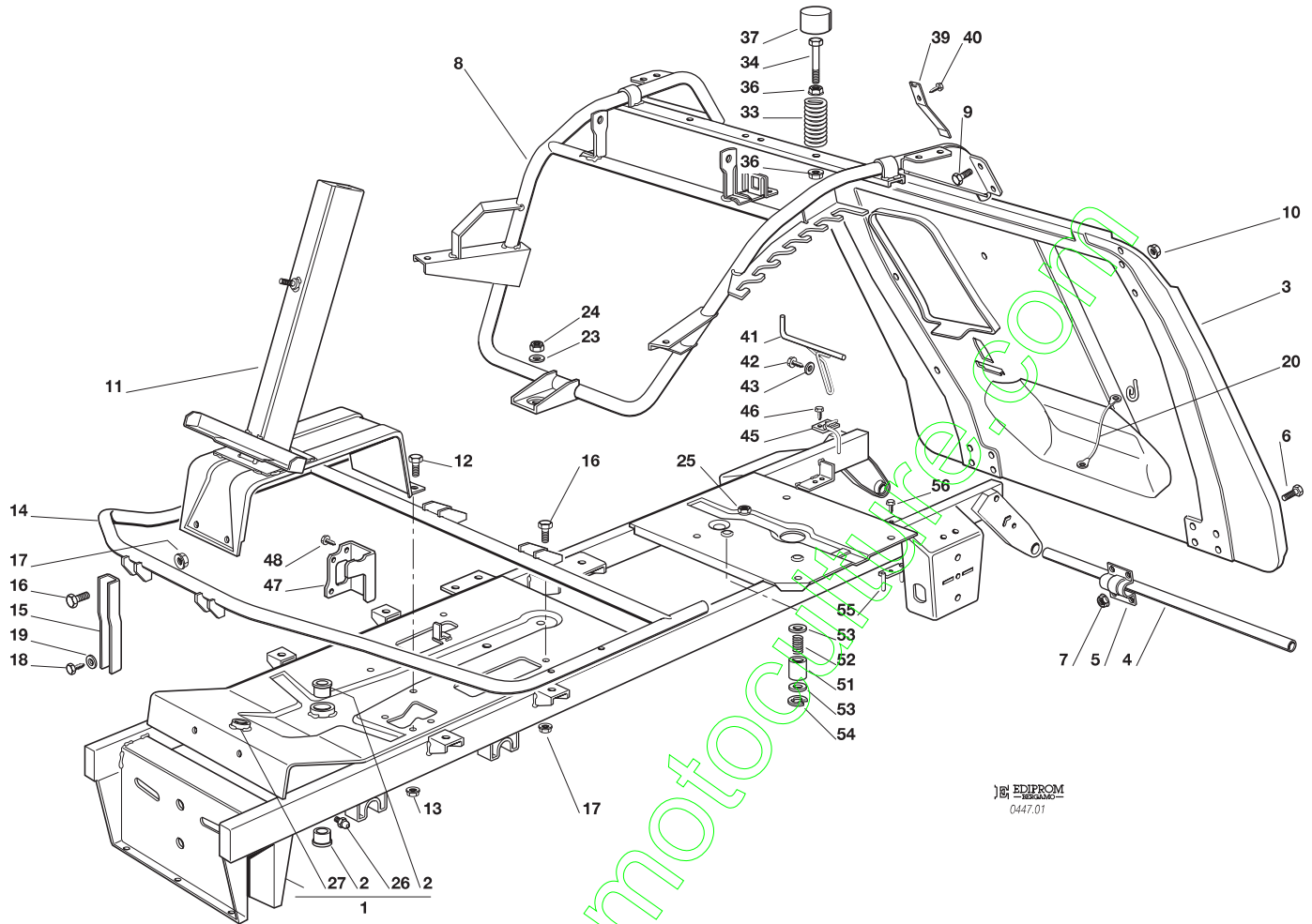
 EPROM  
 0447.01

N.	CODE	Q.TY	DESCRIZIONE	DESCRIPTION	DESCRIPTION	BESCHREIBUNG
1	84801135/0	1	TELAIO	CHASSIS	CHASSIS	RAHMENSATZ
2	25034002/1	2	BOCCOLA	BUSH	DOUILLE	BÜCHSE
3	84545057/3	1	PIASTRA	PLATE	PLAQUE	PLATTE
4	27037000/1	1	PERNO	PIN	PIVOT	BOLZEN
5	25547012/1	2	PIASTRA	PLATE	PLAQUE	PLATTE
6	12791200/0	8	VITE	SCREW	VIS	SCHRAUBE
7	12292102/0	8	DADO	NUT	ECROU	MUTTER
8	84801127/0	1	TELAIO SEDILE	CHASSIS	CHASSIS	RAHMENSATZ
9	12792611/0	4	VITE	SCREW	VIS	SCHRAUBE
10	12293201/0	4	DADO	NUT	ECROU	MUTTER
11	84783027/0	1	SUPPORTO PIANTONE	SUPPORT	SUPPORT	HALTER
12	12792611/0	4	VITE	SCREW	VIS	SCHRAUBE
13	12293201/0	4	DADO	NUT	ECROU	MUTTER
14	84801107/1	1	SUPPORTO PEDANE	FOTTBOARD SUPPORT	SUPPORT MARCHEPIED	FUSSBRETTHALTER
15	27787025/0	2	SUPPORTO	SUPPORT	SUPPORT	HALTER
16	12792611/0	4	VITE	SCREW	VIS	SCHRAUBE
17	12293201/0	4	DADO	NUT	ECROU	MUTTER
18	12734995/0	2	VITE	SCREW	VIS	SCHRAUBE
19	12521331/0	2	RONDELLA	WASHER	RONDELLE	SCHEIBE
20	84040300/0	1	CAVO AGGANCIO	CORD	CORDE	SEIL
23	12523060/0	1	RONDELLA	WASHER	RONDELLE	SCHEIBE
24	12155000/0	1	DADO	NUT	ECROU	MUTTER
25	12500090/0	1	DADO	NUT	ECROU	MUTTER
26	12379511/0	1	INGRASSATORE	GREASE DISPENSER	GRAISSEUR	FETTBÜCHSE
27	25034001/0	1	BRONZINA	BUSH	DOUILLE	BÜCHSE
33	25430575/0	2	MOLLA	SPRING	RESSORT	FEDER
34	27943050/0	2	VITE	SCREW	VIS	SCHRAUBE
36	12293201/0	4	DADO	NUT	ECROU	MUTTER
37	25122000/2	2	CUFFIA	HOOD	PROTECTEUR	SCHUTZKASTEN





N.	CODE	Q.TY	DESCRIZIONE	DESCRIPTION	DESCRIPTION	BESCHREIBUNG
39	27430554/0	1	MOLLA	SPRING	RESSORT	FEDER
40	12735110/0	1	VITE	SCREW	VIS	SCHRAUBE
41	27294001/0	1	GUIDA	GUIDE	GUIDE	FÜHRUNG
42	12735120/0	1	VITE	SCREW	VIS	SCHRAUBE
43	12523040/0	1	RONDELLA	WASHER	RONDELLE	SCHEIBE
45	27294002/0	1	GUIDACINGHIA <i>(mecc.-Peerless)</i>	BELT GUIDE <i>(mech.-Peerless)</i>	GUIDE CURROIRE <i>(mec.-Peerless)</i>	RIEMENFÜHRUNG <i>(mech.-Peerless)</i>
	27294003/0	1	GUIDACINGHIA <i>(mecc.-Dana)</i>	BELT GUIDE <i>(mech.-Dana)</i>	GUIDE CURROIRE <i>(mec.-Dana)</i>	RIEMENFÜHRUNG <i>(mech.-Dana)</i>
46	12735110/0	2	VITE <i>(mecc.)</i>	SCREW <i>(mech.)</i>	VIS <i>(mec.)</i>	SCHRAUBE <i>(mech.)</i>
47	27772095/0	1	STAFFA	CLAMP	ETRIER	BRIDE
48	12735106/0	2	VITE	SCREW	VIS	SCHRAUBE
51	27047012/0	2	BUSSOLA	BUSH	DOUILLE	BÜCHSE
52	27430577/0	2	MOLLA	SPRING	RESSORT	FEDER
53	25670008/1	4	RONDELLA	WASHER	RONDELLE	SCHEIBE
54	12000955/0	2	ANELLO ELASTICO	SNAP RING	ANNEAU RESSORT	SPRENGRING
55	84250053/0	1	GUIDACINGHIA <i>(mecc.)</i>	BELT GUIDE <i>(mech.)</i>	GUIDE DE CURROIRE <i>(mec.)</i>	RIEMENFÜHRUNG <i>(mech.)</i>
56	12735110/0	1	VITE <i>(mecc.)</i>	SCREW <i>(mech.)</i>	VIS <i>(mec.)</i>	SCHRAUBE <i>(mech.)</i>

www.emc-motoculture.com

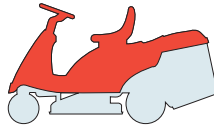

**F72****F72 hydro**
**CARROZZERIA**  
**BODY**  
**CARROSSERIE**  
**KARROSSERIE**

2006

**002.0**

1 / 2

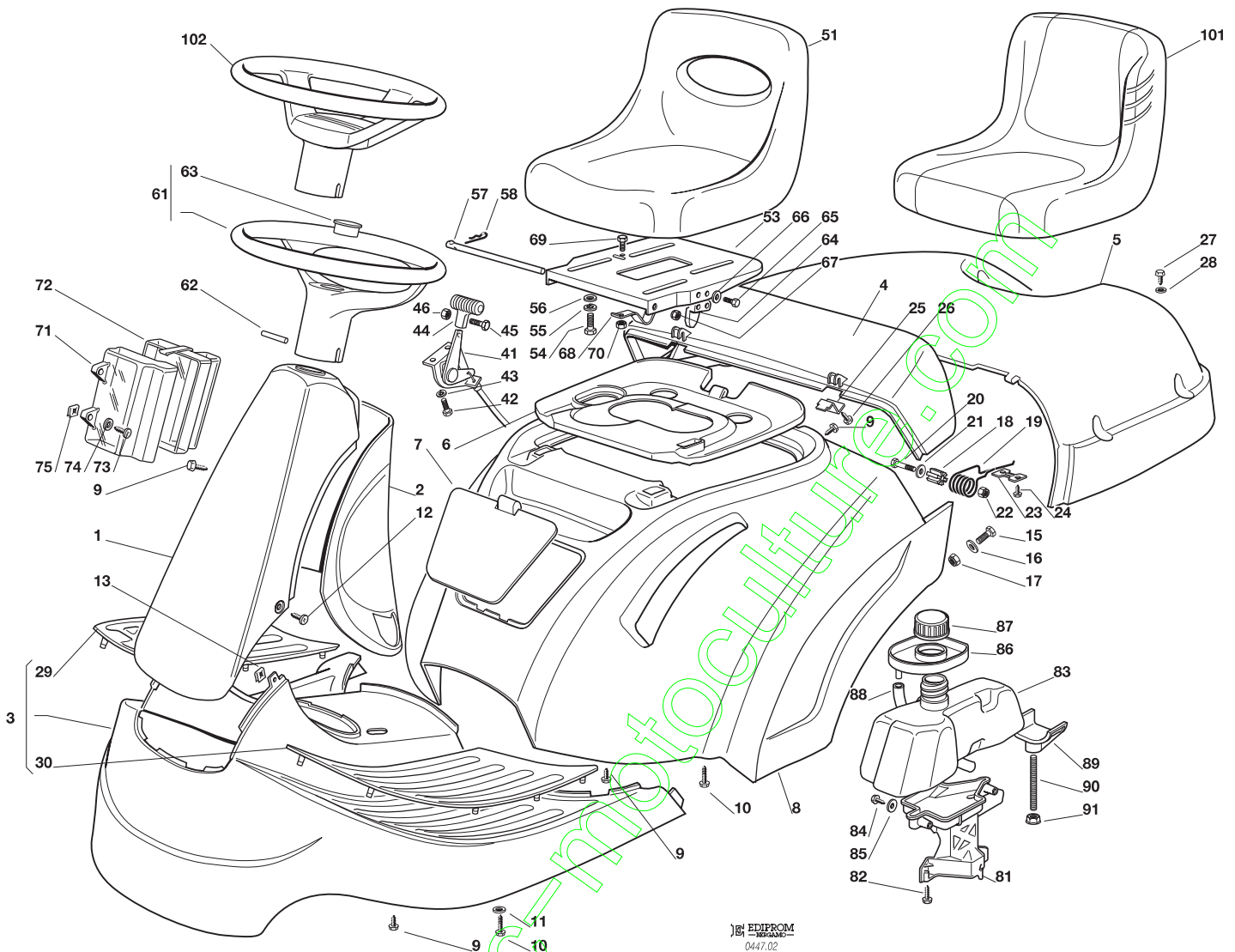
 EDIPROM  
 0447.02

N.	CODE	Q.TY	DESCRIZIONE	DESCRIPTION	DESCRIPTION	BESCHREIBUNG
1	84598064/1 84598065/0 84598076/1 84598067/0	1	PROTEZIONE ANTERIORE ROSSO VERDE ARANCIONE BLU	FRONT COVER RED GREEN ORANGE BLUE	COUVERCLE AVANT ROUGE VERT ORANGE BLEU	VORDERDECKEL ROT GRÜN DUNKELORANGE BLAU
2	27600091/1 27600092/0 27600111/1 27600094/0	1	PROTEZIONE POSTERIORE ROSSO VERDE ARANCIONE BLU	REAR COVER RED GREEN ORANGE BLUE	COUVERCLE ARRIER ROUGE VERT ORANGE BLEU	HINTERDECKEL ROT GRÜN DUNKELORANGE BLAU
3	84110117/2 84110118/1 84110130/1 84110120/1	1	COPERTURA PEDANA ROSSO VERDE ARANCIONE BLU	FOOTBOARD COVER RED GREEN ORANGE BLUE	COUVRE MARCHEPIED ROUGE VERT ORANGE BLEU	FUSSBRETTDECKEL ROT GRÜN DUNKELORANGE BLAU
4	27110302/2 27110317/1 27110353/1 27110319/1	1	COPERTURA SACCO FISSA ROSSO VERDE ARANCIONE BLU	GRASS-CATCHER COVER, FIXED RED GREEN ORANGE BLUE	COUVRE-BAC FIXE ROUGE VERT ORANGE BLEU	FESTER SACKKAPPE ROT GRÜN DUNKELORANGE BLAU
5	27110303/1 27110321/0 27110354/1 27110323/0	1	COPERTURA SACCO MOBILE ROSSO VERDE ARANCIONE BLU	GRASS-CATCHER COVER, MOBILE RED GREEN ORANGE BLUE	COUVRE-BAC MOBILE ROUGE VERT ORANGE BLEU	BEWEGLICHER SACKKAPPE ROT GRÜN DUNKELORANGE BLAU
6	27110306/2	1	COPERTURA MOTORE	ENGINE COVER	COUVRE MOTEUR	MOTORKAPPE
7	27109501/1	1	COPERCHIO ANTERIORE ROSSO	FRONT COVER RED	COUVERCLE AVANT ROUGE	DECKEL ROT



N.	CODE	Q.TY	DESCRIZIONE	DESCRIPTION	DESCRIPTION	BESCHREIBUNG
	27109505/0		VERDE	GREEN	VERT	GRÜN
	27109515/1		ARANCIONE	ORANGE	ORANGE	DUNKELORANGE
	27109507/0		BLU	BLUE	BLEU	BLAU
8	84110100/3	1	COPERTURA RUOTE	WHEELS COVER	COUVRE ROUES	RADENKAPPE
	84110102/2		ROSSO	RED	ROUGE	ROT
	84110128/2		VERDE	GREEN	VERT	GRÜN
	84110104/2		ARANCIONE	ORANGE	ORANGE	DUNKELORANGE
	84110104/2		BLU	BLUE	BLEU	BLAU
8	84110107/3	1	COPERTURA RUOTE (hydro)	WHEELS COVER (hydro)	COUVRE ROUES (hydro)	RADENKAPPE (hydro)
	84110109/2		ROSSO	RED	ROUGE	ROT
	84110129/2		VERDE	GREEN	VERT	GRÜN
	84110111/2		ARANCIONE	ORANGE	ORANGE	DUNKELORANGE
	84110111/2		BLU	BLUE	BLEU	BLAU
9	12735402/0	10	VITE	SCREW	VIS	SCHRAUBE
10	12735410/0	8	VITE	SCREW	VIS	SCHRAUBE
11	12523040/0	4	RONDELLA	WASHER	RONDELLE	SCHEIBE
12	12735598/0	2	VITE	SCREW	VIS	SCHRAUBE
13	12437503/0	2	PIASTRINA	PLATE	PLAQUE	PLATTE
15	12791200/0	2	VITE	SCREW	VIS	SCHRAUBE
16	12523040/0	2	RONDELLA	WASHER	RONDELLE	SCHEIBE
17	12154510/0	2	DADO	NUT	ECROU	MUTTER
18	27047003/0	2	BUSSOLA	BUSH	DOUILLE	BUCHSE
19	27430551/1	2	MOLLA	SPRING	RESSORT	FEDER
20	12691200/0	2	VITE	SCREW	VIS	SCHRAUBE
21	12523070/0	2	RONDELLA	WASHER	RONDELLE	SCHEIBE
22	12155000/0	2	DADO	NUT	ECROU	MUTTER
23	27546001/0	2	PIASTRINA	PLATE	PLAQUE	PLATTE
24	12735402/0	4	VITE	SCREW	VIS	SCHRAUBE
25	27546003/0	2	PIASTRINA	PLATE	PLAQUE	PLATTE
26	12735402/0	2	VITE	SCREW	VIS	SCHRAUBE
27	12729601/1	4	VITE	SCREW	VIS	SCHRAUBE
28	12521331/0	4	RONDELLA	WASHER	RONDELLE	SCHEIBE
29	27110304/0	1	COPRIPEDANA DESTRA	RIGHT FOOTBOARD COVER	COUVRE MARCHEPIED DRO.	RECHTE FUSSBRETTDECKEL
30	27110305/0	1	COPRIPEDANA SINISTRA	LEFT FOOTBOARD COVER	COUVRE MARCHEPIED GAU.	LINKE FUSSBRETTDECKEL
41	84000250/1	1	ACCELERATORE	ACCELERATOR	ACCELERATEUR	GAS ZUG
42	12788512/0	2	VITE	SCREW	VIS	SCHRAUBE
43	12581200/0	2	GROWER	GROWER	GROWER	GROWER
44	25394501/0	1	MANOPOLINA	HANDLE	POIGNE	GRIFF
45	12726388/0	1	VITE	SCREW	VIS	SCHRAUBE
46	12290800/0	1	DADO	NUT	ECROU	MUTTER
51	25722453/1	1	SEDILE	SEAT	SIEGE	SITZ
53	25547033/1	1	PIASTRA	PLATE	PLAQUE	PLATTE
54	12793101/0	4	VITE	SCREW	VIS	SCHRAUBE
55	12583500/0	4	GROWER	GROWER	GROWER	GROWER
56	12523060/0	4	RONDELLA	WASHER	RONDELLE	SCHEIBE
57	27864052/0	1	PERNO	PIN	PIVOT	BOLZEN
58	24487997/0	1	COPPIGLIA	COTTER PIN	GOUPILLE	SPLIT
61	25961201/0	1	VOLANTE	STEERING WHEEL	VOLANT	LENKRAD
62	12620299/0	1	SPINA	PIN	GOUPILLE	STIFT
63	25120230/0	1	TAPPO	CAP	BOUCHON	STOPFEN
64	27063021/1	1	CAMMA	CAM	CAME	NOCKEN
65	12789100/0	2	VITE	SCREW	VIS	SCHRAUBE
66	12523020/0	2	RONDELLA	WASHER	RONDELLE	SCHEIBE
67	12154330/0	2	DADO	NUT	ECROU	MUTTER
68	25430223/2	1	MOLLA	SPRING	RESSORT	FEDER
69	12789000/0	1	VITE	SCREW	VIS	SCHRAUBE
70	12154330/0	1	DADO	NUT	ECROU	MUTTER
71	25600020/0	1	PROTEZIONE SUPERIORE	UPPER GUARD	PROTECTION SUPERIEUR	OBERSCHUTZ
72	25600021/1	1	PROTEZIONE INFERIORE	LOWER GUARD	PROTECTION INFERIEUR	UNTERSCHUTZ
73	12728460/0	2	VITE	SCREW	VIS	SCHRAUBE
74	12521320/0	2	ROSETTA	WASHER	RONDELLE	SCHEIBE
75	12437502/0	2	PIASTRINA	PLATE	PLAQUE	PLÄTTE
81	27787062/0	1	SUPPORTO	SUPPORT	SUPPORT	HALTER
82	12735410/0	3	VITE	SCREW	VIS	SCHRAUBE
83	27733003/1	1	SERBATOIO	TANK	RESERVOIR	TANK
84	12735410/0	2	VITE	SCREW	VIS	SCHRAUBE
85	12523040/0	2	RONDELLA	WASHER	RONDELLE	SCHEIBE
86	27600061/2	1	PROTEZIONE BENZINA	GUARD	PROTECTION	SCHUTZ
87	25795000/1	1	TAPPO	CAP	BOUCHON	TANKVERSCHLUSS
88	25869014/0	1	TUBO	TUBE	TUBE	ROHR
89	27787063/0	1	SUPPORTO	SUPPORT	SUPPORT	HALTER
90	27510118/0	1	PERNO	PIN	PIVOT	BOLZEN
91	12293201/0	2	DADO	NUT	ECROU	MUTTER
101	25722463/0	1	SEDILE COMFORT	SEAT, COMFORT	SIEGE, COMFORT	SITZ, COMFORT
102	25961212/0	1	VOLANTE GRIGIO	STEERING WHEEL, GRAY	VOLANT GRIS	LENKRAD, GRAU

# F72

## F72 hydro

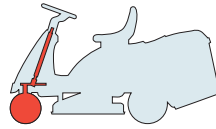

**STERZO  
STEERING  
BARRE DE DIRECTION  
LENKGETRIEBE**

2006

003.0

1 / 2

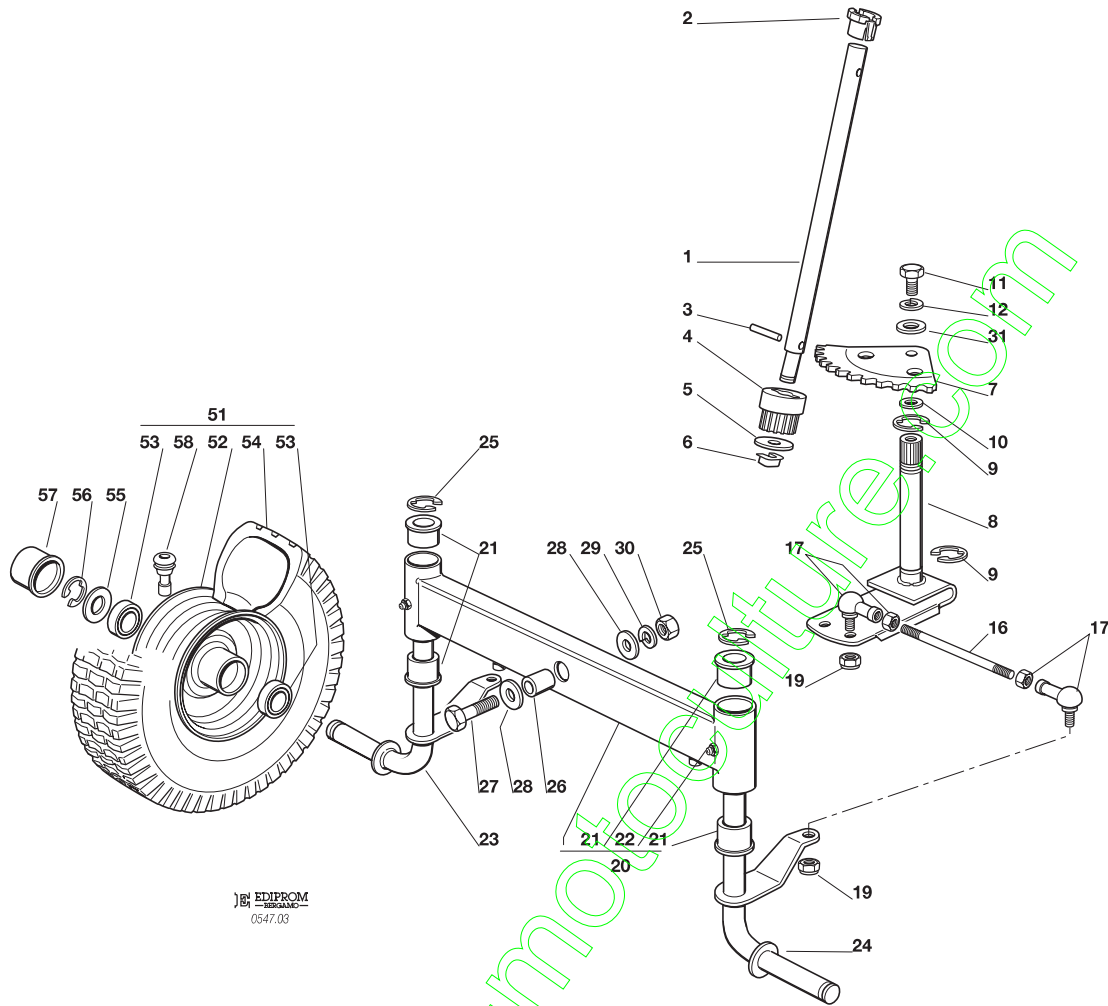

EDIPROM  
0547.03

N.	CODE	Q.TY	DESCRIZIONE	DESCRIPTION	DESCRIPTION	BESCHREIBUNG
1	27520050/0	1	PIANTONE	STEERING COLUMN	TUBE DE DIRECTION	LENKUNGSAEULE
2	25038004/0	1	BOCCOLA	BUSH	DOUILLE	BÜCHSE
3	12622650/0	1	SPINA	PIN	GOUPILLE	STIFT
4	27570050/0	1	PIGNONE	PINION	PIGNON	RITZEL
5	12521370/0	1	RONDELLA	WASHER	RONDELLE	SCHEIBE
6	12436030/0	1	PIASTRINA	PLATE	PLAQUETTE	PLATTECHEN
7	84735551/0	1	SETTORE	STEERING SHAFT	ARBRE DIRECTION	LENKUNGSWELLE
8	84000501/0	1	ALBERO STERZO	SHAFT	ARBRE	WELLE
9	12001000/0	2	ANELLO ELASTICO	SNAP RING	ANNEAU RESSORT	SPRENGRING
10	12520031/0	0-2	RONDELLA	WASHER	RONDELLE	SCHEIBE
11	12793102/0	1	VITE	SCREW	VIS	SCHRAUBE
12	12583500/0	1	GROWER	GROWER	GROWER	GROWER
16	27840050/0	2	TIRANTE COLLEG. FUSELLI	TIE ROD	TIRANT	SPANNSTANGE
17	22746600/0	4	SNODO	JOINT	JOINT	GELENK
19	12156602/0	4	DADO	NUT	ECROU	MUTTER
20	84034057/0	1	BILANCIERE COMPLETO DI BOCCOLA ED INGRASSATORE	EQUALIZER WITH BUSH AND LUBRICATOR	BALANCIER AVEC DOUILLE ET GRAISSEUR	KIPPEBEL MIT BÜCHSE UND FETTBUCHSE
21	25034002/1	4	BOCCOLA	BUSH	DOUILLE	BÜCHSE
22	12379511/0	2	INGRASSATORE	GREASE DISPENSER	GRAISSEUR	FETTBUCHSE
23	84230401/0	1	FUSELLO DESTRO	RIGHT STUB AXLE	FUSEAU DROITE	RECHTER ACHSSCHENKEL
24	84230403/0	1	FUSELLO SINISTRO	LEFT STUB AXLE	FUSEAU GAUCHE	LINKER ACHSSCHENKEL
25	12001000/0	2	ANELLO ELASTICO	SNAP RING	ANNEAU RESSORT	SPRENGRING
26	25160016/0	1	DISTANZIALE	SPACER	ENTRETOISE	ENTFERNUNGSSTÜCK
27	12692695/0	1	VITE	SCREW	VIS	SCHRAUBE
28	12523100/0	2	RONDELLA	WASHER	RONDELLE	SCHEIBE
29	12587100/0	1	GROWER	GROWER	GROWER	GROWER
30	12295300/0	1	DADO	NUT	ECROU	MUTTER
31	12521350/0	1	RONDELLA	WASHER	RONDELLE	SCHEIBE





N.	CODE	Q.TY	DESCRIZIONE	DESCRIPTION	DESCRIPTION	BESCHREIBUNG
51	84680052/1 84680055/1	2	RUOTA ANTERIORE TURF SAVER CARLISLE DELI TIRE	FRONT WHEEL TURF SAVER CARLISLE DELI TIRE	ROUE AVANT TURF SAVER CARLISLE DELI TIRE	VORDERRAD TURF SAVER CARLISLE DELI TIRE
52	84044000/0	2	CERCHIO RUOTA	RIMM	BANDAGE ROUE	VORDERRAD FELGER
53	25122200/2	4	CUSCINETTO	BEARING	ROULEMENT	LAGER
54	27590050/0 27590052/0	2	PNEUMATICO TURF SAVER CARLISLE DELI TIRE	SHOE TURF SAVER CARLISLE DELI TIRE	PNEU TURF SAVER CARLISLE DELI TIRE	REIFEN TURF SAVER CARLISLE DELI TIRE
55	25670005/1	2	RONDELLA	WASHER	RONDELLE	SCHEIBE
56	12001000/0	2	ANELLO ELASTICO	SNAP RING	ANNEAU RESSORT	SPRENGRING
57	22110230/0	2	COPRIMOZZO	HUB COVER	COUVRE MOYEU	NABEDECKEL
58	25950000/0	2	VALVOLA	VALVE	SOUPAPE	VENTIL

www.emc-motoculture.com

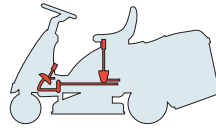
**F72***F72 hydro*

COMANDO FRENO E COMANDO CAMBIO  
 BRAKE AND GEARBOX CONTROLS  
 COMMANDE FREIN ET BOITE DE VITESSE  
 BREMSE UND WECHSEL ANTRIEB

2006

**004M.0**

1 / 2

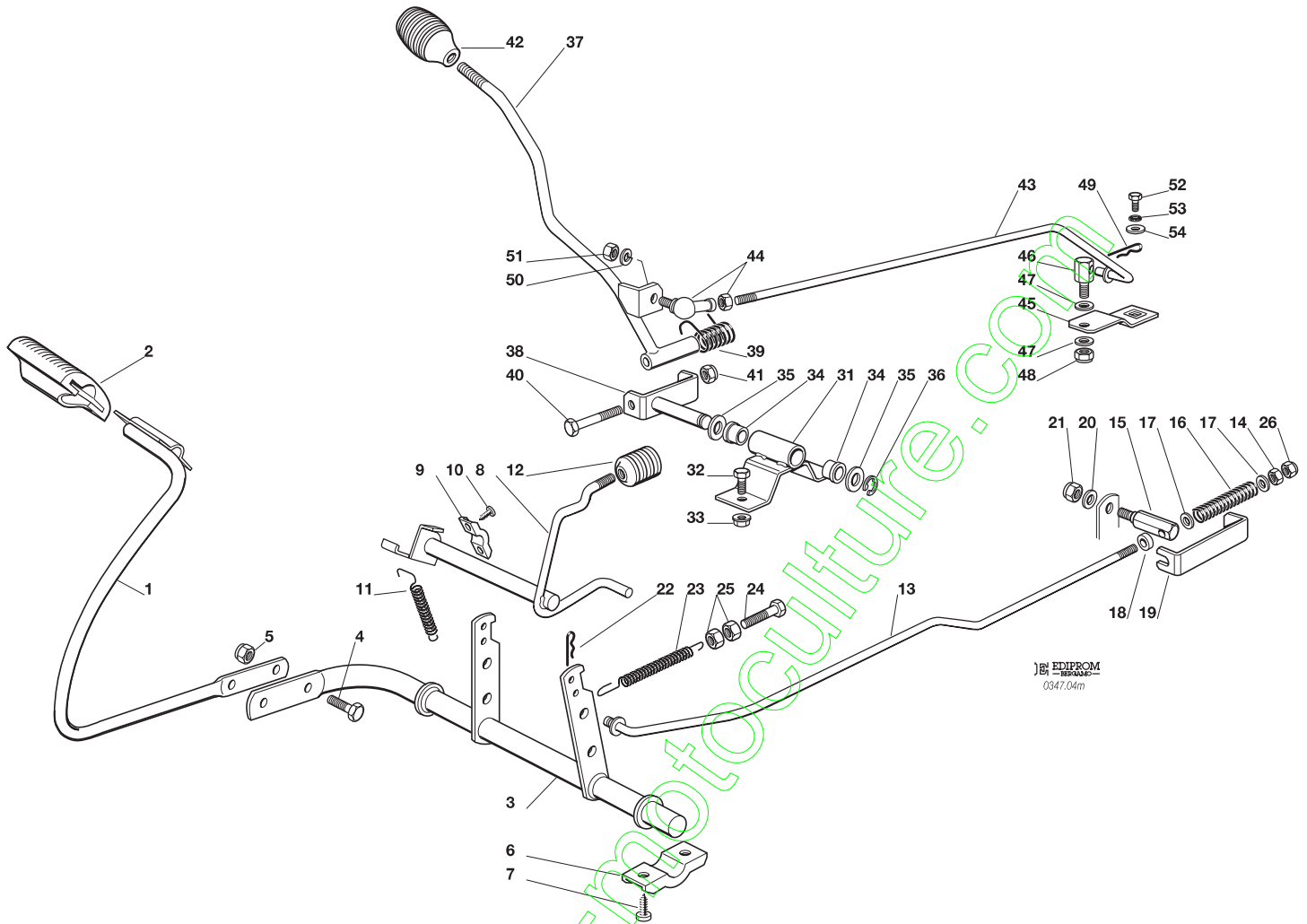

EDIPROM  
 0347.04m

N.	CODE	Q.TY	DESCRIZIONE	DESCRIPTION	DESCRIPTION	BESCHREIBUNG
1	84503001/0	1	PEDALE	PEDAL	PEDAL	PEDAL
2	25110269/0	1	COPRISTAFFA	CLAMP COVER	COUVRE ETRIER	BRIDECKEL
3	84001015/1	1	ASSE FRENO	AXLE	AXE	ACHSE
4	12793301/0	2	VITE	SCREW	VIS	SCHRAUBE
5	12155000/0	2	DADO	NUT	ECROU	MUTTER
6	27546015/1	2	PIASTRINA	PLATE	PLAQUE	PLATTE
7	12731350/0	4	VITE	SCREW	VIS	SCHRAUBE
8	84001011/2	1	ASSE FRENO	AXLE	AXE	ACHSE
9	25547049/0	2	PIASTRINA	PLATE	PLAQUE	PLATTE
10	12731601/0	4	VITE	SCREW	VIS	SCHRAUBE
11	27430552/0	1	MOLLA	SPRING	RESSORT	FEDER
12	27395050/1	1	MANOPOLA	KNOB	POIGNEE	KNOPF
13	27034060/0	1	ASTA	ROD	BARRE	STANGE
14	12293200/0	1	DADO	NUT	ECROU	MUTTER
15	27510115/0	1	PERNO	PIN	PIVOT	BOLZEN
16	25430236/0	1	MOLLA	SPRING	RESSORT	FEDER
17	12521350/0	2	ROSETTA	WASHER	RONDELLE	SCHEIBE
18	22171001/0	1	DISTANZIALE	SPACER	ENTRETOISE	ENTFERNUNGSSTÜCK
19	25774275/0	1	STAFFA	CLAMP	ETRIER	BRIDE
20	12523050/0	1	ROSETTA	WASHER	RONDELLE	SCHEIBE
21	12154510/0	1	DADO	NUT	ECROU	MUTTER
22	24487997/0	1	COPPIGLIA	COTTER PIN	GOUILLE	SPLIT
23	25430220/0	1	MOLLA	SPRING	RESSORT	FEDER
24	22943005/0	1	VITE	SCREW	VIS	SCHRAUBE
25	12293200/0	2	DADO	NUT	ECROU	MUTTER
26	12155000/0	1	DADO	NUT	ECROU	MUTTER
31	84773551/0	1	STAFFA	CLAMP	ETRIER	BRIDE
32	12793102/0	2	VITE	SCREW	VIS	SCHRAUBE
33	12293201/0	2	DADO	NUT	ECROU	MUTTER





N.	CODE	Q.TY	DESCRIZIONE	DESCRIPTION	DESCRIPTION	BESCHREIBUNG
34	27047002/0	2	BUSSOLA	BUSHING	DOUILLE	LAGER
35	12521370/0	2	RONDELLA	WASHER	RONDELLE	SCHEIBE
36	12608600/0	1	SEEGER	SEEGER	SEEGER	SEEGER
37	84317051/2	1	LEVA	GEARSHIFT	LEVIER	HEBEL
38	84773553/0	1	STAFFA	CLAMP	ETRIER	BRIDE
39	25430226/0	1	MOLLA	SPRING	RESSORT	FEDER
40	12692050/0	1	VITE	SCREW	VIS	SCHRAUBE
41	12155000/0	1	DADO	NUT	ECROU	MUTTER
42	82394508/0	1	MANOPOLA	KNOB	POIGNEE	WECHSEL
43	27034052/0	1	ASTA <b>(Peerless)</b>	ROD <b>(Peerless)</b>	BARRE <b>(Peerless)</b>	STANGE <b>(Peerless)</b>
	27034080/0	1	ASTA <b>(Dana)</b>	ROD <b>(Dana)</b>	BARRE <b>(Dana)</b>	STANGE <b>(Dana)</b>
44	22746601/0	1	SNODO	JOINT	JOINT	GELENK
45	27315077/0	1	LEVA <b>(Peerless)</b>	GEARSHIFT <b>(Peerless)</b>	LEVIER <b>(Peerless)</b>	HEBEL <b>(Peerless)</b>
	27315109/0	1	LEVA <b>(Dana)</b>	GEARSHIFT <b>(Dana)</b>	LEVIER <b>(Dana)</b>	HEBEL <b>(Dana)</b>
46	25510040/1	1	PERNO	PIN	PIVOT	BOLZEN
47	25670011/0	2	RONDELLA	WASHER	RONDELLE	SCHEIBE
48	12155000/0	1	DADO	NUT	ECROU	MUTTER
49	24487997/0	1	COPPIGLIA	COTTER PIN	GOUPILLE	SPLIT
50	12583500/0	1	GROWER	GROWER	GROWER	GROWER
51	12293200/0	1	DADO	NUT	ECROU	MUTTER
52	12735520/0	1	VITE	SCREW	VIS	SCHRAUBE
53	12540040/0	1	RONDELLA	WASHER	RONDELLE	SCHEIBE
54	22680009/0	1	RONDELLA	WASHER	RONDELLE	SCHEIBE

www.emc-motoculture.com

F72

F72 hydro

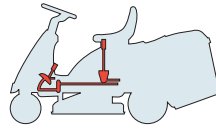

COMANDO TRASMISSIONE E FRENO  
DRIVE AND BRAKE CONTROLS  
COMMANDE TRANSMISSION ET FREIN  
GETRIEBE UND BREMSE ANTRIEB

2006

004Y.0

1 / 2

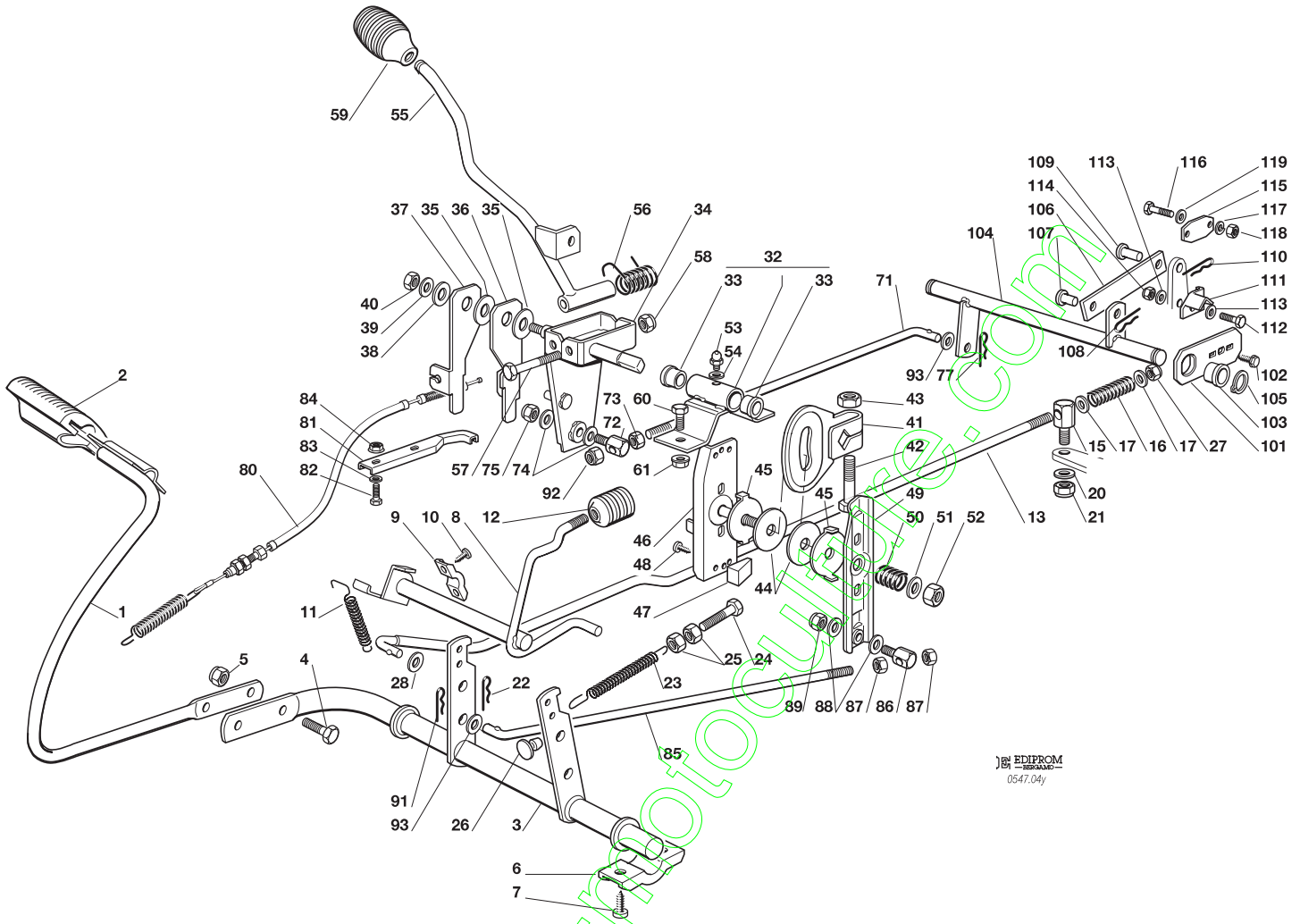

EBIPROM  
0547.04y

N.	CODE	Q.TY	DESCRIZIONE	DESCRIPTION	DESCRIPTION	BESCHREIBUNG
1	84503001/0	1	PEDALE	PEDAL	PEDAL	PEDAL
2	25110267/0	1	COPRISTAFFA	CLAMP COVER	COUVRE ETRIER	BRIDEDECKEL
3	84001015/1	1	ASSE FRENO	AXLE	AXE	ACHSE
4	12793301/0	2	VITE	SCREW	VIS	SCHRAUBE
5	12155000/0	2	DADO	NUT	ECROU	MUTTER
6	27546015/1	2	PIASTRINA	PLATE	PLAQUE	PLATTE
7	12731350/0	4	VITE	SCREW	VIS	SCHRAUBE
8	84001011/2	1	ASSE FRENO	AXLE	AXE	ACHSE
9	25547049/0	2	PIASTRINA	PLATE	PLAQUE	PLATTE
10	12731601/0	4	VITE	SCREW	VIS	SCHRAUBE
11	27430552/0	1	MOLLA	SPRING	RESSORT	FEDER
12	27395050/1	1	MANOPOLA	KNOB	POIGNEE	KNOPF
13	27034070/0	1	ASTA	ROD	BARRE	STANGE
15	25510067/1	1	PERNO	PIN	PIVOT	BOLZEN
16	25430236/0	1	MOLLA	SPRING	RESSORT	FEDER
17	12521360/0	2	ROSETTA	WASHER	RONDELLE	SCHEIBE
20	12523050/0	1	ROSETTA	WASHER	RONDELLE	SCHEIBE
21	12155000/0	1	DADO	NUT	ECROU	MUTTER
22	24487997/0	1	COPPIGLIA	COTTER PIN	GOUILLE	SPLIT
23	25430210/0	1	MOLLA	SPRING	RESSORT	FEDER
24	22943005/0	1	VITE	SCREW	VIS	SCHRAUBE
25	12293200/0	2	DADO	NUT	ECROU	MUTTER
26	27275000/0	1	GOMMINO	GROMMET	CAOUTCHOUC	GUMMI
27	12156602/0	1	DADO	NUT	ECROU	MUTTER
28	25670011/0	1	ROSETTA	WASHER	RONDELLE	SCHEIBE
32	84773568/0	1	STAFFA CON BUSSOLE	BRACKET WITH BUSSH	INGSETRIER AVEC DOUILLES	BRIDE MIT LAGERN
33	27045080/0	2	BUSSOLA	BUSHING	DOUILLE	LAGER
34	84773561/0	1	LEVA	LEVER	LEVIER	HEBEL
35	22672151/0	2	RONDELLA	WASHER	RONDELLE	SCHEIBE



N.	CODE	Q.TY	DESCRIZIONE	DESCRIPTION	DESCRIPTION	BESCHREIBUNG
36	27772101/0	1	STAFFA	CLAMP	ETRIER	BRIDE
37	27772103/0	1	STAFFA	CLAMP	ETRIER	BRIDE
38	22672152/0	1	RONDELLA	WASHER	RONDELLE	SCHEIBE
39	12523060/0	1	RONDELLA	WASHER	RONDELLE	SCHEIBE
40	12155010/0	1	DADO	NUT	ECROU	MUTTER
41	27734055/0	1	SETTORE	SECTOR	SECTEUR	SEKTOR
42	12794900/0	1	VITE	SCREW	VIS	SCHRAUBE
43	12155020/0	1	DADO	NUT	ECROU	MUTTER
44	27158000/0	2	DISCO	PLATE	DISQUE	SCHEIBE
45	27670053/0	2	RONDELLA	WASHER	RONDELLE	SCHEIBE
46	84773565/0	1	STAFFA	CLAMP	ETRIER	BRIDE
47	27063020/0	2	CAMMA	CAM	CAME	NOCKEN
48	12735110/0	2	VITE	SCREW	VIS	SCHRAUBE
49	84773563/0	1	LEVA	LEVER	LEVIER	HEBEL
50	27430560/0	1	MOLLA	SPRING	RESSORT	FEDER
51	25670008/1	1	RONDELLA	WASHER	RONDELLE	SCHEIBE
52	12155020/0	1	DADO	NUT	ECROU	MUTTER
53	12379511/0	1	INGRASSATORE	GREASE DISPENSER	GRAISSEUR	FETTBUCHSE
54	12521330/0	1	RONDELLA	WASHER	RONDELLE	SCHEIBE
55	84317051/2	1	LEVA	GEARSHIFT	LEVIER	HEBEL
56	25430226/0	1	MOLLA	SPRING	RESSORT	FEDER
57	12692050/0	1	VITE	SCREW	VIS	SCHRAUBE
58	12155000/0	1	DADO	NUT	ECROU	MUTTER
59	82394508/0	1	MANOPOLA	KNOB	POIGNEE	WECHSEL
60	12793102/0	2	VITE	SCREW	VIS	SCHRAUBE
61	12293201/0	2	DADO	NUT	ECROU	MUTTER
71	27034071/0	1	ASTA	ROD	BARRE	STANGE
72	25510040/1	1	PERNO	PIN	PIVOT	BOLZEN
73	12293200/0	1	DADO	NUT	ECROU	MUTTER
74	25670011/0	2	RONDELLA	WASHER	RONDELLE	SCHEIBE
75	12155010/0	1	DADO	NUT	ECROU	MUTTER
77	24487997/0	1	COPPIGLIA	COTTER PIN	GOUPILLE	SPLIT
80	84207101/1	1	FILO	WIRE	FIL	KABEL
81	27772105/0	1	STAFFA	CLAMP	ETRIER	BRIDE
82	12791400/0	2	VITE	SCREW	VIS	SCHRAUBE
83	12521330/0	2	RONDELLA	WASHER	RONDELLE	SCHEIBE
84	12292102/0	2	DADO	NUT	ECROU	MUTTER
85	27034074/0	1	ASTA	ROD	BARRE	STANGE
86	25510040/1	1	PERNO	PIN	PIVOT	BOLZEN
87	12293200/0	2	DADO	NUT	ECROU	MUTTER
88	25670011/0	2	RONDELLA	WASHER	RONDELLE	SCHEIBE
89	12155010/0	1	DADO	NUT	ECROU	MUTTER
91	24487997/0	1	COPPIGLIA	COTTER PIN	GOUPILLE	SPLIT
92	12155000/0	1	DADO	NUT	ECROU	MUTTER
93	25670011/0	2	RONDELLA	WASHER	RONDELLE	SCHEIBE
101	27546047/0	2	PIASTRINA	PLATE	PLAQUE	PLATTE
102	12735121/0	2	VITE	SCREW	VIS	SCHRAUBE
103	25040614/0	2	BUSSOLA	BUSH	DOUILLE	BÜCHSE
104	84001023/0	1	ASSE	AXLE	AXE	ACHSE
105	12608900/0	2	SEEGER	SEEGER	SEEGER	SEEGER
106	27034073/0	1	ASTA	ROD	BARRE	STANGE
107	27510111/0	1	PERNO	PIN	PIVOT	BOLZEN
108	24487997/0	1	COPPIGLIA	COTTER PIN	GOUPILLE	SPLIT
109	27510110/0	1	PERNO	PIN	PIVOT	BOLZEN
110	24487997/0	1	COPPIGLIA	COTTER PIN	GOUPILLE	SPLIT
111	27063022/0	1	CAMMA	CAM	CAME	NOCKEN
112	12791400/0	1	VITE	SCREW	VIS	SCHRAUBE
113	12521330/0	2	RONDELLA	WASHER	RONDELLE	SCHEIBE
114	12154510/0	1	DADO	NUT	ECROU	MUTTER
115	27546019/0	1	PIASTRINA	PLATE	PLAQUE	PLATTE
116	12735602/0	2	VITE	SCREW	VIS	SCHRAUBE
117	12581100/0	2	GROWER	GROWER	GROWER	GROWER
118	12290791/0	2	DADO	NUT	ECROU	MUTTER
119	12540020/0	2	RONDELLA	WASHER	RONDELLE	SCHEIBE

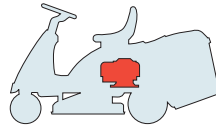

**F72****F72 hydro**
**MOTORE  
ENGINE  
MOTEUR  
MOTOR  
B&S**
**BRIGGS & STRATTON**

2006

**005.0**

1 / 1

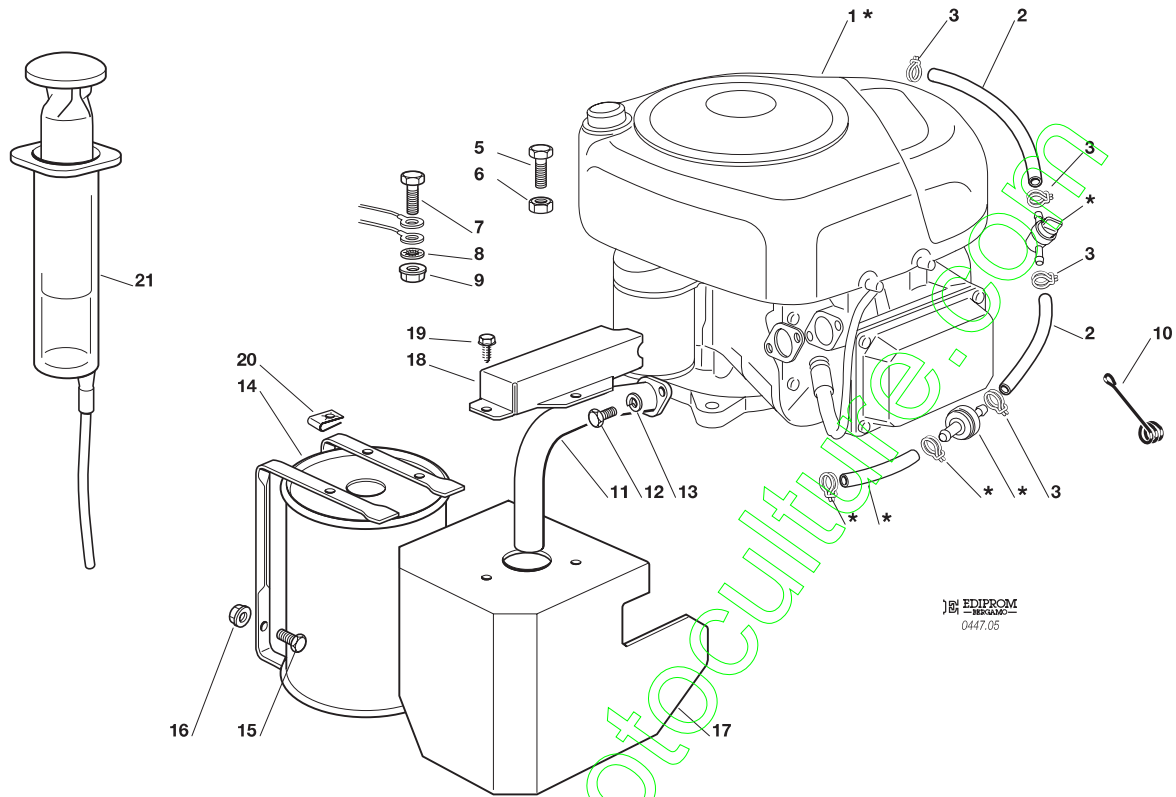
**EDIPROM**  
0447.05

N.	CODE	Q.TY	DESCRIZIONE	DESCRIPTION	DESCRIPTION	BESCHREIBUNG
1*	-	1	MOTORE	ENGINE	MOTEUR	MOTOR
2	25869035/1	2	TUBO	TUBE	TUBE	ROHR
3	18375051/1	4	FASCETTA	FAIR LED	FIXATION DE CABLE	KABELBEFESTIGUNG
5	12691100/0	3	VITE	SCREW	VIS	SCHRAUBE
6	12154210/0	3	DADO	NUT	ECROU	MUTTER
7	12691115/0	1	VITE	SCREW	VIS	SCHRAUBE
8	12540260/0	1	RONDELLA	WASHER	RONDELLE	SCHEIBE
9	12154210/0	1	DADO	NUT	ECROU	MUTTER
10	25430239/1	1	MOLLA	SPRING	RESSORT	FEDER
11	18738225/0	1	RACCORDO SCARICO	EXHAUST CONNECTION	CONNEXION ECHAPPEMENT	AUSPUFFANSCHLUSS
12	12737450/0	2	VITE	SCREW	VIS	SCHRAUBE
13	12583500/0	2	GROWER	GROWER	GROWER	GROWER
14	82750006/1	1	SILENZIATORE	MUFFLER	SILENCEUX	AUSPUFF
15	12793102/0	2	VITE	SCREW	VIS	SCHRAUBE
16	12154210/0	2	DADO	NUT	ECROU	MUTTER
17	84598081/0	1	PROTEZIONE SILENZIATORE	MUFFLER PROTECTION	PROTECTION SILENCEUX	AUSPUFFSCHUTZ
18	27600137/0	1	PROTEZIONE	PROTECTION	PROTECTION	SCHUTZ
19	12729601/1	3	VITE	SCREW	VIS	SCHRAUBE
20	12437504/0	3	PIASTRINA	PLATE	PLAQUE	PLATTE
21	18718000/0	1	SIRINGA	SYRINGE	SERINGUE	SPRITZE

PER LA SOSTITUZIONE DELLE PARTI CONTRASSEGNALE CON «\*» RIVOLGERSI AL SERVIZIO ASSISTENZA DEL COSTRUTTORE DEL MOTORE.  
 TO REPLACE THE PARTS MARKED «\*» SEEK ASSISTANCE FROM THE ENGINE MANUFACTURER'S AFTER SALES SERVICE.  
 POUR LE REMPLACEMENT DES PIÈCES MARQUÉES AVEC «\*» S'ADRESSER AU SERVICE APRÈS VENTES DU CONSTRUCTEUR DU MOTEUR.  
 ZUM AUSTAUSCH DER MIT «\*» GEKENNZEICHNETEN TEILE, WENDEN SIE SICH AN DEN KUNDENDIENST DES HERSTELLERS DES MOTOR.

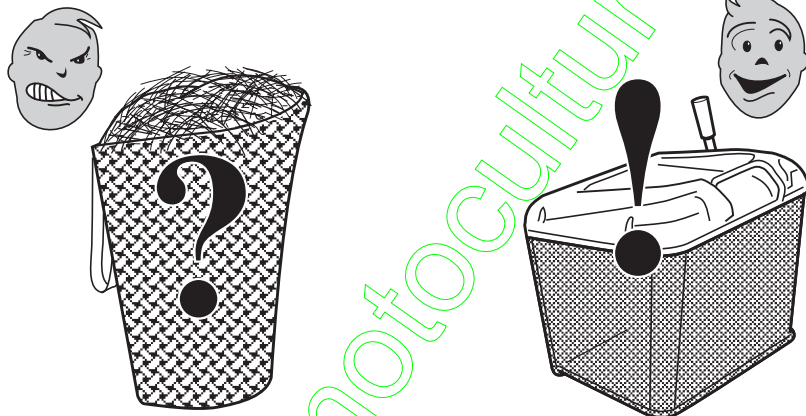

**USARE SOLO RICAMBI ORIGINALI!**  
**USE ONLY GENUINE SPARE PARTS!**  
**UTILISER DES PIÈCES DE RECHANGE D'ORIGINE!**  
**NUR ORIGINALERSATZTEILE VERWENDEN!**

[www.ericmotoculture.com](http://www.ericmotoculture.com)

# F72

## F72 hydro

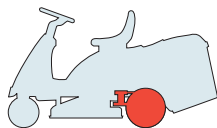

TRASMISSIONE  
TRANSMISSION  
TRANSMISSION  
GETRIEBE

2006

006M.0

1 / 2

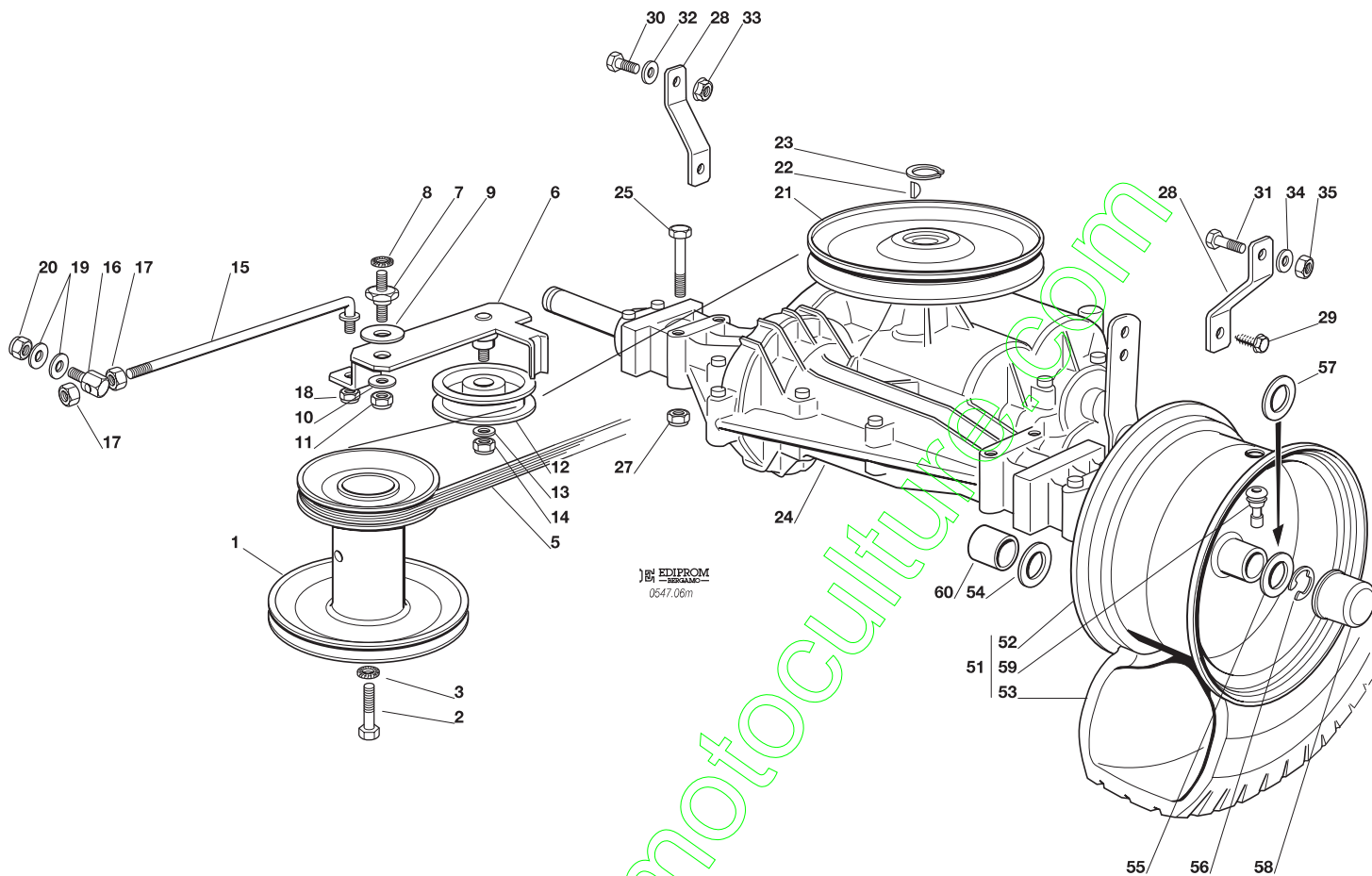

N.	CODE	Q.TY	DESCRIZIONE	DESCRIPTION	DESCRIPTION	BESCHREIBUNG
1	27604003/1	1	PULEGGIA	PULLEY	POULIE	RIEMENSCHIBE
2	12737310/0	1	VITE	SCREW	VIS	SCHRAUBE
3	12543000/0	1	ROSETTA	WASHER	RONDELLE	SCHEIBE
5	35061400/0	1	CINGHIA	BELT	COURROIE	RIEMEN
6	84317055/1	1	LEVA	LEVER	LEVIER	HEBEL
7	27510096/0	1	PERNO	PIN	PIVOT	BOLZEN
8	12540260/0	1	RONDELLA	WASHER	RONDELLE	SCHEIBE
9	22672151/0	1	RONDELLA	WASHER	RONDELLE	SCHEIBE
10	25670011/0	1	RONDELLA	WASHER	RONDELLE	SCHEIBE
11	12155010/0	1	DADO	NUT	ECROU	MUTTER
12	25601554/0	1	PULEGGIA	PULLEY	POULIE	RIEMENSCHIBE
13	12523060/0	1	RONDELLA	WASHER	RONDELLE	SCHEIBE
14	12155000/0	1	DADO	NUT	ECROU	MUTTER
15	27034054/0	1	TIRANTE	TIE ROD	TIRANT	SPANNSTANGE
16	25510040/1	1	PERNO	PIN	PIVOT	BOLZEN
17	12293200/0	2	DADO	NUT	ECROU	MUTTER
18	12155000/0	1	DADO	NUT	ECROU	MUTTER
19	25670011/0	2	RONDELLA	WASHER	RONDELLE	SCHEIBE
20	12155000/0	1	DADO	NUT	ECROU	MUTTER
21	82601503/0	1	PULEGGIA	PULLEY	POULIE	RIEMENSCHIBE
22	12139430/0	1	LINGUETTA	KEY	CLAVETTE	KEIL
23	12608950/0	1	ANELLO ELASTICO	SNAP RING	ANNEAU RESSORT	SPRENGRING
24*	18400915/2	1	ASSE POSTERIORE	REAR AXLE	AXE ARRIERE	HINTERACHSE
			<b>Tecumseh-Peerless MST 205-541 E</b>	<b>Tecumseh-Peerless MST 205-541 E</b>	<b>Tecumseh-Peerless MST 205-541 E</b>	<b>Tecumseh-Peerless MST 205-541 E</b>
*	18400917/0	1	ASSE POSTERIORE (Dana)	REAR AXLE (Dana)	AXE ARRIERE (Dana)	HINTERACHSE (Dana)
25	12691800/0	4	VITE (Peerless)	SCREW (Peerless)	VIS (Peerless)	SCHRAUBE (Peerless)
	12691900/0	4	VITE (Dana)	SCREW (Dana)	VIS (Dana)	SCHRAUBE (Dana)
27	12154210/0	4	DADO	NUT	ECROU	MUTTER
28	27772067/0	2	STAFFA	CLAMP	ETRIER	BRIDE
29	12735150/0	2	VITE	SCREW	VIS	SCHRAUBE
30	12793102/0	1	VITE	SCREW	VIS	SCHRAUBE



N.	CODE	Q.TY	DESCRIZIONE	DESCRIPTION	DESCRIPTION	BESCHREIBUNG
31	12793301/0	1	VITE	SCREW	VIS	SCHRAUBE
32	12523060/0	1	RONDELLA	WASHER	RONDELLE	SCHEIBE
33	12293201/0	1	DADO	NUT	ECROU	MUTTER
34	12521350/0	1	RONDELLA	WASHER	RONDELLE	SCHEIBE
35	12155000/0	1	DADO	NUT	ECROU	MUTTER
51	84680050/1	2	RUOTA POSTERIORE TURF SAVER CARLISLE	REAR WHEEL TURF SAVER CARLISLE	ROUE ARRIERE TURF SAVER CARLISLE	HINTERRAD TURF SAVER CARLISLE
	84680053/1		DELI TIRE	DELI TIRE	DELI TIRE	DELI TIRE
52	84044001/0	2	CERCHIO RUOTA	RIMM	BANDAGE ROUE	HINTRERRAD FELGER
53	27590051/0	2	PNEUMATICO TURF SAVER CARLISLE	SHOE TURF SAVER CARLISLE	PNEU TURF SAVER CARLISLE	REIFEN TURF SAVER CARLISLE
	27590053/0		DELI TIRE	DELI TIRE	DELI TIRE	DELI TIRE
54	12521410/0	2	RONDELLA	WASHER	RONDELLE	SCHEIBE
55	25670005/1	2	RONDELLA	WASHER	RONDELLE	SCHEIBE
56	12001010/0	2	ANELLO ELASTICO	SNAP RING	ANNEAU RESSORT	SPRENGRING
57	12520010/0	0-4	ROSETTA	WASHER	RONDELLE	SCHEIBE
58	22110230/0	2	COPRIMOZZO	HUB COVER	COUVRE MOYEU	NABEDECKEL
59	25950000/0	2	VALVOLA	VALVE	SOUPAPE	VENTIL
60	25160034/0	2	DISTANZIALE (Dana)	SPACER (Dana)	ENTRETOISE (Dana)	ENTFERNUNGSSTÜCK (Dana)

PER LA SOSTITUZIONE DELLE PARTI CONTRASSEGNALE CON «\*» RIVOLGERSI AL SERVIZIO ASSISTENZA DEL COSTRUTTORE DELLA TRASMISSIONE.  
 TO REPLACE THE PARTS MARKED «\*» SEEK ASSISTANCE FROM THE TRANSMISSION MANUFACTURER'S AFTER SALES SERVICE.  
 POUR LE REMPLACEMENT DES PIÈCES MARQUÉES AVEC «\*» S'ADRESSER AU SERVICE APRÈS VENTES DU CONSTRUCTEUR DE LA TRANSMISSION.  
 ZUM AUSTAUSCH DER MIT «\*» GEKENNZEICHNETEN TEILE, WENDEN SIE SICH AN DEN KUNDENDIENST DES HERSTELLERS DES ANTRIEBS.

www.emc-motoculture.com

F72

F72 hydro

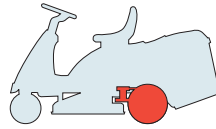

TRASMISSIONE  
TRANSMISSION  
TRANSMISSION  
GETRIEBE

2006

006Y.0

1 / 2

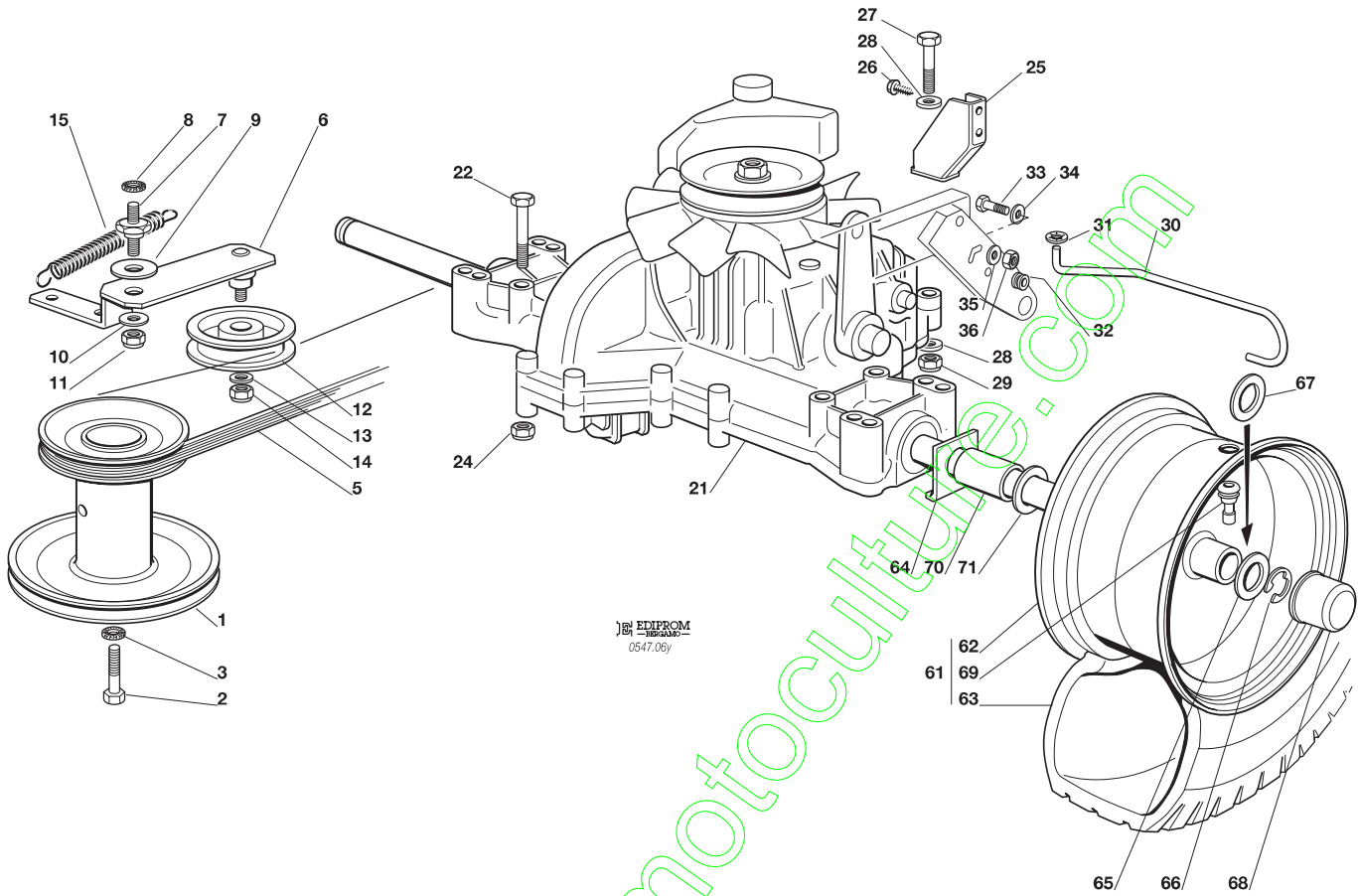

N.	CODE	Q.TY	DESCRIZIONE	DESCRIPTION	DESCRIPTION	BESCHREIBUNG
1	27604005/0	1	PULEGGIA	PULLEY	POULIE	RIEMENSCHLEIBE
2	12737310/0	1	VITE	SCREW	VIS	SCHRAUBE
3	12543000/0	1	ROSETTA	WASHER	RONDELLE	SCHEIBE
5	35061404/0	1	CINGHIA	BELT	COURROIE	RIEMEN
6	84317081/0	1	LEVA	LEVER	LEVIER	HEBEL
7	27510096/0	1	PERNO	PIN	PIVOT	BOLZEN
8	12540260/0	1	RONDELLA	WASHER	RONDELLE	SCHEIBE
9	22672151/0	1	RONDELLA	WASHER	RONDELLE	SCHEIBE
10	25670011/0	1	RONDELLA	WASHER	RONDELLE	SCHEIBE
11	12155010/0	1	DADO	NUT	ECROU	MUTTER
12	25601554/0	1	PULEGGIA	PULLEY	POULIE	RIEMENSCHLEIBE
13	12523060/0	1	RONDELLA	WASHER	RONDELLE	SCHEIBE
14	12155000/0	1	DADO	NUT	ECROU	MUTTER
15	22446402/0	1	MOLLA	SPRING	RESSORT	FEDER
21*	18400965/0	1	ASSE POSTERIORE <b>Tuff-Torq K46T</b>	REAR AXLE <b>Tuff-Torq K46T</b>	AXE ARRIERE <b>Tuff-Torq K46T</b>	HINTERACHSE <b>Tuff-Torq K46T</b>
22	12691800/0	4	VITE	SCREW	VIS	SCHRAUBE
24	12154210/0	4	DADO	NUT	ECROU	MUTTER
25	84783019/0	1	SUPPORTO	SUPPORT	SUPPORT	HALTER
26	12735121/0	1	VITE	SCREW	VIS	SCHRAUBE
27	12691200/0	1	VITE	SCREW	VIS	SCHRAUBE
28	12521350/0	1	RONDELLA	WASHER	RONDELLE	SCHEIBE
29	12155000/0	1	DADO	NUT	ECROU	MUTTER
30	27034069/0	1	LEVA	LEVER	LEVIER	HEBEL
31	12000930/0	1	FISSATORE A CORONA	CROWN FASTENER	FIXATEUR A COURONNE	KRONESCHLEIBE
32	18564512/0	1	PASSACAVO	FAIR LEAD	PASSE CABLE	KABELDURCHGANG
33	12793301/0	1	VITE	SCREW	VIS	SCHRAUBE
34	12523060/0	1	RONDELLA	WASHER	RONDELLE	SCHEIBE
35	12521350/0	1	RONDELLA	WASHER	RONDELLE	SCHEIBE
36	12155000/0	1	DADO	NUT	ECROU	MUTTER





N.	CODE	Q.TY	DESCRIZIONE	DESCRIPTION	DESCRIPTION	BESCHREIBUNG
61	•	2	RUOTA POSTERIORE	REAR WHEEL	ROUE ARRIERE	HINTERRAD
	84680050/1		TURF SAVER CARLISLE	TURF SAVER CARLISLE	TURF SAVER CARLISLE	TURF SAVER CARLISLE
	84680053/1		DELI TIRE	DELI TIRE	DELI TIRE	DELI TIRE
62	84044001/0	2	CERCHIO RUOTA	RIMM	BANDAGE ROUE	HINTRERRAD FELGER
63	•	2	PNEUMATICO	SHOE	PNEU	REIFEN
	27590051/0		TURF SAVER CARLISLE	TURF SAVER CARLISLE	TURF SAVER CARLISLE	TURF SAVER CARLISLE
	27590053/0		DELI TIRE	DELI TIRE	DELI TIRE	DELI TIRE
64	25670017/0	2	RONDELLA	WASHER	RONDELLE	SCHEIBE
65	25670005/1	2	RONDELLA	WASHER	RONDELLE	SCHEIBE
66	12001010/0	2	ANELLO ELASTICO	SNAP RING	ANNEAU RESSORT	SPRENGRING
67	25670006/0	0-4	ROSETTA	WASHER	RONDELLE	SCHEIBE
68	22110230/0	2	COPRIMOZZO	HUB COVER	COUVRE MOYEU	NABEDECKEL
69	25950000/0	2	VALVOLA	VALVE	SOUPAPE	VENTIL
70	25160031/0	2	DISTANZIALE	SPACER	ENTRETOISE	ENTFERNUNGSSTÜCK
71	25670005/1	2	ROSETTA	WASHER	RONDELLE	SCHEIBE

PER LA SOSTITUZIONE DELLE PARTI CONTRASSEGNAE CON «\*» RIVOLGERSI AL SERVIZIO ASSISTENZA DEL COSTRUTTORE DELLA TRASMISSIONE.  
TO REPLACE THE PARTS MARKED «\*» SEEK ASSISTANCE FROM THE TRANSMISSION MANUFACTURER'S AFTER SALES SERVICE.  
POUR LE REMPLACEMENT DES PIÈCES MARQUÉES AVEC «\*» S'ADRESSER AU SERVICE APRÈS VENTES DU CONSTRUCTEUR DE LA TRANSMISSION.  
ZUM AUSTAUSCH DER MIT «\*» GEKENNZEICHNETEN TEILE, WENDEN SIE SICH AN DEN KUNDENDIENST DES HERSTELLERS DES ANTRIEBS.

www.emc-motoculture.com

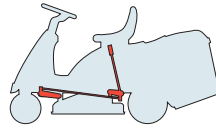
**F72****F72 hydro**
**SOLLEVAMENTO PIATTO DI TAGLIO**  
**CUTTING PLATE LIFTING**  
**SOULEVEMENT PLATEAU DE COUPE**  
**SCHNEIDWERKZEUG AUFHEBESATZ**

2006

**007.0**

1 / 1

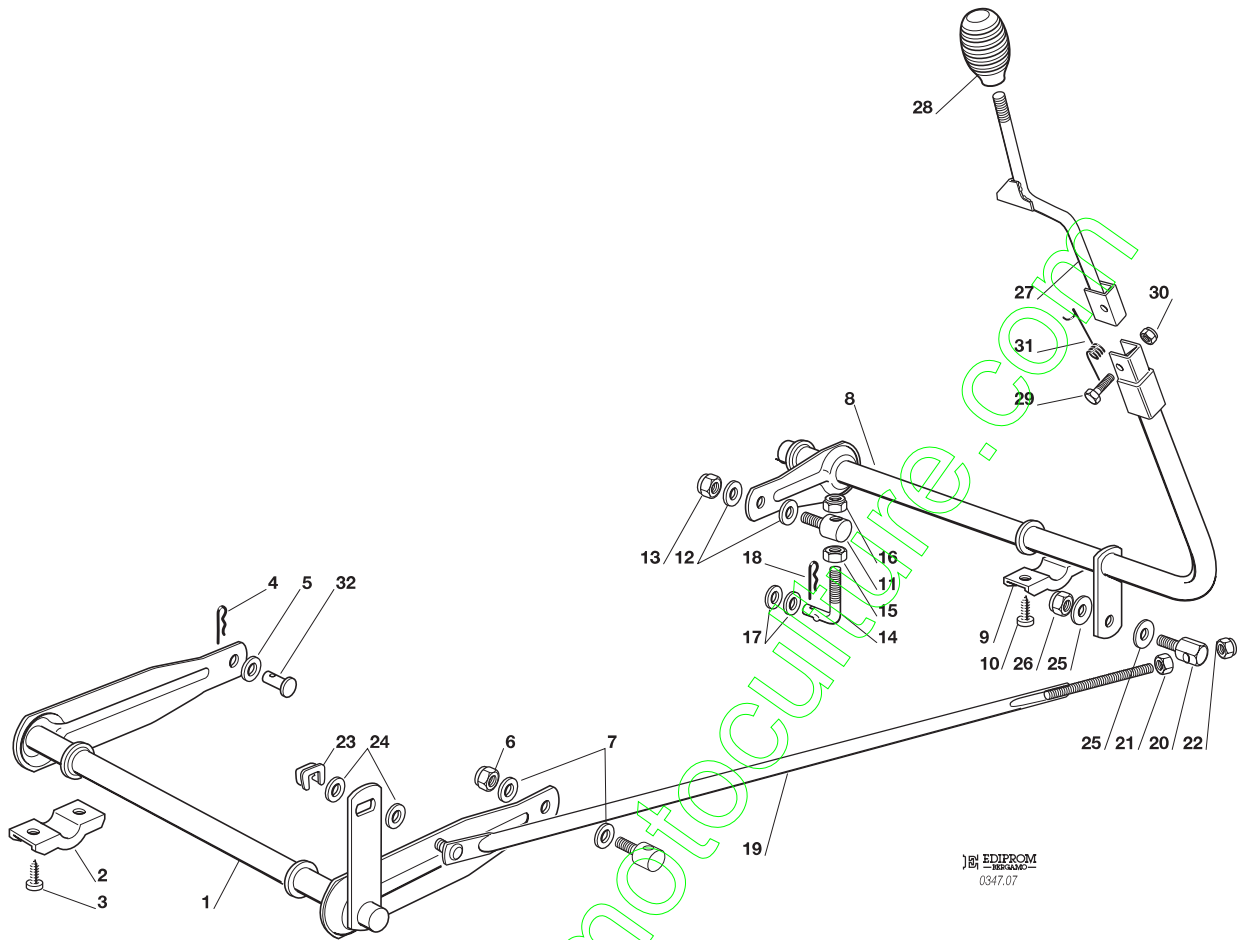

 EDIPROM  
 0347.07

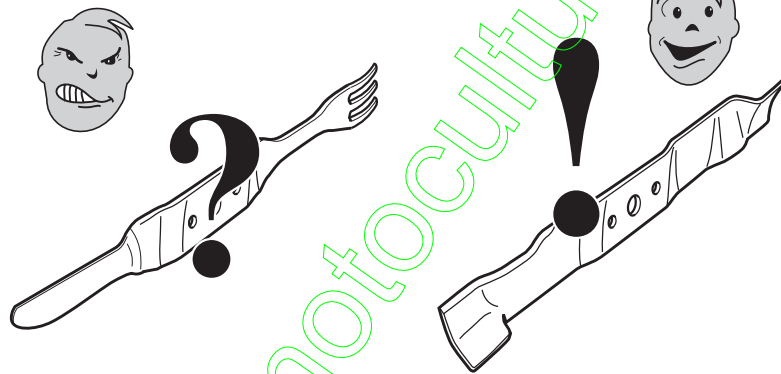
N.	CODE	Q.TY	DESCRIZIONE	DESCRIPTION	DESCRIPTION	BESCHREIBUNG
1	84001025/0	1	ASSE FULCRO PIATTO	AXLE	AXE	ACHSE
2	27546015/1	2	PIASTRINA	PLATE	PLAQUE	PLATTE
3	12731350/0	4	VITE	SCREW	VIS	SCHRAUBE
4	24487997/0	1	COPPIGLIA	COTTER PIN	GOUILLE	SPLIT
5	25670008/1	1	RONDELLA	WASHER	RONDELLE	SCHEIBE
6	12156602/0	1	DADO	NUT	ECROU	MUTTER
7	25670008/1	2	RONDELLA	WASHER	RONDELLE	SCHEIBE
8	84001005/2	1	ASSE FULCRO PIATTO	AXLE	AXE	ACHSE
9	27546015/1	2	PIASTRINA	PLATE	PLAQUE	PLATTE
10	12731350/0	4	VITE	SCREW	VIS	SCHRAUBE
11	25510007/1	1	PERNO	PIN	PIVOT	BOLZEN
12	25670008/1	2	RONDELLA	WASHER	RONDELLE	SCHEIBE
13	12156602/0	1	DADO	NUT	ECROU	MUTTER
14	25840003/2	1	TIRANTE	TIE ROD	TIRANT	SPANNSTANGE
15	12295200/0	1	DADO	NUT	ECROU	MUTTER
16	12156602/0	1	DADO	NUT	ECROU	MUTTER
17	22672150/0	2	RONDELLA	WASHER	RONDELLE	SCHEIBE
18	24487997/0	1	COPPIGLIA	COTTER PIN	GOUILLE	SPLIT
19	84002051/0	1	ASTA COLLEGAMENTO	ROD	TIGE	STAB
20	25510040/1	1	PERNO	PIN	PIVOT	BOLZEN
21	12293200/0	1	DADO	NUT	ECROU	MUTTER
22	12155000/0	1	DADO	NUT	ECROU	MUTTER
23	12436050/0	1	PIASTRINA	PLATE	PLAQUE	PLATTE
24	25670011/0	2	RONDELLA	WASHER	RONDELLE	SCHEIBE
25	25670011/0	2	RONDELLA	WASHER	RONDELLE	SCHEIBE
26	12155000/0	1	DADO	NUT	ECROU	MUTTER
27	84317065/1	1	LEVA SOLLEVAMENTO	LEVER	LEVIER	HEBEL
28	25394510/0	1	MANOPOLA	KNOB	POIGNEE	GRIF
29	12674700/0	1	VITE	SCREW	VIS	SCHRAUBE
30	12154510/0	1	DADO	NUT	ECROU	MUTTER
31	27430555/0	1	MOLLA	SPRING	RESSORT	FEDER
32	27510114/0	1	PERNO	PIN	PIVOT	BOLZEN



**USARE SOLO RICAMBI ORIGINALI!**  
**USE ONLY GENUINE SPARE PARTS!**  
**UTILISER DES PIÈCES DE RECHANGE D'ORIGINE!**  
**NUR ORIGINALERSATZTEILE VERWENDEN!**

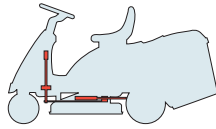

**F72****F72 hydro**
**PIATTO DI TAGLIO (1)**  
**CUTTING PLATE (1)**  
**PLATEAU DE COUPE (1)**  
**SCHNEIDWERKZEUG (1)**

2006

008.0

1 / 2

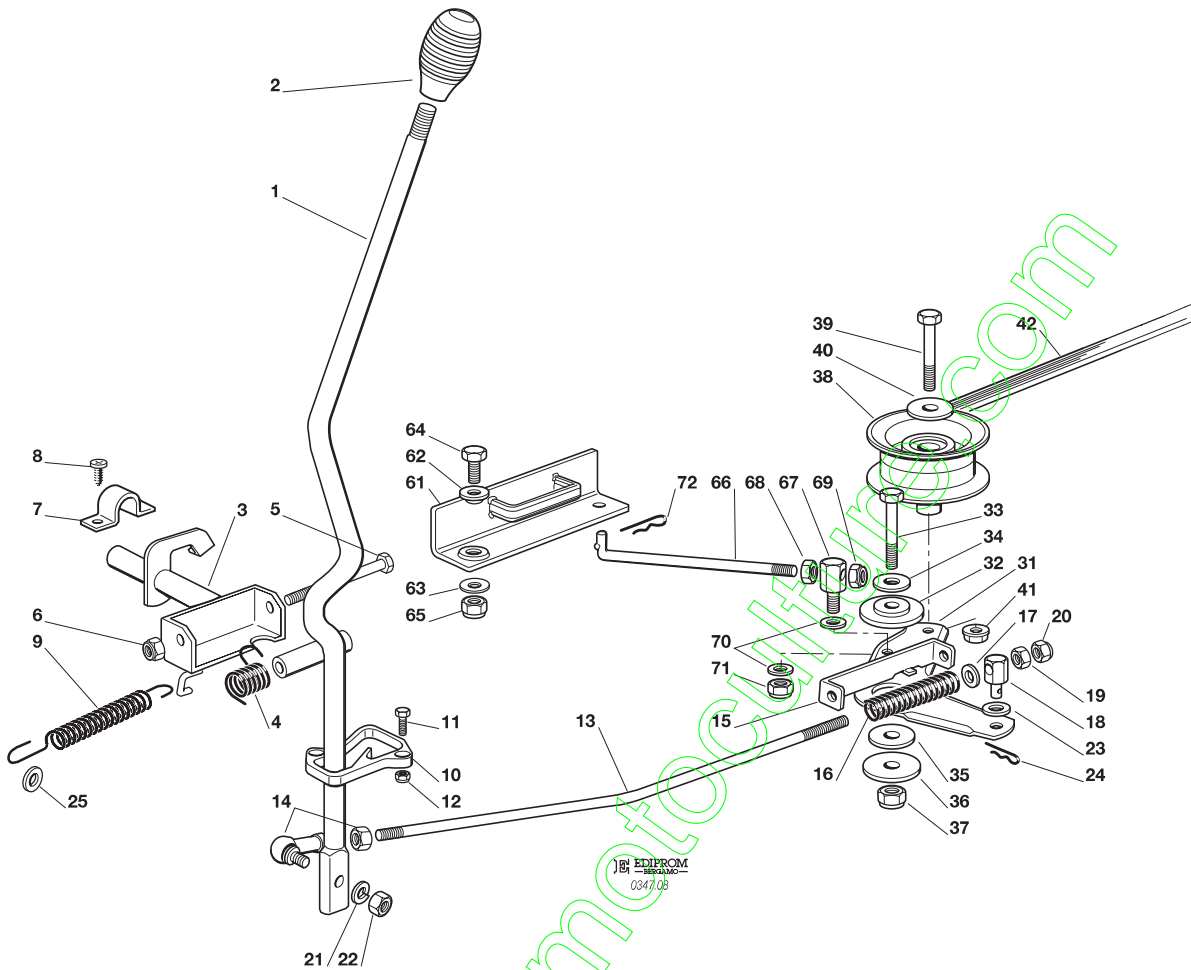

N.	CODE	Q.TY	DESCRIZIONE	DESCRIPTION	DESCRIPTION	BESCHREIBUNG
1	84317069/0	1	LEVA	LEVER	LEVIER	HEBEL
2	25394510/0	1	MANOPOLA	KNOB	POIGNEE	GRIFF
3	84001007/0	1	ASSE INNESTO LAMA	AXLE	AXE	ACHSE
4	25430226/0	1	MOLLA	SPRING	RESSORT	FEDER
5	12692050/0	1	VITE	SCREW	VIS	SCHRAUBE
6	12155000/0	1	DADO	NUT	ECROU	MUTTER
7	25547049/0	2	PIASTRINA	PLATE	PLAQUE	PLATTE
8	12731601/0	4	VITE	SCREW	VIS	SCHRAUBE
9	25430571/0	1	MOLLA	SPRING	RESSORT	FEDER
10	27487000/0	1	PATTINO	SHOE	BLOC DE GLISSEMENT	GLEITBLOCK
11	12791200/0	2	VITE	SCREW	VIS	SCHRAUBE
12	12154510/0	2	DADO	NUT	ECROU	MUTTER
13	27034078/0	1	ASTA	ROD	TIGE	STAB
14	22746601/0	1	SNODO	JOINT	JOINT	GELENK
15	27772143/0	1	STAFFA	CLAMP	ETRIER	BRIDE
16	25430576/0	1	MOLLA	SPRING	RESSORT	FEDER
17	12521350/0	1	RONDELLA	WASHER	RONDELLE	SCHEIBE
18	27510113/0	1	PERNO	PIN	PIVOT	BOLZEN
19	12293200/0	1	DADO	NUT	ECROU	MUTTER
20	12155000/0	1	DADO	NUT	ECROU	MUTTER
21	12583500/0	1	GROWER	GROWER	GROWER	GROWER
22	12293200/0	1	DADO	NUT	ECROU	MUTTER
23	25670008/1	1	RONDELLA	WASHER	RONDELLE	SCHEIBE
24	24487997/0	1	COPPIGLIA	COTTER PIN	GOUPILLE	SPLIT
25	25670006/0	1	RONDELLA	WASHER	RONDELLE	SCHEIBE
31	84317083/0	1	LEVA	LEVER	LEVIER	HEBEL
32	27047000/0	1	BUSSOLA	BUSH	DOUILLE	BÜCHSE
33	12691200/0	1	VITE	SCREW	VIS	SCHRAUBE
34	12523060/0	1	RONDELLA	WASHER	RONDELLE	SCHEIBE



N.	CODE	Q.TY	DESCRIZIONE	DESCRIPTION	DESCRIPTION	BESCHREIBUNG
35	22672152/0	1	RONDELLA	WASHER	RONDELLE	SCHEIBE
36	12523070/0	1	RONDELLA	WASHER	RONDELLE	SCHEIBE
37	12155000/0	1	DADO	NUT	ECROU	MUTTER
38	27604008/0	1	PULEGGIA	PULLEY	POULIE	RIEMENSCHLEIBE
39	12691600/0	1	VITE	SCREW	VIS	SCHRAUBE
40	12523060/0	1	ROSETTA	WASHER	RONDELLE	SCHEIBE
41	12293201/0	1	DADO	NUT	ECROU	MUTTER
42	35061423/0	1	CINGHIA	BELT	COURROIE	RIEMEN
61	84220501/0	1	FRENO LAMA	BRAKE	FREIN	BREMSE
62	22041980/0	1	BUSSOLA	BUSH	DOUILLE	BÜCHSE
63	22672152/0	1	RONDELLA	WASHER	RONDELLE	SCHEIBE
64	12793102/0	1	VITE	SCREW	VIS	SCHRAUBE
65	12155010/0	1	DADO	NUT	ECROU	MUTTER
66	27034077/0	1	ASTA	ROD	TIGE	STAB
67	25510040/1	1	PERNO	PIN	PIVOT	BOLZEN
68	12293200/0	1	DADO	NUT	ECROU	MUTTER
69	12155000/0	1	DADO	NUT	ECROU	MUTTER
70	25670011/0	2	RONDELLA	WASHER	RONDELLE	SCHEIBE
71	12155000/0	1	DADO	NUT	ECROU	MUTTER
72	24487997/0	1	COPPIGLIA	COTTER PIN	GOUPILLE	SPLIT

www.emc-motoculture.com

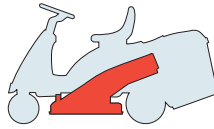
**F72****F72 hydro**
**PIATTO DI TAGLIO (2)**  
**CUTTING PLATE (2)**  
**PLATEAU DE COUPE (2)**  
**SCHNEIDWERKZEUG (2)**

2006

**009.0**

1 / 2

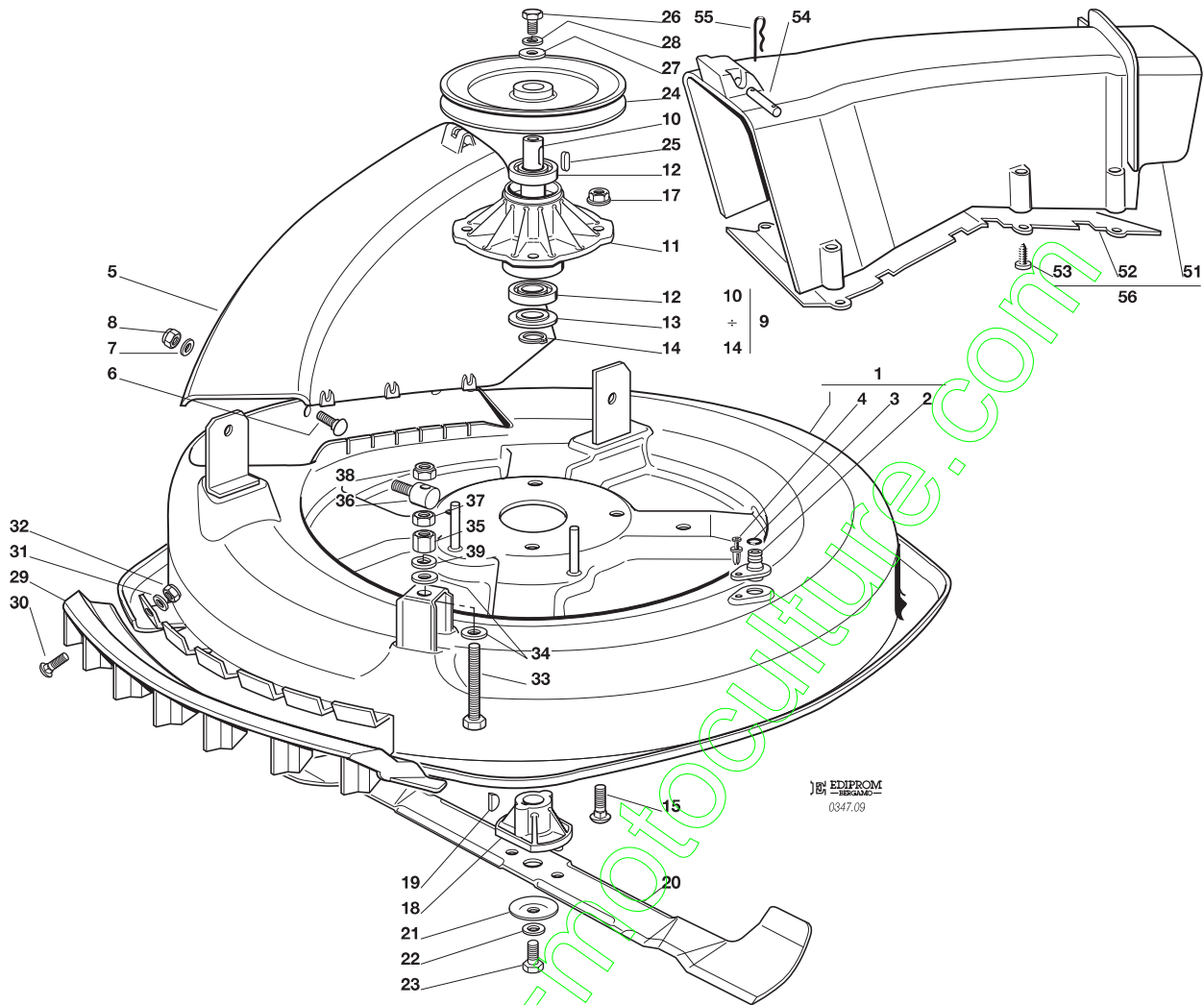

 EDIPROM  
 0347.09

N.	CODE	Q.TY	DESCRIZIONE	DESCRIPTION	DESCRIPTION	BESCHREIBUNG
1	84564097/0	1	PIATTO	PLATE	PLATEAU	SCHNEID
2	25033060/0	1	ATTACCO	WATER HOSE CONNECTION	RACCORD TUYAU D'EAU	WASSERANSCHLUSS
3	19035000/0	1	ANELLO OR	O RING	O RING	O RING
4	12500030/0	1	RIVETTO	RIVET	RIVET	NIET
5	27045000/0	1	BOCCA CONVOGLIATORE	CONVEYOR INLET	BOUCHE CONVOYEUR	BLECHSATZEINGANG
6	12815210/0	6	VITE	SCREW	VIS	SCHRAUBE
7	12523040/0	6	ROSETTA	WASHER	RONDELLE	SCHEIBE
8	12154510/0	6	DADO	NUT	ECROU	MUTTER
9	84207250/0	1	ASS. FLANGIA (10÷14)	FLANGE ASS.Y (10÷14)	ENS. BRIDE (10÷14)	NABE, KOMPLETT (10÷14)
10	27023000/0	1	ALBERO	SHAFT	ARBRE	WELLE
11	27208402/0	1	FLANGIA	FLANGE	BRIDE	FLANSCH
12	19216032/0	2	CUSCINETTO	BEARING	ROULEMENT	KUEGELLAGER
13	25160501/0	1	DISCO PARAPOLVERE	DUST COVER	PROTEGE-POUSSIERE	STAUBSCHUTTSCHIEBE
14	12609260/0	1	SEEGER	SEEGER	SEEGER	SEEGER
15	12818700/0	4	VITE	SCREW	VIS	SCHRAUBE
17	12154210/0	4	DADO	NUT	ECROU	MUTTER
18	25463200/0	1	MOZZO COLTELLO	BLADE HUB	MOYEU LAME	MESSERHALTER
19	12139100/0	1	LINGUETTA	KEY	CLAVETTE	KEIL
20	84109503/0	1	COLTELLO	BLADE	LAME	MESSER
21	22160400/0	1	DISCO ELASTICO	ELASTIC WASHER	RONDELLE ELASTIQUE	FEDERSCHIEBE
22	12523080/0	1	RONDELLA	WASHER	RONDELLE	SCHEIBE
23	12735694/0	1	VITE	SCREW	VIS	SCHRAUBE
24	27604009/0	1	PULEGGIA	PULLEY	POULIE	RIEMENSCHIEBE
25	12139480/0	1	CHIAVETTA	KEY	CLAVETTE	KEIL
26	12793102/0	1	VITE	SCREW	VIS	SCHRAUBE
27	25670007/0	1	RONDELLA	WASHER	RONDELLE	SCHEIBE
28	12583500/0	1	GROWER	GROWER	GROWER	GROWER
29	27488000/0	1	GRIGLIA ASPIRAZIONE	AIR INTAKE GRILL	GRILLE D'ASPIRATION	ANSAUGGITTER
30	12815200/0	4	VITE	SCREW	VIS	SCHRAUBE
31	12521340/0	4	ROSETTA	WASHER	RONDELLE	SCHEIBE

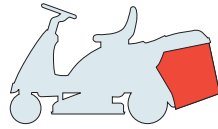

N.	CODE	Q.TY	DESCRIZIONE	DESCRIPTION	DESCRIPTION	BESCHREIBUNG
32	12154510/0	4	DADO	NUT	ECROU	MUTTER
33	12794970/0	1	VITE	SCREW	VIS	SCHRAUBE
34	12523080/0	2	ROSETTA	WASHER	RONDELLE	SCHEIBE
35	12154250/0	1	DADO	NUT	ECROU	MUTTER
36	25510007/1	1	PERNO	PIN	PIVOT	BOLZEN
37	12295200/0	1	DADO	NUT	ECROU	MUTTER
38	12156602/0	1	DADO	NUT	ECROU	MUTTER
39	12585100/0	1	GROWER	GROWER	GROWER	GROWER
—	84564099/0		PIATTO DI TAGLIO ASSEMBLATO (008, 31÷72 + 009, 1÷39)	CUTTING PLATE, ASSEMBLED (008, 31÷72 + 009, 1÷39)	PLATEAU DE COUPE,S COMPLETE (008, 31÷72 + 009, 1÷39)	CHNEIDWERKZEUG, KOMPLETT (008, 31÷72 + 009, 1÷39)
51	27107501/0	1	CONVOGLIATORE	CONVEYOR	CONVOYEUR	BLECHSATZ
52	27140051/1	1	DEFLETTORE	DEFLECTOR	DEFLECTEUR	ABWEISER
53	12735402/0	8	VITE	SCREW	VIS	SCHRAUBE
54	27510097/1	1	PERNO	PIN	PIVOT	BOLZEN
55	24487997/0	2	COPPIGLIA	COTTER PIN	GOUPILLE	SPLIT
56	84108051/0	1	ASS. CONVOGLIATORE (51, 52, 53)	CONVEYOR ASS.Y (51, 52, 53)	ENS. CONVOYEUR (51, 52, 53)	BLECHSATZ, KOMPLETT (51, 52, 53)

www.emc-motoculture.com

**F72****F72 hydro**
**SACCO  
GRASSCATCHER  
BAC  
AUFFANGSACK**

2006

**010.0**

1 / 1

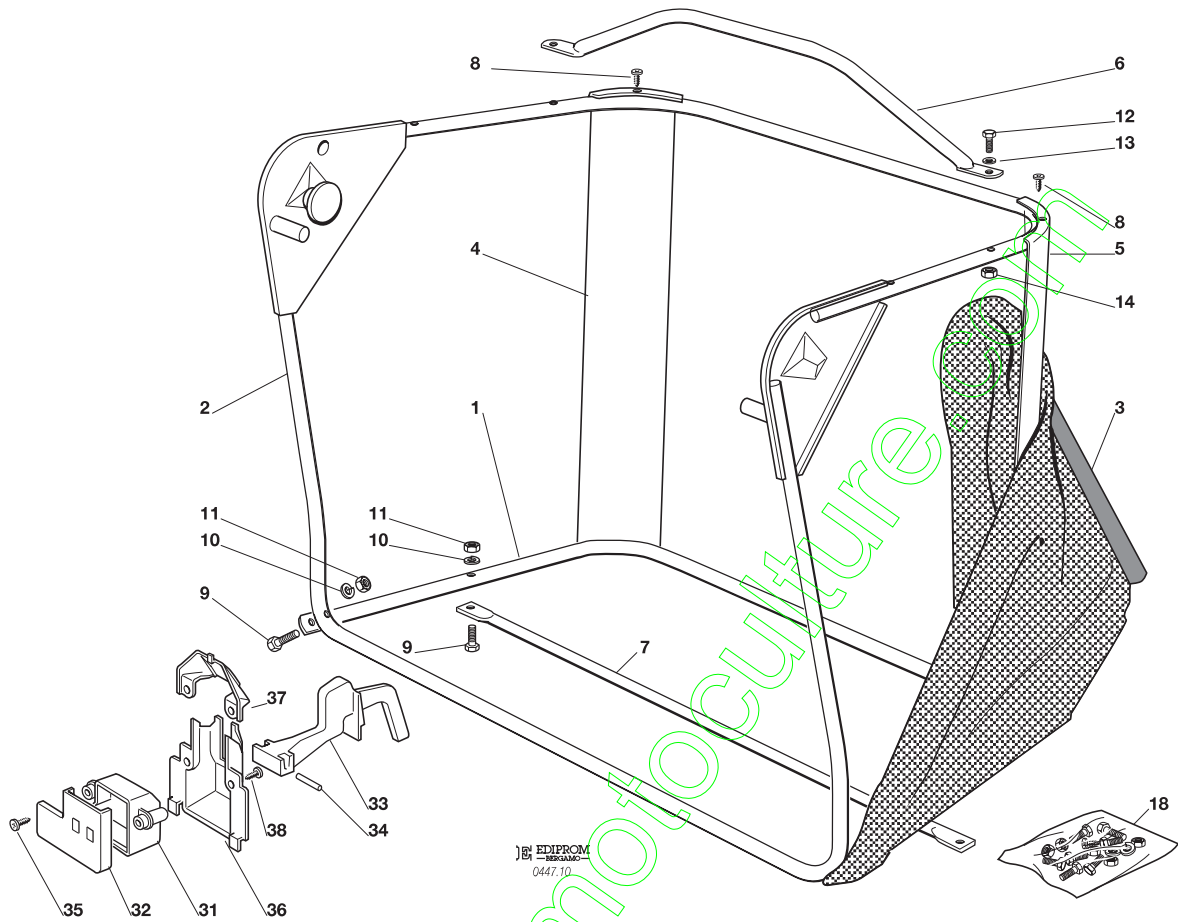

N.	CODE	Q.TY	DESCRIZIONE	DESCRIPTION	DESCRIPTION	BESCHREIBUNG
1	84801103/0	1	TELAIO INFERIORE	LOWER FRAME	CHASSIS INFÉRIEUR	UNTERERRAHMEN
2	84801105/1	1	TELAIO SUPERIORE	UPPER FRAME	CHASSIS SUPÉRIEUR	OBERERRAHMEN
3	84106050/1	1	CONFEZIONE SACCO	GRASSCATCHER	BAC	SACK
4	27010205/0	1	ANGOLARE DESTRO	RIGHT ANGULAR SUPPORT	SUPPORT ANGULAIRE DROITE	RECHTER HALTER
5	27010207/0	1	ANGOLARE SINISTRO	LEFT ANGULAR SUPPORT	SUPPORT ANGULAIRE GAUCHE	LINKER HALTER
6	84869051/0	1	TUBO	ROD	TIGE	STANGE
7	84650100/0	1	RINFORZO	STIFFENING	RENFORCEMENT	VERSTÄRKUNG
8	12729601/1	4	VITE	SCREW	VIS	SCHRAUBE
9	12792099/0	4	VITE	SCREW	VIS	SCHRAUBE
10	12582101/0	4	GROWER	GROWER	GROWER	GROWER
11	12292100/0	4	DADO	NUT	ECROU	MUTTER
12	12674701/0	2	VITE	SCREW	VIS	SCHRAUBE
13	12521331/0	2	RONDELLA	WASHER	RONDELLE	SCHEIBE
14	12154510/0	2	DADO	NUT	ECROU	MUTTER
18	84180180/0	1	DOTAZIONE VITERIA (8÷14)	SCREWS OUTFIT (8÷14)	ENSEMBLE DES VIS (8÷14)	SCHRAUBENAUSRÜSTUNG (8÷14)
31	25600041/0	1	PROTEZIONE MICRO	MICRO PROTECTION	PROTECTION MICRO	SCHUTZ
32	25600042/0	1	COPERCHIO PROTEZIONE	PROTECTION COVER	COUVERCLE PROTECTION	SCHUTZDEKEL
33	25318124/0	1	LEVA	LEVER	LEVIER	HEBEL
34	12400030/0	1	PERNO	PIN	PIVOT	BOLZEN
35	12728510/0	1	VITE	SCREW	VIS	SCHRAUBE
36	25600047/0	1	PROTEZIONE MICRO	MICRO PROTECTION	PROTECTION MICRO	SCHUTZ
37	25600048/0	1	CHIUSURA DEFLETTORE	DEFLECTOR COVER	COUVERCLE DEFLECTEUR	ABWEISERDEKEL
38	12728450/0	2	VITE	SCREW	VIS	SCHRAUBE

# F72

## F72 hydro

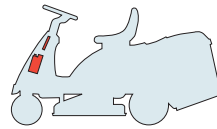

**PARTI ELETTRICHE**  
**ELECTRICAL PARTS**  
**PARTIES ELECTRIQUES**  
**ELETRISCHE TEILE**

2006

011.0

1 / 1

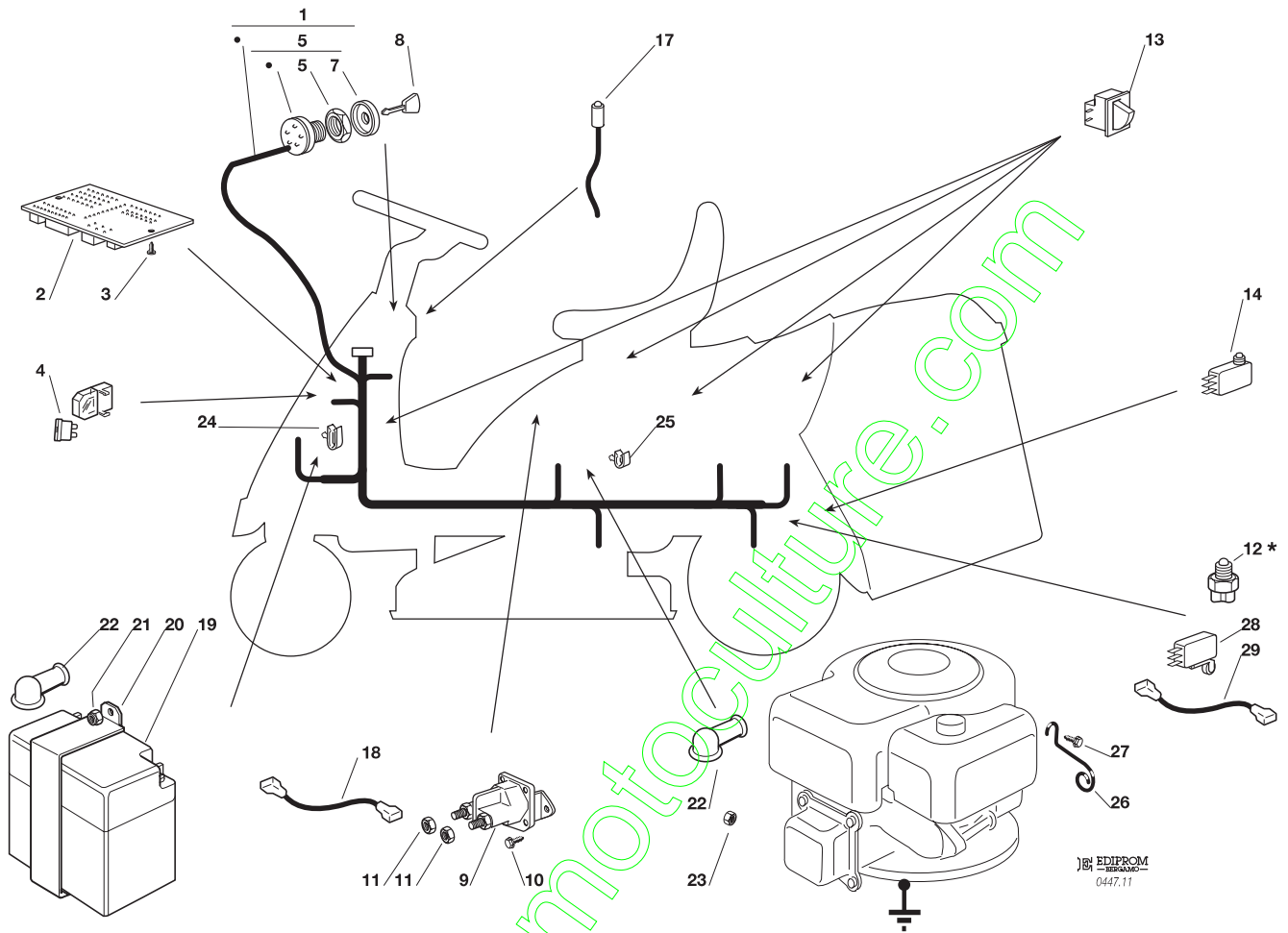

N.	CODE	Q.TY	DESCRIZIONE	DESCRIPTION	DESCRIPTION	BESCHREIBUNG
1	84040126/1	1	CABLAGGIO	CABLES	CABLAGES	KABELSATZ
2	25722415/1	1	SCHEDA ELETTRONICA	ELECTRONIC CARD	CARTE ELECTRONIQUE	ELEKTRONISCHE KARTE
3	12727810/0	2	VITE	SCREW	VIS	SCHRAUBE
4	33340040/0	1	FUSIBILE 10 A	FUSE 10 A	FUSIBLE 10 A	SICHERUNG 10 A
	33340036/0	1	FUSIBILE 25 A	FUSE 25 A	FUSIBLE 25 A	SICHERUNG 25 A
5	18450065/1	1	INTERRUTTORE AVVIAMENTO	STARTING SWITCH	INTERRUPTEUR DEMARRAGE	SCHALTER
6	18400861/0	1	GHIERA	SCREWED RING	EMBOUT	NUTMUTTER
7	18565351/0	1	PROTEZIONE GHIERA	SCREWED RING PROTECTION	PROTECTION EMBOUT	NUTMUTTER SCHUTZ
8	18210016/1	1	CHIAVE AVVIAMENTO	STARTING KEY	CLEF A DEMARRAGE	SCHLÜSSEL FÜR START
9	18736110/0	1	RELÉ AVVIAMENTO	STARTER RELAY	RELAIS D'ALLUMAGE	ANLASSRELAIS
10	12735110/0	2	VITE	SCREW	VIS	SCHRAUBE
11	12360352/0	2	DADO	NUT	ECROU	MUTTER
12*	-	1	INTERRUTT. CAMBIO (mecc.)	GEARBOX SWITCH (mech.)	INT. BOÎTE DE VITESSE (mec.)	ANTRIEB SCHALTER (mech.)
13	19410606/0	4	MICRO INTERRUTTORE	MICROSWITCH	MICROINTERRUPTEUR	MIKROSCHALTER
14	19410605/1	1	MICRO SACCO PIENO	FULL GRASSCATC. MICRO	MICRO BAC PLEIN	VOLLKORB VORRICHTUNG
17	25065014/1	1	CAVO LED SEGNALE	CABLE	CABLES	KABEL
18	27065050/0	1	CAVO BATTERIA SOLENOIDE	CABLE	CABLES	KABEL
19	18120002/1	1	BATTERIA	BATTERY	BATTERIE	BATTERIE
20	27772099/1	1	STAFFA	CLAMP	ETRIER	BRIDE
21	12155000/0	1	DADO	NUT	ECROU	MUTTER
22	18564861/1	2	CAPPUCCIO	PROTECTION	CAPUCHON	STECKER
23	12361005/0	1	DADO	NUT	ECROU	MUTTER
24	33320506/0	3	FERMACAVO	FAIRLEAD	FIXATION CABLE	KABELBEFESTIGUNG
25	33320504/0	1	FERMACAVO	FAIRLEAD	FIXATION CABLE	KABELBEFESTIGUNG
26	27430561/0	1	MOLLA	SPRING	RESSORT	FEDER
27	12735121/0	1	VITE	SCREW	VIS	SCHRAUBE
28	19410609/0	1	INTERRUTT. FOLLE (hydro)	MICROSWITCH (hydro)	MICROINTERRUPTEUR (hydro)	MIKROSCHALTER (hydro)
29	25065025/0	1	CAVO MICRO FOLLE (hydro)	CABLE (hydro)	CABLES (hydro)	KABEL (hydro)

PER LA SOSTITUZIONE DELLE PARTI CONTRASSEGNALE CON «\*» RIVOLGERSI AL SERVIZIO ASSISTENZA DEL COSTRUTTORE DELLA TRASMISSIONE.  
TO REPLACE THE PARTS MARKED «\*» SEEK ASSISTANCE FROM THE TRANSMISSION MANUFACTURER'S AFTER SALES SERVICE.  
POUR LE REMPLACEMENT DES PIÈCES MARQUÉES AVEC «\*» S'ADRESSER AU SERVICE APRÈS VENTES DU CONSTRUCTEUR DE LA TRANSMISSION.  
ZUM AUSTAUSCH DER MIT «\*» GEKENNZEICHNETEN TEILE, WENDEN SIE SICH AN DEN KUNDENDIENST DES HERSTELLERS DES ANTRIEBS.

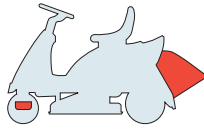
**F72****F72 hydro**

**ACCESSORI A RICHIESTA**  
**OPTIONALS ON REQUEST**  
**ACCESSOIRES SUR DEMANDE**  
**ZUBEHOERE NACH ANFRAGE**

2006

**012.0**

1 / 2

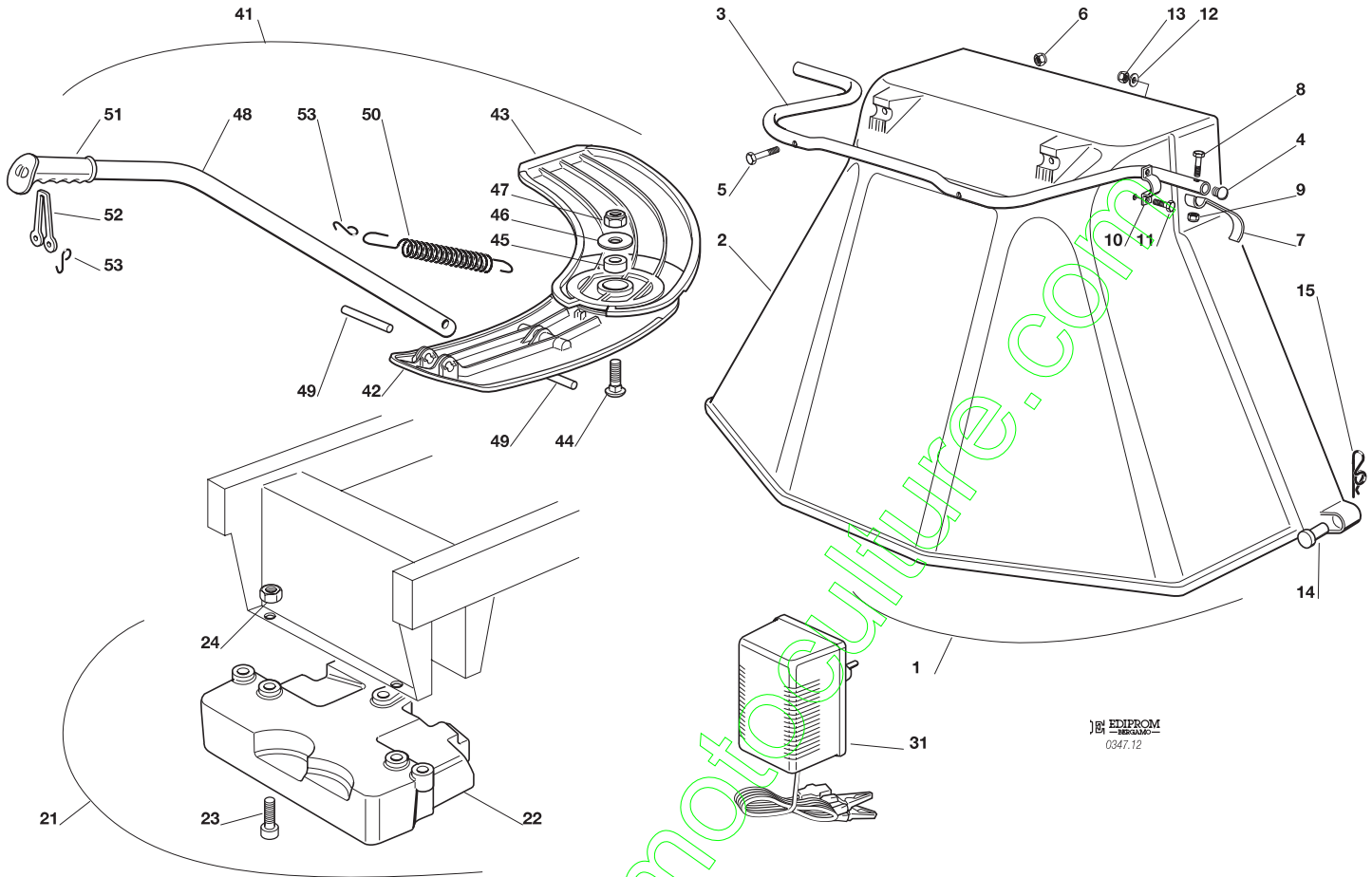

EDIPROM  
 0347.12

N.	CODE	Q.TY	DESCRIZIONE	DESCRIPTION	DESCRIPTION	BESCHREIBUNG
1	99900090/0	1	ASS. KIT PROTEZIONE USCITA	EJECTION-GUARD ASS.Y	KIT PROTECTION SORTIE	VORRICHTUNG FÜR AUSWURFSCHUTZ
2	84598062/0	1	PROTEZIONE USCITA	EJECTION GUARD	PROTECTION SORTIE	AUSWURFSCHUTZ
3	27869053/0	1	TUBO DI AGGANCIO	SUPPORT	SOPPORT	HALTER
4	18566113/0	2	PUNTALE	CAP	BOUCHON	PFROPFEN
5	12674701/0	2	VITE	SCREW	VIS	SCHRAUBE
6	12154510/0	2	DADO	NUT	ECROU	MUTTER
7	25547053/0	1	PIASTRINA	PLATE	PLAQUETTE	PLÄTTCHEN
8	12791500/0	1	VITE	SCREW	VIS	SCHRAUBE
9	12154510/0	1	DADO	NUT	ECROU	MUTTER
10	25547049/0	2	PIASTRINA	PLATE	PLAQUETTE	PLÄTTCHEN
11	12788910/0	4	VITE	SCREW	VIS	SCHRAUBE
12	12523020/0	4	ROSETTA	WASHER	RONDELLE	SCHEIBE
13	12154320/0	4	DADO	NUT	ECROU	MUTTER
14	25510022/0	2	PERNO	PIN	PIVOT	BOLZEN
15	24487998/0	2	COPPIGLIA	COTTER PIN	GOUILLE	SPLIT
21	99900030/6	1	ASS. KIT PESO ANT.	FRONT WEIGHT KIT	KIT POIDS ANTERIEUR	VORDERGEWICHT VORRICHTUNG
22	25519997/1	1	PESO	WEIGHT	POIDS	GEWICHT
23	12760520/0	3	VITE	SCREW	VIS	SCHRAUBE
24	12155000/0	3	DADO	NUT	ECROU	MUTTER
31	82180050/0	1	CARICA BATTERIE	BATTERY CHARGER	CHARGEUR DE BATTERIES	BATTERIELADEGERÄT
	82180052/0	1	CARICA BATTERIE (U.K.)	BATTERY CHARGER (U.K.)	CHARGEUR DE BATTERIES (U.K.)	BATTERIELADEGERÄT (U.K.)
41	99900036/0	1	KIT MULCHING	MULCHING KIT	KIT MULCHING	MULCHINGVORRICHTUNG
42	27140055/0	1	DEFLETTORE POST.	DEFLECTOR, REAR	DEFLECTEUR, ARRIERE	ABWEISER, HINTER
43	27140054/0	1	DEFLETTORE ANTER.	DEFLECTOR, FRONT	DEFLECTEUR, AVANT	ABWEISER, VORDER



N.	CODE	Q.TY	DESCRIZIONE	DESCRIPTION	DESCRIPTION	BESCHREIBUNG
44	12818700/0	1	VITE	SCREW	VIS	SCHRAUBE
45	27047013/0	1	BUSSOLA	BUSHING	DOUILLE	LAGER
46	22672152/0	1	RONDELLA	WASHER	RONDELLE	SCHEIBE
47	12155000/0	1	DADO	NUT	ECROU	MUTTER
48	27394003/2	1	MANICO	HANDLE	GUIDON	STIEL
49	27510116/0	2	PERNO	PIN	PIVOT	BOLZEN
50	25430229/1	1	MOLLA	SPRING	RESSORT	FEDER
51	25280000/1	1	IMPUGNATURA	HANDGRIP	BRANCHE	GRIFF
52	25840011/1	1	TIRANTE IN GOMMA	ELASTIC TIE-ROD	TIRANT ELASTIQUE	ELASTISCHE ZUGSTÄBE
53	25253004/0	3	GANCIO	HOOK	CROCHET	HAKEN

www.emc-motoculture.com



**F72**

**F72 hydro**

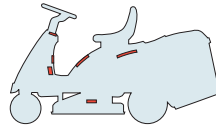

**ETICHETTE  
LABELS  
ETIQUETTES  
KLEBZETTEL**

2006

**013.0**

1 / 1

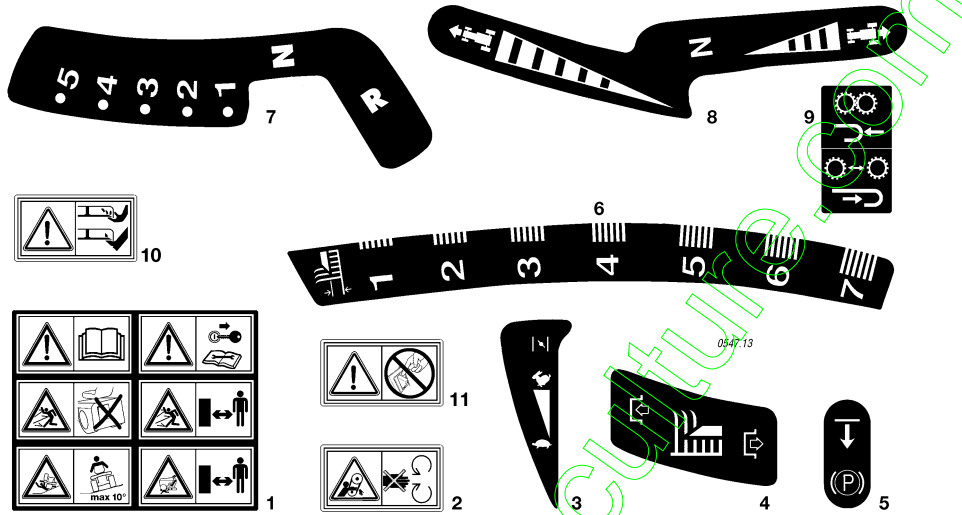

N.	CODE	Q.TY	DESCRIZIONE	DESCRIPTION	DESCRIPTION	BESCHREIBUNG
1	14357428/0	1	ETICHETTA	LABEL	ETIQUETTE	KLEBZETTEL
2	14357519/1	1	ETICHETTA	LABEL	ETIQUETTE	KLEBZETTEL
3	14357425/0	1	ETICHETTA	LABEL	ETIQUETTE	KLEBZETTEL
4	14357431/0	1	ETICHETTA	LABEL	ETIQUETTE	KLEBZETTEL
5	14357526/0	1	ETICHETTA	LABEL	ETIQUETTE	KLEBZETTEL
6	14357427/0	1	ETICHETTA	LABEL	ETIQUETTE	KLEBZETTEL
7	14357426/0	1	ETICHETTA (mecc.)	LABEL (mech.)	ETIQUETTE (mec.)	KLEBZETTEL (mech.)
8	14357702/0	1	ETICHETTA (hydro)	LABEL (hydro)	ETIQUETTE (hydro)	KLEBZETTEL (hydro)
9	14358513/0	1	ETICHETTA (hydro)	LABEL (hydro)	ETIQUETTE (hydro)	KLEBZETTEL (hydro)
10	14356699/0	2	ETICHETTA	LABEL	ETIQUETTE	KLEBZETTEL
11	14360118/0	1	ETICHETTA	LABEL	ETIQUETTE	KLEBZETTEL

ELENCO NUMERICO  
NUMERICAL LIST  
LISTE NUMERIQUE  
NUMERISCHE AUFSTELLUNG

[www.emc-motoculture.com](http://www.emc-motoculture.com)

**F72**

**F72 hydro**

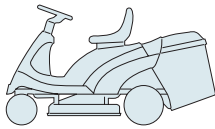

**ELENCO NUMERICO  
NUMERICAL LIST  
LISTE NUMERIQUE  
NUMERISCHE AUFSTELLUNG**

2006

**999.0**

1 / 3

CODE	TABLE	N.	Q.TY	CODE	TABLE	N.	Q.TY	CODE	TABLE	N.	Q.TY
12000930/0	006Y.0	31	1	12292102/0	004Y.0	84	2	12523070/0	002.0	21	2
12000955/0	001.0	54	2	12293200/0	004M.0	14	1	12523070/0	008.0	36	1
12001000/0	003.0	9	2	12293200/0	004M.0	25	2	12523080/0	009.0	22	1
12001000/0	003.0	25	2	12293200/0	004M.0	51	1	12523080/0	009.0	34	2
12001000/0	003.0	56	2	12293200/0	004Y.0	25	2	12523100/0	003.0	28	2
12001010/0	006M.0	56	2	12293200/0	004Y.0	73	1	12540020/0	004Y.0	119	2
12001010/0	006Y.0	66	2	12293200/0	004Y.0	87	2	12540040/0	004M.0	53	1
12139100/0	009.0	19	1	12293200/0	006M.0	17	2	12540260/0	005.0	8	1
12139430/0	006M.0	22	1	12293200/0	007.0	21	1	12540260/0	006M.0	8	1
12139480/0	009.0	25	1	12293200/0	008.0	19	1	12540260/0	006Y.0	8	1
12154210/0	005.0	6	3	12293200/0	008.0	22	1	12543000/0	006M.0	3	1
12154210/0	005.0	9	1	12293200/0	008.0	68	1	12543000/0	006Y.0	3	1
12154210/0	005.0	16	2	12293201/0	001.0	10	4	12581100/0	004Y.0	117	2
12154210/0	006M.0	27	4	12293201/0	001.0	13	4	12581200/0	002.0	43	2
12154210/0	006Y.0	24	4	12293201/0	001.0	17	4	12582101/0	010.0	10	4
12154210/0	009.0	17	4	12293201/0	001.0	36	4	12583500/0	002.0	55	4
12154250/0	009.0	35	1	12293201/0	002.0	91	2	12583500/0	003.0	12	1
12154320/0	012.0	13	4	12293201/0	004M.0	33	2	12583500/0	004M.0	50	1
12154330/0	002.0	67	2	12293201/0	004Y.0	61	2	12583500/0	005.0	13	2
12154330/0	002.0	70	1	12293201/0	006M.0	33	1	12583500/0	008.0	21	1
12154510/0	002.0	17	2	12293201/0	008.0	41	1	12583500/0	009.0	28	1
12154510/0	004M.0	21	1	12295200/0	007.0	15	1	12585100/0	009.0	39	1
12154510/0	004Y.0	114	1	12295200/0	009.0	37	1	12587100/0	003.0	29	1
12154510/0	007.0	30	1	12295300/0	003.0	30	1	12608600/0	004M.0	36	1
12154510/0	008.0	12	2	12360352/0	011.0	11	2	12608900/0	004Y.0	105	2
12154510/0	009.0	8	6	12361005/0	011.0	23	1	12608950/0	006M.0	23	1
12154510/0	009.0	32	4	12379511/0	001.0	26	1	12609260/0	009.0	14	1
12154510/0	010.0	14	2	12379511/0	003.0	22	2	12620299/0	002.0	62	1
12154510/0	012.0	6	2	12379511/0	004Y.0	53	1	12622650/0	003.0	3	1
12154510/0	012.0	9	1	12400030/0	010.0	34	1	12674700/0	007.0	29	1
12155000/0	001.0	24	1	12436030/0	003.0	6	1	12674701/0	010.0	12	2
12155000/0	002.0	22	2	12436050/0	007.0	23	1	12674701/0	012.0	5	2
12155000/0	004M.0	5	2	12437502/0	002.0	75	2	12691100/0	005.0	5	3
12155000/0	004M.0	26	1	12437503/0	002.0	13	2	12691115/0	005.0	7	1
12155000/0	004M.0	41	1	12437504/0	005.0	20	3	12691200/0	002.0	20	2
12155000/0	004M.0	48	1	12500030/0	009.0	4	1	12691200/0	006Y.0	27	1
12155000/0	004Y.0	5	2	12500090/0	001.0	25	1	12691200/0	008.0	33	1
12155000/0	004Y.0	21	1	12520010/0	006M.0	57	0-4	12691600/0	008.0	39	1
12155000/0	004Y.0	58	1	12520031/0	003.0	10	0-2	12691800/0	006M.0	25	4
12155000/0	004Y.0	92	1	12521320/0	002.0	74	2	12691800/0	006Y.0	22	4
12155000/0	006M.0	14	1	12521330/0	004Y.0	54	1	12691900/0	006M.0	25	4
12155000/0	006M.0	18	1	12521330/0	004Y.0	83	2	12692050/0	004M.0	40	1
12155000/0	006M.0	20	1	12521330/0	004Y.0	113	2	12692050/0	004Y.0	57	1
12155000/0	006M.0	35	1	12521331/0	001.0	19	2	12692050/0	008.0	5	1
12155000/0	006Y.0	14	1	12521331/0	002.0	28	4	12692695/0	003.0	27	1
12155000/0	006Y.0	29	1	12521331/0	010.0	13	2	12726388/0	002.0	45	1
12155000/0	006Y.0	36	1	12521331/0	009.0	31	4	12727810/0	011.0	3	2
12155000/0	007.0	22	1	12521340/0	003.0	31	1	12728450/0	010.0	38	2
12155000/0	007.0	26	1	12521350/0	004M.0	17	2	12728460/0	002.0	73	2
12155000/0	008.0	6	1	12521350/0	006M.0	34	1	12728510/0	010.0	35	1
12155000/0	008.0	20	1	12521350/0	006Y.0	28	1	12729601/1	002.0	27	4
12155000/0	008.0	37	1	12521350/0	006Y.0	35	1	12729601/1	005.0	19	3
12155000/0	008.0	69	1	12521350/0	008.0	17	1	12729601/1	010.0	8	4
12155000/0	008.0	71	1	12521360/0	004Y.0	17	2	12731350/0	004M.0	7	4
12155000/0	011.0	21	1	12521370/0	003.0	5	1	12731350/0	004Y.0	7	4
12155000/0	012.0	24	3	12521370/0	004M.0	35	2	12731350/0	007.0	3	4
12155000/0	012.0	47	1	12521410/0	006M.0	54	2	12731350/0	007.0	10	4
12155010/0	004Y.0	40	1	12523020/0	002.0	66	2	12731601/0	004M.0	10	4
12155010/0	004Y.0	75	1	12523020/0	012.0	12	4	12731601/0	004Y.0	10	4
12155010/0	004Y.0	89	1	12523040/0	001.0	43	1	12731601/0	008.0	8	4
12155010/0	006M.0	11	1	12523040/0	002.0	11	4	12734995/0	001.0	18	2
12155010/0	006Y.0	11	1	12523040/0	002.0	16	2	12735106/0	001.0	48	2
12155010/0	008.0	65	1	12523040/0	002.0	85	2	12735110/0	001.0	40	1
12155020/0	004Y.0	43	1	12523040/0	009.0	7	6	12735110/0	001.0	46	2
12155020/0	004Y.0	52	1	12523050/0	004M.0	20	1	12735110/0	001.0	56	1
12156602/0	003.0	19	4	12523050/0	004Y.0	20	1	12735110/0	004Y.0	48	2
12156602/0	004Y.0	27	1	12523060/0	001.0	23	1	12735110/0	011.0	10	2
12156602/0	007.0	6	1	12523060/0	002.0	56	4	12735120/0	001.0	42	1
12156602/0	007.0	13	1	12523060/0	004Y.0	39	1	12735121/0	004Y.0	102	2
12156602/0	007.0	16	1	12523060/0	006M.0	13	1	12735121/0	006Y.0	26	1
12156602/0	009.0	38	1	12523060/0	006M.0	32	1	12735121/0	011.0	27	1
12290791/0	004Y.0	118	2	12523060/0	006Y.0	13	1	12735150/0	006M.0	29	2
12290800/0	002.0	46	1	12523060/0	006Y.0	34	1	12735402/0	002.0	9	10
12292100/0	010.0	11	4	12523060/0	008.0	34	1	12735402/0	002.0	24	4
12292102/0	001.0	7	8	12523060/0	008.0	40	1	12735402/0	002.0	26	2





CODE	TABLE	N.	Q.TY	CODE	TABLE	N.	Q.TY	CODE	TABLE	N.	Q.TY
27109505/0	002.0	7	1	27772101/0	004Y.0	36	1	84598081/0	005.0	17	1
27109507/0	002.0	7	1	27772103/0	004Y.0	37	1	84650100/0	010.0	7	1
27109515/1	002.0	7	1	27772105/0	004Y.0	81	1	84680050/1	006M.0	51	2
27110302/2	002.0	4	1	27772143/0	008.0	15	1	84680050/1	006Y.0	61	2
27110303/1	002.0	5	1	27787025/0	001.0	15	2	84680052/1	003.0	51	2
27110304/0	002.0	29	1	27787062/0	002.0	81	1	84680053/1	006M.0	51	2
27110305/0	002.0	30	1	27787063/0	002.0	89	1	84680053/1	006Y.0	61	2
27110306/2	002.0	6	1	27840050/0	003.0	16	2	84680055/1	003.0	51	2
27110317/1	002.0	4	1	27864052/0	002.0	57	1	84735551/0	003.0	7	1
27110319/1	002.0	4	1	27869053/0	012.0	3	1	84773551/0	004M.0	31	1
27110321/0	002.0	5	1	27943050/0	001.0	34	2	84773553/0	004M.0	38	1
27110323/0	002.0	5	1	33320504/0	011.0	25	1	84773561/0	004Y.0	34	1
27110353/1	002.0	4	1	33320506/0	011.0	24	3	84773563/0	004Y.0	49	1
27110354/1	002.0	5	1	33340036/0	011.0	4	1	84773565/0	004Y.0	46	1
27140051/1	009.0	52	1	33340040/0	011.0	4	1	84773568/0	004Y.0	32	1
27140054/0	012.0	43	1	35061400/0	006M.0	5	1	84783019/0	006Y.0	25	1
27140055/0	012.0	42	1	35061404/0	006Y.0	5	1	84783027/0	001.0	11	1
27158000/0	004Y.0	44	2	35061423/0	008.0	42	1	84801103/1	010.0	1	1
27208402/0	009.0	11	1	82180050/0	012.0	31	1	84801105/1	010.0	2	1
27275000/0	004Y.0	26	1	82180052/0	012.0	31	1	84801107/1	001.0	14	1
27294001/0	001.0	41	1	82394508/0	004M.0	42	1	84801127/0	001.0	8	1
27294002/0	001.0	45	1	82394508/0	004Y.0	59	1	84801135/0	001.0	1	1
27294003/0	001.0	45	1	82601503/0	006M.0	21	1	84869051/0	010.0	6	1
27315077/0	004M.0	45	1	82750006/1	005.0	14	1	99900030/6	012.0	21	1
27315109/0	004M.0	45	1	84000250/1	002.0	41	1	99900036/0	012.0	41	1
27394003/2	012.0	48	1	84000501/0	003.0	8	1	99900090/0	012.0	1	1
27395050/1	004M.0	12	1	84001005/2	007.0	8	1				
27395050/1	004Y.0	12	1	84001007/0	008.0	3	1				
27430551/1	002.0	19	2	84001011/2	004M.0	8	1				
27430552/0	004M.0	11	1	84001011/2	004Y.0	8	1				
27430552/0	004Y.0	11	1	84001015/1	004M.0	3	1				
27430554/0	001.0	39	1	84001015/1	004Y.0	3	1				
27430555/0	007.0	31	1	84001023/0	004Y.0	104	1				
27430560/0	004Y.0	50	1	84001025/0	007.0	1	1				
27430561/0	011.0	26	1	84002051/0	007.0	19	1				
27430577/0	001.0	52	2	84034057/0	003.0	20	1				
27487000/0	008.0	10	1	84040126/1	011.0	1	1				
27488000/0	009.0	29	1	84040300/0	001.0	20	1				
27510096/0	006M.0	7	1	84044000/0	003.0	52	2				
27510096/0	006Y.0	7	1	84044001/0	006M.0	52	2				
27510097/1	009.0	54	1	84044001/0	006Y.0	62	2				
27510110/0	004Y.0	109	1	84106050/0	010.0	3	1				
27510111/0	004Y.0	107	1	84108051/0	009.0	56	1				
27510113/0	008.0	18	1	84109503/0	009.0	20	1				
27510114/0	007.0	32	1	84110100/3	002.0	8	1				
27510115/0	004M.0	15	1	84110102/2	002.0	8	1				
27510116/0	012.0	49	2	84110104/2	002.0	8	1				
27510118/0	002.0	90	1	84110107/3	002.0	8	1				
27520050/0	003.0	1	1	84110109/2	002.0	8	1				
27546001/0	002.0	23	2	84110111/2	002.0	8	1				
27546003/0	002.0	25	2	84110117/2	002.0	3	1				
27546015/1	004M.0	6	2	84110118/1	002.0	3	1				
27546015/1	004Y.0	6	2	84110120/1	002.0	3	1				
27546015/1	007.0	2	2	84110128/2	002.0	8	1				
27546015/1	007.0	9	2	84110129/2	002.0	8	1				
27546019/0	004Y.0	115	1	84110130/1	002.0	3	1				
27546047/0	004Y.0	101	2	84180180/0	010.0	18	1				
27570050/0	003.0	4	1	84207101/1	004Y.0	80	1				
27590050/0	003.0	54	2	84207250/0	009.0	9	1				
27590051/0	006M.0	53	2	84220501/0	008.0	61	1				
27590051/0	006Y.0	63	2	84230401/0	003.0	23	1				
27590052/0	003.0	54	2	84230403/0	003.0	24	1				
27590053/0	006M.0	53	2	84250053/0	001.0	55	1				
27590053/0	006Y.0	63	2	84317051/2	004M.0	37	1				
27600061/2	002.0	86	1	84317051/2	004Y.0	55	1				
27600091/1	002.0	2	1	84317055/1	006M.0	6	1				
27600092/0	002.0	2	1	84317065/1	007.0	27	1				
27600094/0	002.0	2	1	84317069/0	008.0	1	1				
27600111/1	002.0	2	1	84317081/0	006Y.0	6	1				
27600137/0	005.0	18	1	84317083/0	008.0	31	1				
27604003/1	006M.0	1	1	84503001/0	004M.0	1	1				
27604005/0	006Y.0	1	1	84503001/0	004Y.0	1	1				
27604008/0	008.0	38	1	84545057/3	001.0	3	1				
27604009/0	009.0	24	1	84564097/0	009.0	1	1				
27670053/0	004Y.0	45	2	84564099/0	009.0	—	1				
27733003/1	002.0	83	1	84598062/0	012.0	2	1				
27734055/0	004Y.0	41	1	84598064/1	002.0	1	1				
27772067/0	006M.0	28	2	84598065/0	002.0	1	1				
27772095/0	001.0	47	1	84598067/0	002.0	1	1				
27772099/1	011.0	20	1	84598076/1	002.0	1	1				