

Repère	Référence	Désignation	Quantité
1540	1540	CIRCLIPS	1,000
2235	2235	RDLE PL.A 6,4	1,000
5232	5232	ECROU AUTOFREIN HM6	1,000
7036	7036	ECROU PAPILLON	1,000
20520	20520	VIS JAPY M8 X 45	1,000
21436	21436	ECROU NUL 530	1,000
22029	22029	RDLE PL.B 6,5	1,000
41211	41211	RENFORT ARCEAU	1,000
41422	41422	RESSORT DEVERROUILL	1,000
41500	41500	CACHE GAUCHE	1,000
41501	41501	CACHE DROIT	1,000
41502	41502	DOUILLE LOQUET	1,000
41507	41507	BUTEE ENTRAINEUR	1,000
41510	41510	REVETEMENT CPO	1,000
41512	41512	PIGNON AVANCE	1,000
41513	41513	SECTEUR CRANTE	1,000
41514	41514	BUTEE GAINÉ DOUBLE	1,000
41515	41515	ARCEAU AVANCE COMPL	1,000
41516	41516	ARCEAU CPO COMPLET	1,000
41517	41517	DOUILLE CROCHET	1,000
41520	41520	RESSORT CROCHET	1,000
41533	41533	RESSORT ENTRAINEUR	1,000
41540	41540	ARTICULATION CPO G	1,000
41541	41541	ARTICULATION CPO DR	1,000
41544	41544	DOUILLE CPO DROITE	1,000
41567	41567	41567	1,000
41568	41568	SUPPORT DROIT	1,000
41789	41789	SUPPORT GAUCHE CPLT	1,000
41795	41795	SUPPORT GAUCHE CPLT	1,000
41805	41805	GUIDON SUP.	1,000
41808	41808	ENS.CROCHET	1,000
41809	41809	ENS.ENTRAINEUR	1,000
43042	43042	CABLE FREIN MOTEUR	1,000
43062	43062	MANETTE DE COMMANDE	1,000
43063	43063	GUIDE MANETTE GAZ	1,000
43064	43064	COUVERCLE MANETTE	1,000
43065	43065	RESSORT MANETTE	1,000
43066	43066	GUIDE MANETTE 3 VIT	1,000
43067	43067	GUIDE MANETTE GAZ	1,000
43081	43081	43081	1,000
43090	43090	BUTEE TENDEUR	1,000

Repère	Référence	Désignation	Quantité
43095	43095	*** Article remplacé ***	1,000
43096	43096	*** Article remplacé ***	1,000
43097	43097	*** Article remplacé ***	1,000
43098	43098	*** Article remplacé ***	1,000
43099	43099	DOUILLE 3 VITESSES	1,000
43324	43324	KIT G.MONOV.SERIE G	1,000
43325	43325	KIT G.3VIT.SERIE G	1,000
43326	43326	KIT D.GTFK1/M,GTFH2	1,000
43327	43327	KIT DROIT GTCH2M	1,000
43328	43328	KIT DROIT GTFB4M	1,000
71023	71023	VIS H M 6X50	1,000
71073	71073	ECROU AUTOFR.HM6	1,000
71096	71096	RDLE PL.B 6,4	1,000
71116	71116	VIS CB H M5X40	1,000
71279	71279	VIS B4.2-13 4.6	1,000
71301	71301	VIS CM HC M6X30,8.8	1,000
71302	71302	VIS H M6X55,8.8	1,000
71303	71303	VIS C HC M5X30,8.8	1,000
71305	71305	RDLE PLATE 5.5	1,000
71308	71308	ECROU H FR M5,8	1,000
71424	71424	CIRCLIPS 9,4	1,000

www.emc-motoculture.com

GTFK1M - GTFK1 - GTCH2M - GTFB4M - GTFH2 - 2000

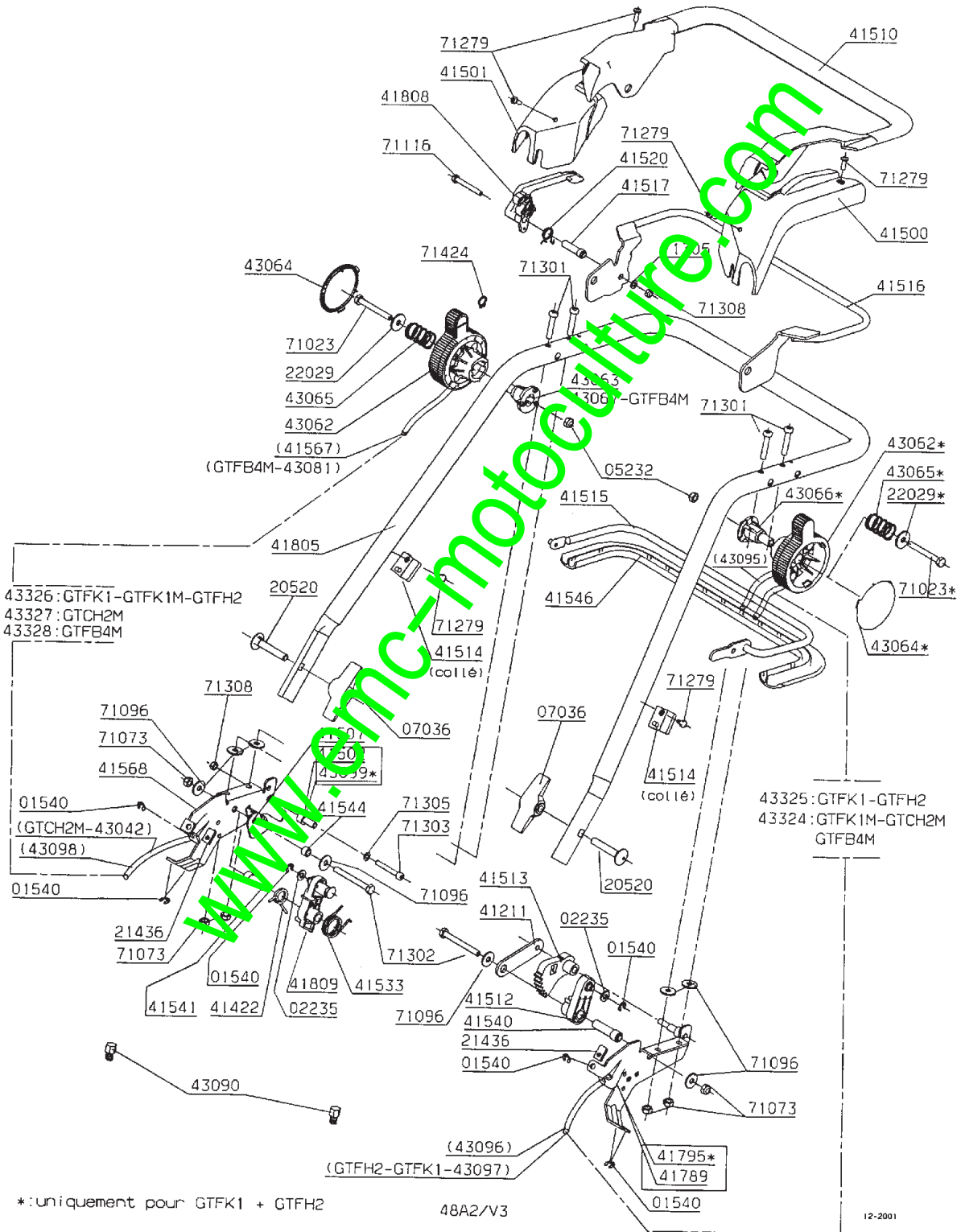

Repère	Référence	Désignation	Quantité
1540	1540	CIRCLIPS	1,000
2235	2235	RDLE PL.A 6,4	1,000
5232	5232	ECROU AUTOFREIN HM6	1,000
7036	7036	ECROU PAPILLON	1,000
20520	20520	VIS JAPY M8 X 45	1,000
21436	21436	ECROU NUL 530	1,000
22029	22029	RDLE PL.B 6,5	1,000
41211	41211	RENFORT ARCEAU	1,000
41422	41422	RESSORT DEVERROUILL	1,000
41500	41500	CACHE GAUCHE	1,000
41501	41501	CACHE DROIT	1,000
41502	41502	DOUILLE LOQUET	1,000
41507	41507	BUTEE ENTRAINEUR	1,000
41510	41510	REVETEMENT CPO	1,000
41512	41512	PIGNON AVANCE	1,000
41513	41513	SECTEUR CRANTE	1,000
41515	41515	ARCEAU AVANCE COMPLET	1,000
41516	41516	ARCEAU CPO COMPLET	1,000
41517	41517	DOUILLE CROCHET	1,000
41520	41520	RESSORT CROCHET	1,000
41529	41529	SUPPORT DROIT	1,000
41533	41533	RESSORT ENTRAINEUR	1,000
41540	41540	ARTICULATION CPO G	1,000
41541	41541	ARTICULATION CPO DR	1,000
41544	41544	DOUILLE CPO DROITE	1,000
41546	41546	REJET.ARCEAU AVANCE	1,000
41568	41568	SUPPORT DROIT	1,000
41581	41581	CABLE GAZ	1,000
41789	41789	SUPPORT GAUCHE CPLT	1,000
41795	41795	SUPPORT GAUCHE CPLT	1,000
41805	41805	GUIDON SUP.	1,000
41808	41808	ENS.CROCHET	1,000
41809	41809	ENS.ENTRAINEUR	1,000
43062	43062	MANETTE DE COMMANDE	1,000
43063	43063	GUIDE MANETTE GAZ	1,000
43064	43064	COUVERCLE MANETTE	1,000
43065	43065	RESSORT MANETTE	1,000
43066	43066	GUIDE MANETTE 3 VIT	1,000
43067	43067	GUIDE MANETTE GAZ	1,000
43090	43090	BUTEE TENDEUR	1,000
43099	43099	DOUILLE 3 VITESSES	1,000

Repère	Référence	Désignation	Quantité
43105	43105	BUTEE CABLE	1,000
43106	43106	CABLE GAZ B4	1,000
43109	43109	CABLE CDE 3 VIT.	1,000
43111	43111	CABLE FREIN MOTEUR	1,000
43112	43112	CABLE DEMARREUR	1,000
43132	43132	CABLE EMBR.FR.LAME	1,000
43133	43133	CABLE AVANCE+BUTEE	1,000
43134	43134	CABLE AVANCE+BUTEE	1,000
71023	71023	VIS H M 6X50	1,000
71073	71073	ECROU AUTOFR.HM6	1,000
71096	71096	RDLE PL.B 6,4	1,000
71116	71116	VIS CB H M5X40	1,000
71279	71279	VIS B4.2-13 4.6	1,000
71301	71301	VIS CM HC M6X30,8.8	1,000
71302	71302	VIS H M6X55,8.8	1,000
71303	71303	VIS C HC M5X35,8.8	1,000
71305	71305	RDLE PLATE 5.5	1,000
71308	71308	ECROU H FR M5,8	1,000
71424	71424	CIRCLIPS 9X1	1,000

[www.emc-motoculture.com](http://www.emc-motoculture.com)

GTFK1 - GTFH2 - GTCH2M - GTFB4M - GTCB4M - GTAB4M - 2002

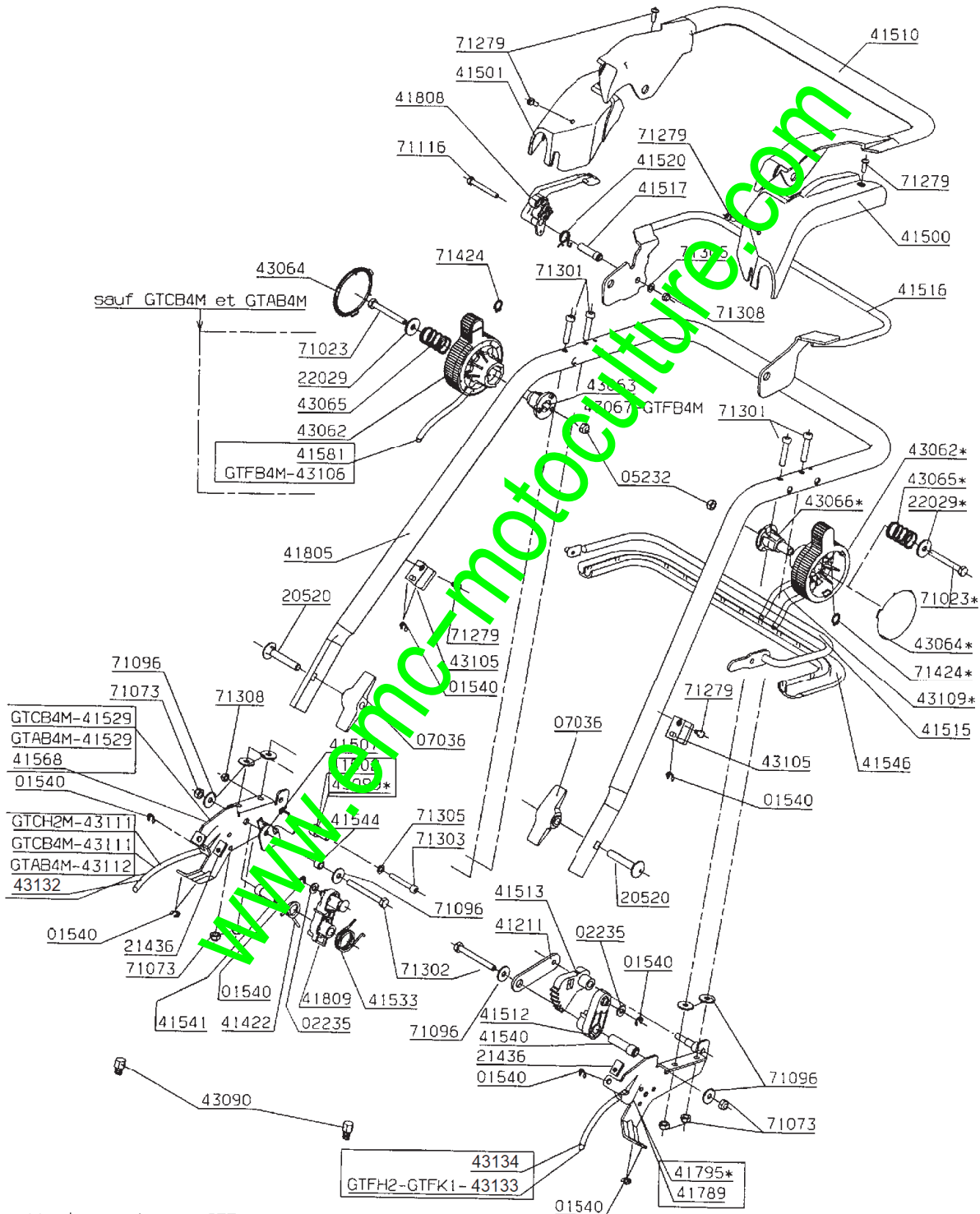

\*:uniquement pour GTFK1 + GTFH2

48A3/V1

12-2001

Repère	Référence	Désignation	Quantité
1540	1540	CIRCLIPS	1,000
24684	24684	ANNEAU TRUARC 8	1,000
41020	41020	PATTE SECU.DEFLECT.	1,000
41406	41406	VERROU GUIDON	1,000
41411	41411	BAGUE VERROU	1,000
41412	41412	PLATINE GAUCHE	1,000
41413	41413	RESSORT TRACTION	1,000
41414	41414	PLATINE DROITE	1,000
41416	41416	SUPPORT LANCEUR	1,000
41424	41424	RESSORT SECU.DEF.99	1,000
41429	41429	CROCHET SECU.DEF.99	1,000
41430	41430	ENTRETOISE SECU.DEF	1,000
41431	41431	GUIDE CABLE	1,000
41432	41432	BUTEE SECU.DEFL.OO	1,000
41514	41514	BUTEE GAINÉ DOUBLE	1,000
43004	43004	DEFLECTEUR	1,000
43011	43011	AXE DE LIAISON	1,000
43015	43015	RENFORT DEFLECTEUR	1,000
43056	43056	TOLE DE RENFORT	1,000
43071	43071	SUPPORT DE GUIDAGE	1,000
43075	43075	BAGUE ARTICULATION	1,000
43085	43085	BUTEE REGLABLE	1,000
43094	43094	BUTEE CABLE 3 VIT.	1,000
43252	43252	GUIDON.INF.COMPLET	1,000
43253	43253	TUBE COMPLET	1,000
43258	43258	DOUILLE SECU.DEFLEC	1,000
43285	43285	BRAS GAUCHE COMPLET	1,000
43286	43286	BRAS DROIT COMPLET	1,000
71073	71073	ECROU AUTOFR.HM6	1,000
71074	71074	ECROU AUTOFR.HM8	1,000
71084	71084	VIS H M 6X16 DIN933	1,000
71096	71096	RDLE PL.B 6,4	1,000
71232	71232	VIS CHC 6X12-8.8	1,000
71273	71273	VIS H M8X25.8.8	1,000
71274	71274	RDLE PLATE B8.4	1,000
71276	71276	VIS EJPT K 70X20	1,000
71278	71278	VIS C HC M6X16,8.8	1,000
71279	71279	VIS B4.2-13 4.6	1,000
71299	71299	VIS EJPT KA 40X14	1,000
71308	71308	ECROU H FR M5,8	1,000
71351	71351	VIS EPAULEE 5X10	1,000



Repère	Référence	Désignation	Quantité
71380	71380	VIS TH M6X35 DIN931	1,000

[www.emc-motoculture.com](http://www.emc-motoculture.com)



GTFK1M - GTFK1 - GTFB4M - GTCH2M - GTFH2 - 1999/2001

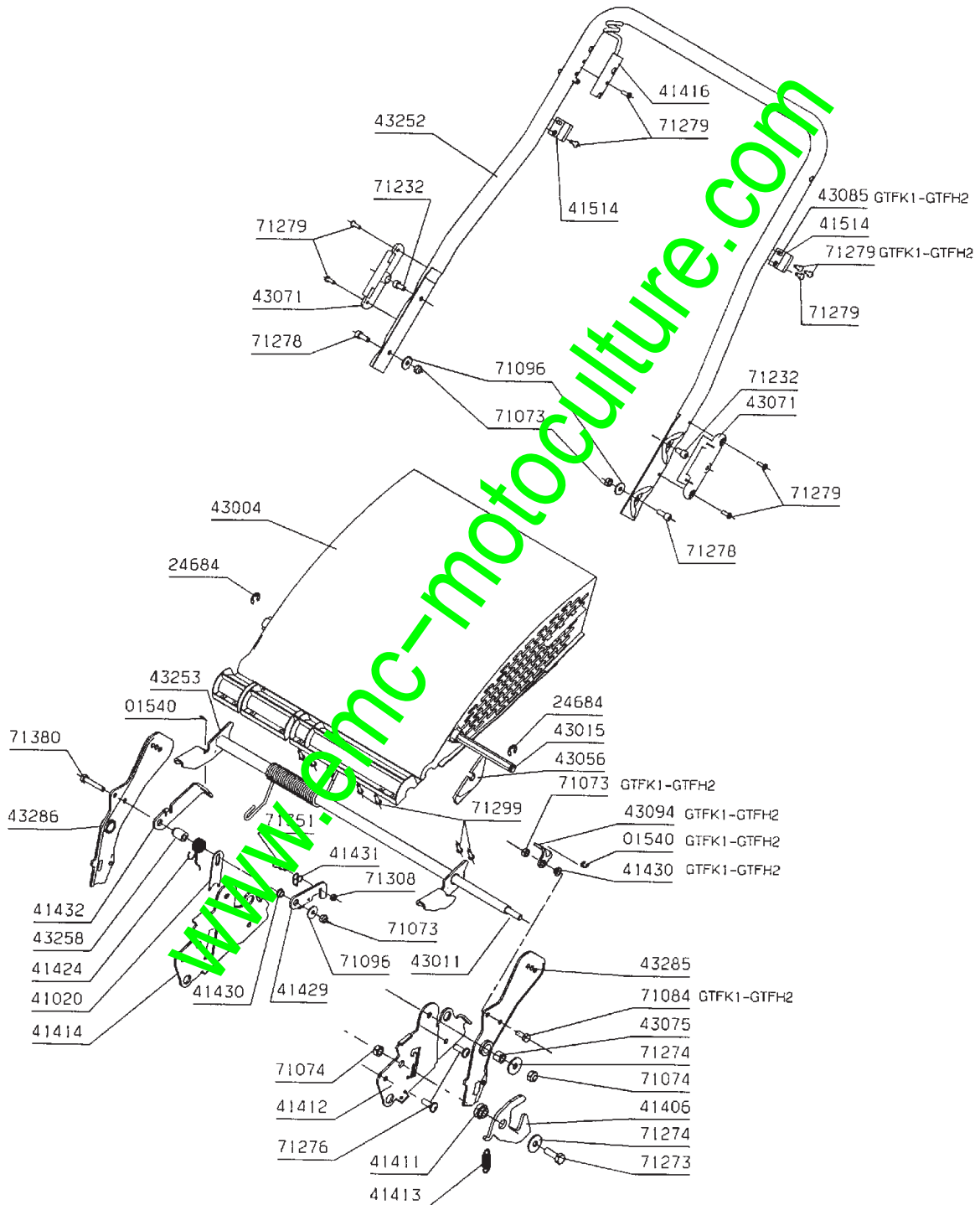

48A10/V3

12-2001

Repère	Référence	Désignation	Quantité
1540	1540	CIRCLIPS	1,000
5508	5508	RONDELLE 029X2	1,000
20597	20597	ENTRETOISE CABLE	1,000
24129	24129	GAINÉ SPIRA.PEDIA.4	1,000
24684	24684	ANNEAU TRUARC 8	1,000
41020	41020	PATTE SECU.DEFLECT.	1,000
41408	41408	RESSORT TORSION	1,000
41411	41411	BAGUE VERROU	1,000
41412	41412	PLATINE GAUCHE	1,000
41413	41413	RESSORT TRACTION	1,000
41414	41414	PLATINE DROITE	1,000
41416	41416	SUPPORT LANCEUR	1,000
41424	41424	RESSORT SECU.DEF.99	1,000
41426	41426	RESSORT TORSION	1,000
41429	41429	CROCHET SECU.DEF.99	1,000
41430	41430	ENTRETOISE SECU.DEF	1,000
41431	41431	GUIDE CABLE	1,000
41432	41432	BUTÉE SECU.DEFLECT	1,000
41433	41433	VERROU GUIDON 2001	1,000
43004	43004	DEFLECTEUR	1,000
43011	43011	AXE DE LIANSON	1,000
43015	43015	RENEFORT DEFLECTEUR	1,000
43056	43056	TOILE DE RENFORT	1,000
43071	43071	SUPPORT DE GUIDAGE	1,000
43075	43075	BAGUE ARTICULATION	1,000
43085	43085	BUTÉE REGLABLE	1,000
43094	43094	BUTÉE CABLE 3 VIT.	1,000
43105	43105	BUTÉE CABLE	1,000
43114	43114	GAINÉ SPI.D9 1METRE	1,000
43252	43252	GUIDON.INF.COMPLET	1,000
43253	43253	TUBE COMPLET	1,000
43258	43258	DOUILLE SECU.DEFLEC	1,000
43293	43293	BRAS G.CPLT.2001	1,000
43294	43294	BRAS D.CPLT.2001	1,000
71050	71050	VIS EJOT-PT KA40X12	1,000
71073	71073	ECROU AUTOFR.HM6	1,000
71074	71074	ECROU AUTOFR.HM8	1,000
71084	71084	VIS H M 6X16 DIN933	1,000
71096	71096	RDLE PL.B 6,4	1,000
71232	71232	VIS CHC 6X12-8.8	1,000
71273	71273	VIS H M8X25,8.8	1,000

Repère	Référence	Désignation	Quantité
71274	71274	RDLE PLATE B8.4	1,000
71276	71276	VIS EJPT K 70X20	1,000
71278	71278	VIS C HC M6X16,8.8	1,000
71279	71279	VIS B4.2-13 4.6	1,000
71299	71299	VIS EJPT KA 40X14	1,000
71308	71308	ECROU H FR M5,8	1,000
71351	71351	VIS EPAULEE 5X10	1,000
71380	71380	VIS TH M6X35 DIN931	1,000

[www.emc-motoculture.com](http://www.emc-motoculture.com)

GTKF1 - GTFH2 - GTCH2M - GTFB4M - GTCB4M - GTAB4M - 2002

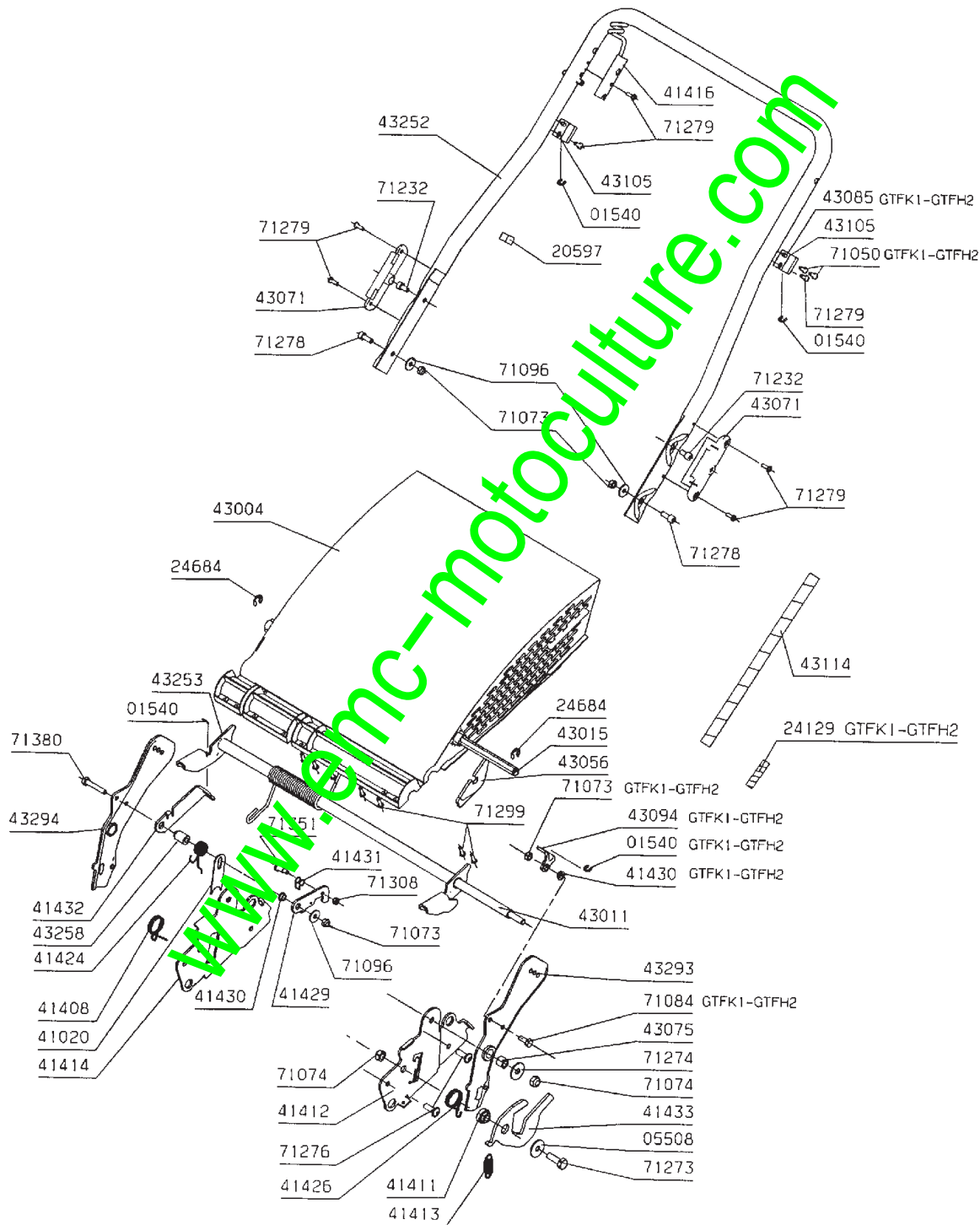

48A15/V1

12-2001

Repère	Référence	Désignation	Quantité
1607	1607	ECROU AUTOFREIN HM5	1,000
5015	5015	DOUILLE A AIGUILLES	1,000
5019	5019	BAGUE AXE ROUE	1,000
5323	5323	PIGNON CREUX	1,000
5329	5329	RESSORT RAPPEL CLIQ	1,000
5733	5733	ROUE LIBRE DROITE	1,000
5734	5734	ROUE LIBRE GAUCHE	1,000
6011	6011	RONDELLE	1,000
7094	7094	RDLE PLATE B 4,3	1,000
9022	9022	ROULEMENT A BILLES	1,000
9034	9034	ENTRETOISE PLASTIQ	1,000
20533	20533	ROULEMENT A BILLES	1,000
20536	20536	RDLE RESS. B12	1,000
20537	20537	BAGUE DE ROUE	1,000
20559	20559	CIRCLIPS 10	1,000
20561	20561	RDELLE RESS. A10	1,000
21036	21036	RDLE PL. A10,5	1,000
21270	21270	RDLE PL.B 6,4	1,000
21481	21481	RDLE PLATE 7 5,5	1,000
21609	21609	GOUPILLE SPIX22	1,000
21655	21655	BAGUE D'ETANCHEITE	1,000
22455	22455	POULIE REDUCTEUR	1,000
23631	23631	COURROIE 46 STD TH.	1,000
24067	24067	RDLE DE MAINTIEN	1,000
24087	24087	RDLE DE PROTECTION	1,000
24132	24132	RONDELLE AXE ROUE	1,000
24410	24410	KIT ROUE AR.TR.51	1,000
24661	24661	*** Article remplacé ***	1,000
24692	24692	RDLE D'ETANCHEITE	1,000
24804	24804	FLASQUE ROUE D.200	1,000
24806	24806	ROUE D200 RLT BILLE	1,000
41552	41552	FAUSSE MAILLE D=3	1,000
41654	41654	TUBE DE PROTECTION	1,000
43018	43018	ENTRETOISE10X1.5X2	1,000
43020	43020	RLT A BILLES D12/32	1,000
43024	43024	ENTRETOISE DISQUE	1,000
43028	43028	DISQUE D'INDEXAGE	1,000
43029	43029	INDICATEUR HDC	1,000
43030	43030	RESSORT COMPENSATIO	1,000
43031	43031	RLE MOTEUR	1,000
43032	43032	TUBE PROTECTION AXE	1,000

Repère	Référence	Désignation	Quantité
43033	43033	BAGUE 12/15/25 BP25	1,000
43035	43035	POULIE 3 VIT.	1,000
43036	43036	RESSORT DE TENSION	1,000
43038	43038	BUTEE DE GAINÉ 3 VI	1,000
43039	43039	LEVIER 3 VIT.	1,000
43054	43054	RLE FIX.TIGE ARR.	1,000
43055	43055	SUPPORT PALIER DISQ	1,000
43069	43069	COURROIE SPZ812	1,000
43072	43072	LEVIER EMBRAYAGE	1,000
43073	43073	ENTRETOISE CLIQUET	1,000
43257	43257	TIGE LIAISON AV/ARR	1,000
43263	43263	HDC ARR TRACTEE CPL	1,000
43265	43265	ENSEMBLE HDC AVANT	1,000
43266	43266	ENS.MANETTE HDC	1,000
43268	43268	REDUCTEUR A DISQUE	1,000
43302	43302	ROUE LIBRE DROITE	1,000
43329	43329	REDUCT.3VIT.SERIE G	1,000
71021	71021	VIS FHC/90 M6X12	1,000
71048	71048	VIS EJOT-PT K 40X10	1,000
71054	71054	VIS EJOT 50X12	1,000
71060	71060	VIS J M6X25	1,000
71069	71069	VIS J M6X16	1,000
71072	71072	VIS CHC M6X10	1,000
71073	71073	ECHOU AUTOFR.HM6	1,000
71088	71088	GOUPIL.SPI.3X22	1,000
71096	71096	RDLE PL.B 6,4	1,000
71188	71188	GOUPIL.ELAST. 4-26	1,000
71212	71212	VIS F X M6-12,AF	1,000
71222	71222	VIS FHC/90 M6X12	1,000
71252	71252	VIS TH M5X45	1,000
71271	71271	VIS EJ-PT DG 60X12	1,000
71275	71275	VIS EJPT K 50X45	1,000
71381	71381	VIS F HC M6-20,8.8	1,000

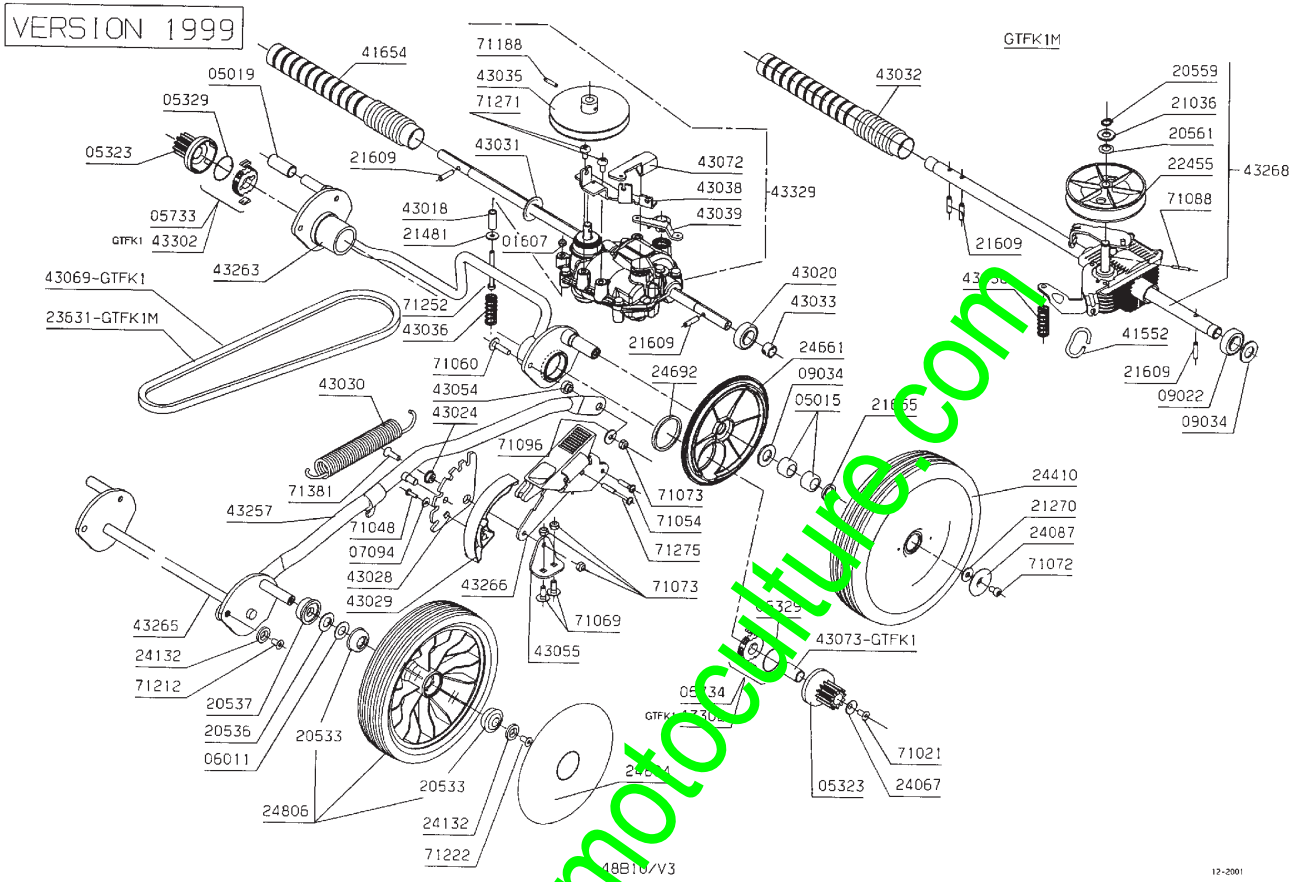

[www.emc-motoculture.com](http://www.emc-motoculture.com)

Repère	Référence	Désignation	Quantité
1540	1540	CIRCLIPS	1,000
1607	1607	ECROU AUTOFREIN HM5	1,000
5323	5323	PIGNON CREUX	1,000
5329	5329	RESSORT RAPPEL CLIQ	1,000
5733	5733	ROUE LIBRE DROITE	1,000
5734	5734	ROUE LIBRE GAUCHE	1,000
6011	6011	RONDELLE	1,000
7094	7094	RDLE PLATE B 4,3	1,000
9022	9022	ROULEMENT A BILLES	1,000
9034	9034	ENTRETOISE PLASTIQ	1,000
20533	20533	ROULEMENT A BILLES	1,000
20536	20536	RDLE RESS. B12	1,000
20537	20537	BAGUE DE ROUE	1,000
20559	20559	CIRCLIPS 10	1,000
20561	20561	RDELLE RESS. A10	1,000
21036	21036	RDLE PL. A10,5	1,000
21481	21481	RDLE PLATE A 5,3	1,000
21609	21609	GOUPILLE SPIX22	1,000
22455	22455	POULIE REDUCTEUR	1,000
24067	24067	RDLE DE MAIN BIEN	1,000
24132	24132	RONDELLE AXE ROUE	1,000
24412	24412	ROUE NG51 TR.JAUNE	1,000
24692	24692	RDLE D'ETANCHEITE	1,000
24804	24804	PLAQUE ROUE D.200	1,000
24806	24806	ROUE D200 RLT BILLE	1,000
41552	41552	FAUSSE MAILLE D=3	1,000
41654	41654	TUBE DE PROTECTION	1,000
42097	42097	ENTRETOISE	1,000
43018	43018	ENTRETOISE10X1.5X2	1,000
43020	43020	RLT A BILLES D12/32	1,000
43024	43024	ENTRETOISE DISQUE	1,000
43028	43028	DISQUE D'INDEXAGE	1,000
43029	43029	INDICATEUR HDC	1,000
43030	43030	RESSORT COMPENSATIO	1,000
43031	43031	RLE MOTEUR	1,000
43032	43032	TUBE PROTECTION AXE	1,000
43033	43033	BAGUE 12/15/25 BP25	1,000
43036	43036	RESSORT DE TENSION	1,000
43038	43038	BUTEE DE GAINÉ 3 VI	1,000
43039	43039	LEVIER 3 VIT.	1,000
43047	43047	POULIE DP.91.5	1,000



Repère	Référence	Désignation	Quantité
43054	43054	RLE FIX.TIGE ARR.	1,000
43055	43055	SUPPORT PALIER DISQ	1,000
43069	43069	COURROIE SPZ812	1,000
43072	43072	LEVIER EMBRAYAGE	1,000
43082	43082	COURROIE SPZ 850	1,000
43115	43115	JOINT TORIQUE	1,000
43187	43187	CACHE ROUE ARR.TR.N	1,000
43257	43257	TIGE LIAISON AV/ARR	1,000
43265	43265	ENSEMBLE HDC AVANT	1,000
43266	43266	ENS.MANETTE HDC	1,000
43268	43268	REDUCTEUR A DISQUE	1,000
43292	43292	HDC AR.TR.CPLT.2001	1,000
43301	43301	ROUE LIBRE GAUCHE	1,000
43302	43302	ROUE LIBRE DROITE	1,000
43329	43329	REDUCT.3VIT.SERIE G	1,000
71016	71016	RDLE 16X22X1	1,000
71021	71021	VIS FHC/90 M6X12	1,000
71048	71048	VIS EJOT-PT K 40X40	1,000
71054	71054	VIS EJOT K50X22	1,000
71060	71060	VIS J M 6X25	1,000
71069	71069	VIS J M 6X15	1,000
71073	71073	ECROU AUTOFR.HM6	1,000
71088	71088	COUPIL.SPI.3X22	1,000
71096	71096	RDLE PL.B 6,4	1,000
71188	71188	COUPIL.ELAST. 4-26	1,000
71212	71212	VIS F X M6-12,AF	1,000
71222	71222	VIS FHC/90 M6X12	1,000
71252	71252	VIS TH M5X45	1,000
71271	71271	VIS EJ-PT DG 60X12	1,000
71275	71275	VIS EJPT K 50X45	1,000
71364	71364	VIS TCB INBUS M6X16	1,000
71381	71381	VIS F HC M6-20,8.8	1,000
71425	71425	VIS TH M6X14 DIN933	1,000

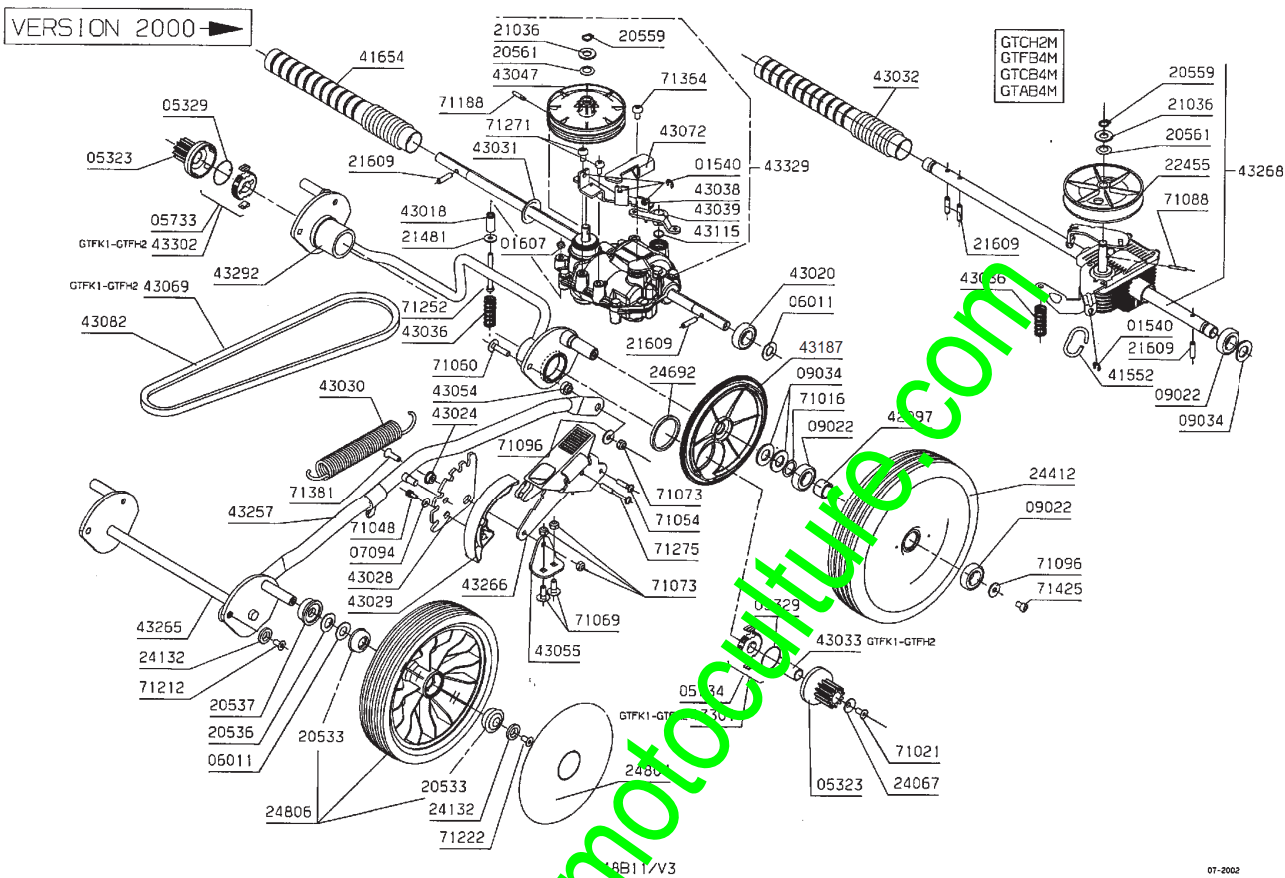

www.emc-motooltje.com

Repère	Référence	Désignation	Quantité
1540	1540	CIRCLIPS	1,000
1830	1830	JOINT TORIQUE	1,000
5070	5070	POULIE PR EMBRAYAGE	1,000
5203	5203	RESSORT RAPPEL	1,000
5232	5232	ECROU AUTOFREIN HM6	1,000
6178	6178	ECROU 'RAPID'	1,000
21481	21481	RDLE PLATE A 5,3	1,000
21585	21585	VIS TOLE BZ 4,2X9,5	1,000
22029	22029	RDLE PL.B 6,5	1,000
23623	23623	PLOT RESSORT	1,000
24602	24602	SEMELLE NG46/51	1,000
41547	41547	ENTRETOISE ROULETTE	1,000
41562	41562	SUPPORT ROULETTE	1,000
43005	43005	CACHE AILE GAUCHE	1,000
43006	43006	CACHE AILE DROIT	1,000
43007	43007	CACHE AVANT	1,000
43010	43010	FERMETURE CARCASSE	1,000
43013	43013	CACHE COURFOIE	1,000
43021	43021	BRIDE POUR MANCHON	1,000
43050	43050	CACHE EMB.FR LAME	1,000
43113	43113	BUTEE CABLE DEMARR.	1,000
43310	43310	ENSEMBLE CARCASSE	1,000
71048	71048	VIS EJOT-PT KA40X10	1,000
71051	71051	VIS EJOT-PT KA40X14	1,000
71074	71074	ECROU AUTOFR.HM8	1,000
71075	71075	RDLE PLATE M 6N	1,000
71096	71096	RDLE PL.B 6,4	1,000
71161	71161	VIS CHC M6X25	1,000
71187	71187	RDLE PL.A 8.4 ST	1,000
71206	71206	VIS EJOT-PT KA50X16	1,000
71276	71276	VIS EJPT K 70X20	1,000
71279	71279	VIS B4.2-13 4.6	1,000
71285	71285	VIS CHC M 6X20	1,000
71299	71299	VIS EJPT KA 40X14	1,000
71311	71311	RDLE 8-30-2.5	1,000
71349	71349	VIS AUTOT.CM 5X12	1,000
71365	71365	VIS EJ WN1451 60X20	1,000
71377	71377	VIS H M8-45 8.8	1,000

GTFK1 - GTFH2 -GTCH2M - GTFB4M - GTCB4M - GTAB4M

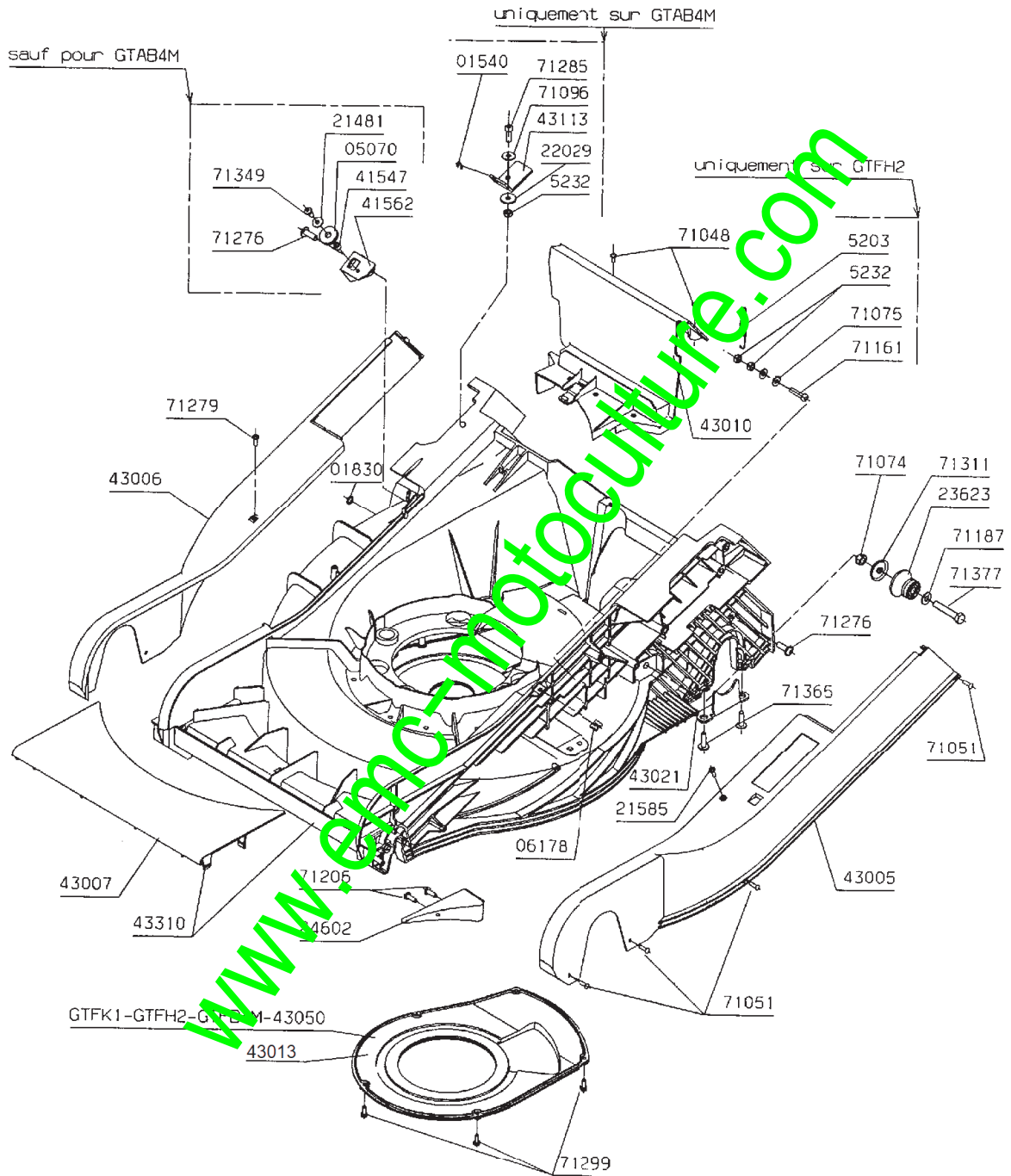

Repère	Référence	Désignation	Quantité
2021	2021	ECROU AUTOFREIN HM8	1,000
2244	2244	RONDELLE GROWER	1,000
5353	5353	VIS HC BOUT POINTU	1,000
7035	7035	RDLE PL.B 8,4	1,000
7337	7337	CLAVET.15,72X4X6,5	1,000
7341	7341	RONDELLE DE SERRAGE	1,000
7342	7342	BOULON SERRAGE LAME	1,000
20521	20521	RONDELLE L 8N	1,000
23616	23616	ACCOUPLLEMENT	1,000
23864	23864	MOT.B&S QU.XTL50 FR	1,000
23867	23867	MOT.HONDAGCV160E FR	1,000
24616	24616	ACCOUPLLEMENT D.22,2	1,000
24827	24827	GOUJON M10/M8 FIXAT	1,000
43008	43008	VENTILAT.MOTEUR FR.	1,000
43009	43009	SUPPORT MOTEUR	1,000
43016	43016	POULIE MOTEUR DB 63	1,000
43017	43017	ELEMENT ANTI-VIBRAT	1,000
43068	43068	RDLE.MOT.ISOLANTE	1,000
43102	43102	MOT.B/S XNF50 QUANT	1,000
71127	71127	CLAV.4,8X6,5X15,72	1,000
71382	71382	VIS J M3-65,8 8	1,000
GX48	GX48	LAME 48	1,000
TK51	TK51	*** Article remplacé ***	1,000

www.emc-motoculture.com

GTAB4M. MOT B/S XTL50 QUANT.TNM. réf:43102  
 GTCB4M. MOT B/S QUANT XTL50 réf:23864  
 GTCH2M MOTEUR HONDA GCV160 - REF 23867

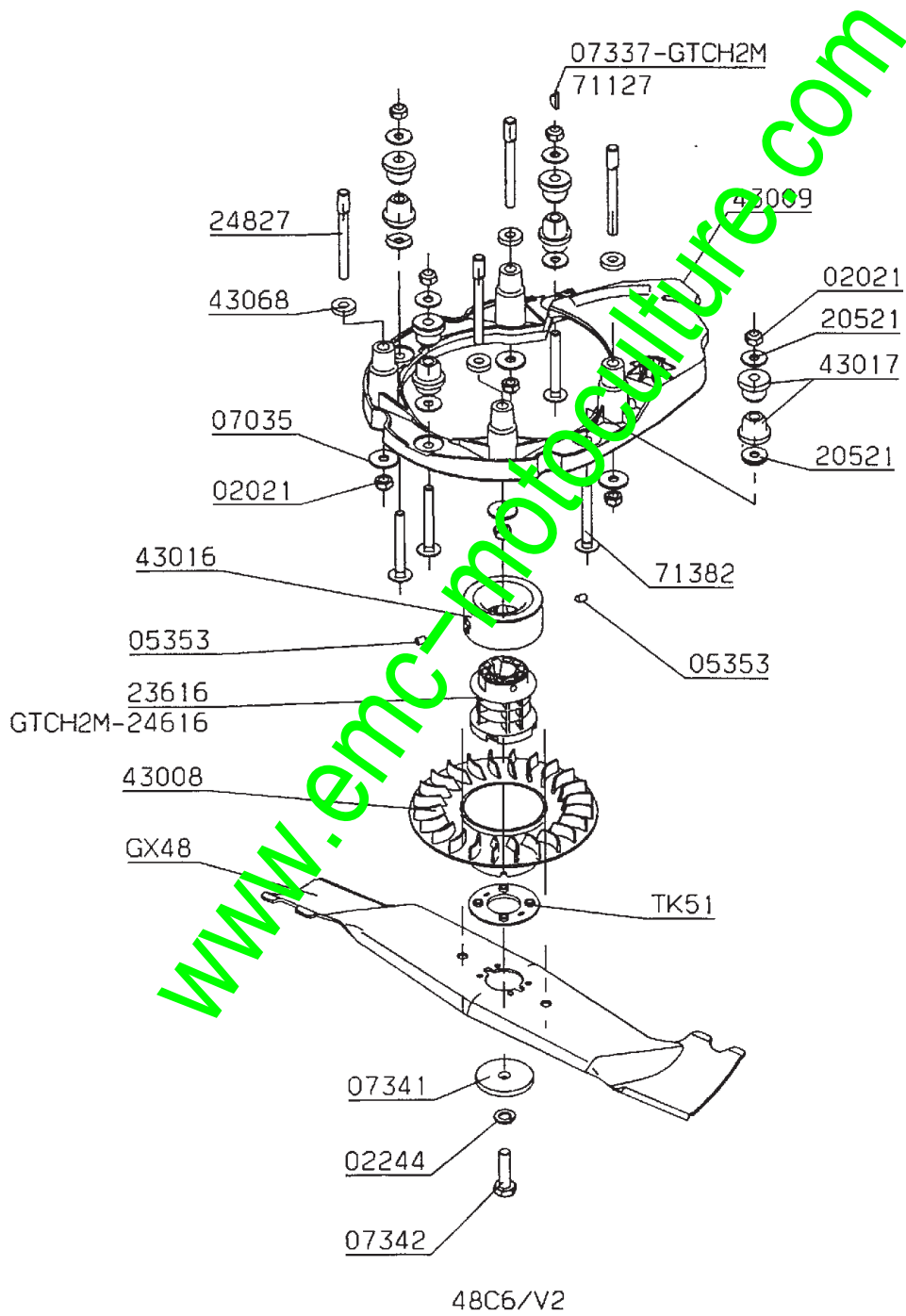

Repère	Référence	Désignation	Quantité
1540	1540	CIRCLIPS	1,000
1607	1607	ECROU AUTOFREIN HM5	1,000
5323	5323	PIGNON CREUX	1,000
5329	5329	RESSORT RAPPEL CLIQ	1,000
5733	5733	ROUE LIBRE DROITE	1,000
5734	5734	ROUE LIBRE GAUCHE	1,000
6011	6011	RONDELLE	1,000
7094	7094	RDLE PLATE B 4,3	1,000
9022	9022	ROULEMENT A BILLES	1,000
9034	9034	ENTRETOISE PLASTIQ	1,000
20533	20533	ROULEMENT A BILLES	1,000
20536	20536	RDLE RESS. B12	1,000
20537	20537	BAGUE DE ROUE	1,000
20559	20559	CIRCLIPS 10	1,000
20561	20561	RDELLE RESS. A10	1,000
21036	21036	RDLE PL. A10,5	1,000
21481	21481	RDLE PLATE A 5,3	1,000
21609	21609	GOUPILLE SPIXZ	1,000
22455	22455	POULIE REDUCTEUR	1,000
24067	24067	RDLE DE MAINIEN	1,000
24132	24132	RONDELLE AXE ROUE	1,000
24412	24412	ROUE NG51 TR.JAUNE	1,000
24661	24661	*** Article remplacé ***	1,000
24692	24692	RDLE D'ETANCHEITE	1,000
24804	24804	PLASQUE ROUE D.200	1,000
24806	24806	ROUE D200 RLT BILLE	1,000
41552	41552	FAUSSE MAILLE D=3	1,000
41654	41654	TUBE DE PROTECTION	1,000
42097	42097	ENTRETOISE	1,000
43018	43018	ENTRETOISE10X1.5X2	1,000
43020	43020	RLT A BILLES D12/32	1,000
43024	43024	ENTRETOISE DISQUE	1,000
43028	43028	DISQUE D'INDEXAGE	1,000
43029	43029	INDICATEUR HDC	1,000
43030	43030	RESSORT COMPENSATIO	1,000
43031	43031	RLE MOTEUR	1,000
43032	43032	TUBE PROTECTION AXE	1,000
43033	43033	BAGUE 12/15/25 BP25	1,000
43036	43036	RESSORT DE TENSION	1,000
43038	43038	BUTEE DE GAINE 3 VI	1,000
43039	43039	LEVIER 3 VIT.	1,000

Repère	Référence	Désignation	Quantité
43047	43047	POULIE DP.91.5	1,000
43054	43054	RLE FIX.TIGE ARR.	1,000
43055	43055	SUPPORT PALIER DISQ	1,000
43069	43069	COURROIE SPZ812	1,000
43072	43072	LEVIER EMBRAYAGE	1,000
43082	43082	COURROIE SPZ 850	1,000
43115	43115	JOINT TORIQUE	1,000
43257	43257	TIGE LIAISON AV/ARR	1,000
43265	43265	ENSEMBLE HDC AVANT	1,000
43266	43266	ENS.MANETTE HDC	1,000
43268	43268	REDUCTEUR A DISQUE	1,000
43292	43292	HDC AR.TR.CPLT.2001	1,000
43301	43301	ROUE LIBRE GAUCHE	1,000
43302	43302	ROUE LIBRE DROITE	1,000
43329	43329	REDUCT.3VIT.SERIE G	1,000
71016	71016	RDLE 16X22X1	1,000
71021	71021	VIS FHC/90 M6X12	1,000
71048	71048	VIS EJOT-PT K 40X40	1,000
71054	71054	VIS EJOT K50X22	1,000
71060	71060	VIS J M 6X25	1,000
71069	71069	VIS J M 6X15	1,000
71073	71073	ECROU AUTOFR.HM6	1,000
71088	71088	COUJIL.SPI.3X22	1,000
71096	71096	RDLE PL.B 6,4	1,000
71188	71188	COUJIL.ELAST. 4-26	1,000
71212	71212	VIS F X M6-12,AF	1,000
71222	71222	VIS FHC/90 M6X12	1,000
71252	71252	VIS TH M5X45	1,000
71271	71271	VIS EJ-PT DG 60X12	1,000
71275	71275	VIS EJPT K 50X45	1,000
71364	71364	VIS TCB INBUS M6X16	1,000
71381	71381	VIS F HC M6-20,8.8	1,000
71425	71425	VIS TH M6X14 DIN933	1,000



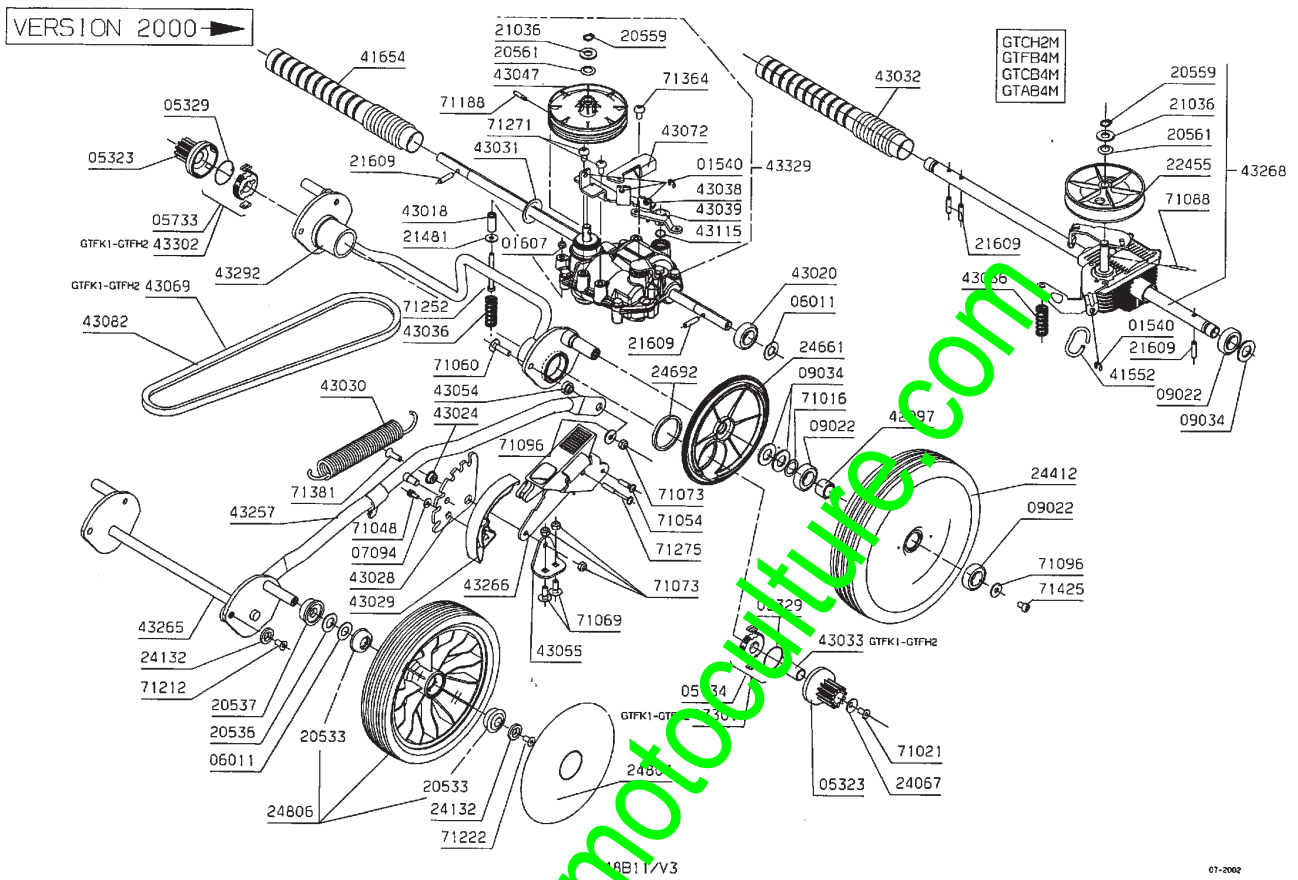

www.emc-motocultures.com

Repère	Référence	Désignation	Quantité
7094	7094	RDLE PLATE B 4,3	1,000
20555	20555	VIS SANS FIN	1,000
20556	20556	GOUPIL.SPI.3 X 15	1,000
20558	20558	BAGUE C10/15 X 10	1,000
21609	21609	GOUPILLE SPI 5X22	1,000
24642	24642	RLT A BILLES SUP.	1,000
24776	24776	ENS.CLOCHE + ROUE	1,000
41051	41051	COUVERCLE BOITIER	1,000
41052	41052	BOITIER REDUCT.N.M.	1,000
41055	41055	AXE RAPIDE N.M.	1,000
41056	41056	BAGUE AUT.C15/19X20	1,000
41059	41059	BRAS DE COMMANDE	1,000
41060	41060	RESSORT RAPPEL EMBR	1,000
41094	41094	FOURCHETTE RD	1,000
41095	41095	RONDELLE DE BUTEE	1,000
41100	41100	ENS.DISQUES + BUTEE	1,000
41102	41102	BUTEE A AIGUILLES	1,000
41104	41104	ENTRAINEUR	1,000
41105	41105	RENFORT BOITIER	1,000
41110	41110	JOINT COUVERCLE	1,000
41116	41116	HUILE ZOLLA 60ML	1,000
41821	41821	BUTEE AIGUILLES+RLE	1,000
41822	41822	ENS.AXE POUSSOIR	1,000
42095	42095	SUPPORT	1,000
43034	43034	AXE LENT 48 RD	1,000
43120	43120	POULIE DP.89	1,000
43268	43268	REDUCTEUR A DISQUE	1,000
71211	71211	VIS EJ-PT DG 50X16	1,000
71213	71213	VIS SF PLUS M4X10	1,000
71217	71217	JOINT TORIQUE 15X2	1,000
71218	71218	JOINT LEVRE 10X18X4	1,000
71219	71219	JOINT LEVRE 15X21X5	1,000
71220	71220	JOINT TORIQUE	1,000
71244	71244	VIS EJ-PT DG 50X20	1,000

OW4811

**Réducteur à disques 48 monovitesse**  
**GTB - GTFD1M - GTFB4M - GTAB4M - GTCB4M - GTCH2M - GTEB5M**

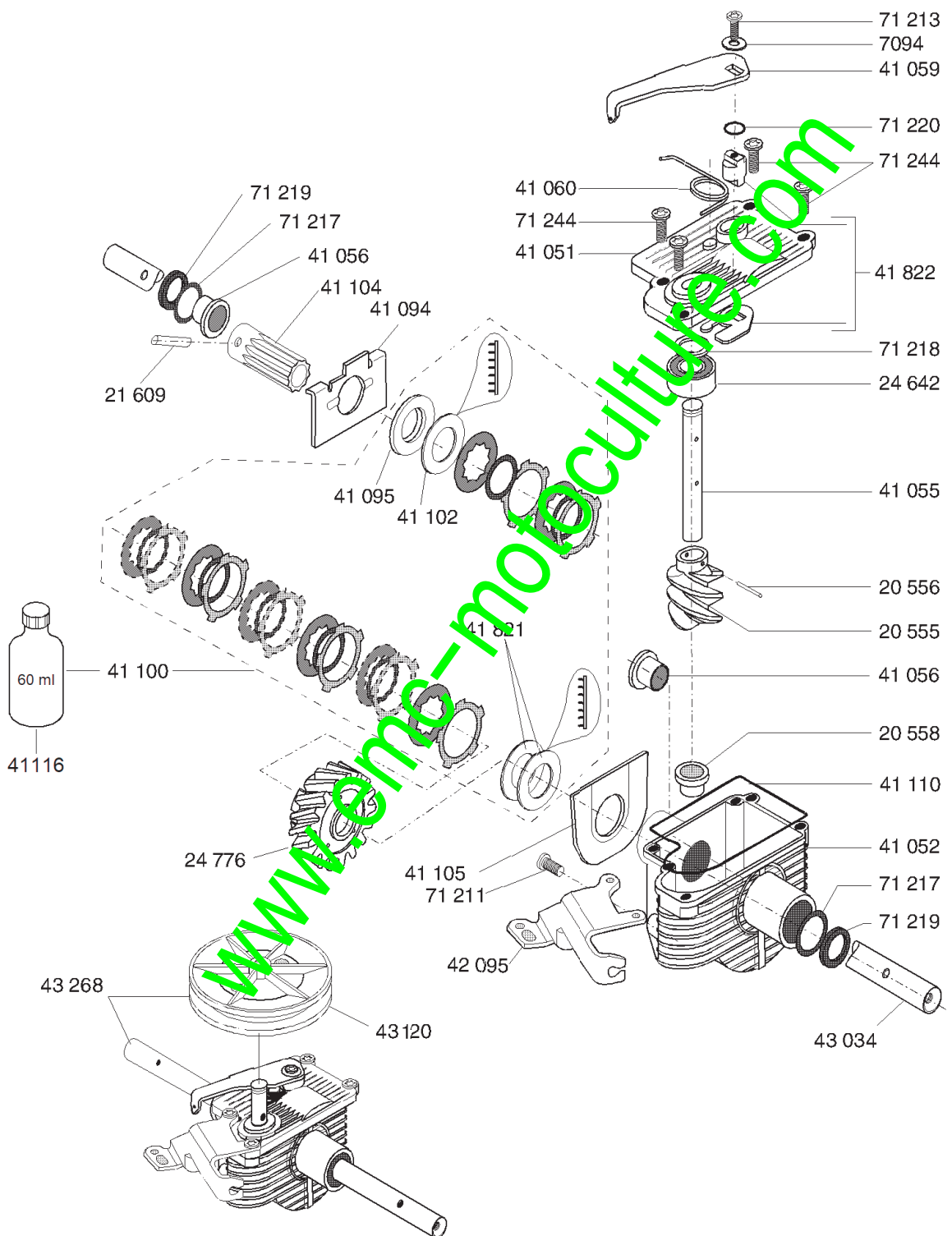

12/2020

Repère	Référence	Désignation	Quantité
1607	1607	ECROU AUTOFREIN HM5	1,000
21481	21481	RDLE PLATE A 5,3	1,000
41653	41653	TEMOIN DE REMPLISS.	1,000
41655	41655	POIGNEE PANIER	1,000
41657	41657	AXE POIGNEE	1,000
41658	41658	CROCHET PANIER D	1,000
41659	41659	CROCHET PANIER G	1,000
41660	41660	PROTECTION POIGNEE	1,000
43001	43001	PANIER INFERIEUR	1,000
43002	43002	PANIER SUPERIEUR	1,000
43003	43003	GRILLE PANIER	1,000
43046	43046	PANIER SUP.48 CPLT.	1,000
71233	71233	VIS J M5X16 DIN 603	1,000

[www.emc-motoculture.com](http://www.emc-motoculture.com)

PANIER 48

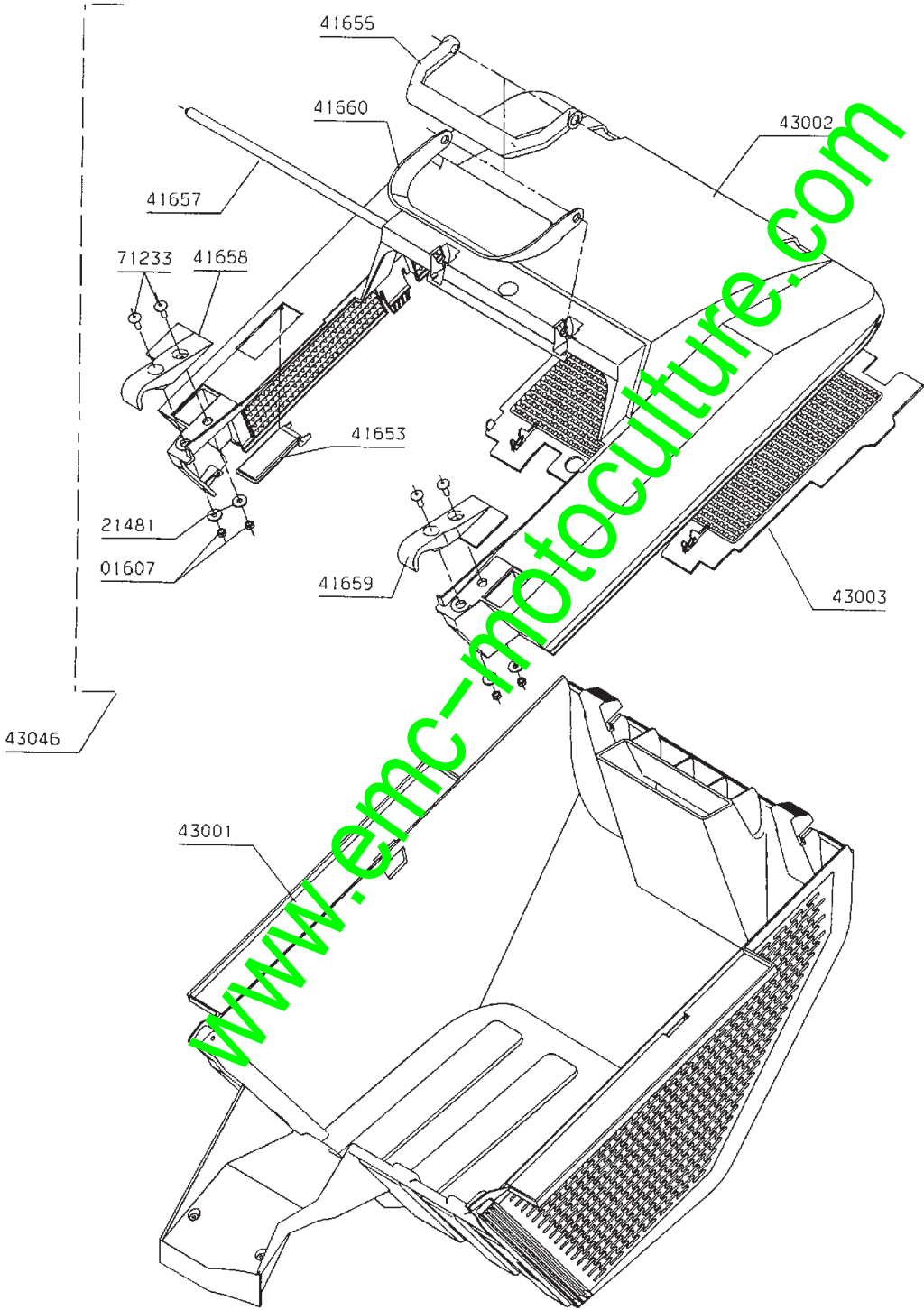

[www.emc-motoculture.com](http://www.emc-motoculture.com)