

Position	Numéro de pièce	Appellation I	Appellation II	Remarque
1	17932	SUPPORT RESERVOIR	STYLE-1	
2	17933A	SUPPORT TABLEAU DE BORD	17933A-0637	
3	710-3025	VIS	FINISH:MTD SPEC-100015	
5	710-0258	VIS	710-0258	
7	712-3010	ECROU HEX. 5/16-18:GR5	FINISH:MTD SPEC-100015	
8	725-0634	COMMUTATEUR	FINISH: SCHWARZ	
9	751-0603	BOUCHON RESERVOIR ESSENCE	FINISH: SCHWARZ	
10	726-0205	COLLIER DE SERRAGE DE BOYAU	FINISH:PHOS UND GELB LACKIERT	
11	726-0209	COLLIER	FINISH: SCHWARZ	
12	736-0119	RONDELLE	FINISH:MTD SPEC-100016	
13	725-0267	CONTACTEUR A CLE 5 FICHES	B.6PIN ERS.629-0234) 925-0267	
13A	725-1396	CONTACTEUR A CLE 6 FICHES	725-1396	
14	725-0201	CLE DE CONTACT	FINISH:VERNICKELT 079.12.707	
14A	725-1341B	CLE DE CONTACT SANS LOGO	725-1341B	
15	751-0553	RESERVOIR 5 L ENV.	FINISH:NATUR SIEHE ZG.	
16	751-0535-15	TUYAU / ESSENCE	751-0535 15" LANG	
17	761-0194	FREIN DE LAME	761-0194	
18	710-0134	VIS i TATE PLATE	FINISH:MTD SPEC-100015	
19	710-0793	VIS	710-0793	
20	783-0039A	SUPPORT SIEGE	783-0039A-0637/0665	
21	783-0354	BAC DE SIÈGE	400'96/783-0354-0638	
22	17704	ÛQUERRE FIXATION SIÈGE DROITE	17704-0637	
23	17703	ÛQUERRE DE FIXATION GAUCHE	17703-0637	
24	783-0384	PLAQUE D'ÉPAISSEUR DE COUPURE	VERZINKT	
24A	17553	PLAQUE D'ÉPAISSEUR DE COUPURE	VERZINKT	
24B	783-0872	PLAQUE HAUTEUR DE COUPE	7-FACH	
25	725-1705D	BATTERIE U1 12V/12AH	U1-7	
26	710-0817	VIS HEXAGONALE	FINISH:MTD SPEC-701-01002	
28	710-0726	VIS 5/16-12:0.750:HXINDWS	FINISH:MTD STD 701-01002	
29	710-1017	VIS	FINISH:MTD SPEC-100016	
30	710-0773	VIS HEXAGONALE	FINISH:MTD SPEC-100016 TYPE 1	
31	712-0287	ECROU HEXAGONAL 1/4-20:GR2	FINISH:701-01000 / 912-0287	
32	736-0607	RONDELLE	FINISH:MTD SPEC-100016	
33	783-0349	BOÎTIER DE BATTERIE	FINISH:LACKIERT SCHWARZ *	

Position	Numéro de pièce	Appellation I	Appellation II	Remarque
34	732-0588	RESSORT DE PRESSION	732-0588	
35	731-0871B	BOITIER DE BATTERIE	731-0871B	
36	736-0242	RONDELLE CONIQUE.340X.872X.060	FINISH:MTD SPEC-100016	
37	736-0329	RONDELLE GROWER	FINISH:SPEC-100016 24.8195.16	
40	736-0270	RONDELLE GROWER	FINISH:MTD SPEC-100016	
49	736-0217	RONDELLE GROWER	FINISH:MTD SPEC-100016	
50	712-0241	ECROU HEX.: 3/8-24:GR5	FINISH:MTD SPEC-100015	
53	723-0308C	MARCHE-PIED	Antirutschbelag	
53A	735-0252	TAPIS CAOUTCHOUC DROIT		
54	723-0309C	REVETEMT MARCHEPIED GAUCH	Antirutschbelag	
54A	735-0253	TAPIS CAOUTCHOUC GAUCHE	735-0253	
68	731-0511-81	GARNITURE	731-0511-81	
72	746-0616A	CABLE STARTER 58.4CM	746-0616A	
73	831-0823A	MANETTE GAZ AUTOPORTEE	931-0823A 400/700 o.Gaszug	
74	710-0779A	VIS	FINISH:701-01002 or 101616	
75	746-0776	CABLE ACCELERATEUR B&S	746-0776	
75A	746-0775	CABLE GAZ L 64 cm	746-0775 L 64 cm	
76	757-0363A	SIEGE INFERIEUR NOIR		dossier bas
76A	757-0360A	SIEGE DOSSIER MOYEN		dossier medium
76B	757-0348	VOIR 757-0348A	757-0348	dossier hault
76C	757-0364	SIEGE INFERIEUR JAUNE	757-0364	dossier bas
76D	757-0365	SIEGE JAUNE YARDMAN	757-0365	dossier medium
78	736-0159	RONDELLE -349 X 88X.06"	FINISH:MTD SPEC-100015	
79	722-0160	RONDELLE D'ATTÜNUATION	722-0160	
83	710-0227	VIS	FINISH:MTD SPEC-100016 TYPE 1	
84	725-1439	RESSORT SURETE DE SIEGE	SI.-SCHALTER SITZ:SPEC-100015	
85	732-0581B	RESSORT DE TRACTION	732-0581B	
86	17239A	LEVIER / CONTACT	17239A	
87	726-0278	PLAQUE D'ISOLATION	FINISH:NATUR ODER SCHWARZ	
88	738-0155	VIS EPAULEE	FINISH:MTD SPEC-100015	
89	738-0296	AXE EPAULE	FINISH:SPEC-100015	
90	736-0141	RONDELLE	FINISH:MTD SPEC-100016	
91	710-0604	VIS HEX.TT:5/16-18:0.62	FINISH:MTD SPEC-701-01006	
92	726-0279	PLAQUE D'ISOLATION	FINISH:NATUR ODER SCHWARZ	
94	723-0423	MARCHE PIED	Antirutschbelag	
94A	735-0254	TAPIS CAOUTCHOUC CENTRAL		

Position	Numéro de pièce	Appellation I	Appellation II	Remarque
95	725-1303	RESSORT DE SURETE SIÈGE	SI.-SCHALTER SITZ:SPEC-100015	
96	731-1228	TABLEAU DE BORD	731-1228 (mit Amp.M.+Lichts	avec ampermetre et contacteur lumière
96A	731-1502	TABLEAU DE BORD	731-1502 (ohne Amp.M.+Lichts	sans ampermetre et contacteur lumière
97	731-0063	TABLEAU DE CONTRÔLE		7-Style, 8- Style
97A	731-04184	TABLEAU DE BORD	OHNE AMPEREMETER	8-Style à partir du numéro de fabrication AI162L50011
97B	731-2432	TABLEAU DE BORD	400er RIDER/NACHARB.A.731-0063	9-Style
97C	731-0063*-U	TABLEAU DE BORD	UNIVERT-FRANCE/OHNE LICHTSCH.-	
98	17782	CLIP: STARTER DE TRACTION	FINISH:VERZINKT	
102	725-0925	AMPEREMETRE ANGULEUX	725-0925	
103	712-3007	ECROU HEX. 5/16-18 GR5	FINISH:MTD SPEC-100015	
104	710-1355	VIS HEX.TT:M5X.7:10.00:HEXFLG	HEXFLG WN 1321:SPEC-701-01006	
107	710-3015	VIS:1/4-20:.75:GR5:STD	FINISH:MTD SPEC-100015	
108	712-0271	ECROU 1/4-20"+ DISQUE DENTE	FINISH:MTD SPEC-100016 GR5	
111	723-0444	CEINTURE DE SECURITE BATTERIE	FINISH:SCHWARZ	
112	725-0689	BOUCHON BATTERIE	725-0689	
113	783-0297	ÜCRAN SIÈGE- COMMUTATEUR	783-0297-0637	
114	725-0157	COLLIER DE SERRAGE3/16X0.5X7.4	MATERIAL:NYLON-SCHWARZ	fsg

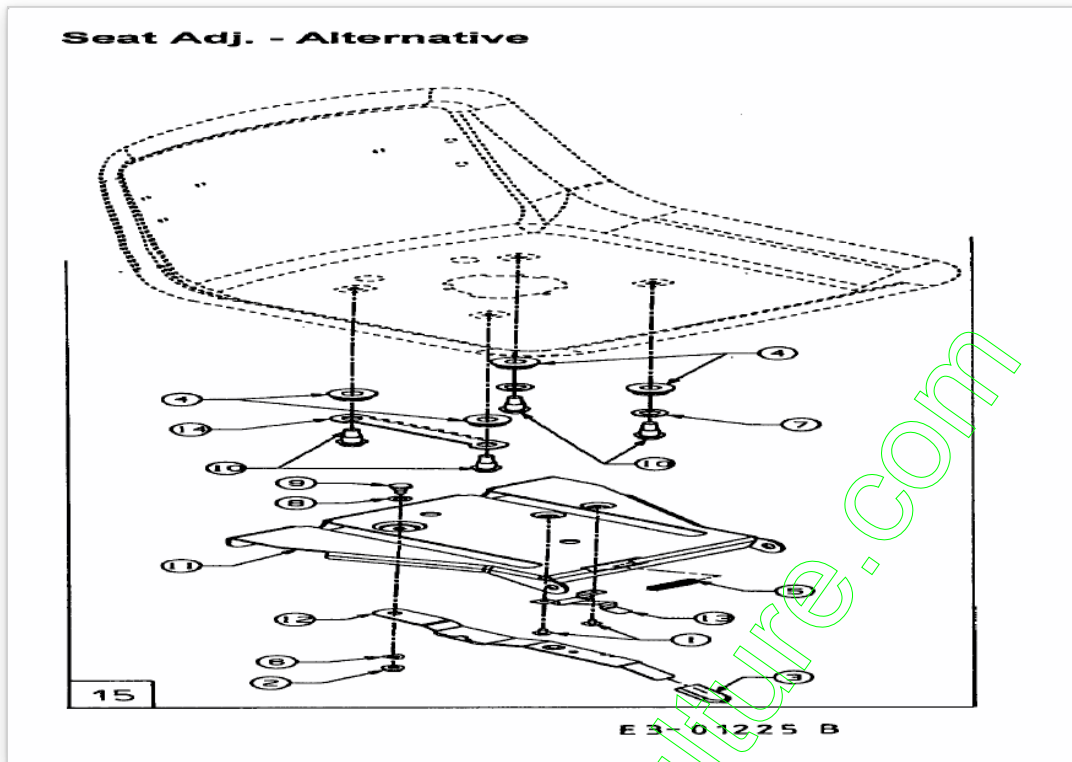

Position	Numéro de lapièce	#	Appellation I	Appellation II
1	710-1268	2	VIS HEX.:B#10-16:0.375	HXINDWSH:SP FINISH:701-01002
2	712-3027	1	ECROU HEXAGONAL 1/4-20:GRF	FINISH:MTD SPEC-100015
3	720-0309A	1	POIGNÜE PLASTIQUE	FINISH:SCHWARZ
4	731-1989	4	ENTRETOISE AJUSTEMENT SIEGE	731-1989
5	732-0499	1	RESSORT	FINISH:SPEC-100015
6	736-0175	1	RONDELLE GROWER: .265x.562x.025	FINISH:701-01001
7	736-0192	4	RONDELLE .531 X 93 X .090	FINISH:MTD SPEC-100015
8	736-0204	1	RONDELLE .344 X 62 X.03	FINISH:MTD SPEC-100015
9	738-0137A	1	VIS A EPAULE .340 X .285:1/4-2	FINISH:GM4435M CODE A
10	738-1007	4	VIS 50X.50/8-16	GRADE 5:FINISH SIEHE ZG:
11	783-0607A	1	SUPPORT SIEGE	
12	783-0609	1	LEVIER DE SIEGE	783-0609-0637
13	783-0611	1	ARRET AJUSTAGE DE SIEGE	FINISH:PHOS & OIL
14	783-0753	1	CREMAILLERE REGLAGE SIEGE	FINISH:SPEC-100015
15	813-06031	1	SELECTEUR SIEGE KIT	E-TEIL-SET

www.emc-motoculture.com

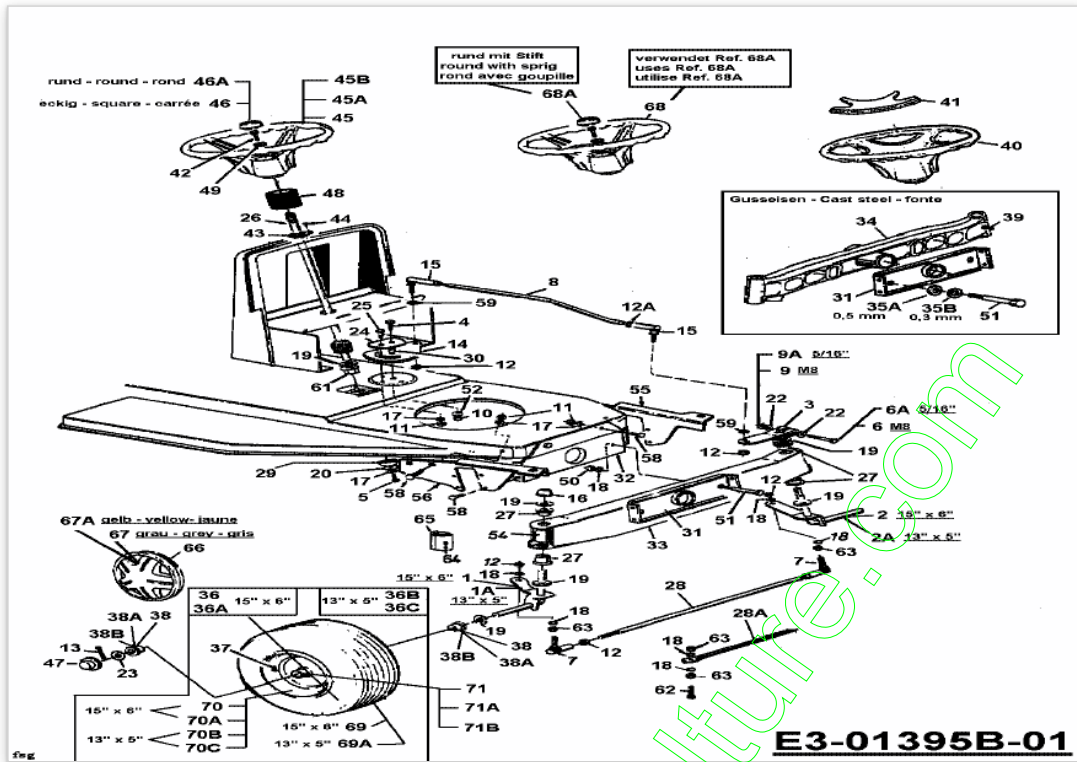

Position	Numéro de pièce	#	Appellation I	Appellation II	Remarque
1	17584A637	1	AXE AVANT DROIT	SCHWARZ GEPULVERT	seulement pour roues 15" x 6"
1A	683-0040A	1	AXE AVANT DROIT	3.41 X 4.05	seulement pour roues 13" x 5"
2	17585A637	1	AXE AVANT GAUCHE NOIR	SCHWARZ GEPULVERT	seulement pour roues 15" x 6"
2A	683-0041A	1	AXE AVANT GAUCHE	683-0041A/983-0041A SCHWARZ	seulement pour roues 13" x 5"
3	683-0055	1	LEVIER DIRECTION	683-0055/983-0055-0637	
4	710-1039		VIS	FINISH:MTD SPEC-100015	
5	710-0538		VIS HEX.:5/16-18:.625:GR.5:LOC	FINISH:701-01000	
6	710-1684		VIS A SIX PANS CREUX	MTD SPEC-100015 21.1441.78	
6A	710-0593		VIS	STD FINISH:701-01000	
7	723-3018	2	ROTULE DE DIRECTION 3/8-24	FINISH:	
8	711-1117A	1	TIGE DE DIRECTION		
9	712-0692		ECROU HEXAGONAL 24.1426.18	FINISH:SPEC-100015 24.1426.18	
9A	712-0411		ECROU HEXAGONAL	FINISH:MTD SPEC-100015	
10	712-0214		ECROU	FINISH:SPEC-100015	
11	712-0158		ECROU EX AF-43064	FINISH:MTD SPEC-100015	
12	712-0262		ECROU	FINISH:MTD SPEC-100015	
12A	712-0240		ECROU HEX.: 7/16-20:GR2	FINISH:MTD SPEC-100015	
13	714-0470		EPINGLE EX AF-43010	FINISH:SPEC-100015 470 32 32	
14	717-0622A		SEGMENT DE DIRECTION	717-0622A	
15	723-0448A	2	ROTULE DE DIRECTION 7/16-20	FINISH:MTD SPEC-100015	
16	726-0214		BOUCHON	FINISH:SCHWARZ	
17	736-0119		RONDELLE	FINISH:MTD SPEC-100016	
18	736-0169		BAGUE ÉLASTIQUE	FINISH:MTD SPEC-100016	
19	736-0366		RONDELLE 5/8 ID X 1.0 OD	FINISH:MTD SPEC-100015	
20	736-0343		RONDELLE .330 ID X 1.25 X .12	FINISH:MTD 701-100015	
22	736-3081		RONDELLE 320X.600X.060HT	FINISH:701-01001	
23	736-0285		RONDELLE .635 X 1.589 X .06	FINISH:MTD SPEC-100015	
24	17198A		PLAQUE	17198A	
25	738-0141		AXE		
26	738-0937	1	ARBRE DE DIRECTION	738-0937	
27	741-0659	4	BAGUE DE TRAVERSE AVANT	941-0659	
28	747-0753	1	KIT TRINGLE DIRECTION	E-TEIL-SET	ajustable
28A	747-0861	1	VOIR 747-0861-0637	747-0861-0637	non ajustable
29	750-0532		ENTRETOISE 980IDX1.250DX.0420		
30	750-0535		ENTRETOISE	FINISH:GEÖLT	
31	17548	1	SUPPORT	17548 SCHWARZ GEPULVERT	
32	17547	1	SUPPORT	17547	
33	683-0128A637	1	ESSIEU AVANT ACIER	SCHWARZ GEPULVERT	
34	719-0342B	1	TRAIN AVANT FONTE	FINISH:SIEHE ZG.	
35A	736-0769	x	RONDELLE	13X19X0.5 (24.6273.44) ST	
35B	736-0770	x	RONDELLE D'AJUSTAGE DIN 988	13X19X0.3 ST	

Position	Numéro de lapièce	#	Appellation I	Appellation II	Remarque
36	634-0087A	2	ROUE COMPL 15X6,0		
36A	634-0091	2	ROUE COMPL	15 X 6	
36B	634-0097	2	ROUE COMPL 13" x 15"	634-0097-0662	
36C	634-0099	2	ROUE COMPL 13X5-6 COUSSINET	MIT CARLISLE REIFEN FELGE GRAU	
37	734-0255	2	VALVE:PNEU	TR 412-P / 32.6mm / 934-0255	
38	741-0487A		PALIER DE BRIDE	741-0487A (BR.748-0184)	Roulement de plastique
38A	741-0569		ROULEMENT DE ROUE AVANT	741-0569	Roulement à billes
38C	741-0706		SUPPORT DOUILLE AVEC GRAISSEUR	MIT SCHMIERNIPPEL	Roulement de plastique avec graissage
39	737-3000	2	GRAISSEUR	GLEITMITTEL	
40	731-1869	1	VOLANT ;625 NOIR		
41	731-1904	1	CACHE VOLANT	731-1904	
42	710-0643		VIS HEX.: 5/16-18:1.00:GR5	FINISH:MTD SPEC-100015	
43	741-0501		PALIER DE BRIDE ARBRE DE DIREC	FINISH:KUNSTSTOFF SCHWARZ	
44	710-0837		VIS	FINISH:MTD SPEC-100016 TYPE 1	
45	731-1693		VOLANT 12" 3 RAYONS		seulement pour couvercle rond
45A	731-1687		VOLANT 3 RAYONS		seulement pour couvercle carré
45B	631-0027		VOLANT 13,25 4 RAYONS	631-0027	4 rayo
46	731-0220		COUVERCLE / VOLANT	731-0220	rond
46A	731-1459		COUVERCLE BOUCHON /VOLANT	731-1459	quarrée
47	731-0484A		ENJOLIVEUR DEVANT	KUNSTSTOFF SCHWARZ 931-0484A	
48	731-0954		SOUFFLET GOMMEUX	731-0954	
49	736-0242		RONDELLE CONIQUE.340X.872X.060	FINISH:MTD SPEC-100016	
50	712-0431		ECROU STOP 3/8-16:GRF	FINISH:MTD SPEC-100015	
51	738-0527		BOULON	738-0527	
52	736-0356		RONDELLE	FINISH:MTD STD 701-01001	
54	731-1649		PALIER	PVC SCHWARZ: 450/500	
55	783-0255B		SUSPENSION D'AXE GAUCHE	783-0255B-0637	
56	783-0256B		SUSPENSION D'AXE DROITE	SCHWARZ GEPULVERT	
58	710-0604		VIS HEX.TT:5/16-18:0.62	FINISH:MTD SPEC-701-01006	
59	736-0217		RONDELLE GROWER	FINISH:MTD SPEC-100016	
61	741-0225		BAGUE HEXAGONALE TEFLON 6 PANS	FINISH:KUNSTSTOFF SCHWARZ	
62	710-0459A		VIS HEX.: 3/8-24:1.50:GR5:SPEC	SPEC:FINISH MTD STD 701-01000	
63	712-0241		ECROU HEX.: 3/8-24:GR5	FINISH:MTD SPEC-100015	
64	737-0280		GRAISSEUR	737-0280 / 937-0280	
65	731-1291A		CARTER PLASTIQUE	MATERIAL:PP SCHWARZ:LT5	
66	727-0425A		CLIP ENJOLIVEUR		
67	734-1613A		ENJOLIVEUR 6" gris		
67A	734-1787A		ENJOLIVEUR 6" JAUNE VIF	734-1787A	
68	631-04028		VOLANT	FINISH SCHWARZ	

Position	Numéro de pièce	#	Appellation I	Appellation II	Remarque
68A	731-04039		CAPUCHON DE VOLANT SANS LOGO	FINISH:KUNSTSTOFF SCHWARZ	
69	734-1731		PNEU 15X600X6 DICO MULTI-TRAC	SQ SHOULDER:TURF SAVER	
69A	734-0298		PNEU 13*500*6	734-0298-0901/-0902 000.75.551	
70	634-0173		JANTE 6,0X4,5	634-0173-0662 E-TEIL-SET	seulement pour modèle avec roulement de plastique
70A	634-0090		JANTE	634-0090-0662	seulement pour modèle avec roulement à bille
70B	634-0096		JANTE	634-0096	seulement pour modèle avec roulement de plastique
70C	634-0098A		ZUSAMMENBAU:FELGE:KUGELLAGER:	6X3.87 GEBOHRT	seulement pour modèle avec roulement à bille
71	737-0211A		DOUILLE/GRAISSE	737-0211A	seulement pour modèle avec roulement de plastique
71A	737-0280		GRAISSEUR	737-0280 / 937-0280	seulement pour modèle avec roulement à bille
71B	737-0212		GRAISSEUR	737-0212	n`est pas utiliser dans 15" x 6" avec roulement à bille

www.emc-motoculture.com

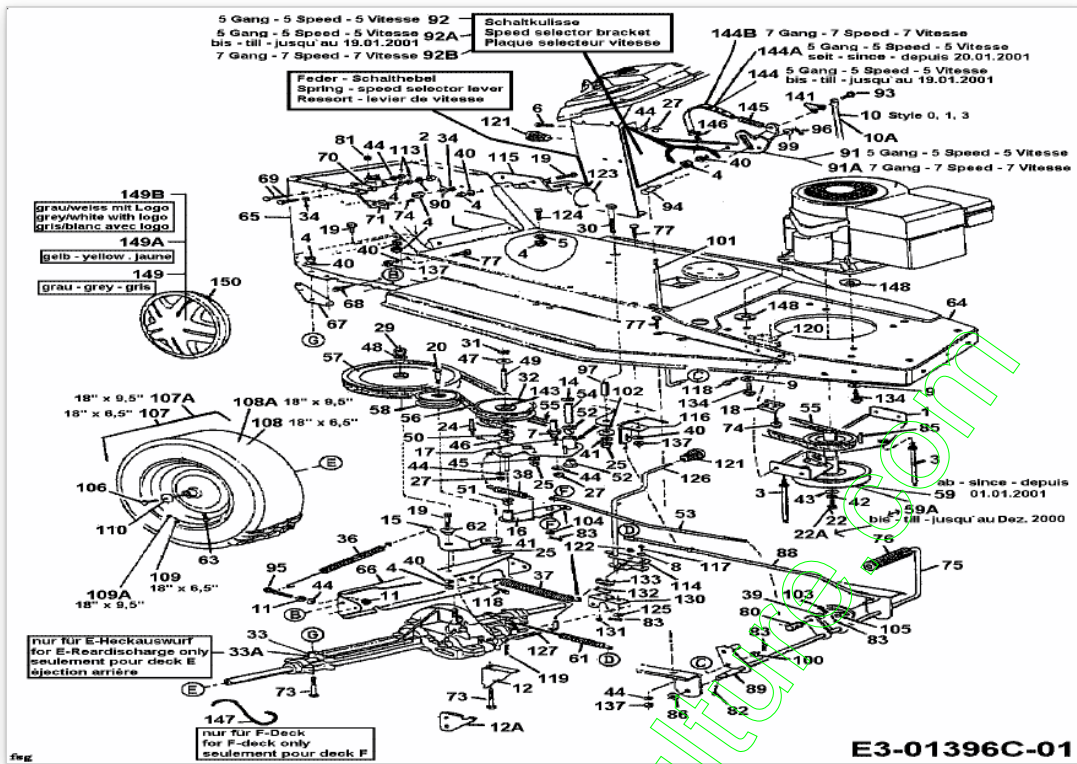

www.emc-motocult.fr

Position	Numéro de pièce	#	Appellation I	Appellation II	Remarque
1	783-0265A		PROTECTION COURROIE	783-0265A-0637	
2	712-0291		ECROU EX AF-43013	FINISH:ASTM F1941 FE/ZN 3AN	
3	711-1044		BOULON	5/16-18X4.6 /911-1044	
4	712-0267		ÛCROU HEXAGONAL	FINISH:MTD STD 701-01000	
5	736-0242		RONDELLE CONIQUE.340X.872X.060	FINISH:MTD SPEC-100016	
6	710-0286		VIS	FINISH:701-01000	
7	711-1000		GUIDE COURROIE 25 X 3.0	FINISH: 911-1000	
8	736-0270		RONDELLE GROWER	FINISH:MTD SPEC-100016	
9	736-3072		RONDELLE .38 x.93 x.110:HT	FINISH:701-01001	
10	749-0836A		TRINGLE	749-0836A-0637	
10A	749-0820		TRINGLE	749-0820	
11	712-0138		ECROU HEX. 1/4-28"	FINISH:MTD SPEC-100015	
12	17128A		SUPPORT EX.17128	17128A-0637	
12A	783-0138		SUPPORT DE FREIN	FINISH:schwarz gepulvert	
14	736-0235		RONDELLE 3/8X1.26 X .172	FINISH:MTD STD 701-01000	
15	17694		SUPPORT	FINISH:SIEHE ZG.	
16	16554A		SUPPORT VARIATEUR	16554A-0637 / 16554A-Z	
17	16676B		SUPPORT COMPLET	FINISH:PHOS&OIL OPT. LACKIERT	
18	17962		PLAQUE DE SUPP. P. COMMUTATEUR	FINISH:WIE GESTANZT	
19	710-3008		VIS 5/16-18:75:GR5:STD	SPEC-701-01006 or.SPEC-100015	
20	710-0151		VIS HEXAGONALE	FINISH:MTD SPEC-100015	
22	710-1002		VIS	FINISH:SPEC-100015	à partir du 01.01.2001
22A	710-0757		VIS	FINISH:701-01000 910-0757	jusqu`au décembre 2000
24	711-0768		GUIDE DE COURROIE	711-0768	
25	712-0241		ECROU HEX.: 3/8-24:GR5	FINISH:MTD SPEC-100015	
27	712-3006		ECROU HEXAGONAL	FINISH:SPEC-100015	
29	712-3035		ECROU HEXAGONAL	FINISH:STD 701-01000 912-3035	
30	710-0704		VIS HHCS:3/8-24:4.00:GR5:STD	FINISH: PHOS & OIL SIEHE ZG.	
31	716-0114		CIRCLIPS	FINISH:PHOSPHATIERT DIN 471	
32	717-0800A		POULIE VARIATEUR DE VITESSE	917-0800A NADELLAGER 741-0404	
33	618-0166D		TRANSMISSION	HINTERACHSE	
33A	618-0556		TRANSMISSION COMPLETE		seulement pour plateau de coupe E

Position	Numéro de lapièce	#	Appellation I	Appellation II	Remarque
					ejection arrière
34	736-0607		RONDELLE	FINISH:MTD SPEC-100016	
36	732-0384		RESSORT DE TRACTION	FINISH:SIEHE ZG.	
37	732-0459		RESSORT	FINISH:MTD STD 701-01000	
38	732-0568		RESSORT DE TRACTION	.50 OD X 2.54 LG	
39	736-0117		RONDELLE 3/8X.620X.033	FINISH:MTD SPEC-100015	
40	736-0119		RONDELLE	FINISH:MTD SPEC-100016	
41	736-0169		BAGUE ÜLASTIQUE	FINISH:MTD SPEC-100016	
42	736-0171		RONDELLE GROWER	FINISH:MTD SPEC-100016	
43	736-0322		RONDELLE .450 X 1.250 X .164	FINISH:SPEC-100016 936-0322	
44	736-0329		RONDELLE GROWER	FINISH:SPEC-100016 24.8195.16	
45	736-0331		RONDELLE CONIQUE	FINISH:MTD SPEC-100016	
46	736-0355		RONDELLE	FINISH:701-01001	
47	736-0414		RONDELLE TÜFLON	FINISH:WEISS: 936-0414	
48	736-0427		RONDELLE	FINISH:MTD STD 701-01001	
49	738-0569		AXE DE VARIATEUR	738-0569	
50	741-0405		ENTRETOISE	.56 ID x 1.25 OD x.06/941-0405	
51	741-0419		SUPPORT DE BRIDE / DOUILLE	741-0419	
52	741-0495		BAGUE	FINISH:KUNSTSTOFF WEISS	
53	747-0599B		TIGE DE RACCORDEMENT		
54	750-0703		ENTRETOISE 375IDX.625ODx1.54	750-0703	
55	754-0280A		COURROIE MOTEUR/VARIATEUR	POLY 754-0280A/ 954-0280A	
56	754-0281		COURROIE VARIATEUR/BOITE	754-0281/954-0281	
57	656-0003		POULIE	656-0003 DURCHM.20,4CM	
58	756-0643		POULIE TENDEUR PLASTIQUE	756-0643	
59	756-1182A		POULIE DOUBLE MOTEUR	3.56x5.56 DIA:701-01000/101642	à partir du 01.01.2001
59A	756-0551		POULIE DOUBLE MOTEUR	756-0551 / E-TEIL-SET	jusqu`au décembre 2000
61	732-0413		RESSORT DE TRACTION	FINISH:PHOS & OIL	
62	748-0234		RONDELLE EPAULEE	FINISH:ROSTPREVENTION	
63	734-0255		VALVE:PNEU	TR 412-P / 32.6mm / 934-0255	
64	17588C		CHASSIS AVANT	'97	
65	783-0180A		CHASSIS ARRIERE	400'96	

Position	Numéro de lapièce	#	Appellation I	Appellation II	Remarque
66	16654A		SUPPORT DE TRANSMISSION	16654A-0637	
67	16659		RENFORT	16659-0637	
68	710-0726		VIS 5/16- 12:0.750:HXINDWS	FINISH:MTD STD 701-01002	
69	710-0258		VIS	710-0258	
70	725-1426		RELAIS DE DEMARRAGE SOLENOID	725-1426 Mutter 712-0271	
71	725-0459		CONTACT VOIR 753-0685	725-0459	
72	736-0222		RONDELLE	FINISH:MTD SPEC-100016	
73	710-0176		VIS HEX.:5/16- 18:2.75:GR5:STD	(21.1441.82)FINISH:SPEC-100015	
74	710-0351		VIS	FINISH:MTD SPEC-100016	
75	17644A		PEDALE D EMBRAYAGE ET FREINS	SCHWEIßTEIL:LACKIERT	
76	735-0239		CAOUTCHOUC/PEDALE 4;0 LG	FINISH:SCHWARZ	
77	710-1012		VIS COTELEE: 5/16-24 x.87"LG	RD HD FINISH:PHOS & OIL	
80	711-0198		FUSEAU D'ÛCROU	FINISH:MTD SPEC 701-01000	
81	712-0271		ECROU 1/4-20"+ DISQUE DENTE	FINISH:MTD SPEC-100016 GR5	
82	714-0470		EPINGLE EX AF-43010	FINISH:SPEC-100015 470 32 32	
83	714-0507		GOUPILLE FENDUE 3/32 X .750	FINISH:MTD SPEC-100015	
85	714-0114		CLAVETTE	FINISH:PLAIN	
86	736-0256		RONDELLE .635ID X 930 OD X.03	736-0256	
88	747-0593		TIGE DE FREIN	747-0593	
89	750-0800		ENTRETOISE	.640IDX.76ODX1.21	
90	725-0976A		CABLE DE MASSE	725-0976A	
91	17457B		LEVIER DE VITESSE	FINISH:VERZINKT SIEHE ZG.	
91A	783-1153		LEVIER	FINISH:701-01000	seulement pour 7 vitesse
92	783-0994		PLAQUE SELECTEUR 5 VITESSES	TRANSMATIC E-DECK	
92A	16693B		PLAQUE SELECTEUR 5 VITESSE	E-TEIL-SET	jusqu`au 19.01.2001
92B	783-0993		PLAQUE	FINISH:783-0993-Z	
93	738-0138		AXE	738-0138	
94	711-0677		FUSEAU D'ÛCROU - EX 711-0611	FINISH:MTD SPEC-100015	
95	710-0428		VIS HEXAGONALE	FINISH:701-01000	
96	714-0104		GOUPILLE	FINISH:PHOS AND OIL	

Position	Numéro de pièce	#	Appellation I	Appellation II	Remarque
97	750-0703		ENTRETOISE 375IDX.625ODx1.54	750-0703	
99	736-0264		RONDELLE: .330 x.630 x.0635	FINISH:SPEC-100015 936-0264	
100	736-0463		RONDELLE	FINISH:MTD SPEC-100015	
101	747-0675A		TIGE FILETEE	747-0675A	
102	736-0133		RONDELLE .411X1.25X1.00	FINISH:MTD SPEC-100015	
103	714-0115		GOUPILLE FENDUE 1/8 x 1.0	FINISH:MTD SPEC-100015	
104	736-0275		RONDELLE	FINISH:MTD SPEC-100015	
105	736-0278		RONDELLE	FINISH:MTD SPEC-100016	
106	710-0627		VIS HEX. 5/16-24:.750 GR5:LOCK	FINISH:MTD SPEC-100015	
107	734-0592662	2	ROUE COMPLETE 18 6.5 GRISE	FELGE:OYSTER GRAY 788-0662	
107A	734-0817662	2	ROUE COMPL. 18X9.50-8 GRISE	FELGE:OYSTERGRAU 788-0662	
108	734-0294	2	PNEU 18*650 *8	SQ:SH:TS 734-0294-0901/902	
108A	734-0448	2	PNEU 18*950*8	TURF SAVER 734-0448-0901	
109	634-0069662	2	JANTE	OYSTER GRAU GEPULVERT	18" x 6,50"
109A	634-0070662	2	JANTE GRISE	OYSTER GRAY GEPULVERT	18" x 9,50"
110	736-0242		RONDELLE CONIQUE.340X.872X.060	FINISH:MTD SPEC-100016	
113	712-0298		ECROU HEXAGONAL AF- 43015	FINISH:MTD SPEC-100015	
114	17178A		PLAQUE D'AJUSTEMENT	17178A	
115	17839		SUPPORT	17839	
116	17597		SUPPORT DE TIGE DE FREIN	17597-Z	
117	710-3013		VIS HEXAGONALE	FINISH:MTD SPEC-100015	
118	710-0599		VIS A SIX PANS CREUX	FINISH:MTD SPEC-101617	
119	714-0149B		GOUPILLE FENDUE 1/2"	FINISH:MTD SPEC-701-01006	
120	725-1657A		SECURITE D'EMBRAYAGE	Sich.Mähwerk+Kuppl. GRAU	
121	720-0232		BOUTON DE LEVIER MANUEL	FINISH:KUNSTSTOFF SCHWARZ	
122	726-0231		CLIPS	726-0231	
123	732-0525		RESSORT DE RAPPEL LEVIER	FINISH:PRE-GALVANIZED	
124	710-0650		VIS HEX.:TT:5/16- 18:0.875	FINISH:MTD SPEC-100016 TYPE 1	
125	736-0226		RONDELLE	FINISH:MTD SPEC-100015	
126	747-0694A		LEVIER EX 747-0694	FINISH:747-0694A-Z	
127	747-0685		LEVIER DE RACCORD	747-0685	

Position	Numéro de lapièce	#	Appellation I	Appellation II	Remarque
130	718-0238		SUPPORT	718-0238-0637	
130A	17179		SUPPORT	17179	jusqu` au septembre 2002
131	710-0227		VIS	FINISH:MTD SPEC-100016 TYPE 1	
132	726-0320		PLAQUE D'ISOLATION	FINISH:NATUR ODER SCHWARZ	
133	725-1644		INTERRUPTEUR DE SÜCURITÜ	FINISH:MTD SPEC-100015	
134	710-0502A		VIS HEX. 3/8-16:1.250 LG.	SELBSTSCHN. SPEC / 701-01002	
135	710-0672		VIS HEX. 5/16- 24:1.25:GR5:STD	FINISH:MTD SPEC-100015	
137	712-0123		ÜCROU HEXAGONAL	FINISH:701-01000	
141	736-0141		RONDELLE	FINISH:MTD SPEC-100016	
143	741-0404	2	ROULEMENT A AIGUILLE VARIATEUR	741-0404/941-0404	
144	683-0239		BANDE INDICATRICE 5 VITESSES		jusqu` au 19.01.2001
144A	683-0332		BANDE INDICATRICE 5 VITESSES	TRANSMATIC	depuis 20.01.2001
144B	777-9586B		ORDRE CHANGEMENT 7 VITESSES		
145	732-0691		RESSORT	732-0691	seulement pour Style 0,1,3
146	747-0816		CROCHET IND VIS	747-0816	
147	732-0722		CROCHET DE RESSORT	732-0722	seulement pour plateau de coupe F
148	736-0702		RONDELLE	MTD-SPEC 100015 24.6486.22	
149	734-1615A		ENJOLIVEUR 8" GRIS	734-1615A	
149A	734-1788A		ENJOLIVEUR 8" JAUNE VIF	734-1788A	
149B	734-1784A		ENJOLIVEUR 8" BLANC		
150	727-0425A		CLIP ENJOLIVEUR		

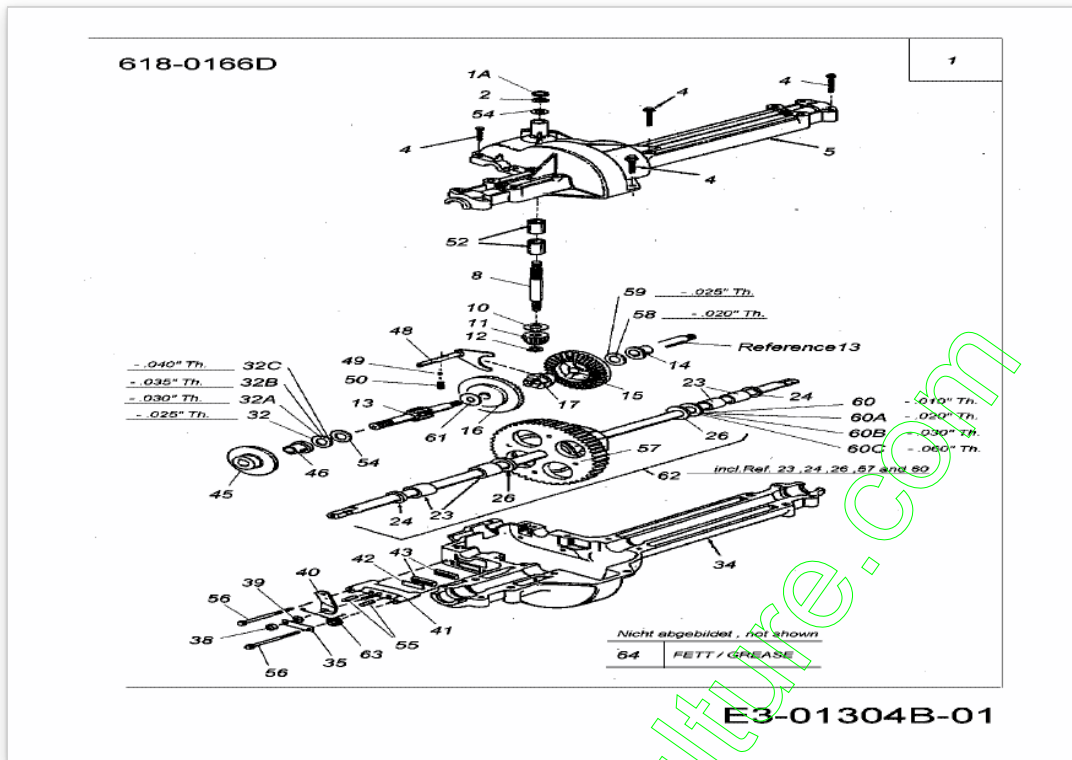

Position	Numéro de lapièce	#	Appellation I	Appellation II
1	618-0166D	1	TRANSMISSION	HINTERACHSE
1A	732-0614	1	CIRCLIPS	FINISH:ZINC PHOSPHATE
2	716-0231	1	CIRCLIPS	FINISH:SPEC-100016
4	710-1325	13	VIS HEXAGONALE	FINISH:SPEC-100016 TYPE 1
5	719-0367	1	MOITÜ DE CARTER SUPERIEUR	OBEN
8	711-1109	1	ARBRE D'ADMISSION	FINISH:SIEHE ZG.
10	736-0335	1	RONDELLE 1 5/8XA1.25"X.06	FINISH:SIEHE ZG.
11	717-1464	1	PIGNON CONIQUE 14 DENTS	FINISH:HITZEBEHANDELT
12	716-0108	1	CIRCLIPS 7/16"	FINISH:PHOSPATIERT 916-0108
13	711-1016	1	ARBRE D'ENTRAINEMENT FR.A G.	711-1016/911-1016
14	741-0336	1	BAGUE	FINISH:SIEHE ZG. 941-0336
15	717-1362	1	PIGNON CONIQUE 42 DENTS PT US	717-1362 / 917-1362 *
16	717-1363	1	PIGNON CONIQUE 42 DENTS GR US	717-1363/917-1363 *
17	718-0228	1	CRABOT	718-0228
23	741-0340	4	DOUILLE	ÖLIMRÄGNIERT EXXON 941-0340
24	721-0338	2	JOINT	.75 x 1.00 x .125:FINISH STD
26	736-0445	1	RONDELLE	FINISH:MTD SPEC-100016
32	736-0495	1	RONDELLE	FINISH:SIEHE ZG. 936-0495
32A	736-0773	1	RONDELLE	24.6273.68
32B	736-0494	1	RONDELLE	FINISH:MTD SPEC-100016
32C	736-0337	1	RONDELLE 5/8 IDX1.0 ODX.040	MTD STD 701-01001 936-0337
34	719-0313B	1	MOITIÜ INFÜRIEURE DE CARTER	UNTEN
35	718-0150	1	LANG. DE SUPP.: ANTI ROTATION	FINISH:SPEC-100015
38	712-0273	1	ECROU HEXAGONAL 5/16-24"	FINISH:MTD SPEC-100015
39	736-0371	1	RONDELLE 1.344XA .875"	FINISH:MTD SPEC-100016
40	717-0772B	1	LEVIER DE FREIN	FINISH:PHOSPHATE & OIL
41	761-0198A	1	APPUI DE FREIN	FINISH:NONE 961-0198A
42	717-0682	1	INSERT DE FREIN	FINISH:NONE 917-0682
43	717-0678	2	PLAQUETTE DE FREIN	FINISH:
45	761-0202	1	DISQUE DE FREIN	FINISH:ÖL UND FETTFREI
46	741-0337	1	BAGUE	941-0337
48	611-0011	1	FOURCHETTE	FINISH: 911-0011
49	741-0862	1	BILLE	FINISH: SIEHE ZG.
50	732-0863	1	RESSORT j PRESSION 225X.50"	FINISH: PHOS & OIL 932-0863
52	741-0335	2	ROULEMENT 1,5/8X1/2" LG	FINISH:SIEHE ZG. 941-0335
54	736-0349	1	RONDELLE 5/8 IDX10 OD X .020	FINISH:SIEHE ZG.
55	741-0343	2	GOUJON DE PRESSION 5/16"	FINISH:SIEHE ZG. 941-0343
56	710-1206	2	VIS HEX. TT:1/4-20:2.375	FINISH:MTD SPEC-100016 TYPE 1

Position	Numéro de lapièce	#	Appellation I	Appellation II
57	717-1364	1	PIGNON DIFFÜRENTIEL 58 DENTS	717-1364 / E-TEIL-SET
58	736-0349	1	RONDELLE 5/8 IDX10 OD X .020	FINISH:SIEHE ZG.
59	736-0495	1	RONDELLE	FINISH:SIEHE ZG. 936-0495
60	736-0492	1	RONDELLE 76X1.5X.010	FINISH:MTD SPEC-100016
60A	736-0493	1	RONDELLE 76X1.5X.020	FINISH:MTD SPEC-100016
60B	736-0351	1	RONDELLE .75x1.50"	FINISH:MTD SPEC-100016
60C	736-0445	1	RONDELLE	FINISH:MTD SPEC-100016
61	736-0519	1	RONDELLE	FINISH:WET TUMBLE 936-0519
62	618-04093A	1	DIFFERENTIEL COMPLET	918-04093A
63	732-0743	1	RESSORT	FINISH:ZINC PHOS&OIL 932-0743
64	001.51.050	1	GRAISSE 1 KG	DURAPLEX EP00

www.emc-motoculture.com

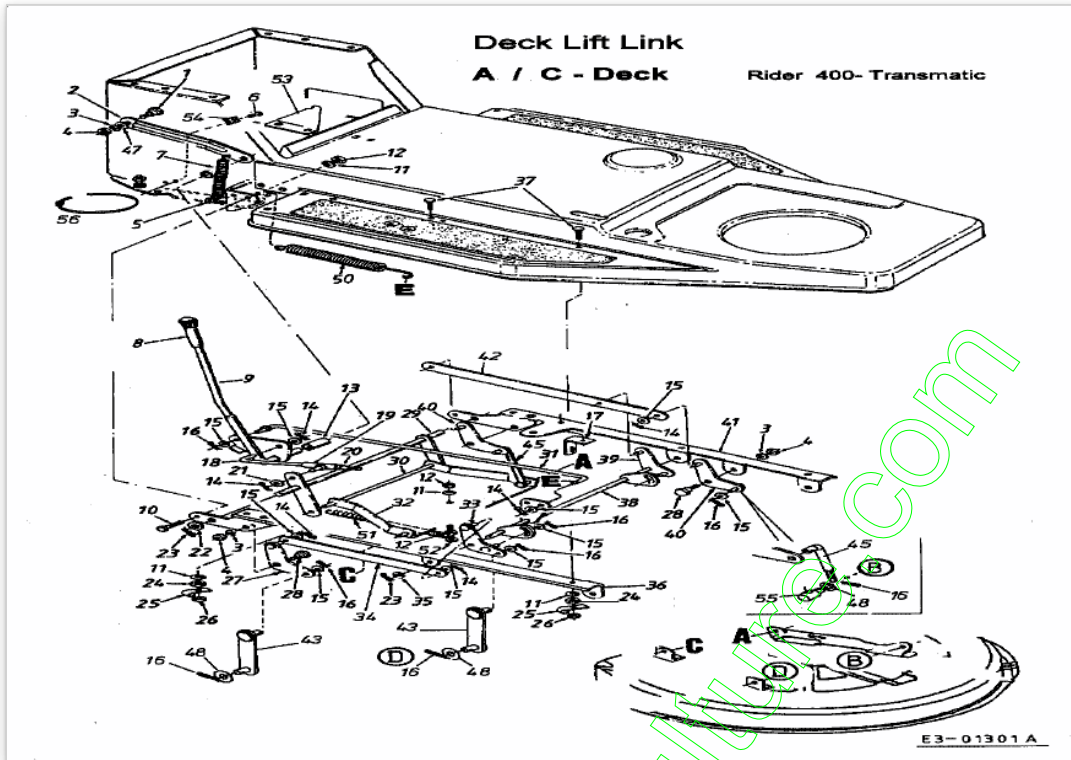

www.emc-motocultures.com

Position	Numéro de pièce	Appellation I	Appellation II	Remarque
1	738-0143	VIS EPAULEE	FINISH:MTD SPEC 100015 (EU)	
2	17580	SUPPORT	17580-0637	
3	736-0169	BAGUE ÜLASTIQUE	FINISH:MTD SPEC-100016	
4	712-0798	ECROU HEXAGONAL	912-0798	
5	710-0428	VIS HEXAGONALE	FINISH:701-01000	
6	710-0351	VIS	FINISH:MTD SPEC-100016	
7	732-0640	RESSORT LEVIER RELEVAGE	FINISH:PHOS & OIL	
8	631-0026	POIGNÜE	631-0026 RB 731-2509 in USA	
9	17591A	LEVIER	FINISH:17591A-Z VERKLIPPT	
10	710-0604	VIS HEX.TT:5/16-18:0.62	FINISH:MTD SPEC-701-01006	
11	736-0119	RONDELLE	FINISH:MTD SPEC-100016	
12	712-0267	ÜCROU HEXAGONAL	FINISH:MTD STD 701-01000	
13	750-0379	ENTRETOISE .647 IDX 780DX .85	750-0379	
14	714-0507	GOUPILLE FENDUE 3/32 X .750	FINISH:MTD SPEC-100015	
15	736-0185	RONDELLE 3/8.738X.063	FINISH:MTD SPEC-100015	
16	714-0104	GOUPILLE	FINISH:PHOS AND OIL	
17	17597	SUPPORT DE TIGE DE FREIN	17597-Z	
18	747-0746	TIGE FILETEE	FINISH:PHOS & OIL ODER ZINC	
19	16682P	DOUILLE DE GUIDAGE	16682P-0637	
20	712-0130	ECROU POLY STOP 3/8-16" GR 8	FINISH:MTD SPEC-100015	
21	736-0314	RONDELLE	FINISH:MTD SPEC-100016	
22	736-0116	RONDELLE	FINISH:MTD SPEC-100015	
23	714-0470	EPINGLE EX AF-43010	FINISH:SPEC-100015 470 32 32	
24	712-0123	ÜCROU HEXAGONAL	FINISH:701-01000	
25	726-0354	SUPPORT FUSEAU	FINISH:GLANZVERZINKT	
26	712-0237	ECROU EX.712-0305	FINISH:MTD SPEC-100015	
27	17555	VOIR 97555	17555-0637	
28	738-0281	VIS ÜPAULE:.625 x.17:3/8-16	FINISH:SPEC-100015 938-0281	
29	17574	ARBRE	17574-0637 SCHWEIßTEIL	
30	738-0667	AXE	E-TEIL-SET	
31	747-0745	LEVIER	17.8 LG FINISH:SIEHE ZG	
32	17573A	PLAQUE STABILISATEUR PLATEAU	17573A-0637	
33	17554	SUPPORT	17554-0637	
34	17563	FERRURE D	17563-0637	
35	736-0336	RONDELLE 5/8X1.00X.030	FINISH:MTD SPEC-100016	
36	17582	SUPPORT	17582-0637	
37	710-1012	VIS COTELEE: 5/16-24 x.87"LG	RD HD FINISH:PHOS & OIL	
38	683-0232	ARBRE CPL.	SCHWEISSSTEIL:683-0232-0637	

Position	Numéro de lapièce	Appellation I	Appellation II	Remarque
39	17557	SUPPORT GAUCHE	17557-0637	
40	17556	SUPPORT		
41	17581	SUPPORT	17581-0637	
42	17562	FERRURE G	17562-0637	
43	683-0111	ECLISSE DE JONCTION COMPL	.88 X3.31 LG	
45	747-0634	TIGE LEVIER 3/8 X 3,62		
47	736-0192	RONDELLE .531 X 93 X .090	FINISH:MTD SPEC-100015	
48	736-0185	RONDELLE 3/8.738X.063	FINISH:MTD SPEC-100015	
49	736-0101	RONDELLE	FINISH:MTD SPEC-100015	
50	732-0638	RESSORT	FINISH:PHOS & OIL 32cm	
51	732-0603	RESSORT	FINISH:PHOS & OIL	
52	710-3038	VIS HHCS:5/16- 18:.875:GR5:STD	FINISH:701-01000	
53	783-0138	SUPPORT DE FREIN	FINISH:schwarz gepulvert	
54	17962	PLAQUE DE SUPP. P. COMMUTATEUR	FINISH:WIE GESTANZT	
55	711-3397	CHEVILLE ,375 DIAX 31L	FINISH:ZINC SIEHE ZG.	
56	725-0157	COLLIER DE SERRAGE3/16X0.5X7.4	MATERIAL:NYLON-SCHWARZ	fsg

www.emc-motoculture.com

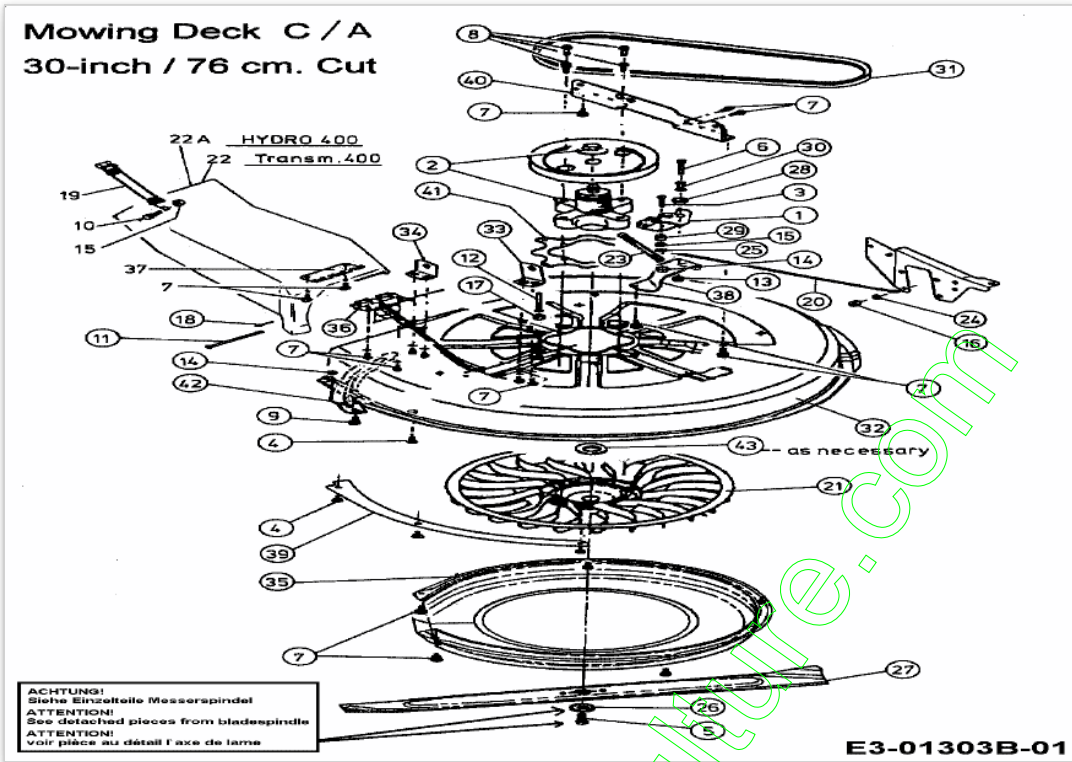

Position	Numéro de lapièce	#	Appellation I	Appellation II	Remarque
1	17116	1	FREIN A LAMES	17116/97116	
2	618-0139A	1	PALIER COMPLET 76CM ETOILEE	618-0139A	
3	710-0106	1	VIS HEX. 1/4- 20:1.25:GR5:SPEC	FINISH:MTD SPEC-100015	
4	710-1687	5	VIS A TETE PLATE	FINISH:Zn5glcB 22.3419.12	
5	710-1382	1	VIS HEX. M10X1X60LG. DIN 960	10.9 "SCHWARZ"	
6	710-3180	1	VIS HEX. 5/16- 18:1.75:GR5:STD	FINISH:SPEC-100015	
7	710-0599	16	VIS A SIX PANS CREUX	FINISH:MTD SPEC-101617	
8	710-0602	4	VIS	FINISH:MTD SPEC-100016 TYPE 1	
9	710-1759	2	VIS	MTD SPEC-100015 (000.02.242)	
10	710-3015	1	VIS:1/4- 20:.75:GR5:STD	FINISH:MTD SPEC-100015	
11	711-1054	1	BOULON ,250 X 4,42	GR2:FINISH:MTD SPEC-100015	
12	711-1065	1	AXE	FINISH:PHOS & OIL SIEHE ZG.	
13	712-0265	1	ECROU	FINISH:701-01001	
14	712-0691	1	ECROU HEXAGONAL	MTD SPEC-100015 24.1426.14	
15	712-3006	1	ECROU HEXAGONAL	FINISH:SPEC-100015	
16	712-3010	1	ECROU HEX. 5/16- 18:GR5	FINISH:MTD SPEC-100015	
17	712-3046	1	ECROU	FINISH:MTD SPEC-100015	
18	714-0507	1	GOUPILLE FENDUE 3/32 X .750	FINISH:MTD SPEC-100015	
19	723-0383	1	SANGLE POUR GOULOTTE D'EJECTI	FINISH:	
20	727-0470	1	CABLE DE FREIN DE LAME	16.47 LG	
21	731-1583	1	TURBINE DE VENTILATION	21 1000 000 820 FARBE: SCHWARZ	
22	731-1605C	1	CANAL D'ÜJECTION		seulement pour Transmatik
22A	731-2235	1	CANAL D'ÜJECTION		seulement pour Hydrostat
23	732-0604	1	RESSORT	FINISH:PHOS & OIL	
24	736-0204	1	RONDELLE .344 X 62 X.03	FINISH:MTD SPEC-100015	
25	736-0342	1	RONDELLE PLATE .283 x.75 x.030	FINISH:MTD STD 701-01000	
26	736-0684	1	RONDELLE	VERGÜTET-BLANK-GEÖLT	
27	742-0609C	1	LAME COUPE 76CM AVEC TURBINE		
28	748-0234	1	RONDELLE EPAULEE	FINISH:ROSTPREVENTION	

Position	Numéro de pièce	#	Appellation I	Appellation II	Remarque
29	750-0555	1	ENTRETOISE 254 IDX 50 OD x 3	750-0555	
30	750-0755	1	ENTRETOISE 330IDX.625ODX.915	750-0755	
31	754-0445	1	COURROIE DE LAME COUPE 76CM	754-0445 / 954-0445	
32	783-0247B	1	CARTER TONDEUSE	783-0247B-0637-0665	
33	783-0248	1	SUPPORT PLATEAU	FINISH:LACKIERT	
34	783-0249	1	SUPPORT PLATEAU	FINISH:LACKIERT	
35	783-0289	1	COUVERTURE SOUFFLANTE	F564.000.00 FINISH:LACKIERT	
36	783-0291	1	SUPPORT CONDUIT EJECTION	FINISH:BLAU CHROMATIERT	
37	783-0292	1	SUPPORT CONDUIT EJECTION	FINISH:GELBVERZINKT	
38	783-0295	1	SUPPORT	783-0295-0637	
39	783-0301	1	PLATEAU REINFORCE	783-0301-0637 783-0301*	
40	783-0304B	1	SUPPORT PLATEAU TONDEUSE	FINISH:SCHWARZ GEPULVERT	
41	783-0571	1	RENFORT	SCHWARZ GEPULVERT 783-0571*	
42	683-0215	1	ENTRETOISE COMPL. PIECE SOUDE	A.u.C DECK / 400er RIDER/0637	
43	736-0693	X	RONDELLE	28X40X0.3 24.6271.51 ST	
44	813-04198	1	PLATEAU COMPL 30"	TRANSMATIC	

www.emc-motocultivore.com

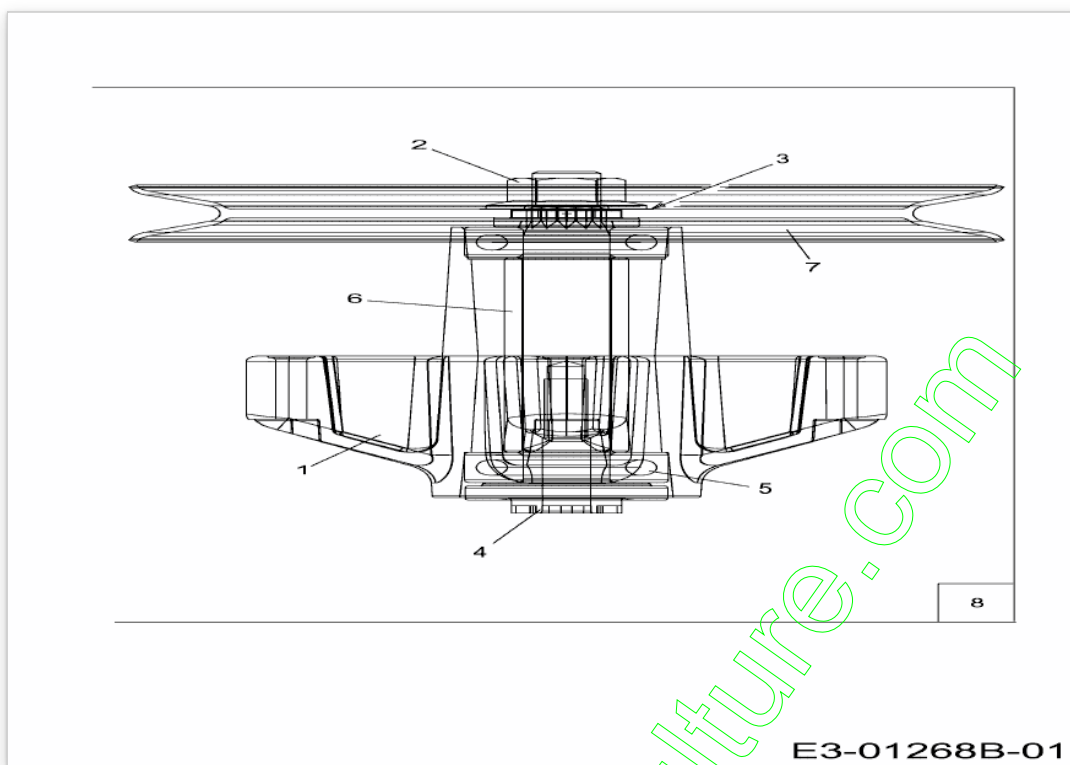

www.emc-motoculture.com

Position	Numéro de lapièce	#	Appellation I	Appellation II
1	619-0016	1	CORPS DE PALIER DE LAME	FINISH:NONE
2	712-0417A	1	ÜCROU HEX. AV. FLANC: 5/8-18	FINISH:MTD STD 701-01000
3	736-0693	1	RONDELLE	28X40X0.3 24.6271.51 ST
4	738-1043	1	AXE DE PALIER DE LAME	FINISH:EINGEÖLT
5	741-0919	2	ROULEMENT ; BILLES	FINISH:SIEHE SPEC.
6	750-0990	1	ENTRETOISE D'ECARTEMENT	FINISH:EINGEÖLT
7	756-0623	1	POULIE DE COURROIE TRAPÜZOID.	FINISH:MTD SPEC-100015
8	618-0139B	1	PALIER LAME COMPLET COUPE 76CM	KEILRIEMENSCHIEBE 918-0139B

www.emc-motoculture.com

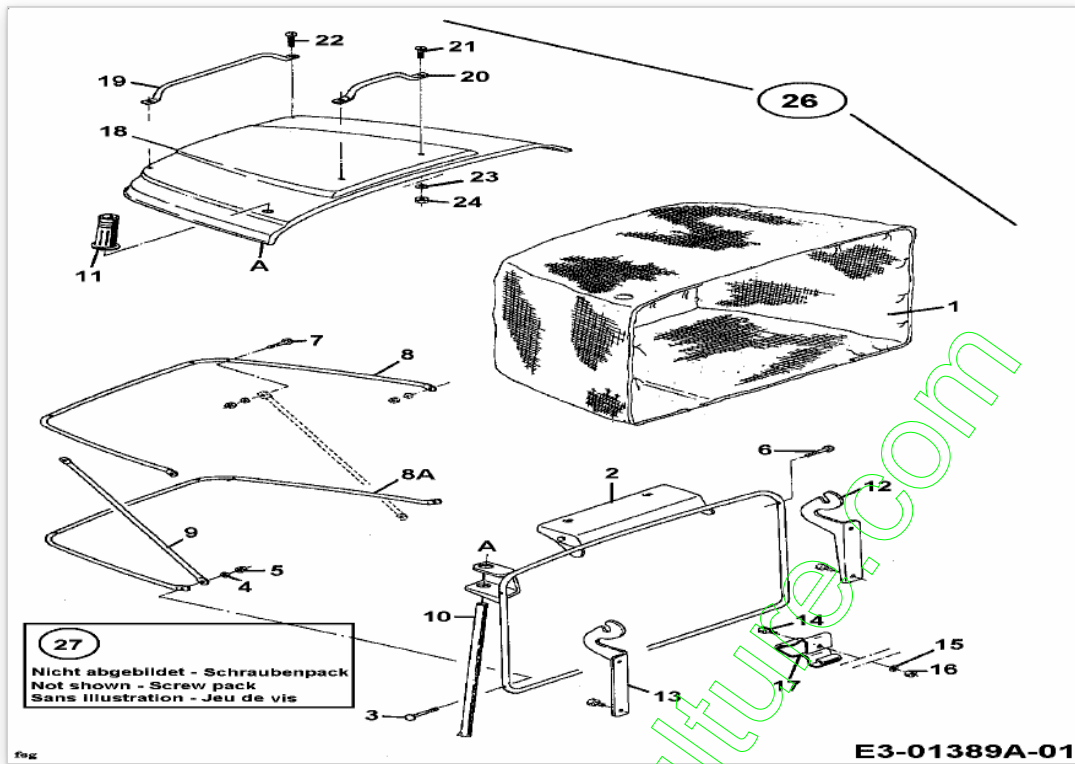

www.emc-motocultures.com

Position	Numéro de lapièce	#	Appellation I	Appellation II
1	664-0125A	1	TISSU BAC DE RAMASSAGE	SCHWARZ
2	683-0171B	1	CADRE BAC HA4145	SCHWARZ RAL 9005
3	710-1612	2	VIS A TETE PLATE:M5x30 DIN 603	FINISH:Zn5glcB 22.3419.03
4	736-0602	6	RONDELLE	FINISH:SPEC-100016 24.6481.12
5	712-0675	6	ECROU	FINISH:Zn5glcB 24.1426.12
6	710-1612	2	VIS A TETE PLATE:M5x30 DIN 603	FINISH:Zn5glcB 22.3419.03
7	710-1612	2	VIS A TETE PLATE:M5x30 DIN 603	FINISH:Zn5glcB 22.3419.03
8	749-1009	1	ARMATURE SUP SERIE 400A	FINISH: 032.80.011
8A	749-1010	1	ARMATURE INF SERIE 400A	FINISH: 032.80.014
9	749-1011	2	TRINGLE DE BAC SERIE 400A	032.80.012
10	749-1012	1	LEVIER DE RELEVAGE DECK A	032.80.013
11	720-0301	1	POIGNEE	MAGURA 240.1-10.22 000.37.552
12	783-0581	1	SUPPORT GAUCHE / SAC/HERBES	032.80.001
13	783-0582	1	SUPPORT DROIT / SAC/ HERBES	SCHWARZ RAL 9005 032.80.002
14	710-0258	2	VIS	710-0258
15	736-0329	2	RONDELLE GROWER	FINISH:SPEC-100016 24.8195.16
16	712-0287	2	ECROU HEXAGONAL 1/4-20:GR2	FINISH:701-01000 / 912-0287
17	732-0838	2	RESSORT BAC / HERBES	
18	783-0583	1	CAPOT DE BAC	783-0583-0638/0499/0665/0650
19	749-1013	1	POIGNEE LONGUE	MTD-SCHWARZ 032.80.004
20	749-1014	1	ÛTRIER COURT	SCHWARZ RAL 9005 032.80.005
21	710-1612	2	VIS A TETE PLATE:M5x30 DIN 603	FINISH:Zn5glcB 22.3419.03
22	710-1612	2	VIS A TETE PLATE:M5x30 DIN 603	FINISH:Zn5glcB 22.3419.03
23	736-0602	4	RONDELLE	FINISH:SPEC-100016 24.6481.12
24	712-0675	4	ECROU	FINISH:Zn5glcB 24.1426.12
26	813-04232	1	BAC AVEC CADRE	813-04232-638
27	753-0725	1	SACHET VISSERIES*** BAC A ***	400 A DECK MO.HARDTOP E-T-SET

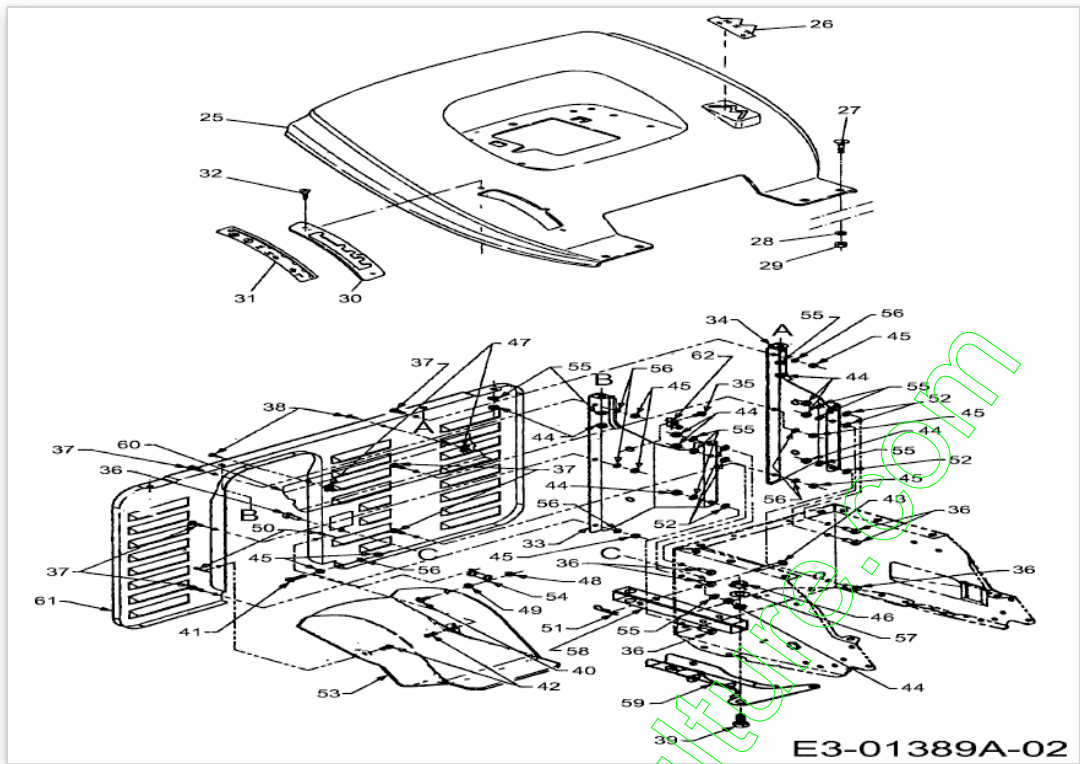

www.emc-motocult.com

Position	Numéro de lapièce	#	Appellation I	Appellation II
25	783-0584	1	SIEGE (CUVE)	032.46.008
26	777-0971	1	AUTOCOLLANT	F N R
27	710-0134	4	VIS j T#TE PLATE	FINISH:MTD SPEC-100015
28	736-0329	4	RONDELLE GROWER	FINISH:SPEC-100016 24.8195.16
29	712-0287	4	ECROU HEXAGONAL 1/4-20:GR2	FINISH:701-01000 / 912-0287
30	783-0384	1	PLAQUE D'ÜPAISSEUR DE COUPURE	VERZINKT
31	777-3361	1	AUTOCOLLANT RELEVAGE DECK	
32	710-1017	3	VIS	FINISH:MTD SPEC-100016
33	683-0106A	1	KONSOLE VST:HECKPLATTE RECHTS	SCHWEISSTEIL:FINISH LACKIERT
34	683-0105	1	CONSOLE PR PLAQUE ARR GAUCHE	SCHWARZ GEPULVERT
35	710-0599	1	VIS A SIX PANS CREUX	FINISH:MTD SPEC-101617
36	710-0118	6	VIS	FINISH:PHOS & OIL
37	710-0258	4	VIS	710-0258
38	710-0351	2	VIS	FINISH:MTD SPEC-100016
39	710-0493	1	VIS HEXAGONALE	FINISH:PHOS & OIL 710-3131
40	710-0134	1	VIS j T#TE PLATE	FINISH:MTD SPEC-100015
41	710-0597	1	VIS 1/4-20:1.00/GR5/SPEC	FINISH:701-100015
42	711-0701	2	GOUJON	FINISH:MTD SPEC-100015
43	711-0679	1	BOLT .375 X 1.88"	FINISH:PHOS & OIL
44	712-3010	10	ECROU HEX. 5/16-18:GR5	FINISH:MTD SPEC-100015
45	712-3006	4	ECROU HEXAGONAL	FINISH:SPEC-100015
46	712-0206	1	ECROU HEX. 1/2-13:GR.5	FINISH:MTD SPEC-100015
47	712-0147	2	ECROU 10-24 U-TYPE	FINISH:PLAIN
48	712-0291	1	ECROU EX AF-43013	FINISH:ASTM F1941 FE/ZN 3AN
49	712-0271	1	ECROU 1/4-20"+ DISQUE DENTE	FINISH:MTD SPEC-100016 GR5
50	714-0507	2	GOUPILLE FENDUE 3/32 X .750	FINISH:MTD SPEC-100015
51	714-0147	1	GOUPILLE j RESSORT:.125 X 1.75	FINISH:MTD SPEC-701-01006
52	726-0201	6	RONDELLE .3125 ID	MECHANISCH VERZINKT:SIEHE ZG.
53	731-1779	1	DEFLECTEUR COMPL.	
54	732-0755	1	RESSORT .595 x 2.105 LG	FINISH: PHOS & OIL
55	736-0119	11	RONDELLE	FINISH:MTD SPEC-100016
56	736-0329	6	RONDELLE GROWER	FINISH:SPEC-100016 24.8195.16
57	736-0253	1	RONDELLE	FINISH:MTD SPEC-100016
58	749-0966	1	TUBE DISPOSITIF D'ATTELAGE 400	749-0966-0637
59	783-0286	1	SUPPORT ATTACHE REMORQUE	783-0286-0637

Position	Numéro de lapièce	#	Appellation I	Appellation II
60	783-0308	1	DÜFLECTEUR	
61	783-0278	1	PLAQUE ARRIERE	FINISH:LACKIERT
62	16606	1	ÜTRIER D'ACCROCHAGE	FINISH:BLAU CHROMATIERT *

www.emc-motoculture.com

Rider Models 400

Engine B&S 28T707-1154-E1

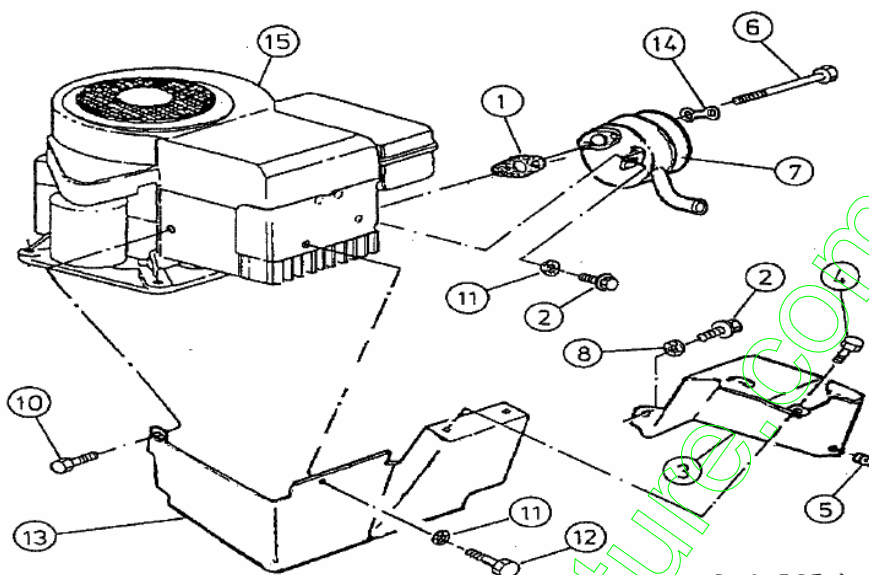

E3-01305 A

www.emc-motocultures.com

Position	Numéro de pièce	#	Appellation I	Appellation II	Remarque
1	721-0208	1	JOINT ECHAP B/S MONO CYLINDRE	FINISH:B&S #272293	
2	710-0599	2	VIS A SIX PANS CREUX	FINISH:MTD SPEC-101617	
3	683-0042A	1	AUTOCOLLANT PROTECTION	683-0042A-0637	
4	710-1268	1	VIS HEX.:B#10-16:0.375	HXINDWSH:SP FINISH:701-01002	
5	712-0147	1	ECROU 10-24 U-TYPE	FINISH:PLAIN	
6	738-0636	2	AXE	7/16ODx3.56x5/16	
7	751-0465A	1	ECHAPPEMENT	5":B&S	
8	736-0175	2	RONDELLE GROWER:.265x.562x.025	FINISH:701-01001	
10	710-0323	1	VIS	FINISH:701-01000	
11	736-0175	1	RONDELLE GROWER:.265x.562x.025	FINISH:701-01001	
12	710-0599	1	VIS A SIX PANS CREUX	FINISH:MTD SPEC-101617	
13	16936	1	PROTECTION CHALEUR AVANT	16936	
14	032.15.001	1	SICHERUNGSBLECH IM LIEFERUM	FANG AUSPUFF 751-0465A ENTHALT	seulement avec Ref. 7
15	752B1154E1	1	MOTEUR B&S 13,0CH I/C DL12	28T707-1154-E1	

www.emc-motoculture.com

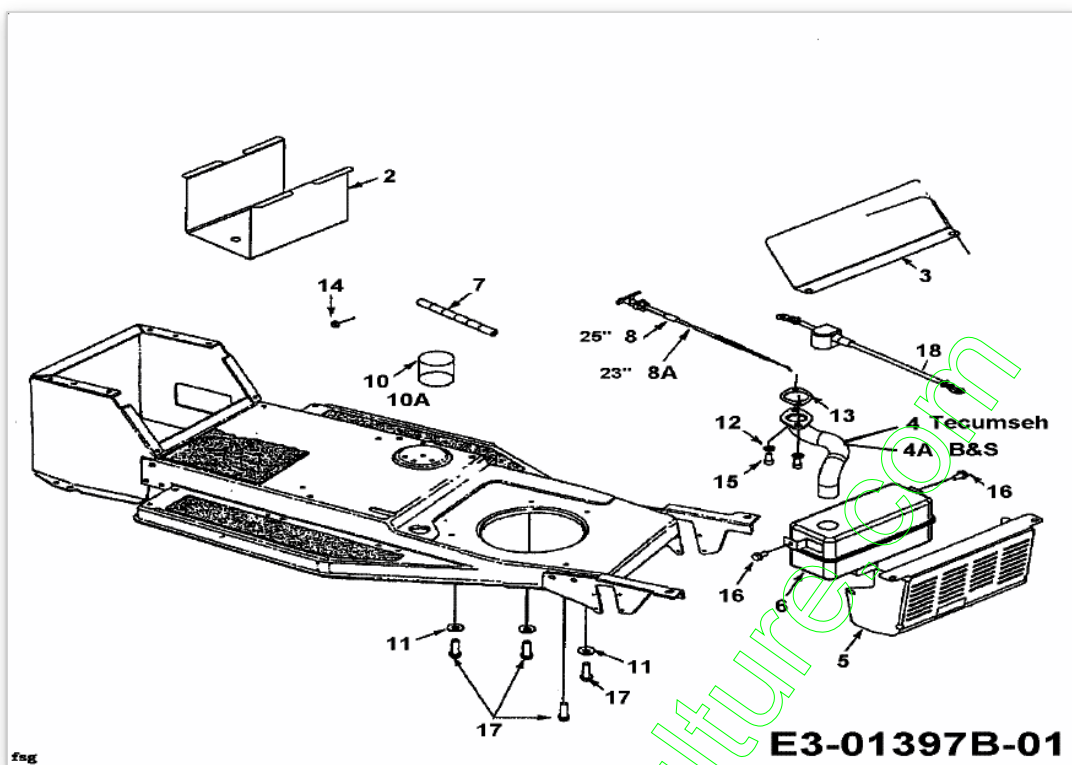

Position	Numéro de pièce	#	Appellation I	Appellation II	Remarque
2	783-0349	1	BOÏTIER DE BATTERIE	FINISH:LACKIERT SCHWARZ *	
3	751-0642	1	PROTECTION CHALEUR	751-0642	
4	751-0640	1	COLLECTEUR	751-0640	pour moteurs Tecumseh
4A	751-0628	1	TUYAU D'ÛCHAPPEMENT B&S OHV400	751-0628	Moteurs à essence Briggs&Stratton
5	751-0631A637	1	PROTECTION DE CHALEUR	SCHWARZ GEPULVERT	
6	751-0627	1	ÛCHAPPEMENT OHV 400	751-0627	
7	751-0535-MET	1	TUYAU D'ESSENCE (PAR METRE)	Beschaf.751-0535(Acht.inchx50)	
8	746-3026	1	CABLE 25,0 LG	746-3026	
8A	746-0616A	1	CABLE STARTER 58.4CM	746-0616A	
10	000.40.520	1	HUILE	(OEM-737-0295=1.4L-0208=0.6L)	
10A	OEM737-0295B	1	HUILE MOTEUR SAE30 1.4 Litres	HD 30 (WESTEUROPA)	
11	736-3072	3	RONDELLE .38 x.93 x.110:HT	FINISH:701-01001	
12	736-0119	2	RONDELLE	FINISH:MTD SPEC-100016	
13	721-0208	1	JOINT ECHAP B/S MONO CYLINDRE	FINISH:B&S #272293	
14	712-0271	1	ECROU 1/4-20" + DISQUE DENTE	FINISH:MTD SPEC-100016 GR5	
15	710-1314	2	VIS 5/16-18:625	710-1314	
16	710-0604A	2	VIS 5/16-18:0.625	FINISH:MTD SPEC-100016 TYPE 1	
17	710-0502A	4	VIS HEX. 3/8-16:1/250 LG.	SELBSTSCHN. SPEC / 701-01002	
18	629-0705	1	CABLE BATTERIE ROUGE 356MM	GUMMISCHUTZKAPPE GROSS ROT	

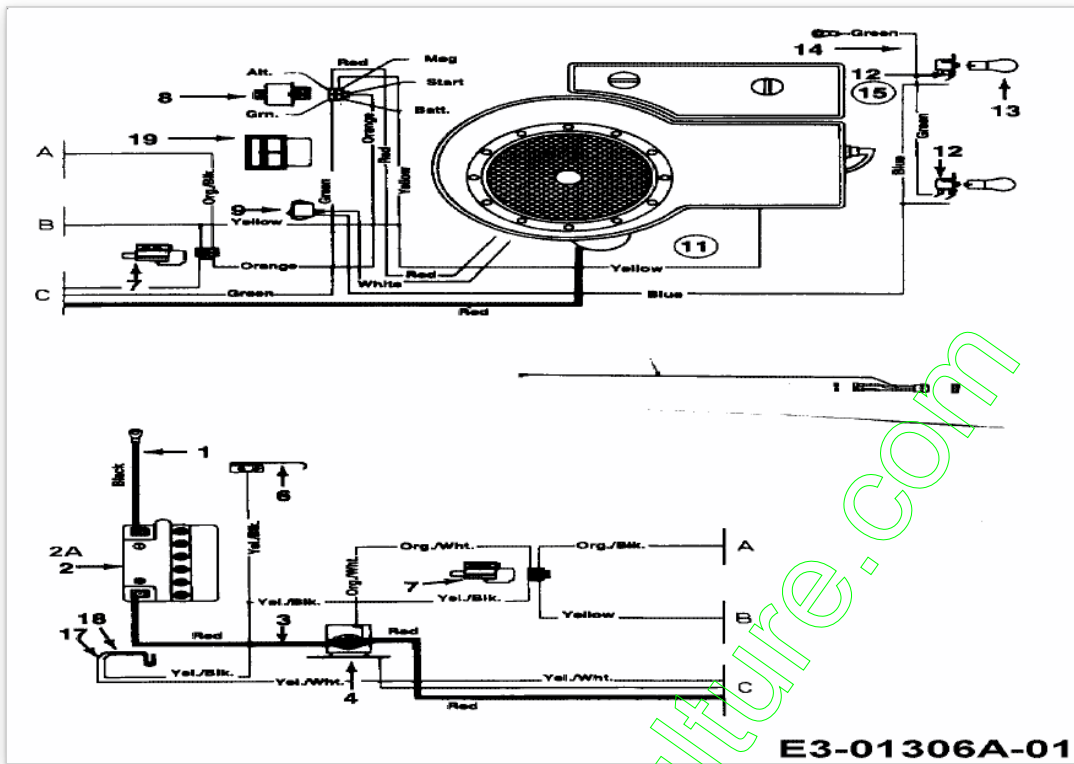

www.emc-motoculture.com

Position	Numéro de pièce	Appellation I	Appellation II	Remarque
1	629-0702	CABLE DE MASSE	8 X 13.0 LG SCHWARZ	
2	725-1707	BATTERIE		
2A	725-1635	BATTERIE 12V /20AH	C50N18L-A-CX	seulement pour machine avec plateau de coupe éjection arrière
3	629-0705	CABLE BATTERIE ROUGE 356MM	GUMMISCHUTZKAPPE GROSS ROT	
4	725-1426	RELAIS DE DEMARRAGE SOLENOID	725-1426 Mutter 712-0271	
6	725-1644	INTERRUPTEUR DE SÛCURITÛ	FINISH:MTD SPEC-100015	
7	725-1657A	SECURITE D'EMBRAYAGE	Sich.Mähwerk+Kuppl. GRAU	
8	725-0267	CONTACTEUR A CLE 5 FICHES	B.6PIN ERS.629-0234) 925-0267	
9	725-0634	COMMUTATEUR	FINISH: SCHWARZ	
11	629-0195A	FAISEAU COMPL	629-0195A	
12	725-1651	PORTE AMPOULE	925-1651	
13	725-0963	AMPOULE ELECTRIQUE	FINISH:	
14	629-0742	CABLE	#18 X 21.0 LG GRUEN	
15	629-0103	TUBE POUR INTERRUPTEUR PHARE	629-0103	
17	725-1303	RESSORT DE SURETE SIËGE	SI.-SCHALTER SITZ:SPEC-100015	
18	725-1439	RESSORT SURETE DE SIEGE	SI.-SCHALTER SITZ:SPEC-100015	
19	725-0925	AMPEREMETRE ANGULEUX	725-0925	

www.emc-motoculture.com

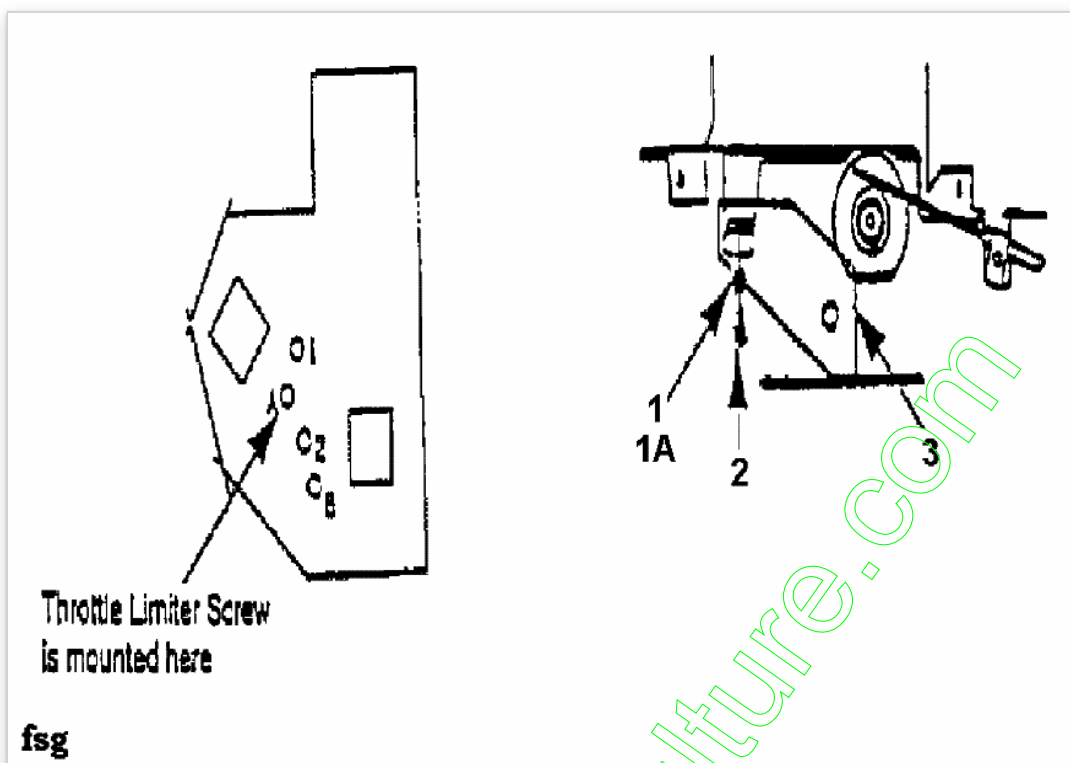

Position	Numéro de lapièce	Appellation I	Appellation II
1	736-0400	RONDELLE PLATE .194x.62x.063	FINISH:MTD SPEC-100015
1A	710-0456	VIS	FINISH:701-01002
2	710-0899A	VIS HEXAGONALE	FINISH:MTD SPEC-100016
3	17483	SUPPORT	17483

www.emc-motoculture.com

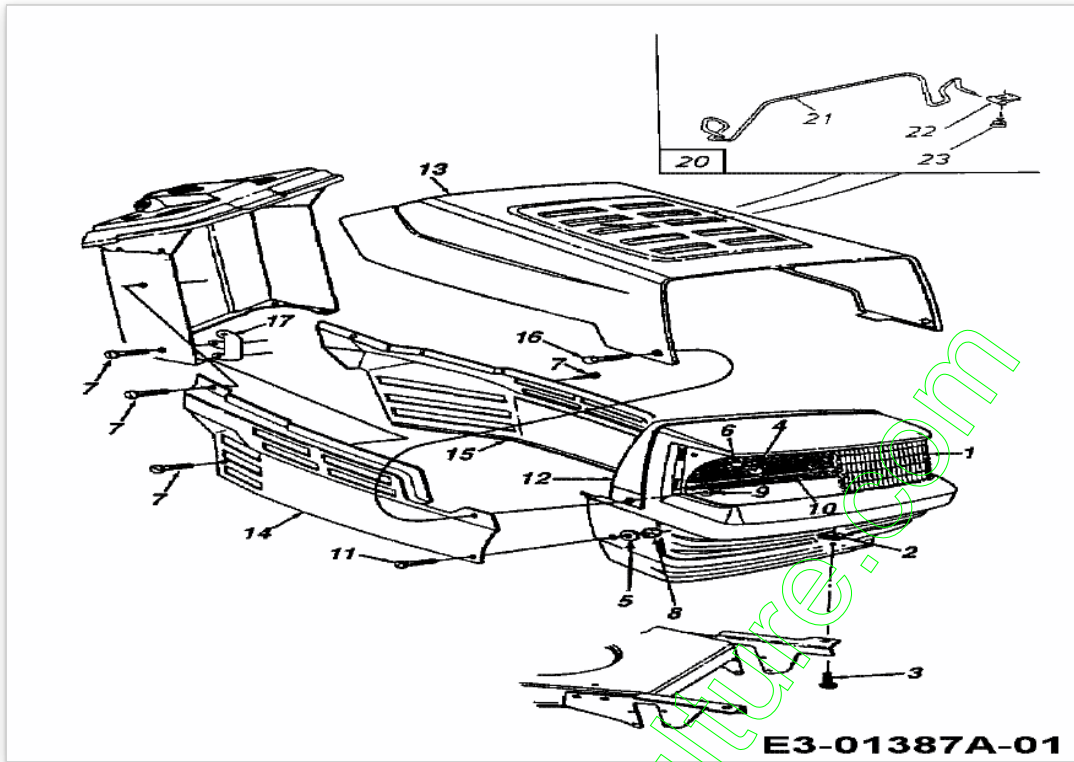

www.emc-motoculture.com

Position	Numéro de lapièce	#	Appellation I	Appellation II
1	731-1099A	1	OPTIQUE DE PHARE	w/o ICON
2	712-0211	2	SKT-MUTTER	712-0211
3	710-0118	2	VIS	FINISH:PHOS & OIL
4	725-0963	2	AMPOULE ELECTRIQUE	FINISH:
5	736-0270	2	RONDELLE GROWER	FINISH:MTD SPEC-100016
6	725-1651	2	PORTE AMPOULE	925-1651
7	710-0599	6	VIS A SIX PANS CREUX	FINISH:MTD SPEC-101617
8	712-3006	2	ECROU HEXAGONAL	FINISH:SPEC-100015
9	712-3027	2	ECROU HEXAGONAL 1/4-20:GRF	FINISH:MTD SPEC-100015
10	777-9206	1	FILM DE RÜFLECTEUR	GRILL-0/5-STYLE
11	710-0924	2	VIS EN TATE PLATE 1/4-20X;75"	FINISH:MTD STD 701-01000
12	731-1097D	1	CALANDRE	
13	783-0250	1	CAPOT	783-0250-0638/0674/0640/665
14	783-0150A	1	PART LATERALE DROITE	783-0150A-0638/0674
15	783-0151A	1	PART LATERALE GAUCHE	783-0151A-0638/0674
16	738-0952	2	AXE	.375 X .125: 1/4-20
17	783-0284	2	SUPPORT REVETEMENT LATERAL	FINISH:LACKIERT
20	753-0760	1	JEU DE PIÈCES DE MONTAGE POUR	3 u.5 STYLE 400/700 RIDER
21	732-0899	1	TRAVERSE	3 u.5 STYLE
22	726-0130	2	ECROU 10Z TYPE U	FINISH:PHOS & OIL SIEHE ZG.
23	710-0589	2	VIS PARKER HEX.:#10-16:0.750	FINISH:MTD SPEC-100016 TYPE 1

www.emc-motoculture.com