

CATALOGO DELLE PARTI DI RICAMBIO
 SPARE PARTS CATALOGUE
 CATALOGUES DES PIECES DE RECHANGE
 ERSATZTEILKATALOG

0	1	DADO
10	1	MOLLA GUIDA
10	2	VITE
9610	1	STAFFA DX
00010	4	DADO
00110	1	PROTEZIONE
515610	2	PIASTRINA
3135010	8	VITE
54515210	2	PIASTRINA
72960010	5	ROVESCIA
252304010	1	VITE
278900010	1	ROVESCIA
252304010	2	BUSSOLA
1215433010	1	ETICHETTA
2204196510	1	ETICHETTA
1435679710	1	DADO
1435765110	1	MOLLA GUIDA
1215433010	1	MOLLA GUIDA
86	2	VITE
37	2	STAFFA DX
38	1	STAFFA DX
39	4	DADO
		PROTEZIONE

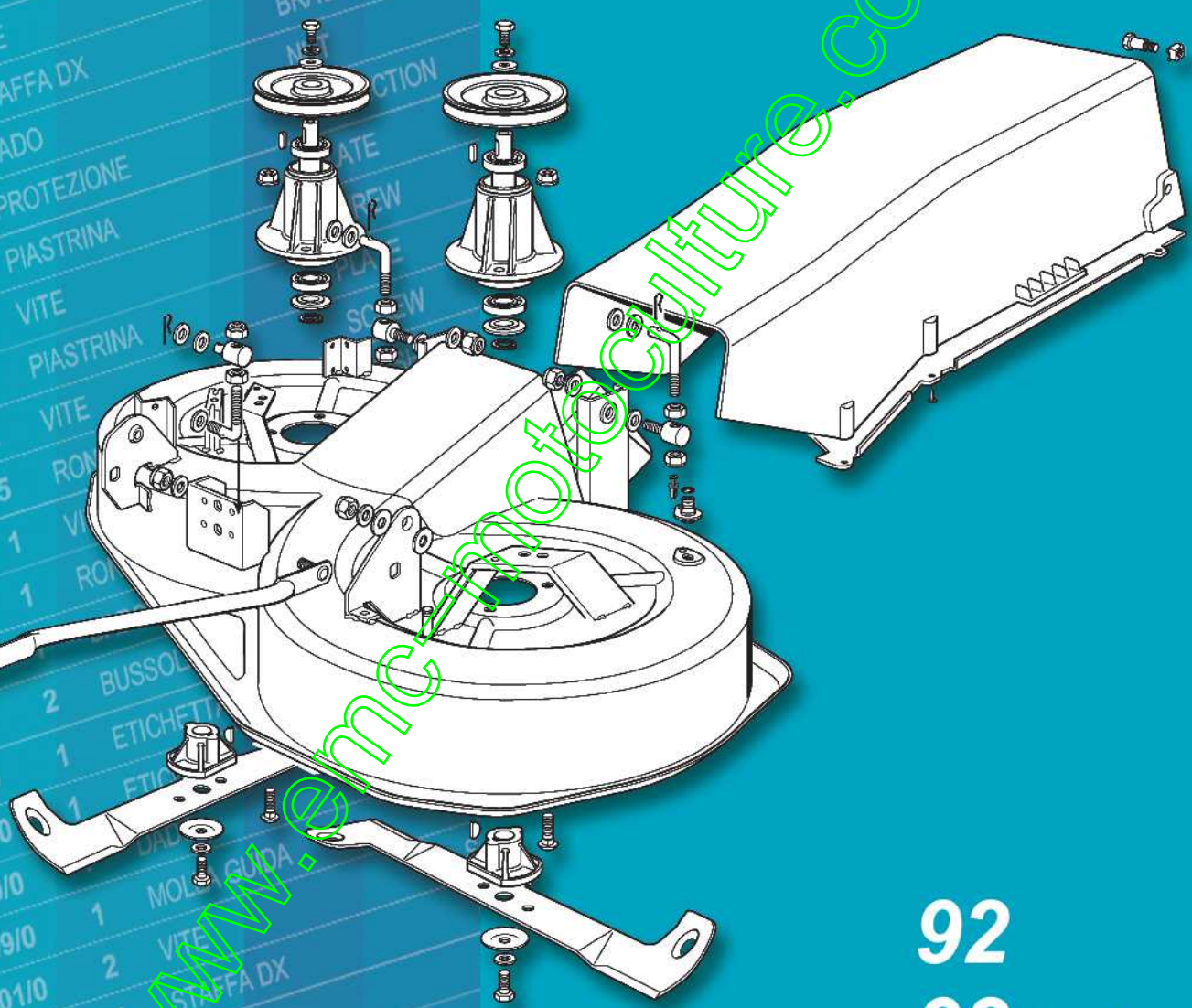

www.encculture.com

92
 92 hydro

2004

J	JP	JT	JR	JTP	JB	JX
92				92 hydro		

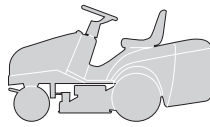

CATALOGO PARTI DI RICAMBIO
SPARE PARTS CATALOGUE
CATALOGUE DE PIÈCES
ERSATZTEILKATALOG

2004
000.0
1 / 10

COME USARE IL CATALOGO

HOW TO USE THE CATALOGUE

COMMENT UTILISER LE CATALOGUE

WIE IST DER KATALOG ZU BENUTZEN

1. Generalità

Questo catalogo contiene tutte le informazioni necessarie per ordinare correttamente i pezzi di ricambio.

1. General information

This catalogue contains all the information necessary for correctly ordering spare parts.

1. Généralités

Ce catalogue contient toutes les indications nécessaires pour commander correctement les pièces détachées.

1. Allgemeines

Dieser Katalog enthält alle Informationen, die für die korrekte Bestellung von Ersatzteilen erforderlich sind.

2. Struttura del catalogo

In ogni pagina del catalogo sono riportate le seguenti indicazioni:

2. Structure of the catalogue

Each page of the catalogue has these indications:

2. Structure du catalogue

Les indications suivantes sont reportées sur chaque page du catalogue:

2. Aufbau des Katalogs

Auf jeder Seite des Katalogs sind die folgenden Angaben wiedergegeben:

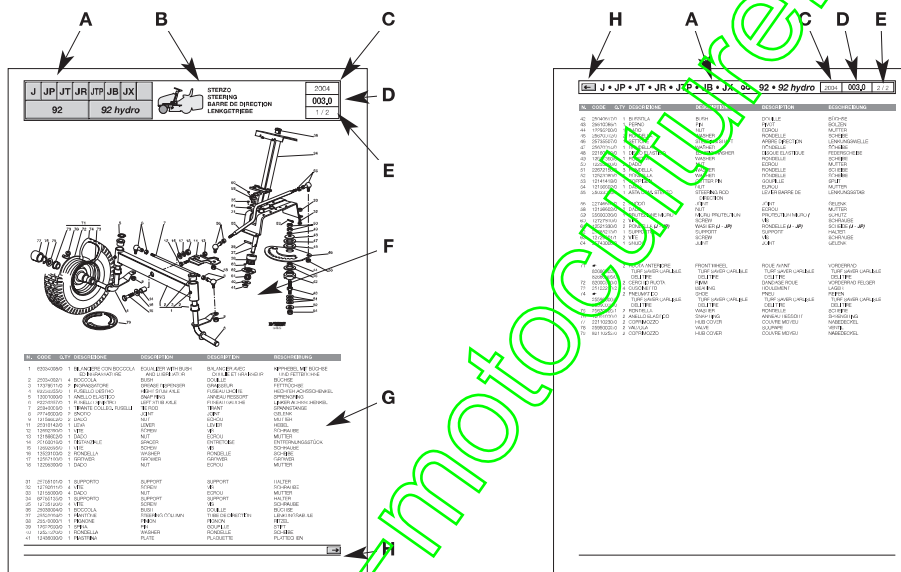

A. Macchina o serie di macchine per le quali la pagina è valida.

A. Machine or machine series to which the page applies.

A. La machine ou la série de machines auxquelles se réfère la page.

A. Maschine oder Serie der Maschine, für welche die Seite gültig ist.

B. Indicazione del gruppo con la raffigurazione in miniatura della sua collocazione sulla macchina.

B. Indication of the unit with a miniature drawing showing its position on the machine.

B. L'indication du groupe avec la représentation en miniature de sa position sur la machine.

B. Bezeichnung der Gruppe mit einer Miniaturdarstellung ihrer Anbringung auf der Maschine.

C. Anno di produzione della macchina a cui si riferisce.

C. Year of production of the machine concerned.

C. L'année de fabrication de la machine concernée.

C. Herstellungsjahr der betreffenden Maschine.

D. Numerazione progressiva della tavola, secondo il seguente criterio:

D. Progressive numbering of the table arranged as follows:

D. La numérotation progressive du tableau, selon le critère suivant:

D. Progressive Numerierung der Tafel nach folgendem Kriterium:

- le prime tre cifre indicano il numero progressivo;
- le eventuali lettere che seguono indicano le diverse versioni alternative di quel gruppo;
- la cifra dopo il punto indica un eventuale aggiornamento nel corso della annualità indicata al punto 3.

- the first three numbers are the progressive number;
- any letters that follow will indicate the various alternative versions of that unit;
- the number after the dot is for any updates during the year given at point 3.

- les trois premiers chiffres indiquent le numéro progressif;
- les éventuelles lettres qui suivent indiquent les différentes versions alternatives de ce groupe;
- le chiffre après le point indique l'éventuelle mise à jour effectuée au cours de l'année indiquée au point 3.

- die ersten drei Ziffern bezeichnen die progressive Nummer;
- die eventuellen Buchstaben, die folgen, bezeichnen die verschiedenen alternativen Versionen dieser Gruppe;
- die Ziffer nach dem Punkt bezeichnet einen eventuellen neueren Stand im Laufe des Jahrgangs, der in Punkt 3 angegeben ist.

Esempio:

Example:

Exemple

Beispiel:

005a.0 =
 005 Gruppo Motore
 a 13 HP TECUMSEH
 .0 Prima stesura

005a.0 =
 005 Engine unit
 a 13 HP TECUMSEH
 .0 First copy

005a.0 =
 005 Groupe Moteur
 a 13 HP TECUMSEH
 .0 Première rédaction

005a.0 =
 005 Motorgruppe
 a 13 HP TECUMSEH
 .0 Erste Ausgabe





E. Numero della pagina e numero totale delle pagine necessarie per la descrizione del gruppo.

F. Vista esplosa del gruppo.

G. Descrizione completa dei singoli particolari, con codice e quantità di pezzi.

H. Indicazione della presenza di altre pagine di seguito.

Nelle pagine di seguito, sono riportate nuovamente le indicazioni relative ai punti A - C - D - E - G e H.

E. Page number and total number of pages necessary for the description of the unit.

F. Exploded view of the unit.

G. Full description of each part, with code number and number of pieces.

H. Indication of additional pages.

The additional pages repeat the indications as at points A - C - D - E - G and H.

E. Numéro de la page et nombre total des pages nécessaires pour la description du groupe.

F. Vue éclatée du groupe.

G. Description complète de chaque élément, avec code et quantité des pièces.

H. Indication de la présence d'autres pages successives.

Les pages qui suivent reportent, elles aussi, les indications concernant les points A - C - D - E - G et H.

E. Seitenzahl und Gesamtzahl der Seiten, die für die Beschreibung der Gruppe erforderlich sind.

F. Explosionszeichnung der Gruppe.

G. Vollständige Beschreibung der Einzelteile, mit Kodenummer und Menge der Teile.

H. Angabe über die Präsenz weiterer folgender Seiten.

Auf den nachfolgenden Seiten sind die Bezeichnungen, die sich auf die Punkte A - C - D - E - G und H beziehen, erneut wiedergegeben.

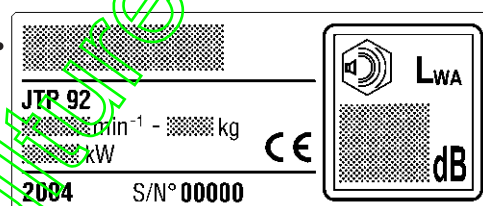
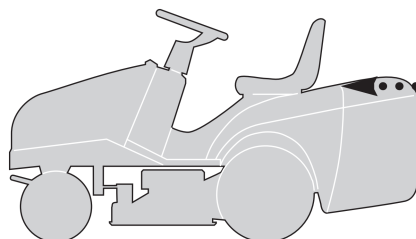

3. Ordine di ricambi

Prima di formulare un ordine di ricambi, accertare che il catalogo corrisponda all'anno di costruzione della macchina, e riportato sulla targhetta di identificazione.

Ogni ordine di ricambi deve necessariamente contenere:

- modello della macchina;
- quantità di pezzi richiesta;
- descrizione (eventuale);
- numero di codice del pezzo;
- destinatario
- mezzo di spedizione.

Esempio di ordinazione:

Su una macchina J92 del 2004, con motore TECUMSEH da 13 HP si deve sostituire il silenziatore di scarico. Tale particolare è raffigurato nella tavola **005a.0** alla posizione **16**, a cui corrisponde il codice **82750005/0**.

L'ordinazione sarà quindi:

per J92:
n. 1 silenziatore cod. 82750005/0
da inviare a
a mezzo

Nota

Per le parti non codificate del motore e della trasmissione contrassegnate con (*), occorre rivolgersi al Costruttore.

3. Spare parts order

Before putting in an order for spare parts, make sure that the catalogue is the one applying to the machine's year of manufacture, as shown on the identification plate attached to the machine.

Each spare parts order must include:

- the model of the machine;
- the number of parts required;
- description (if incidental);
- the code number for the item;
- the destination;
- the method of shipping.

An example of an order:

The exhaust pipe silencer on a J92 machine, produced in 2004 with an TECUMSEH 13 HP engine, must be replaced. This part is shown in table **005a.0** in position **16**, and has the code number **82750005/0**.

The order will therefore be:

for J92:
1 silencer - code 82750005/0
to be sent to
method of shipping

Nota

For parts of the engine and the transmission without code numbers, marked by (*), it's necessary to contact the manufacturer.

3. Commande pièces détachées

Avant de passer une commande pour des pièces détachées, s'assurer que le catalogue est celui correspondant à l'année de fabrication de la machine reportée sur la plaquette d'identification.

Chaque commande de pièces détachées doit obligatoirement contenir:

- modèle de la machine;
- quantité de pièces demandée;
- description (éventuelle);
- numéro de code de la pièce;
- le destinataire;
- le moyen de transport.

Exemple de commande:

Sur une machine J92 du 2004, avec moteur TECUMSEH de 13 CH, il faut remplacer le silencieux d'échappement. Cette pièce est représentée sur le tableau **005a.0** à la position **16**, correspondant au code **82750005/0**.

La commande sera donc formulée de la façon suivante:

pour J92:
1 silencieux - code 82750005/0
à envoyer à
par

Remarque

Pour les pièces non codées du moteur et de la transmission, indiquées avec (*), il faut s'adresser au Fabricant.

3. Ersatzteilbestellungen

Ehe eine Ersatzteilbestellung geschrieben wird, muß man sich vergewissern, daß der Katalog mit dem Herstellungsjahr der Maschine übereinstimmt, oder mit dem auf dem Kennzeichenschild wiedergegeben.

Jede Ersatzteilbestellung muß enthalten:

- Modell der Maschine;
- Menge der angeforderten Teile;
- Bezeichnung (eventuell);
- Artikelnummer des Teils;
- Empfänger;
- Versandart.

Beispiel einer Bestellung:

Auf einer Maschine J92 von 2004, mit Motor TECUMSEH mit 13 PS muß der Auspufftopf ersetzt werden. Dieses Einzelteil ist auf der Tafel **005a.0** unter der Position **16**, dargestellt, der dem Code **82750005/0** entspricht.

Die Bestellung lautet demnach:

Für J92:
1 Auspuff - Kode 82750005/0
zu versenden an
mit

Anmerkung

Für die nicht codierten Teile des Motors und des Antriebs, die mit (*) gekennzeichnet sind, muß man sich an den Hersteller wenden.

J	JP	JT	JR	JTP	JB	JX	
---	----	----	----	-----	----	----	--

92

92 hydro

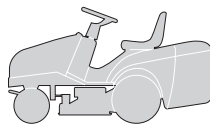



INDICE DELLE TAVOLE
INDEX OF TABLES
SOMMAIRE DES TABLEAUX
INHALT DER TAFELN

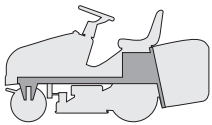
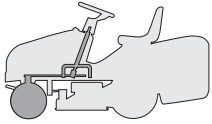
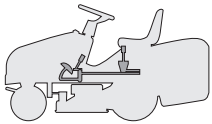
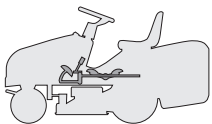
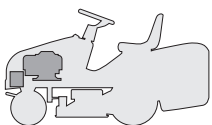
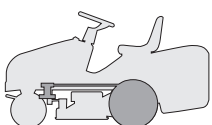
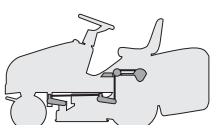

2004

000.0

3 / 10

GRUPPO / UNIT / GROUPE / GRUPPE	J - JP - JT - JR - JTP - JB - JX	
	92	92 Hydro
 <p>TELAIO CHASSIS CHASSIS RAHMENSATZ</p>	001	001
<p>CORROZZERIA / BODY CARROSSERIE / KARROSSERIE</p> <p>J</p> <p>JP</p> <p>JT</p> <p>JR</p> <p>JTP</p> <p>JB</p> <p>JX</p>	002 002a 002b 002c 002d 002e 002f	002 002a 002b 002c 002d 002e 002f
 <p>STERZO STEERING BARRE DE DIRECTION LENKGETRIEBE</p>	003	003
 <p>COMANDO FRENO E COMANDO CAMBIO BRAKE AND GEARBOX CONTROLS COMMANDE FREIN ET BOITE DE VITESSE BREMSE UND WECHSEL ANTRIEB</p>	004M	-
 <p>COMANDO TRASMISSIONE E FRENO DRIVE AND BRAKE CONTROLS COMMANDE TRANSMISSION ET FREIN GETRIEBE UND BREMSE ANTRIEB</p>	-	004Y
 <p>MOTORE ENGINE MOTEUR MOTOR</p> <p>12 - 12,5 - 13,5 HP B&S</p> <p>13 - 13,5 HP TECUMSEH</p> <p>15 - 15,5 HP B&S</p> <p>HONDA GCV 520</p>	005 005a 005b 005c	005 005a 005b 005c
 <p>TRASMISSIONE TRANSMISSION TRANSMISSION GETRIEBE</p>	006M	006Y
 <p>SOLLEVAMENTO PIATTO DI TAGLIO CUTTING PLATE LIFTING SOULEVEMENT PLATEAU DE COUPE SCHNEIDWERKZEUG AUFHEBESATZ</p>	007	007
 <p>PIATTO DI TAGLIO (1) CUTTING PLATE (1) PLATEAU DE COUPE (1) SCHNEIDWERKZEUG (1)</p>	008	008

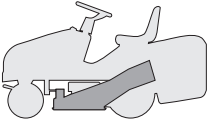
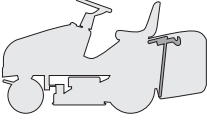
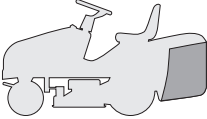
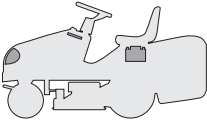
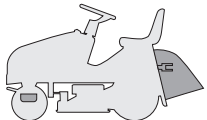

GRUPPO / UNIT / GROUPE / GRUPPE	J - JP - JT - JR - JTP - JB - JX	
	92	92 Hydro
 PIATTO DI TAGLIO (2) CUTTING PLATE (2) PLATEAU DE COUPE (2) SCHNEIDWERKZEUG (2) A profilo squadrato / with square profile à profil carré / mit kantigem Profil A profilo arrotondato / with round profile à profil arrondi / abgerundetem Profil.....	009 009a	009 009a
 SACCO (1. - PARTE FISSA) GRASSCATCHER (1. - FIXED PART) BAC (1. - PARTIE FIXE) AUFFANGSACK (1. - FESTER TEIL)	010	010
 SACCO (2. - PARTE MOBILE) GRASSCATCHER (2. - MOBILE PART) BAC (2. - PARTIE MOBILE) AUFFANGSACK (2. - BEWEGLICHER TEIL)	011	011
 PARTI ELETTRICHE ELECTRICAL PARTS PARTIES ELECTRIQUES ELETRISCHETEILE B&S - TECUMSEH HONDA	012 012a	012 012a
 ACCESSORI A RICHIESTA OPTIONALS ON REQUEST ACCESSOIRES SUR DEMANDE ZUBEHOERE NACH ANFRAGE	013	013
 ETICHETTE LABELS ETIQUETTES KLEBZETTEL	014	014

CODE	TABLE	N.	Q.TY	CODE	TABLE	N.	Q.TY	CODE	TABLE	N.	Q.TY
25033060/0	009.0	2	2	25120151/0	002b.0	11	1	25430209/0	006Y.0	82	8
25033060/0	009a.0	2	2	25120151/0	002c.0	11	1	25430215/0	002b.0	8	2
25034002/1	003.0	2	4	25120151/0	002e.0	11	1	25430215/0	002c.0	8	2
25034002/1	004Y.0	55	2	25120164/1	002.0	11	1	25430215/0	002e.0	8	2
25038002/1	006M.0	8	2	25120164/1	002a.0	11	1	25430219/0	006M.0	19	1
25038002/1	006Y.0	8	2	25120179/0	002d.0	11	1	25430219/0	006Y.0	19	1
25038004/0	003.0	36	1	25120179/0	002f.0	11	1	25430220/0	010.0	15	1
25040617/0	003.0	42	1	25120230/0	002.0	53	1	25430223/2	002.0	47	1
25060102/0	008.0	45	1	25120230/0	002a.0	53	1	25430223/2	002a.0	47	1
25060103/0	008.0	53	1	25120230/0	002b.0	53	1	25430223/2	002b.0	47	1
25060111/0	008.0	45	1	25120230/0	002c.0	53	1	25430223/2	002c.0	47	1
25060112/0	008.0	53	1	25120230/0	002d.0	53	1	25430223/2	002d.0	47	1
25065012/0	012.0	23	1	25120230/0	002e.0	53	1	25430223/2	002e.0	47	1
25065014/1	012.0	22	1	25122000/1	001.0	75	2	25430223/2	002f.0	47	1
25065014/1	012a.0	22	1	25122200/2	003.0	73	4	25430226/0	004M.0	36	1
25065017/0	012.0	24	1	25140093/0	013.0	72	1	25430227/0	008.0	77	1
25065025/0	012.0	32	1	25160007/0	008.0	30	1	25430229/0	008.0	23	2
25065025/0	012a.0	32	1	25160008/0	006M.0	20	1	25430230/0	012.0	26	1
25076802/0	002b.0	6	1	25160008/0	006Y.0	20	1	25430230/0	012a.0	26	1
25076808/0	002d.0	7	1	25160013/0	007.0	12	1	25430232/0	010.0	5	1
25076858/0	002f.0	1	1	25160014/0	006M.0	36	1	25430234/0	004M.0	18	1
25108004/0	009.0	91	1	25160016/0	003.0	14	1	25430234/0	004Y.0	32	1
25108004/0	009a.0	91	1	25160017/0	006M.0	10	1	25430236/0	004M.0	8	1
25108025/0	002f.0	8	1	25160017/0	006Y.0	10	1	25430236/0	004Y.0	9	1
25109521/1	006M.0	55	2	25160018/0	006M.0	35	1	25430245/0	013.0	75	1
25109521/1	006Y.0	35	2	25160024/1	006Y.0	30	1	25463200/0	009.0	20	2
25110126/1	002a.0	71	1	25160026/0	004M.0	11	1	25463200/0	009a.0	20	2
25110127/2	002a.0	61	1	25160030/0	006Y.0	29	1	25470901/0	007.0	4	1
25110178/2	002.0	71	1	25160031/0	006Y.0	76	2	25485001/0	002c.0	5	1
25110178/2	002a.0	71	1	25160501/0	009.0	9	1	25485002/0	002a.0	5	1
25110178/2	002b.0	71	1	25160501/0	009.0	15	1	25510011/0	007.0	5	1
25110178/2	002c.0	71	1	25160501/0	009a.0	9	1	25510021/1	013.0	43	1
25110178/2	002d.0	71	1	25160501/0	009a.0	15	1	25510022/0	013.0	10	2
25110178/2	002e.0	71	1	25190091/0	009.0	92	1	25510023/1	002b.0	3	2
25110178/2	002f.0	71	1	25190091/0	009a.0	92	1	25510023/1	002d.0	3	2
25110179/1	002.0	61	1	25207120/0	002.0	2	1	25510024/0	007.0	52	1
25110179/1	002a.0	61	1	25207124/0	002f.0	3	1	25510024/0	007.0	62	1
25110179/1	002b.0	61	1	25207200/0	009.0	7	1	25510032/0	007.0	20	1
25110179/1	002c.0	61	1	25207200/0	009.0	13	1	25510035/0	004M.0	31	1
25110179/1	002d.0	61	1	25207200/0	009a.0	7	1	25510036/1	006M.0	31	1
25110179/1	002e.0	61	1	25207200/0	009a.0	13	1	25510036/1	006Y.0	25	1
25110179/1	002f.0	61	1	25253004/0	013.0	79	2	25510039/0	002a.0	3	2
25110196/1	002.0	71	1	25260000/0	002b.0	10	2	25510039/0	002c.0	3	2
25110196/1	002a.0	71	1	25260000/0	002c.0	10	2	25510040/1	006M.0	14	1
25110196/1	002b.0	71	1	25260000/0	002d.0	10	2	25510040/1	006Y.0	14	1
25110196/1	002c.0	71	1	25260000/0	002e.0	10	2	25510040/1	007.0	32	1
25110196/1	002d.0	71	1	25260000/0	002f.0	10	2	25510042/0	010.0	6	2
25110196/1	002e.0	71	1	25270301/0	008.0	38	1	25510045/0	002.0	3	2
25110198/1	002.0	71	1	25270303/1	006M.0	52	1	25510045/0	002.0	3	2
25110198/1	002a.0	71	1	25270304/1	008.0	40	1	25510054/0	004Y.0	65	1
25110198/1	002b.0	71	1	25270316/0	008.0	49	1	25510060/0	004M.0	7	1
25110198/1	002d.0	71	1	25270318/0	001.0	28	1	25510061/0	009.0	94	2
25110198/1	002e.0	71	1	25280000/1	013.0	77	1	25510061/0	009a.0	94	2
25110199/1	002.0	61	1	25318124/0	010.0	33	1	25510065/1	003.0	43	1
25110199/1	002a.0	61	1	25318128/0	004M.0	46	1	25510066/0	004Y.0	66	1
25110199/1	002b.0	61	1	25318142/0	003.0	11	1	25510067/1	004Y.0	8	1
25110199/1	002c.0	61	1	25318157/0	006Y.0	52	1	25510068/0	002e.0	3	2
25110199/1	002d.0	61	1	25394007/0	013.0	73	1	25510068/0	002f.0	27	2
25110199/1	002e.0	61	1	25394501/0	002.0	34	1	25510069/0	007.0	72	1
25110201/1	002.0	61	1	25394501/0	002a.0	34	1	25510077/0	013.0	74	1
25110201/1	002a.0	61	1	25394501/0	002b.0	34	1	25510080/0	010.0	13	1
25110201/1	002b.0	61	1	25394501/0	002c.0	34	1	25519997/1	013.0	22	1
25110201/1	002d.0	61	1	25394501/0	002d.0	34	1	25520004/0	003.0	37	1
25110201/1	002e.0	61	1	25394501/0	002e.0	34	1	25547015/0	002b.0	2	1
25110263/1	002.0	20	1	25394501/0	002f.0	34	1	25547015/0	002c.0	2	1
25110263/1	002a.0	20	1	25394504/1	007.0	7	1	25547015/0	002e.0	2	1
25110263/1	002b.0	20	1	25394508/0	011.0	8	1	25547016/2	002b.0	2	1
25110263/1	002c.0	20	1	25394510/0	004M.0	41	1	25547016/2	002c.0	2	1
25110263/1	002d.0	20	1	25394510/0	008.0	87	1	25547016/2	002e.0	2	1
25110263/1	002e.0	20	1	25410858/0	002b.0	5	1	25547024/0	002b.0	2	1
25110263/1	002f.0	20	1	25410860/0	002d.0	5	1	25547024/0	002e.0	2	1
25110264/1	002.0	19	1	25410861/0	002d.0	6	1	25547025/1	002.0	2	1
25110264/1	002a.0	19	1	25410865/0	002c.0	6	1	25547025/1	002a.0	2	1
25110264/1	002b.0	19	1	25410866/0	002a.0	6	1	25547026/0	002d.0	2	1
25110264/1	002c.0	19	1	25410867/0	002a.0	7	1	25547026/0	002.0	2	1
25110264/1	002d.0	19	1	25410868/0	002e.0	7	1	25547026/0	002a.0	2	1
25110264/1	002e.0	19	1	25410869/0	002e.0	6	1	25547028/0	002d.0	2	1
25110264/1	002f.0	19	1	25410874/0	002f.0	5	1	25547028/0	002.0	2	1
25110265/0	004Y.0	52	1	25410875/0	002f.0	6	1	25547028/0	002a.0	2	1
25110266/0	004Y.0	53	1	25430205/0	001.0	70	2	25547028/0	002d.0	2	1
25110267/0	004Y.0	2	1	25430208/0	007.0	8	1	25547033/1	002.0	43	1
25110269/0	004M.0	2	1	25430209/0	006M.0	82	8	25547033/1	002a.0	43	1
								25547033/1	002b.0	43	1

www.enrmoreculture.com

CODE	TABLE	N.	Q.TY	CODE	TABLE	N.	Q.TY	CODE	TABLE	N.	Q.TY
25547033/1	002c.0	43	1	25601555/0	006Y.0	24	1	25785062/1	002c.0	17	1
25547033/1	002d.0	43	1	25601555/0	008.0	29	1	25785077/0	010.0	20	2
25547033/1	002e.0	43	1	25601557/0	007.0	19	1	25785101/0	003.0	31	1
25547033/1	002f.0	43	1	25601564/0	008.0	2	1	25785119/1	001.0	61	1
25547037/1	007.0	25	2	25601570/0	006M.0	34	2	25785213/0	003.0	62	1
25547039/0	004M.0	3	1	25601570/0	006Y.0	28	2	25795000/1	002.0	92	1
25547039/0	004Y.0	3	1	25601573/0	009.0	28	2	25795000/1	002a.0	92	1
25547041/0	004M.0	4	1	25601573/0	009a.0	28	2	25795000/1	002b.0	92	1
25547041/0	007.0	29	2	25605000/1	007.0	3	1	25795000/1	002c.0	92	1
25547049/0	004M.0	19	2	25650046/0	001.0	44	1	25795000/1	002d.0	92	1
25547049/0	004Y.0	33	2	25650055/0	001.0	62	2	25795000/1	002e.0	92	1
25547053/0	013.0	7	1	25650056/0	001.0	68	1	25795000/1	002f.0	92	1
25547054/1	002.0	12	1	25670005/1	003.0	75	2	25840002/0	006M.0	24	1
25547089/0	002.0	104	1	25670005/1	006M.0	75	2	25840003/2	007.0	51	1
25547089/0	002a.0	104	1	25670005/1	006Y.0	80	2	25840003/2	007.0	61	1
25547089/0	002b.0	104	1	25670007/0	009.0	31	2	25840005/0	006M.0	17	1
25547089/0	002c.0	104	1	25670007/0	009a.0	31	2	25840005/0	006Y.0	17	1
25547089/0	002d.0	104	1	25670008/1	007.0	54	1	25840006/0	003.0	7	1
25547091/0	002.0	105	1	25670008/1	007.0	56	2	25840007/0	013.0	78	1
25547091/0	002a.0	105	1	25670008/1	007.0	64	1	25840007/0	007.0	71	1
25547091/0	002b.0	105	1	25670008/1	007.0	66	2	25869010/0	005a.0	2	1
25547091/0	002c.0	105	1	25670008/1	007.0	73	1	25869016/0	005.0	2	1
25547091/0	002d.0	105	1	25670008/1	007.0	76	2	25869016/0	005b.0	2	1
25547101/0	001.0	23	2	25670008/1	009.0	54	8	25869027/0	005c.0	2	1
25547109/1	002e.0	104	2	25670008/1	009a.0	54	8	25869029/1	011.0	7	1
25547109/1	002f.0	104	2	25670011/0	006M.0	15	2	25869031/0	013.0	3	1
25547144/0	002a.0	2	1	25670011/0	006Y.0	15	2	25943001/0	001.0	73	2
25570000/1	003.0	38	1	25670011/0	006Y.0	55	1	25950000/0	006M.0	78	2
25580007/0	008.0	42	1	25670011/0	007.0	35	2	25950000/0	006Y.0	74	2
25580012/0	002.0	8	1	25670011/0	008.0	20	1	25950002/0	003.0	78	2
25580012/0	002a.0	8	1	25670012/0	003.0	45	2	25961201/0	002.0	51	1
25580013/0	002.0	9	1	25670014/0	003.0	47	1	25961201/0	002a.0	51	1
25580013/0	002a.0	9	1	25670017/0	006Y.0	77	2	25961201/0	002b.0	51	1
25580019/0	001.0	21	1	25722415/0	012.0	2	1	25961201/0	002c.0	51	1
25580023/0	001.0	26	2	25722415/0	012a.0	2	1	25961201/0	002d.0	51	1
25590000/0	003.0	74	2	25722453/1	002.0	41	1	25961201/0	002e.0	51	1
25590001/0	006M.0	73	2	25722453/1	002a.0	41	1	25961212/0	002f.0	51	1
25590001/0	006Y.0	73	2	25722453/1	002b.0	41	1	27063021/0	002.0	54	1
25590002/0	003.0	74	2	25722453/1	002c.0	41	1	27063021/0	002a.0	54	1
25590003/0	006M.0	73	2	25722453/1	002d.0	41	1	27063021/0	002b.0	54	1
25590003/0	006Y.0	73	2	25722453/1	002e.0	41	1	27063021/0	002c.0	54	1
25598050/0	005.0	10	1	25722463/0	002.0	41	1	27063021/0	002d.0	54	1
25598050/0	005a.0	10	1	25730005/1	002.0	25	1	27063021/0	002e.0	54	1
25598050/0	005b.0	10	1	25730005/1	002a.0	25	1	27063021/0	002f.0	54	1
25598051/0	005c.0	9	1	25730012/0	002d.0	26	1	27395050/1	004M.0	23	1
25600020/0	002.0	81	1	25730014/0	002e.0	26	1	27395050/1	004Y.0	37	1
25600020/0	002a.0	81	1	25730016/0	002f.0	26	1	27430561/0	012a.0	57	1
25600020/0	002b.0	81	1	25735116/1	002.0	91	1	27546019/0	004Y.0	80	1
25600020/0	002c.0	81	1	25735116/1	002a.0	91	1	33215000/0	012a.0	55	1
25600020/0	002d.0	81	1	25735116/1	002b.0	91	1	33320504/0	012.0	30	1
25600020/0	002e.0	81	1	25735116/1	002c.0	91	1	33320504/0	012a.0	30	1
25600020/0	002f.0	81	1	25735116/1	002d.0	91	1	33320506/0	012.0	29	4
25600021/1	002.0	82	1	25735116/1	002e.0	91	1	33320506/0	012a.0	29	4
25600021/1	002a.0	82	1	25735116/1	002f.0	91	1	33340033/0	012.0	4	1
25600021/1	002b.0	82	1	25735506/1	007.0	15	1	33340033/0	012a.0	4	1
25600021/1	002c.0	82	1	25735507/0	003.0	46	1	33340035/0	012a.0	56	1
25600021/1	002d.0	82	1	25743000/0	003.0	64	1	33500030/0	012.0	20	2
25600021/1	002e.0	82	1	25755008/0	001.0	76	2	33500030/0	012a.0	20	2
25600021/1	002f.0	82	1	25755016/0	001.0	81	1	35061980/0	006Y.0	5	1
25600031/0	005a.0	24	1	25755025/1	001.0	84	1	35062000/1	006M.0	5	1
25600033/0	002.0	62	1	25755031/0	010.0	12	1	35065700/0	008.0	34	1
25600033/0	002a.0	62	1	25774247/0	006M.0	48	2	81004346/3	009a.0	23	1
25600033/0	002b.0	62	1	25774251/0	010.0	35	1	82000207/0	002.0	31	1
25600033/0	002c.0	62	1	25774258/0	002.0	93	1	82000207/0	002a.0	31	1
25600033/0	002d.0	62	1	25774258/0	002a.0	93	1	82000207/0	002b.0	31	1
25600033/0	002e.0	62	1	25774258/0	002b.0	93	1	82000207/0	002c.0	31	1
25600034/0	002.0	63	1	25774258/0	002c.0	93	1	82000207/0	002d.0	31	1
25600034/0	002a.0	63	1	25774258/0	002d.0	93	1	82000207/0	002e.0	31	1
25600034/0	002b.0	63	1	25774258/0	002e.0	93	1	82000207/0	002f.0	31	1
25600034/0	002c.0	63	1	25774258/0	002f.0	93	1	82000361/0	004M.0	17	1
25600034/0	002d.0	63	1	25774275/0	004M.0	12	1	82000361/0	004Y.0	31	1
25600034/0	002e.0	63	1	25774275/0	004Y.0	11	1	82000381/2	007.0	24	1
25600036/0	003.0	59	1	25774289/0	004Y.0	77	1	82000403/0	007.0	10	1
25600041/0	010.0	31	1	25774299/0	001.0	29	2	82000465/1	010.0	4	1
25600042/0	010.0	32	1	25774327/0	010.0	11	1	82000474/1	009.0	51	2
25600061/0	002f.0	62	1	25785035/3	002.0	17	1	82000474/1	009a.0	51	2
25600065/0	002f.0	63	1	25785035/3	002a.0	17	1	82000499/0	008.0	24	1
25601547/1	006M.0	1	1	25785053/1	002d.0	17	1	82000505/0	001.0	32	1
25601548/1	006Y.0	1	1	25785053/1	002e.0	17	1	82000590/0	003.0	72	2
25601554/0	006M.0	11	1	25785053/1	002f.0	17	1	82000592/0	006M.0	72	2
25601554/0	006Y.0	11	1	25785057/0	001.0	91	1	82000592/0	006Y.0	72	2
25601555/0	006M.0	30	1	25785062/1	002b.0	17	1	82004344/1	009.0	23	1

CODE	TABLE	N.	Q.TY	CODE	TABLE	N.	Q.TY	CODE	TABLE	N.	Q.TY
82004345/1	009.0	22	1	82207203/0	009a.0	11	1				
82004352/0	009a.0	22	1	82230355/0	003.0	4	1				
82004353/0	009a.0	23	1	82230357/0	003.0	6	1				
82004354/0	009a.0	22	1	82300002/1	007.0	1	1				
82004603/0	007.0	18	1	82318133/0	006M.0	6	1				
82004604/3	008.0	85	1	82318133/0	006Y.0	6	1				
82033103/1	013.0	42	1	82318134/1	004M.0	35	1				
82034008/0	003.0	1	1	82318135/0	008.0	76	1				
82040070/0	012.0	19	1	82318137/0	007.0	28	1				
82040070/0	012a.0	19	1	82318139/0	007.0	2	1				
82040073/0	012.0	19	1	82318141/1	008.0	1	1				
82040073/0	012a.0	19	1	82318143/2	008.0	14	1				
82040082/2	012.0	10	1	82318148/0	008.0	15	1				
82040084/0	012a.0	10	1	82318183/0	004Y.0	59	1				
82040105/0	012.0	1	1	82394607/0	002f.0	4	1				
82040107/0	012a.0	1	1	82400002/0	013.0	2	1				
82040117/0	012.0	10	1	82500002/1	004M.0	1	1				
82076802/2	002b.0	1	1	82500008/0	004Y.0	51	1				
82076803/0	002b.0	1	1	82500017/0	004Y.0	1	1				
82076808/0	002b.0	1	1	82547021/3	001.0	41	1				
82076817/2	002c.0	1	1	82564034/1	009.0	1	1				
82076818/1	002c.0	1	1	82564048/0	009a.0	1	1				
82076841/2	002d.0	1	1	82564049/0	009a.0	—	1				
82076843/1	002d.0	1	1	82564050/0	009.0	—	1				
82076847/1	002d.0	1	1	82598005/2	005c.0	35	1				
82076897/1	002a.0	1	1	82598009/2	005.0	18	1				
82076898/0	002a.0	1	1	82598009/2	005b.0	18	1				
82076900/0	002a.0	1	1	82598017/0	005a.0	18	1				
82076902/1	002.0	1	1	82601503/0	006M.0	41	1				
82076903/0	002.0	1	1	82650039/0	011.0	6	1				
82076905/0	002.0	1	1	82650201/0	001.0	43	1				
82076917/1	002e.0	1	1	82680002/1	003.0	71	2				
82076918/0	002e.0	1	1	82680003/0	006M.0	71	2				
82076919/0	002e.0	1	1	82680003/0	006Y.0	71	2				
82076932/0	002a.0	1	1	82680005/0	003.0	71	2				
82105998/0	011.0	3	1	82680006/0	006Y.0	71	2				
82110001/3	002.0	18	1	82680006/0	006Y.0	71	2				
82110001/3	002a.0	18	1	82750003/0	005c.0	31	1				
82110001/3	002b.0	18	1	82750004/0	005.0	16	1				
82110001/3	002c.0	18	1	82750004/0	005b.0	16	1				
82110001/3	002d.0	18	1	82750005/0	005a.0	16	1				
82110001/3	002e.0	18	1	82774204/1	008.0	75	1				
82110001/3	002f.0	18	1	82774206/0	004M.0	34	1				
82110002/2	002.0	18	1	82774215/0	008.0	11	1				
82110002/2	002a.0	18	1	82774231/0	004Y.0	72	1				
82110002/2	002b.0	18	1	82785073/0	008.0	71	1				
82110002/2	002c.0	18	1	82785110/0	004Y.0	54	1				
82110002/2	002d.0	18	1	82785117/0	006Y.0	45	1				
82110002/2	002e.0	18	1	82785135/0	003.0	34	1				
82110004/2	002.0	18	1	82800014/1	011.0	2	1				
82110004/2	002a.0	18	1	82800015/0	011.0	1	1				
82110004/2	002b.0	18	1	82800017/1	010.0	1	1				
82110004/2	002d.0	18	1	82800019/0	001.0	3	1				
82110004/2	002e.0	18	1	82800021/0	001.0	4	1				
82110007/3	002.0	18	1	82800083/0	001.0	1	1				
82110007/3	002a.0	18	1	82869006/1	002d.0	101	1				
82110007/3	002b.0	18	1	82869011/0	002.0	101	1				
82110007/3	002c.0	18	1	82869011/0	002a.0	101	1				
82110007/3	002d.0	18	1	82869011/0	002b.0	101	1				
82110007/3	002e.0	18	1	82869011/0	002c.0	101	1				
82110007/3	002f.0	18	1	82869011/0	002e.0	101	1				
82110008/2	002.0	18	1	82869019/0	002f.0	101	1				
82110008/2	002a.0	18	1	99900030/6	013.0	21	1				
82110008/2	002b.0	18	1	99900038/0	013.0	71	1				
82110008/2	002c.0	18	1	99900050/0	013.0	1	1				
82110008/2	002d.0	18	1	99900080/2	013.0	41	1				
82110008/2	002e.0	18	1								
82110010/2	002.0	18	1								
82110010/2	002a.0	18	1								
82110010/2	002b.0	18	1								
82110010/2	002d.0	18	1								
82110010/2	002e.0	18	1								
82110015/2	002a.0	18	1								
82110016/2	002a.0	18	1								
82110252/0	003.0	79	2								
82110253/0	006M.0	81	2								
82110253/0	006Y.0	81	2								
82180016/1	011.0	16	1								
82180050/0	013.0	51	1								
82207202/0	009.0	5	1								
82207202/0	009a.0	5	1								
82207203/0	009.0	11	1								

www.erasmonoculture.com

J JP JT JR JTP JB JX

92

92 hydro

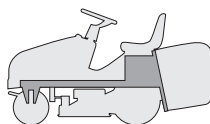

TELAIO
CHASSIS
CHASSIS
RAHMENSATZ

2004

001.0

1 / 2

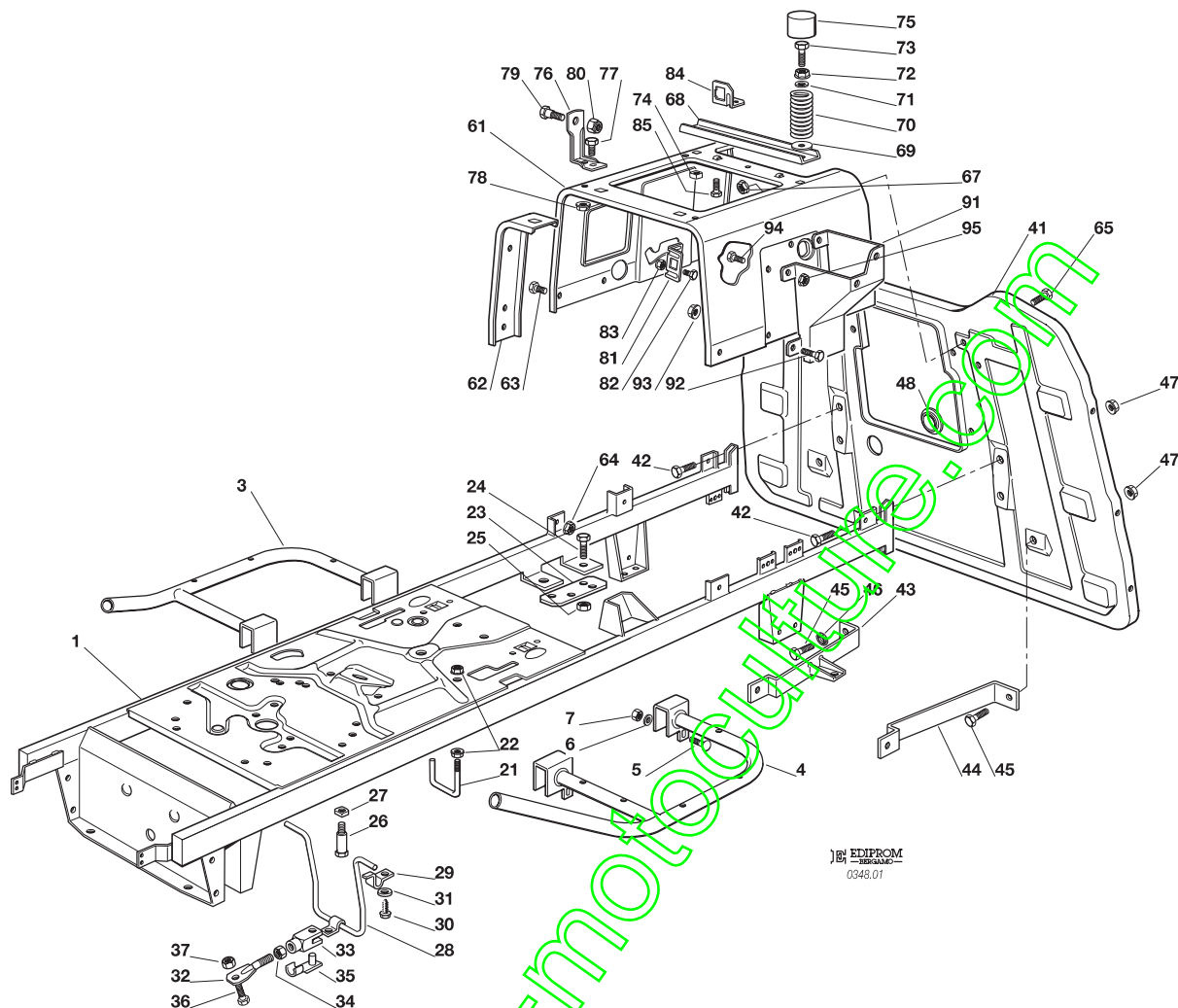

EDIPROM
0348.01

N.	CODE	Q.TY	DESCRIZIONE	DESCRIPTION	DESCRIPTION	BESCHREIBUNG
1	82800083/0	1	TELAIO	CHASSIS	CHASSIS	RAHMENSATZ
3	82800019/0	1	SUPPORTO PEDANA DESTRA	RIGHT FOOTBOARD SUPPORT	MARCHEPIED DROITE SUPPORT	RECHTE FUSSBRETTHALTER
4	82800021/0	1	SUPPORTO PEDANA SINISTRA	LEFT FOOTBOARD SUPPORT	SUPPORT MARCHEPIED GAUCHE	LINKE FUSSBRETTHALTER
5	12815240/0	4	VITE	SCREW	VIS	SCHRAUBE
6	12523040/0	4	ROSETTA	WASHER	RONDELLE	SCHEIBE
7	12154510/0	4	DADO	NUT	ECROU	MUTTER
21	25580019/0	1	PIOLO GUIDACINGHIA (hydro)	BELT GUIDE (hydro)	GUIDE DE COURROIRE (hydro)	RIEMENFÜHRUNG (hydro)
22	12292102/0	2	DADO (hydro)	NUT (hydro)	ECROU (hydro)	MUTTER (hydro)
23	25547101/0	2	PIASTRINA (hydro)	PLATE (hydro)	PLAQUETTE (hydro)	PLATTE (hydro)
24	12793102/0	2	VITE (hydro)	SCREW (hydro)	VIS (hydro)	SCHRAUBE (hydro)
25	12155000/0	2	DADO (hydro)	NUT (hydro)	ECROU (hydro)	MUTTER (hydro)
26	25580023/0	2	PIOLO GUIDACINGHIA (mecc.)	BELT GUIDE (mecc.)	GUIDE DE COURROIRE (mec.)	RIEMENFÜHRUNG (mecc.)
27	12360425/0	2	DADO (mecc.)	NUT (mecc.)	ECROU (mec.)	MUTTER (mecc.)
28	25270318/0	1	GUIDACINGHIA	BELT GUIDE	GUIDE DE COURROIRE	RIEMENFÜHRUNG
29	25774299/0	2	PIASTRINA	PLATE	PLAQUETTE	PLATTE
30	12734995/0	2	VITE	SCREW	VIS	SCHRAUBE
31	12523040/0	2	RONDELLA	WASHER	RONDELLE	SCHEIBE
32	82000505/0	1	TIRANTE	TIE ROD	TIRANT	SPANNSTANGE
33	18399000/0	1	FORCELLA	FORK	FOURCHE	GABEL
34	12292100/0	1	DADO	NUT	ECROU	MUTTER
35	18210200/0	1	CLIP	CLIP	CLIP	SPERRBOLZEN
36	12793102/0	1	VITE	SCREW	VIS	SCHRAUBE
37	12154210/0	1	DADO	NUT	ECROU	MUTTER
41	82547021/3	1	PIASTRA	PLATE	PLAQUE	PLATTE
42	12792611/0	2	VITE	SCREW	VIS	SCHRAUBE





N.	CODE	Q.TY	DESCRIZIONE	DESCRIPTION	DESCRIPTION	BESCHREIBUNG
43	82650201/0	1	RINFORZO DESTRO	PLATE STIFFENING, RIGHT	REINFORCEMENT PLAQUE,	RECHTE PLATTE-
44	25650046/0	1	RINFORZO SINISTRO	PLATE STIFFENING, LEFT	REINFORCEMENT PLAQUE	LINKE PLATTE-
45	12792611/0	4	VITE	SCREW	VIS	SCHRAUBE
46	12540260/0	1	ROSETTA	WASHER	RONDELLE	SCHEIBE
47	12293201/0	6	DADO	NUT	ECROU	MUTTER
48	22110275/0	1	TAPPO	CAP	BOUCHON	TANKVERSCHLUSS
61	25785119/1	1	SUPPORTO SEDILE	SEAT SUPPORT	SUPPORT SIEGE	SITZHALTER
62	25650055/0	2	RINFORZO	PLATE STIFFENING	REINFORCEMENT PLAQUE	PLATTEVERSTAERKUG
63	12790781/0	4	VITE	SCREW	VIS	SCHRAUBE
64	12292102/0	4	DADO	NUT	ECROU	MUTTER
65	12790781/0	4	VITE	SCREW	VIS	SCHRAUBE
67	12292102/0	4	DADO	NUT	ECROU	MUTTER
68	25650056/0	1	RINFORZO	PLATE STIFFENING	REINFORCEMENT PLAQUE	PLATTEVERSTAERKUNG
69	12523060/0	2	RONDELLA	WASHER	RONDELLE	SCHEIBE
70	25430205/0	2	MOLLA	SPRING	RESSORT	FEDER
71	12521350/0	2	RONDELLA	WASHER	RONDELLE	SCHEIBE
72	12293201/0	2	DADO	NUT	ECROU	MUTTER
73	25943001/0	2	VITE	SCREW	VIS	SCHRAUBE
74	12360420/0	2	DADO	NUT	ECROU	MUTTER
75	25122000/1	2	CUFFIA	HOOD	PROTECTEUR	SCHUTZKASTEN
76	25755008/0	2	SQUADRETTA	BRACKET	EQUERRE-SUPPORT	WINKEL
77	12792611/0	2	VITE	SCREW	VIS	SCHRAUBE
78	12293201/0	2	DADO	NUT	ECROU	MUTTER
79	22524970/2	2	PERNO	PIN	PYOT	BOLZEN
80	12155010/0	2	DADO	NUT	ECROU	MUTTER
81	25755016/0	1	SQUADRETTA	BRACKET	EQUERRE-SUPPORT	WINKEL
82	12789000/0	2	VITE	SCREW	VIS	SCHRAUBE
83	12154330/0	2	DADO	NUT	ECROU	MUTTER
84	25755025/1	1	SQUADRETTA	BRACKET	EQUERRE-SUPPORT	WINKEL
85	12731580/0	2	VITE	SCREW	VIS	SCHRAUBE
91	25785057/0	1	SUPPORTO	SUPPORT	SUPPORT	HALTER
92	12790781/0	2	VITE	SCREW	VIS	SCHRAUBE
93	12292102/0	2	DADO	NUT	ECROU	MUTTER
93	12790781/0	2	VITE	SCREW	VIS	SCHRAUBE
94	12292102/0	2	DADO	NUT	ECROU	MUTTER

www.emc-motoculture.com

J

JP

JT

JR

JTP

JB

JX

92

92 hydro

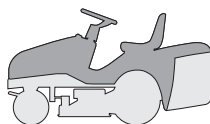

CARROZZERIA
BODY
CARROSSERIE
KARROSSERIE

2004

002.0

1 / 2

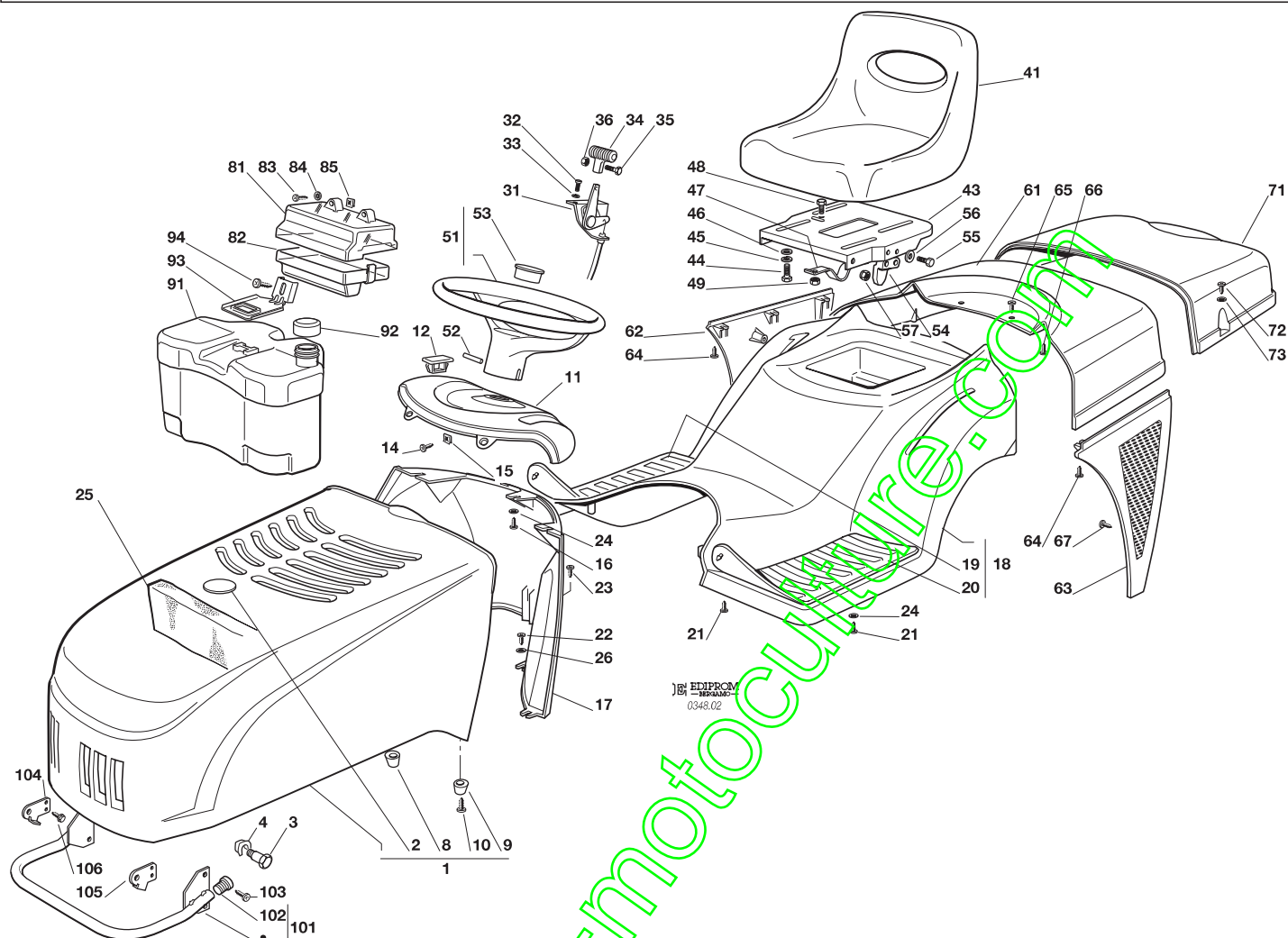

N.	CODE	Q.TY	DESCRIZIONE	DESCRIPTION	DESCRIPTION	BESCHREIBUNG
1	82076902/1	1	COFANO ROSSO	ENGINE HOOD RED	CAPOT ROUGE	HAUBESATZ ROT
	82076903/0		VERDE	GREEN	VERT	GRÜN
	82076905/0		BLU	BLUE	BLEU	BLAU
2	25547025/1	1	PIASTRINA ROSSA	PLATE RED	PLAQUE ROUGE	PLATTE ROT
	25547026/0		VERDE	GREEN	VERT	GRÜN
	25547028/0		BLU	BLUE	BLEU	BLAU
3	25510045/0	2	PERNO	PIN	PIVOT	BOLZEN
4	12436050/0	2	PIASTRINA	PLATE	PLAQUE	PLATTE
8	25580012/0	1	PIOLO DESTRO	RIGHT PIN	BONDON DROITE	RECHTE DÜBEL
9	25580013/0	1	PIOLO SINISTRO	LEFT PIN	BONDON GAUCHE	LINKE DÜBEL
10	12727356/0	2	VITE	SCREW	VIS	SCHRAUBE
11	25120164/1	1	CRUSCOTTO	DASHBOARD	TABLEAU COMMANDES	KONSOLE
12	25547054/1	1	PIASTRINA	PLATE	PLAQUE	PLATTE
14	12735110/0	2	VITE	SCREW	VIS	SCHRAUBE
15	12437502/0	2	PIASTRINA	PLATE	PLAQUE	PLATTE
16	12735402/0	3	VITE	SCREW	VIS	SCHRAUBE
17	25785035/3	1	SUPPORTO CRUSCOTTO	DASHBOARD SUPPORT	SUPPORT TABLEAU COMM.	KONSOLEHALTER
18	82110001/3	1	COPERTURA RUOTE ROSSO	WHEELS COVER RED	COUVRE-ROUES ROUGE	RADENKAPPE ROT
	82110002/2		VERDE	GREEN	VERT	GRÜN
	82110004/2		BLU	BLUE	BLEU	BLAU
18	82110007/3	1	COPERTURA RUOTE (hydro) ROSSO	WHEELS COVER (hydro) RED	COUVRE-ROUES (hydro) ROUGE	RADENKAPPE (hydro) ROT
	82110008/2		VERDE	GREEN	VERT	GRÜN
	82110010/2		BLU	BLUE	BLEU	BLAU
19	25110264/1	1	COPRIPEDANA DESTRA	RIGHT FOOTBOARDCOVER	COUVRE MARCHEPIED DRO.	RECHTE FUSSBRETTDECKEL
20	25110263/1	1	COPRIPEDANA SINISTRA	LEFT FOOTBOARD COVER	COUVRE MARCHEPIED GAU.	LINKE FUSSBRETTDECKEL
21	12735410/0	6	VITE	SCREW	VIS	SCHRAUBE
22	12735402/0	4	VITE	SCREW	VIS	SCHRAUBE





N.	CODE	Q.TY	DESCRIZIONE	DESCRIPTION	DESCRIPTION	BESCHREIBUNG
23	12728680/0	1	VITE	SCREW	VIS	SCHRAUBE
24	12523040/0	5	ROSETTA	WASHER	RONDELLE	SCHEIBE
25	25730005/1	1	SEPARATORE ASPIRAZ. 13 HP TECUMSEH	INTAKE SEPARATOR 13 HP TECUMSEH	SEPARATEUR ASPIRATIONS 13 HP TECUMSEH	AUGENABSCHIEDER 13 HP TECUMSEH
26	12523050/0	4	ROSETTA	WASHER	RONDELLE	SCHEIBE
31	82000207/0	1	ACCELERATORE	ACCELERATOR	ACCELERATEUR	GAS ZUG
32	12788512/0	2	VITE	SCREW	VIS	SCHRAUBE
33	12581200/0	2	GROWER	GROWER	GROWER	GROWER
34	25394501/0	1	MANOPOLINA	HANDLE	POIGNE	GRIFF
35	12726388/0	1	VITE	SCREW	VIS	SCHRAUBE
36	12290800/0	1	DADO	NUT	ECROU	MUTTER
41	25722453/1	1	SEDILE	SEAT	SIEGE	SITZ
43	25547033/1	1	PIASTRA	PLATE	PLAQUE	PLATTE
44	12793101/0	4	VITE	SCREW	VIS	SCHRAUBE
45	12583500/0	4	GROWER	GROWER	GROWER	GROWER
46	12523060/0	4	RONDELLA	WASHER	RONDELLE	SCHEIBE
47	25430223/2	1	MOLLA	SPRING	RESSORT	FEDER
48	12789000/0	1	VITE	SCREW	VIS	SCHRAUBE
49	12154330/0	1	DADO	NUT	ECROU	MUTTER
51	25961201/0	1	VOLANTE	STEERING WHEEL	VOLANT	LENKRAD
52	12620299/0	1	SPINA	PIN	COUPLLE	STIFT
53	25120230/0	1	TAPPO	CAP	BOUCHON	STOPFEN
54	27063021/0	1	CAMMA	CAM	CAME	NOCKEN
55	12789100/0	2	VITE	SCREW	VIS	SCHRAUBE
56	12523020/0	2	RONDELLA	WASHER	RONDELLE	SCHEIBE
57	12154330/0	2	DADO	NUT	ECROU	MUTTER
61	25110179/1	1	COPERTURA ROSSO	COVER RED	COUVRE ROUGE	KAPPE ROT
	25110199/1		VERDE	GREEN	VERT	GRÜN
	25110201/1		BLU	BLUE	BLEU	BLAU
62	25600033/0	1	PROTEZIONE DESTRA, NERA	RIGHT GUARD, BLACK	PROTECTION DROITE, NOIR	RECHTE SCHUTZE, SCHWARZ
63	25600034/0	1	PROTEZIONE SINISTRA, NERA	LEFT GUARD, BLACK	PROTECTION GAUCHE, NOIR	LINKE SCHUTZE, SCHWARZ
64	12735402/0	6	VITE	SCREW	VIS	SCHRAUBE
65	12734995/0	2	VITE	SCREW	VIS	SCHRAUBE
66	12735402/0	3	VITE	SCREW	VIS	SCHRAUBE
67	12735402/0	6	VITE	SCREW	VIS	SCHRAUBE
71	25110178/2	1	COPERTURA SACCO ROSSO	SHASS-CATCHER COVER RED	COUVRE-BAC ROUGE	SACKKAPPE ROT
	25110196/1		VERDE	GREEN	VERT	GRÜN
	25110198/1		BLU	BLUE	BLEU	BLAU
72	12729601/1	4	VITE	SCREW	VIS	SCHRAUBE
73	12521331/0	4	RONDELLA	WASHER	RONDELLE	SCHEIBE
81	25600020/0	1	PROTEZIONE SUPERIORE	UPPER GUARD	PROTECTION SUPERIEUR	OBERSCHUTZ
82	25600021/1	1	PROTEZIONE INFERIORE	LOWER GUARD	PROTECTION INFERIEUR	UNTERSCHUTZ
83	12728460/0	2	VITE	SCREW	VIS	SCHRAUBE
84	12521320/0	2	ROSETTA	WASHER	RONDELLE	SCHEIBE
85	12437502/0	2	PIASTRINA	PLATE	PLAQUE	PLÄTTE
91	25735116/1	1	SERBATOIO	TANK	RESERVOIR	TANK
92	25795000/1	1	TAPPO	CAP	BOUCHON	TANKVERSCHLUSS
93	25774258/0	1	SUPPORTO	SUPPORT	SUPPORT	HALTER
94	12735110/0	1	VITE	SCREW	VIS	SCHRAUBE
101	82869011/0	1	PROTEZIONE SILENZIATORE	MUFFLER PROTECTION	PROTECTION SILENCIEUX	AUSPUFFSCHUTZ
102	18566110/0	2	PUNTALE	CAP	BOUCHON	PFRÖPFEN
103	12734995/0	4	VITE	SCREW	VIS	SCHRAUBE
104	25547089/0	1	PIASTRINA DESTRA	RIGHT PLATE	PLAQUE DROITE	RECHTE PLATTE
105	25547091/0	1	PIASTRINA SINISTRA	LEFT PLATE	PLAQUE GAUCHE	LINKE PLATTE
106	12731580/0	4	VITE	SCREW	VIS	SCHRAUBE

J	JP	JT	JR	JTP	JB	JX
92			92 hydro			

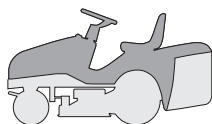

CARROZZERIA
BODY
CARROSSERIE
KARROSSERIE

2004

002a.0

1 / 2

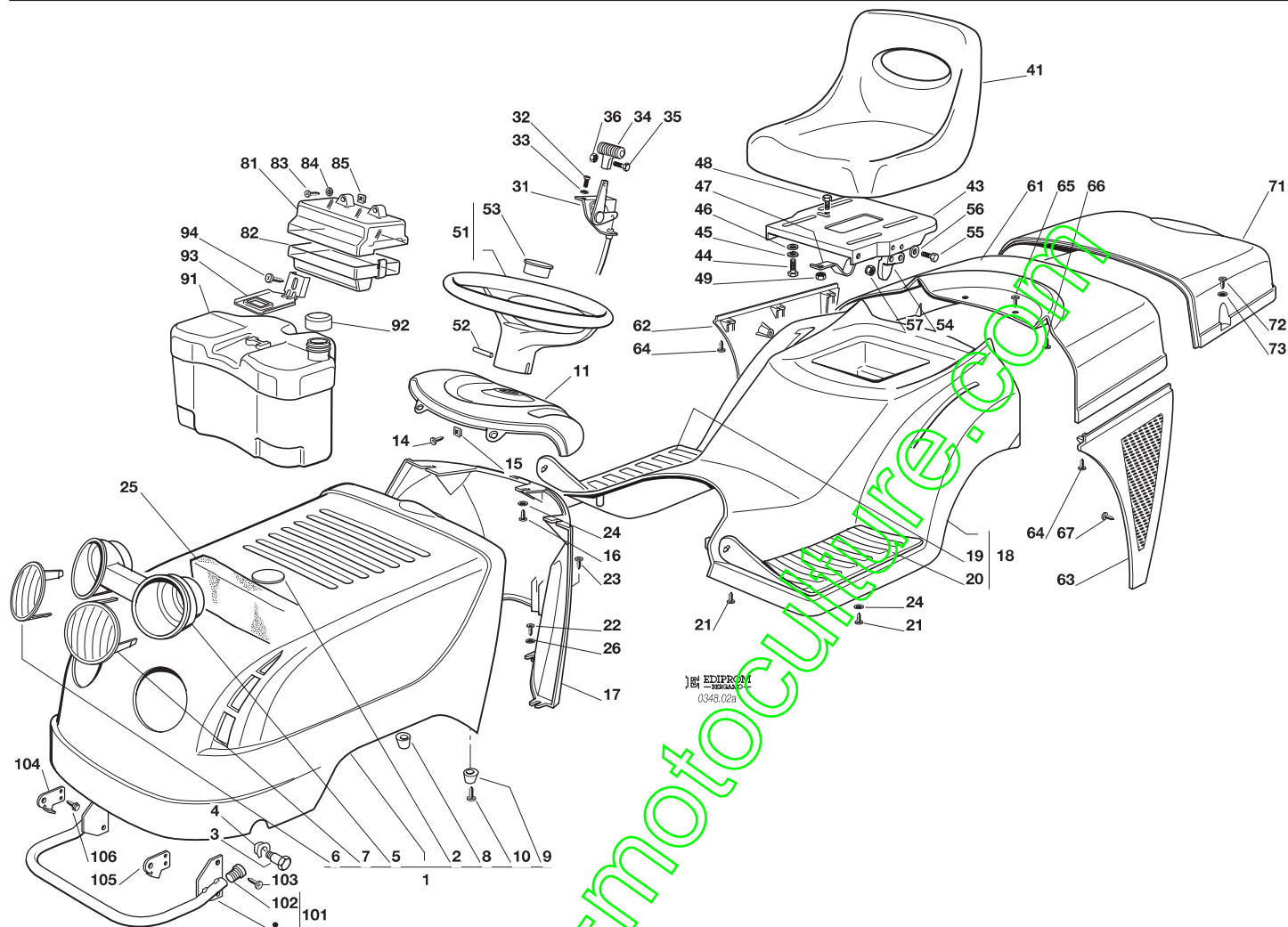

N.	CODE	Q.TY	DESCRIZIONE	DESCRIPTION	DESCRIPTION	BESCHREIBUNG
1	82076897/1	1	COFANO ROSSO	ENGINE HOOD RED	CAPOT ROUGE	HAUBESATZ ROT
	82076898/0		VERDE	GREEN	VERT	GRÜN
	82076932/0		ARANCIONE	ORANGE	ORANGE	DUNKELORANGE
	82076900/0		BLU	BLUE	BLEU	BLAU
2	25547025/1	1	PIASTRINA ROSSA	PLATE RED	PLAQUE ROUGE	PLATTE ROT
	25547026/0		VERDE	GREEN	VERT	GRÜN
	25547144/0		ARANCIONE	ORANGE	ORANGE	DUNKELORANGE
	25547028/0		BLU	BLUE	BLEU	BLAU
3	25510039/0	2	PERNO	PIN	PIVOT	BOLZEN
4	12436050/0	2	PIASTRINA	PLATE	PLAQUE	PLATTE
5	25485002/0	1	PARABOLA FARI	LIGHTS PARABOLA	PARABOLE	SCHWEINWERFERPARABEL
6	25410866/0	1	MASCHERINA DESTRA	RIGHT GRILL	PANNEAU DROITE	RECHTE SCHUTZ
7	25410867/0	1	MASCHERINA SINISTRA	LEFT GRILL	PANNEAU GAUCHE	LINKE SCHUTZ
8	25580012/0	1	PIOLO DESTRO	RIGHT PIN	BONDON DROITE	RECHTE DÜBEL
9	25580013/0	1	PIOLO SINISTRO	LEFT PIN	BONDON GAUCHE	LINKE DÜBEL
10	12727356/0	2	VITE	SCREW	VIS	SCHRAUBE
11	25120164/1	1	CRUSCOTTO	DASHBOARD	TABLEAU COMMANDES	KONSOLE
14	12735110/0	2	VITE	SCREW	VIS	SCHRAUBE
15	12437502/0	2	PIASTRINA	PLATE	PLAQUE	PLATTE
16	12735402/0	3	VITE	SCREW	VIS	SCHRAUBE
17	25785035/3	1	SUPPORTO CRUSCOTTO	DASHBOARD SUPPORT	SUPPORT TABLEAU COMM.	KONSOLEHALTER
18	82110001/3	1	COPERTURA RUOTE ROSSO	WHEELS COVER RED	COUVRE-ROUES ROUGE	RADENKAPPE ROT
	82110002/2		VERDE	GREEN	VERT	GRÜN
	82110015/2		ARANCIONE	ORANGE	ORANGE	DUNKELORANGE
	82110004/2		BLU	BLUE	BLEU	BLAU
18	82110007/3	1	COPERTURA RUOTE (hydro) ROSSO	WHEELS COVER (hydro) RED	COUVRE-ROUES (hydro) ROUGE	RADENKAPPE (hydro) ROT
	82110008/2		VERDE	GREEN	VERT	GRÜN





N.	CODE	Q.TY	DESCRIZIONE	DESCRIPTION	DESCRIPTION	BESCHREIBUNG
	82110016/2		ARANCIONE	ORANGE	ORANGE	DUNKELORANGE
	82110010/2		BLU	BLUE	BLEU	BLAU
19	25110264/1	1	COPRIPEDANA DESTRA	RIGHT FOOTBOARDCOVER	COUVRE MARCHEPIED DRO.	RECHTE FUSSBRETTDECKEL
20	25110263/1	1	COPRIPEDANA SINISTRA	LEFT FOOTBOARD COVER	COUVRE MARCHEPIED GAU.	LINKE FUSSBRETTDECKEL
21	12735410/0	6	VITE	SCREW	VIS	SCHRAUBE
22	12735402/0	4	VITE	SCREW	VIS	SCHRAUBE
23	12728680/0	1	VITE	SCREW	VIS	SCHRAUBE
24	12523040/0	5	ROSETTA	WASHER	RONDELLE	SCHEIBE
25	25730005/1	1	SEPARATORE ASPIRAZ. 13 HP TECUMSEH	INTAKE SEPARATOR 13 HP TECUMSEH	SEPARATEUR ASPIRATIONS 13 HP TECUMSEH	AUGENABSCHIEDER 13 HP TECUMSEH
26	12523050/0	4	ROSETTA	WASHER	RONDELLE	SCHEIBE
31	82000207/0	1	ACCELERATORE	ACCELERATOR	ACCELERATEUR	GAS ZUG
32	12788512/0	2	VITE	SCREW	VIS	SCHRAUBE
33	12581200/0	2	GROWER	GROWER	GROWER	GROWER
34	25394501/0	1	MANOPOLINA	HANDLE	POIGNE	GRIFF
35	12726388/0	1	VITE	SCREW	VIS	SCHRAUBE
36	12290800/0	1	DADO	NUT	ECROU	MUTTER
41	25722453/1	1	SEDILE	SEAT	SIEGE	SITZ
43	25547033/1	1	PIASTRA	PLATE	PLAQUE	PLATTE
44	12793101/0	4	VITE	SCREW	VIS	SCHRAUBE
45	12583500/0	4	GROWER	GROWER	GROWER	GROWER
46	12523060/0	4	RONDELLA	WASHER	RONDELLE	SCHEIBE
47	25430223/2	1	MOLLA	SPRING	RESSORT	FEDER
48	12789000/0	1	VITE	SCREW	VIS	SCHRAUBE
49	12154330/0	1	DADO	NUT	ECROU	MUTTER
51	25961201/0	1	VOLANTE	STEERING WHEEL	VOLANT	LENKRAD
52	12620299/0	1	SPINA	PIN	COUILLON	STIFT
53	25120230/0	1	TAPPO	CAP	BOUCHON	STOPFEN
54	27063021/0	1	CAMMA	CAM	CAME	NOCKEN
55	12789100/0	2	VITE	SCREW	VIS	SCHRAUBE
56	12523020/0	2	RONDELLA	WASHER	RONDELLE	SCHEIBE
57	12154330/0	2	DADO	NUT	ECROU	MUTTER
61	•	1	COPERTURA	COVER	COUVRE	KAPPE
	25110179/1		ROSSO	RED	ROUGE	ROT
	25110199/1		VERDE	GREEN	VERT	GRÜN
	25110127/2		ARANCIONE	ORANGE	ORANGE	DUNKELORANGE
	25110201/1		BLU	BLUE	BLEU	BLAU
62	25600033/0	1	PROTEZIONE DESTRA, NERA	RIGHT GUARD, BLACK	PROTECTION DROITE, NOIR	RECHTE SCHUTZE, SCHWARZ
63	25600034/0	1	PROTEZIONE SINISTRA, NERA	LEFT GUARD, BLACK	PROTECTION GAUCHE, NOIR	LINKE SCHUTZE, SCHWARZ
64	12735402/0	6	VITE	SCREW	VIS	SCHRAUBE
65	12734995/0	2	VITE	SCREW	VIS	SCHRAUBE
66	12735402/0	3	VITE	SCREW	VIS	SCHRAUBE
67	12735402/0	6	VITE	SCREW	VIS	SCHRAUBE
71	•	1	COPERTURA SACCO	GRASS-CATCHER COVER	COUVRE-BAC	SACKKAPPE
	25110178/2		ROSSO	RED	ROUGE	ROT
	25110196/1		VERDE	GREEN	VERT	GRÜN
	25110126/1		ARANCIONE	ORANGE	ORANGE	DUNKELORANGE
	25110198/1		BLU	BLUE	BLEU	BLAU
72	12729601/1	4	VITE	SCREW	VIS	SCHRAUBE
73	12521331/0	4	RONDELLA	WASHER	RONDELLE	SCHEIBE
81	25600020/0	1	PROTEZIONE SUPERIORE	UPPER GUARD	PROTECTION SUPERIEUR	OBERSCHUTZ
82	25600021/1	1	PROTEZIONE INFERIORE	LOWER GUARD	PROTECTION INFERIEUR	UNTERSCHUTZ
83	12728460/0	2	VITE	SCREW	VIS	SCHRAUBE
84	12521320/0	2	ROSETTA	WASHER	RONDELLE	SCHEIBE
85	12437502/0	2	PIASTRINA	PLATE	PLAQUE	PLÄTTE
91	25735116/1	1	SERBATOIO	TANK	RESERVOIR	TANK
92	25795000/1	1	TAPPO	CAP	BOUCHON	TANKVERSCHLUSS
93	25774258/0	1	SUPPORTO	SUPPORT	SUPPORT	HALTER
94	12735110/0	1	VITE	SCREW	VIS	SCHRAUBE
101	82869011/0	1	PROTEZIONE SILENZIATORE	MUFFLER PROTECTION	PROTECTION SILENCIEUX	AUSPUFFSCHUTZ
102	18566110/0	2	PUNTALE	CAP	BOUCHON	PFRÖPFEN
103	12734995/0	4	VITE	SCREW	VIS	SCHRAUBE
104	25547089/0	1	PIASTRINA DESTRA	RIGHT PLATE	PLAQUE DROITE	RECHTE PLATTE
105	25547091/0	1	PIASTRINA SINISTRA	LEFT PLATE	PLAQUE GAUCHE	LINKE PLATTE
106	12731580/0	4	VITE	SCREW	VIS	SCHRAUBE

J

JP

JT

JR

JTP

JB

JX

92

92 hydro

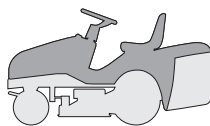

CARROZZERIA
BODY
CARROSSERIE
KARROSSERIE

2004

002b.0

1 / 2

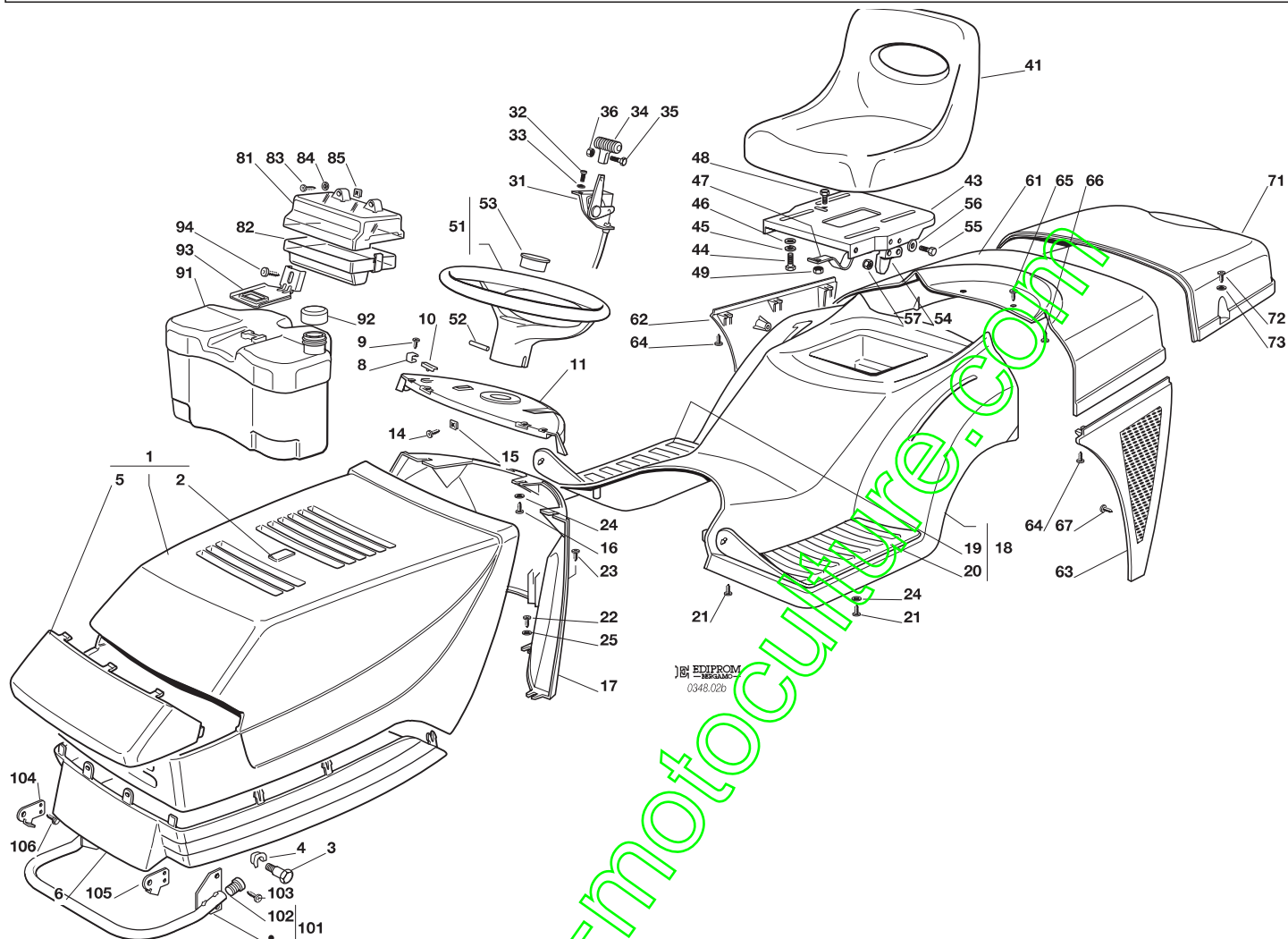

N.	CODE	Q.TY	DESCRIZIONE	DESCRIPTION	DESCRIPTION	BESCHREIBUNG
1	82076802/2	1	COFANO SUPERIORE ROSSO	UPPER ENGINE HOOD RED	CAPOT SUPERIEURE ROUGE	OBERHAUBESATZ ROT
	82076803/0		VERDE	GREEN	VERT	GRÜN
	82076808/0		BLU	BLUE	BLEU	BLAU
2	25547016/2	1	PIASTRINA ROSSA	PLATE RED	PLAQUE ROUGE	PLATTE ROT
	25547015/0		VERDE	GREEN	VERT	GRÜN
	25547024/0		BLU	BLUE	BLEU	BLAU
3	25510023/1	2	PERNO	PIN	PIVOT	BOLZEN
4	12436050/0	2	PIASTRINA	PLATE	PLAQUE	PLATTE
5	25410858/0	1	MASCHERINA	GRILL	PANNEAU	SCHUTZ
6	25076802/0	1	COFANO INFERIORE	LOWER ENGINE HOOD	CAPOT INFERIEURE	UNTERHAUBESATZ
8	25430215/0	2	MOLLA AGGANCI	COUPLING SPRING	RESSORT ACCROCHAGE	KUPPLUNGSFEDER
9	12728450/0	2	VITE	SCREW	VIS	SCHRAUBE
10	25260000/0	2	GOMMINO	GROMMET	PROTECTION	SCHUTZ
11	25120151/0	1	CRUSCOTTO	DASHBOARD	TABLEAU COMMANDES	KONSOLE
14	12735110/0	2	VITE	SCREW	VIS	SCHRAUBE
15	12437502/0	2	PIASTRINA	PLATE	PLAQUE	PLATTE
16	12735402/0	3	VITE	SCREW	VIS	SCHRAUBE
17	25785062/1	1	SUPPORTO CRUSCOTTO	DASHBOARD SUPPORT	SUPPORT TABLEAU COMM.	KONSOLEHALTER
18	82110001/3	1	COPERTURA RUOTE ROSSO	WHEELS COVER RED	COUVRE-ROUES ROUGE	RADENKAPPE ROT
	82110002/2		VERDE	GREEN	VERT	GRÜN
	82110004/2		BLU	BLUE	BLEU	BLAU
18	82110007/3	1	COPERTURA RUOTE (hydro) ROSSO	WHEELS COVER (hydro) RED	COUVRE-ROUES (hydro) ROUGE	RADENKAPPE (hydro) ROT
	82110008/2		VERDE	GREEN	VERT	GRÜN
	82110010/2		BLU	BLUE	BLEU	BLAU
19	25110264/1	1	COPRIPEDANA DESTRA	RIGHT FOOTBOARDCOVER	COUVRE MARCHEPIED DRO.	RECHTE FUSSBRETTDECKEL
20	25110263/1	1	COPRIPEDANA SINISTRA	LEFT FOOTBOARD COVER	COUVRE MARCHEPIED GAU.	LINKE FUSSBRETTDECKEL
21	12735410/0	6	VITE	SCREW	VIS	SCHRAUBE





N.	CODE	Q.TY	DESCRIZIONE	DESCRIPTION	DESCRIPTION	BESCHREIBUNG
22	12735402/0	4	VITE	SCREW	VIS	SCHRAUBE
23	12728680/0	1	VITE	SCREW	VIS	SCHRAUBE
24	12523040/0	5	ROSETTA	WASHER	RONDELLE	SCHEIBE
25	12523050/0	4	ROSETTA	WASHER	RONDELLE	SCHEIBE
31	82000207/0	1	ACCELERATORE	ACCELERATOR	ACCELERATEUR	GAS ZUG
32	12788512/0	2	VITE	SCREW	VIS	SCHRAUBE
33	12581200/0	2	GROWER	GROWER	GROWER	GROWER
34	25394501/0	1	MANOPOLINA	HANDLE	POIGNE	GRIFF
35	12726388/0	1	VITE	SCREW	VIS	SCHRAUBE
36	12290800/0	1	DADO	NUT	ECROU	MUTTER
41	25722453/1	1	SEDILE	SEAT	SIEGE	SITZ
43	25547033/1	1	PIASTRA	PLATE	PLAQUE	PLATTE
44	12793101/0	4	VITE	SCREW	VIS	SCHRAUBE
45	12583500/0	4	GROWER	GROWER	GROWER	GROWER
46	12523060/0	4	RONDELLA	WASHER	RONDELLE	SCHEIBE
47	25430223/2	1	MOLLA	SPRING	RESSORT	FEDER
48	12789000/0	1	VITE	SCREW	VIS	SCHRAUBE
49	12154330/0	1	DADO	NUT	ECROU	MUTTER
51	25961201/0	1	VOLANTE	STEERING WHEEL	VOLANT	LENKRAD
52	12620299/0	1	SPINA	PIN	GOUPILLE	STIFT
53	25120230/0	1	TAPPO	CAP	BOUCHON	STOPFEN
54	27063021/0	1	CAMMA	CAM	CAME	NOCKEN
55	12789100/0	2	VITE	SCREW	VIS	SCHRAUBE
56	12523020/0	2	RONDELLA	WASHER	RONDELLE	SCHEIBE
57	12154330/0	2	DADO	NUT	ECROU	MUTTER
61	•	1	COPERTURA	COVER	COUVRE	KAPPE
	25110179/1		ROSSO	RED	ROUGE	ROT
	25110199/1		VERDE	GREEN	VERT	GRÜN
	25110201/1		BLU	BLUE	BLEU	BLAU
62	25600033/0	1	PROTEZIONE DESTRA, NERA	RIGHT GUARD, BLACK	PROTECTION DROITE, NOIR	RECHTE SCHUTZE, SCHWARZ
63	25600034/0	1	PROTEZIONE SINISTRA, NERA	LEFT GUARD, BLACK	PROTECTION GAUCHE, NOIR	LINKE SCHUTZE, SCHWARZ
64	12735402/0	6	VITE	SCREW	VIS	SCHRAUBE
65	12734995/0	2	VITE	SCREW	VIS	SCHRAUBE
66	12735402/0	3	VITE	SCREW	VIS	SCHRAUBE
67	12735402/0	6	VITE	SCREW	VIS	SCHRAUBE
71	•	1	COPERTURA SACCO	GRASS-CATCHER COVER	COUVRE-BAC	SACKKAPPE
	25110178/2		ROSSO	RED	ROUGE	ROT
	25110196/1		VERDE	GREEN	VERT	GRÜN
	25110198/1		BLU	BLUE	BLEU	BLAU
72	12729601/1	4	VITE	SCREW	VIS	SCHRAUBE
73	12521331/0	4	RONDELLA	WASHER	RONDELLE	SCHEIBE
81	25600020/0	1	PROTEZIONE SUPERIORE	UPPER GUARD	PROTECTION SUPERIEUR	OBERSCHUTZ
82	25600021/1	1	PROTEZIONE INFERIORE	LOWER GUARD	PROTECTION INFERIEUR	UNTERSCHUTZ
83	12728460/0	2	VITE	SCREW	VIS	SCHRAUBE
84	12521320/0	2	ROSETTA	WASHER	RONDELLE	SCHEIBE
85	12437502/0	2	PIASTRINA	PLATE	PLAQUE	PLÄTTE
91	25735116/1	1	SERBATOIO	TANK	RESERVOIR	TANK
92	25795000/1	1	TAPPO	CAP	BOUCHON	TANKVERSCHLUSS
93	25774258/0	1	SUPPORTO	SUPPORT	SUPPORT	HALTER
94	12735110/0	1	VITE	SCREW	VIS	SCHRAUBE
101	82869011/0	1	PROTEZIONE SILENZIATORE	MUFFLER PROTECTION	PROTECTION SILENCIEUX	AUSPUFFSCHUTZ
102	18566110/0	2	PUNTALE	CAP	BOUCHON	PFRÖPFEN
103	12734995/0	4	VITE	SCREW	VIS	SCHRAUBE
104	25547089/0	1	PIASTRINA DESTRA	RIGHT PLATE	PLAQUE DROITE	RECHTE PLATTE
105	25547091/0	1	PIASTRINA SINISTRA	LEFT PLATE	PLAQUE GAUCHE	LINKE PLATTE
106	12731580/0	4	VITE	SCREW	VIS	SCHRAUBE

J JP JT JR JTP JB JX

92

92 hydro

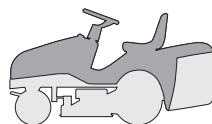

CARROZZERIA
BODY
CARROSSERIE
KARROSSERIE

2004

002c.0

1 / 2

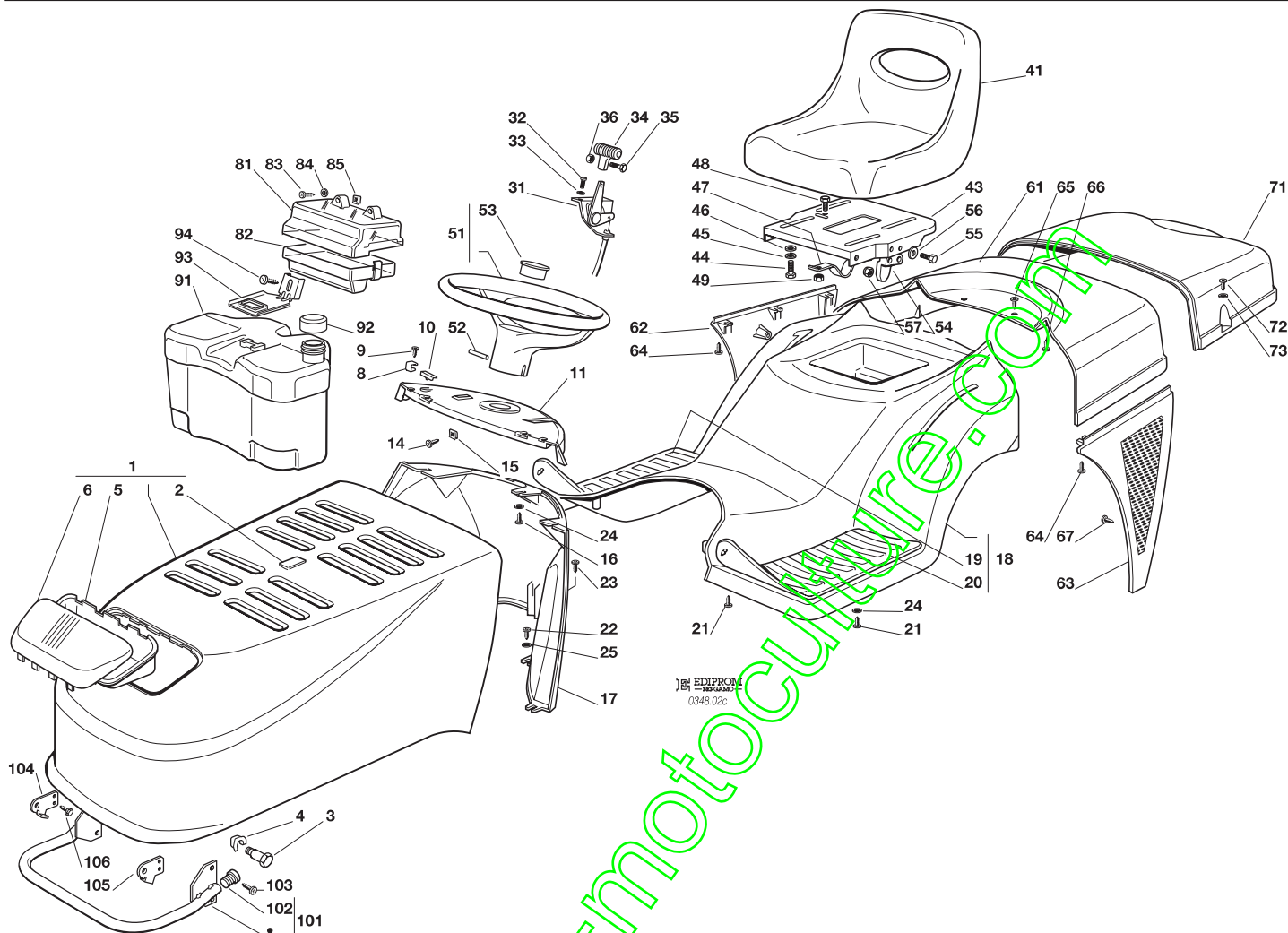

N.	CODE	Q.TY	DESCRIZIONE	DESCRIPTION	DESCRIPTION	BESCHREIBUNG
1	82076817/2	1	COFANO ROSSO	ENGINE HOOD RED	CAPOT ROUGE	HAUBESATZ ROT
	82076818/1		VERDE	GREEN	VERT	GRÜN
2	25547016/2	1	PIASTRINA ROSSA	PLATE RED	PLAQUE ROUGE	PLATTE ROT
	25547015/0		VERDE	GREEN	VERT	GRÜN
3	25510039/0	2	PERNO	PIN	PIVOT	BOLZEN
4	12436050/0	2	PIASTRINA	PLATE	PLAQUE	PLATTE
5	25485001/0	1	PARABOLA FARI	LIGHTS PARABOLA	PARABOLE	SCHEINWERFERPARABEL
6	25410865/0	1	MASCHERINA	GRILL	PANNEAU	SCHUTZ
8	25430215/0	2	MOLLA AGGANCI	COUPLING SPRING	RESSORT ACCROCHAGE	KUPPLUNGSFEDER
9	12728450/0	2	VITE	SCREW	VIS	SCHRAUBE
10	25260000/0	2	GOMMINO	GROMMET	PROTECTION	SCHUTZ
11	25120151/0	1	CRUSCOTTO	DASHBOARD	TABLEAU COMMANDES	KONSOLE
14	12735110/0	2	VITE	SCREW	VIS	SCHRAUBE
15	12437502/0	2	PIASTRINA	PLATE	PLAQUE	PLATTE
16	12735402/0	3	VITE	SCREW	VIS	SCHRAUBE
17	25785062/1	1	SUPPORTO CRUSCOTTO	DASHBOARD SUPPORT	SUPPORT TABLEAU COMM.	KONSOLEHALTER
18	82110001/3	1	COPERTURA RUOTE ROSSO	WHEELS COVER RED	COUVRE-ROUES ROUGE	RADENKAPPE ROT
	82110002/2		VERDE	GREEN	VERT	GRÜN
18	82110007/3	1	COPERTURA RUOTE (hydro) ROSSO	WHEELS COVER (hydro) RED	COUVRE-ROUES (hydro) ROUGE	RADENKAPPE (hydro) ROT
	82110008/2		VERDE	GREEN	VERT	GRÜN
19	25110264/1	1	COPRIPEDANA DESTRA	RIGHT FOOTBOARDCOVER	COUVRE MARCHEPIED DRO.	RECHTE FUSSBRETTDECKEL
20	25110263/1	1	COPRIPEDANA SINISTRA	LEFT FOOTBOARD COVER	COUVRE MARCHEPIED GAU.	LINKE FUSSBRETTDECKEL
21	12735410/0	6	VITE	SCREW	VIS	SCHRAUBE
22	12735402/0	4	VITE	SCREW	VIS	SCHRAUBE
23	12728680/0	1	VITE	SCREW	VIS	SCHRAUBE
24	12523040/0	5	ROSETTA	WASHER	RONDELLE	SCHEIBE
25	12523050/0	4	ROSETTA	WASHER	RONDELLE	SCHEIBE





N.	CODE	Q.TY	DESCRIZIONE	DESCRIPTION	DESCRIPTION	BESCHREIBUNG
31	82000207/0	1	ACCELERATORE	ACCELERATOR	ACCELERATEUR	GAS ZUG
32	12788512/0	2	VITE	SCREW	VIS	SCHRAUBE
33	12581200/0	2	GROWER	GROWER	GROWER	GROWER
34	25394501/0	1	MANOPOLINA	HANDLE	POIGNE	GRIFF
35	12726388/0	1	VITE	SCREW	VIS	SCHRAUBE
36	12290800/0	1	DADO	NUT	ECROU	MUTTER
41	25722453/1	1	SEDILE	SEAT	SIEGE	SITZ
43	25547033/1	1	PIASTRA	PLATE	PLAQUE	PLATTE
44	12793101/0	4	VITE	SCREW	VIS	SCHRAUBE
45	12583500/0	4	GROWER	GROWER	GROWER	GROWER
46	12523060/0	4	RONDELLA	WASHER	RONDELLE	SCHEIBE
47	25430223/2	1	MOLLA	SPRING	RESSORT	FEDER
48	12789000/0	1	VITE	SCREW	VIS	SCHRAUBE
49	12154330/0	1	DADO	NUT	ECROU	MUTTER
51	25961201/0	1	VOLANTE	STEERING WHEEL	VOLANT	LENKRAD
52	12620299/0	1	SPINA	PIN	GOUPILLE	STIFT
53	25120230/0	1	TAPPO	CAP	BOUCHON	STOPFEN
54	27063021/0	1	CAMMA	CAM	CAME	NOCKEN
55	12789100/0	2	VITE	SCREW	VIS	SCHRAUBE
56	12523020/0	2	RONDELLA	WASHER	RONDELLE	SCHEIBE
57	12154330/0	2	DADO	NUT	ECROU	MUTTER
61	25110179/1	1	COPERTURA ROSSO	COVER RED	COUVRE ROUGE	KAPPE ROT
	25110199/1		VERDE	GREEN	VERT	GRÜN
62	25600033/0	1	PROTEZIONE DESTRA, NERA	RIGHT GUARD, BLACK	PROTECTION DROITE, NOIR	RECHTE SCHUTZE, SCHWARZ
63	25600034/0	1	PROTEZIONE SINISTRA, NERA	LEFT GUARD, BLACK	PROTECTION GAUCHE, NOIR	LINKE SCHUTZE, SCHWARZ
64	12735402/0	6	VITE	SCREW	VIS	SCHRAUBE
65	12734995/0	2	VITE	SCREW	VIS	SCHRAUBE
66	12735402/0	3	VITE	SCREW	VIS	SCHRAUBE
67	12735402/0	6	VITE	SCREW	VIS	SCHRAUBE
71	25110178/2	1	COPERTURA SACCO ROSSO	GRASS CATCHER COVER RED	COUVRE-BAC ROUGE	SACKKAPPE ROT
	25110196/1		VERDE	GREEN	VERT	GRÜN
72	12729601/1	4	VITE	SCREW	VIS	SCHRAUBE
73	12521331/0	4	RONDELLA	WASHER	RONDELLE	SCHEIBE
81	25600020/0	1	PROTEZIONE SUPERIORE	UPPER GUARD	PROTECTION SUPERIEUR	OBERSCHUTZ
82	25600021/1	1	PROTEZIONE INFERIORE	LOWER GUARD	PROTECTION INFERIEUR	UNTERSCHUTZ
83	12728460/0	2	VITE	SCREW	VIS	SCHRAUBE
84	12521320/0	2	ROSETTA	WASHER	RONDELLE	SCHEIBE
85	12437502/0	2	PIASTRINA	PLATE	PLAQUE	PLÄTTE
91	25735116/1	1	SERBATOIO	TANK	RESERVOIR	TANK
92	25795000/1	1	TAPPO	CAP	BOUCHON	TANKVERSCHLUSS
93	25774258/0	1	SUPPORTO	SUPPORT	SUPPORT	HALTER
94	12735110/0	1	VITE	SCREW	VIS	SCHRAUBE
101	82869011/0	1	PROTEZIONE SILENZIATORE	MUFFLER PROTECTION	PROTECTION SILENCIEUX	AUSPUFFSCHUTZ
102	18566110/0	2	PUNTALE	CAP	BOUCHON	PFRÖPFEN
103	12734995/0	4	VITE	SCREW	VIS	SCHRAUBE
104	25547089/0	1	PIASTRINA DESTRA	RIGHT PLATE	PLAQUE DROITE	RECHTE PLATTE
105	25547091/0	1	PIASTRINA SINISTRA	LEFT PLATE	PLAQUE GAUCHE	LINKE PLATTE
106	12731580/0	4	VITE	SCREW	VIS	SCHRAUBE

J	JP	JT	JR	JTP	JB	JX
92				92 hydro		

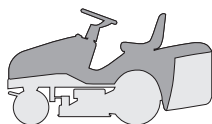

**CARROZZERIA
BODY
CARROSSERIE
KARROSSERIE**

2004

002d.0

1 / 2

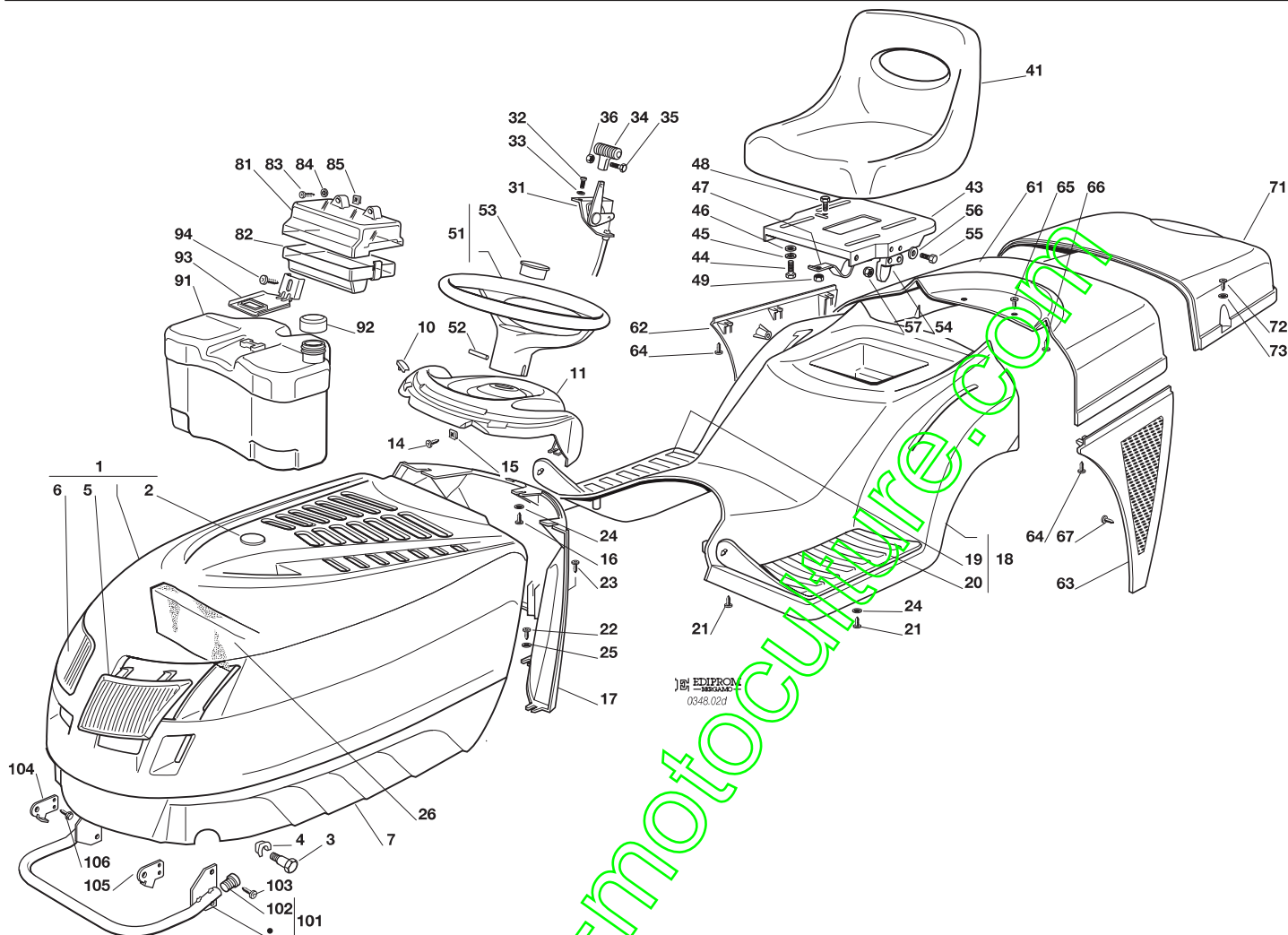

N.	CODE	Q.TY	DESCRIZIONE	DESCRIPTION	DESCRIPTION	BESCHREIBUNG
1	82076841/2	1	COFANO SUPERIORE ROSSO	UPPER ENGINE HOOD RED	CAPOT SUPERIEURE ROUGE	OBERHAUBESATZ ROT
	82076843/1		VERDE	GREEN	VERT	GRÜN
	82076847/1		BLU	BLUE	BLEU	BLAU
2	25547025/1	1	PIASTRINA ROSSA	PLATE RED	PLAQUE ROUGE	PLATTE ROT
	25547026/0		VERDE	GREEN	VERT	GRÜN
	25547028/0		BLU	BLUE	BLEU	BLAU
3	25510023/1	2	PERNO	PIN	PIVOT	BOLZEN
4	12436050/0	2	PIASTRINA	PLATE	PLAQUE	PLATTE
5	25410861/0	1	MASCHERINA SINISTRA	LEFT GRILL	PANNEAU GAUCHE	LINKE SCHUTZ
6	25410860/0	1	MASCHERINA DESTRA	RIGHT GRILL	PANNEAU DROITE	RECHTE SCHUTZ
7	25076808/0	1	COFANO INFERIORE	LOWER ENGINE HOOD	CAPOT INFERIEURE	UNTERHAUBESATZ
10	25260000/0	2	GOMMINGO	GROMMET	PROTECTION	SCHUTZ
11	25120179/0	1	CRUSCOTTO	DASHBOARD	TABLEAU COMMANDES	KONSOLE
14	12735110/0	2	VITE	SCREW	VIS	SCHRAUBE
15	12437502/0	2	PIASTRINA	PLATE	PLAQUE	PLATTE
16	12735402/0	3	VITE	SCREW	VIS	SCHRAUBE
17	25785053/1	1	SUPPORTO CRUSCOTTO	DASHBOARD SUPPORT	SUPPORT TABLEAU COMM.	KONSOLEHALTER
18	82110001/3	1	COPERTURA RUOTE ROSSO	WHEELS COVER RED	COUVRE-ROUES ROUGE	RADENKAPPE ROT
	82110002/2		VERDE	GREEN	VERT	GRÜN
	82110004/2		BLU	BLUE	BLEU	BLAU
18	82110007/3	1	COPERTURA RUOTE (hydro) ROSSO	WHEELS COVER (hydro) RED	COUVRE-ROUES (hydro) ROUGE	RADENKAPPE (hydro) ROT
	82110008/2		VERDE	GREEN	VERT	GRÜN
	82110010/2		BLU	BLUE	BLEU	BLAU
19	25110264/1	1	COPRIPEDANA DESTRA	RIGHT FOOTBOARDCOVER	COUVRE MARCHEPIED DRO.	RECHTE FUSSBRETTDECKEL
20	25110263/1	1	COPRIPEDANA SINISTRA	LEFT FOOTBOARD COVER	COUVRE MARCHEPIED GAU.	LINKE FUSSBRETTDECKEL
21	12735410/0	6	VITE	SCREW	VIS	SCHRAUBE
22	12735402/0	4	VITE	SCREW	VIS	SCHRAUBE





N.	CODE	Q.TY	DESCRIZIONE	DESCRIPTION	DESCRIPTION	BESCHREIBUNG
23	12728680/0	1	VITE	SCREW	VIS	SCHRAUBE
24	12523040/0	5	ROSETTA	WASHER	RONDELLE	SCHEIBE
25	12523050/0	4	ROSETTA	WASHER	RONDELLE	SCHEIBE
26	25730012/0	1	SEPARATORE ASPIRAZIONE	INTAKE SEPARATOR	SEPARATEUR ASPIRATIONS	AUGENABSCHIEDER
31	82000207/0	1	ACCELERATORE	ACCELERATOR	ACCELERATEUR	GAS ZUG
32	12788512/0	2	VITE	SCREW	VIS	SCHRAUBE
33	12581200/0	2	GROWER	GROWER	GROWER	GROWER
34	25394501/0	1	MANOPOLINA	HANDLE	POIGNE	GRIFF
35	12726388/0	1	VITE	SCREW	VIS	SCHRAUBE
36	12290800/0	1	DADO	NUT	ECROU	MUTTER
41	25722453/1	1	SEDILE	SEAT	SIEGE	SITZ
43	25547033/1	1	PIASTRA	PLATE	PLAQUE	PLATTE
44	12793101/0	4	VITE	SCREW	VIS	SCHRAUBE
45	12583500/0	4	GROWER	GROWER	GROWER	GROWER
46	12523060/0	4	RONDELLA	WASHER	RONDELLE	SCHEIBE
47	25430223/2	1	MOLLA	SPRING	RESSORT	FEDER
48	12789000/0	1	VITE	SCREW	VIS	SCHRAUBE
49	12154330/0	1	DADO	NUT	ECROU	MUTTER
51	25961201/0	1	VOLANTE	STEERING WHEEL	VOYANT	LENKRAD
52	12620299/0	1	SPINA	PIN	COUPLLE	STIFT
53	25120230/0	1	TAPPO	CAP	BOUCHON	STOPFEN
54	27063021/0	1	CAMMA	CAM	CAME	NOCKEN
55	12789100/0	2	VITE	SCREW	VIS	SCHRAUBE
56	12523020/0	2	RONDELLA	WASHER	RONDELLE	SCHEIBE
57	12154330/0	2	DADO	NUT	ECROU	MUTTER
61	25110179/1	1	COPERTURA ROSSO	COVER RED	COUVRE ROUGE	KAPPE ROT
	25110199/1		VERDE	GREEN	VERT	GRÜN
	25110201/1		BLU	BLUE	BLEU	BLAU
62	25600033/0	1	PROTEZIONE DESTRA, NERA	RIGHT GUARD, BLACK	PROTECTION DROITE, NOIR	RECHTE SCHUTZE, SCHWARZ
63	25600034/0	1	PROTEZIONE SINISTRA, NERA	LEFT GUARD, BLACK	PROTECTION GAUCHE, NOIR	LINKE SCHUTZE, SCHWARZ
64	12735402/0	6	VITE	SCREW	VIS	SCHRAUBE
65	12734995/0	2	VITE	SCREW	VIS	SCHRAUBE
66	12735402/0	3	VITE	SCREW	VIS	SCHRAUBE
67	12735402/0	6	VITE	SCREW	VIS	SCHRAUBE
71	25110178/2	1	COPERTURA SACCO ROSSO	SHASS-CATCHER COVER RED	COUVRE-BAC ROUGE	SACKKAPPE ROT
	25110196/1		VERDE	GREEN	VERT	GRÜN
	25110198/1		BLU	BLUE	BLEU	BLAU
72	12729601/1	4	VITE	SCREW	VIS	SCHRAUBE
73	12521331/0	4	RONDELLA	WASHER	RONDELLE	SCHEIBE
81	25600020/0	1	PROTEZIONE SUPERIORE	UPPER GUARD	PROTECTION SUPERIEUR	OBERSCHUTZ
82	25600021/1	1	PROTEZIONE INFERIORE	LOWER GUARD	PROTECTION INFERIEUR	UNTERSCHUTZ
83	12728460/0	2	VITE	SCREW	VIS	SCHRAUBE
84	12521320/0	2	ROSETTA	WASHER	RONDELLE	SCHEIBE
85	12437502/0	2	PIASTRINA	PLATE	PLAQUE	PLÄTTE
91	25735116/1	1	SERBATOIO	TANK	RESERVOIR	TANK
92	25795000/1	1	TAPPO	CAP	BOUCHON	TANKVERSCHLUSS
93	25774258/0	1	SUPPORTO	SUPPORT	SUPPORT	HALTER
94	12735110/0	1	VITE	SCREW	VIS	SCHRAUBE
101	82869006/1	1	PROTEZIONE SILENZIATORE	MUFFLER PROTECTION	PROTECTION SILENCIEUX	AUSPUFFSCHUTZ
102	18566110/0	2	PUNTALE	CAP	BOUCHON	PFRÖPFEN
103	12734995/0	4	VITE	SCREW	VIS	SCHRAUBE
104	25547089/0	1	PIASTRINA DESTRA	RIGHT PLATE	PLAQUE DROITE	RECHTE PLATTE
105	25547091/0	1	PIASTRINA SINISTRA	LEFT PLATE	PLAQUE GAUCHE	LINKE PLATTE
106	12731580/0	4	VITE	SCREW	VIS	SCHRAUBE

J	JP	JT	JR	JTP	JB	JX
92				92 hydro		

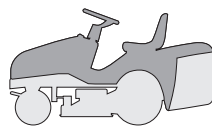

**CARROZZERIA
BODY
CARROSSERIE
KARROSSERIE**

2004

002e.0

1 / 2

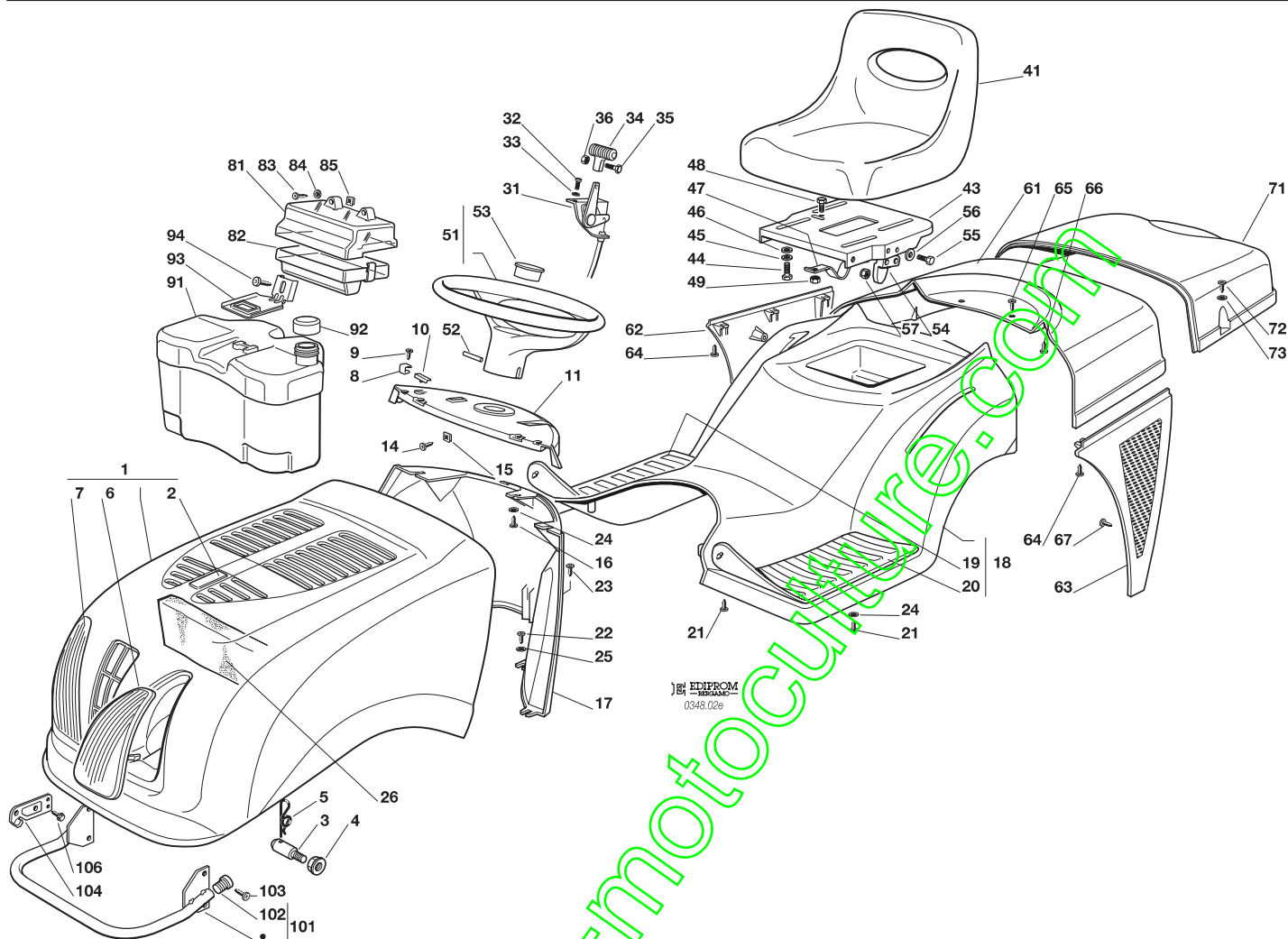

N.	CODE	Q.TY	DESCRIZIONE	DESCRIPTION	DESCRIPTION	BESCHREIBUNG
1	82076917/1	1	COFANO ROSSO	ENGINE HOOD RED	CAPOT ROUGE	HAUBESATZ ROT
	82076918/0		VERDE	GREEN	VERT	GRÜN
	82076919/0		BLU	BLUE	BLEU	BLAU
2	25547016/2	1	PIASTRINA ROSSA	PLATE RED	PLAQUE ROUGE	PLATTE ROT
	25547015/0		VERDE	GREEN	VERT	GRÜN
	25547024/0		BLU	BLUE	BLEU	BLAU
3	25510068/0	2	PERNO	PIN	PIVOT	BOLZEN
4	12293201/0	2	DADO	NUT	ECROU	MUTTER
5	24487998/0	1	COPPIGLIA	COTTER PIN	GOUILLE	SPLIT
6	25410869/0	1	MASCHERINA SINISTRA	LEFT GRILL	PANNEAU GAUCHE	LINKE SCHUTZ
7	25410868/0	1	MASCHERINA DESTRA	RIGHT GRILL	PANNEAU DROITE	RECHTE SCHUTZ
8	25430215/0	2	MOLLA AGGANCIO	COUPLING SPRING	RESSORT ACCROCHAGE	KUPPLUNGSFEDER
9	12728450/0	2	VITE	SCREW	VIS	SCHRAUBE
10	25260000/0	2	GOMMINO	GROMMET	PROTECTION	SCHUTZ
11	25120151/0	1	CRUSCOTTO	DASHBOARD	TABEUAU COMMANDES	KONSOLE
14	12735110/0	2	VITE	SCREW	VIS	SCHRAUBE
15	12437502/0	2	PIASTRINA	PLATE	PLAQUE	PLATTE
16	12735402/0	3	VITE	SCREW	VIS	SCHRAUBE
17	25785053/1	1	SUPPORTO CRUSCOTTO	DASHBOARD SUPPORT	SUPPORT TABLEAU COMM.	KONSOLEHALTER
18	82110001/3	1	COPERTURA RUOTE ROSSO	WHEELS COVER RED	COUVRE-ROUES ROUGE	RADENKAPPE ROT
	82110002/2		VERDE	GREEN	VERT	GRÜN
	82110004/2		BLU	BLUE	BLEU	BLAU
18	82110007/3	1	COPERTURA RUOTE (hydro) ROSSO	WHEELS COVER (hydro) RED	COUVRE-ROUES (hydro) ROUGE	RADENKAPPE (hydro) ROT
	82110008/2		VERDE	GREEN	VERT	GRÜN
	82110010/2		BLU	BLUE	BLEU	BLAU
19	25110264/1	1	COPRIPEDANA DESTRA	RIGHT FOOTBOARDCOVER	COUVRE MARCHEPIED DRO.	RECHTE FUSSBRETTDECKEL
20	25110263/1	1	COPRIPEDANA SINISTRA	LEFT FOOTBOARD COVER	COUVRE MARCHEPIED GAU.	LINKE FUSSBRETTDECKEL





N.	CODE	Q.TY	DESCRIZIONE	DESCRIPTION	DESCRIPTION	BESCHREIBUNG
21	12735410/0	6	VITE	SCREW	VIS	SCHRAUBE
22	12735402/0	4	VITE	SCREW	VIS	SCHRAUBE
23	12728680/0	1	VITE	SCREW	VIS	SCHRAUBE
24	12523040/0	5	ROSETTA	WASHER	RONDELLE	SCHEIBE
25	12523050/0	4	ROSETTA	WASHER	RONDELLE	SCHEIBE
26	25730014/0	1	SEPARATORE ASPIRAZIONE 12,5 ÷ 15,5 HP B&S	INTAKE SEPARATOR 12,5 ÷ 15,5 HP B&S	SEPARATEUR ASPIRATIONS 12,5 ÷ 15,5 HP B&S	AUGENABSCHIEDER 12,5 ÷ 15,5 HP B&S
31	82000207/0	1	ACCELERATORE	ACCELERATOR	ACCELERATEUR	GAS ZUG
32	12788512/0	2	VITE	SCREW	VIS	SCHRAUBE
33	12581200/0	2	GROWER	GROWER	GROWER	GROWER
34	25394501/0	1	MANOPOLINA	HANDLE	POIGNE	GRIFF
35	12726388/0	1	VITE	SCREW	VIS	SCHRAUBE
36	12290800/0	1	DADO	NUT	ECROU	MUTTER
41	25722453/1	1	SEDILE	SEAT	SIEGE	SITZ
43	25547033/1	1	PIASTRA	PLATE	PLAQUE	PLATTE
44	12793101/0	4	VITE	SCREW	VIS	SCHRAUBE
45	12583500/0	4	GROWER	GROWER	GROWER	GROWER
46	12523060/0	4	RONDELLA	WASHER	RONDELLE	SCHEIBE
47	25430223/2	1	MOLLA	SPRING	RESSORT	FEDER
48	12789000/0	1	VITE	SCREW	VIS	SCHRAUBE
49	12154330/0	1	DADO	NUT	ECROU	MUTTER
51	25961201/0	1	VOLANTE	STEERING WHEEL	VOLANT	LENKRAD
52	12620299/0	1	SPINA	PIN	COUILLÉ	STIFT
53	25120230/0	1	TAPPO	CAP	BOUCHON	STOPFEN
54	27063021/0	1	CAMMA	CAM	CAME	NOCKEN
55	12789100/0	2	VITE	SCREW	VIS	SCHRAUBE
56	12523020/0	2	RONDELLA	WASHER	RONDELLE	SCHEIBE
57	12154330/0	2	DADO	NUT	ECROU	MUTTER
61	☛	1	COPERTURA	COVER	COUVRE	KAPPE
	25110179/1		ROSSO	RED	ROUGE	ROT
	25110199/1		VERDE	GREEN	VERT	GRÜN
	25110201/1		BLU	BLUE	BLEU	BLAU
62	25600033/0	1	PROTEZIONE DESTRA, NERA	RIGHT GUARD, BLACK	PROTECTION DROITE, NOIR	RECHTE SCHUTZE, SCHWARZ
63	25600034/0	1	PROTEZIONE SINISTRA, NERA	LEFT GUARD, BLACK	PROTECTION GAUCHE, NOIR	LINKE SCHUTZE, SCHWARZ
64	12735402/0	6	VITE	SCREW	VIS	SCHRAUBE
65	12734995/0	2	VITE	SCREW	VIS	SCHRAUBE
66	12735402/0	3	VITE	SCREW	VIS	SCHRAUBE
67	12735402/0	6	VITE	SCREW	VIS	SCHRAUBE
71	☛	1	COPERTURA SACCO	GRASS-CATCHER COVER	COUVRE-BAC	SACKKAPPE
	25110178/2		ROSSO	RED	ROUGE	ROT
	25110196/1		VERDE	GREEN	VERT	GRÜN
	25110198/1		BLU	BLUE	BLEU	BLAU
72	12729601/1	4	VITE	SCREW	VIS	SCHRAUBE
73	12521331/0	4	RONDELLA	WASHER	RONDELLE	SCHEIBE
81	25600020/0	1	PROTEZIONE SUPERIORE	UPPER GUARD	PROTECTION SUPERIEUR	OBERSCHUTZ
82	25600021/1	1	PROTEZIONE INFERIORE	LOWER GUARD	PROTECTION INFERIEUR	UNTERSCHUTZ
83	12728460/0	2	VITE	SCREW	VIS	SCHRAUBE
84	12521320/0	2	ROSETTA	WASHER	RONDELLE	SCHEIBE
85	12437502/0	2	PIASTRINA	PLATE	PLAQUE	PLÄTTE
91	25735116/1	1	SERBATOIO	TANK	RESERVOIR	TANK
92	25795000/1	1	TAPPO	CAP	BOUCHON	TANKVERSCHLUSS
93	25774258/0	1	SUPPORTO	SUPPORT	SUPPORT	HALTER
94	12735110/0	1	VITE	SCREW	VIS	SCHRAUBE
101	82869011/0	1	PROTEZIONE SILENZIATORE	MUFFLER PROTECTION	PROTECTION SILENCIEUX	AUSPUFFSCHUTZ
102	18566110/0	2	PUNTALE	CAP	BOUCHON	PFRÖPFEN
103	12734995/0	4	VITE	SCREW	VIS	SCHRAUBE
104	25547109/1	2	PIASTRINA	PLATE	PLAQUE	PLATTE
106	12731580/0	4	VITE	SCREW	VIS	SCHRAUBE

J JP JT JR JTP JB JX

92

92 hydro

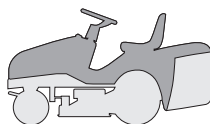

CARROZZERIA
BODY
CARROSSERIE
KARROSSERIE

2004

002f.0

1 / 2

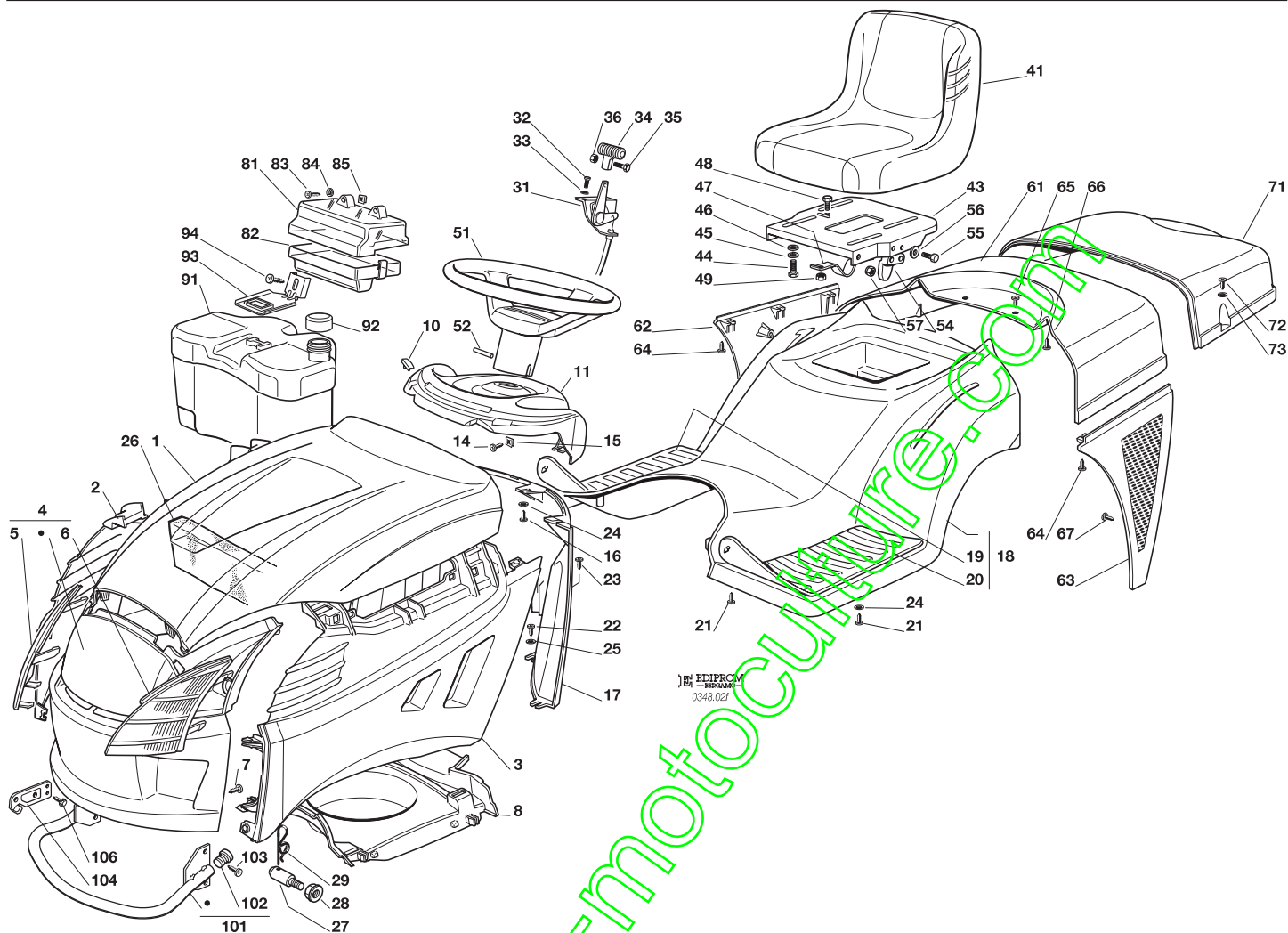

N.	CODE	Q.TY	DESCRIZIONE	DESCRIPTION	DESCRIPTION	BESCHREIBUNG
1	25076858/0	1	COFANO SUPERIORE	UPPER ENGINE HOOD	CAPOT SUPERIEURE	OBERHAUBESATZ
2	25207120/0	1	COFANO DX	HOOD, RIGHT	CAPOT DROITE	RECHTE HAUBE
3	25207124/0	1	COFANO SX	HOOD, LEFT	CAPOT GAUCHE	LINKE HAUBE
4	82394607/0	1	COFANO FRONTALE	HOOD, FRONT	CAPOT AVANT	VORDE HAUBE
5	25410874/0	1	MASCHERINA DESTRA	RIGHT GRILL	PANNEAU DROITE	RECHTE SCHUTZ
6	25410875/0	1	MASCHERINA SINISTRA	LEFT GRILL	PANNEAU GAUCHE	LINKE SCHUTZ
7	12735405/0	6	VITE	SCREW	VIS	SCHRAUBE
8	25108025/0	1	CONVOGLIATORE	CONVEYOR	CONVOYEUR	KONVEYOR
10	25260000/0	2	GOMMINO	GROMMET	PROTECTION	SCHUTZ
11	25120179/0	1	CRUSCOTTO	DASHBOARD	TABLEAU COMMANDES	KONSOLE
14	12735110/0	2	VITE	SCREW	VIS	SCHRAUBE
15	12437502/0	2	PIASTRINA	PLATE	PLAQUE	PLATTE
16	12735402/0	3	VITE	SCREW	VIS	SCHRAUBE
17	25785053/1	1	SUPPORTO CRUSCOTTO	DASHBOARD SUPPORT	SUPPORT TABLEAU COMM.	KONSOLEHALTER
18	82110001/3	1	COPERTURA RUOTE	WHEELS COVER	COUVRE-ROUES	RADENKAPPE
18	82110007/3	1	COPERTURA RUOTE (hydro)	WHEELS COVER (hydro)	COUVRE-ROUES (hydro)	RADENKAPPE (hydro)
19	25110264/1	1	COPRIPEDANA DESTRA	RIGHT FOOTBOARDCOVER	COUVRE MARCHEPIED DRO.	RECHTE FUSSBRETTDECKEL
20	25110263/1	1	COPRIPEDANA SINISTRA	LEFT FOOTBOARD COVER	COUVRE MARCHEPIED GAU.	LINKE FUSSBRETTDECKEL
21	12735410/0	6	VITE	SCREW	VIS	SCHRAUBE
22	12735402/0	4	VITE	SCREW	VIS	SCHRAUBE
23	12728680/0	1	VITE	SCREW	VIS	SCHRAUBE
24	12523040/0	5	ROSETTA	WASHER	RONDELLE	SCHEIBE
25	12523050/0	4	ROSETTA	WASHER	RONDELLE	SCHEIBE
26	25730016/0	1	SEPARATORE ASPIR. (Honda)	INTAKE SEPARATOR (Honda)	SEPARATEUR ASPIR. (Honda)	AUGENABSCHIEDER (Honda)
27	25510068/0	2	PERNO	PIN	PIVOT	BOLZEN
28	12293201/0	2	DADO	NUT	ECROU	MUTTER
29	24487998/0	1	COPPIGLIA	COTTER PIN	GOUPILLE	SPLIT
31	82000207/0	1	ACCELERATORE	ACCELERATOR	ACCELERATEUR	GAS ZUG
32	12788512/0	2	VITE	SCREW	VIS	SCHRAUBE





N.	CODE	Q.TY	DESCRIZIONE	DESCRIPTION	DESCRIPTION	BESCHREIBUNG
33	12581200/0	2	GROWER	GROWER	GROWER	GROWER
34	25394501/0	1	MANOPOLINA	HANDLE	POIGNE	GRIF
35	12726388/0	1	VITE	SCREW	VIS	SCHRAUBE
36	12290800/0	1	DADO	NUT	ECROU	MUTTER
41	25722463/0	1	SEDILE	SEAT	SIEGE	SITZ
43	25547033/1	1	PIASTRA	PLATE	PLAQUE	PLATTE
44	12793101/0	4	VITE	SCREW	VIS	SCHRAUBE
45	12583500/0	4	GROWER	GROWER	GROWER	GROWER
46	12523060/0	4	RONDELLA	WASHER	RONDELLE	SCHIBE
47	25430223/2	1	MOLLA	SPRING	RESSORT	FEDER
48	12789000/0	1	VITE	SCREW	VIS	SCHRAUBE
49	12154330/0	1	DADO	NUT	ECROU	MUTTER
51	25961212/0	1	VOLANTE	STEERING WHEEL	VOLANT	LENKRAD
52	12620299/0	1	SPINA	PIN	GOUPILLE	STIFT
54	27063021/0	1	CAMMA	CAM	CAME	NOCKEN
55	12789100/0	2	VITE	SCREW	VIS	SCHRAUBE
56	12523020/0	2	RONDELLA	WASHER	RONDELLE	SCHIBE
57	12154330/0	2	DADO	NUT	ECROU	MUTTER
61	25110179/1	1	COPERTURA	COVER	COUVRE	KAPPE
62	25600061/0	1	PROTEZ. DESTRA, GRIGIA	RIGHT GUARD, GREY	PROTECTION DROITE, GRIS	RECHTE SCHUTZE, GRAU
63	25600065/0	1	PROTEZ. SINISTRA, GRIGIA	LEFT GUARD, GREY	PROTECTION GAUCHE, GRIS	LINKE SCHUTZE, GRAU
64	12735402/0	6	VITE	SCREW	VIS	SCHRAUBE
65	12734995/0	2	VITE	SCREW	VIS	SCHRAUBE
66	12735402/0	3	VITE	SCREW	VIS	SCHRAUBE
67	12735402/0	6	VITE	SCREW	VIS	SCHRAUBE
71	25110178/2	1	COPERTURA SACCO	GRASS-CATCHER COVER	COUVRE-BAC	SACKKAPPE
72	12729601/1	4	VITE	SCREW	VIS	SCHRAUBE
73	12521331/0	4	RONDELLA	WASHER	RONDELLE	SCHIBE
81	25600020/0	1	PROTEZIONE SUPERIORE	UPPER GUARD	PROTECTION SUPERIEUR	OBERSCHUTZ
82	25600021/1	1	PROTEZIONE INFERIORE	LOWER GUARD	PROTECTION INFERIEUR	UNTERSCHUTZ
83	12728460/0	2	VITE	SCREW	VIS	SCHRAUBE
84	12521320/0	2	ROSETTA	WASHER	RONDELLE	SCHIBE
85	12437502/0	2	PIASTRINA	PLATE	PLAQUE	PLÄTTE
91	25735116/1	1	SERBATOIO	TANK	RESERVOIR	TANK
92	25795000/1	1	TAPPO	CAP	BOUCHON	TANKVERSCHLUSS
93	25774258/0	1	SUPPORTO	SUPPORT	SUPPORT	HALTER
94	12735110/0	1	VITE	SCREW	VIS	SCHRAUBE
101	82869019/0	1	PROTEZIONE SILENZIATORE	MUFFLER PROTECTION	PROTECTION SILENCIEUX	AUSPUFFSCHUTZ
102	18737857/0	2	PUNTALE	CAP	BOUCHON	PFROPFEN
103	12734995/0	4	VITE	SCREW	VIS	SCHRAUBE
104	25547109/1	2	PIASTRINA	PLATE	PLAQUE	PLATTE
106	12731580/0	4	VITE	SCREW	VIS	SCHRAUBE

www.encyclicmotoculture.com

J	JP	JT	JR	JTP	JB	JX
---	----	----	----	-----	----	----

92

92 hydro

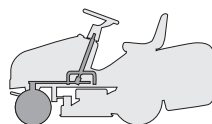

STERZO
STEERING
BARRE DE DIRECTION
LENKGETRIEBE

2004

003.0

1 / 2

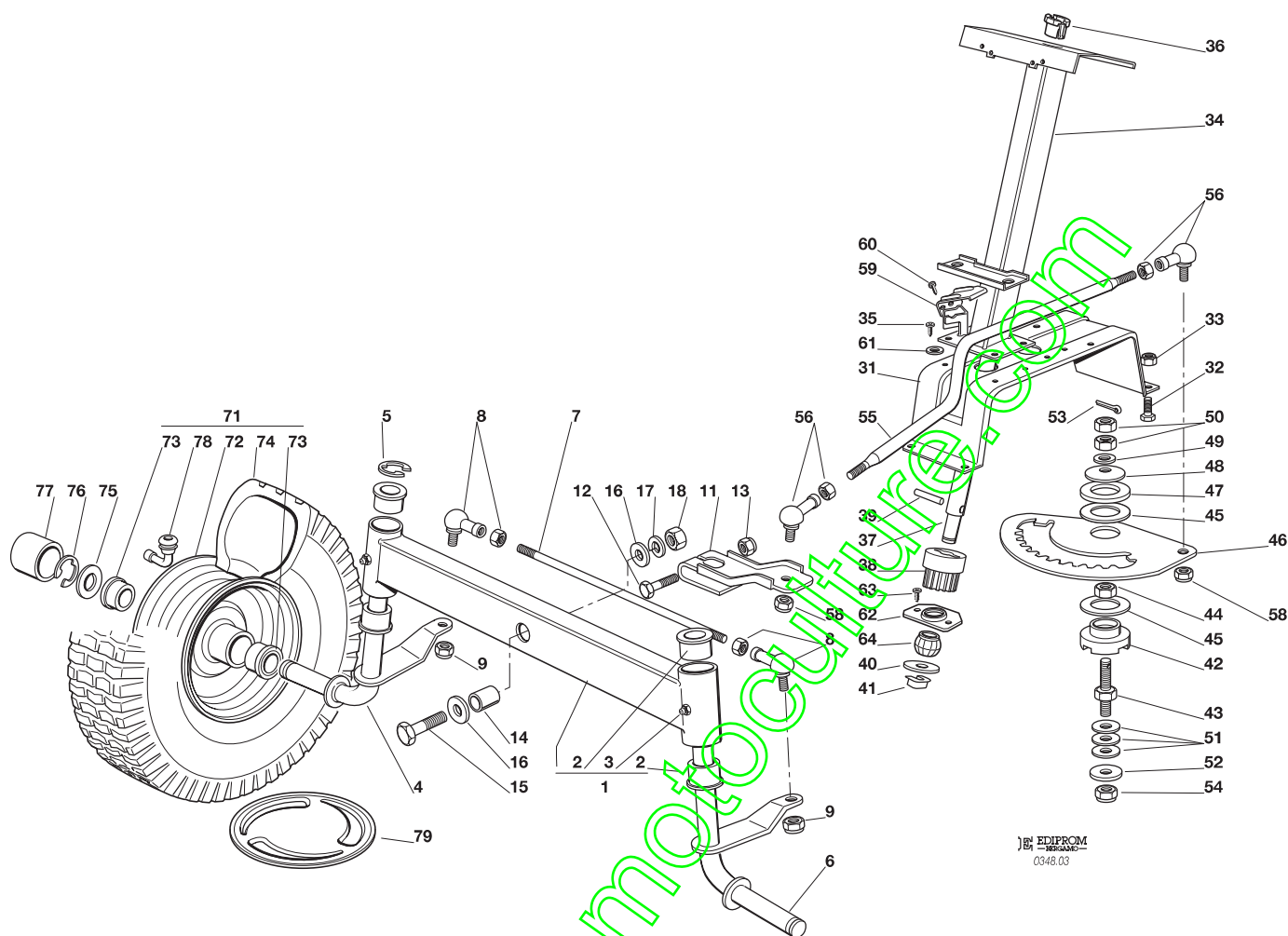

EDIPROM
 0348.03

N.	CODE	Q.TY	DESCRIZIONE	DESCRIPTION	DESCRIPTION	BESCHREIBUNG
1	82034008/0	1	BILANCIERE CON BOCCOLA ED INGRASSATORE	EQUALIZER WITH BUSH AND LUBRICATOR	BALANCIER AVEC DOUILLE ET GRAISSEUR	KIPPHEBEL MIT BÜCHSE UND FETTBÜCHSE
2	25034002/1	4	BOCCOLA	BUSH	DOUILLE	BÜCHSE
3	12379511/0	2	INGRASSATORE	GREASE DISPENSER	GRAISSEUR	FETTBÜCHSE
4	82230355/0	1	FUSELLO DESTRO	RIGHT STUB AXLE	FUSEAU DROITE	RECHTER ACHSSCHENKEL
5	12001000/0	1	ANELLO ELASTICO	SNAP RING	ANNEAU RESSORT	SPRENGRING
6	82230357/0	1	FUSELLO SINISTRO	LEFT STUB AXLE	FUSEAU GAUCHE	LINKER ACHSSCHENKEL
7	25840006/0	1	TIRANTE COLLEG. FUSELLI	TIE ROD	TIRANT	SPANNSTANGE
8	22746600/0	2	SNODO	JOINT	JOINT	GELENK
9	12156602/0	2	DADO	NUT	ECROU	MUTTER
11	25318142/0	1	LEVA	LEVER	LEVIER	HEBEL
12	12692390/0	1	VITE	SCREW	VIS	SCHRAUBE
13	12156602/0	1	DADO	NUT	ECROU	MUTTER
14	25160016/0	1	DISTANZIALE	SPACER	ENTRETOISE	ENTFERNUNGSSTÜCK
15	12692695/0	1	VITE	SCREW	VIS	SCHRAUBE
16	12523100/0	2	RONDELLA	WASHER	RONDELLE	SCHEIBE
17	12587100/0	1	GROWER	GROWER	GROWER	GROWER
18	12295300/0	1	DADO	NUT	ECROU	MUTTER
31	25785101/0	1	SUPPORTO	SUPPORT	SUPPORT	HALTER
32	12792611/0	4	VITE	SCREW	VIS	SCHRAUBE
33	12155000/0	4	DADO	NUT	ECROU	MUTTER
34	82785135/0	1	SUPPORTO	SUPPORT	SUPPORT	HALTER
35	12735120/0	4	VITE	SCREW	VIS	SCHRAUBE
36	25038004/0	1	BOCCOLA	BUSH	DOUILLE	BÜCHSE
37	25520004/0	1	PIANTONE	STEERING COLUMN	TUBE DE DIRECTION	LENKUNGSÄULE
38	25570000/1	1	PIGNONE	PIGNON	PIGNON	RITZEL
39	12622650/0	1	SPINA	PIN	GOUILLE	STIFT
40	12521370/0	1	RONDELLA	WASHER	RONDELLE	SCHEIBE
41	12436030/0	1	PIASTRINA	PLATE	PLAQUETTE	PLATTECHEN





N.	CODE	Q.TY	DESCRIZIONE	DESCRIPTION	DESCRIPTION	BESCHREIBUNG
42	25040617/0	1	BUSSOLA	BUSH	DOUILLE	BÜCHSE
43	25510065/1	1	PERNO	PIN	PIVOT	BOLZEN
44	12295200/0	1	DADO	NUT	ECROU	MUTTER
45	25670012/0	2	RONDELLA	WASHER	RONDELLE	SCHEIBE
46	25735507/0	1	SETTORE	STEERING SHAFT	ARBRE DIRECTION	LENKUNGSWELLE
47	25670014/0	1	RONDELLA	WASHER	RONDELLE	SCHEIBE
48	22160400/0	1	DISCO ELASTICO	ELASTIC WASHER	DISQUE ELASTIQUE	FEDERSCHEIBE
49	12521360/0	1	ROSETTA	WASHER	RONDELLE	SCHEIBE
50	12295200/0	2	DADO	NUT	ECROU	MUTTER
51	22672150/0	3	RONDELLA	WASHER	RONDELLE	SCHEIBE
52	12523080/0	1	RONDELLA	WASHER	RONDELLE	SCHEIBE
53	12141418/0	1	COPPIGLIA	COTTER PIN	GOUPILLE	SPIT
54	12156602/0	1	DADO	NUT	ECROU	MUTTER
55	25033025/0	1	ASTA COM. STERZO	STEERING ROD DIRECTION	LEVIER BARRE DE	LENKUNGSSTAB
56	22746600/0	2	SNODO	JOINT	JOINT	GELENK
58	12156602/0	2	DADO	NUT	ECROU	MUTTER
59	25600036/0	1	PROTEZIONE MICRO	MICRO PROTECTION	PROTECTION MICRO	SCHUTZ
60	12727810/0	2	VITE	SCREW	VIS	SCHRAUBE
61	12521330/0	2	RONDELLA (J - JP)	WASHER (J - JP)	RONDELLE (J - JP)	SCHEIBE (J - JP)
62	25785213/0	1	SUPPORTO	SUPPORT	SUPPORT	HALTER
63	12729601/1	2	VITE	SCREW	VIS	SCHRAUBE
64	25743000/0	1	SNODO	JOINT	JOINT	GELENK
71	82680002/1	2	RUOTA ANTERIORE TURF SAVER CARLISLE	FRONT WHEEL TURF SAVER CARLISLE	ROUE AVANT TURF SAVER CARLISLE	VORDERRAD TURF SAVER CARLISLE
	82680005/0		DELI TIRE	DELI TIRE	DELI TIRE	DELI TIRE
72	82000590/0	2	CERCHIO RUOTA	RIMM	BANDAGE ROUE	VORDERRAD FELGER
73	25122200/2	4	CUSCINETTO	BEARING	ROULEMENT	LAGER
74	25590000/0	2	PNEUMATICO TURF SAVER CARLISLE	SHOE TURF SAVER CARLISLE	PNEU TURF SAVER CARLISLE	REIFEN TURF SAVER CARLISLE
	25590002/0		DELI TIRE	DELI TIRE	DELI TIRE	DELI TIRE
75	25670005/1	2	RONDELLA	WASHER	RONDELLE	SCHEIBE
76	12001000/0	2	ANELLO ELASTICO	SNAP RING	ANNEAU RESSORT	SPRENGRING
77	22110230/0	2	COPRIMOZZO	HUB COVER	COUVRE MOYEU	NABEDECKEL
78	25950002/0	2	VALVOLA	VALVE	SOUPAPE	VENTIL
79	82110252/0	2	COPRIMOZZO	HUB COVER	COUVRE MOYEU	NABEDECKEL

www.emc-motoculture.com

J JP JT JR JTP JB JX

92

92 hydro

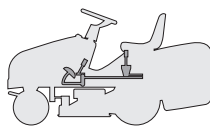

COMANDO FRENO E COMANDO CAMBIO
BRAKE AND GEARBOX CONTROLS
COMMANDE FREIN ET BOITE DE VITESSE
BREMSE UND WECHSEL ANTRIEB

2004

004M.0

1 / 2

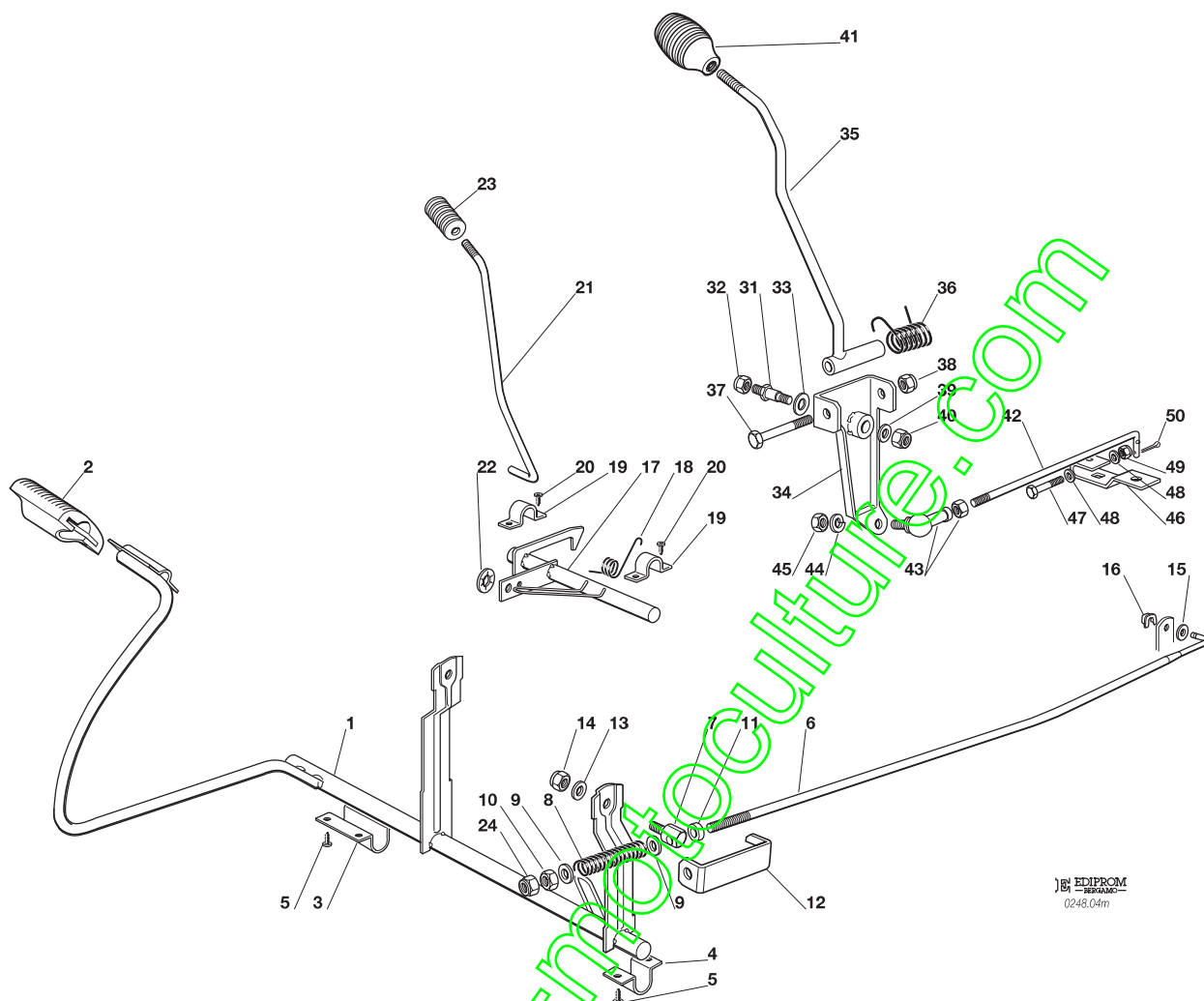

EDIPROM
SERVIZIO
0248,04m

N.	CODE	Q.TY	DESCRIZIONE	DESCRIPTION	DESCRIPTION	BESCHREIBUNG
1	82500002/1	1	PEDALE	PEDAL	PEDAL	PEDAL
2	25110269/0	1	COPRISTAFFA	CLAMP COVER	COUVRE ETRIER	BRIDEDECKEL
3	25547039/0	1	PIASTRINA DESTRA	RIGHT PLATE	PLAQUE DROITE	RECHTE PLATTE
4	25547041/0	1	PIASTRINA SINISTRA	LEFT PLATE	PLATE GAUCHE	LINKE PLATTE
5	12731601/0	6	VITE	SCREW	VIS	SCHRAUBE
6	25033036/0	1	ASTA	ROD	BARRE	STANGE
7	25510060/0	1	PERNO	PIN	PIVOT	BOLZEN
8	25430236/0	1	MOLLA	SPRING	RESSORT	FEDER
9	12521360/0	2	ROSETTA	WASHER	RONDELLE	SCHEIBE
10	12295200/0	1	DADO	NUT	ECROU	MUTTER
11	25160026/0	1	DISTANZIALE	SPACER	ENTRETOISE	ENTFERNUNGSSTÜCK
12	25774275/0	1	STAFFA	CLAMP	ETRIER	BRIDE
13	12523040/0	1	RONDELLA	WASHER	RONDELLE	SCHEIBE
14	12154510/0	1	DADO	NUT	ECROU	MUTTER
15	12521350/0	1	RONDELLA	WASHER	RONDELLE	SCHEIBE
16	12436050/0	1	PIASTRINA	PLATE	PLAQUE	PLATTE
17	82000361/0	1	ASSE AZIONAM. MICRO	AXLE	AXE	ACHSE
18	25430234/0	1	MOLLA	SPRING	RESSORT	FEDER
19	25547049/0	2	PIASTRINA	PLATE	PLAQUE	PLATTE
20	12731601/0	4	VITE	SCREW	VIS	SCHRAUBE
21	25033043/0	1	ASTA	ROD	BARRE	STANGE
22	12604898/0	1	FISSATORE A CORONA	CROWN FASTENER	FIXATEUR A COURONNE	KRONSCHEIBE
23	27395050/1	1	MANOPOLA	KNOB	POIGNEE	KNOPF
24	12156602/0	1	DADO	NUT	ECROU	MUTTER
31	25510035/0	1	PERNO	PIN	PIVOT	BOLZEN
32	12155010/0	1	DADO	NUT	ECROU	MUTTER
33	22672151/0	1	RONDELLA	WASHER	RONDELLE	SCHEIBE
34	82774206/0	1	STAFFA	CLAMP	ETRIER	BRIDE
35	82318134/1	1	LEVA	GEARSHIFT	LEVIER	HEBEL





N.	CODE	Q.TY	DESCRIZIONE	DESCRIPTION	DESCRIPTION	BESCHREIBUNG
36	25430226/0	1	MOLLA	SPRING	RESSORT	FEDER
37	12692050/0	1	VITE	SCREW	VIS	SCHRAUBE
38	12155000/0	1	DADO	NUT	ECROU	MUTTER
39	12523060/0	1	RONDELLA	WASHER	RONDELLE	SCHEIBE
40	12155010/0	1	DADO	NUT	ECROU	MUTTER
41	25394510/0	1	MANOPOLA	KNOB	POIGNEE	WECHSEL
42	25033012/0	1	ASTA	ROD	BARRE	STANGE
43	22746601/0	1	SNODO	JOINT	JOINT	GELENK
44	12583500/0	1	GROWER	GROWER	GROWER	GROWER
45	12293200/0	1	DADO	NUT	ECROU	MUTTER
46	25318128/0	1	LEVA	GEARSHIFT	LEVIER	HEBEL
47	12689500/0	1	VITE	SCREW	VIS	SCHRAUBE
48	12521330/0	2	RONDELLA	WASHER	RONDELLE	SCHEIBE
49	12154510/0	1	DADO	NUT	ECROU	MUTTER
50	12141418/0	1	COPPIGLIA	COTTER PIN	GOUPILLE	SPLIT

www.emc-motoculture.com

J JP JT JR JTP JB JX

92

92 hydro

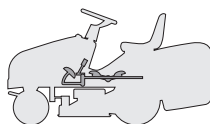

COMANDO TRASMISSIONE E FRENO
DRIVE AND BRAKE CONTROLS
COMMANDE TRANSMISSION ET FREIN
GETRIEBE UND BREMSE ANTRIEB

2004

004Y.0

1 / 2

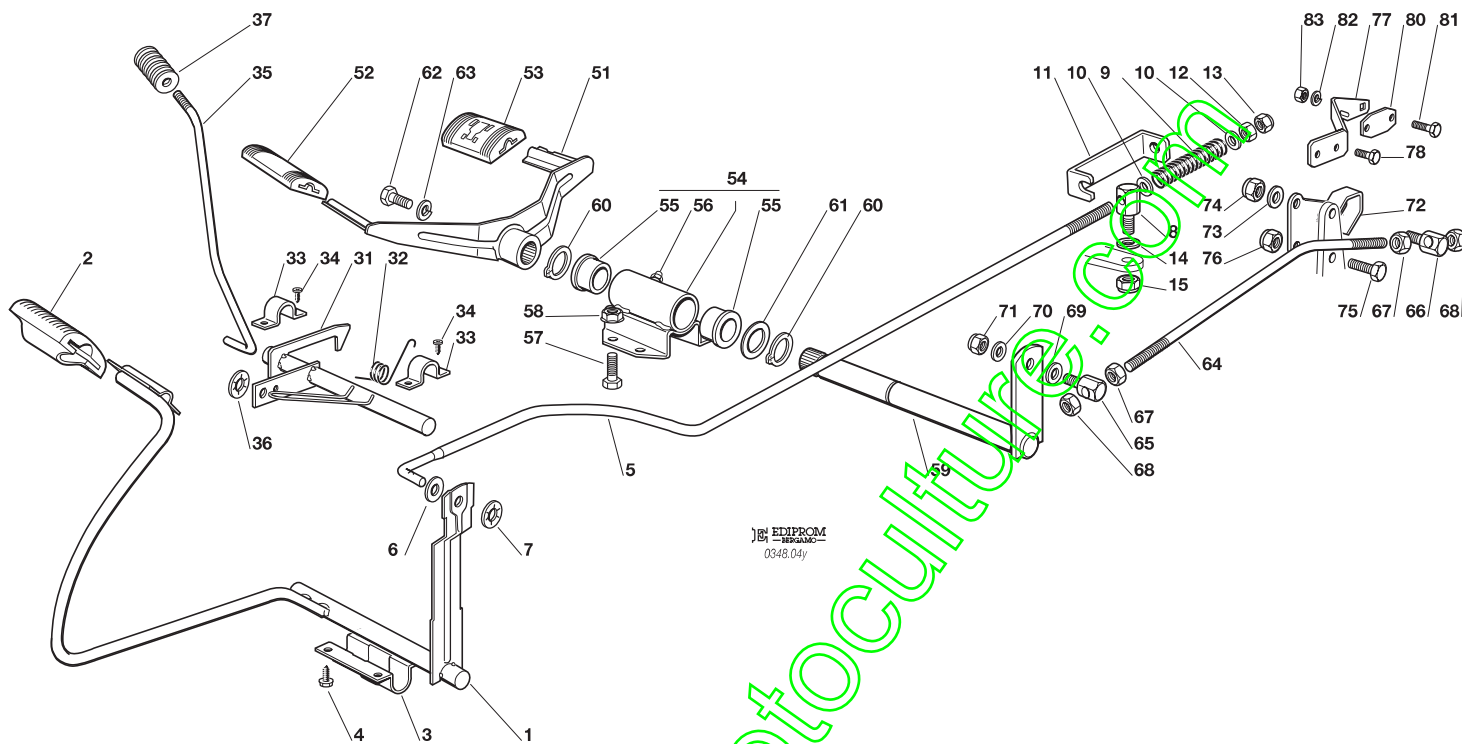

EDIPROM
0348.04y

N.	CODE	Q.TY	DESCRIZIONE	DESCRIPTION	DESCRIPTION	BESCHREIBUNG
1	82500017/0	1	PEDALE	PEDAL	PEDAL	PEDAL
2	25110267/0	1	COPRISTAFFA	CLAMP COVER	COUVRE ETRIER	BRIDEDECKEL
3	25547039/0	1	PIASTRINA	PLATE	PLAQUE	PLATTE
4	12731601/0	4	VITE	SCREW	VIS	SCHRAUBE
5	25033041/0	1	ASTA	ROD	BARRE	STANGE
6	12521350/0	1	ROSETTA	WASHER	RONDELLE	SCHEIBE
7	12604899/0	1	FISSATORE A CORONA	CROWN FASTENER	FIXATEUR A COURONNE	KRONESCHEIBE
8	25510067/1	1	PERNO	PIN	PIVOT	BOLZEN
9	25430236/0	1	MOLLA	SPRING	RESSORT	FEDER
10	12521360/0	2	ROSETTA	WASHER	RONDELLE	SCHEIBE
11	25774275/0	1	STAFFA	CLAMP	ETRIER	BRIDE
12	12295200/0	1	DADO	NUT	ECROU	MUTTER
13	12156602/0	1	DADO	NUT	ECROU	MUTTER
14	12521350/0	1	RONDELLA	WASHER	RONDELLE	SCHEIBE
15	12155000/0	1	DADO	NUT	ECROU	MUTTER
31	82000361/0	1	ASSE AZIONAM. MICRO	AXLE	AXE	ACHSE
32	25430234/0	1	MOLLA	SPRING	RESSORT	FEDER
33	25547049/0	2	PIASTRINA	PLATE	PLAQUE	PLATTE
34	12731601/0	4	VITE	SCREW	VIS	SCHRAUBE
35	25033043/0	1	ASTA	ROD	BARRE	STANGE
36	12604898/0	1	FISSATORE A CORONA	CROWN FASTENER	FIXATEUR A COURONNE	KRONESCHEIBE
37	27395050/1	1	MANOPOLA	KNOB	POIGNEE	KNOPF
51	82500008/0	1	PEDALE AVANZAMENTO	DRIVE PEDAL	PEDALE TRANSMISSION	GETRIEBEPEDAL
52	25110265/0	1	COPRISTAFFA ANTERIORE	CLAMP COVER FRONT	COUVRE ETRIER AVANT	BRIDEDECKEL VORDE
53	25110266/0	1	COPRISTAFFA POSTERIORE	CLAMP COVER REAR	COUVRE ETRIER ARRIERE	BRIDEDECKEL HINTER
54	82785110/0	1	SUPPORTO	SUPPORT	SUPPORT	HALTER
55	25034002/1	2	BRONZINA	BUSH	DOUILLE	BÜCHSE





N.	CODE	Q.TY	DESCRIZIONE	DESCRIPTION	DESCRIPTION	BESCHREIBUNG
56	12379511/0	1	INGRASSATORE	GREASE DISPENSER	GRAISSEUR	FETTBÜCHSE
57	12791011/0	2	VITE	SCREW	VIS	SCHRAUBE
58	12292102/0	2	DADO	NUT	ECROU	MUTTER
59	82318183/0	1	LEVA	GEARSHIFT	LEVIER	HEBEL
60	12609260/0	2	SEEGER	SEEGER	SEEGER	SEEGER
61	22672153/0	1	RONDELLA	WASHER	RONDELLE	SCHEIBE
62	12792612/0	1	VITE	SCREW	VIS	SCHRAUBE
63	12583501/0	1	GROWER	GROWER	GROWER	GROWER
64	25033042/0	1	ASTA	ROD	BARRE	STANGE
65	25510054/0	1	PERNO	PIN	PIVOT	BOLZEN
66	25510066/0	1	PERNO	PIN	PIVOT	BOLZEN
67	12293200/0	2	DADO	NUT	ECROU	MUTTER
68	12155000/0	2	DADO	NUT	ECROU	MUTTER
69	12521360/0	1	RONDELLA	WASHER	RONDELLE	SCHEIBE
70	12523040/0	1	RONDELLA	WASHER	RONDELLE	SCHEIBE
71	12154510/0	1	DADO	NUT	ECROU	MUTTER
72	82774231/0	1	CAMMA	CAM	CAME	KAMM
73	12523040/0	1	RONDELLA	WASHER	RONDELLE	SCHEIBE
74	12154510/0	1	DADO	NUT	ECROU	MUTTER
75	12791213/1	1	VITE	SCREW	VIS	SCHRAUBE
76	12154510/0	1	DADO	NUT	ECROU	MUTTER
77	25774289/0	1	STAFFA	CLAMP	ETRIER	BRIDE
78	12735110/0	2	VITE	SCREW	VIS	SCHRAUBE
80	27546019/0	1	PIASTRINA	PLATE	PLAQUETTE	PLATTE
81	12735602/0	2	VITE	SCREW	VIS	SCHRAUBE
82	12581100/0	2	GROWER	GROWER	GROWER	GROWER
83	12290791/0	2	DADO	NUT	ECROU	MUTTER

www.emc-motoculture.com

J	JP	JT	JR	JTP	JB	JX
---	----	----	----	-----	----	----

92

92 hydro

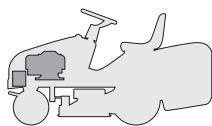

MOTORE
ENGINE
MOTEUR
MOTOR

12 - 12,5 - 13,5 HP B&S

2004

005.0

1 / 1

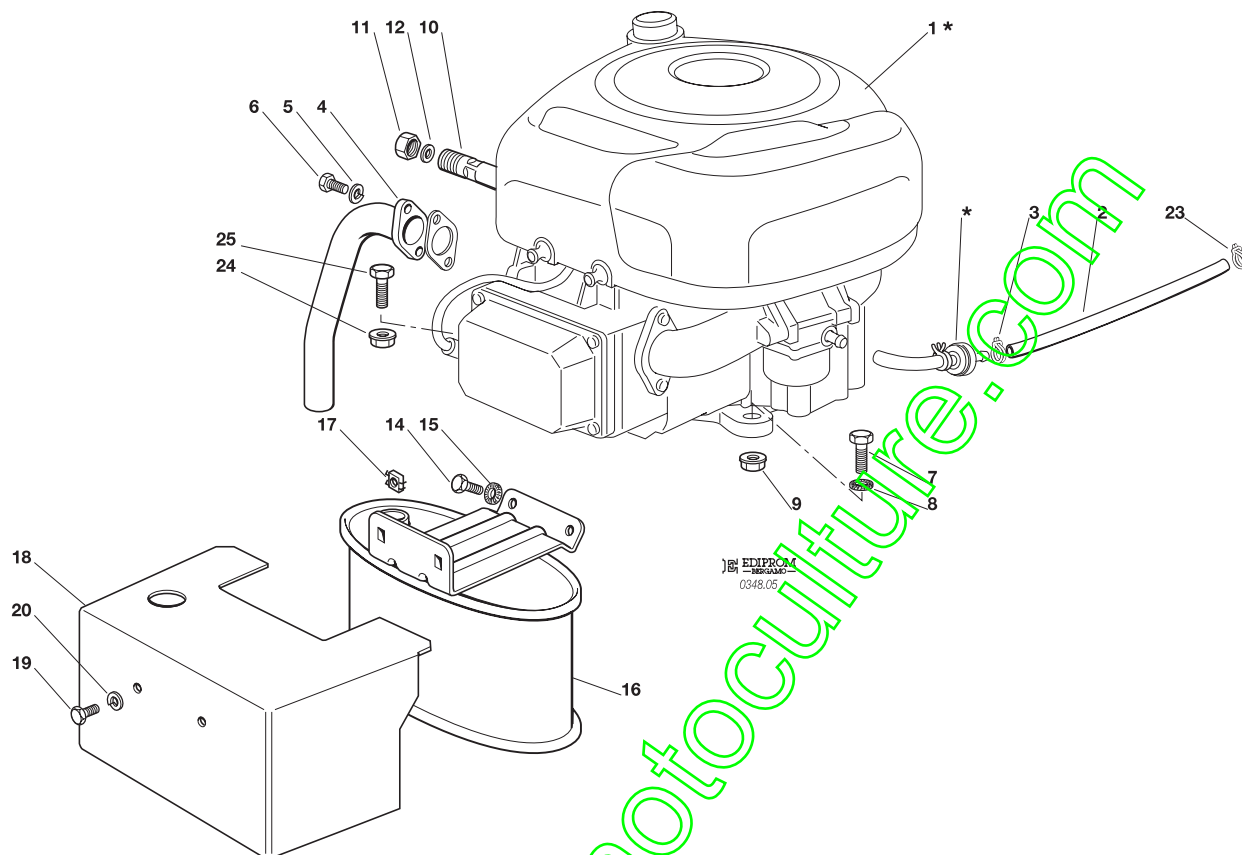

N.	CODE	Q.TY	DESCRIZIONE	DESCRIPTION	DESCRIPTION	BESCHREIBUNG
1*	—	1	MOTORE	ENGINE	MOTEUR	MOTOR
2	25869016/0	1	TUBO COLLEGAMENTO	CONNECTING TUBE	TUBE DE CONNEXION	VERBINDUNGSROHR
3	18375051/1	1	FASCETTA	FAIR LED	FIXATION DE CABLE	KABELBEFESTIGUNG
4	18738224/0	1	TUBO SCARICO	EXHAUST TUBE	TUBE ECHAPPEMENT	ABGASUNGROHR
5	12583500/0	2	GROWER	GROWER	GROWER	GROWER
6	12735530/0	2	VITE	SCREW	VIS	SCHRAUBE
7	12691115/0	1	VITE	SCREW	VIS	SCHRAUBE
8	12540260/0	1	RONDELLA	WASHER	RONDELLE	SCHEIBE
9	12154210/0	1	DADO	NUT	ECROU	MUTTER
10	25598050/0	1	PROLUNGA SCARICO OLIO	OIL DISCHARGE EXTENSION	EXTENSION DECH. HUILE	ÖL ABFLUSS
11	18737849/0	1	TAPPO PROLUNGA	OIL CAP	BOUCHON HUILE	OELVERSCHLUSS
12	18401001/1	1	GUARNIZIONE	OIL SEAL	GARNITURE	DICHTUNG
14	12793102/0	2	VITE	SCREW	VIS	SCHRAUBE
15	12540260/0	2	RONDELLA	WASHER	RONDELLE	SCHEIBE
16	82750004/0	1	SILENZIATORE	MUFFLER	SILENCEUX	AUSPUFF
17	12360425/0	2	DADO	NUT	ECROU	MUTTER
18	82598009/2	1	PROTEZIONE	GUARD	PROTECTION	SCHUTZE
19	12792611/0	2	VITE	SCREW	VIS	SCHRAUBE
20	12583500/0	2	GROWER	GROWER	GROWER	GROWER
23	18375053/0	1	FASCETTA	FAIR LED	FIXATION DE CABLE	KABELBEFESTIGUNG
24	12154210/0	3	DADO	NUT	ECROU	MUTTER
25	12691100/0	3	VITE	SCREW	VIS	SCHRAUBE

PER LA SOSTITUZIONE DELLE PARTI CONTRASSEGNAE CON «*» RIVOLGERSI AL SERVIZIO ASSISTENZA DEL COSTRUTTORE DEL MOTORE.
 TO REPLACE THE PARTS MARKED «*» SEEK ASSISTANCE FROM THE ENGINE MANUFACTURER'S AFTER SALES SERVICE.
 POUR LE REMPLACEMENT DES PIÈCES MARQUÉES AVEC «*» S'ADRESSER AU SERVICE APRÈS VENTES DU CONSTRUCTEUR DU MOTEUR.
 ZUM AUSTAUSCH DER MIT «*» GEKENNZEICHNETEN TEILE, WENDEN SIE SICH AN DEN KUNDENDIENST DES HERSTELLERS DES MOTOR.

J	JP	JT	JR	JTP	JB	JX
---	----	----	----	-----	----	----

92

92 hydro

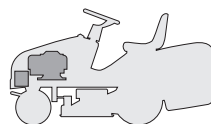

MOTORE
ENGINE
MOTEUR
MOTOR

13 - 13,5 HP TECUMSEH

2004

005a.0

1 / 1

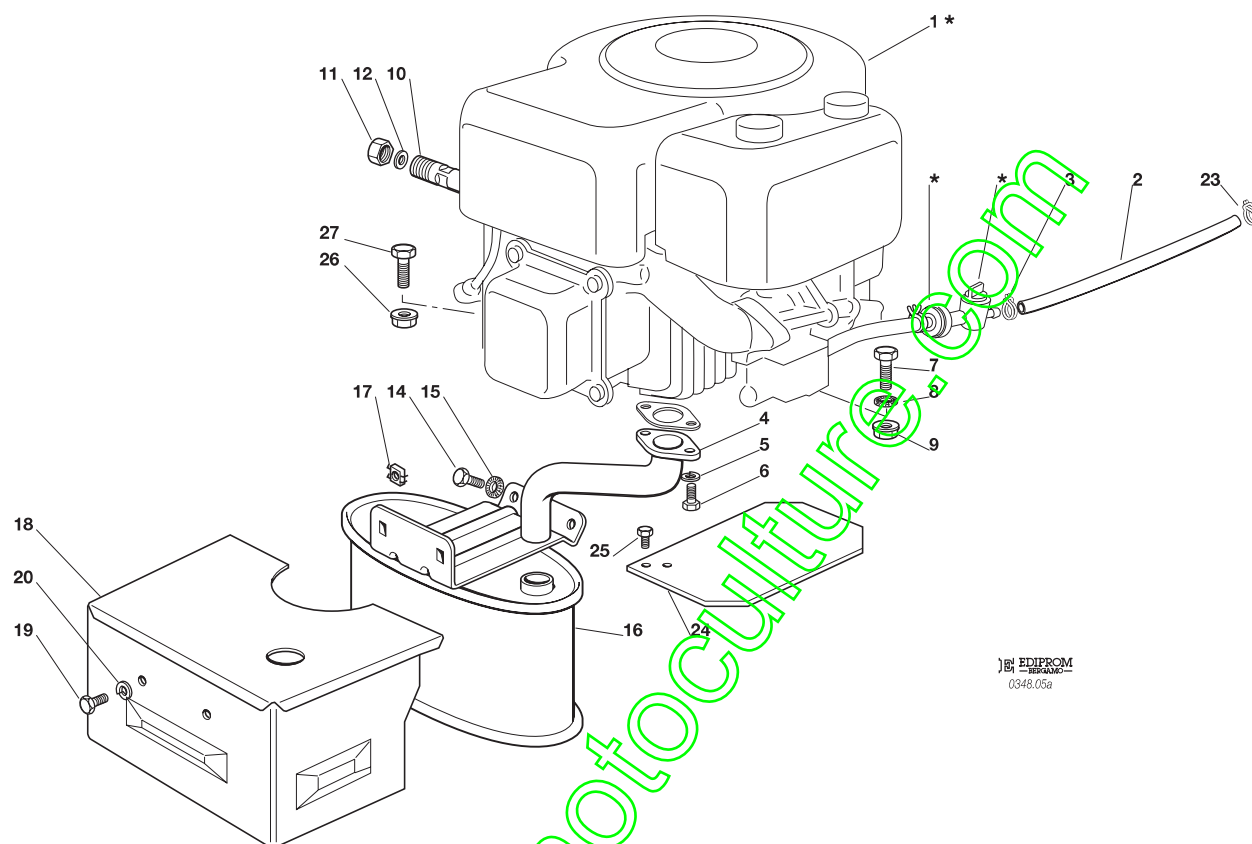

N.	CODE	Q.TY	DESCRIZIONE	DESCRIPTION	DESCRIPTION	BESCHREIBUNG
1*	—	1	MOTORE	ENGINE	MOTEUR	MOTOR
2	25869010/0	1	TUBO COLLEGAMENTO	CONNECTING TUBE	TUBE DE CONNEXION	VERBINDUNGSROHR
3	18375051/1	4	FASCETTA	FAIR LED	FIXATION DE CABLE	KABELBEFESTIGUNG
4	18738211/0	1	TUBO SCARICO	EXHAUST TUBE	TUBE ECHAPPEMENT	ABGASUNGROHR
5	12583500/0	2	GROWER	GROWER	GROWER	GROWER
6	12735530/0	2	VITE	SCREW	VIS	SCHRAUBE
7	12691115/0	1	VITE	SCREW	VIS	SCHRAUBE
8	12540260/0	1	RONDELLA	WASHER	RONDELLE	SCHEIBE
9	12154210/0	1	DADO	NUT	ECROU	MUTTER
10	25598050/0	1	PROLUNGA SCARICO OLIO	OIL DISCHARGE EXTENSION	EXTENSION DECH. HUILE	ÖL ABFLUSS
11	18737849/0	1	TAPPO PROLUNGA	OIL CAP	BOUCHON HUILE	OELVERSCHLUSS
12	18401001/1	1	GUARNIZIONE	OIL SEAL	GARNITURE	DICHTUNG
14	12793102/0	2	VITE	SCREW	VIS	SCHRAUBE
15	12540260/0	2	RONDELLA	WASHER	RONDELLE	SCHEIBE
16	82750005/0	1	SILENZIATORE	MUFFLER	SILENCEUX	AUSPUFF
17	12360425/0	2	DADO	NUT	ECROU	MUTTER
18	82598017/0	1	PROTEZIONE	GUARD	PROTECTION	SCHUTZE
19	12792611/0	2	VITE	SCREW	VIS	SCHRAUBE
20	12583500/0	2	GROWER	GROWER	GROWER	GROWER
23	18375053/0	1	FASCETTA	FAIR LED	FIXATION DE CABLE	KABELBEFESTIGUNG
24	25600031/0	1	PROTEZIONE SILENZIATORE	MUFFLER PROTECTION	PROTECTION SILENCIEUX	AUSPUFFSCHUTZ
25	12735106/0	2	VITE	SCREW	VIS	SCHRAUBE
26	12154210/0	3	DADO	NUT	ECROU	MUTTER
27	12691100/0	3	VITE	SCREW	VIS	SCHRAUBE

PER LA SOSTITUZIONE DELLE PARTI CONTRASSEGNALE CON «*» RIVOLGERSI AL SERVIZIO ASSISTENZA DEL COSTRUTTORE DEL MOTORE.
 TO REPLACE THE PARTS MARKED «*» SEEK ASSISTANCE FROM THE ENGINE MANUFACTURER'S AFTER SALES SERVICE.
 POUR LE REMPLACEMENT DES PIÈCES MARQUÉES AVEC «*» S'ADRESSER AU SERVICE APRÈS VENTES DU CONSTRUCTEUR DU MOTEUR.
 ZUM AUSTAUSCH DER MIT «*» GEKENNZEICHNETEN TEILE, WENDEN SIE SICH AN DEN KUNDENDIENST DES HERSTELLERS DES MOTOR.

J	JP	JT	JR	JTP	JB	JX
---	----	----	----	-----	----	----

92

92 hydro

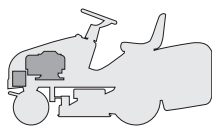

MOTORE
ENGINE
MOTEUR
MOTOR
15 - 15,5 HP B&S

2004

005b.0

1 / 1

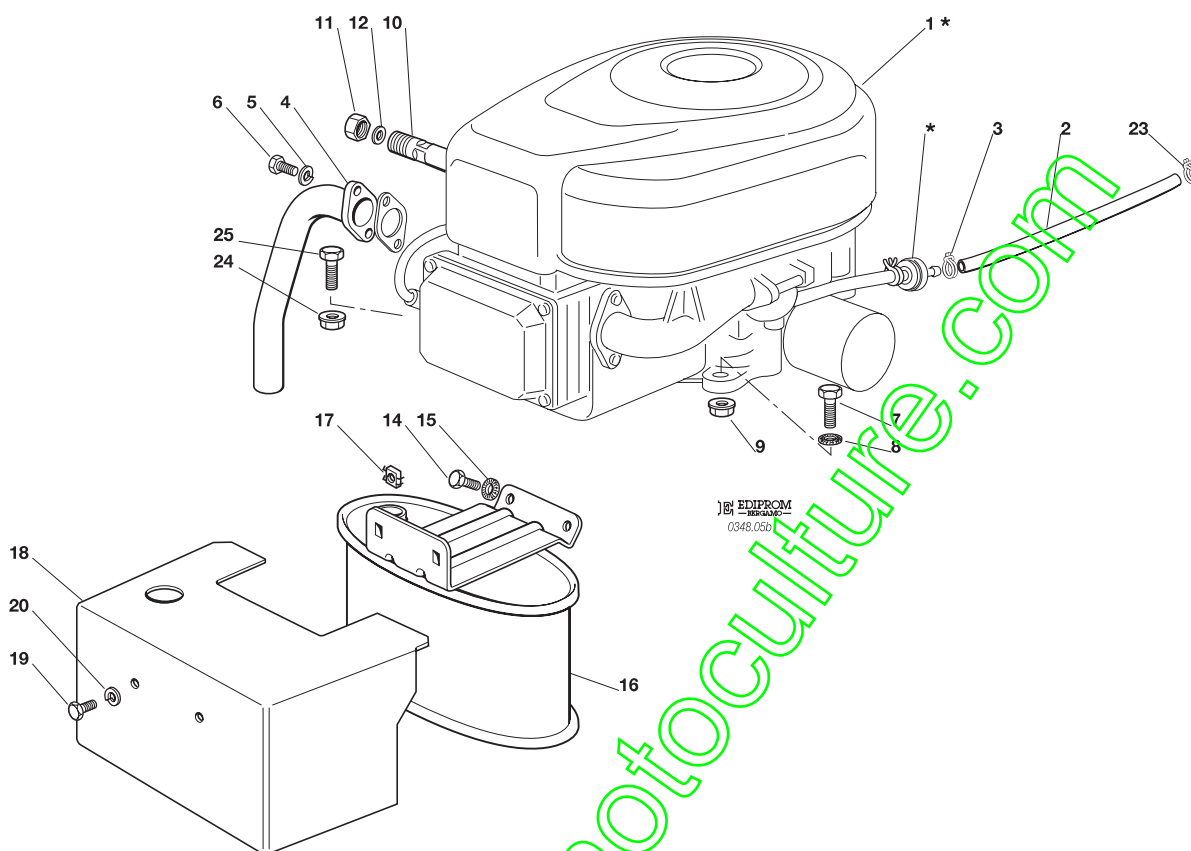

N.	CODE	Q.TY	DESCRIZIONE	DESCRIPTION	DESCRIPTION	BESCHREIBUNG
1*	—	1	MOTORE	ENGINE	MOTEUR	MOTOR
2	25869016/0	1	TUBO COLLEGAMENTO	CONNECTING TUBE	TUBE DE CONNEXION	VERBINDUNGSROHR
3	18375051/1	1	FASCETTA	FAIR LED	FIXATION DE CABLE	KABELBEFESTIGUNG
4	18738206/0	1	TUBO SCARICO	EXHAUST TUBE	TUBE ECHAPPEMENT	ABGASUNGROHR
5	12583500/0	2	GROWER	GROWER	GROWER	GROWER
6	12735530/0	2	VITE	SCREW	VIS	SCHRAUBE
7	12691115/0	1	VITE	SCREW	VIS	SCHRAUBE
8	12540260/0	1	RONDELLA	WASHER	RONDELLE	SCHEIBE
9	12154210/0	1	DADO	NUT	ECROU	MUTTER
10	25598050/0	1	PROLUNGA SCARICO OLIO	OIL DISCHARGE EXTENSION	EXTENSION DECH. HUILE	ÖL ABFLUSS
11	18737849/0	1	TAPPO PROLUNGA	OIL CAP	BOUCHON HUILE	OELVERSCHLUSS
12	18401001/1	1	GUARNIZIONE	OIL SEAL	GARNITURE	DICHTUNG
14	12793102/0	2	VITE	SCREW	VIS	SCHRAUBE
15	12540260/0	2	RONDELLA	WASHER	RONDELLE	SCHEIBE
16	82750004/0	1	SILENZIATORE	MUFFLER	SILENCEUX	AUSPUFF
17	12360425/0	2	DADO	NUT	ECROU	MUTTER
18	82598009/2	1	PROTEZIONE	GUARD	PROTECTION	SCHUTZE
19	12792611/0	2	VITE	SCREW	VIS	SCHRAUBE
20	12583500/0	2	GROWER	GROWER	GROWER	GROWER
23	18375053/0	1	FASCETTA	FAIR LED	FIXATION DE CABLE	KABELBEFESTIGUNG
24	12154210/0	3	DADO	NUT	ECROU	MUTTER
25	12691100/0	3	VITE	SCREW	VIS	SCHRAUBE

PER LA SOSTITUZIONE DELLE PARTI CONTRASSEGNALE CON «*» RIVOLGERSI AL SERVIZIO ASSISTENZA DEL COSTRUTTORE DEL MOTORE.
TO REPLACE THE PARTS MARKED «*» SEEK ASSISTANCE FROM THE ENGINE MANUFACTURER'S AFTER SALES SERVICE.
POUR LE REMPLACEMENT DES PIÈCES MARQUÉES AVEC «*» S'ADRESSER AU SERVICE APRÈS VENTES DU CONSTRUCTEUR DU MOTEUR.
ZUM AUSTAUSCH DER MIT «*» GEKENNZEICHNETEN TEILE, WENDEN SIE SICH AN DEN KUNDENDIENST DES HERSTELLERS DES MOTOR.

J

JP

JT

JR

JTP

JB

JX

92

92 hydro

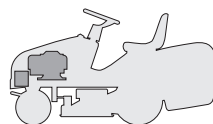

MOTORE
ENGINE
MOTEUR
MOTOR
HONDA GCV 520

2004

005c.0

1 / 1

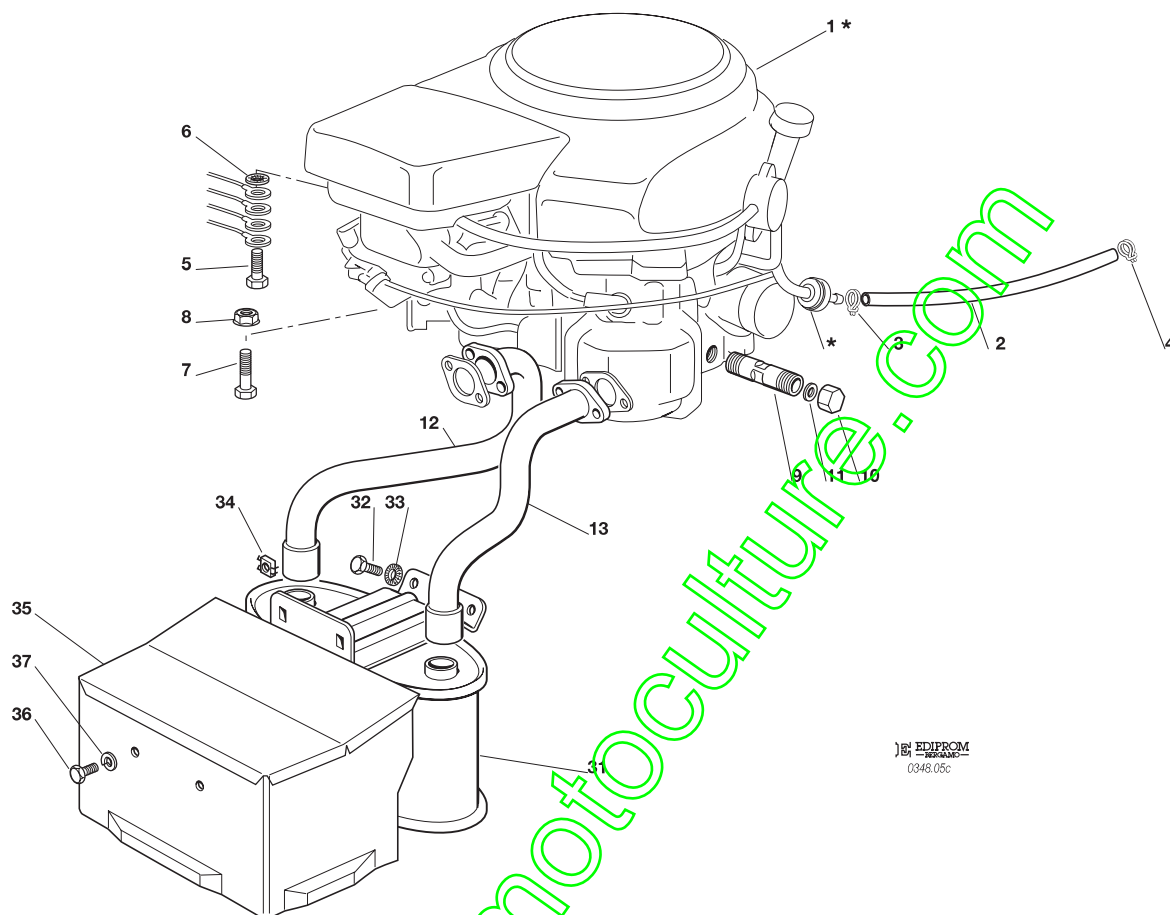

EDIPROM
0348.05c

N.	CODE	Q.TY	DESCRIZIONE	DESCRIPTION	DESCRIPTION	BESCHREIBUNG
1*	—	1	MOTORE	ENGINE	MOTEUR	MOTOR
2	25869027/0	1	TUBO COLLEGAMENTO	CONNECTING TUBE	TUBE DE CONNEXION	VERBINDUNGSROHR
3	18375051/1	1	FASCETTA	FAIR LED	FIXATION DE CABLE	KABELBEFESTIGUNG
4	18375053/0	1	FASCETTA	FAIR LED	FIXATION DE CABLE	KABELBEFESTIGUNG
5	12735599/0	1	VITE	SCREW	VIS	SCHRAUBE
6	12540260/0	1	RONDELLA	WASHER	RONDELLE	SCHEIBE
7	12691115/0	4	VITE	SCREW	VIS	SCHRAUBE
8	12154221/0	4	DADO	NUT	ECROU	MUTTER
9	25598051/0	1	PROLUNGA SCARICO OLIO	OIL DISCHARGE EXTENSION	EXTENSION DECH. HUILE	ÖL ABFLUSS
10	18737849/0	1	TAPPO PROLUNGA	OIL CAP	BOUCHON HUILE	OELVERSCHLUSS
11	18401001/1	1	GUARNIZIONE	OIL SEAL	GARNITURE	DICHTUNG
12	18738221/0	1	TUBO SCARICO DESTRO	EXHAUST TUBE RIGHT	TUBE ECHAPPEMENT DROIT	ABGASUNGROHR, RECHTE
13	18738222/0	1	TUBO SCARICO SINISTRO	EXHAUST TUBE LEFT	TUBE ECHAPPEMENT GAU.	ABGASUNGROHR, LINKE
31	82750003/0	1	SILENZIATORE	MUFFLER	SILENCEUX	AUSPUFF
32	12793102/0	2	VITE	SCREW	VIS	SCHRAUBE
33	12540260/0	2	RONDELLA	WASHER	RONDELLE	SCHEIBE
34	12360425/0	2	DADO	NUT	ECROU	MUTTER
35	82598005/2	1	PROTEZIONE	GUARD	PROTECTION	SCHUTZE
36	12792611/0	2	VITE	SCREW	VIS	SCHRAUBE
37	12583500/0	2	GROWER	GROWER	GROWER	GROWER

PER LA SOSTITUZIONE DELLE PARTI CONTRASSEGNALE CON «*» RIVOLGERSI AL SERVIZIO ASSISTENZA DEL COSTRUTTORE DEL MOTORE.
TO REPLACE THE PARTS MARKED «*» SEEK ASSISTANCE FROM THE ENGINE MANUFACTURER'S AFTER SALES SERVICE.
POUR LE REMPLACEMENT DES PIÈCES MARQUÉES AVEC «*» S'ADRESSER AU SERVICE APRÈS VENTES DU CONSTRUCTEUR DU MOTEUR.
ZUM AUSTAUSCH DER MIT «*» GEKENNZEICHNETEN TEILE, WENDEN SIE SICH AN DEN KUNDENDIENST DES HERSTELLERS DES MOTOR.

J JP JT JR JTP JB JX

92

92 hydro

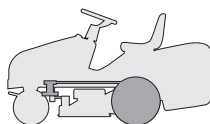

TRASMISSIONE
TRANSMISSION
TRANSMISSION
GETRIEBE

2004

006M.0

1 / 2

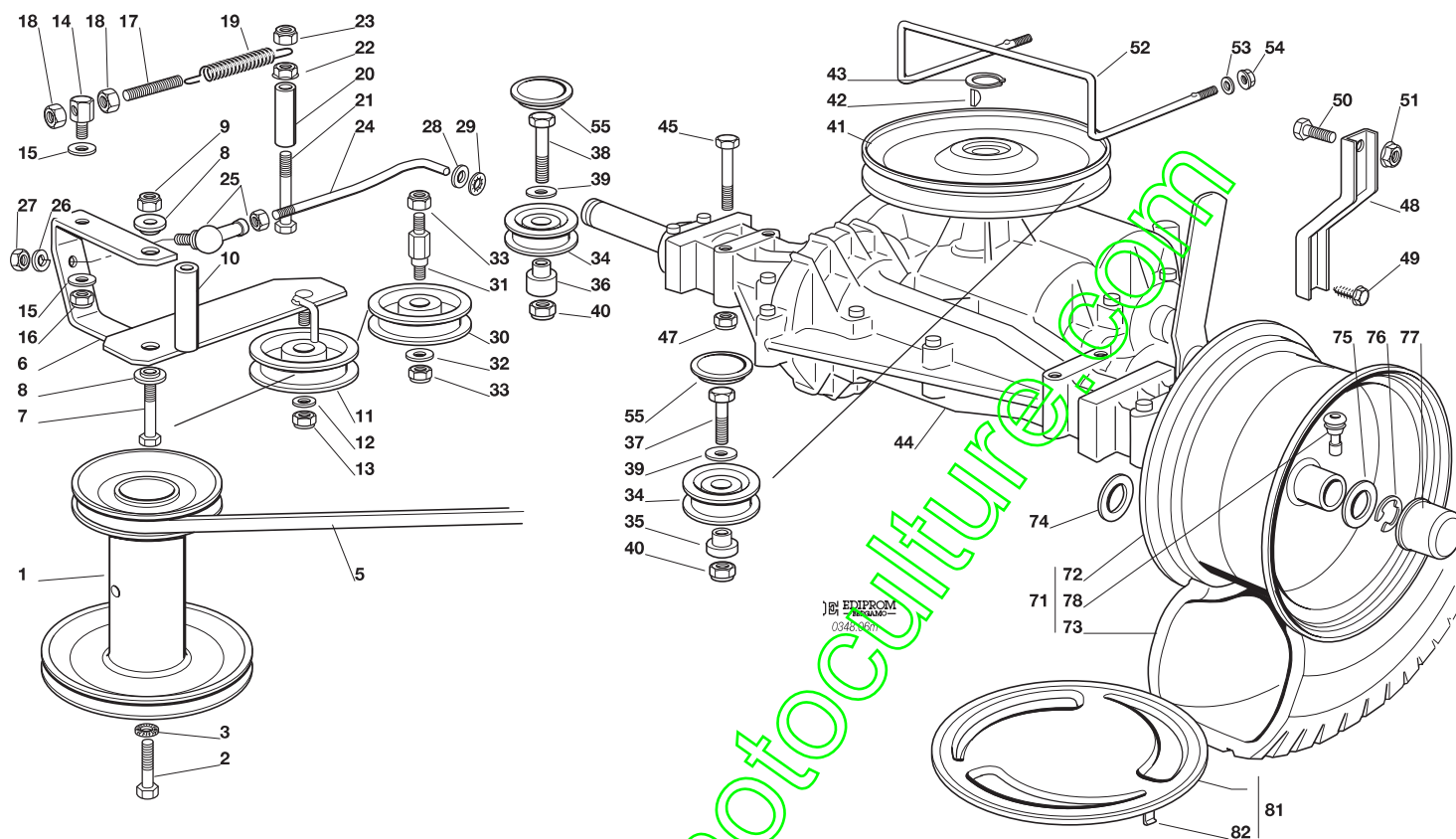

N.	CODE	Q.TY	DESCRIZIONE	DESCRIPTION	DESCRIPTION	BESCHREIBUNG
1	25601547/1	1	PULEGGIA	PULLEY	POULIE	RIEMENSCHIBE
2	12737310/0	1	VITE	SCREW	VIS	SCHRAUBE
3	12543000/0	1	ROSETTA	WASHER	RONDELLE	SCHEIBE
5	35062000/1	1	CINGHIA	BELT	COURROIE	RIEMEN
6	82318133/0	1	LEVA	LEVER	LEVIER	HEBEL
7	12692080/0	1	VITE	SCREW	VIS	SCHRAUBE
8	25038002/1	2	BOCCOLA	BUSH	DOUILLE	BÜCHSE
9	12155000/0	1	DADO	NUT	ECROU	MUTTER
10	25160017/0	1	DISTANZIALE	SPACER	ENTRETOISE	ENTFERNUNGSSTÜCK
11	25601554/0	1	PULEGGIA	PULLEY	POULIE	RIEMENSCHIBE
12	12523060/0	1	RONDELLA	WASHER	RONDELLE	SCHEIBE
13	12155000/0	1	DADO	NUT	ECROU	MUTTER
14	25510040/1	1	PERNO	PIN	PIVOT	BOLZEN
15	25670011/0	2	RONDELLA	WASHER	RONDELLE	SCHEIBE
16	12155000/0	1	DADO	NUT	ECROU	MUTTER
17	25840005/0	1	TIRANTE	TIE ROD	TIRANT	SPANNSTANGE
18	12293200/0	2	DADO	NUT	ECROU	MUTTER
19	25430219/0	1	MOLLA	SPRING	RESSORT	FEDER
20	25160008/0	1	DISTANZIALE	SPACER	ENTRETOISE	ENTFERNUNGSSTÜCK
21	12692050/0	1	VITE	SCREW	VIS	SCHRAUBE
22	12293201/0	1	DADO	NUT	ECROU	MUTTER
23	12155000/0	1	DADO	NUT	ECROU	MUTTER
24	25840002/0	1	TIRANTE	TIE ROD	TIRANT	SPANNSTANGE
25	22746601/0	1	SNODO	JOINT	JOINT	GELENK
26	12583500/0	1	GROWER	GROWER	GROWER	GROWER
27	12293200/0	1	DADO	NUT	ECROU	MUTTER
28	12521350/0	1	RONDELLA	WASHER	RONDELLE	SCHEIBE
29	12604899/0	1	FISSATORE A CORONA	CROWN FASTENER	FIXATEUR A COURONNE	KRONESCHIBE
30	25601555/0	1	PULEGGIA	PULLEY	POULIE	RIEMENSCHIBE
31	25510036/1	1	PERNO	PIN	PIVOT	BOLZEN
32	12523060/0	1	RONDELLA	WASHER	RONDELLE	SCHEIBE





N.	CODE	Q.TY	DESCRIZIONE	DESCRIPTION	DESCRIPTION	BESCHREIBUNG
33	12155000/0	2	DADO	NUT	ECROU	MUTTER
34	25601570/0	2	PULEGGIA	PULLEY	POULIE	RIEMENSCHIBE
35	25160018/0	1	DISTANZIALE SINISTRO	LEFT SPACER	ENTRETOISE GAUCHE	LINKER ENTFERNUNGSSTÜCK
36	25160014/0	1	DISTANZIALE DESTRO	RIGHT SPACER	ENTRETOISE DROITE	RECHTER ENTFERNUNGSSTÜCK
37	12691100/0	1	VITE SINISTRA	LEFT SCREW	VIS GAUCHE	LINKE SCHRAUBE
38	12691200/0	1	VITE DESTRA	RIGHT SCREW	VIS DROITE	RECHTE SCHRAUBE
39	12523060/0	2	RONDELLA	WASHER	RONDELLE	SCHEIBE
40	12155000/0	2	DADO	NUT	ECROU	MUTTER
41	82601503/0	1	PULEGGIA	PULLEY	POULIE	RIEMENSCHIBE
42	12139430/0	1	LINGUETTA	KEY	CLAVETTE	KEIL
43	12608950/0	1	ANELLO ELASTICO	SNAP RING	ANNEAU RESSORT	SPRENGRING
44*	18400910/2	1	ASSE POSTERIORE	REAR AXLE	AXE ARRIERE	HINTERACHSE
45	12691800/0	4	VITE	SCREW	VIS	SCHRAUBE
47	12154210/0	4	DADO	NUT	ECROU	MUTTER
48	25774247/0	2	STAFFA	CLAMP	ETRIER	BRIDE
49	12735150/0	2	VITE	SCREW	VIS	SCHRAUBE
50	12792611/0	2	VITE	SCREW	VIS	SCHRAUBE
51	12293201/0	2	DADO	NUT	ECROU	MUTTER
52	25270303/1	1	GUIDACINGHIA	BELT GUIDE	GUIDE DE COURROIRE	RIEMENFÜHRUNG
53	12521330/0	2	RONDELLA	WASHER	RONDELLE	SCHEIBE
54	12292102/0	2	DADO	NUT	ECROU	MUTTER
55	25109521/1	2	COPERCHIO	COVER	COUVERCLE	DECKEL
71	82680003/0	2	RUOTA POSTERIORE TURF SAVER CARLISLE	REAR WHEEL TURF SAVER CARLISLE	ROUE ARRIERE TURF SAVER CARLISLE	HINTERRAD TURF SAVER CARLISLE
	82680006/0		DELI TIRE	DELI TIRE	DELI TIRE	DELI TIRE
72	82000592/0	2	CERCHIO RUOTA	RIMM	BANDAGE ROUE	HINTERRAD FELGER
73	25590001/0	2	PNEUMATICO TURF SAVER CARLISLE	SHOE TURF SAVER CARLISLE	PNEU TURF SAVER CARLISLE	REIFEN TURF SAVER CARLISLE
	25590003/0		DELI TIRE	DELI TIRE	DELI TIRE	DELI TIRE
74	12521410/0	2-4	RONDELLA	WASHER	RONDELLE	SCHEIBE
75	25670005/1	2	RONDELLA	WASHER	RONDELLE	SCHEIBE
76	12001010/0	2	ANELLO ELASTICO	SNAP RING	ANNEAU RESSORT	SPRENGRING
77	22110230/0	2	COPRIMOZZO	HUB COVER	COUVRE MOYEU	NABEDECKEL
78	25950000/0	2	VALVOLA	VALVE	SOUPAPE	VENTIL
81	82110253/0	2	COPRIRUOTA POST.	REAR WHEEL DECK	COUVRE ROUE POST.	HINTERRADDECKEL
82	25430209/0	8	MOLLA AGGANCI	SPRING	RESSORT	FEDER

PER LA SOSTITUZIONE IN GARANZIA DELLE PARTI CONTRASSEGNALE CON «*» RIVOLGERSI AL SERVIZIO ASSISTENZA DEL COSTRUTTORE.
 TO REPLACE UNDER GUARANTEE THE PARTS MARKED «*» SEEK ASSISTANCE FROM MANUFACTURER'S AFTER SALES SERVICE.
 POUR LE REMPLACEMENT, SOUS GARANTIE DES PIÈCES MARQUÉES AVEC «*» S'ADRESSER AU SERVICE APRÈS VENTES DU CONSTRUCTEUR.
 ZUM AUSTAUSCH DER MIT «*» GEKENNZEICHNETEN TEILE IM RAHMEN DER GARANTIE, WENDEN SIE SICH AN DEN KUNDENDIENST DES HERSTELLERS.

J	JP	JT	JR	JTP	JB	JX
---	----	----	----	-----	----	----

92

92 hydro

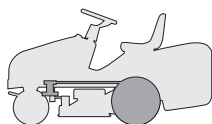

TRASMISSIONE
TRANSMISSION
TRANSMISSION
GETRIEBE

2004

006Y.0

1 / 2

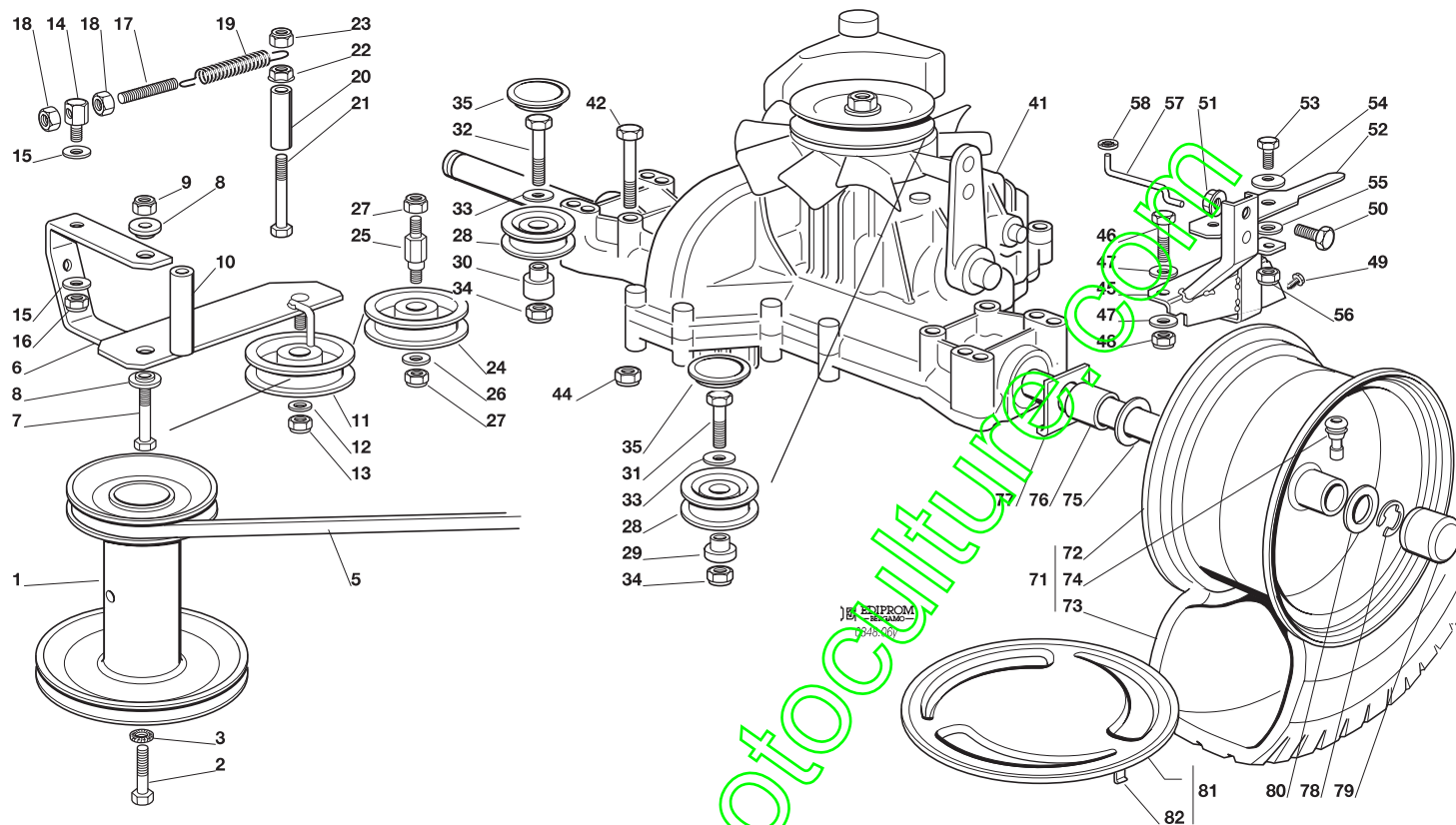

N.	CODE	Q.TY	DESCRIZIONE	DESCRIPTION	DESCRIPTION	BESCHREIBUNG
1	25601548/1	1	PULEGGIA	PULLEY	POULIE	RIEMENSCHLEIBE
2	12737310/0	1	VITE	SCREW	VIS	SCHRAUBE
3	12543000/0	1	ROSETTA	WASHER	RONDELLE	SCHEIBE
5	35061980/0	1	CINGHIA	BELT	COURROIE	RIEMEN
6	82318133/0	1	LEVA	LEVER	LEVIER	HEBEL
7	12692080/0	1	VITE	SCREW	VIS	SCHRAUBE
8	25038002/1	2	BOCCOLA	BUSH	DOUILLE	BÜCHSE
9	12155000/0	1	DADO	NUT	ECROU	MUTTER
10	25160017/0	1	DISTANZIALE	SPACER	ENTRETOISE	ENTFERNUNGSSTÜCK
11	25601554/0	1	PULEGGIA	PULLEY	POULIE	RIEMENSCHLEIBE
12	12523060/0	1	RONDELLA	WASHER	RONDELLE	SCHEIBE
13	12155000/0	1	DADO	NUT	ECROU	MUTTER
14	25510040/1	1	PERNO	PIN	PIVOT	BOLZEN
15	25670011/0	2	RONDELLA	WASHER	RONDELLE	SCHEIBE
16	12155000/0	1	DADO	NUT	ECROU	MUTTER
17	25840005/0	1	TIRANTE	TIE ROD	TIRANT	SPANNSTANGE
18	12293200/0	2	DADO	NUT	ECROU	MUTTER
19	25430219/0	1	MOLLA	SPRING	RESSORT	FEDER
20	25160008/0	1	DISTANZIALE	SPACER	ENTRETOISE	ENTFERNUNGSSTÜCK
21	12692050/0	1	VITE	SCREW	VIS	SCHRAUBE
22	12293201/0	1	DADO	NUT	ECROU	MUTTER
23	12155000/0	1	DADO	NUT	ECROU	MUTTER
24	25601555/0	1	PULEGGIA	PULLEY	POULIE	RIEMENSCHLEIBE
25	25510036/1	1	PERNO	PIN	PIVOT	BOLZEN
26	12523060/0	1	RONDELLA	WASHER	RONDELLE	SCHEIBE
27	12155000/0	2	DADO	NUT	ECROU	MUTTER
28	25601570/0	2	PULEGGIA	PULLEY	POULIE	RIEMENSCHLEIBE
29	25160030/0	1	DISTANZIALE SINISTRO	LEFT SPACER	ENTRETOISE GAUCHE	LINKER ENTFERNUNGSSTÜCK
30	25160024/1	1	DISTANZIALE DESTRO	RIGHT SPACER	ENTRETOISE DROITE	RECHTER ENTFERNUNGSSTÜCK





N.	CODE	Q.TY	DESCRIZIONE	DESCRIPTION	DESCRIPTION	BESCHREIBUNG
31	12691115/0	1	VITE SINISTRA	LEFT SCREW	VIS GAUCHE	LINKE SCHRAUBE
32	12691400/0	1	VITE DESTRA	RIGHT SCREW	VIS DROITE	RECHTE SCHRAUBE
33	12523060/0	2	RONDELLA	WASHER	RONDELLE	SCHEIBE
34	12155000/0	2	DADO	NUT	ECROU	MUTTER
35	25109521/1	2	COPERCHIO	COVER	COUVERCLE	DECKEL
41*	18400960/0	1	ASSE POSTERIORE	REAR AXLE	AXE ARRIERE	HINTERACHSE
42	12691800/0	4	VITE	SCREW	VIS	SCHRAUBE
44	12154210/0	4	DADO	NUT	ECROU	MUTTER
45	82785117/0	1	SUPPORTO	SUPPORT	SUPPORT	HALTER
46	12691200/0	1	VITE	SCREW	VIS	SCHRAUBE
47	12521350/0	2	RONDELLA	WASHER	RONDELLE	SCHEIBE
48	12155000/0	1	DADO	NUT	ECROU	MUTTER
49	12735120/0	2	VITE	SCREW	VIS	SCHRAUBE
50	12792611/0	1	VITE	SCREW	VIS	SCHRAUBE
51	12293201/0	1	DADO	NUT	ECROU	MUTTER
52	25318157/0	1	LEVA	LEVER	LEVIER	HEBEL
53	12793102/0	1	VITE	SCREW	VIS	SCHRAUBE
54	12369500/0	1	DISCO ELASTICO	ELASTIC WASHER	DISQUE ELASTIQUE	FEDERSCHEIBE
55	25670011/0	1	RONDELLA	WASHER	RONDELLE	SCHEIBE
56	12155000/0	1	DADO	NUT	ECROU	MUTTER
57	25033033/0	1	ASTA	ROD	BARRE	STANGE
58	12604896/0	1	FISSATORE A CORONA	CROWN FASTENER	FIXATEUR A COURONNE	KRONESCHEIBE
71	82680003/0	2	RUOTA POSTERIORE TURF SAVER CARLISLE	REAR WHEEL TURF SAVER CARLISLE	ROUE ARRIERE TURF SAVER CARLISLE	HINTERRAD TURF SAVER CARLISLE
	82680006/0		DELI TIRE	DELI TIRE	DELI TIRE	DELI TIRE
72	82000592/0	2	CERCHIO RUOTA	RIMM	BANDAGE ROUE	HINTRERRAD FELGER
73	25590001/0	2	PNEUMATICO TURF SAVER CARLISLE	SHOE TURF SAVER CARLISLE	PNEU TURF SAVER CARLISLE	REIFEN TURF SAVER CARLISLE
	25590003/0		DELI TIRE	DELI TIRE	DELI TIRE	DELI TIRE
74	25950000/0	2	VALVOLA	VALVE	SOUPAPE	VENTIL
75	12521410/0	2-4	RONDELLA	WASHER	RONDELLE	SCHEIBE
76	25160031/0	2	DISTANZIALE	SPACER	ENTRETOISE	ENTFERNUNGSSTÜCK
77	25670017/0	2	RONDELLA	WASHER	RONDELLE	SCHEIBE
78	12001010/0	2	ANELLO ELASTICO	SNAP RING	ANNEAU RESSORT	SPRENGRING
79	22110230/0	2	COPRIMOZZO	HUB COVER	COUVRE MOYEU	NABEDECKEL
80	25670005/1	2	RONDELLA	WASHER	RONDELLE	SCHEIBE
81	82110253/0	2	COPRIRUOTA POST.	REAR WHEEL DECK	COUVRE ROUE POST.	HINTERRADDECKEL
82	25430209/0	8	MOLLA AGGANCIO	SPRING	RESSORT	FEDER

PER LA SOSTITUZIONE IN GARANZIA DELLE PARTI CONTRASSEGNALE CON «*» RIVOLGERSI AL SERVIZIO ASSISTENZA DEL COSTRUTTORE.
 TO REPLACE UNDER GUARANTEE THE PARTS MARKED «*» SEEK ASSISTANCE FROM MANUFACTURER'S AFTER SALES SERVICE.
 POUR LE REMPLACEMENT, SOUS GARANTIE DES PIÈCES MARQUÉES AVEC «*» S'ADRESSER AU SERVICE APRÈS VENTES DU CONSTRUCTEUR.
 ZUM AUSTAUSCH DER MIT «*» GEKENNZEICHNETEN TEILE IM RAHMEN DER GARANTIE, WENDEN SIE SICH AN DEN KUNDENDIENST DES HERSTELLERS.

J

JP

JT

JR

JTP

JB

JX

92

92 hydro

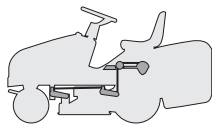

SOLLEVAMENTO PIATTO DI TAGLIO
CUTTING PLATE LIFTING
SOULEVEMENT PLATEAU DE COUPE
SCHNEIDWERKZEUG AUFHEBESATZ

2004

007.0

1 / 2

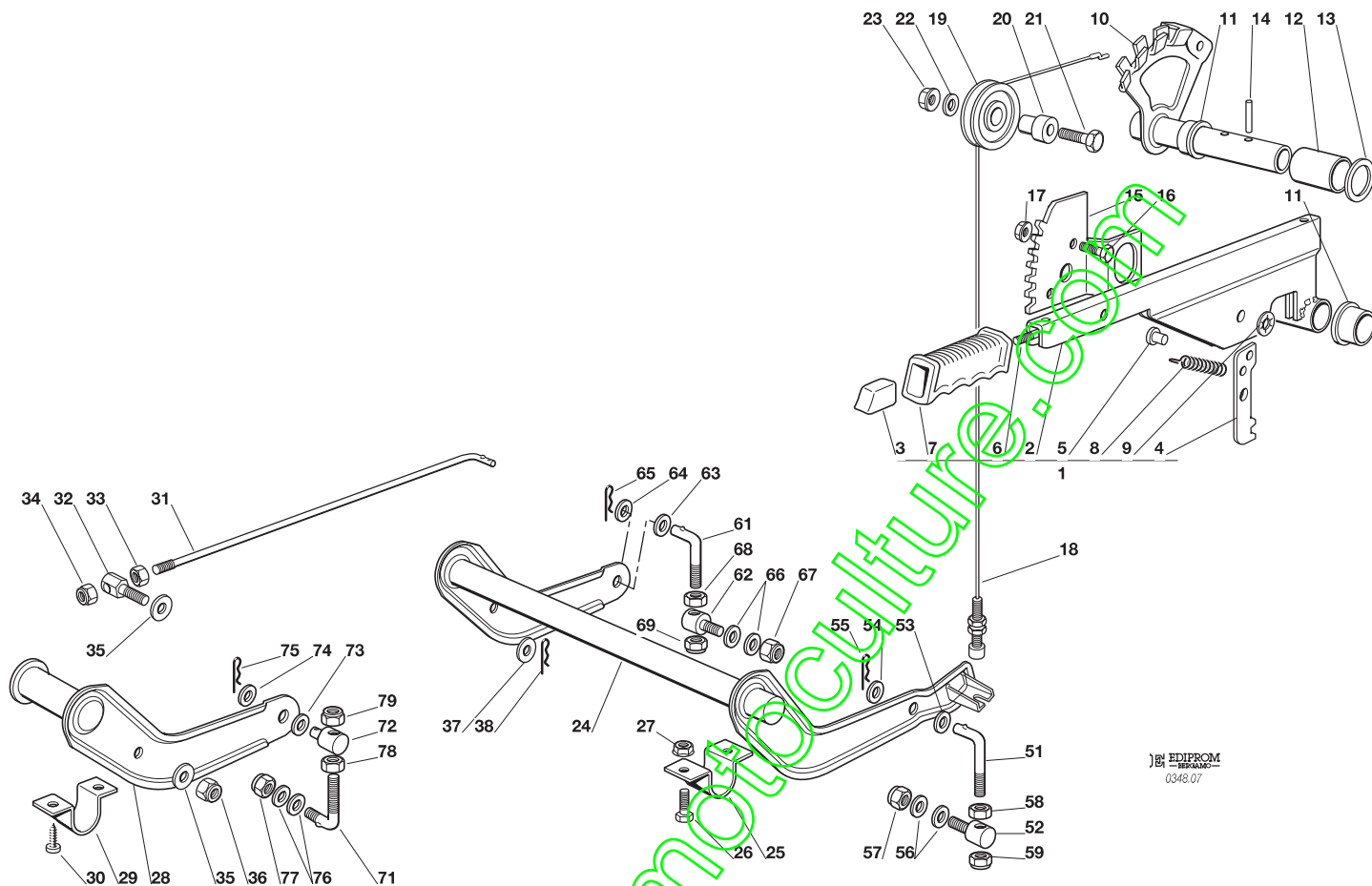

EDIPROM
0348.07

N.	CODE	Q.TY	DESCRIZIONE	DESCRIPTION	DESCRIPTION	BESCHREIBUNG
1	82300002/1	1	ASSIEME LEVA (2÷9)	LEVER ASS.Y (2÷9)	ENS. LEVIER (2÷9)	SCHNEIDWERKZEUG AUFHEBENHEBEL (2÷9)
2	82318139/0	1	LEVA	LEVER	LEVIER	HEBEL
3	25605000/1	1	PULSANTE	BUTTON	POUSSOIR	DRUCKKNOPF
4	25470901/0	1	NASELLO	DOG	DECLIC	NASE
5	25510011/0	1	PERNO	PIN	PIVOT	BOLZEN
6	25033002/0	1	ASTA	ROD	TIGE	STAB
7	25394504/1	1	MANOPOLA	KNOB	POIGNEE	GRIFF
8	25430208/0	1	MOLLA	SPRING	RESSORT	FEDER
9	12604899/0	1	RONDELLA	WASHER	RONDELLE	SCHEIBE
10	82000403/0	1	ASSE	AXLE	AXE	ACHSE
11	22034523/0	2	BOCCOLA	BUSH	DOUILLE	BÜCHSE
12	25160013/0	1	DISTANZIALE	SPACER	ENTRETOISE	ENTFERNUNGSSTÜCK
13	12521410/0	1	RONDELLA	WASHER	RONDELLE	SCHEIBE
14	12620206/0	2	SPINA	PIN	GOUPILLE	STIFT
15	25735506/1	1	SETTORE	SECTOR	SECTEUR	SEKTOR
16	12792611/0	2	VITE	SCREW	VIS	SCHRAUBE
17	12293201/0	2	DADO	NUT	ECROU	MUTTER
18	82004603/0	1	FILO	WIRE	FIL	KABEL
19	25601557/0	1	PULEGGIA	PULLEY	POULIE	RIEMENSCHIEBE
20	25510032/0	1	PERNO	PIN	PIVOT	BOLZEN
21	12691400/0	1	VITE	SCREW	VIS	SCHRAUBE
22	12523060/0	1	RONDELLA	WASHER	RONDELLE	SCHEIBE
23	12293201/0	1	DADO	NUT	ECROU	MUTTER
24	82000381/2	1	ASSE SOLLEVAMENTO	AXLE	AXE	ACHSE
25	25547037/1	2	PIASTRINA	PLATE	PLAQUE	PLATTE
26	12791011/0	4	VITE	SCREW	VIS	SCHRAUBE
27	12292102/0	4	DADO	NUT	ECROU	MUTTER
28	82318137/0	1	LEVA	LEVER	LEVIER	HEBEL
29	25547041/0	2	PIASTRINA	PLATE	PLAQUE	PLATTE
30	12731601/0	4	VITE	SCREW	VIS	SCHRAUBE





N.	CODE	Q.TY	DESCRIZIONE	DESCRIPTION	DESCRIPTION	BESCHREIBUNG
31	25033013/0	1	ASTA	ROD	TIGE	STAB
32	25510040/1	1	PERNO	PIN	PIVOT	BOLZEN
33	12293200/0	1	DADO	NUT	ECROU	MUTTER
34	12155000/0	1	DADO	NUT	ECROU	MUTTER
35	25670011/0	2	RONDELLA	WASHER	RONDELLE	SCHEIBE
36	12155000/0	1	DADO	NUT	ECROU	MUTTER
37	12521350/0	1	RONDELLA	WASHER	RONDELLE	SCHEIBE
38	24487997/0	1	COPPIGLIA	COTTER PIN	GOUPILLE	SPLIT
51	25840003/2	1	TIRANTE	TIE ROD	TIRANT	SPANNSTANGE
52	25510024/0	1	PERNO	PIN	PIVOT	BOLZEN
53	12521360/0	1	RONDELLA	WASHER	RONDELLE	SCHEIBE
54	25670008/1	1	RONDELLA	WASHER	RONDELLE	SCHEIBE
55	24487997/0	1	COPPIGLIA	COTTER PIN	GOUPILLE	SPLIT
56	25670008/1	2	RONDELLA	WASHER	RONDELLE	SCHEIBE
57	12156602/0	1	DADO	NUT	ECROU	MUTTER
58	12295200/0	1	DADO	NUT	ECROU	MUTTER
59	12156602/0	1	DADO	NUT	ECROU	MUTTER
61	25840003/2	1	TIRANTE	TIE ROD	TIRANT	SPANNSTANGE
62	25510024/0	1	PERNO	PIN	PIVOT	BOLZEN
63	12521360/0	1	RONDELLA	WASHER	RONDELLE	SCHEIBE
64	25670008/1	1	RONDELLA	WASHER	RONDELLE	SCHEIBE
65	24487997/0	1	COPPIGLIA	COTTER PIN	GOUPILLE	SPLIT
66	25670008/1	2	RONDELLA	WASHER	RONDELLE	SCHEIBE
67	12156602/0	1	DADO	NUT	ECROU	MUTTER
68	12295200/0	1	DADO	NUT	ECROU	MUTTER
69	12156602/0	1	DADO	NUT	ECROU	MUTTER
71	25840014/0	1	TIRANTE	TIE ROD	TIRANT	SPANNSTANGE
72	25510069/0	1	PERNO	PIN	PIVOT	BOLZEN
73	25670008/1	1	RONDELLA	WASHER	RONDELLE	SCHEIBE
74	12521360/0	1	RONDELLA	WASHER	RONDELLE	SCHEIBE
75	24487997/0	1	COPPIGLIA	COTTER PIN	GOUPILLE	SPLIT
76	25670008/1	2	RONDELLA	WASHER	RONDELLE	SCHEIBE
77	12156602/0	1	DADO	NUT	ECROU	MUTTER
78	12295200/0	1	DADO	NUT	ECROU	MUTTER
79	12156602/0	1	DADO	NUT	ECROU	MUTTER

www.emc-motoculture.com

J	JP	JT	JR	JTP	JB	JX
92				92 hydro		

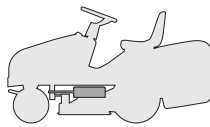

PIATTO DI TAGLIO (1)
 CUTTING PLATE (1)
 PLATEAU DE COUPE (1)
 SCHNEIDWERKZEUG (1)

2004
008.0
1 / 2

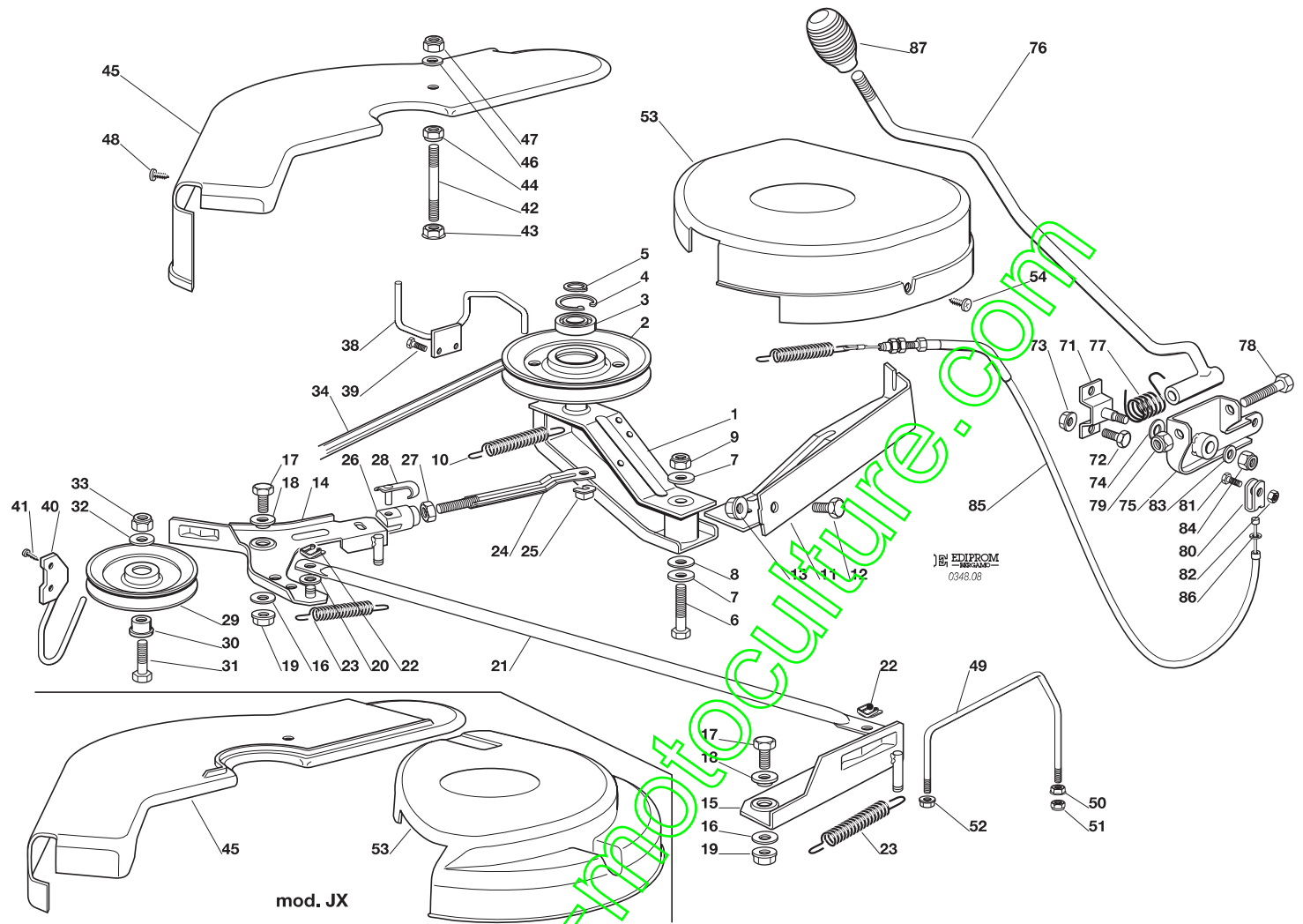

N.	CODE	Q.TY	DESCRIZIONE	DESCRIPTION	DESCRIPTION	BESCHREIBUNG
1	82318141/1	1	LEVA	LEVER	LEVIER	HEBEL
2	25601564/0	1	PULEGGIA	PULLEY	POULIE	RIEMENSCHLEIBE
3	19216033/1	1	CUSCINETTO	BEARING	ROULEMENT	KUEGELLAGER
4	12610800/0	1	ANELLO ELASTICO	SNAP RING	ANNEAU RESSORT	SPRENGRING
5	12609200/0	1	ANELLO ELASTICO	SNAP RING	ANNEAU RESSORT	SPRENGRING
6	12691700/0	1	VITE	SCREW	VIS	SCHRAUBE
7	12523070/0	2	RONDELLA	WASHER	RONDELLE	SCHEIBE
8	22672152/0	1	RONDELLA	WASHER	RONDELLE	SCHEIBE
9	12155000/0	1	DADO	NUT	ECROU	MUTTER
10	22450500/0	1	MOLLA	SPRING	RESSORT	FEDER
11	82774215/2	1	STAFFA	CLAMP	BRIDE	BRIDE
12	12792611/0	1	VITE	SCREW	VIS	SCHRAUBE
13	12293201/0	1	DADO	NUT	ECROU	MUTTER
14	82318143/2	2	LEVA DESTRA	RIGHT LEVER	LEVIER DROITE	RECHTE HEBEL
15	82318148/0	1	LEVA SINISTRA	LEFT LEVER	LEVIER GAUCHE	LINKE HEBEL
16	22672152/0	2	RONDELLA	WASHER	RONDELLE	SCHEIBE
17	12792611/0	2	VITE	SCREW	VIS	SCHRAUBE
18	22041980/0	2	BUSSOLA	BUSH	DOUILLE	BÜCHSE
19	12293201/0	2	DADO	NUT	ECROU	MUTTER
20	25670011/0	1	RONDELLA	WASHER	RONDELLE	SCHEIBE
21	25033024/0	1	ASTA	ROD	TIGE	TAB
22	12436050/0	2	PIASTRINA	PLATE	PLAQUE	PLATTE
23	25430229/1	2	MOLLA	SPRING	RESSORT	FEDER
24	82000499/0	1	ASTA	ROD	TIGE	STAB
25	12436050/0	1	PIASTRINA	PLATE	PLAQUE	PLATTE
26	18399000/0	1	FORCELLA	FORK	FOURCHE	GABEL
27	12292100/0	1	DADO	NUT	ECROU	MUTTER
28	18210200/0	1	CLIP	CLIP	SPERRBOLZEN	SPERRBOLZEN
29	25601555/0	1	PULEGGIA	PULLEY	POULIE	RIEMENSCHLEIBE
30	25160007/0	1	DISTANZIALE	SPACER	ENTRETOISE	ENTFERNUNGSSTÜCK
31	12691100/0	1	VITE	SCREW	VIS	SCHRAUBE





N.	CODE	Q.TY	DESCRIZIONE	DESCRIPTION	DESCRIPTION	BESCHREIBUNG
32	12523060/0	1	RONDELLA	WASHER	RONDELLE	SCHEIBE
33	12155000/0	1	DADO	NUT	ECROU	MUTTER
34	35065700/0	1	CINGHIA	BELT	COURROIRE	KEILRIEMEN
38	25270301/0	1	GUIDACINGHIA	BELT GUIDE	GUIDE DE COURROIRE	RIEMENFÜHRUNG
39	12729601/1	2	VITE	SCREW	VIS	SCHRAUBE
40	25270304/1	1	GUIDACINGHIA	BELT GUIDE	GUIDE DE COURROIRE	RIEMENFÜHRUNG
41	12731601/0	2	VITE	SCREW	VIS	SCHRAUBE
42	25580007/0	1	PRIGIONIERO	STUD SCREW	PRISONNIER	STIFTSCHIEBE
43	12293201/0	1	DADO	NUT	ECROU	MUTTER
44	12293201/0	1	DADO	NUT	ECROU	MUTTER
45	25060102/0	1	CARTER	GUARD	CARTER	BLECH
45	25060111/0	1	CARTER (JX)	GUARD (JX)	CARTER (JX)	BLECH (JX)
46	12523060/0	1	RONDELLA	WASHER	RONDELLE	SCHEIBE
47	12155000/0	2	DADO	NUT	ECROU	MUTTER
48	12735110/0	2	VITE	SCREW	VIS	SCHRAUBE
49	25270316/0	1	GUIDACINGHIA	BELT GUIDE	GUIDE DE COURROIRE	RIEMENFÜHRUNG
50	12293201/0	1	DADO	NUT	ECROU	MUTTER
51	12155000/0	1	DADO	NUT	ECROU	MUTTER
52	12292102/0	1	DADO	NUT	ECROU	MUTTER
53	25060103/0	1	CARTER	GUARD	CARTER	BLECH
53	25060112/0	1	CARTER (JX)	GUARD (JX)	CARTER (JX)	BLECH (JX)
54	12735110/0	2	VITE	SCREW	VIS	SCHRAUBE
71	82785073/0	1	SUPPORTO	SUPPORT	SUPPORT	HALTER
72	12792611/0	2	VITE	SCREW	VIS	SCHRAUBE
73	12293201/0	2	DADO	NUT	ECROU	MUTTER
74	22672151/0	1	RONDELLA	WASHER	RONDELLE	SCHEIBE
75	82774204/1	1	STAFFA	CLAMP	BRIDE	BRIDE
76	82318135/0	1	LEVA	LEVER	LEVIER	HEBEL
77	25430227/0	1	MOLLA	SPRING	RESSORT	FEDER
78	12692050/0	1	VITE	SCREW	VIS	SCHRAUBE
79	12155000/0	1	DADO	NUT	ECROU	MUTTER
80	22061337/0	1	CAVALLOTTO	CONNECTING PLATE	PAQUE DE CONNEXION	BUGEL BOLZEN
81	12791213/1	1	VITE	SCREW	VIS	SCHRAUBE
82	12154510/0	1	DADO	NUT	ECROU	MUTTER
83	12523060/0	1	RONDELLA	WASHER	RONDELLE	SCHEIBE
84	12155010/0	1	DADO	NUT	ECROU	MUTTER
85	82004604/3	1	FILO	WIRE	FIL	KABEL
86	12523060/0	1	RONDELLA	WASHER	RONDELLE	SCHEIBE
87	25394510/0	1	MANOPOLA	KNOB	POIGNEE	GRIFF

www.emc-motoculture.com

J JP JT JR JTP JB JX

92

92 hydro

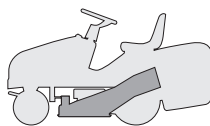

PIATTO DI TAGLIO (2)
CUTTING PLATE (2)
PLATEAU DE COUPE (2)
SCHNEIDWERKZEUG (2)

2004

009.0

1 / 2

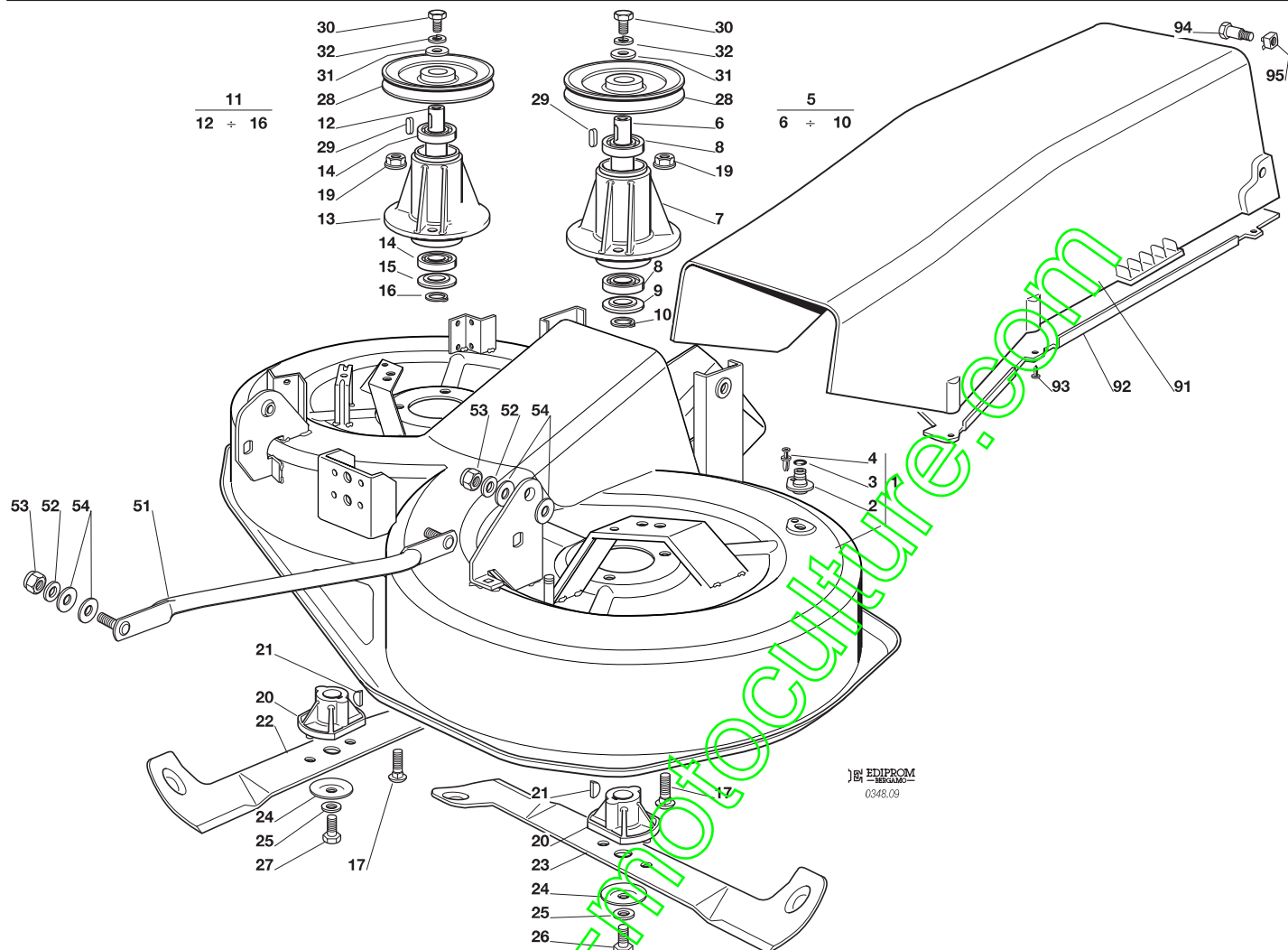

EDIPROM
0348.09

N.	CODE	Q.TY	DESCRIZIONE	DESCRIPTION	DESCRIPTION	BESCHREIBUNG
1	82564034/1	1	PIATTO	PLATE	PLATEAU	SCHNEID
2	25033060/0	2	ATTACCO	WATER HOSE CONNECTION	RACCORD TUYAU D'EAU	WASSERANSCHLUSS
3	19035000/0	2	ANELLO OR	O RING	O RING	O RING
4	12500030/0	2	RIVETTO	RIVET	RIVET	NIET
5	82207202/0	1	ASS. FLANGIA SINISTRA (6÷10)	LEFT FLANGE ASS.Y (6÷10)	ENS. BRIDE GAUCHE (6÷10)	LINKE NABE, KOMPLETT (6÷10)
6	25020802/0	1	ALBERO	SHAFT	ARBRE	WELLE
7	25207200/0	1	FLANGIA	FLANGE	BRIDE	FLANSCH
8	19216032/0	2	CUSCINETTO	BEARING	ROULEMENT	KUEGELLAGER
9	25160501/0	1	DISCO PARAPOLVERE	DUST COVER	PROTEGE-POUSSIÈRE	STAUBSCHUTTSCHIEBE
10	12609260/0	1	SEEGER	SEEGER	SEEGER	SEEGER
11	82207203/0	1	ASS. FLANGIA DESTRA (12÷16)	RIGHT FLANGE ASS.Y (12÷16)	ENS. BRIDE DROITE (12÷16)	RECHTE NABE, KOMPLETT (12÷16)
12	25020803/0	1	ALBERO	SHAFT	ARBRE	WELLE
13	25207200/0	1	FLANGIA	FLANGE	BRIDE	FLANSCH
14	19216032/0	2	CUSCINETTO	BEARING	ROULEMENT	KÜGELLAGER
15	25160501/0	1	DISCO PARAPOLVERE	DUST COVER	PROTEGE-POUSSIÈRE	STAUBSCHUTTSCHIEBE
16	12609260/0	1	SEEGER	SEEGER	SEEGER	SEEGER
17	12818700/0	6	VITE	SCREW	VIS	SCHRAUBE
19	12154210/0	6	DADO	NUT	ECROU	MUTTER
20	25463200/0	2	MOZZO COLTELLO	BLADE HUB	MOYEU LAME	MESSERHALTER
21	12139100/0	2	LINGUETTA	KEY	CLAVETTE	KEIL
22	82004345/1	1	COLTELLO DESTRO	RIGHT BLADE	LAME DROITE	RECHTER MESSER
23	82004344/1	1	COLTELLO SINISTRO	LEFT BLADE	LAME GAUCHE	LINKER MESSER
24	22160400/0	2	DISCO PARAPOLVERE	DUST COVER	PROTEGE-POUSSIÈRE	STAUBSCHUTTSCHIEBE
25	12523080/0	2	RONDELLA	WASHER	RONDELLE	SCHIEBE
26	12735694/0	1	VITE	SCREW	VIS	SCHRAUBE
27	12735695/1	1	VITE	SCREW	VIS	SCHRAUBE
28	25601573/0	2	PULEGGIA	PULLEY	POULIE	RIEMENSCHIEBE
29	12139480/0	2	CHIAVETTA	KEY	CLAVETTE	KEIL
30	12793102/0	2	VITE	SCREW	VIS	SCHRAUBE





N.	CODE	Q.TY	DESCRIZIONE	DESCRIPTION	DESCRIPTION	BESCHREIBUNG
31	25670007/0	2	RONDELLA	WASHER	RONDELLE	SCHEIBE
32	12583500/0	2	GROWER	GROWER	GROWER	GROWER
—	82564050/0	1	PIATTO DI TAGLIO ASSEMBLATO (008, 1÷39 + 49÷54 + 009, 1÷32)	CUTTING PLATE, ASSEMBLED (008, 1÷39 + 49÷54 + 009, 1÷32)	PLATEAU DE COUPE, COMPLETE (008, 1÷39 + 49÷54 + 009, 1÷32)	SCHNEIDWERKZEUG, KOMPLETT (008, 1÷39 + 49÷54 + 009, 1÷32)
51	82000474/1	2	ASTA BILANCIERE	EQUALIZER ROD	TIGE BALANCIER	KIPPEBEL
52	12521360/0	4	RONDELLA	WASHER	RONDELLE	SCHEIBE
53	12156602/0	4	DADO	NUT	ECROU	MUTTER
54	25670008/1	8	RONDELLA	WASHER	RONDELLE	SCHEIBE
91	25108004/0	1	CONVOGLIATORE	CONVEYOR	CONVOYEUR	BLECHSATZ
92	25190091/0	1	DEFLETTORE	DEFLECTOR	DEFLECTEUR	ABWEISER
93	12735402/0	6	VITE	SCREW	VIS	SCHRAUBE
94	25510061/0	2	PERNO	PIN	PIVOT	BOLZEN
95	12360430/0	2	DADO	NUT	ECROU	MUTTER

www.emc-motoculture.com

J

JP

JT

JR

JTP

JB

JX

92

92 hydro

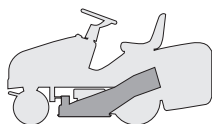

PIATTO DI TAGLIO (2)
CUTTING PLATE (2)
PLATEAU DE COUPE (2)
SCHNEIDWERKZEUG (2)

2004

009a.0

1 / 2

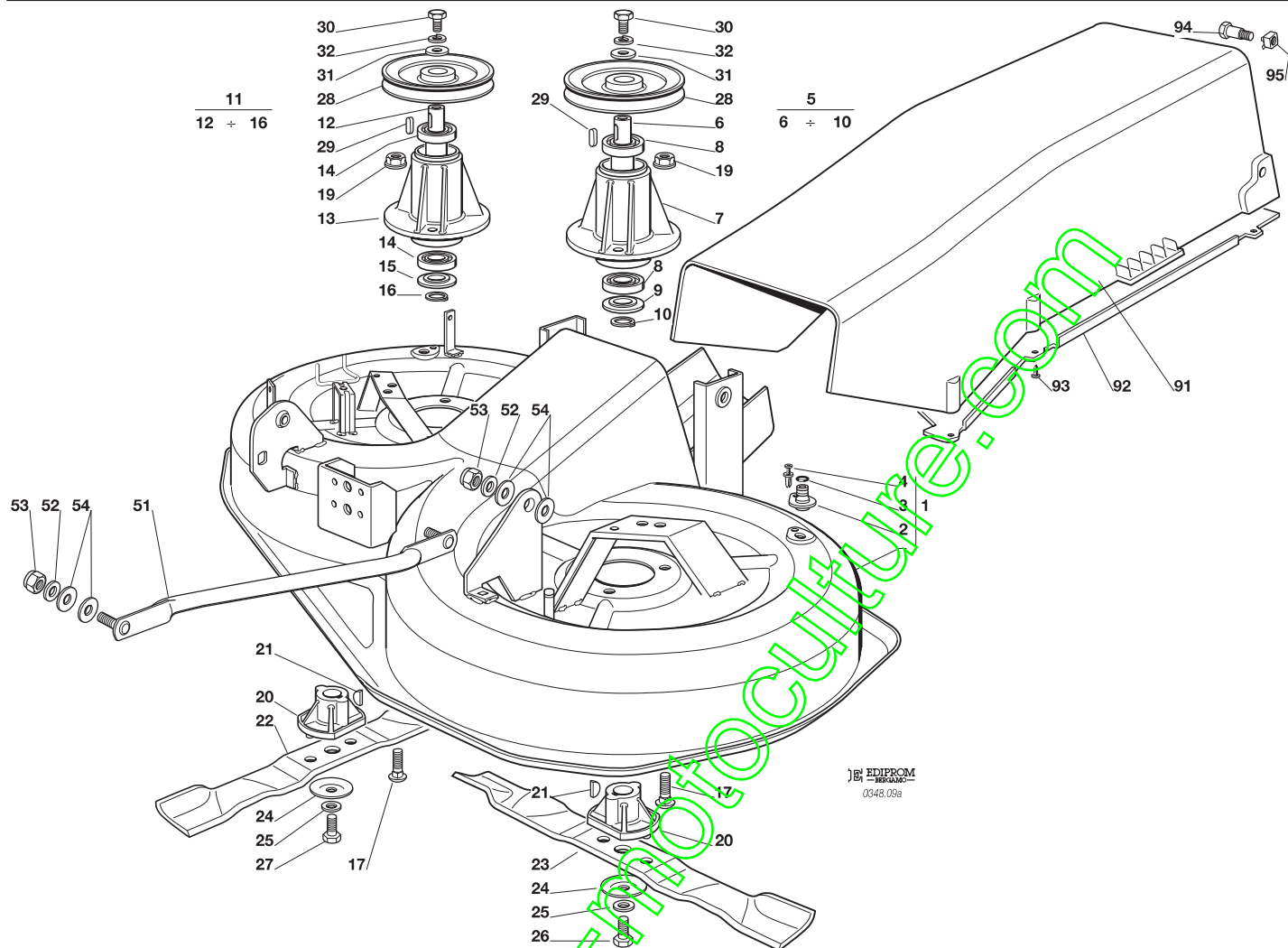

EDIPROM
0348.09a

N.	CODE	Q.TY	DESCRIZIONE	DESCRIPTION	DESCRIPTION	BESCHREIBUNG
1	82564048/0	1	PIATTO	PLATE	PLATEAU	SCHNEID
2	25033060/0	2	ATTACCO	WATER HOSE CONNECTION	RACCORD TUYAU D'EAU	WASSERANSCHLUSS
3	19035000/0	2	ANELLO OR	O RING	O RING	O RING
4	12500030/0	2	RIVETTO	RIVET	RIVET	NIET
5	82207202/0	1	ASS. FLANGIA SINISTRA (6÷10)	LEFT FLANGE ASS.Y (6÷10)	ENS. BRIDE GAUCHE (6÷10)	LINKE NABE, KOMPLETT (6÷10)
6	25020802/0	1	ALBERO	SHAFT	ARBRE	WELLE
7	25207200/0	1	FLANGIA	FLANGE	BRIDE	FLANSCH
8	19216032/0	2	CUSCINETTO	BEARING	ROULEMENT	KUEGELLAGER
9	25160501/0	1	DISCO PARAPOLVERE	DUST COVER	PROTEGE-POUSSIÈRE	STAUBSCHUTTSCHIEBE
10	12609260/0	1	SEEGER	SEEGER	SEEGER	SEEGER
11	82207203/0	1	ASS. FLANGIA DESTRA (12÷16)	RIGHT FLANGE ASS.Y (12÷16)	ENS. BRIDE DROITE (12÷16)	RECHTE NABE, KOMPLETT (12÷16)
12	25020803/0	1	ALBERO	SHAFT	ARBRE	WELLE
13	25207200/0	1	FLANGIA	FLANGE	BRIDE	FLANSCH
14	19216032/0	2	CUSCINETTO	BEARING	ROULEMENT	KÜGELLAGER
15	25160501/0	1	DISCO PARAPOLVERE	DUST COVER	PROTEGE-POUSSIÈRE	STAUBSCHUTTSCHIEBE
16	12609260/0	1	SEEGER	SEEGER	SEEGER	SEEGER
17	12818700/0	6	VITE	SCREW	VIS	SCHRAUBE
19	12154210/0	6	DADO	NUT	ECROU	MUTTER
20	25463200/0	2	MOZZO COLTELLO	BLADE HUB	MOYEU LAME	MESSERHALTER
21	12139100/0	2	LINGUETTA	KEY	CLAVETTE	KEIL
22	82004352/0	1	COLTELLO DESTRO MULCHING	RIGHT BLADE MULCHING	LAME DROITE MULCHING	RECHTER MESSER MULCHING
	82004354/0	1	COLTELLO DESTRO MULCHING, ALETTATO	RIGHT BLADE MULCHING, WINGED	LAME DROITE MULCHING, AILLETTEE	RECHTER MESSER MULCHING, FLÜGEL
23	81004346/3	1	COLTELLO SINISTRO MULCHING	LEFT BLADE MULCHING	LAME GAUCHE MULCHING	LINKER MESSER MULCHING
	82004353/0	1	COLTELLO SINISTRO MULCHING, ALETTATO	LEFT BLADE MULCHING, WINGED	LAME GAUCHE MULCHING, AILLETTEE	LINKER MESSER MULCHING, FLÜGEL
24	22160400/0	2	DISCO PARAPOLVERE	DUST COVER	PROTEGE-POUSSIÈRE	STAUBSCHUTTSCHIEBE





N.	CODE	Q.TY	DESCRIZIONE	DESCRIPTION	DESCRIPTION	BESCHREIBUNG
25	12523080/0	2	RONDELLA	WASHER	RONDELLE	SCHEIBE
26	12735694/0	1	VITE	SCREW	VIS	SCHRAUBE
27	12735695/1	1	VITE	SCREW	VIS	SCHRAUBE
28	25601573/0	2	PULEGGIA	PULLEY	POULIE	RIEMENSCHLEIBE
29	12139480/0	2	CHIAVETTA	KEY	CLAVETTE	KEIL
30	12793102/0	2	VITE	SCREW	VIS	SCHRAUBE
31	25670007/0	2	RONDELLA	WASHER	RONDELLE	SCHEIBE
32	12583500/0	2	GROWER	GROWER	GROWER	GROWER
—	82564049/0	1	PIATTO DI TAGLIO ASSEMBLATO (008, 1÷39 + 49÷54 + 009a, 1÷32)	CUTTING PLATE, ASSEMBLED (008, 1÷39 + 49÷54 + 009a, 1÷32)	PLATEAU DE COUPE, COMPLETE (008, 1÷39 + 49÷54 + 009a, 1÷32)	SCHNEIDWERKZEUG, KOMPLETT (008, 1÷39 + 49÷54 + 009a, 1÷32)
51	82000474/1	2	ASTA BILANCIERE	EQUALIZER ROD	TIGE BALANCIER	KIPPEBEL
52	12521360/0	4	RONDELLA	WASHER	RONDELLE	SCHEIBE
53	12156602/0	4	DADO	NUT	ECROU	MUTTER
54	25670008/1	8	RONDELLA	WASHER	RONDELLE	SCHEIBE
91	25108004/0	1	CONVOGLIATORE	CONVEYOR	CONVOYEUR	BLECHSATZ
92	25190091/0	1	DEFLETTORE	DEFLECTOR	DEFLECTEUR	ABWEISER
93	12735402/0	6	VITE	SCREW	VIS	SCHRAUBE
94	25510061/0	2	PERNO	PIN	PIVOT	BOLZEN
95	12360430/0	2	DADO	NUT	ECROU	MUTTER

www.emc-motoculture.com

J	JP	JT	JR	JTP	JB	JX
---	----	----	----	-----	----	----

92

92 hydro

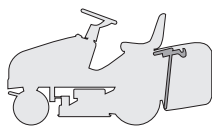

SACCO (1. - PARTE FISSA)
GRASSCATCHER (1. - FIXED PART)
BAC (1. - PARTIE FIXE)
AUFFANGSACK (1. - FESTER TEIL)

2004

010.0

1 / 1

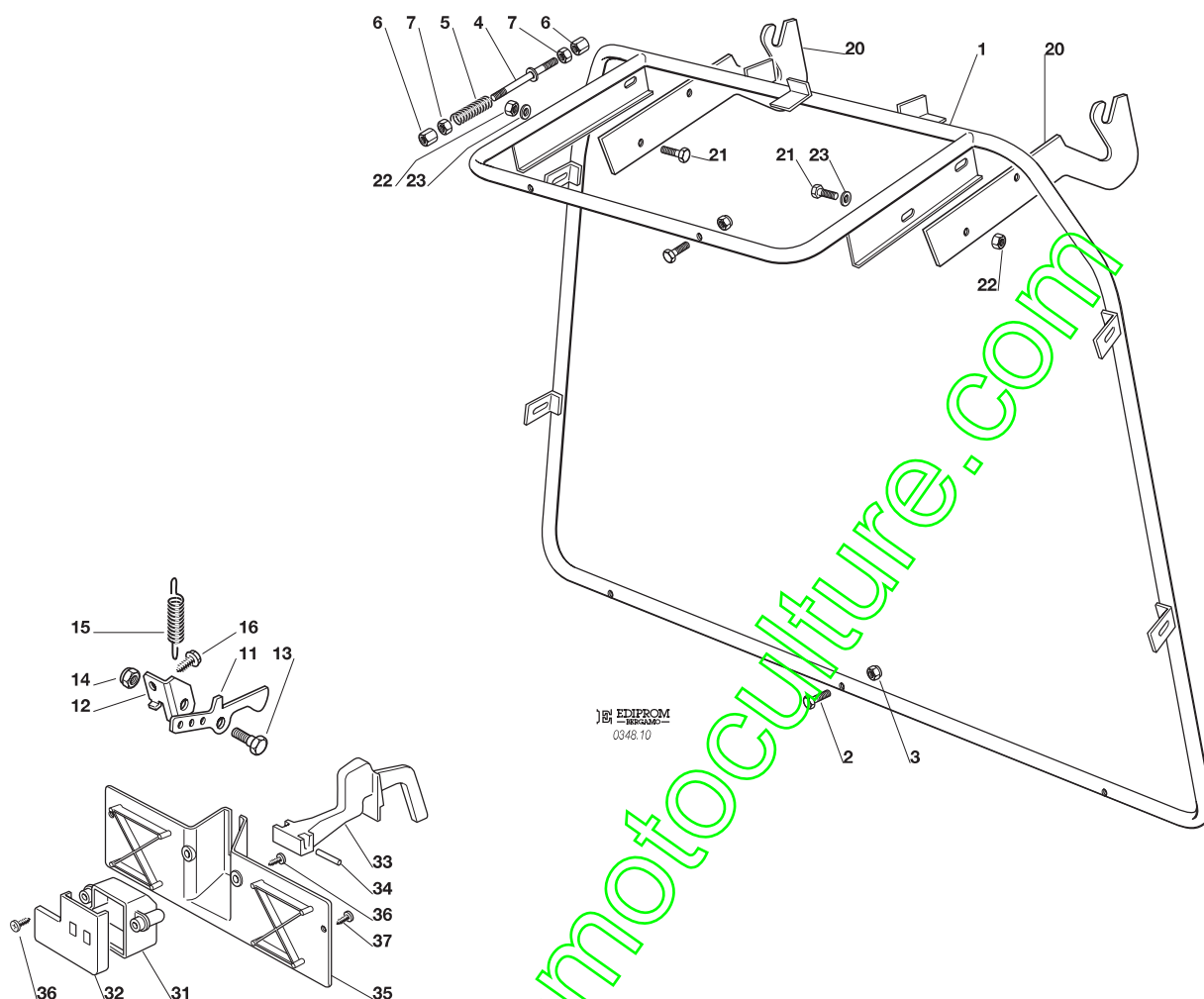

N.	CODE	Q.TY	DESCRIZIONE	DESCRIPTION	DESCRIPTION	BESCHREIBUNG
1	82800017/1	1	TELAIO	FRAME	CHASSIS	RAHMEN
2	12791500/0	5	VITE	SCREW	VIS	SCHRAUBE
3	12154510/0	5	DADO	NUT	ECROU	MUTTER
4	82000465/1	1	ASTA	ROD	TIGE	STANGE
5	25430232/0	1	MOLLA	SPRING	RESSORT	FEDER
6	25510042/0	2	PERNO	PIN	PIVOT	BOLZEN
7	12292100/0	2	DADO	NUT	ECROU	MUTTER
11	25774327/0	1	STAFFA	BRACKET	ETRIER	BRIDE
12	25755031/0	1	SQUADRETTA	BRACKET	EQUERRE-SUPPORT	WINKEL
13	25510080/0	1	PERNO	PIN	PIVOT	BOLZEN
14	12292102/0	1	DADO	NUT	ECROU	MUTTER
15	25430220/0	1	MOLLA	SPRING	RESSORT	FEDER
16	12735122/0	1	VITE	SCREW	VIS	SCHRAUBE
20	25785077/0	2	SUPPORTO	SUPPORT	SUPPORT	HALTER
21	12793102/0	4	VITE	SCREW	VIS	SCHRAUBE
22	12155000/0	4	DADO	NUT	ECROU	MUTTER
23	12521350/0	4	RONDELLA	WASHER	RONDELLE	SCHEIBE
31	25600041/0	1	PROTEZIONE MICRO	MICRO PROTECTION	PROTECTION MICRO	SCHUTZ
32	25600042/0	1	COPERCHIO PROTEZIONE	PROTECTION COVER	COUVERCLE PROTECTION	SCHUTZDEKEL
33	25318124/0	1	LEVA	LEVER	LEVIER	HEBEL
34	12400030/0	1	PERNO	PIN	PIVOT	BOLZEN
35	25774251/0	1	STAFFA	BRACKET	SUPPORT	SHELLE
36	12728510/0	3	VITE	SCREW	VIS	SCHRAUBE
37	12735110/0	2	VITE	SCREW	VIS	SCHRAUBE

J

JP

JT

JR

JTP

JB

JX

92

92 hydro

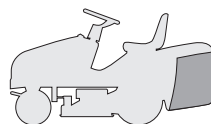

SACCO (2. - PARTE MOBILE)
GRASSCATCHER (2. - MOBILE PART)
BAC (2. - PARTIE MOBILE)
AUFFANGSACK (2. - BEWEGLICHER TEIL)

2004

011.0

1 / 1

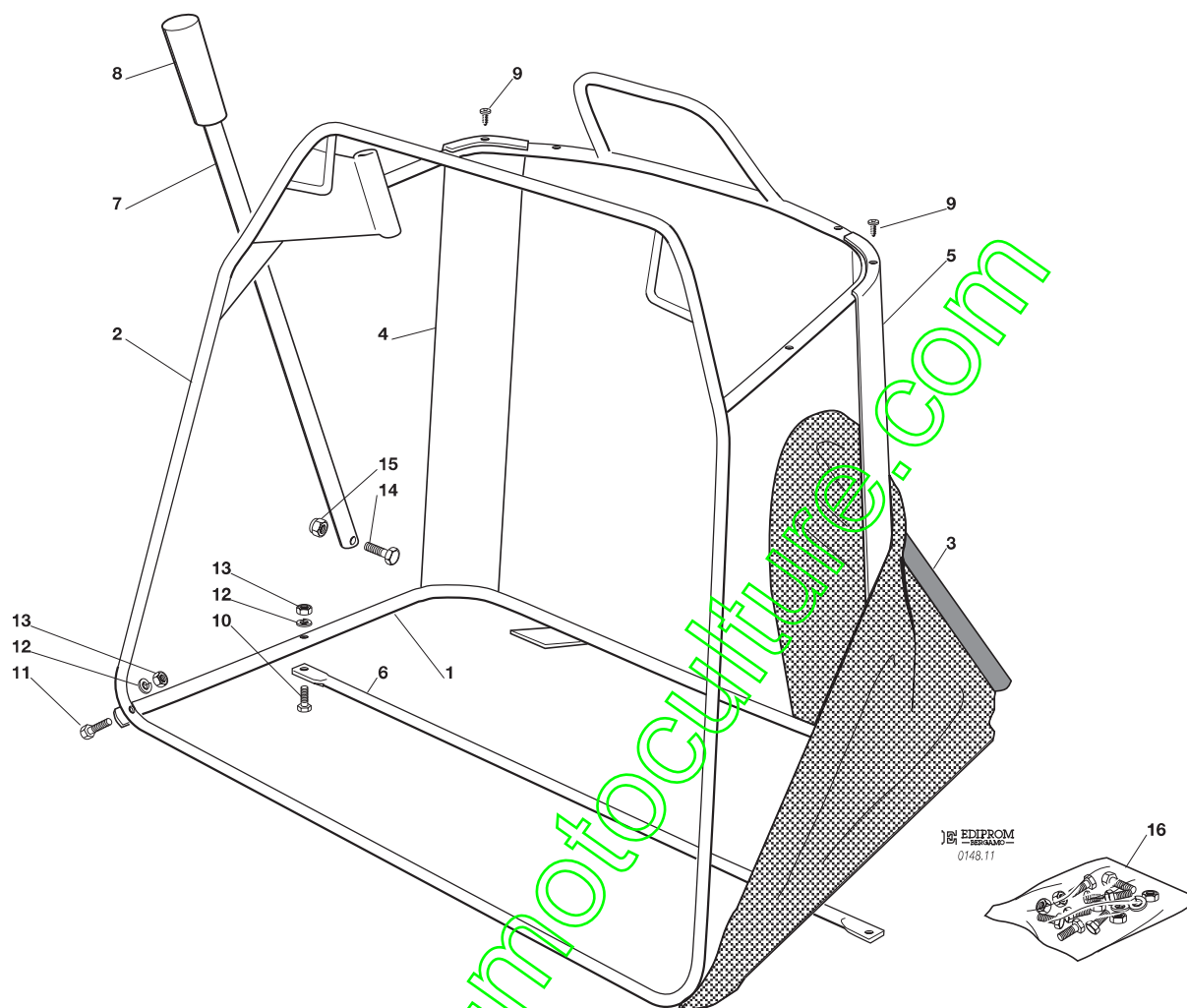

N.	CODE	Q.TY	DESCRIZIONE	DESCRIPTION	DESCRIPTION	BESCHREIBUNG
1	82800015/0	1	TELAIO INFERIORE	LOWER FRAME	CHASSIS INFERIEUR	UNTERERRAHMEN
2	82800014/1	1	TELAIO SUPERIORE	UPPER FRAME	CHASSIS SUPERIEUR	OBERERRAHMEN
3	82105998/0	1	CONFEZIONE SACCO	GRASSCATCHER	BAC	SACK
4	25032005/0	1	ANGOLARE DESTRO	RIGHT ANGULAR SUPPORT	SUPPORT ANGULAIRE DROITE	RECHTER HALTER
5	25032004/0	1	ANGOLARE SINISTRO	LEFT ANGULAR SUPPORT	SUPPORT ANGULAIRE GAUCHE	LINKER HALTER
6	82650039/0	1	RINFORZO	STIFFENING	RENFORCEMENT	VERSTAERKUNG
7	25869029/1	1	TUBO	ROD	TIGE	STANGE
8	25394508/0	1	MANOPOLA	HANDLE	POINGEE	GRIF
9	12729601/1	4	VITE	SCREW	VIS	SCHRAUBE
10	12792099/0	2	VITE	SCREW	VIS	SCHRAUBE
11	12792099/0	2	VITE	SCREW	VIS	SCHRAUBE
12	12582101/0	4	GROWER	GROWER	GROWER	GROWER
13	12292100/0	4	DADO	NUT	ECROU	MUTTER
14	12792099/0	1	VITE	SCREW	VIS	SCHRAUBE
15	12154510/0	1	DADO	NUT	ECROU	MUTTER
16	82180016/1	1	DOTAZIONE VITERIA (9÷15)	SCREWS OUTFIT (9÷15)	ENSEMBLE DES VIS (9÷15)	SCHRAUBENAUSRÜSTUNG (9÷15)

J	JP	JT	JR	JTP	JB	JX
---	----	----	----	-----	----	----

92

92 hydro

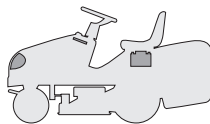

PARTI ELETTRICHE
ELECTRICAL PARTS
PARTIES ELECTRIQUES
ELETRISCHETEILE
B&S - TECUMSEH

2004

012.0

1 / 2

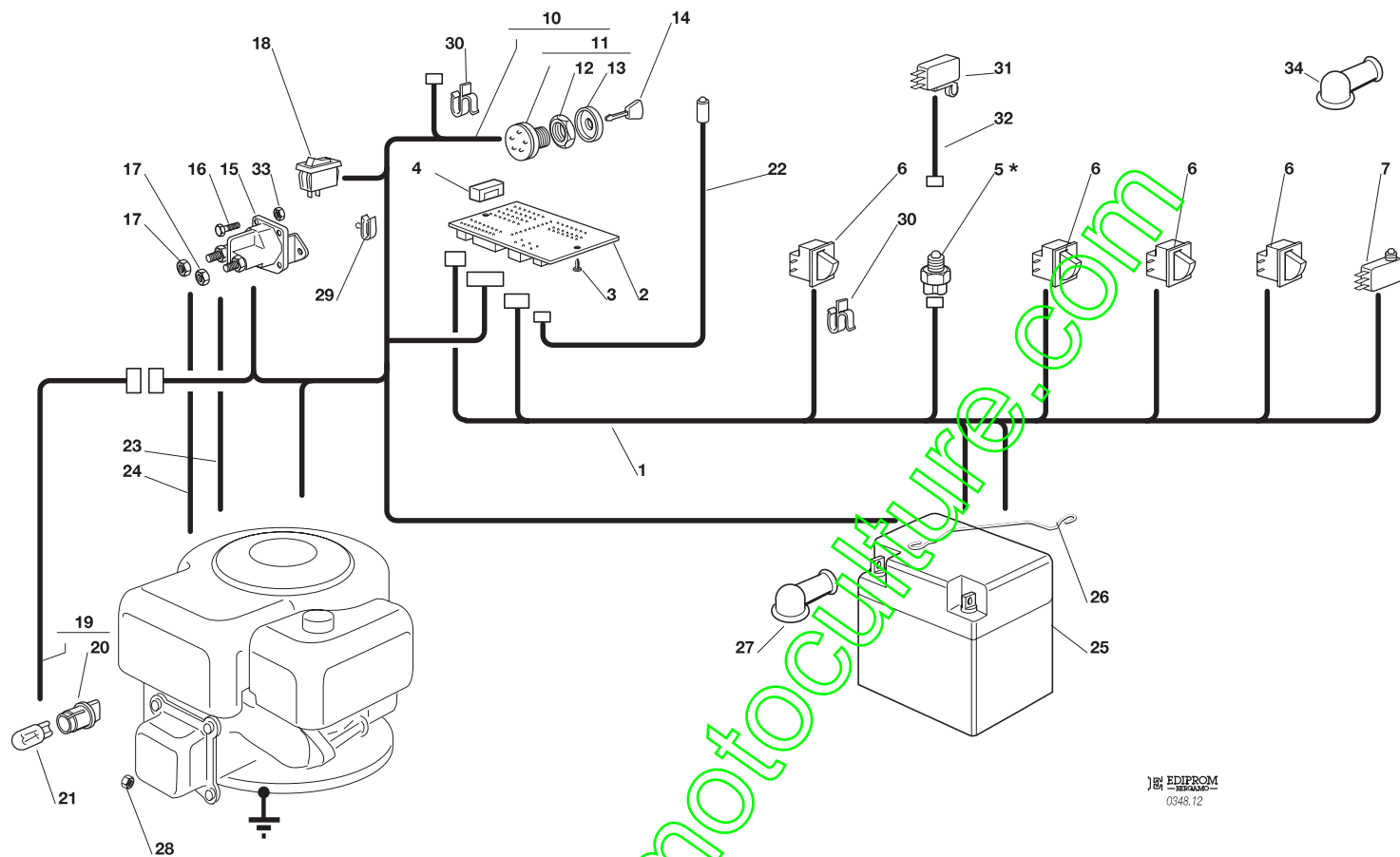

EDIPROM
REPARAZIONE
0348.12

N.	CODE	Q.TY	DESCRIZIONE	DESCRIPTION	DESCRIPTION	BESCHREIBUNG
1	82040105/0	1	CABLAGGIO POSTERIORE	CABLES ASS.Y	ENS. CABLAGES	KABELSATZ
2	25722415/0	1	SCHEDA ELETTRONICA	ELECTRONIC CARD	CARTE ELECTRONIQUE	ELEKTRONISCHE KARTE
3	12727810/0	2	VITE	SCREW	VIS	SCHRAUBE
4	33340033/0	1	FUSIBILE	FUSE	FUSIBLE	SICHERUNG
5*	-	1	INTERRUTT. CAMBIO (mecc.)	GEARBOX SWITCH (mech.)	INT. BOÎTE DE VITESSE (mec.)	ANTRIEB SCHALTER (mech.)
6	19410606/0	4	MICRO INTERRUTTORE	MICROSWITCH	MICROINTERRUPTEUR	MIKROSCHALTER
7	19410605/1	1	MICRO SACCO PIENO	FULL GRASSCATCHER	MICRO BAC PLEIN	VOLLKORB VORRICHTUNG
10	82040082/2	1	CABLAGGIO ANTERIORE	CABLES ASS.Y	ENS. CABLAGES	KABELSATZ
10	82040117/0	1	CABLAGGIO ANTERIORE 15 - 15,5 HP B&S	CABLES ASS.Y 15 - 15,5 HP B&S	ENS. CABLAGES 15 - 15,5 HP B&S	KABELSATZ 15 - 15,5 HP B&S
11	18450065/1	1	INTERRUTTORE AVVIA.M.	STARTING SWITCH	INTERRUPTEUR DEMARR.	SCHALTER
12	18400861/0	1	GHIERA	RINGNUT	EMBOU	NUTMUTTER
13	18565351/0	1	PROTEZIONE GHIERA	RINGNUT PROTECTION	PROTECTION EMBOUT	NUTMUTTER SCHUTZ
14	18210016/0	1	CHIAVE AVVIAMENTO	STARTING KEY	CLEF A DEMARRAGE	SCHLÜSSEL FÜR START
15	18736111/0	1	RELÉ AVVIAMENTO	STARTER RELAY	RELAIS D'ALLUMAGE	ANLASSRELAIS
16	12791213/1	2	VITE	SCREW	VIS	SCHRAUBE
17	12360352/0	2	DADO	NUT	ECROU	MUTTER
18	18450060/1	1	INTERRUTTORE	FARILAMP SWITCH	INTERRUPTEUR PHARES	LICHTEN SCHALTER
19	82040070/0	1	CAVO FARI	CABLE	CABLES	KABEL
19	82040073/0	1	CAVO FARI (JX)	CABLE (JX)	CABLES (JX)	KABEL (JX)
20	33500030/0	2	PORTALAMPADE	LAMP HOLDER	DOUILLE DE LAMPE	SCHWEINWERFERLAMPE
21	18459100/0	2	LAMPADA	FARILAMP FOR LIGHTS	LAMPE POUR PHARES	LAMPENFASSUN
22	25065014/1	1	CAVO LED SEGNALEZIONE	CABLE	CABLES	KABEL
23	25065012/0	1	CAVO RICARICA	CABLE	CABLES	KABEL
24	25065017/0	1	CABLAGGIO SOLEN. AV.	CABLES ASS.Y	ENS. CABLAGES	KABELSATZ
25	18120002/1	1	BATTERIA	BATTERY	BATTERIE	BATTERIE
26	25430230/0	1	MOLLA	SPRING	RESSORT	FEDER
27	18564861/1	1	CAPPUCCIO	PROTECTION	CAPUCHON	STECKER
28	12361005/0	1	DADO	NUT	ECROU	MUTTER
29	33320506/0	4	FERMACAVO	FAIRLED	FIXATION CABLE	KABELBEFESTIGUNG
30	33320504/0	1	FERMACAVO	FAIRLED	FIXATION CABLE	KABELBEFESTIGUNG





N.	CODE	Q.TY	DESCRIZIONE	DESCRIPTION	DESCRIPTION	BESCHREIBUNG
31	19410609/0	1	INTERRUTT. FOLLE <i>(hydro)</i>	MICROSWITCH <i>(hydro)</i>	MICROINTERRUPTEUR <i>(hydro)</i>	MIKROSCHALTER <i>(hydro)</i>
32	25065025/0	1	CAVO MICRO FOLLE <i>(hydro)</i>	CABLE <i>(hydro)</i>	CABLES <i>(hydro)</i>	KABEL <i>(hydro)</i>
33	12292102/0	2	DADO	NUT	ECROU	MUTTER
34	18564864/1	1	CAPPUCCIO	PROTECTION	CAPUCHON	STECKER

PER LA SOSTITUZIONE DELLE PARTI CONTRASSEGNAE CON «*» RIVOLGERSI AL SERVIZIO ASSISTENZA DEL COSTRUTTORE DELLA TRASMISSIONE.
 TO REPLACE THE PARTS MARKED «*» SEEK ASSISTANCE FROM THE TRANSMISSION MANUFACTURER'S AFTER SALES SERVICE.
 POUR LE REMPLACEMENT DES PIÈCES MARQUÉES AVEC «*» S'ADRESSER AU SERVICE APRÈS VENTES DU CONSTRUCTEUR DE LA TRANSMISSION.
 ZUM AUSTAUSCH DER MIT «*» GEKENNZEICHNETEN TEILE, WENDEN SIE SICH AN DEN KUNDENDIENST DES HERSTELLERS DES ANTRIEBS.

www.emc-motoculture.com

J	JP	JT	JR	JTP	JB	JX
---	----	----	----	-----	----	----

92

92 hydro

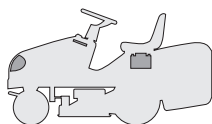

PARTI ELETTRICHE
ELECTRICAL PARTS
PARTIES ELECTRIQUES
ELETRISCHETEILE
HONDA

2004

012a.0

1 / 2

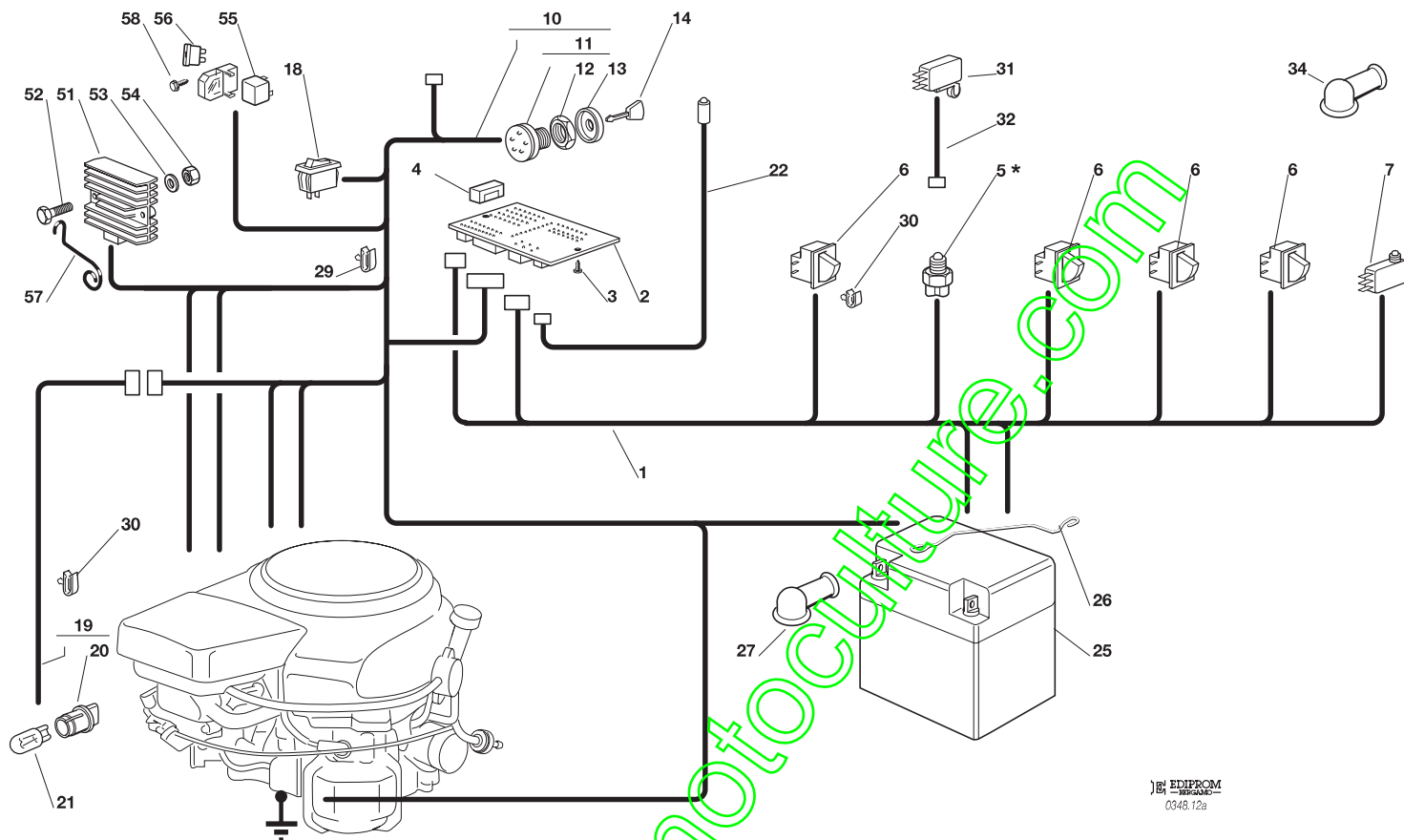

EDIPROM
0346.12a

N.	CODE	Q.TY	DESCRIZIONE	DESCRIPTION	DESCRIPTION	BESCHREIBUNG
1	82040107/0	1	CABLAGGIO POSTERIORE	CABLES ASS.Y	ENS. CABLAGES	KABELSATZ
2	25722415/0	1	SCHEDA ELETTRONICA	ELECTRONIC CARD	CARTE ELECTRONIQUE	ELEKTRONISCHE KARTE
3	12727810/0	2	VITE	SCREW	VIS	SCHRAUBE
4	33340033/0	1	FUSIBILE	FUSE	FUSIBLE	SICHERUNG
5*	-	1	INTERRUTT. CAMBIO (mecc.)	GEARBOX SWITCH (mech.)	INT. BOÎTE DE VITESSE (mec.)	ANTRIEB SCHALTER (mech.)
6	19410606/0	4	MICRO INTERRUTTORE	MICROSWITCH	MICROINTERRUPTEUR	MIKROSCHALTER
7	19410605/1	1	MICRO SACCO PIENO	FULL GRASSCATCHER	MICRO BAC PLEIN	VOLLKORB VORRICHTUNG
10	82040084/0	1	CABLAGGIO ANTERIORE	CABLES ASS.Y	ENS. CABLAGES	KABELSATZ
11	18450065/1	1	INTERRUTTORE AVVIAM.	STARTING SWITCH	INTERRUPTEUR DEMARR.	SCHALTER
12	18400861/0	1	GHIERA	RINGNUT	EMBOUT	NUTMUTTER
13	18565351/0	1	PROTEZIONE GHIERA	RINGNUT PROTECTION	PROTECTION EMBOUT	NUTMUTTER SCHUTZ
14	18210016/0	1	CHIAVE AVVIAMENTO	STARTING KEY	CLEF A DEMARRAGE	SCHLÜSSEL FÜR START
18	18450060/1	1	INTERRUTTORE	FARILAMP SWITCH	INTERRUPTEUR PHARES	LICHTEN SCHALTER
19	82040070/0	1	CAVO FARIL	CABLE	CABLES	KABEL
19	82040073/0	1	CAVO FARIL (JX)	CABLE (JX)	CABLES (JX)	KABEL (JX)
20	33500030/0	2	PORTALAMPADE	LAMP HOLDER	DOUILLE DE LAMPE	SCHENWERFERLAMPE
21	18459100/0	2	LAMPADA	FARILAMP FOR LIGHTS	LAUPE POUR PHARES	LAMPENFASSUN
22	25065014/1	1	CAVO LED SEGNALEZIONE	CABLE	CABLES	KABEL
25	18120002/1	1	BATTERIA	BATTERY	BATTERIE	BATTERIE
26	25430230/0	1	MOLLA	SPRING	RESSORT	FEDER
27	18564861/1	1	CAPPUCCIO	PROTECTION	CAPUCHON	STECKER
29	33320506/0	4	FERMACAVO	FAIRLED	FIXATION CABLE	KABELBEFESTIGUNG
30	33320504/0	1	FERMACAVO	FAIRLED	FIXATION CABLE	KABELBEFESTIGUNG
31	19410609/0	1	INTERRUTT. FOLLE (hydro)	MICROSWITCH (hydro)	MICROINTERRUPTEUR (hydro)	MIKROSCHALTER (hydro)
32	25065025/0	1	CAVO MICRO FOLLE (hydro)	CABLE (hydro)	CABLES (hydro)	KABEL (hydro)
34	18564864/1	1	CAPPUCCIO	PROTECTION	CAPUCHON	STECKER
51♦	-	1	RELÉ AVVIAMENTO	STARTER RELAY	RELAIS D'ALLUMAGE	ANLASSRELAIS





N.	CODE	Q.TY	DESCRIZIONE	DESCRIPTION	DESCRIPTION	BESCHREIBUNG
52	12727793/0	2	VITE	SCREW	VIS	SCHRAUBE
53	12551330/0	2	RONDELLA	WASHER	RONDELLE	SCHEIBE
54	12154510/0	2	DADO	NUT	ECROU	MUTTER
55	33215000/0	1	RELÉ	RELAY	RELAIS	RELAIS
56	33340035/0	1	FUSIBILE 15A	FUSE 15A	FUSIBLE 15A	SICHERUNG 15A
57	27430561/0	1	MOLLA	SPRING	RESSORT	FEDER
58	12735170/0	1	VITE	SCREW	VIS	SCHRAUBE

PER LA SOSTITUZIONE DELLE PARTI CONTRASSEGNALE CON «*» RIVOLGERSI AL SERVIZIO ASSISTENZA DEL COSTRUTTORE DELLA TRASMISSIONE.
 TO REPLACE THE PARTS MARKED «*» SEEK ASSISTANCE FROM THE TRANSMISSION MANUFACTURER'S AFTER SALES SERVICE.
 POUR LE REMPLACEMENT DES PIÈCES MARQUÉES AVEC «*» S'ADRESSER AU SERVICE APRÈS VENTES DU CONSTRUCTEUR DE LA TRANSMISSION.
 ZUM AUSTAUSCH DER MIT «*» GEKENNZEICHNETEN TEILE, WENDEN SIE SICH AN DEN KUNDENDIENST DES HERSTELLERS DES ANTRIEBS.

PER LA SOSTITUZIONE DELLE PARTI CONTRASSEGNALE CON «◆» RIVOLGERSI AL SERVIZIO ASSISTENZA DEL COSTRUTTORE DEL MOTORE.
 TO REPLACE THE PARTS MARKED «◆» SEEK ASSISTANCE FROM THE ENGINE MANUFACTURER'S AFTER SALES SERVICE.
 POUR LE REMPLACEMENT DES PIÈCES MARQUÉES AVEC «◆» S'ADRESSER AU SERVICE APRÈS VENTES DU CONSTRUCTEUR DU MOTEUR.
 ZUM AUSTAUSCH DER MIT «◆» GEKENNZEICHNETEN TEILE, WENDEN SIE SICH AN DEN KUNDENDIENST DES HERSTELLERS DES MOTOR.

www.emc-motoculture.com

J JP JT JR JTP JB JX

92

92 hydro

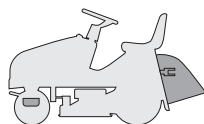

ACCESSORI A RICHIESTA
 OPTIONALS ON REQUEST
 ACCESSOIRES SUR DEMANDE
 ZUBEHOERE NACH ANFRAGE

2004

013.0

1 / 2

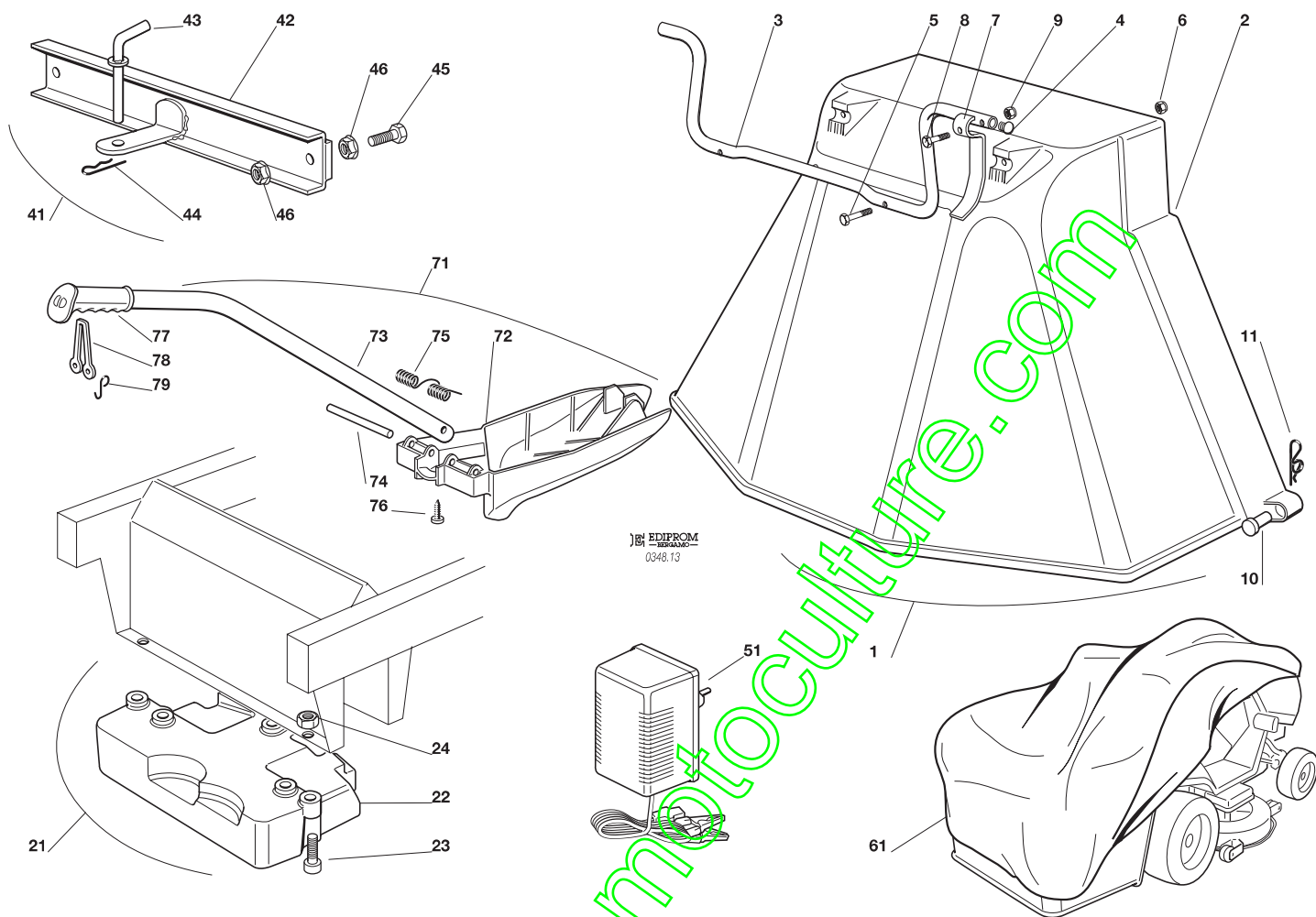

N.	CODE	Q.TY	DESCRIZIONE	DESCRIPTION	DESCRIPTION	BESCHREIBUNG
1	99900050/0	1	KIT PROTEZIONE USCITA	EJECTION GUARD KIT	KIT PROTECTION SORTIE	AUSWURFSCHUTZVORRICHTUNG
2	82400002/0	1	PROTEZIONE USCITA	EJECTION GUARD	PROTECTION SORTIE	AUSWURFSCHUTZ
3	25869031/0	1	TUBO DI AGGANCIAMENTO	SUPPORT	SOPPORT	HALTER
4	18566113/0	2	PUNTALE	CAP	BOUCHON	PFROPFEN
5	12674701/0	2	VITE	SCREW	VIS	SCHRAUBE
6	12154510/0	2	DADO	NUT	ECROU	MUTTER
7	25547053/0	1	PIASTRINA	PLATE	PLAQUETTE	PLÄTTCHEN
8	12791500/0	1	VITE	SCREW	VIS	SCHRAUBE
9	12154510/0	1	DADO	NUT	ECROU	MUTTER
10	25510022/0	2	PERNO	PIN	PIVOT	BOLZEN
11	24487998/0	2	COPPIGLIA	COTTER PIN	GOUILLE	SPLIT
21	99900030/6	1	ASS. KIT PESO ANT.	FRONT WEIGHT KIT	KIT POIDS ANTERIEUR	VORDERGEWICHTVORRICHTUNG
22	25519997/1	1	PESO	WEIGHT	POIDS	GEWICHT
23	12760520/0	3	VITE	SCREW	VIS	SCHRAUBE
24	12155000/0	3	DADO	NUT	ECROU	MUTTER
41	99900080/2	1	ASS. KIT TRAINO	HITCH KIT	KIT DE TRAINAGE	ZUGVORRICHTUNG
42	82033103/1	1	BARRA	ROD	BARRE	STANGE
43	25510021/1	1	PERNO	PIN	PIVOT	BOLZEN
44	24487999/0	1	COPPIGLIA	COTTER PIN	GOUILLE	SPLIT
45	12793301/0	2	VITE	SCREW	VIS	SCHRAUBE
46	12293201/0	4	DADO	NUT	ECROU	MUTTER
51	82180050/0	1	CARICA BATTERIE	BATTERY CHARGER	CHARGEUR DE BATTERIES	BATTERIELADEGERÄT
61	18737950/0	1	TELO DI COPERTURA	CLOTH	BÂCHE	PLANE





N.	CODE	Q.TY	DESCRIZIONE	DESCRIPTION	DESCRIPTION	BESCHREIBUNG
71	99900038/0	1	KIT MULCHING	MULCHING KIT	KIT MULCHING	MULCHINGVORRICHTUNG
72	25140093/0	1	DEFLETTORE	DEFLECTOR	DEFLECTEUR	ABWEISER
73	25394007/0	1	MANICO	HANDLE	GUIDON	STIEL
74	25510077/0	1	PERNO	PIN	PIVOT	BOLZEN
75	25430245/0	1	MOLLA	SPRING	RESSORT	FEDER
76	12735410/0	1	VITE	SCREW	VIS	SCHRAUBE
77	25280000/1	1	IMPUGNATURA	HANDGRIP	BRANCHE	GRIFF
78	25840011/1	1	TIRANTE IN GOMMA	ELASTIC TIE-ROD	TIRANT ELASTIQUE	ELASTISCHE ZUGSTÄBE
79	25253004/0	2	GANCIO	HOOK	CROCHET	HAKEN

www.emc-motoculture.com

J JP JT JR JTP JB JX

92

92 hydro

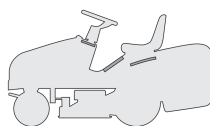

ETICHETTE
LABELS
ETIQUETTES
KLEBZETTEL

2004

014.0

1 / 1

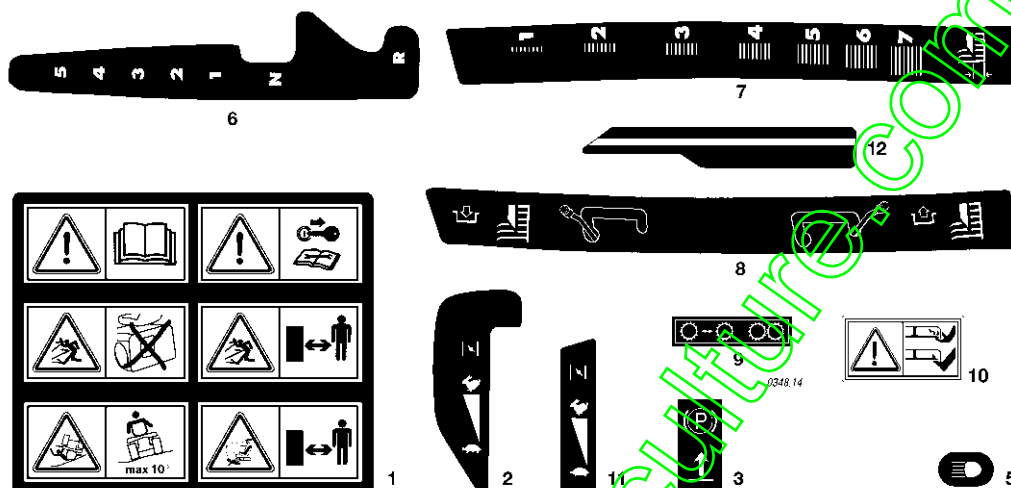

N.	CODE	Q.TY	DESCRIZIONE	DESCRIPTION	DESCRIPTION	BESCHREIBUNG
1	14357190/0	1	ETICHETTA	LABEL	ETIQUETTE	KLEBZETTEL
2	14357209/1	1	ETICHETTA (J - JP - JTP - JX)	LABEL (J - JP - JTP - JX)	ETIQUETTE (J - JP - JTP - JX)	KLEBZETTEL (J - JP - JTP - JX)
3	14356185/1	1	ETICHETTA	LABEL	ETIQUETTE	KLEBZETTEL
5	14357424/1	1	ETICHETTA	LABEL	ETIQUETTE	KLEBZETTEL
6	14357210/1	1	ETICHETTA (mecc.)	LABEL (mech.)	ETIQUETTE (mec.)	KLEBZETTEL (mech.)
7	14357211/1	1	ETICHETTA	LABEL	ETIQUETTE	KLEBZETTEL
8	14357360/1	1	ETICHETTA	LABEL	ETIQUETTE	KLEBZETTEL
9	14357423/1	1	ETICHETTA (hydro)	LABEL (hydro)	ETIQUETTE (hydro)	KLEBZETTEL (hydro)
10	14356699/0	2	ETICHETTA	LABEL	ETIQUETTE	KLEBZETTEL
11	14357357/1	1	ETICHETTA (JT - JR - JB)	LABEL (JT - JR - JB)	ETIQUETTE (JT - JR - JB)	KLEBZETTEL (JT - JR - JB)
12	14357361/1	1	ETICHETTA	LABEL	ETIQUETTE	KLEBZETTEL