

## Models 452 and 472

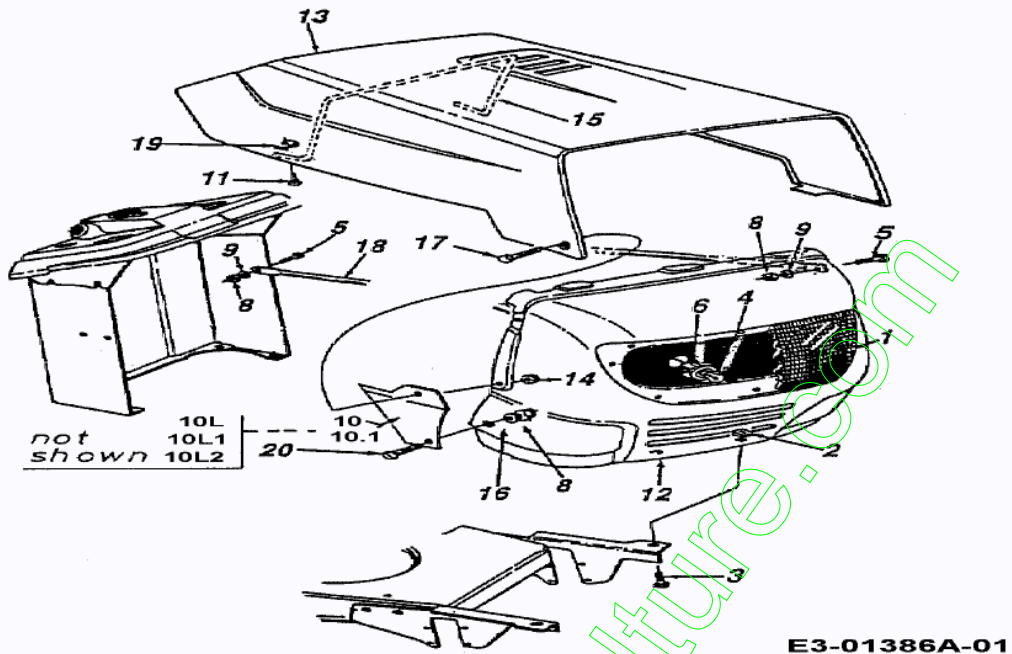

www.emc-motoculture.com

Position	Numéro de lapièce	#	Appellation I	Appellation II
1	731-1503A	1	OPTIQUE DE PHARE	FINISH:KLAR
2	726-0211	2	ECROU EN TOLE 5/16-18	726-0211
3	710-0118	2	VIS	FINISH:PHOS & OIL
4	725-0963	2	AMPOULE ELECTRIQUE	FINISH:
5	710-0258	2	VIS	710-0258
6	725-1651	2	PORTE AMPOULE	925-1651
8	712-3006	4	ECROU HEXAGONAL	FINISH:SPEC-100015
9	736-0329	2	RONDELLE GROWER	FINISH:SPEC-100016 24.8195.16
10	783-0366638	1	HABILLAGE LATÛRAL ; DROIT	2 STY / MTD RED
10.1	783-0366665	1	HABILLAGE LATÛRAL ; DROIT	2 STY / YARDMAN GREEN
10L	783-0367638	1	HABILLAGE LATÛRAL À GAUCHE	2 STY / MTD ROT
10L1	783-0367665	1	HABILLAGE LATÛRAL À GAUCHE	2 STY / YARDMAN GRÛN
10L2	783-0367668	1	HABILLAGE LATÛRAL ; GAUCHE	2 STY / MOOS GRÛN
11	710-0589	2	VIS PARKER HEX.:#10-16:0.750	FINISH:MTD SPEC-100016 TYPE 1
12	783-0156A	1	GRILLE 3 STYLE	783-0156A-0638/0662/0665
13	783-0250	1	CAPOT	783-0250-0638/0674/0640/665
14	712-3027	2	ECROU HEXAGONAL 1/4-20:GRF	FINISH:MTD SPEC-100015
15	732-0704	1	ETRIER: CAPOT	FINISH:PHOS & OIL
16	736-0270	2	RONDELLE GROWER	FINISH:MTD SPEC-100016
17	738-0952	2	AXE	.375 X .125: 1/4-20
18	749-0722B	2	ACCORE ; DROITE;/ GAUCHE	749-0722B-0637 / SCHWARZ
19	726-0130	2	ECROU 10Z TYPE U	FINISH:PHOS & OIL SIEHE ZG.
20	710-0924	2	VIS EN T#TE PLATE 1/4-20X;75"	FINISH:MTD STD 701-01000

www.emc-motoculture.com

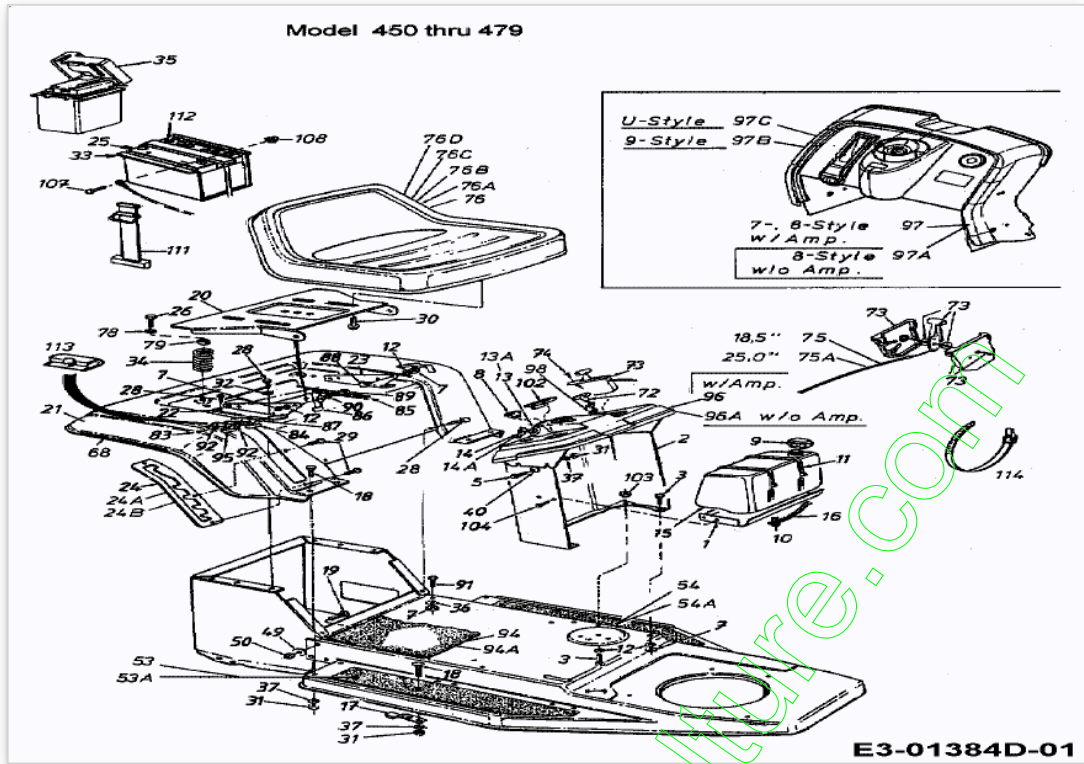

www.emc-motoculture.com

Position	Numéro de pièce	Appellation I	Appellation II	Remarque
1	17932	SUPPORT RESERVOIR	STYLE-1	
2	17933A	SUPPORT TABLEAU DE BORD	17933A-0637	
3	710-3025	VIS	FINISH:MTD SPEC-100015	
5	710-0258	VIS	710-0258	
7	712-3010	ECROU HEX. 5/16-18:GR5	FINISH:MTD SPEC-100015	
8	725-0634	COMMUTATEUR	FINISH: SCHWARZ	
9	751-0603	BOUCHON RESERVOIR ESSENCE	FINISH: SCHWARZ	
10	726-0205	COLLIER DE SERRAGE DE BOYAU	FINISH:PHOS UND GELB LACKIERT	
11	726-0209	COLLIER	FINISH: SCHWARZ	
12	736-0119	RONDELLE	FINISH:MTD SPEC-100016	
13	725-0267	CONTACTEUR A CLE 5 FICHES	B.6PIN ERS.629-0234) 925-0267	
13A	725-1396	CONTACTEUR A CLE 6 FICHES	725-1396	
14	725-0201	CLE DE CONTACT	FINISH:VERNICKELT 079.12.707	
14A	725-1341B	CLE DE CONTACT SANS LOGO	725-1341B	
15	751-0553	RESERVOIR 5 L ENV.	FINISH:NATUR SIEHE ZG.	
16	751-0535-15	TUYAU / ESSENCE	751-0535 15" LANG	
17	761-0194	FREIN DE LAME	761-0194	
18	710-0134	VIS ; T#TE PLATE	FINISH:MTD SPEC-100015	
19	710-0793	VIS	710-0793	
20	783-0039A	SUPPORT SIEGE	783-0039A-0637/0665	
21	783-0354	BAC DE SI#GE	400'96/783-0354-0638	
22	17704	ÜQUERRE FIXATION SI#GE DROITE	17704-0637	
23	17703	ÜQUERRE DE FIXATION GAUCHE	17703-0637	
24	783-0384	PLAQUE D'ÜPAISSEUR DE COUPURE	VERZINKT	
24A	17553	PLAQUE D'EP#ISSEUR DE COUPURE	VERZINKT	
24B	783-0872	PLAQUE HAUTEUR DE COUPE	7-FACH	
25	725-1705D	BATTERIE U1 12V/12AH	U1-7	
26	710-0817	VIS HEXAGONALE	FINISH:MTD SPEC-701-01002	
28	710-0726	VIS 5/16-12:0.750:HXINDWS	FINISH:MTD STD 701-01002	
29	710-1017	VIS	FINISH:MTD SPEC-100016	
30	710-0773	VIS HEXAGONALE	FINISH:MTD SPEC-100016 TYPE 1	
31	712-0287	ECROU HEXAGONAL 1/4- 20:GR2	FINISH:701-01000 / 912-0287	
32	736-0607	RONDELLE	FINISH:MTD SPEC-100016	
33	783-0349	BO#TIER DE BATTERIE	FINISH:LACKIERT SCHWARZ *	
34	732-0588	RESSORT DE PRESSION	732-0588	
35	731-0871B	BOITIER DE BATTERIE	731-0871B	
36	736-0242	RONDELLE CONIQUE.340X.872X.060	FINISH:MTD SPEC-100016	
37	736-0329	RONDELLE GROWER	FINISH:SPEC-100016 24.8195.16	

Position	Numéro de pièce	Appellation I	Appellation II	Remarque
40	736-0270	RONDELLE GROWER	FINISH:MTD SPEC-100016	
49	736-0217	RONDELLE GROWER	FINISH:MTD SPEC-100016	
50	712-0241	ECROU HEX.: 3/8-24:GR5	FINISH:MTD SPEC-100015	
53	723-0308C	MARCHE-PIED	Antirutschbelag	
53A	735-0252	TAPIS CAOUTCHOUC DROIT		
54	723-0309C	REVETEMT MARCHEPIED GAUCH	Antirutschbelag	
54A	735-0253	TAPIS CAOUTCHOUC GAUCHE	735-0253	
68	731-0511-81	GARNITURE	731-0511-81	
72	746-0616A	CABLE STARTER 58.4CM	746-0616A	
73	831-0823A	MANETTE GAZ AUTOPORTEE	931-0823A 400/700 o.Gaszug	
74	710-0779A	VIS	FINISH:701-01002 or 101616	
75	746-0776	CABLE ACCELERATEUR B&S	746-0776	
75A	746-0775	CABLE GAZ L 64 cm	746-0775 L 64 cm	
76	757-0363A	SIEGE INFERIEUR NOIR		dossier bas
76A	757-0360A	SIEGE DOSSIER MOYEN		dossier medium
76B	757-0348	VOIR 757-0348A	757-0348	dossier haut
76C	757-0364	SIEGE INFERIEUR JAUNE	757-0364	dossier bas
76D	757-0365	SIEGE JAUNE YARDMAN	757-0365	dossier medium
78	736-0159	RONDELLE .349 X 88X.06"	FINISH:MTD SPEC-100015	
79	722-0160	RONDELLE D'ATTÛNUATION	722-0160	
83	710-0227	VIS	FINISH:MTD SPEC-100016 TYPE 1	
84	725-1439	RESSORT SURETE DE SIEGE	SI.-SCHALTER SITZ:SPEC-100015	
85	732-0581B	RESSORT DE TRACTION	732-0581B	
86	17239A	LEVIER / CONTACT	17239A	
87	726-0278	PLAQUE D'ISOLATION	FINISH:NATUR ODER SCHWARZ	
88	738-0155	VIS EPAULEE	FINISH:MTD SPEC-100015	
89	738-0296	AXE EPAULE	FINISH:SPEC-100015	
90	736-0141	RONDELLE	FINISH:MTD SPEC-100016	
91	710-0604	VIS HEX.TT:5/16-18:0.62	FINISH:MTD SPEC-701-01006	
92	726-0279	PLAQUE D'ISOLATION	FINISH:NATUR ODER SCHWARZ	
94	723-0423	MARCHE-PIED	Antirutschbelag	
94A	735-0254	TAPIS CAOUTCHOUC CENTRAL		
95	725-1303	RESSORT DE SURETE SIËGE	SI.-SCHALTER SITZ:SPEC-100015	
96	731-1228	TABLEAU DE BORD	731-1228 ( mit Amp.M.+Lichts	avec ampermetre et contacteur lumière
96A	731-1502	TABLEAU DE BORD	731-1502 (ohne Amp.M.+Lichts	sans ampermetre et contacteur lumière
97	731-0063	TABLEAU DE CONTRÛLE		7-Style, 8-Style
97A	731-04184	TABLEAU DE BORD	OHNE AMPEREMETER	8-Style à partir du numéro de fabrication AI162L50011
97B	731-2432	TABLEAU DE BORD	400er RIDER/NACHARB.A.731-0063	9-Style
97C	731-0063*-U	TABLEAU DE BORD	UNIVERT-FRANCE/OHNE LICHTSCH.-	
98	17782	CLIP: STARTER DE TRACTION	FINISH:VERZINKT	

Position	Numéro de lapièce	Appellation I	Appellation II	Remarque
102	725-0925	AMPEREMETRE ANGULEUX	725-0925	
103	712-3007	ECROU HEX. 5/16-18 GR5	FINISH:MTD SPEC-100015	
104	710-1355	VIS HEX.TT:M5X.7:10.00:HEXFLG	HEXFLG WN 1321:SPEC-701-01006	
107	710-3015	VIS:1/4-20:.75:GR5:STD	FINISH:MTD SPEC-100015	
108	712-0271	ECROU 1/4-20"+ DISQUE DENTE	FINISH:MTD SPEC-100016 GR5	
111	723-0444	CEINTURE DE SECURITE BATTERIE	FINISH:SCHWARZ	
112	725-0689	BOUCHON BATTERIE	725-0689	
113	783-0297	ÜCRAN SIËGE- COMMUTATEUR	783-0297-0637	
114	725-0157	COLLIER DE SERRAGE3/16X0.5X7.4	MATERIAL:NYLON-SCHWARZ	fsg

www.emc-motoculture.com

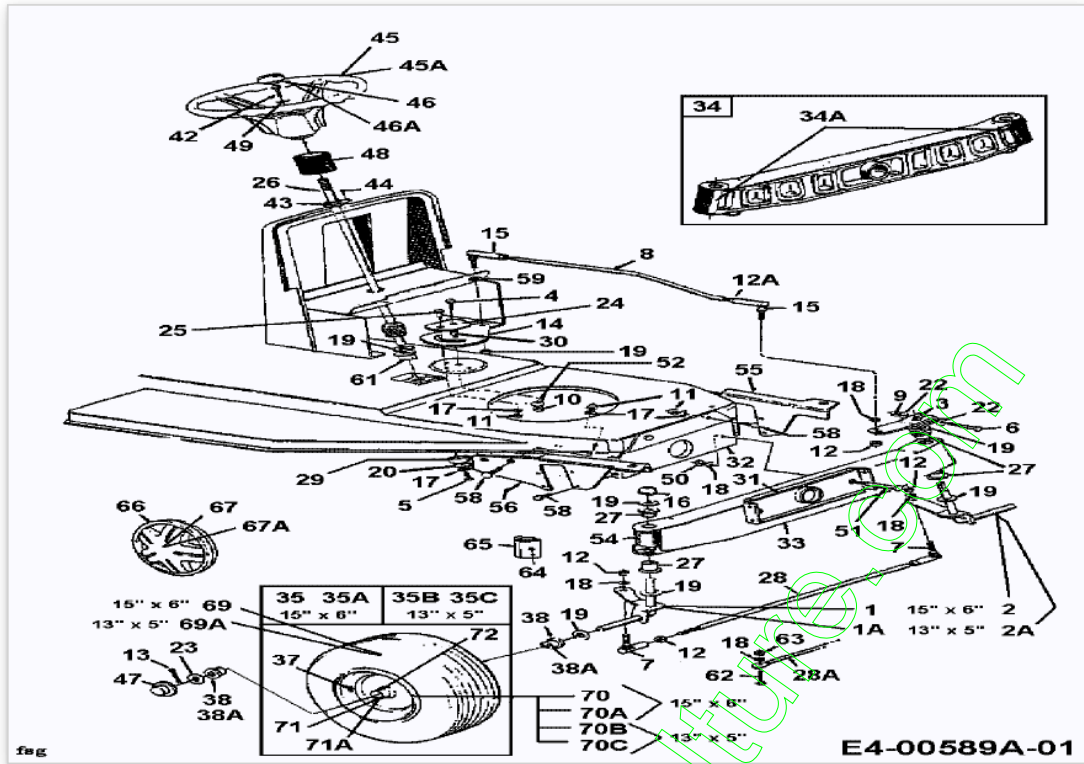

www.emc-motocult.fr

Position	Numéro de lapièce	Appellation I	Appellation II	Remarque
1	17584A637	AXE AVANT DROIT	SCHWARZ GEPULVERT	15" x 6"
1A	683-0040A637	AXE DROIT 3.41 X 4.05		13" x 5"
2	17585A637	AXE AVANT GAUCHE NOIR	SCHWARZ GEPULVERT	15" x 6"
2A	683-0041A637	AXE AVANT GAUCHE	SCHWARZ GEPULVERT	13" x 5"
3	683-0055	LEVIER DIRECTION	683-0055/983-0055-0637	
4	710-0152	VIS HCCS:3/8-24:1.00:GR5:STD	910-0152	
5	710-0538	VIS HEX.:5/16-18:.625:GR.5:LOC	FINISH:701-01000	
6	710-0772	VIS HEX.:5/16-24X2.00	710-0772	
7	723-3018	ROTULE DE DIRECTION 3/8-24	FINISH:	
8	711-1117A	TIGE DE DIRECTION		
9	712-3057	ECROU HEXAGONAL	FINISH:MTD SPEC-100015	
10	712-0214	ECROU	FINISH:SPEC-100015	
11	712-3010	ECROU HEX. 5/16-18:GR5	FINISH:MTD SPEC-100015	
12	712-0262	ECROU	FINISH:MTD SPEC-100015	
12A	712-0240	ECROU HEX.: 7/16-20:GR2	FINISH:MTD SPEC-100015	
13	714-0470	EPINGLE EX AF-43010	FINISH:SPEC-100015 470 32 32	
14	717-0622A	SEGMENT DE DIRECTION	717-0622A	
15	723-0448	ROTULE DE DIRECTION 7/16-20		
16	726-0214	BOUCHON	FINISH:SCHWARZ	
17	736-0119	RONDELLE	FINISH:MTD SPEC-100016	
18	736-0169	BAGUE ÜLASTIQUE	FINISH:MTD SPEC-100016	
19	736-0187	RONDELLE .64X1.24X.06	FINISH:MTD SPEC-100016	
20	736-0343	RONDELLE .330 ID X 1.25 X .12	FINISH:MTD 701-100015	
22	736-0271	RONDELLE	HD:FINISH MTD SPEC-100016	
23	736-0285	RONDELLE .635 X 1.589 X .06	FINISH:MTD SPEC-100015	
24	17198A	PLAQUE	17198A	
25	738-0141	AXE		
26	738-0937	ARBRE DE DIRECTION	738-0937	
27	741-0659	BAGUE DE TRAVERSE AVANT	941-0659	
28	747-0753	KIT TRINGLE DIRECTION	E-TEIL-SET	ajustable
28A	747-0861	VOIR 747-0861-0637	747-0861-0637	non ajustable
29	750-0532	ENTRETOISE 980IDX1.250DX.0420		
30	750-0535	ENTRETOISE	FINISH:GEÖLT	
31	17548	SUPPORT	17548 SCHWARZ GEPULVERT	
32	17547	SUPPORT	17547	
33	683-0128	VOIR 683-0128-0637	683-0128-0637	
34	719-0342A	TRAIN AVANT FONTE		
34A	737-3000	GRAISSEUR	GLEITMITTEL	
35	634-0087	ROUE COMPL 15 X 6,0	634-0087-0911/0662	
35A	634-0091	ROUE COMPL	15 X 6	
35B	634-0097	ROUE COMPL 13" x 15"	634-0097-0662	
35C	634-0099	ROUE COMPL 13X5-6 COUSSINET	MIT CARLISLE REIFEN FELGE GRAU	
37	734-0255	VALVE:PNEU	TR 412-P / 32.6mm / 934-0255	
38	741-0487A	PALIER DE BRIDE	741-0487A (BR.748-0184)	Roulement de



Position	Numéro de pièce	Appellation I	Appellation II	Remarque
				plastique
38A	741-0569	ROULEMENT DE ROUE AVANT	741-0569	Roulement à billes
42	710-0643	VIS HEX.: 5/16-18:1.00:GR5	FINISH:MTD SPEC-100015	
43	741-0501	PALIER DE BRIDE ARBRE DE DIREC	FINISH:KUNSTSTOFF SCHWARZ	
44	710-0837	VIS	FINISH:MTD SPEC-100016 TYPE 1	
45	731-1693	VOLANT 12" 3 RAYONS		seulement pour couvercle rond
45A	731-1687	VOLANT 3 RAYONS		seulement pour couvercle carré
46	731-0220	COUVERCLE / VOLANT	731-0220	
46A	731-1459	COUVERCLE BOUCHON /VOLANT	731-1459	quarrée
47	731-0484A	ENJOLIVEUR DEVANT	KUNSTSTOFF SCHWARZ 931-0484A	
48	731-0954	SOUFFLET GOMMEUX	731-0954	
49	736-0242	RONDELLE CONIQUE.340X.872X.060	FINISH:MTD SPEC-100016	
50	712-0431	ECROU STOP 3/8-16:GRF	FINISH:MTD SPEC-100015	
51	738-0527	BOULON	738-0527	
52	736-0356	RONDELLE	FINISH:MTD STD 701-01001	
54	731-1649	PALIER	PVC SCHWARZ: 450/500	
55	783-0255	SUSPENSION D'AXE GAUCHE	783-0255	
56	783-0256	SUSPENSION D'AXE DROITE	783-0256-0637	
58	710-0604	VIS HEX.TT:5/16-18:0.62	FINISH:MTD SPEC-701-01006	
59	736-0217	RONDELLE GROWER	FINISH:MTD SPEC-100016	
61	741-0225	BAGUE HEXAGONALE TEFLON 6 PANS	FINISH:KUNSTSTOFF SCHWARZ	
62	710-0459	VIS	710-0459 / 910-0459	
63	712-0711	ECROU HEXAGONAL	MTD SPEC-100015 912-0711	
66	727-0425A	CLIP ENJOLIVEUR		
67	734-1613A	ENJOLIVEUR 6" gris		
67A	734-1787A	ENJOLIVEUR 6" JAUNE VIF	734-1787A	
68	712-0240	ECROU HEX.: 7/16-20:GR2	FINISH:MTD SPEC-100015	
69	734-0864	PNEU 15*600*6	Block TURF PRO	
69A	734-0298	PNEU 13*500*6	734-0298-0901/0902 000.75.551	
70	634-0088	JANTE 6.0x4.5	634-0088-0662	
70A	634-0090	JANTE	634-0090-0662	
70B	634-0096	JANTE	634-0096	
70C	634-0098A	ZUSAMMENBAU:FELGE:KUGELLAGER:	6X3.87 GEBOHRT	
71	737-0211A	DOUILLE/GRAISSE	737-0211A	seulement pour 15" x 6" avec roulement de plastique
71A	737-0280	GRAISSEUR	737-0280 / 937-0280	seulement pour 15" x 6" et 13" x 5" avec roulement à bille

Position	Numéro de lapièce	Appellation I	Appellation II	Remarque
72	737-0212	GRAISSEUR	737-0212	n`est pas utiliser dans 15" x 6" avec roulement à bille

[www.emc-motoculture.com](http://www.emc-motoculture.com)

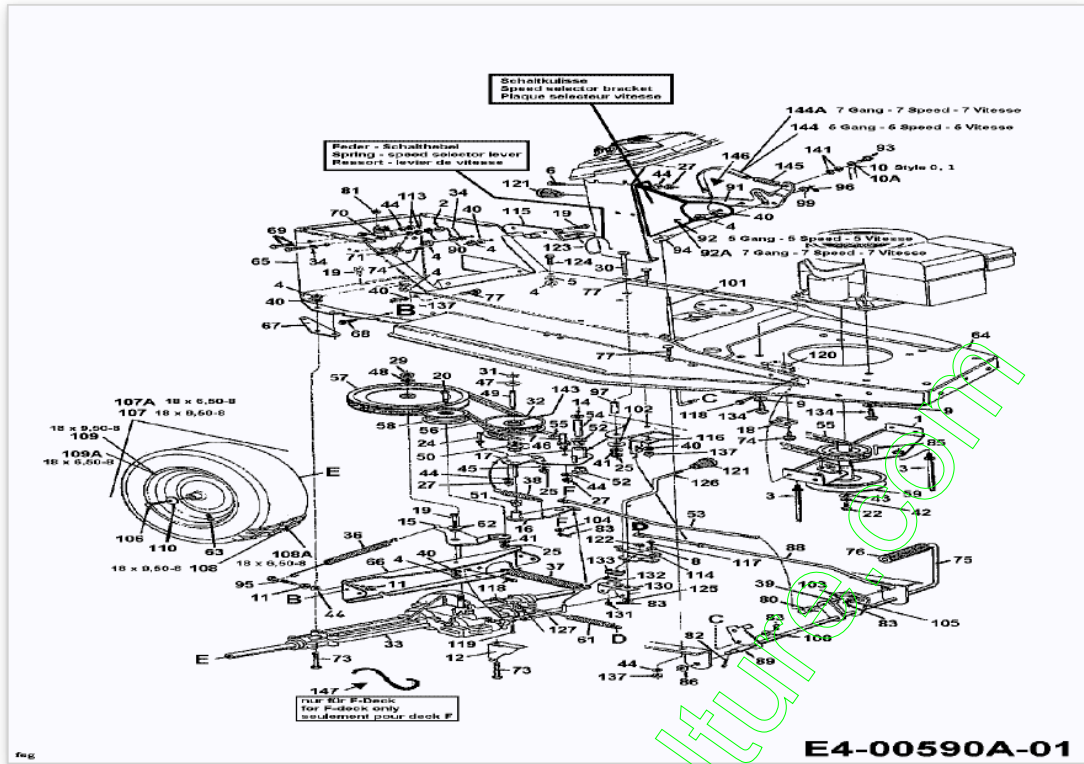

Position	Numéro de lapièce	#	Appellation I	Appellation II	Remarque
1	783-0265A		PROTECTION COURROIE	783-0265A-0637	
2	712-0291		ECROU EX AF-43013	FINISH:ASTM F1941 FE/ZN 3AN	
3	711-1044		BOULON	5/16-18X4.6 /911-1044	
4	712-0267		ÛCROU HEXAGONAL	FINISH:MTD STD 701-01000	
5	736-0242		RONDELLE CONIQUE.340X.872X.060	FINISH:MTD SPEC-100016	
6	710-0286		VIS	FINISH:701-01000	
7	711-1000		GUIDE COURROIE 25 X 3.0	FINISH: 911-1000	
8	736-0270		RONDELLE GROWER	FINISH:MTD SPEC-100016	
9	736-3072		RONDELLE .38 x.93 x.110:HT	FINISH:701-01001	
10	749-0836A		TRINGLE	749-0836A-0637	seulement pour style 0 et 1
10A	749-0820		TRINGLE	749-0820	
11	712-0138		ECROU HEX. 1/4-28"	FINISH:MTD SPEC-100015	
12	17128A637		WINKEL	SCHWARZ GEPULVERT	
13	710-0176		VIS HEX.:5/16- 18:2.75:GR5:STD	(21.1441.82)FINISH:SPEC-100015	
14	736-0235		RONDELLE 3/8X1.26 X .172	FINISH:MTD STD 701-01000	
15	17694		SUPPORT	FINISH:SIEHE ZG.	
16	16554A		SUPPORT VARIATEUR	16554A-0637 / 16554A-Z	
17	16676B		SUPPORT COMPLET	FINISH:PHOS&OIL OPT. LACKIERT	
18	17962		PLAQUE DE SUPP. P. COMMUTATEUR	FINISH:WIE GESTANZT	
19	710-0118		VIS	FINISH:PHOS & OIL	
20	710-0151		VIS HEXAGONALE	FINISH:MTD SPEC-100015	
22	710-0757		VIS	FINISH:701-01000 910-0757	
24	711-0768		GUIDE DE COURROIE	711-0768	
25	712-0241		ECROU HEX.: 3/8-24:GR5	FINISH:MTD SPEC-100015	
27	712-0287		ECROU HEXAGONAL 1/4- 20:GR2	FINISH:701-01000 / 912-0287	
29	712-3035		ECROU HEXAGONAL	FINISH:STD 701-01000 912-3035	
30	710-0902		VIS HHCS:3/8-24:3.75GR5:STD	FINISH:MTD STD 701-01000	
31	716-0114		CIRCLIPS	FINISH:PHOSPHATIERT DIN 471	
32	717-0800A		POULIE VARIATEUR DE VITESSE	917-0800A NADELLAGER 741-0404	
33	618-0166A		TRANSMISSION 1 VITESSE	618-0166A	
34	736-0607		RONDELLE	FINISH:MTD SPEC-100016	
36	732-0384		RESSORT DE TRACTION	FINISH:SIEHE ZG.	
37	732-0459		RESSORT	FINISH:MTD STD 701-01000	
38	732-0568		RESSORT DE TRACTION	.50 OD X 2.54 LG	
39	736-0117		RONDELLE 3/8X.620X.033	FINISH:MTD SPEC-100015	
40	736-0119		RONDELLE	FINISH:MTD SPEC-100016	
41	736-0169		BAGUE ÛLASTIQUE	FINISH:MTD SPEC-100016	
42	736-0171		RONDELLE GROWER	FINISH:MTD SPEC-100016	
43	736-0322		RONDELLE .450 X 1.250 X .164	FINISH:SPEC-100016 936-0322	
44	736-0329		RONDELLE GROWER	FINISH:SPEC-100016 24.8195.16	
45	736-0331		RONDELLE CONIQUE	FINISH:MTD SPEC-100016	

Position	Numéro de lapièce	#	Appellation I	Appellation II	Remarque
46	736-0355		RONDELLE	FINISH:701-01001	
47	736-0414		RONDELLE TÛFLON	FINISH:WEISS: 936-0414	
48	736-0427		RONDELLE	FINISH:MTD STD 701-01001	
49	738-0569		AXE DE VARIATEUR	738-0569	
50	741-0405		ENTRETOISE	.56 ID x 1.25 OD x.06/941-0405	
51	741-0419		SUPPORT DE BRIDE / DOUILLE	741-0419	
52	741-0495		BAGUE	FINISH:KUNSTSTOFF WEISS	
53	747-0599A		TRINGLE	747-0599A	
54	750-0703		ENTRETOISE 375IDX.625ODx1.54	750-0703	
55	754-0280		COURROIE MOTEUR/VARIATEUR	754-0280 / 954-0280	
56	754-0281		COURROIE VARIATEUR/BOITE	754-0281/954-0281	
57	656-0003		POULIE	656-0003 DURCHM.20,4CM	
58	756-0643		POULIE TENDEUR PLASTIQUE	756-0643	
59	756-0551		POULIE DOUBLE MOTEUR	756-0551 / E-TEIL-SET	
61	732-0413		RESSORT DE TRACTION	FINISH:PHOS & OIL	
62	748-0234		RONDELLE EPAULEE	FINISH:ROSTPREVENTION	
63	734-0255		VALVE:PNEU	TR 412-P / 32.6mm / 934-0255	
64	17588B		CHASSIS AVANT	'97/17588B	
65	783-0180A		CHASSIS ARRIERE	400'96	
66	16654A		SUPPORT DE TRANSMISSION	16654A-0637	
67	16659		RENFORT	16659-0637	
68	710-0726		VIS 5/16-12:0.750:HXINDWS	FINISH:MTD STD 701-01002	
69	710-0258		VIS	710-0258	
70	725-1426		RELAIS DE DEMARRAGE SOLENOID	725-1426 Mutter 712-0271	
71	725-0459		CONTACT VOIR 753-0685	725-0459	
73	710-0176		VIS HEX. 5/16- 18:2.75:GR5:STD	(21.1441.82)FINISH:SPEC-100015	
74	710-0351		VIS	FINISH:MTD SPEC-100016	
75	17644A		PEDALE D EMBRAYAGE ET FREINS	SCHWEIßTEIL:LACKIERT	
76	735-0239		CAOUTCHOUC/PEDALE 4;0 LG	FINISH:SCHWARZ	
77	710-1012		VIS COTELEE: 5/16-24 x.87"LG	RD HD FINISH:PHOS & OIL	
80	711-0198		FUSEAU D'ÛCROU	FINISH:MTD SPEC 701-01000	
81	712-0271		ECROU 1/4-20"+ DISQUE DENTE	FINISH:MTD SPEC-100016 GR5	
82	714-0470		EPINGLE EX AF-43010	FINISH:SPEC-100015 470 32 32	
83	714-0507		GOUPILLE FENDUE 3/32 X .750	FINISH:MTD SPEC-100015	
85	714-0114		CLAVETTE	FINISH:PLAIN	
86	736-0256		RONDELLE .635ID X 930 OD X.03	736-0256	
88	747-0593		TIGE DE FREIN	747-0593	
89	750-0800		ENTRETOISE	.640IDX.76ODX1.21	

Position	Numéro de lapièce	#	Appellation I	Appellation II	Remarque
90	725-0976A		CABLE DE MASSE	725-0976A	
91	17457B		LEVIER DE VITESSE	FINISH:VERZINKT SIEHE ZG.	
92	16693B		PLAQUE SELECTEUR 5 VITESSE	E-TEIL-SET	
92A	16694B		PLAQUE / AJUSTEMENT 7 VITESSE		
93	738-0138		AXE	738-0138	
94	711-0677		FUSEAU D'ÛCROU - EX 711- 0611	FINISH:MTD SPEC-100015	
95	710-0428		VIS HEXAGONALE	FINISH:701-01000	
96	714-0104		GOUPILLE	FINISH:PHOS AND OIL	
97	750-0703		ENTRETOISE 375IDX.625ODx1.54	750-0703	
99	736-0264		RONDELLE: .330 x.630 x.0635	FINISH:SPEC-100015 936-0264	
100	736-0463		RONDELLE	FINISH:MTD SPEC-100015	
101	747-0675A		TIGE FILETEE	747-0675A	
102	736-0133		RONDELLE .411X1.25X1.00	FINISH:MTD SPEC-100015	
103	714-0115		GOUPILLE FENDUE 1/8 x 1.0	FINISH:MTD SPEC-100015	
104	736-0275		RONDELLE	FINISH:MTD SPEC-100015	
105	736-0278		RONDELLE	FINISH:MTD SPEC-100016	
106	710-0627		VIS HEX. 5/16-24:.750 GR5:LOCK	FINISH:MTD SPEC-100015	
107	734-0817	2	ROUE COMPL 18X9,50-8 ST ELEC	FINISH:SIEHE FARBVARIANTEN	
107A	734-0592662	2	ROUE COMPLETE 18 6.5 GRISE	FELGE:OYSTER GRAY 788-0662	
108	734-0448	2	PNEU 18*950*8	TURF SAVER 734-0448-0901	
108A	734-0294	2	PNEU 18*650 *8	SQ:SH:TS 734-0294-0901/902	
109	634-0070	2	JANTE	FINISH:788-0499/674/0662	18" x 9,50"
109A	634-0069662	2	JANTE	OYSTER GRAU GEPULVERT	18" x 6,50"
110	736-0242		RONDELLE CONIQUE,340X,872X.060	FINISH:MTD SPEC-100016	
113	712-0298		ECROU HEXAGONAL AF- 43015	FINISH:MTD SPEC-100015	
114	17178A		PLAQUE D'AJUSTEMENT	17178A	
115	17839		SUPPORT	17839	
116	17597		SUPPORT DE TIGE DE FREIN	17597-Z	
117	710-0289		VIS	710-0289/910-0289	
118	710-0599		VIS A SIX PANS CREUX	FINISH:MTD SPEC-101617	
119	714-0149B		GOUPILLE FENDUE 1/2"	FINISH:MTD SPEC-701-01006	
120	725-1657A		SECURITE D'EMBRAYAGE	Sich.Mähwerk+Kuppl. GRAU	
121	720-0232		BOUTON DE LEVIER MANUEL	FINISH:KUNSTSTOFF SCHWARZ	
122	726-0231		CLIPS	726-0231	
123	732-0525		RESSORT DE RAPPEL LEVIER	FINISH:PRE-GALVANIZED	
124	710-0650		VIS HEX.:TT:5/16-18:0.875	FINISH:MTD SPEC-100016 TYPE 1	
125	736-0226		RONDELLE	FINISH:MTD SPEC-100015	
126	747-0694A		LEVIER EX 747-0694	FINISH:747-0694A-Z	
127	747-0685		LEVIER DE RACCORD	747-0685	
130	17179		SUPPORT	17179	

Position	Numéro de lapièce	#	Appellation I	Appellation II	Remarque
131	710-0227		VIS	FINISH:MTD SPEC-100016 TYPE 1	
132	726-0222		PLAQUE ISOLATEUR	726-0222	
133	725-0758		INTERRUPTEUR KIT 753-0580	725-0758	
134	710-0502A		VIS HEX. 3/8-16:1.250 LG.	SELBSTSCHN. SPEC / 701-01002	
137	712-0123		ÛCROU HEXAGONAL	FINISH:701-01000	
141	736-0141		RONDELLE	FINISH:MTD SPEC-100016	
143	741-0404	2	ROULEMENT A AIGUILLE VARIATEUR	741-0404/941-0404	
144	777-9586A		BANDE INDICATRICE 7 VITESSES	777-9586A	
144A	777-0404A		BANDE INDICATRICE 5 VITESSES	777-0404A	
145	732-0691		RESSORT	732-0691	
146	747-0816		CROCHET IND VIS	747-0816	
147	732-0722		CROCHET DE RESSORT	732-0722	
148	24.6486.22		RONDELLE	A10,5 VERZINKT 736-0702 ST	

www.emc-motoculture.com

**618-0166A**

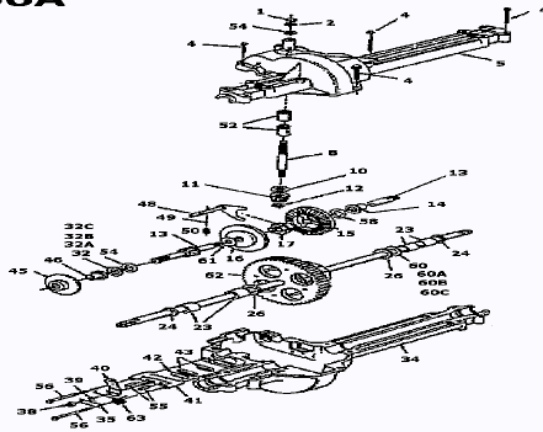

Ⓢ  
NICHT ABGEBILDET - FETT  
NOT SHOWN - GREASE  
SANS ILLUSTRATION - GREASE

[www.emc-motoculture.com](http://www.emc-motoculture.com)



Position	Numéro de lapièce	#	Appellation I	Appellation II	Remarque
1	732-0614	1	CIRCLIPS	FINISH:ZINC PHOSPHATE	
2	716-0231	1	CIRCLIPS	FINISH:SPEC-100016	
4	710-1325	1	VIS HEXAGONALE	FINISH:SPEC-100016 TYPE 1	
5	719-0358	1	DEMI CARTER SUPERIEUR	719-0358	
8	711-0861	1	AXE	711-0861	
10	736-0335	1	RONDELLE 1 5/8XA1.25"X.06	FINISH:SIEHE ZG.	
11	717-0633	1	PIGNON 14 DENTS	717-0633/917-0633	
12	716-0108	1	CIRCLIPS 7/16"	FINISH:PHOSPATIERT 916-0108	
13	711-1016	1	ARBRE D'ENTRAINEMENT FR.A G.	711-1016/911-1016	
14	741-0336	1	BAGUE	FINISH:SIEHE ZG. 941-0336	
15	717-1362	1	PIGNON CONIQUE 42 DENTS PT US	717-1362 / 917-1362 *	
16	717-1363	1	PIGNON CONIQUE 42 DENTS GR US	717-1363/917-1363 *	
17	718-0228	1	CRABOT	718-0228	
23	741-0340	1	DOUILLE	ÖLIMRÄGNIERT EXXON 941-0340	
24	721-0338	1	JOINT	.75 x 1.00 x .125:FINISH STD	
26	736-0445	1	RONDELLE	FINISH:MTD SPEC-100016	
32	736-0495	1	RONDELLE	FINISH:SIEHE ZG. 936-0495	
32A	736-0336	1	RONDELLE 5/8X1.00X.030	FINISH:MTD SPEC-100016	
32B	736-0494	1	RONDELLE	FINISH:MTD SPEC-100016	
32C	736-0337	1	RONDELLE 5/8 IDX1.0 ODX.040	MTD STD 701-01001 936-0337	
34	719-0313B	1	MOITIÛ INFÛRIEURE DE CARTER	UNTEN	
35	718-0150	1	LANG. DE SUPP.: ANTI ROTATION	FINISH:SPEC-100015	
38	712-0273	1	ECROU HEXAGONAL 5/16-24"	FINISH:MTD SPEC-100015	
39	736-0371	1	RONDELLE 1.344XA .875"	FINISH:MTD SPEC-100016	
40	717-0772A	1	LEVIER DE FREIN	717-0772A	
41	761-0198	1	CARTER DE FREIN	FINISH:NONE	
42	717-0682	1	INSERT DE FREIN	FINISH:NONE 917-0682	
43	717-0678	1	PLAQUETTE DE FREIN	FINISH:	
45	761-0202	1	DISQUE DE FREIN	FINISH:ÖL UND FETTFREI	
46	741-0337	1	BAGUE	941-0337	
48	611-0011	1	FOURCHETTE	FINISH: 911-0011	
49	741-0862	1	BILLE	FINISH: SIEHE ZG.	
50	732-0863	1	RESSORT ; PRESSION 225X.50"	FINISH: PHOS & OIL 932-0863	
52	741-0335	1	ROULEMENT 1,5/8X1/2" LG	FINISH:SIEHE ZG. 941-0335	
54	736-0349	1	RONDELLE 5/8 IDX10 OD X .020	FINISH:SIEHE ZG.	
55	741-0343	1	GOUJON DE PRESSION 5/16"	FINISH:SIEHE ZG. 941-0343	
56	710-1206	1	VIS HEX. TT:1/4-20:2.375	FINISH:MTD SPEC-100016 TYPE 1	
57	717-1364	1	PIGNON DIFFÛRENTIEL 58 DENTS	717-1364	
58	736-0349	1	RONDELLE 5/8 IDX10 OD X .020	FINISH:SIEHE ZG.	
60	736-0492	1	RONDELLE 76X1.5X.010	FINISH:MTD SPEC-100016	
60A	736-0493	1	RONDELLE 76X1.5X.020	FINISH:MTD SPEC-100016	
60B	736-0351	1	RONDELLE .75x1.50"	FINISH:MTD SPEC-100016	
60C	736-0445	1	RONDELLE	FINISH:MTD SPEC-100016	

Position	Numéro de lapièce	#	Appellation I	Appellation II	Remarque
61	736-0519	1	RONDELLE	FINISH:WET TUMBLE 936-0519	
62	618-0233	1	DIFFÜRENTIEL COMPLET	618-0233/918-0233	
63	732-0743	1	RESSORT	FINISH:ZINC PHOS&OIL 932-0743	
64	737-0148	1	GRAISSE		fsg

[www.emc-motoculture.com](http://www.emc-motoculture.com)



Position	Numéro de lapièce	#	Appellation I	Appellation II	Remarque
1	738-0143	1	VIS EPAULEE	FINISH:MTD SPEC 100015 (EU)	
2	17580	1	SUPPORT	17580-0637	
3	736-0169	1	BAGUE ÜLASTIQUE	FINISH:MTD SPEC-100016	
4	712-0798	1	ECROU HEXAGONAL	912-0798	
5	710-0428	1	VIS HEXAGONALE	FINISH:701-01000	
6	710-0351	1	VIS	FINISH:MTD SPEC-100016	
7	732-0640	1	RESSORT LEVIER RELEVAGE	FINISH:PHOS & OIL	
8	631-0026	1	POIGNÜE	631-0026 RB 731-2509 in USA	
9	17591A	1	LEVIER	FINISH:17591A-Z VERKLIPPT	
10	710-0604	1	VIS HEX.TT:5/16-18:0.62	FINISH:MTD SPEC-701-01006	
11	736-0119	1	RONDELLE	FINISH:MTD SPEC-100016	
12	712-0267	1	ÜCROU HEXAGONAL	FINISH:MTD STD 701-01000	
13	750-0379	1	ENTRETOISE .647 IDX 780DX .85	750-0379	
14	714-0507	1	GOUPILLE FENDUE 3/32 X .750	FINISH:MTD SPEC-100015	
15	736-0185	1	RONDELLE 3/8.738X.063	FINISH:MTD SPEC-100015	
16	714-0104	1	GOUPILLE	FINISH:PHOS AND OIL	
17	17597	1	SUPPORT DE TIGE DE FREIN	17597-Z	
18	747-0746	1	TIGE FILETEE	FINISH:PHOS & OIL ODER ZINC	
19	16682P	1	DOUILLE DE GUIDAGE	16682P-0637	
20	712-0130	1	ECROU POLY STOP 3/8-16" GR 8	FINISH:MTD SPEC-100015	
21	736-0314	1	RONDELLE	FINISH:MTD SPEC-100016	
22	736-0116	1	RONDELLE	FINISH:MTD SPEC-100015	
23	714-0470	1	EPINGLE EX AF-43010	FINISH:SPEC-100015 470 32 32	
24	712-0123	1	ÜCROU HEXAGONAL	FINISH:701-01000	
25	726-0272	1	COLLIER	FINISH:MTD SPEC-100015	
26	712-0237	1	ECROU EX.712-0305	FINISH:MTD SPEC-100015	
27	17555	1	VOIR 97555	17555-0637	
28	738-0281	1	VIS ; ÜPAULE:.625 x.17:3/8- 16	FINISH:SPEC-100015 938-0281	
29	17574	1	ARBRE	17574-0637 SCHWEIßTEIL	
30	738-0667	1	AXE	E-TEIL-SET	
31	747-0745	1	LEVIER	17.8 LG FINISH:SIEHE ZG	
32	17573A637	1	PLAQUE STABILISATEUR	SCHWARZ GEPULVERT	trapézoidal
32A	783-0281637	1	PLAQUE STABILISATEUR PLATEAU	SCHWARZ GEPULVERT	rectangulaire
33	17554	1	SUPPORT	17554-0637	
34	17563	1	FERRURE D	17563-0637	
35	736-0336	1	RONDELLE 5/8X1.00X.030	FINISH:MTD SPEC-100016	
36	17582	1	SUPPORT	17582-0637	
37	710-1012	1	VIS COTELEE: 5/16-24 x.87"LG	RD HD FINISH:PHOS & OIL	
38	17568	1	SUPPORT &&&	17568	
39	17557	1	SUPPORT GAUCHE	17557-0637	

Position	Numéro de lapièce	#	Appellation I	Appellation II	Remarque
40	17556	1	SUPPORT		
41	17581	1	SUPPORT	17581-0637	
42	17562	1	FERRURE G	17562-0637	
43	747-0584	1	ETRIER 38x 1,25 x LG	747-0584	
44	97709	1	MOLLETTE DE REGLAGE EX 17709	97709/17709	
45	97598	1	ÜCLISSE DE SUSPENSION	97598	seulement pour plateau de coupe A et C
45A	683-0111	1	ECLISSE DE JONCTION COMPL	.88 X3.31 LG	pour plateau de coupe D,E,F
47	736-0192	1	RONDELLE .531 X 93 X .090	FINISH:MTD SPEC-100015	
48	736-0185	1	RONDELLE 3/8.738X.063	FINISH:MTD SPEC-100015	
49	736-0101	1	RONDELLE	FINISH:MTD SPEC-100015	
50	732-0638	1	RESSORT	FINISH:PHOS & OIL 32cm	
51	732-0603	1	RESSORT	FINISH:PHOS & OIL	
52	710-3038	1	VIS HHCS:5/16- 18:.875:GR5:STD	FINISH:701-01000	
54	17962	1	PLAQUE DE SUPP. P. COMMUTATEUR	FINISH:WIE GESTANZT	
55	725-0157	1	COLLIER DE SERRAGE3/16X0.5X7.4	MATERIAL:NYLON-SCHWARZ	

www.emc-motoculture.com

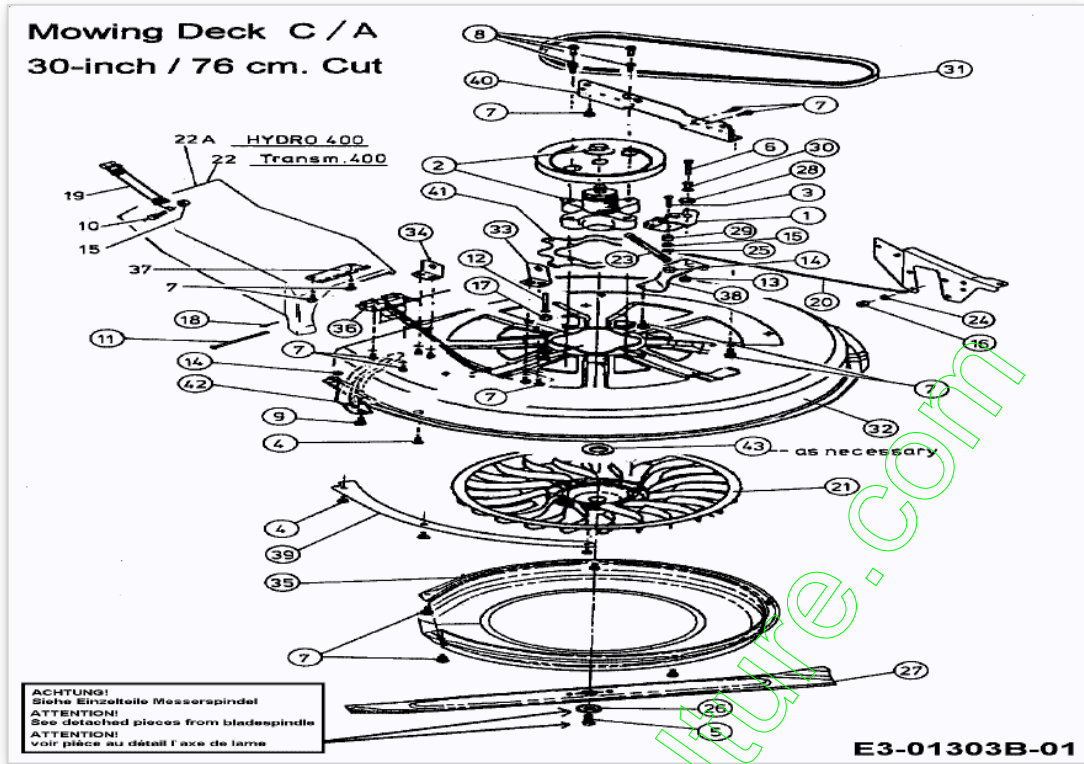

Position	Numéro de lapièce	#	Appellation I	Appellation II	Remarque
1	17116	1	FREIN A LAMES	17116/97116	
2	618-0139A	1	PALIER COMPLET 76CM ETOILEE	618-0139A	
3	710-0106	1	VIS HEX. 1/4- 20:1.25:GR5:SPEC	FINISH:MTD SPEC-100015	
4	710-1687	5	VIS A TETE PLATE	FINISH:Zn5gIcB 22.3419.12	
5	710-1382	1	VIS HEX. M10X1X60LG. DIN 960	10.9 "SCHWARZ"	
6	710-3180	1	VIS HEX. 5/16- 18:1.75:GR5:STD	FINISH:SPEC-100015	
7	710-0599	16	VIS A SIX PANS CREUX	FINISH:MTD SPEC-101617	
8	710-0602	4	VIS	FINISH:MTD SPEC-100016 TYPE 1	
9	710-1759	2	VIS	MTD SPEC-100015 (000.02.242)	
10	710-3015	1	VIS:1/4-20.:75:GR5:STD	FINISH:MTD SPEC-100015	
11	711-1054	1	BOULON ,250 X 4,42	GR2:FINISH:MTD SPEC-100015	
12	711-1065	1	AXE	FINISH:PHOS & OIL SIEHE ZG.	
13	712-0265	1	ECROU	FINISH:701-01001	
14	712-0691	1	ECROU HEXAGONAL	MTD SPEC-100015 24.1426.14	
15	712-3006	1	ECROU HEXAGONAL	FINISH:SPEC-100015	
16	712-3010	1	ECROU HEX. 5/16-18:GR5	FINISH:MTD SPEC-100015	
17	712-3046	1	ECROU	FINISH:MTD SPEC-100015	
18	714-0507	1	GOUPILLE FENDUE 3/32 X .750	FINISH:MTD SPEC-100015	
19	723-0383	1	SANGLE POUR GOULOTTE D'EJECTI	FINISH:	
20	727-0470	1	CABLE DE FREIN DE LAME	16.47 LG	
21	731-1583	1	TURBINE DE VENTILATION	21 1000 000 820 FARBE: SCHWARZ	
22	731-1605C	1	CANAL D'ÜJECTION		seulement pour Transmatik
22A	731-2235	1	CANAL D'ÜJECTION		seulement pour Hydrostat
23	732-0604	1	RESSORT	FINISH:PHOS & OIL	
24	736-0204	1	RONDELLE .344 X 62 X.03	FINISH:MTD SPEC-100015	
25	736-0342	1	RONDELLE PLATE .283 x.75 x.030	FINISH:MTD STD 701-01000	
26	736-0684	1	RONDELLE	VERGÜTET-BLANK-GEÖLT	
27	742-0609C	1	LAME COUPE 76CM AVEC TURBINE		
28	748-0234	1	RONDELLE EPAULEE	FINISH:ROSTPREVENTION	
29	750-0555	1	ENTRETOISE 254 IDX 50 OD x 3	750-0555	
30	750-0755	1	ENTRETOISE 330IDX.625ODX.915	750-0755	
31	754-0445	1	COURROIE DE LAME COUPE 76CM	754-0445 / 954-0445	
32	783-0247B	1	CARTER TONDEUSE	783-0247B-0637-0665	
33	783-0248	1	SUPPORT PLATEAU	FINISH:LACKIERT	
34	783-0249	1	SUPPORT PLATEAU	FINISH:LACKIERT	
35	783-0289	1	COUVERTURE SOUFFLANTE	F564.000.00 FINISH:LACKIERT	

Position	Numéro de lapièce	#	Appellation I	Appellation II	Remarque
36	783-0291	1	SUPPORT CONDUIT EJECTION	FINISH:BLAU CHROMATIERT	
37	783-0292	1	SUPPORT CONDUIT EJECTION	FINISH:GELBVERZINKT	
38	783-0295	1	SUPPORT	783-0295-0637	
39	783-0301	1	PLATEAU REINFORCE	783-0301-0637 783-0301*	
40	783-0304B	1	SUPPORT PLATEAU TONDEUSE	FINISH:SCHWARZ GEPULVERT	
41	783-0571	1	RENFORT	SCHWARZ GEPULVERT 783-0571*	
42	683-0215	1	ENTRETOISE COMPL. PIECE SOUDE	A u.C DECK / 400er RIDER/0637	
43	736-0693	X	RONDELLE	28X40X0.3 24.6271.51 ST	
44	813-04198	1	PLATEAU COMPL 30"	TRANSMATIC	

www.emc-motoculture.com



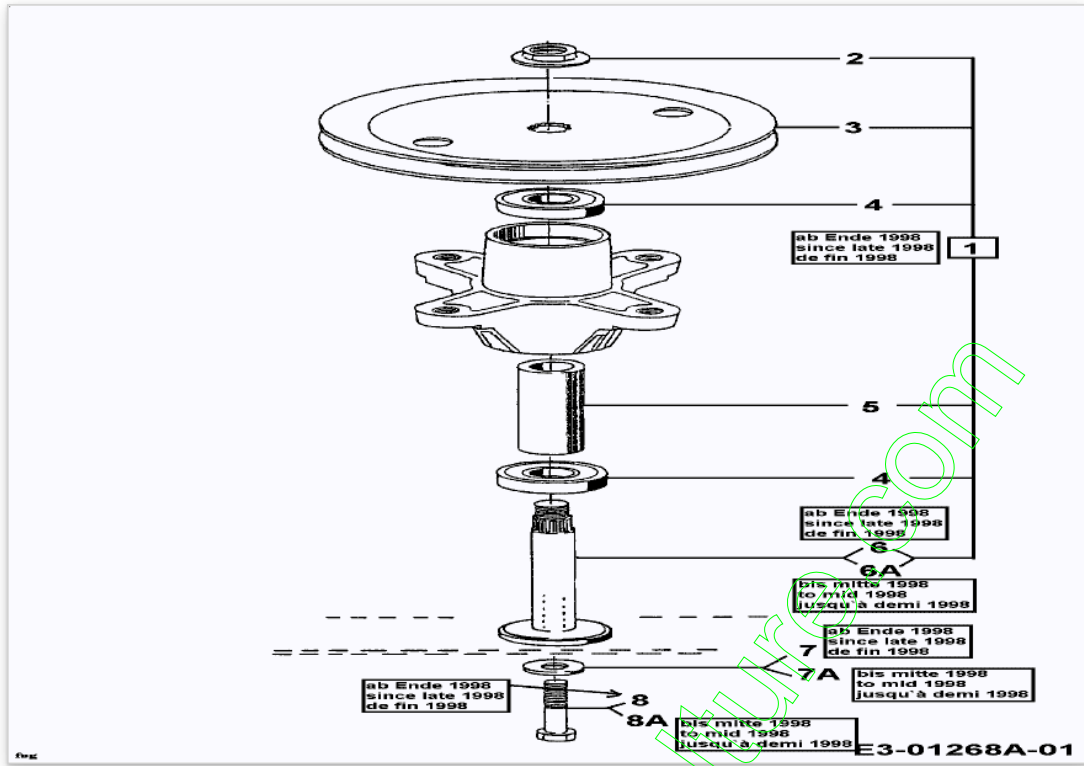

www.emc-motoculteur.com

Position	Numéro de lapièce	#	Appellation I	Appellation II	Remarque
1	618-0139A	1	PALIER COMPLET 76CM ETOILEE	618-0139A	
2	712-0417A	1	ÜCROU HEX. AV. FLANC: 5/8-18	FINISH:MTD STD 701-01000	
3	756-0623	1	POULIE DE COURROIE TRAPÜZOID.	FINISH:MTD SPEC-100015	
4	741-0919	2	ROULEMENT j BILLES	FINISH:SIEHE SPEC.	
5	750-0990	1	ENTRETOISE D'ECARTEMENT	FINISH:EINGEÖLT	
6	738-0911A	1	AXE POUR PALIER 618-0139A	(NACHARBEIT AUS 738-0911)	de fin 1998
6A	753-0751	1	KIT ARBRE DE LAME 76 CM		jusqu`au demi 1998
7	736-0684	1	RONDELLE	VERGÜTET-BLANK-GEÖLT	de fin 1998
7A	736-0510	1	RONDELLE	736-0510	jusqu`au demi 1998
8	710-1382	1	VIS HEX. M10X1X60LG. DIN 960	10.9 "SCHWARZ"	de fin 1998
8A	710-0314	1	VIS HEX.HCCS7/16-20:1.00:GR5	STD FINISH:701-01000	jusqu`au demi 1998

www.emc-motoculture.com

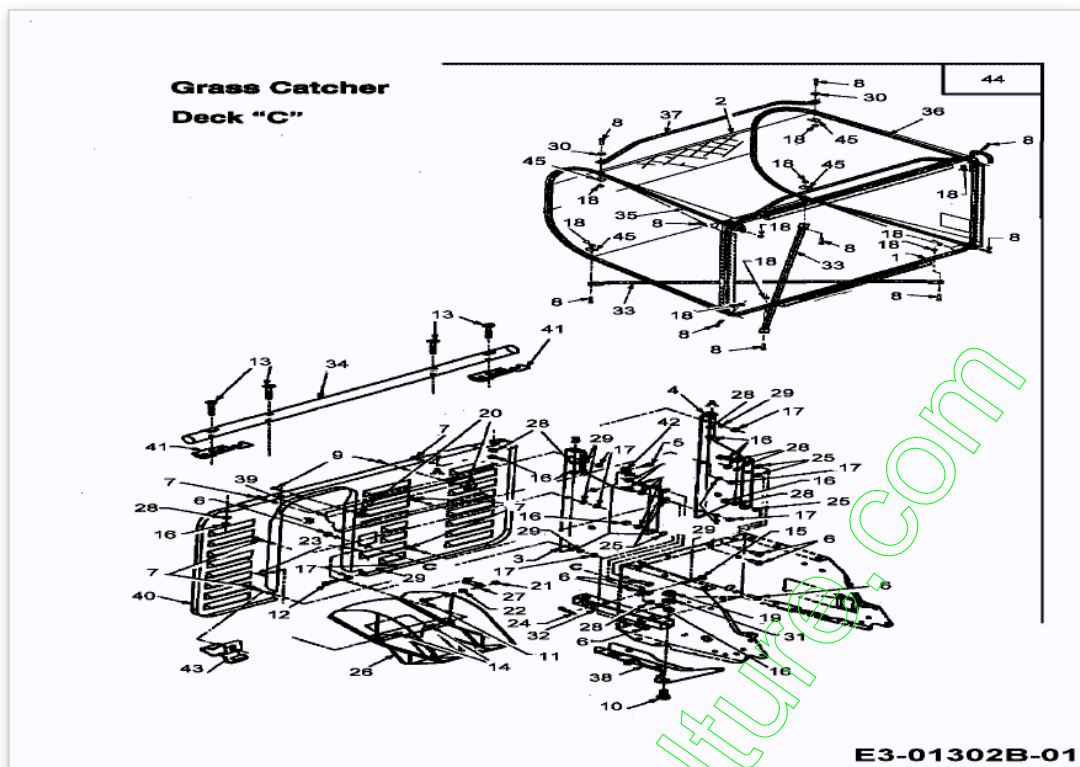

Position	Numéro de pièce	#	Appellation I	Appellation II
1	649-0011	1	CADRE BAC DE RAMASSAGE AVANT	649-0011-0637
2	664-0073B	1	TOILE DE BAC 200 LITRES "C"	NUR GEWEBESAC: SCHWARZ
3	683-0106		CONSOLE PR PLAQUE ARR DROIT	
4	683-0105		CONSOLE PR PLAQUE ARR GAUCHE	SCHWARZ GEPULVERT
5	710-0599		VIS A SIX PANS CREUX	FINISH: MTD SPEC-101617
6	710-3008		VIS 5/16-18:.75:GR5:STD	SPEC-701-01006 or.SPEC-100015
7	710-0751		VIS HEX.: 1/4-20:.620:GR5:STD	FINISH:SPEC-100015
8	710-1194		VIS	FINISH:701-01000
9	710-0351		VIS	FINISH:MTD SPEC-100016
10	21.1442.10		Vis	M12X25 8.8 710-1701
11	710-0134		VIS ; Tête PLATE	FINISH:MTD SPEC-100015
12	710-0597		VIS 1/4-20:1.00/GR5/SPEC	FINISH:701-100015
13	710-1174		VIS	FINISH:701-01000
14	711-0701		GOUJON	FINISH:MTD SPEC-100015
15	711-0679		BOLT .375 X 1.88"	FINISH:PHOS & OIL
16	712-3010		ECROU HEX. 5/16-18:GR5	FINISH:MTD SPEC-100015
17	712-3006		ECROU HEXAGONAL	FINISH:SPEC-100015
18	712-0161		ECROU #10-24 NYLSTOP GR	FINISH:MTD SPEC-100015
19	712-0630		ECROU	MTD SPEC-100015 24.1421.25
20	712-0147		ECROU 10-24 U-TYPE	FINISH:PLAIN
21	712-0291		ECROU EX AF-43013	FINISH:ASTM F1941 FE/ZN 3AN
22	712-0271		ECROU 1/4-20"+ DISQUE DENTE	FINISH:MTD SPEC-100016 GR5
23	714-0507		GOUPILLE FENDUE 3/32 X .750	FINISH:MTD SPEC-100015
24	714-0147		GOUPILLE ; RESSORT: .125 X 1.75	FINISH:MTD SPEC-701-01006
25	726-0201		RONDELLE .3125 ID	MECHANISCH VERZINKT:SIEHE ZG.
26	731-1606A		CANAL D'ÛJECTION	
27	732-0755		RESSORT .595 x 2.105 LG	FINISH: PHOS & OIL
28	736-0119		RONDELLE	FINISH:MTD SPEC-100016
29	736-0329		RONDELLE GROWER	FINISH:SPEC-100016 24.8195.16
30	736-0400		RONDELLE PLATE .194x.62x.063	FINISH:MTD SPEC-100015
31	736-0253		RONDELLE	FINISH:MTD SPEC-100016
32	749-0966		TUBE DISPOSITIF D'ATTELAGE 400	749-0966-0637
33	749-0964		TUBE	FINISH:749-0964-0637
34	749-0963		SUPPORT BAC	749-0963
35	749-0960		CHASSIS DROIT 12x1;5x1530	749-0960-0637
36	749-0959		CHASSIS GAUCHE	749-0959-0637
37	749-0962		ETRIER BAC	749-0962-0637
38	783-0286		SUPPORT ATTACHE REMORQUE	783-0286-0637
39	783-0308		DÛFLECTEUR	
40	783-0278		PLAQUE ARRIERE	FINISH:LACKIERT
41	15995A		SUPPORT	15995A-0637
42	16606		ÛTRIER D'ACCROCHAGE	FINISH:BLAU CHROMATIERT *
43	732-0838		RESSORT BAC / HERBES	
44	813-04196		BAC ; HERBES	913-04196/753-0671
45	736-0764-Z		RONDELLE	GFS "SOFTBAG"

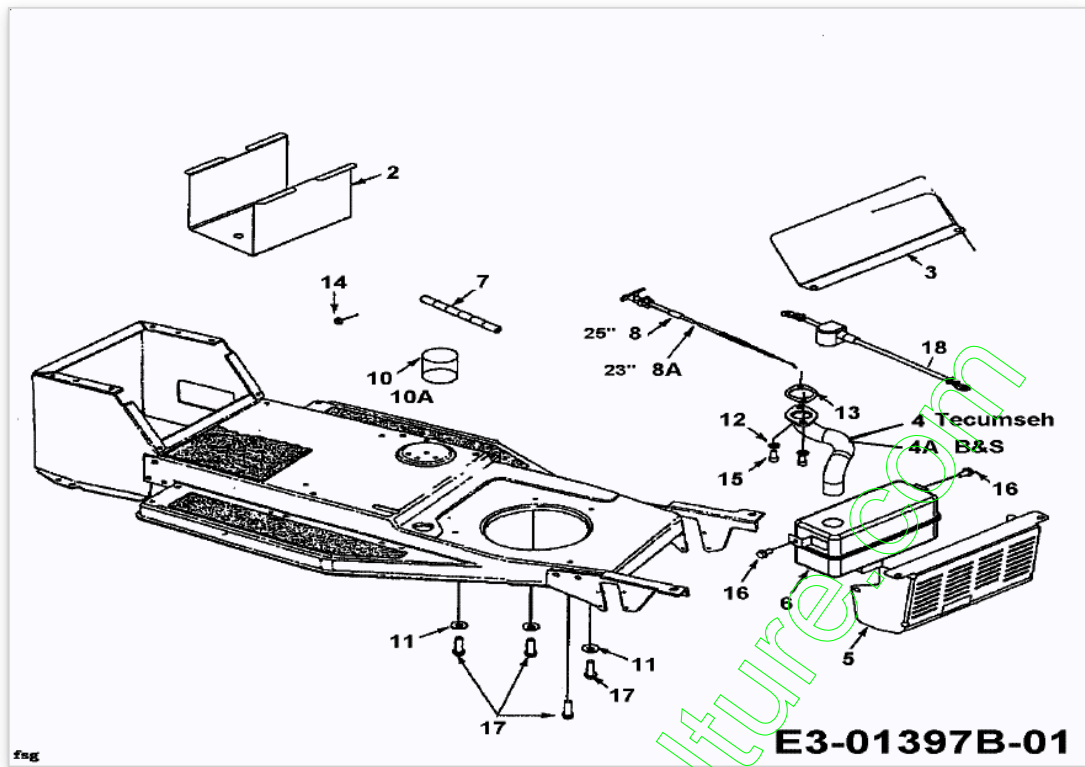

Position	Numéro de lapièce	#	Appellation I	Appellation II	Remarque
2	783-0349	1	BOÏTIER DE BATTERIE	FINISH:LACKIERT SCHWARZ *	
3	751-0642	1	PROTECTION CHALEUR	751-0642	
4	751-0640	1	COLLECTEUR	751-0640	pour moteurs Tecumseh
4A	751-0628	1	TUYAU D'ÛCHAPPEMENT B&S OHV400	751-0628	Moteurs à essence Briggs&Stratton
5	751-0631A637	1	PROTECTION DE CHALEUR	SCHWARZ GEPULVERT	
6	751-0627	1	ÛCHAPPEMENT OHV 400	751-0627	
7	751-0535-MET	1	TUYAU D'ESSENCE (PAR METRE)	Beschaf.751-0535(Acht.inchx50)	
8	746-3026	1	CABLE 25,0 LG	746-3026	
8A	746-0616A	1	CABLE STARTER 58.4CM	746-0616A	
10	000.40.520	1	HUILE	(OEM-737-0295=1.4L-0208=0.6L)	
10A	OEM737-0295B	1	HUILE MOTEUR SAE30 1.4 Litres	HD 30 (WESTEUROPA)	
11	736-3072	3	RONDELLE .38 x.93 x.110:HT	FINISH:701-01001	
12	736-0119	2	RONDELLE	FINISH:MTD SPEC-100016	
13	721-0208	1	JOINT ECHAP B/S MONO CYLINDRE	FINISH:B&S #272293	
14	712-0271	1	ECROU 1/4-20"+ DISQUE DENTE	FINISH:MTD SPEC-100016 GR5	
15	710-1314	2	VIS 5/16-18;625	710-1314	
16	710-0604A	2	VIS 5/16-18:0.625	FINISH:MTD SPEC-100016 TYPE 1	
17	710-0502A	4	VIS HEX. 3/8-16:1.250 LG.	SELBSTSCHN. SPEC / 701-01002	
18	629-0705	1	CABLE BATTERIE ROUGE 356MM	GUMMISCHUTZKAPPE GROSS ROT	

www.emc-motoculture.com

**Rider Models 400**

Engine B&S 28T707-1154-E1

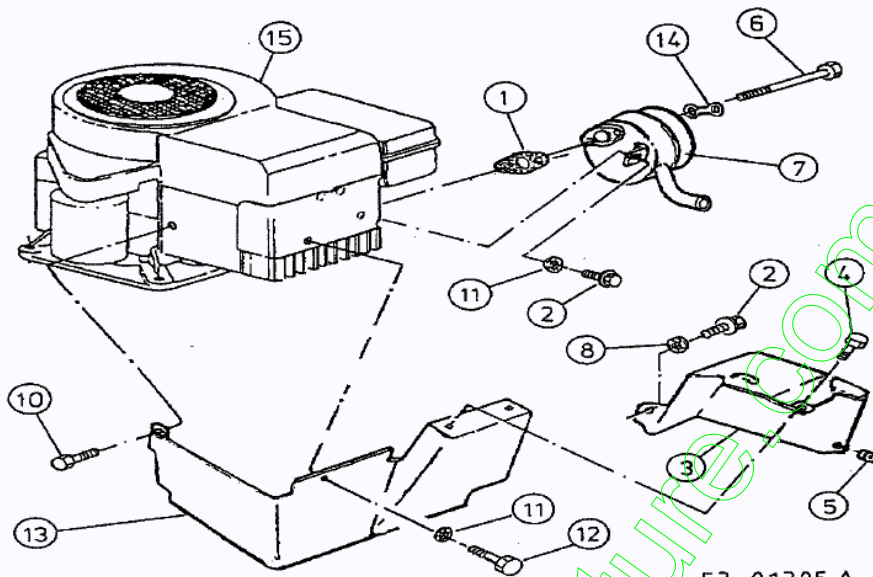

www.emc-motoculture.com

Position	Numéro de lapièce	#	Appellation I	Appellation II	Remarque
1	721-0208	1	JOINT ECHAP B/S MONO CYLINDRE	FINISH:B&S #272293	
2	710-0599	2	VIS A SIX PANS CREUX	FINISH:MTD SPEC-101617	
3	683-0042A	1	AUTOCOLLANT PROTECTION	683-0042A-0637	
4	710-1268	1	VIS HEX.:B#10-16:0.375	HXINDWSH:SP FINISH:701-01002	
5	712-0147	1	ECROU 10-24 U-TYPE	FINISH:PLAIN	
6	738-0636	2	AXE	7/16ODx3.56x5/16	
7	751-0465A	1	ECHAPPEMENT	5":B&S	
8	736-0175	2	RONDELLE GROWER:.265x.562x.025	FINISH:701-01001	
10	710-0323	1	VIS	FINISH:701-01000	
11	736-0175	1	RONDELLE GROWER:.265x.562x.025	FINISH:701-01001	
12	710-0599	1	VIS A SIX PANS CREUX	FINISH:MTD SPEC-101617	
13	16936	1	PROTECTION CHALEUR AVANT	16936	
14	032.15.001	1	SICHERUNGSBLECH IM LIEFERUM	FANG AUSPUFF 751-0465A ENTHALT	seulement avec Ref. 7
15	752B1154E1	1	MOTEUR B&S 13,0CH I/C DL12	28T707-1154-E1	

www.emc-motoculture.com





Position	Numéro de pièce	Appellation I	Appellation II	Remarque
1	629-0702	CABLE DE MASSE	8 X 13.0 LG SCHWARZ	
2	725-1707	BATTERIE		
2A	725-1635	BATTERIE 12V /20AH	C50N18L-A-CX	seulement pour machine avec plateau de coupe éjection arrière
3	629-0705	CABLE BATTERIE ROUGE 356MM	GUMMISCHUTZKAPPE GROSS ROT	
4	725-1426	RELAIS DE DEMARRAGE SOLENOID	725-1426 Mutter 712-0271	
6	725-1644	INTERRUPTEUR DE SÛCURITÛ	FINISH:MTD SPEC-100015	
7	725-1657A	SECURITE D'EMBRAYAGE	Sich.Mähwerk+Kuppl. GRAU	
8	725-0267	CONTACTEUR A CLE 5 FICHES	B.6PIN ERS.629-0234) 925-0267	
9	725-0634	COMMUTATEUR	FINISH: SCHWARZ	
11	629-0195A	FAISEAU COMPL	629-0195A	
12	725-1651	PORTE AMPOULE	925-1651	
13	725-0963	AMPOULE ELECTRIQUE	FINISH:	
14	629-0742	CABLE	#18 X 21.0 LG GRUEN	
15	629-0103	TUBE POUR INTERRUPTEUR PHARE	629-0103	
17	725-1303	RESSORT DE SURETE SIËGE	SI.-SCHALTER SITZ:SPEC-100015	
18	725-1439	RESSORT SURETE DE SIEGE	SI.-SCHALTER SITZ:SPEC-100015	
19	725-0925	AMPEREMETRE ANGULEUX	725-0925	

www.emc-motoculture.com

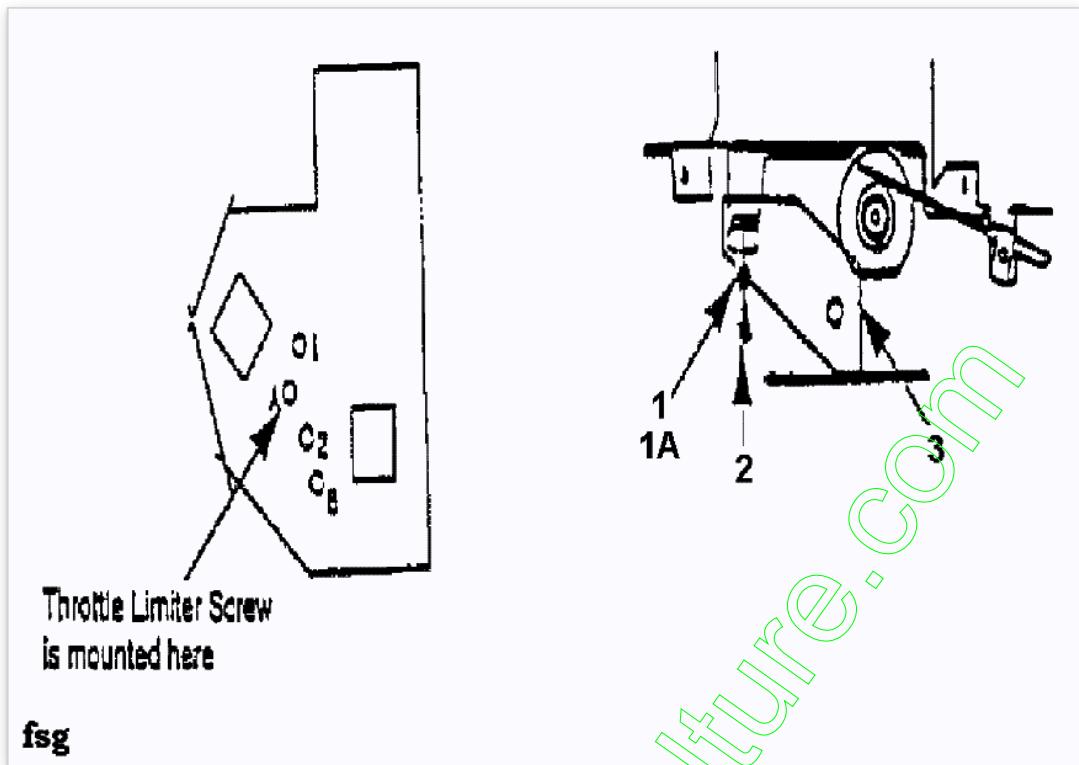

Position	Numéro de pièce	Appellation I	Appellation II
1	736-0400	RONDELLE PLATE .194x.62x.063	FINISH:MTD SPEC-100015
1A	710-0456	VIS	FINISH:701-01002
2	710-0899A	VIS HEXAGONALE	FINISH:MTD SPEC-100016
3	17483	SUPPORT	17483

[www.emc-motoculture.com](http://www.emc-motoculture.com)