

Position	Numéro de pièce	#	Appellation I	Appellation II
1	611-04049	1	FUSEE DROITE	SCHWEIßTEIL FINISH:LACKIERT
2	611-04050	1	FUSEE GAUCHE	SCHWEIßTEIL FINISH:LACKIERT
3	712-04065	2	ÜCROU HEXAGONAL	FINISH:SPEC-101616 912- 04065
4	714-0162	2	GOUPILLE FENDUE 5/32:1.25	FINISH:MTD SPEC-100015
5	719-04177	1	FINISH:SCHWARZ LACKIERT	FINISH:SCHWARZ LACKIERT
6	726-0341	2	CAPUCHON CLIPS	FINISH:SCHWARZ
7	736-0316	4	RONDELLE 1.78XA1.59"	FINISH:MTD STD 701-01000
9	738-1011A	2	AXE	FINISH:MTD STD 701-01000
10	737-3000	2	GRAISSEUR	GLEITMITTEL

www.emc-motoculture.com

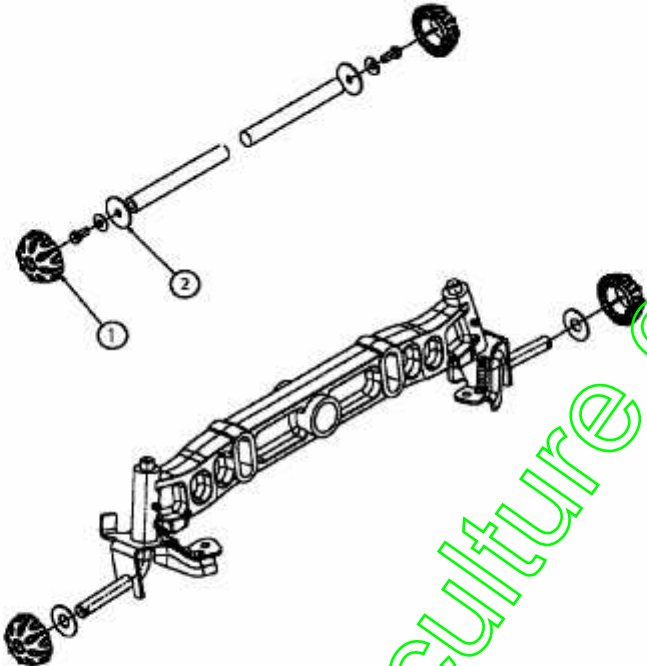

E3-02001A-01

www.emc-motoculture.com

Position	Numéro de lapièce	#	Appellation I	Appellation II
1	731-2290A	4	CAPUCHON DE ROUE	FINISH:KUNSTSTOFF SCHWARZ
2	736-0430	2	RONDELLE .350X.1.59X.062	FINISH:MTD STD 701-01000

www.emc-motoculture.com

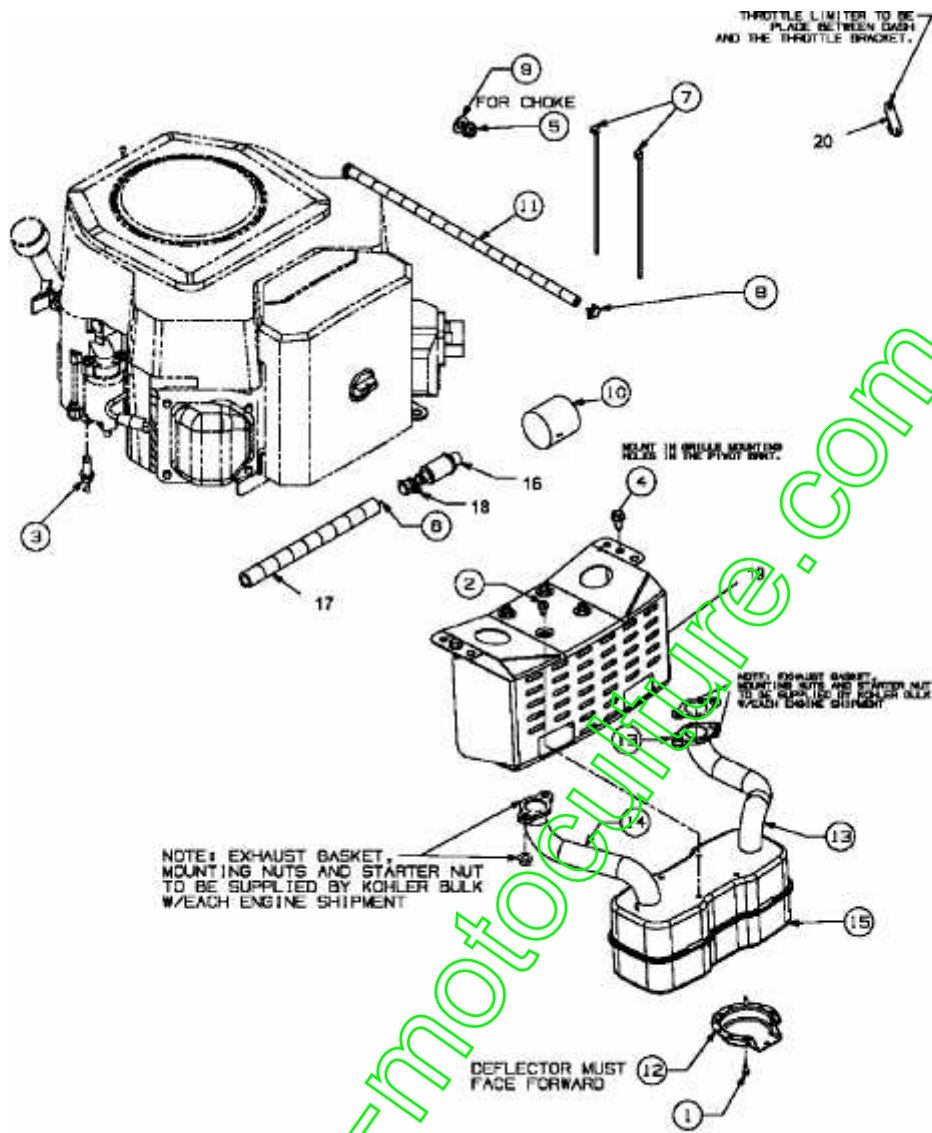

E3-03407A-01

Position	Numéro de pièce	#	Appellation I	Appellation II
1	710-0227	4	VIS	FINISH:MTD STD 701-01002
2	710-0599	4	VIS _i SIX PANS CREUX	MTD SPEC-701-01002 or 101617
3	710-0654A	4	VIS _i SIX PANS CREUX	FINISH:MTD SPEC-701-01002
4	710-0726	2	VIS 5/16-12:0.750:HXINDWS	FINISH:MTD STD 701-01002
5	712-3005	1	ÜCROU AVEC FLANC:3/8-16:GR5	FINISH:701-01000 912-3005
6	721-0331	1	PRODUIT D'ETANC. LOCTITE 582	DOSE À 50 mL
7	725-0157	2	COLLIER DE SERRAGE3/16X0.5X7.4	MATERIAL:NYLON-SCHWARZ
8	726-0205	2	COLLIER DE SERRAGE DE BOYAU	FINISH:PHOSPHATIERT (GELB)
9	736-0300	1	RONDELLE	FINISH:MTD SPEC-100015
10	737-0269	2	HD Super Turbo	HD Super Turbo
11	751-0535	1	TUYAU ESSENCE NOIR	Ø12,7+/-5.84 / Ø6,35+/-0,41
12	751-0564B	1	DEFLECTEUR:ÜCHAPPEMENT	MATERIAL:ALUMINIERTER STAHL
13	751-0644B	1	TUBE D'ECHAP.:KOHLER TWIN GAUC	FINISH:PLAIN/BARE
14	751-0645A	1	COUDE D'ÜCHAPPEMENT DROIT	FINISH:NONE
15	751-0805A	1	POT D'ÜCHAPPEMENT	TWIN
16	751-3140	1	EMBOUT DE VIDANGE	FINISH:SIEHE ZG. 951-3140
17	751-3141	1	TUYAU VIDANGE	13 X 3:FINISH KLAR METERWARE
18	751-3142	1	BOUCHON VIDANGE	FINISH:GELB 951-3142
19	783-0615D	1	DEFLECTEUR POT D'ECHAPPEMENT	FINISH:LACKIERT
20	783-04997	1	ARRET DE CABLE	KOHLER/B&S VERZINKT!

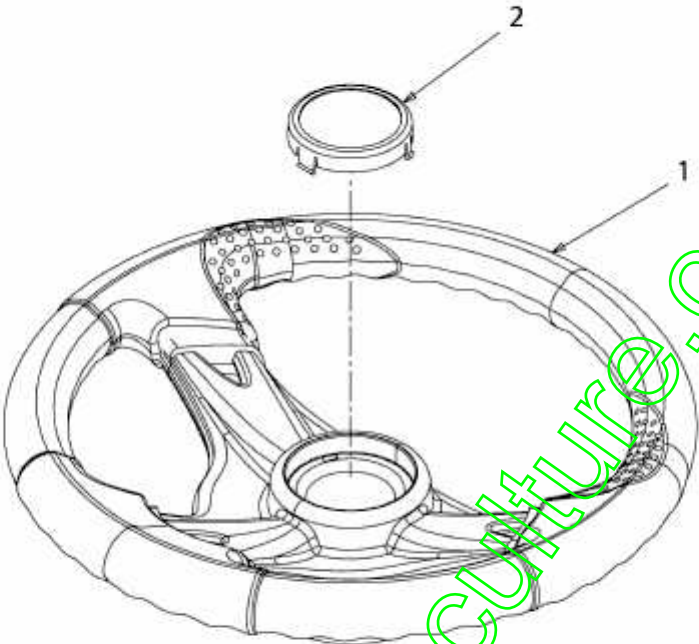

E3-02341A-01

www.emc-motoculture.com

Position	Numéro de lapièce	#	Appellation I	Appellation II
1	631-04008	1	VOLANT	SOFTGRIP
2	731-04039	1	CAPUCHON DE VOLANT SANS LOGO	FINISH:KUNSTSTOFF SCHWARZ

www.emc-motoculture.com

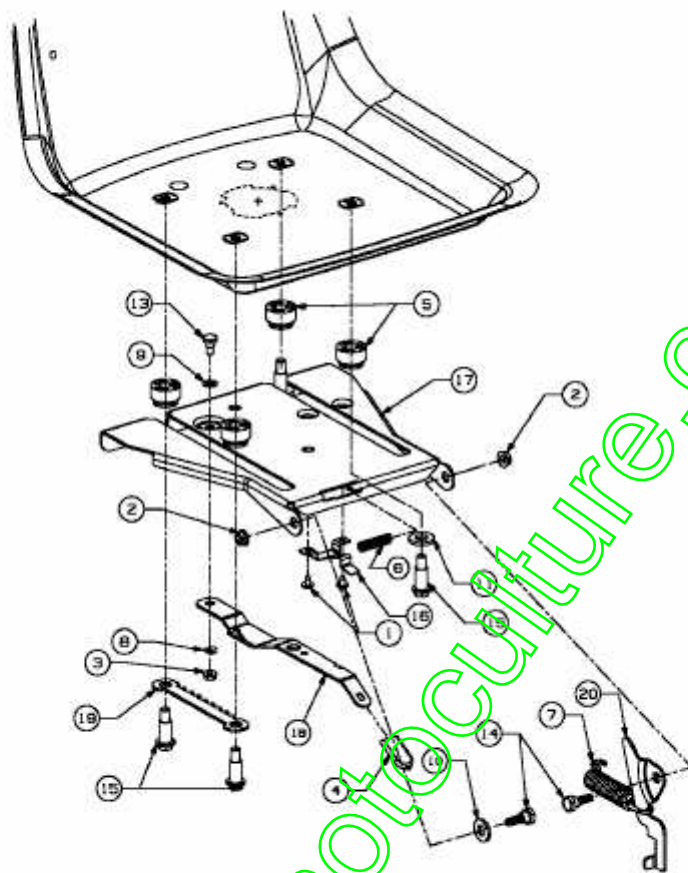

E3-02342A-01

Position	Numéro de pièce	#	Appellation I	Appellation II
1	710-1268	2	VIS HEX.:B#10-16:0.375	HXINDWSH:SP FINISH:701-01002
2	712-3004A	2	ÜCROU HEX.: 5/16-18:GR5:SD:LK	FINISH:701-01000
3	712-3027	1	ÜCROU HEXAGONALE 1/4-20:GRF	FINISH:MTD STD 701-01000
4	720-0309A	1	POIGNÜE PLASTIQUE	FINISH:SCHWARZ
5	731-04074	4	ENTRETOISE PLASTIQUE DE SIEGE	FINISH:SCHWARZ
6	732-0499	1	RESSORT	FINISH:701-01000
7	732-1184	1	RESSORT	500er:FINISH:MTD STD 701-01000
8	736-0175	1	RONDELLE GROWER: .265x.562x.025	FINISH:701-01001
9	736-0204	1	RONDELLE .344 X 62 X.03	FINISH:MTD STD 701-01000
10	736-0696	1	RONDELLE DIN 1440	AD25 x ID12 X 3 (24.6484.25)
11	736-3019	2	RONDELLE .531x1.062x.134:HT	FINISH:736-3019-Z
13	738-0137A	1	VIS j ÜPAULE .340 X .285:1/4-2	738-0137A
14	738-0296	2	AXE EPAULE	FINISH:701-01000
15	738-0966	4	GOUJON FILETÜ	738-0966 / 938-0966
16	783-0611	1	ARRt: AJUSTAGE DE SIEGE	FINISH:PHOS & OIL
17	783-0738B	1	SUPPORT DE SIEGE	
18	783-0739A	1	LEVIER DE RÜGLAGE	FINISH:LACKIERT
19	783-0753	1	CREMAILLERE REGLAGE SIEGE	FINISH:SPEC 701-01000
20	783-1366	1	PATTE CONTACTEUR	VERZINKT

www.emmotoculture.com

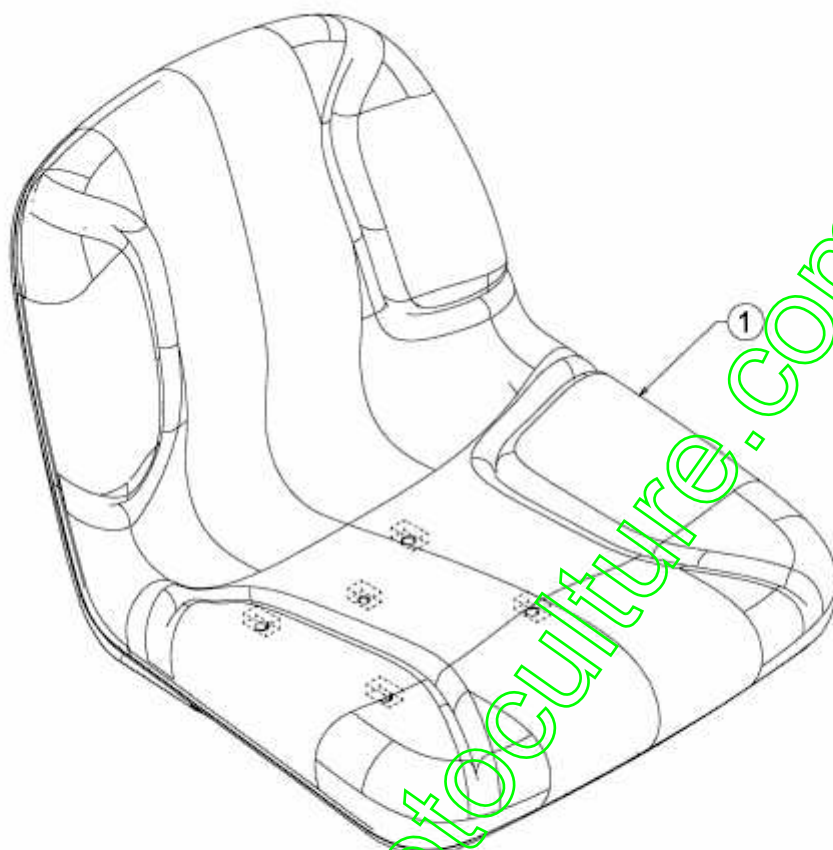

www.emc-motoculture.com

E3-02088A-01

Position	Numéro de lapièce	#	Appellation I	Appellation II
1	757-04003	1	SIEGE HAUT NOIR	757-04003

www.emc-motoculture.com

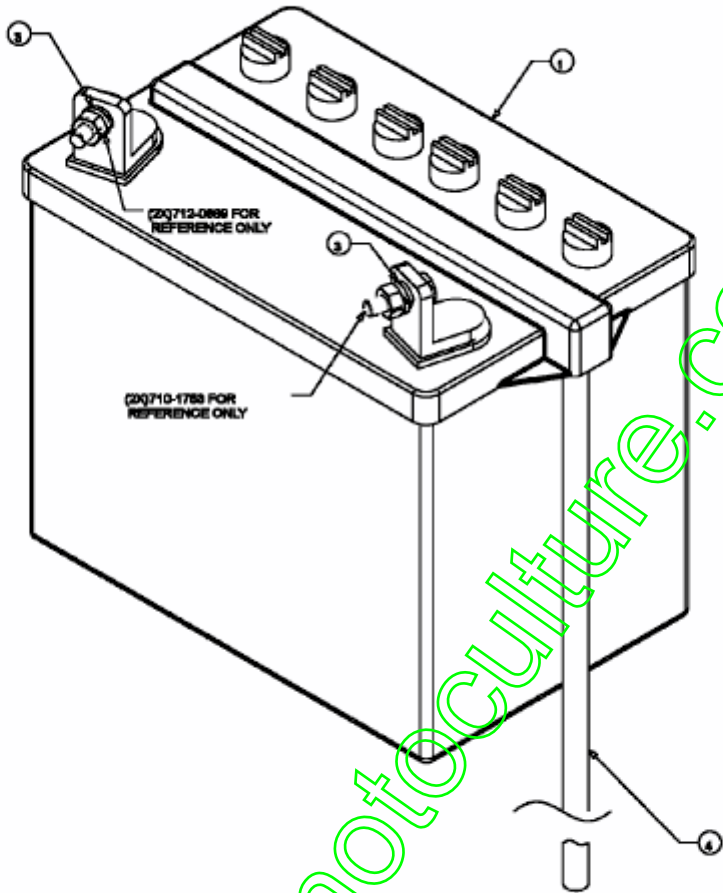

Position	Numéro de lapièce	#	Appellation I	Appellation II
1	725-2057	1	BATTERIE	U1-9 (725-1707D)
3	736-0648	2	RONDELLE GROWER	FINISH:SPEC-100016 24.8195.14
4	750-04016	1	TUYAU D'AÜRATION BATTERIE	6-0.5x1x700 PVC glasklar

www.emc-motoculture.com

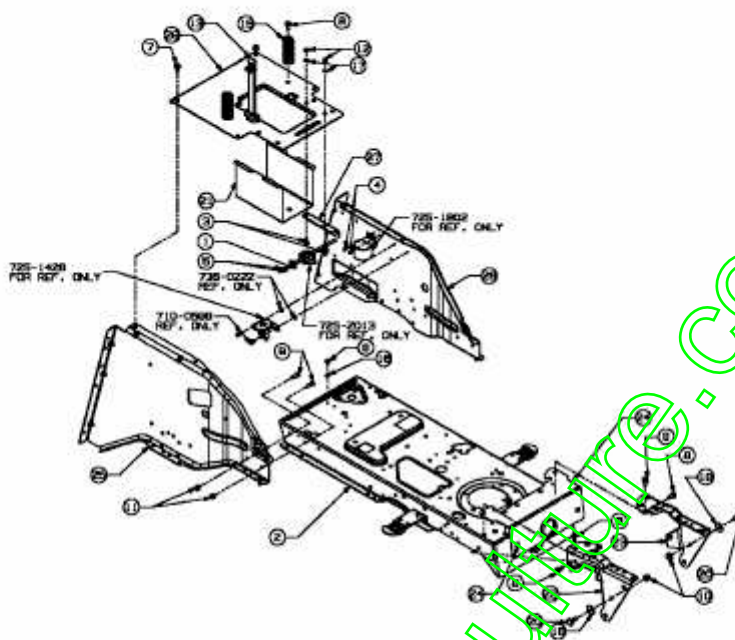

E3-02027A-01

www.emc-motoculture.com

Position	Numéro de lapièce	#	Appellation I	Appellation II
1	17962	1	PLAQUE DE SUPP. P. COMMUTATEUR	FINISH:WIE GESTANZT
2	683-04115	1	CHASSIS	SCHWEIßTEIL
3	710-0134	2	VIS i TATE PLATE	FINISH:MTD STD 701-01000
4	710-0148	2	VIS	FINISH:701-01002 910-0148
5	710-0224	2	VIS PARK:#10- 16:0.500:HXINDWSH	FINISH:MTD STD 701-01002
6	710-0599	1	VIS i SIX PANS CREUX	MTD SPEC-701-01002 or 101617
7	710-0726	2	VIS 5/16- 12:0.750:HXINDWS	FINISH:MTD STD 701-01002
8	710-1260A	8	VIS TT:5/16-18:.750 HXINDWSH	LAGERGEH.MESSERWELLE:701- 01002
9	710-1681	6	VIS i SIX PANS CREUX	MTD SPEC-100015 21.1441.70
10	712-0431	2	ÜCROU STOP 3/8- 16:GRF	FINISH:MTD SPEC-100015
11	712-0692	6	ÜCROU HEXAGONAL 24.1426.18	FINISH:SPEC-100015 24.1426.18
12	712-3006	2	ÜCROU HEXAGONAL	FINISH:PHOS AND OIL
13	723-0444	1	CEINTURE DE SÜCURITÜ BATTERIE	FINISH:SCHWARZ
15	732-04035	2	RESSORT DE SIEGE	FINISH:701-01000
16	736-0222	1	RONDELLE	FINISH:MTD STD 701-01001
17	736-0329	2	RONDELLE GROWER	FINISH:701-01001 24.8195.16
18	736-0331	2	RONDELLE CONIQUE	FINISH:MTD SPEC-100016
20	738-0143	2	VIS EPAULÉE	FINISH:MTD SPEC 100015 (EU)
21	783-0349	1	BOÏTIER DE BATTERIE	FINISH:LACKIERT SCHWARZ *
22	783-0726C	1	SUPPORT D'ESSIEU DROIT	FINISH:LACKIERT
23	783- 0727C637	1	783-0727A650	FINISH:LACKIERT / SCHWARZ LACK
24	783-0728	1	SUPPORT AVANT	783-0728
25	783- 1318A637	1	CHASSIS ARRIÈRE i DROITE	SCHWARZ LACKIERT
26	783- 1370C637	1	SCHWARZ LACKIERT	SCHWARZ LACKIERT
27	783-1387A	1	CADRE SUPP. COMM. DE SIÈGE	VERZINKT
28	783-1410	1	SUPPORT DE SIEGE	F564.021.00

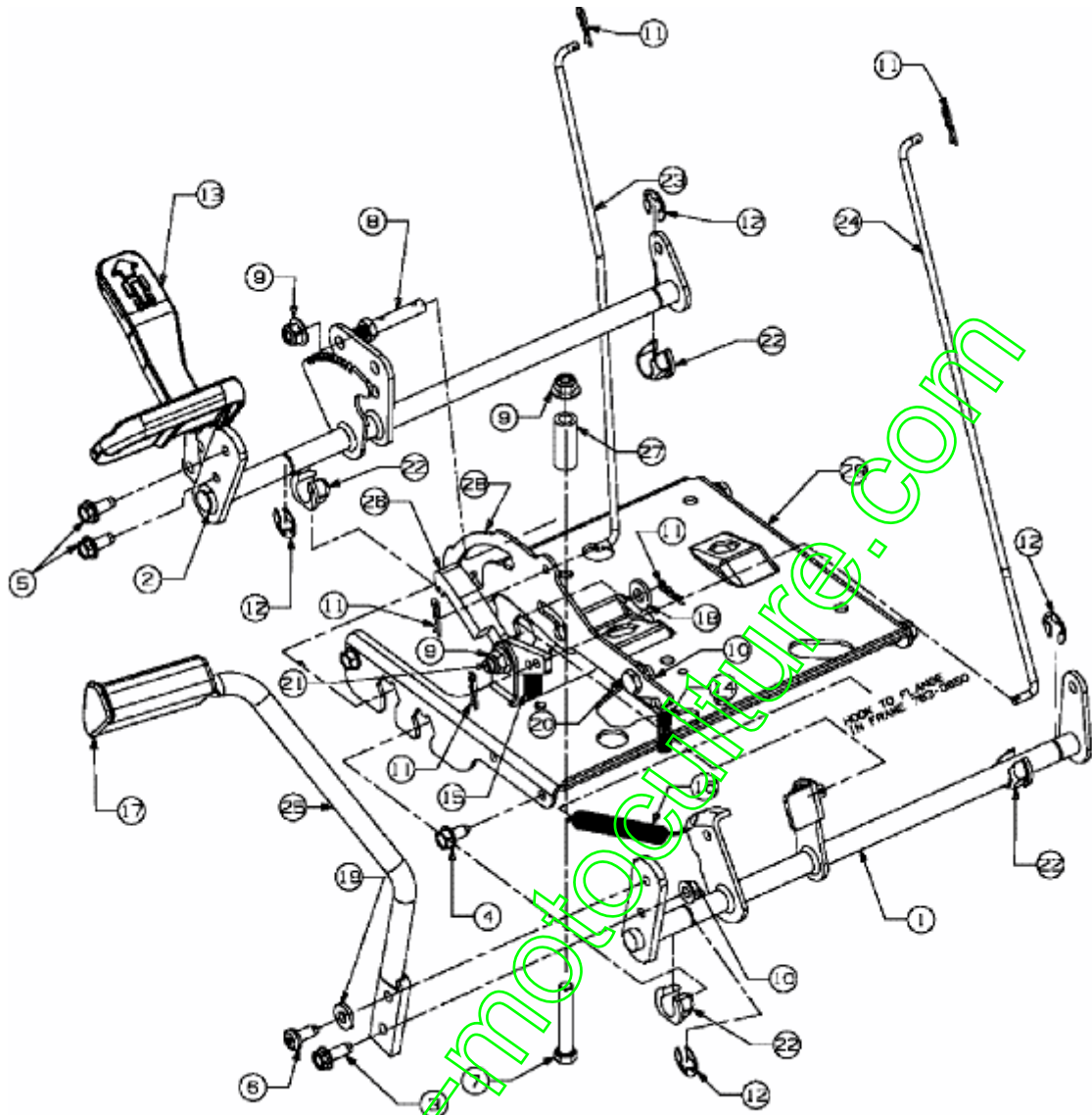

E3-02354B-01

Position	Numéro de lapièce	#	Appellation I	Appellation II
1	647- 0057C637	1	ARBRE DE PÜDALE DE FREIN 500 N	E-TEIL-SET
2	647- 0062C637	1	SCHWEIßTEIL SCHWARZ LACKIERT	SCHWEIßTEIL SCHWARZ LACKIERT
3	710-0650	1	VIS HEX.:TT:5/16- 18:0.875	FINISH:MTD SPEC-701-01002
4	710-0726	4	VIS 5/16- 12:0.750:HXINDWS	FINISH:MTD STD 701-01002
5	710-1260A	2	VIS TT:5/16-18:0.750 HXINDWSH	LAGERGEH.MESSERWELLE:701- 01002
6	710-1611B	1	VIS:TT:5/16- 18:0.750:PANTRXI	FINISH:MTD SPEC-100015
7	710-3011	1	VIS HEX.:3/8- 16:2.25:GR5:STD	FINISH:MTD STD 701-01000
8	711-04159A	1	GOUJON 3/8-16 X 2.68	MIT MUTTER:FINISH:PHOS & OIL
9	712-04065	3	ÜCROU HEXAGONAL	FINISH:SPEC-101616 912-04065
10	712-3004A	2	ÜCROU HEX.: 5/16- 18:GR5:SD:LK	FINISH:701-01000
11	714-0104	5	GOUPILLE	FINISH:PHOS AND OIL
12	716-0106A	4	CIRCLIPS	FINISH:MTD SPEC 701-01001
13	719-0584B	1	PEDALE	FINISH:719-0584B-TW
14	732-0335	1	RESSORT	.405 DIA X 1.17 LG
15	732-0955	1	RESSORT	FINISH:701-01006
16	732-0963	1	RESSORT	SPEC 701-01006 OR 701-01000
17	735-3049	1	GARNITURE DE FREIN i PIED	735-3049
18	736-3004	1	RONDELLE	FINISH:MTD STD 701-01000
19	736-3008	1	RONDELLE	FINISH:MTD SPEC-701-01000
20	738-0155	1	VIS EPAULEE	MTD STD 701-01000 938-0155
21	738-0380	1	AXE	FINISH:701-01000 938-0380
22	741-3065B	4	BAGUE EXAGONALE RAINURÉE	GESCHLITZT:FINISH SCHWARZ
23	747-04093	1	TIGE DE FREIN	
24	747-04096	1	TIGE DE COMMANDE	MTD 701-01006 ODER 701-01007
25	783-0773A	1	PEDALE DE FREIN	783-0773
26	748-04039B	1	BARRIERE GAUCHE	FINISH:GEÖLT ERS.F.748-0413
27	748-0415B	1	ENTRETOISE	.385 ID x .635 OD x1.54
28	783-0663E	1	CONSOLE: FREIN D'ARRÊT: HYDRO	FINISH:SIEHE ZG.
29	783- 1335C637	1	CONSOLE DE SUPPORT: DIRECTION	SCHWARZ LACKIERT

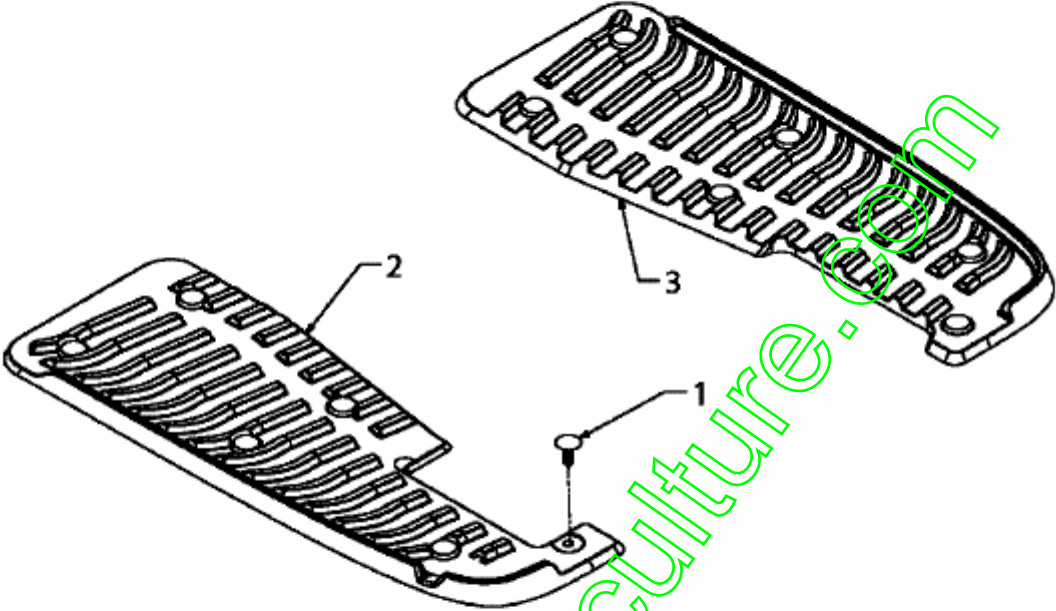

E3-02355A-01

Position	Numéro de lapièce	#	Appellation I	Appellation II
1	726-3046	12	CLIP DE FIXATION:.250 DIA	FINISH:KUNSTSTOFF SCHWARZ
2	735-04050	1	REVETEMENT MARCHE PIED	FINISH:SCHWARZ
3	735-04052	1	REVETEMENT MARCHE PIED	FINISH:SCHWARZ

www.emc-motoculture.com

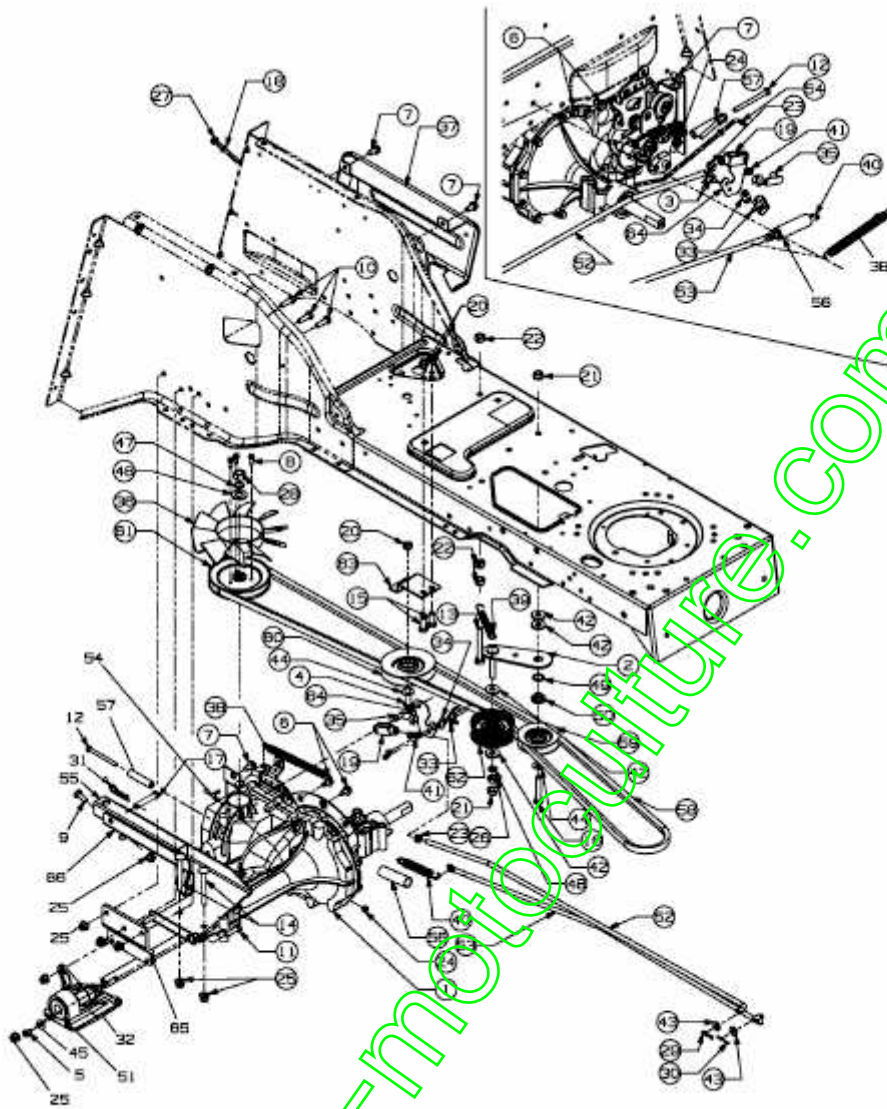

E3-02036B-01

Position	Numéro de pièce	#	Appellation I	Appellation II
1	618-0389A	1	TRANSMISSION	NACHARBEIT ZUS.LOCH AN KONSOLE
2	683-0604A	1	CADRE SUPP. CPL.:GAL. TEND. DB	SCHWEISSTEIL:683-0604A-Z
3	710-0227	2	VIS	FINISH:MTD STD 701-01002
4	710-0344	1	VIS HEX.:3/8-16:1.50:GR5:SPEC	FINISH:701-01000
5	710-0599	1	VIS $\dot{\bar{I}}$ SIX PANS CREUX	MTD SPEC-701-01002 or 101617
6	710-0607	2	VIS HEX.TT5/16-18:.500HXINDWSh	FINISH:MTD SPEC-701-01002
7	710-0726	3	VIS 5/16-12:0.750:HXINDWS	FINISH:MTD STD 701-01002
8	710-1189	3	VIS HEXAGONALE	FINISH:MTD STD 701-01002
9	710-1681	1	VIS $\dot{\bar{I}}$ SIX PANS CREUX	MTD SPEC-100015 21.1441.70
10	710-1682	3	VIS	FINISH:SPEC-100015 21.1441.72
11	710-1683	2	VIS HEX.:M8x30 DIN 933-8.8	FINISH:MTD701-01001 21.1441.74
12	710-1766	1	VIS HEX.	ZN5GL CB (21.1443.60)
13	710-1771	1	VIS HEX.:M10x70 DIN933-8.8	FINISH:MTD 701-01000
14	710-1895	2	VIS	MIT 4KT.-ANS:8.8
15	710-3001	2	VIS HEX. 3/8-16:.880:GR5:STD	FINISH:SPEC-701-01000 910-3001
16	710-3144	1	VIS HEX.: 3/8-16:2.00:GR5:STD	FINISH:STD 701-01000 910-3144
17	711-0679A	1	GOUJON $\dot{\bar{I}}$ ÜPINGLER	FINISH:SIEHE ZG.
18	711-0747	1	GUIDE COURROIE	FINISH:SIEHE ZG.
19	711-1407	1	Tête DE FOURCHE ZN5GL CB DIN71	Zn5glcB 9S20K 28.6218.17
20	712-0375	3	ECROU	FINISH:701-01000
21	712-0431	2	ÜCROU STOP 3/8-16:GRF	FINISH:MTD SPEC-100015
22	712-0637	3	ÜCROU	MTD SPEC 701-101616 24.1426.22
23	712-0690	1	ÜCROU HEXAGONAL	FINISH:MTD701-01000 24.1421.18
24	712-0691	1	ÜCROU HEXAGONAL	MTD SPEC-100015 24.1426.14

Position	Numéro de pièce	#	Appellation I	Appellation II
25	712-0714	8	ÜCROU	FINISH:MTD SPEC-100015
26	712-3017	1	ÜCROU HEXAGONAL	FINISH:701-01000
27	712-3027	1	ÜCROU HEXAGONALE 1/4-20:GRF	FINISH:MTD STD 701-01000
28	712-3066	1	ÜCROU HEXAGONAL 1/2-20 GR5	FINISH:MTD STD 701-01000
29	714-0104	1	GOUPILLE	FINISH:PHOS AND OIL
30	714-0111	1	GOUPILLE FENDUE 3/32:1.0"	FINISH:MTD SPEC-100015
31	714-0147	1	GOUPILLE ; RESSORT:.125 X 1.75	FINISH:SIEHE ZG.
32	719-0534	1	BLOC EMBASE	FINISH:PLAIN
33	725-1773	1	AGRAFE DE SECURITE	FINISH:SIEHE ZG.
34	726-0320	1	PLAQUE D'ISOLATION	FINISH:NATUR ODER SCHWARZ
35	726-0457	1	BOULON: M8-32 DIN 71752	9S20K 25.9425.12
36	731-1449A	1	HELICE DE REFROIDISSEMENT	FINISH:WEISS
37	731-2542A	1	COUVERCLE ARRIERE VERS.LONG.	FINISH:SCHWARZ HINTEN
38	732-0308	1	RESSORT	FINISH:PHOS & OIL
39	732-0429A	1	RESSORT	FINISH:PHOSPHATE AND OIL
40	732-0716	1	RESSORT &&&	732-0716
41	732-0891A	1	RESSORT à PRES.-CONT. D. FREIN	RDF 2020 ROSTFREI
42	736-0258	4	RONDELLE PLATE .385x1.0x.135	FINISH:MTD 701-01000 936-0258
43	736-0275	2	RONDELLE	FINISH:MTD STD 701-01000
44	736-0300	2	RONDELLE	FINISH:MTD SPEC-100015
45	736-0685	1	RONDELLE	MTD SPEC 100015 24.6486.16
46	736-0707	1	RONDELLE	ST 24.6481.28
47	736-0751	1	RONDELLE	13IDx18ADx1.7H
48	736-0755	1	RONDELLE	10 SCHNORR 24.8190.22

Position	Numéro de pièce	#	Appellation I	Appellation II
49	736-0773	1	RONDELLE	24.6273.68
50	738-0372B	1	RONDELLE EPAULEE	FINISH:GEÖLT
51	741-0998	1	ROULEM. j BIL. .75IDX40ODX12	400er HYDRO GETRIEBE
52	747-1301	1	COMMANDE D'EMBRAYAGE	FINISH:GELBVERZINKT, SIEHE ZG.
53	747-1302B	1	TIGE DE FREIN HYDRO 500 LONGUE	FINISH:GELBVERZINKT, SIEHE ZG.
54	747-1315B	1	TIGE:HYDRO:BYPASS:500LWB	LANGER RADSTAND
55	749-04013	1	TUYAU DISPOSITIF D'ATTELAGE	30mm x 30mm x 216 LG LACKIERT
56	750-0802	1	ENTRETOISE / .640IDX.760DX2.63	FINISH:KUNSTSTOFF SCHWARZ
57	750-1329	1	ENTRETOISE	FINISH:GLANZVERZINKT,SIEHE ZG.
58	754-0125A	1	COURROIE TRANSMISSION HYDRO	POLY
59	756-0236	1	GALET TENDEUR	SCHWARZ LACKIERT ODER VERZINKT
60	756-0487	1	GALET TENDEUR	FINISH:FARBE SCHWARZ
61	756-1052	1	POULIE PLATE	400er HYDRO/S.SPERRLAGER
62	756-3054A	1	POULIE TENDEUR	FINISH:SIEHE ZG
63	783-04639A	1	HALTER RIEMENSCHLEIBE:500 HYDRO	FINISH:PAINT
64	783-0786	1	PLAQUE DE CONTACT POUR FREIN	RÜCKWAND HYDRO:GLANZVERZINKT
65	783-1371	1	SUPPORT	FINISH:LACKIERT
66	783-1372	1	SUPPORT D'ATTELAGE	LANGER RADSTAND:LACKIERT

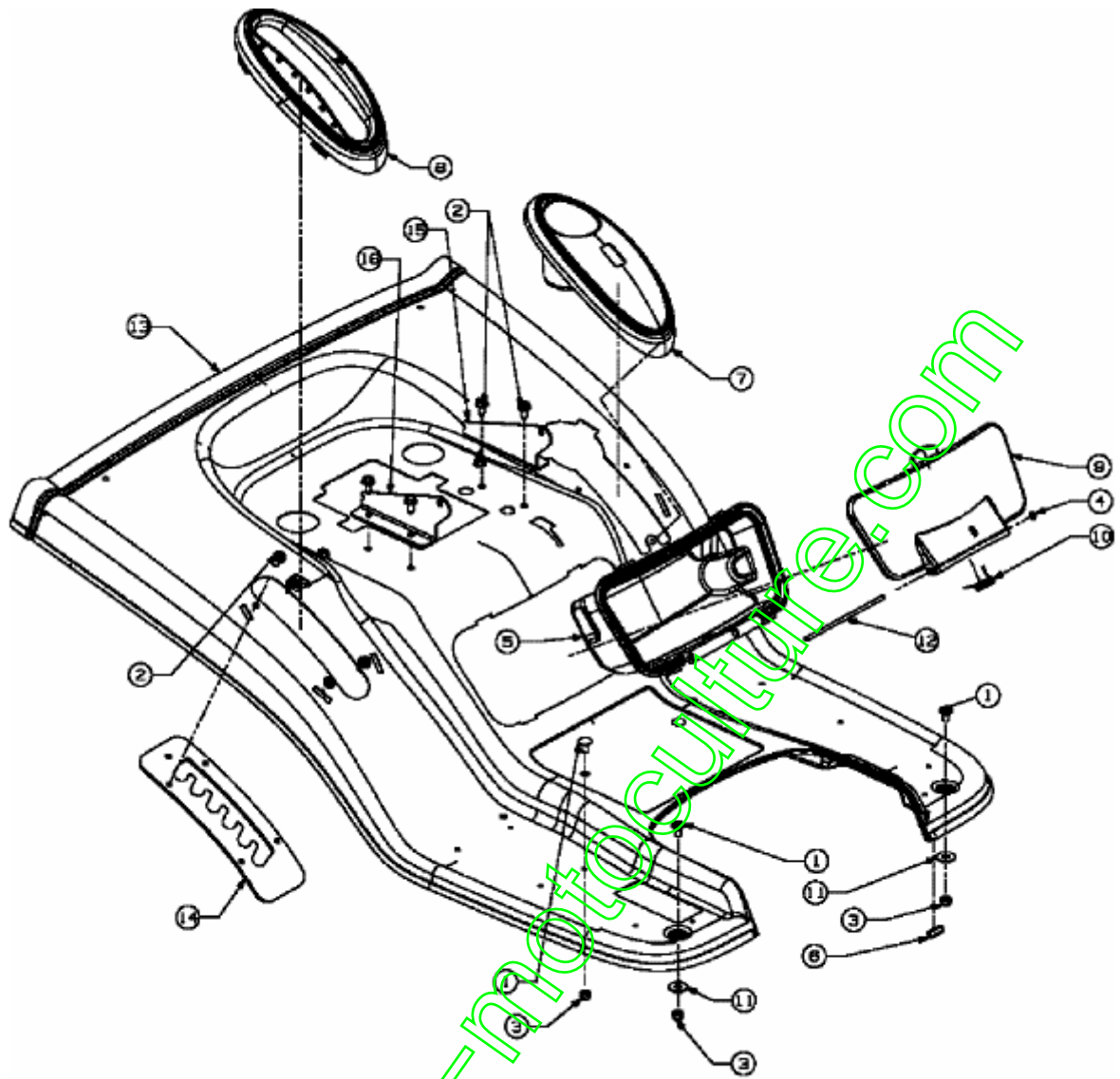

E3-02406A-01

Position	Numéro de pièce	#	Appellation I	Appellation II
1	710-0260A	4	VIS à TÊTE PL. 5/16-18:.62 GR5	FINISH:701-01000
2	710-0726	10	VIS 5/16-12:0.750:HXINDWS	FINISH:MTD STD 701-01002
3	712-0429	4	ÜCROU	FINISH:701-01000
4	726-0111	1	COUVERCLE	FINISH:
5	731-04337	1	WERKZEUGBOX W/O OUTLET	ohne Bohrung
6	731-0511	1	BORDURE DE PROTECTION	FINISH:SCHWARZ, SIEHE ZG.
7	731-05202	1	COUVERCLE:AVEC SUP. DE BOISSON	UND SCHALTER NACHARBEIT
8	731-2546A	1	COUVERCLE DROITE	FINISH:KUNSTSTOFF SCHWARZ
9	731-2561	1	COUVERCLE DE BOÎTE à OUTILS	FINISH:KUNSTSTOFF SCHWARZ
10	732-3150A	1	RESSORT DE TORSION	FINISH:SIEHE ZG.
11	736-3078	2	RONDELLE .344 x 1.00 x .063:HT	FINISH:701-01001
12	747-1307	1	TIGE	FINISH:747-1307-Z
13	783-04617	1	SUPPORT DE SIEGE	WERKZEUGBOX F564.016.00
14	783-1404A	1	PLAQUE SELECTEUR HAUTEUR DE	450/500:FINISH:GLANZVERZINKT
15	783-1496	1	SUPPORT DE SIEGE GAUCHE	FINISH:LACKIERT
16	783-1500	1	SUPPORT DE SIEGE DROIT	FINISH:LACKIERT

www.emc-motoculture.com

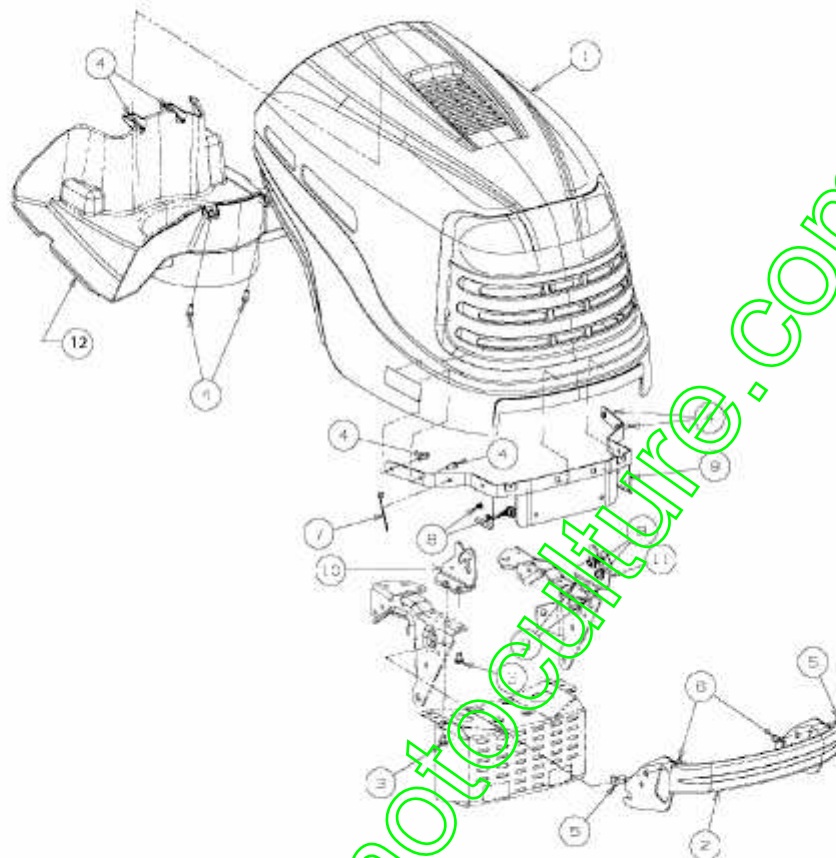

E3-03070A-01

Position	Numéro de lapièce	#	Appellation I	Appellation II
1	631-04224	1	CAPOT CPL.:MASSEY C	COLOR MF-RED
2	683-04338	1	STOSSFÄNGER VOLLST:VORN:4/6/C	SCHWEISSTEIL FINISH:LACKIERT
3	710-0607	4	VIS HEX.TT5/16- 18:.500HXINDWSh	FINISH:MTD SPEC-701- 01002
4	710-0895	8	VIS ; SIX PANS CREUX	FINISH:MTD STD 701- 01002
5	711-0332	2	GOUJON ; ÜPINGLER .50X.78 LG	FINISH:701-01000
6	714-0145	2	GOUPILLE	FINISH:PHOS & OIL
7	725-0157	1	COLLIER DE SERRAGE3/16X0.5X7.4	MATERIAL:NYLON- SCHWARZ
8	738-04091	4	VIS ; ÜPA. .43 x.29:TT:5/16- 18	FINISH:701-01002
9	783-04962	1	SUPPORT CAPOT	783-04962
10	783-04964	1	SUPPORT CAPOT DROITE	783-04964
11	783-04965	1	SUPPOERT CAPOT GAUCHE	783-04965
12	731-04679A	1	CONE PLASTIQUE 1.88 LG	FINISH:SCHWARZ

www.emc-motoculture.com

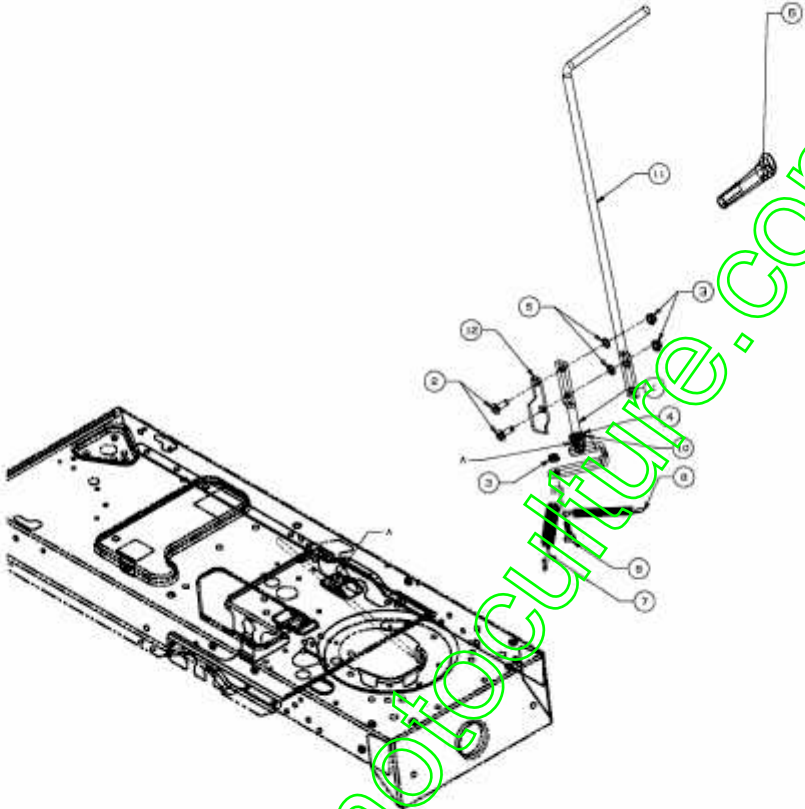

E3-02410A-01

Position	Numéro de lapièce	#	Appellation I	Appellation II
1	647-04045	1	LEVIER PTO MANUEL.500	SCHWESSTEIL:FINISH:647-04045-Z
2	710-0276	2	VIS i T ^α TE PLATE: 5/16-18:1.00	FINISH:701-01000
3	712-3004A	3	ÜCROU HEX.: 5/16-18:GR5:SD:LK	FINISH:701-01000
4	716-0104	1	CIRCLIPS:.500 DIA ARBRE	FINISH:ÖL BENETZT
5	726-0201	2	RONDELLE .3125 ID	FINISH:SPEC-101617
6	731-2111A	1	POIGNEE PTO	SCHWARZ Aufkl. 777I20544
7	732-04000A	1	RESSORT DE TRACTION	
8	732-04174	1	RESSORT.50 OD x 5.0 LG	FINISH:SIEHE ZG.
9	738-0138A	1	VIS EPAULEE	FINISH:MTD STD 701-01006
10	741-0708	1	BAGUE	GESCHLITZT
11	747-04541	1	LEVIER D'ENCLenchEMENT	FINISH:SIEHE ZG.
12	783-1497-Z	1	BARREAU DE JONCTION	VERZINKT

www.emc-motoculture.com

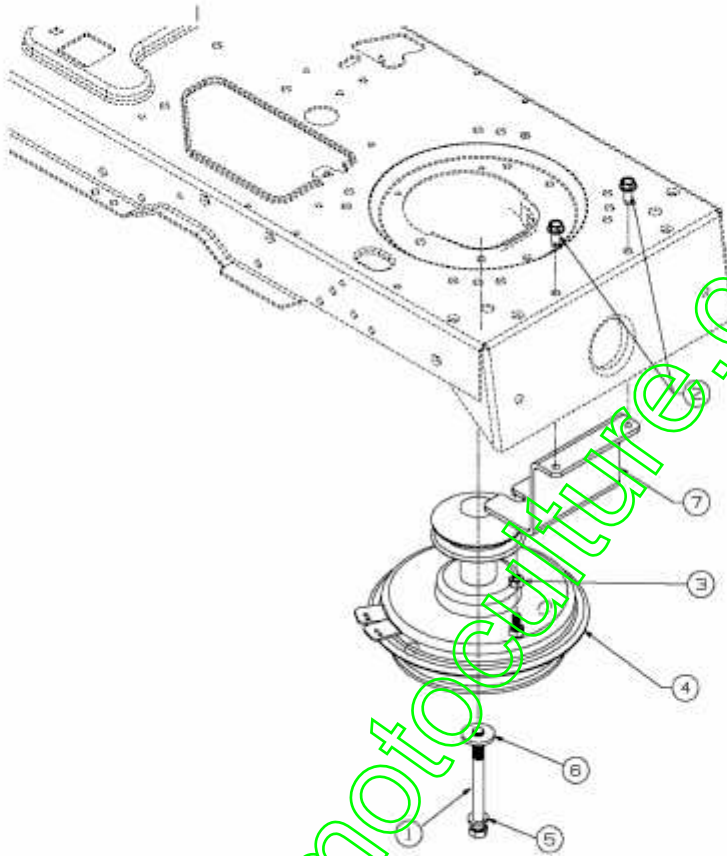

E3-02411A-01

www.emc-motoculture.com

Position	Numéro de lapièce	#	Appellation I	Appellation II
1	710-04002	1	VIS HEX. 7/16- 20:4.50:GR5:STD	FINISH:MTD STD 701-01000
2	710-1260A	2	VIS TT:5/16-18:.750 HXINDWSH	LAGERGEH.MESSERWELLE:701- 01002
3	712-3010	1	ÜCROU HEX. 5/16- 18:GR5	FINISH:MTD SPEC 701-01000
4	717-1788B	1	P T O	500er RIDER GELBVERZINKT
5	736-0171	1	RONDELLE GROWER	FINISH:MTD STD 701-01001
6	736-0322	1	RONDELLE .450 X 1.250 X .164	FINISH:701-01001-936-0322
7	783-05026	1	SUPPORT PTO	FINISH:LACKIERT

www.emc-motoculture.com

E3-03071A-01

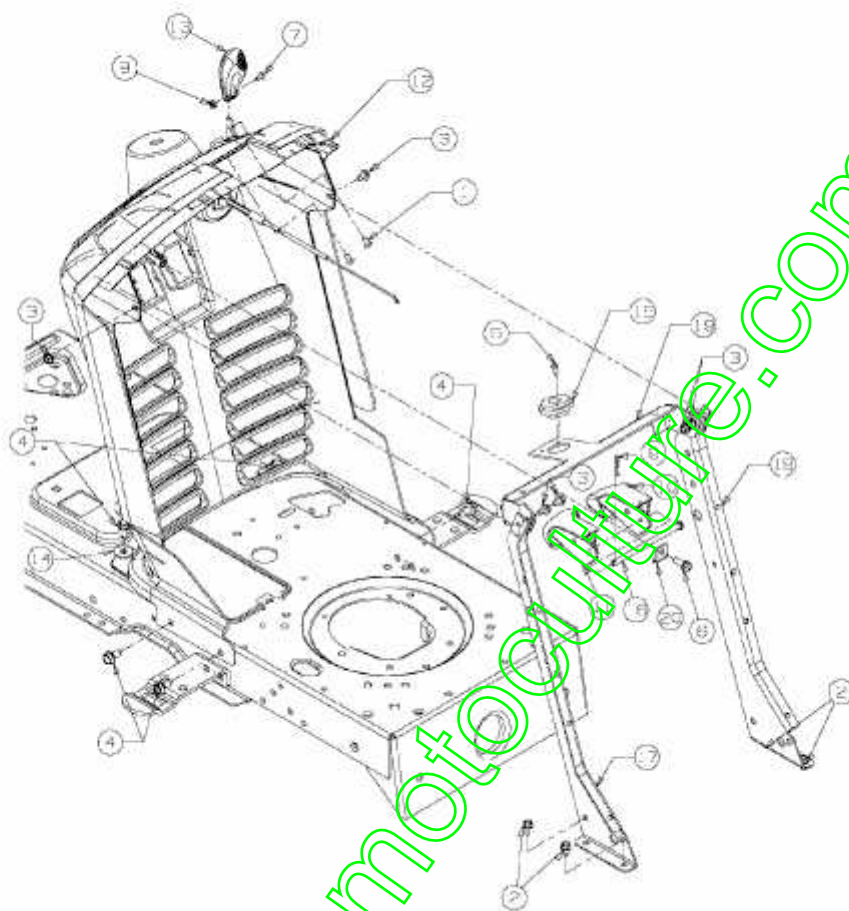

www.emc-motoculture.com

Position	Numéro de pièce	#	Appellation I	Appellation II
1	710-0192	2	VIS 10/24x.38"	FINISH:MTD STD 701-01000
2	710-0599	4	VIS j SIX PANS CREUX	MTD SPEC-701-01002 or 101617
3	710-0653	6	VIS j SIX PANS CREUX	FINISH:MTD SPEC-100016
4	710-0726	5	VIS 5/16-12:0.750:HXINDWS	FINISH:MTD STD 701-01002
5	710-0837	1	VIS	FINISH:MTD STD 701-01002
6	710-0895	1	VIS j SIX PANS CREUX	FINISH:MTD STD 701-01002
7	710-3217	1	VIS	FINISH:701-01000 TRUSPHI
8	712-0142	1	ÜCROU HEX.:#8-32:GRA	FINISH:MTD STD 701-01000
9	714-0104	1	GOUPILLE	FINISH:PHOS AND OIL
10	731-04293A	1	LEVIER:FREIN:TABLEAU DE BORD	CUB 1000 SCHWARZ
11	731-04294A	1	LEVIER	CUB 1000 SCHWARZ
12	731-05585	1	TABLEAU DE BORD:CUB:500 PTO MA	FINISH:SCHWARZ
13	731-1857	1	POIGNÜE	FINISH:KUNSTSTOFF SCHWARZ
14	736-0701	2	RONDELLE	MTD SPEC-100015 24.6486.18
15	741-0587	1	SUPPORT	FINISH:NATUR
16	747-1323A	1	BARRE	FINISH:GLANZVERZINKT
17	783-04285D	1	SUPPORT DROIT	
18	783-04323D	1	LINKS	LINKS
19	783-04729A	1	TRÄGER:ARMATURENBRETT:CUB 500	FINISH:PAINT
20	783-1499	1	ÜQUERRE DE FIXATION:TABLEAU DE	CUB 1500:FINISH: SIEHE ZG.

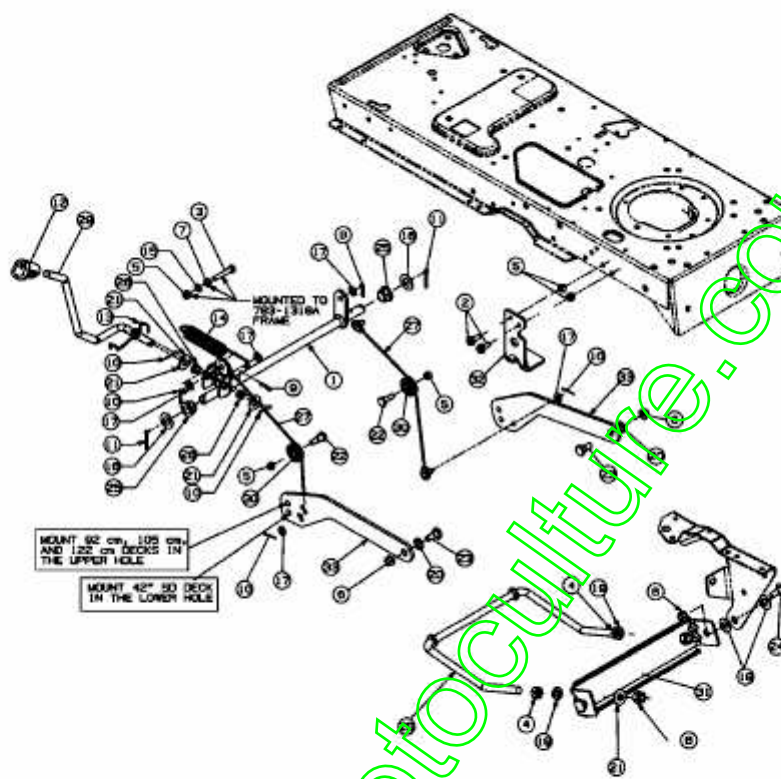

E3-02075A-01

Position	Numéro de lapièce	#	Appellation I	Appellation II
1	683-0587637	1	ARBRE DE RELEVAGE	683-0587
2	710-0604A	2	VIS 5/16-18:0.625	FINISH:MTD SPEC-701-01002
3	710-3180	1	VIS HEX. 5/16-18:1.75:GR5:STD	SPEC-701-01000 or SPEC 101616
4	712-0206	2	ÜCROU HEX. 1/2-13:GR.5	FINISH:MTD STD 701-01000
5	712-0429	5	ÜCROU	FINISH:701-01000
6	712-0431	4	ÜCROU STOP 3/8-16:GRF	FINISH:MTD SPEC-100015
7	712-3010	1	ÜCROU HEX. 5/16-18:GR5	FINISH:MTD SPEC 701-01000
8	712-3083	2	ÜCROU HEX. 1/2-13:GRB:NYLON	FINISH:MTD STD 701-01000
9	714-0104	2	GOUPILLE	FINISH:PHOS AND OIL
10	714-0111	5	GOUPILLE FENDUE 3/32:1.0"	FINISH:MTD SPEC-100015
11	714-0162	2	GOUPILLE FENDUE 5/32:1.25	FINISH:MTD SPEC-100015
12	720-0311	1	POIGNÜE: 1/2	FARBE:SCHWARZ VINYL
13	732-04004	1	RESSORT LEVIER DÜCLENCH. BASS.	500er RIDER
14	732-0971	1	RESSORT	FINISH:OIL & PHOSPHATE
15	736-0119	1	RONDELLE	FINISH:MTD STD 701-01001
16	736-0187	2	RONDELLE .64X1.24X.06	FINISH:MTD SPEC 701-01001
17	736-0275	5	RONDELLE	FINISH:MTD STD 701-01000
18	736-0414	4	RONDELLE TÜFLON	FINISH:WEISS: 936-0414
19	736-0921	2	RONDELLE GROWER	FINISH:MTD STD 701-01001
20	736-3068	2	RONDELLE .531 x.875 x.060	FINISH:MTD STD 701-01000
21	736-3084	4	RONDELLE	FINISH:MTD STD 701-01001
22	738-0138A	2	VIS EPAULEE	FINISH:MTD STD 701-01006
23	738-0143	2	VIS EPAULEE	FINISH:MTD SPEC 100015 (EU)
24	738-0507B	2	VIS	FINISH:PHOS & OIL
25	741-0225	2	BAGUE HEXAGONALE TEFLON 6 PANS	FINISH:KUNSTSTOFF SCHWARZ
26	741-0715	2	BAGUE	741-0715
27	746-1139	2	CABLE DE RELEVAGE 14.06 LG	FINISH:SIEHE ZG.
28	747-1130B	1	ETRIER-RELEVAGE AVANT	5" DIA MTD SPEC 701-01006

Position	Numéro de lapièce	#	Appellation I	Appellation II
29	747-1280	1	LEVIER DE RELEVAGE	FINISH:GLANZVERZINKT
30	756-1154	2	POULIE	FINISH:SCHWARZ
31	783- 0720C637	1	SUPPORT DE RELEVAGE	SCHWARZ
32	783-05540	1	SUPPORT	FINISH:LACKIERT
33	783- 1328A637	2	BRAS DE RELEVAGE - PLATEAU	SCHWARZ LACKIERT

www.emc-motoculture.com

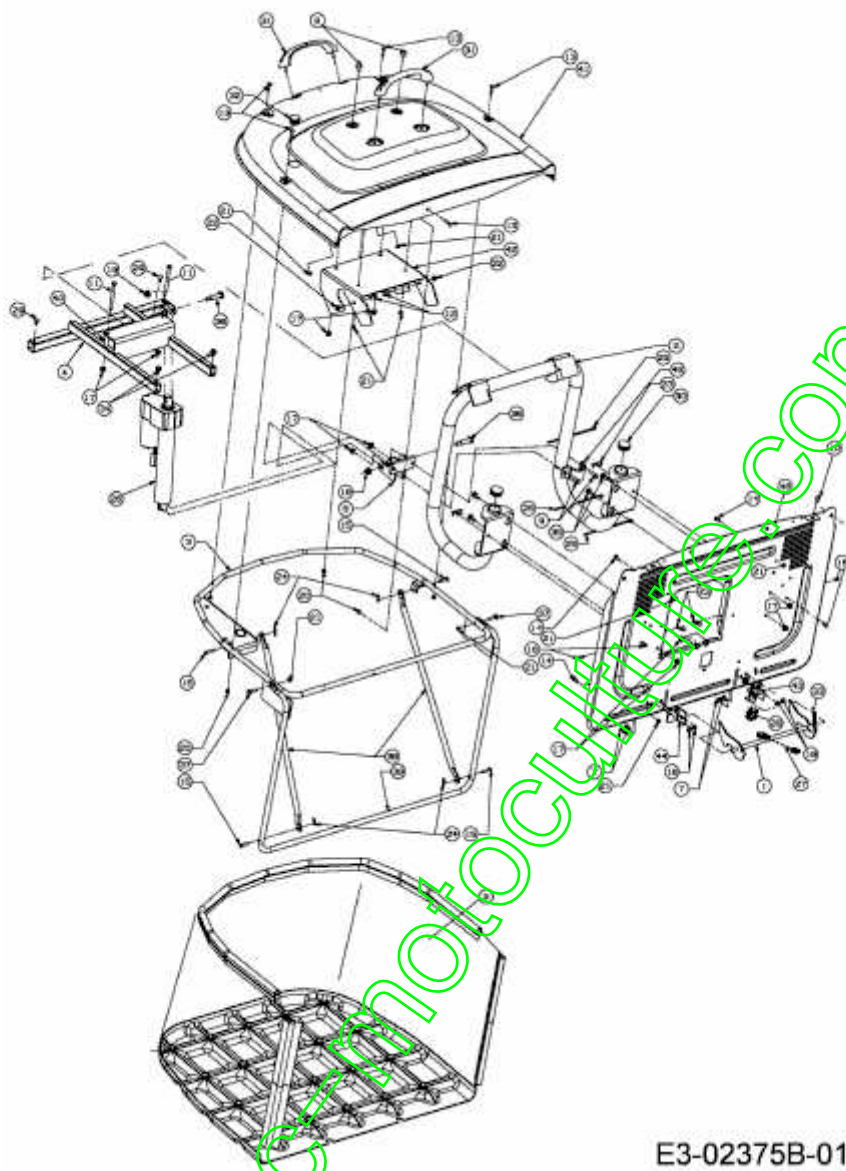

E3-02375B-01

Position	Numéro de lapièce	#	Appellation I	Appellation II
1	647-0063B	1	FERMETURE CPL. BAC	SCHWEISSTEIL:BLAU CHROMATIERT*
2	649-0132	1	TRINGLE DE BAC	SCHWEISSTEIL:FINISH LACKIERT
3	649-04008	1	TRINGLE DE BAC:HAUT 300L	SCHWEISSTEIL:FINISH LACKIERT
4	649-04031	1	ETRIER:VIDANGE BAC ELECTR.	ENTLEERUNG SCHWEIßTEIL PAINT
5	664-0110A	1	TISSU BAC DE RAMASSAGE	300 L 500S:FINISH SCHWARZ
6	683-04179	1	CROCHET D'ACCROCHAGE	SCHWEISSTEIL FINISH PAINT
7	710-0134	4	VIS ; TαTE PLATE	FINISH:MTD STD 701-01000
8	710-0260A	2	VIS ; TαTE PL. 5/16-18:.62 GR5	FINISH:701-01000
9	710-0376	2	VIS HEX.:5/16- 18:1.00:GR5:STD	FINISH:MTD STD 701-01000
10	710-1017	2	VIS	FINISH:MTD SPEC-100016
11	710-1266	2	VIS HHCS:5/16- 18:3.5:GR5:STD	FINISH:MTD STD 701-01000
12	710-1376	2	VIS ; SIX PANS CREUX	FINISH:701-01000 21.1441.68
13	710-1612	5	VIS ; TαTE PLATE:M5x30 DIN 603	FINISH:Zn5glcB 22.3419.03
14	710-1691	3	VIS ; SIX PANS CREUX	FINISH:Zn5glcB 21.1441.45
15	711-04138	4	GOUJON ; ÜPINGLER .25DIAx1.25L	FINISH:SIEHE ZG.
16	711-0701	4	GOUJON	FINISH:SIEHE ZG.
17	712-04063	10	ÜCROU HEX. AVEC FLANC	FINISH:MTD STD SPEC- 101616
18	712-04064	4	ÜCROU HEXAGONAL	GRF:FINISH:701-01000 912- 04064
19	712-04065	2	ÜCROU HEXAGONAL	FINISH:SPEC-101616 912- 04065
20	712-0642	5	ÜCROU DE SÜCURITÜ:M5- 0.8	FINISH:DIN 6926
21	712-0691	9	ÜCROU HEXAGONAL	MTD SPEC-100015 24.1426.14
22	712-0692	2	ÜCROU HEXAGONAL 24.1426.18	FINISH:SPEC-100015 24.1426.18
23	714-0145	4	GOUPILLE	FINISH:PHOS & OIL
24	714-04033	4	GOUPILLE FENDUE .072 x.92 LG	FINISH:PHOS & OIL
25	725-0157	3	COLLIER DE SERRAGE3/16X0.5X7.4	MATERIAL:NYLON- SCHWARZ
26	725-04247	1	VERIN ELECTR. 8"	DD12-10A5-08-268
27	725-04324	1	ADAPTATEUR VIDANGE BAC	LEERUNG:CUB CADET
28	725-3167	1	COMMUTATEUR	FINISH:SCHWARZ 925-3167

Position	Numéro de lapièce	#	Appellation I	Appellation II
29	726-3046	2	CLIP DE FIXATION:.250 DIA	FINISH:KUNSTSTOFF SCHWARZ
30	731-04048	2	CAPUCHON DE PROTECTION	300L/250L BAG:KUNSTST.SCHWARZ
31	731-04578	2	POIGNEE AVEC VIS	FINISH:SCHWARZ
32	731-05256	1	BOUCHON	GPN 320 GL 32 1-2 SCHWARZ
33	732-0264	1	RESSORT	FINISH:SPEC-701-01006 932-0264
34	735-0271	2	PROTEGE CAOUTCHOUC	FINISH:SCHWARZ
35	738-0140	4	VIS ; ÜP.:.435 x.178-5/16 x.56	FINISH:VERZINKT
36	738-0373	2	VIS ; ÜPAULE .496x1.525:3/8-16	FINISH:MTD STD 701-01000
37	738-1183	2	VIS ; ÜPAULE:9,5mmx5mm:M6- 1x24	FINISH:VERZINKT SIEHE ZG.
38	749-04010	2	SUPPORT:BAC DE RAMASSAGE 250/	/300L
39	749-1412	1	ETRIER AVANT BAC 250/300L	
40	750-0848	2	ENTRETOISE	FINISH:PHOSPHATE & OIL
41	783-04179A	1	CAPOT:BAC DE RAMASSAGE:300L	FINISH:LACKIERT
42	783-04180	1	CONSOLE D'ACCROCHAGE:BAC 300L	FINISH:LACKIERT 783- 04180*
43	783-04622	1	EQUERRE GAUCHE:BAC 450/500	SCHALTER:GRSBG 450/500:LACKIER
44	783-04623	1	EQUERRE:DROITE:BAC 450/500	GRASFANGSACK 450/500:LACKIERT
45	783-04664	1	COLLIER	FINISH:LACKIERT
46	783-04834	1	PLAQUE ARRIERE	FINISH:LACKIERT

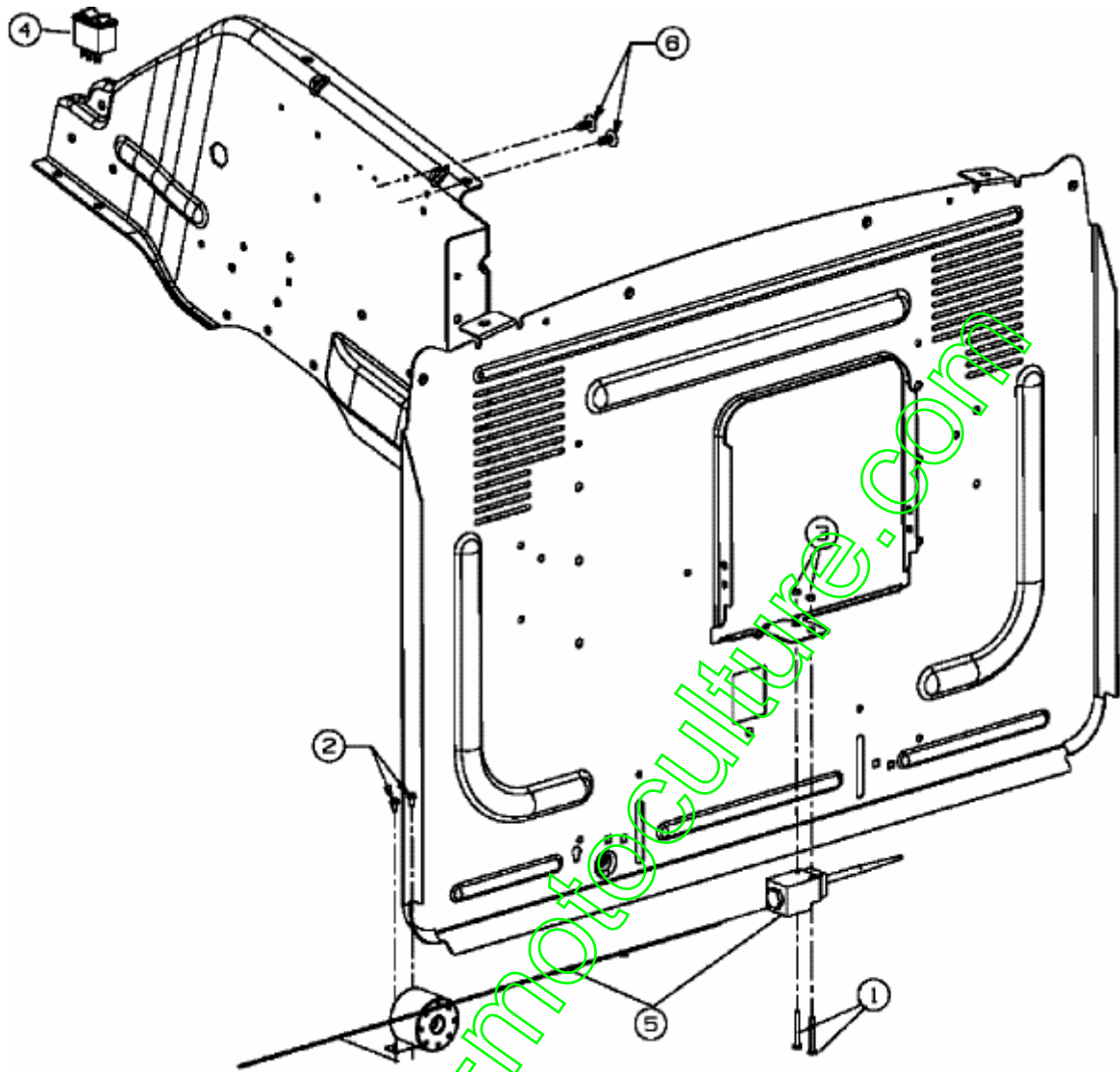

E3-03432A-01

Position	Numéro de lapièce	#	Appellation I	Appellation II
1	710-1397	2	VIS	Zn 5glcB 23.5421.85
2	710-0148	2	VIS	FINISH:701-01002 910-0148
3	712-0636	2	ÜCROU HEXAGONALE	MTD SPEC-100015 24.1426.09
4	725-04263	1	INTERRUPTEUR	LEERUNG FINISH:MATTE BLACK
5	725-04519	1	FAICEAU INDICATEUR REPLISSAGE	725-04519
6	726-3046	2	CLIP DE FIXATION:.250 DIA	FINISH:KUNSTSTOFF SCHWARZ

www.emc-motoculture.com

E3-03076A-01

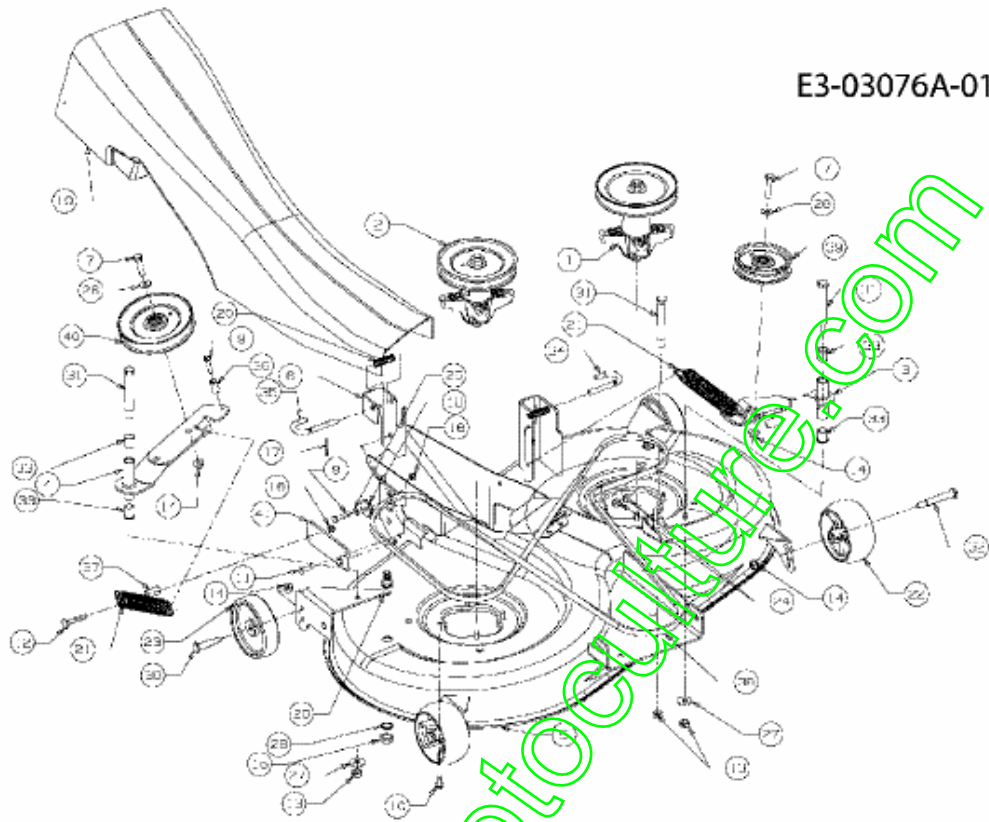

Position	Numéro de pièce	#	Appellation I	Appellation II
1	618-0609	1	PALIER LAME COMPLET GAUCHE	MIT KEILRIEMENSCHLEIBE
2	618-0624	1	PALIER DE LAME CPL. 6.3 DIA.	RIEMENSCHLEIBE
3	683-04058A	1	SUPPORT CPLT	N-DECK 500 SCHWEIßEN-HAND
4	683-04061	1	SUPPORT	DECK 500 S SCHWEIßTEIL
5	683-04330	1	CARTER DE COUPE 105CM ROUGE	SCHWEISSTEIL FINISH:LAGKIERT
6	683-0596	1	SUPPORT	683-0596-0637
7	710-0347	2	VIS HEX. 3/8-16:1.75:GR5:STD	FINISH:MTD STD 701-01000
8	710-0528	1	VIS HEX. 5/16-18:1.25:GR5:STD	FINISH:STD 701-01000 910-0528
9	710-0778	1	VIS HEX. TT:1/4-20:1.500	FINISH:MTD SPEC-701-01002
10	710-1260A	8	VIS TT:5/16-18:.750 HXINDWSH	LAGERGEH.MESSERWELLE:701-01002
11	710-1681	2	VIS j SIX PANS CREUX	MTD SPEC-100015 21.1441.70
12	710-1719	1	VIS j Tête PLATE M8X50 DIN 603	MTD-SPEC-100015 22.3419.32
13	712-0290	3	ÛCROU 7/16-14	FINISH:MTD STD 701-01000
14	712-04065	6	ÛCROU HEXAGONAL	FINISH:SPEC-101616 912-04065
15	712-0641	2	ECROU HEX. M16-1.5 DIN 936	FINISH:701-01000 24.1424.31
16	712-0692	3	ÛCROU HEXAGONAL 24.1426.18	FINISH:SPEC-100015 24.1426.18
17	714-0470	2	EPINGLE EX AF-43010	FINISH:SPEC-100015 470 32 32
18	717-04074	1	PIGNON HAUTEUR PLATEAU	FINISH:SIEHE ZG. 917-04074
19	731-2539A	1	CANAL D'ÛJECTION ARRIÈRE	DECK 105 CM SCHWARZ
20	732-0306A	2	RESSORT DE PRESSION	FINISH:MTD SPEC 701-01000
21	732-04099	2	RESSORT	FINISH:SIEHE ZG.
22	734-04155	2	ROUE DE PLATEAU	FINISH:SIEHE ZG
23	734-0973	2	ROULETTE DE PLATEAU	FINISH:KUNSTSTOFF SCHWARZ
24	735-0271	2	PROTEGE CAOUTCHOUC	FINISH:SCHWARZ
25	736-0119	1	RONDELLE	FINISH:MTD STD 701-01001
26	736-0300	2	RONDELLE	FINISH:MTD SPEC-100015

Position	Numéro de pièce	#	Appellation I	Appellation II
27	736-04097A	2	RONDELLE:PLATE:11.65x28.75x3mm	FINISH:MTD SPEC 701-01000
28	736-0760	2	RONDELLE 17X23.8X1.95	FINISH:MTD STD 701-01001
29	737-04003C	2	GICLEUR	FINISH:FINIDIP 140 -VERZINKT-
30	738-0373	2	VIS ; ÜPAULE .496x1.525:3/8-16	FINISH:MTD STD 701-01000
31	738-0476	3	VIS ; ÜPAULE .625x3.50:7/16-14	PHOS & OIL / ODER SPEC 101616
32	738-3056	2	AXE DE ROUE DE PLATEAU	MTD STD 701-01000 938-3056
33	741-0591	4	BAGUE	FINISH:NATUR 941-0591
34	747-04116A	1	TRINGLE .375 DIA	FINISH:GLANZVERZINKT
35	747-1116	1	GOUPILLE	FINISH:PHOS & OIL COATING
36	750-04182	1	ENTRETOISE	FINISH:SIEHE ZG.
37	750-04195	1	DOUILLE DE DIST. Ø16xØ8x27LG	DIN 2391:ST35:FINISH 701-01000
38	754-04069	1	COURROIE	FINISH:
39	756-04049	1	POULIE DE COURROIE TRAPÜZ.	KUGELGELAGERT: SCHWARZ LACKIERT
40	756-04050	1	POULIE DE COURR. TR. Ø 6.0"DIA	KUGELGELAGERT: SCHWARZ LACKIERT
41	783-04255	1	COMMANDE D'ARRET	FINISH:LACKIERT

www.emc-motoculture.com

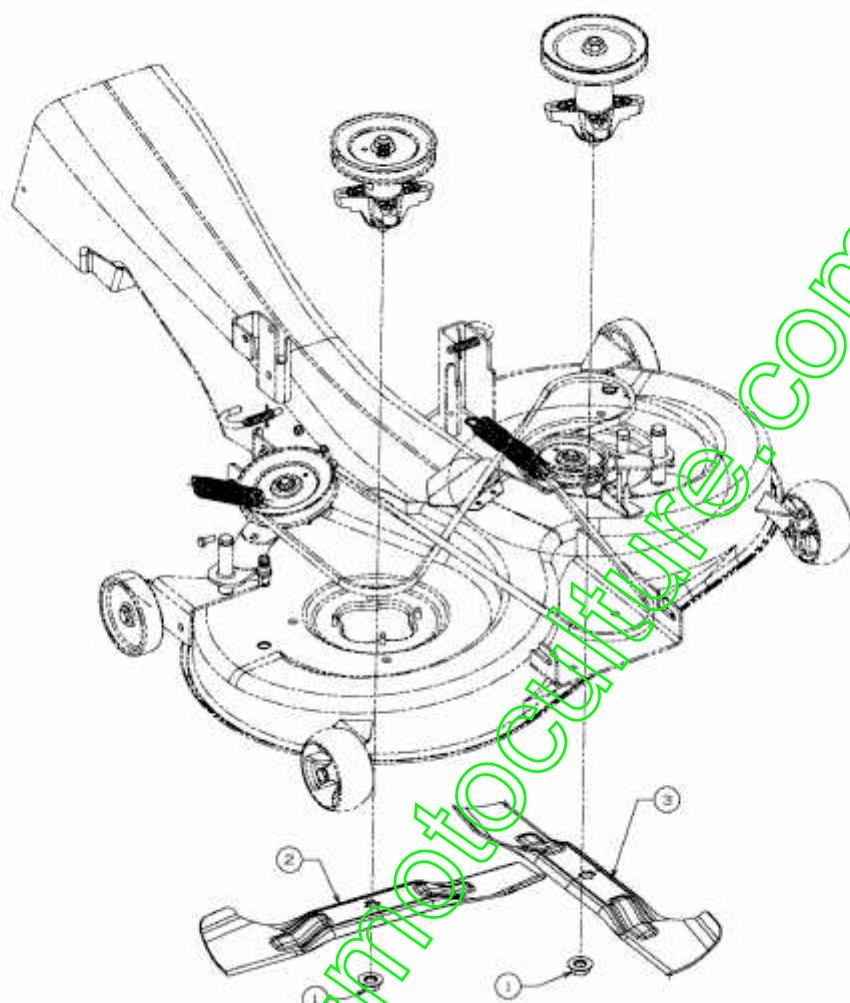

E3-03077A-01

www.emc-motoculture.com

Position	Numéro de lapièce	#	Appellation I	Appellation II
1	712-0417A	2	ÜCROU HEX. AV. FLANC: 5/8-18	FINISH:MTD STD 701-01000
2	742-0670A	1	LAME DROITE SFF 105CM ARR	STAR BAG:FINISH HITZEBEHANDELT
3	742-0671A	1	LAME GAUCHE SFF 105CM ARR	STAR BAG:FINISH HITZEBEHANDELT

www.emc-motoculture.com

[MF 41-20 RD](#) > [13AE51CN695 \(2007\)](#) >
[Couvercles de protection plateau de coupe E \(36"/92cm\), N \(41"/105cm\)](#)

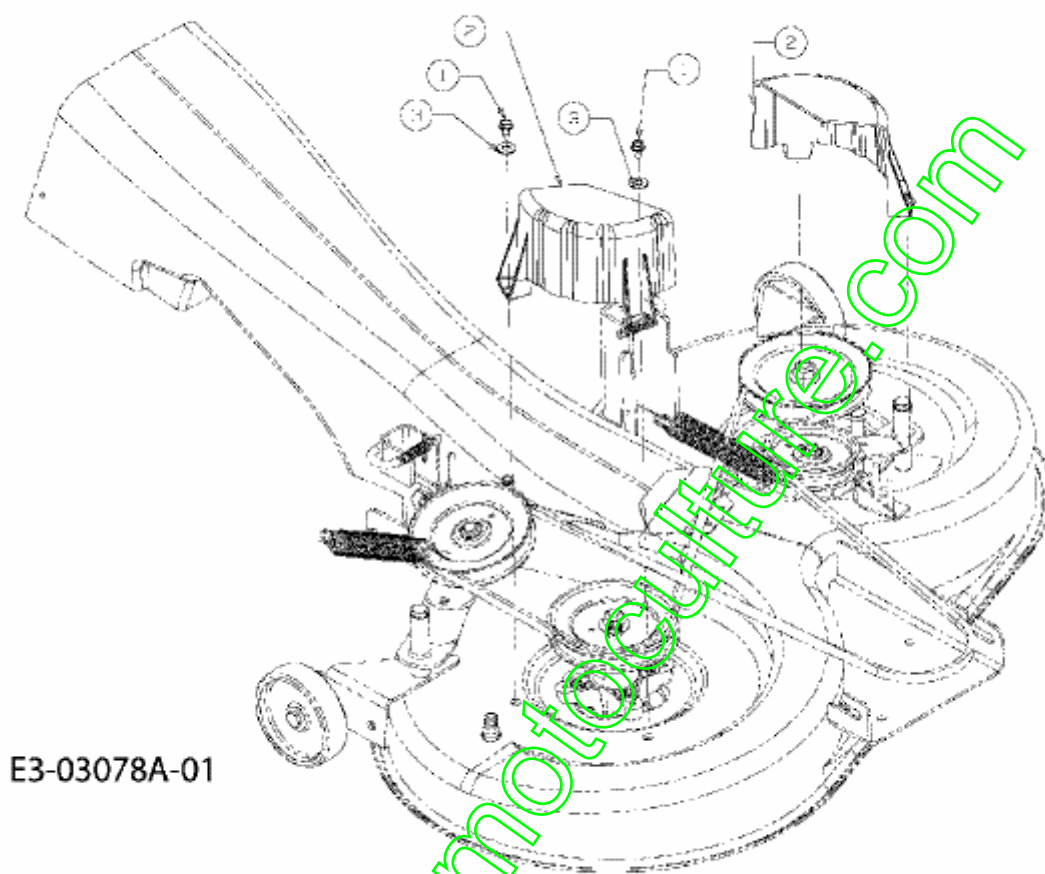

E3-03078A-01

Position	Numéro de lapièce	#	Appellation I	Appellation II
1	710-0607	4	VIS HEX.TT5/16- 18:.500HXINDWSh	FINISH:MTD SPEC-701- 01002
2	731-2538	2	PROTECTION COURROIE DE LAME	92CM/105CM FINISH:SCHWARZ (ZW)
3	736-0300	4	RONDELLE	FINISH:MTD SPEC-100015

www.emc-motoculture.com

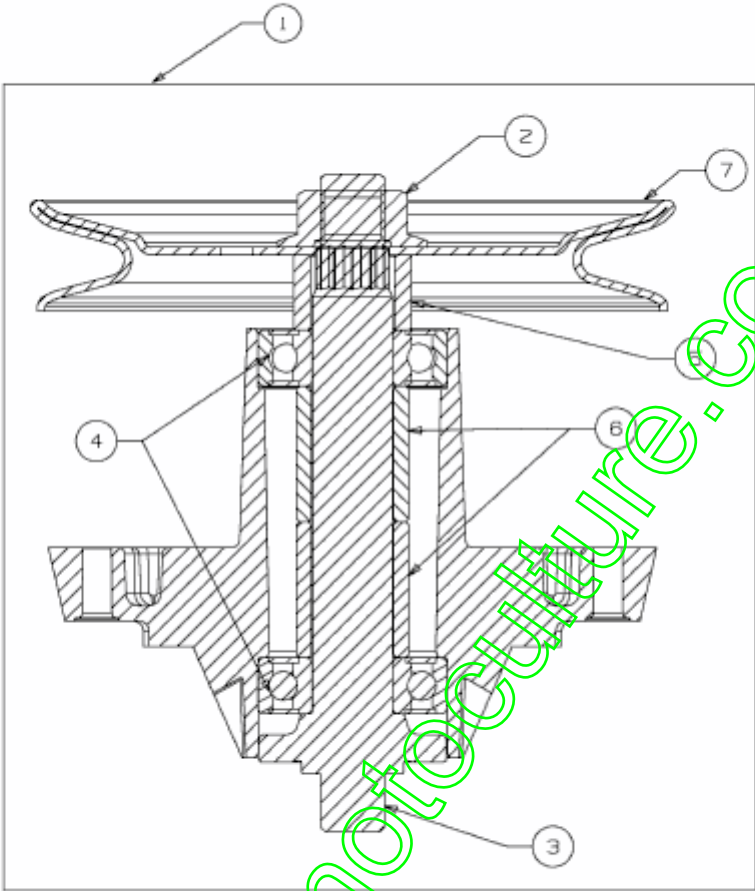

E3-01703A-01

Position	Numéro de lapièce	#	Appellation I	Appellation II
1	618-0624	1	PALIER DE LAME CPL. 6.3 DIA.	RIEMENSCHIEBE
2	712-0417A	1	ÜCROU HEX. AV. FLANC: 5/8-18	FINISH:MTD STD 701- 01000
3	738-1010	1	AXE DE PALIER DE LAME	FINISH:GEÖLT
4	741-0919	2	ROULEMENT ; BILLES	FINISH:SIEHE SPEC.
5	748-0433	1	DOUILLE .820 x 1.150 x .730 LG	FINISH:GEÖLT
6	750-1000	2	ENTRETOISE:.80x1.10x1.330	FINISH:GEÖLT
7	756-1227	1	POULIE DE PALIER DE LAME	FINISH:SIEHE ZG.

www.emc-motoculture.com

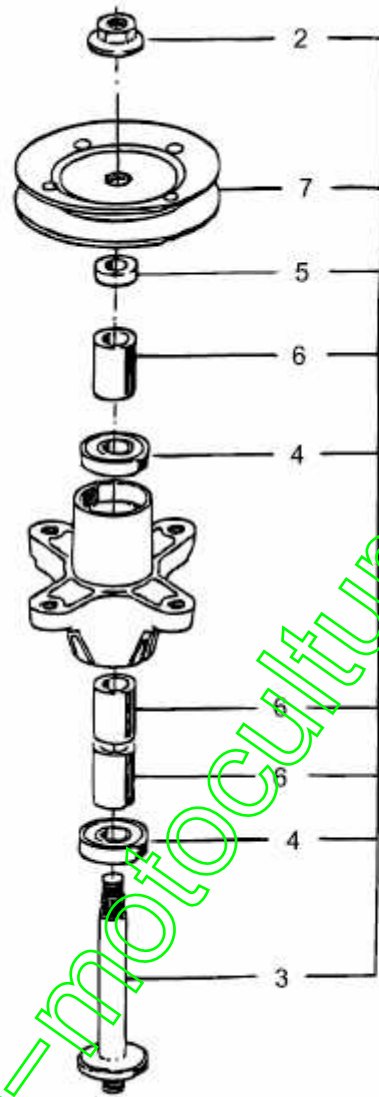

E3-01670A-01

www.emc-motoculture.com

Position	Numéro de lapièce	#	Appellation I	Appellation II
1	618-0609	1	PALIER LAME COMPLET GAUCHE	MIT KEILRIEMENSCHLEIBE
2	712-0417A	1	ÜCROU HEX. AV. FLANC: 5/8-18	FINISH:MTD STD 701- 01000
3	738-1128	1	AXE DE PALIER DE LAMES:6.58"	FINISH:GEÖLT
4	741-0919	2	ROULEMENT j BILLES	FINISH:SIEHE SPEC.
5	748-0434	1	ENTRETOISE	FINISH:GEÖLT
6	750-1000	3	ENTRETOISE:.80x1.10x1.330	FINISH:GEÖLT
7	756-1218	1	POULIE DE PALIER DE LAME	Ø6.482xØ.5625:FINISH SIEHE ZG.

www.emc-motoculture.com

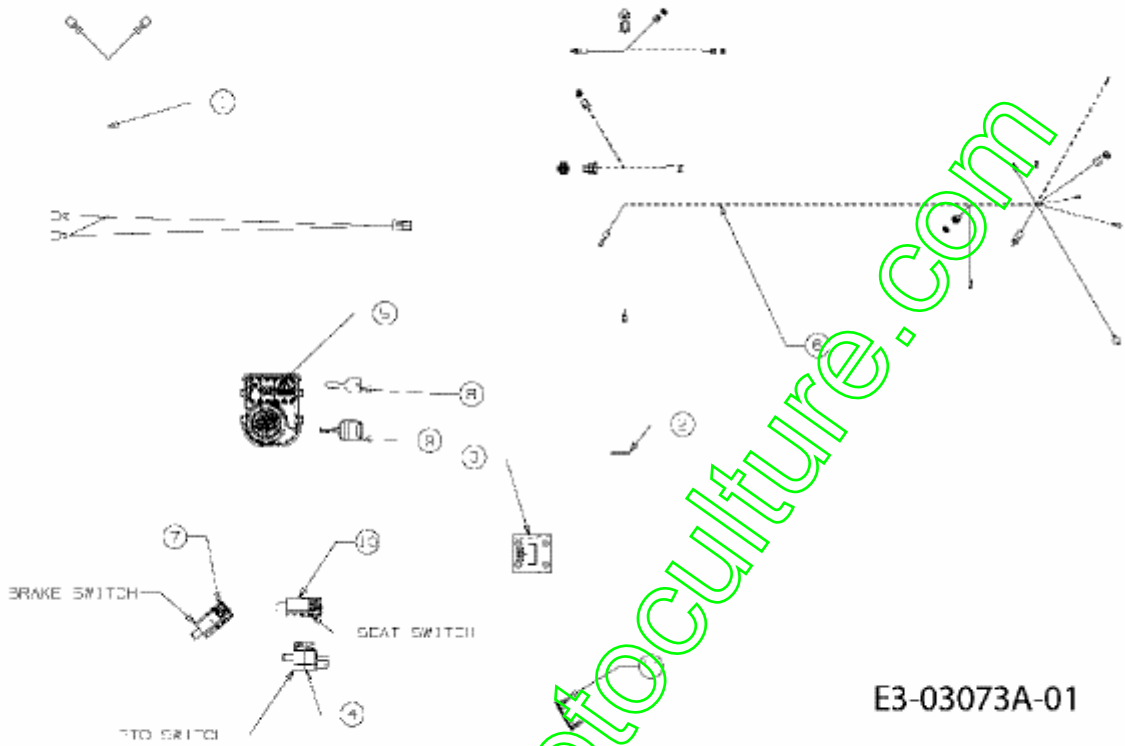

E3-03073A-01

Position	Numéro de lapièce	#	Appellation I	Appellation II
1	629-04133A	1	FAISCEAU DE PHARE	UNIVERSAL:LICHT:AG
2	721-0342	1	ISOLANT	
3	725-04036C	1	COMPTEUR HORAIRE	BETRIEBSSTUNDENZÄHLER
4	725-04038	1	SECURITE D EMBAYAGE	NO/NC/NC:KLICKMONTAGE
5	725-04227B	1	CONTACTEUR A CLÜ	925-04227B
6	725-04371	1	FAISCEAU COMPLET	BETRIEBSSTUNDENZÄHLER
7	725-1657A	1	SECURITE D'EMBAYAGE	Sich.Mähwerk+Kuppl. GRAU
8	725-1744	1	CLÜ DE CONTACT:DELTA	725-1744
9	725-1745	1	CLÜ DE CONTACT	DELTA MIT PLASTIK
10	725-2013	1	SECURITE DE SIEGE	FINISH GRAU
11	731-04010	1	COUVERCLE	FINISH:MATT SCHWARZ

www.emc-motoculture.com

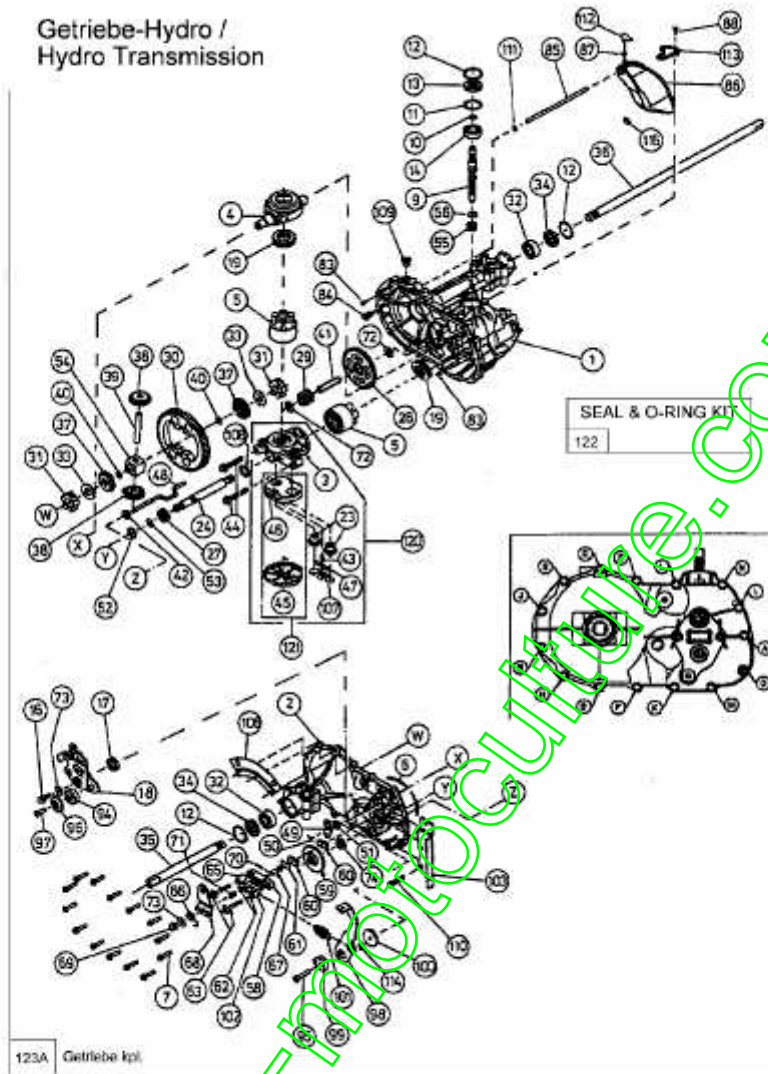

E3-01407B-01

www.emc-motoculture.com

Position	Numéro de lapièce	#	Appellation I	Appellation II
1	HG-70467	1	CARTER DE BOÖTE VITESSES CPL.	HG-70467
2	HG-70468	1	COUVERCLE DE BOÏTIER CPL.	HG-70468
3	HG-70477	1	CORPS DE POMPE	HG-70477
4	HG-51048	1	DISQUE INCLINÜS	HG-51048
5	HG-70331	1	BLOC CYLINDRE CPL.	HG-70331
6	HG-50928	1	JOINT	50928
7	HG-51190	14	VIS HEX.: 1/4-20X1.25	HG-51190
9	HG-51062	1	ARBRE D'ADMISSION	HG-51062
10	HG-2000022	1	CIRCLIPS	HG-2000022
11	HG-50951	1	DOUILLE	HG-50951
12	28.3592.40	3	CIRCLIPS DIN 472	40X1,75 FEDERST.
13	HG-51161	1	BAGUE D'ÜTANCHÜITÜ	0.67X1.58X0.276 94M90298
14	HG-50315	1	ROULEMENT ; BILLES	17MMIDX40MMODX12MM
16	HG-51064	1	VIS HEXAGONALE	1/4-20X1.25
17	HG-51140	1	BAGUE D'ÜT. 18X32X7 DIN 3760	51140/94M90299
18	HG-51119	1	BRAS DE CONTRÖLE	HG-51119
19	HG-50551P	2	PALIER DE BUTÜE	HG-50551P
23	HG-51207	2	BOUCHON	HG-51207
24	HG-50966	1	ARBRE DE MOTEUR	HG-50966
27	HG-51130	1	PIGNON 13 DENTS	HG-51130
28	HG-51129	1	PIGNON	10 ZÄHNE/48 ZÄHNE
29	HG-51043	1	PIGNON	10 ZÄHNE
30	HG-51044	1	PIGNON	60 ZÄHNE
31	HG-51088	2	DOUILLE DE PALIER	0.75X1.75X0.625
32	HG-51089	2	DOUILLE DE PALIER EXTURIEUR	51089
33	HG-44875	2	RONDELLE	3/4 IDX1-1/2 OD
34	HG-51066	2	BAGUE D'ÜTANCHÜITÜ	HG-51066
35	HG-51106	1	ARBRE D'AXE GAUCHE	0.75X0.12 DD
36	HG-51105	1	ARBRE D'AXE DROITE	0.75X21.76
37	HG-44096	2	PIGNON CONIQUE	44096
38	HG-44097	2	PIGNON CONIQUE	15 ZÄHNE 0.5" ID
39	HG-50146	1	ARBRE	HG-50146
40	HG-44871	2	CIRCLIPS	HG-44871 *
41	HG-51083	1	GOUPILLE	HG-51083
42	HG-51100	1	RONDELLE MAGNETIQUE	HG-51100
43	HG-51136	1	RESSORT-BYPASS	HG-51136
44	HG-50016	2	VIS	3/8-24X2.5"LG.
45	HG-70756	1	FILTRE COMPLET	70756
46	HG-70756	1	FILTRE COMPLET	70756
47	HG-51091	1	SCHALTWELLE,BYPASS	HG-51091
48	HG-51098	1	TIGE-BYPASS	HG-51098

Position	Numéro de lapièce	#	Appellation I	Appellation II
49	HG-51135	1	LEVIER DÉRIVATION	51135/94M90225
50	HG-51116	1	CIRCLIPS	0.25" AUßEN
51	HG-51081	1	BAGUE D'ÛTANCHÛITÛ	HG-51081
52	HG-44371	1	RONDELLE	5/8 ID X 1.0 OD X 0.05
53	HG-44145	1	BAGUE DE SÛCURITÛ	44145
54	HG-51071	1	PALIER CENTER BLOCK	HG-51071
55	HG-2003014	1	RESSORT	HG-2003014
56	HG-2003017	1	RONDELLE	HG-2003017
58	HG-62589	1	PLATEAU DE FREIN	HG-62589
59	HG-51072	1	DISQUE DE FREIN	HG-51072
60	717-0678	2	PLAQUETTE DE FREIN	FINISH:
61	717-0682	1	INSERT DE FREIN	FINISH:NONE 917-0682
62	741-0343	2	GOUJON DE PRESSION 5/16"	FINISH:SIEHE ZG. 941-0343
63	HG-51146	2	VIS	1/4-20X2W/PATCH
65	HG-23711	1	DOUILLE	DREHFEDER
66	HG-50884		RESSORT DE FREIN	50884/94M90384
67	HG-44138	1	GOUJON FILETÉ	5/16-24
68	HG-51142	1	LEVIER DE FREIN	51142/94M90209
69	712-0335	1	ECROU CONIQUE 5/16- 24"	712-0335
70	714-0507	1	GOUPILLE FENDUE 3/32 X .750	FINISH:MTD SPEC-100015
71	HG-50919	1	RESSORT DE FREIN	HG-50919
72	HG-50132	2	RONDELLE	HG-50132
73	736-0371	2	RONDELLE 1.344XA .875"	FINISH:701-01001
74	HG-70719	1	KIT DE BAGUE D'ETANCHÉITÉ	70719
83	90048002506	2	BOULON	HG-9004800-2506
84	HG-51143	1	CONNECTEUR	5/16SAE5/32TUBE
85	HG-51147	1	TUYAU	HG-51147
86	HG-70503	1	SET COMPENSATEUR	HG-70503
87	HG-51251	1	COUVERCLE, SOUPAPE	HG-51251
88	HG-50653	1	VIS	10-32 X 1/2
94	HG-44147	1	ROULEMENT À BILLES	0.62 ID X 1.38 X 0.44
95	HG-50837	1	VIS	5/16-24X1-1/2
96	HG-51200	1	DOUILLE	HG-51200
97	HG-50870	1	VIS	HG-50870
98	HG-51120	1	LEVIER DE RELACHE	HG-51120
99	HG-51097	1	PIÈCE DE RÉGLAGE	HG-51097
100	HG-51122	1	RONDELLE	0.325ODX1.60IDX0.150W
101	HG-51131	1	RESSORT DE TRACTION	51131/94M90380
102	HG-51123	1	DOUILLE	0.56ODX0.26IDX0.87
103	HG-51137	1	EQUERRE	HG-51137
106	HG-51138	1	CADRE SUPPORT	HG-51138
107	HG-51134	1	DÉFLECTEUR	HG-51134

Position	Numéro de lapièce	#	Appellation I	Appellation II
108	HG-51069	1	RONDELLE-ARBRE MOTEUR	51069/94M90404
109	90051105600	1	BOUCHON FILETÜ	HG-9005110-5600
110	HG-50868	1	VIS DE TORX	HD 5/16-18
111	HG-51144	1	RONDELLE-O	0.07X0.301ID
112	HG-51252	1	GUIDAGE D'AIR	51252
113	HG-51179	1	PLAQUE D'ARRET	HG-51179
114	HG-51184	1	RONDELLE GROWER	HG-51184
116	HG-51196	1	JOINT	HG-51196
120	HG-70757	1	CORPS HYDRAULIQUE	70757
121	HG-70756	1	FILTRE COMPLET	70756
122	HG-70463	1	JEU DE JOINTS	HG-70463
123A	618-0389A	1	TRANSMISSION	NACHARBEIT ZUS.LOCH AN KONSOLE

www.emc-motoculture.com

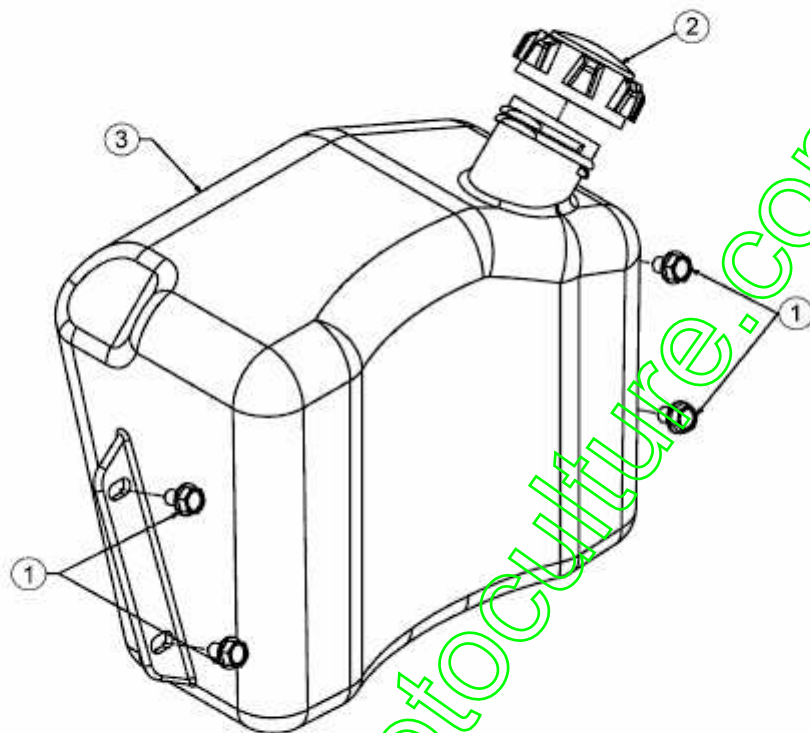

E3-02020A-01

Position	Numéro de lapièce	#	Appellation I	Appellation II
1	710-0604A	4	VIS 5/16-18:0.625	FINISH:MTD SPEC-701-01002
2	751-0603	1	BOUCHON RESERVOIR ESSENCE	FINISH:SCHWARZ
3	751-0818D	1	RESERVOIR ESSENCE: 2.0 GAL	FINISH:NATUR SIEHE ZG.

www.emc-motoculture.com

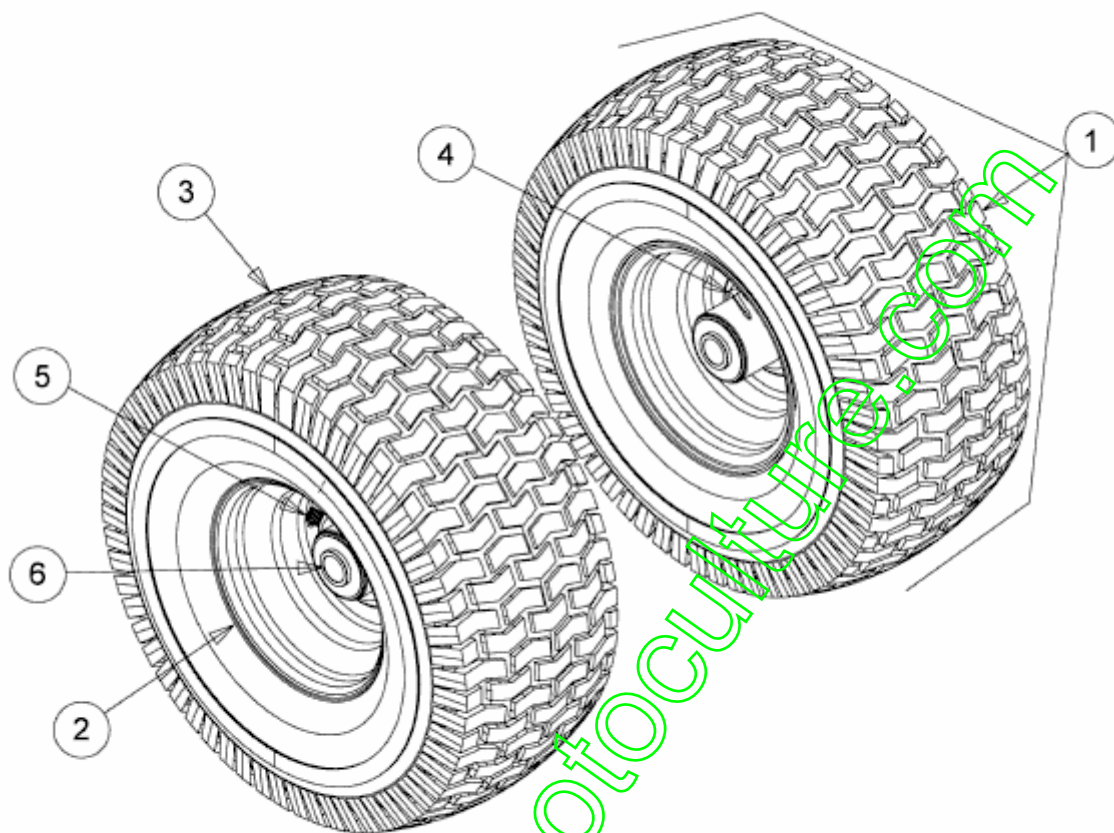

E3-02086B-01

www.emc-motoculture.com

Position	Numéro de lapièce	#	Appellation I	Appellation II
1	634-04199	2	RAD KOMPL:15x6x6:BB KUGELLAGER	FINISH:NONE
2	634-04091	1	JANTE CPLT	
3	734-1731	1	PNEU 15X600X6 DICO MULTI- TRAC	FINISH:
4	737-0224	1	GRAISSEUR JANTE DE ROUE	FINISH:ZINC
5	734-0255	1	VALVE:PNEU	TR 412-P / 32.6mm / 934-0255
6	741-04137	2	ROULEMENT DE ROUE	941-04137*

www.emc-motoculture.com

bis 30.06.2013
to 30.06.2013
jusqu'au 30.06.2013

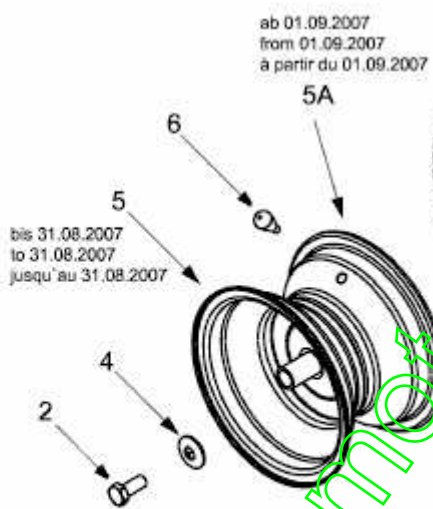
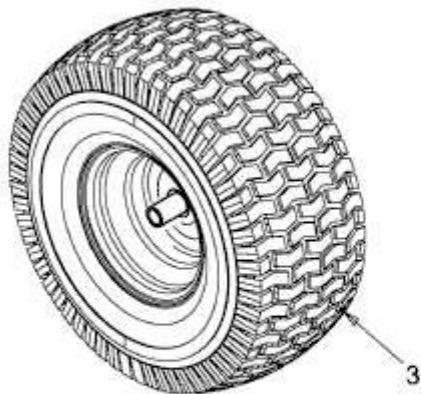

E3-02084B-01

www.emc-motocycle.com

Position	Numéro de lapièce	#	Appellation I	Appellation II
2	710-0627	2	VIS HEX. 5/16-24:.750 GR5:LOCK	FINISH:MTD STD 701- 01000
3	734-0817	2	ROUE COMPL 18X9,50-8 ST ELEC	734-0817662/-674/-WY/- CB
4	736-0242	2	RONDELLE CONIQUE.340X.872X.060	FINISH:MTD STD 701- 01001
5	634-0070	2	JANTE	FINISH:788- 0499/674/0662
5A	634-04369	2	JANTE 8.0x7.0x .750 ID	FINISH LACKIERT
6	734-0255	2	VALVE:PNEU	TR 412-P / 32.6mm / 934-0255
7	734-0448	2	PNEU 18*950*8	734-0448-0901

www.emc-motoculture.com

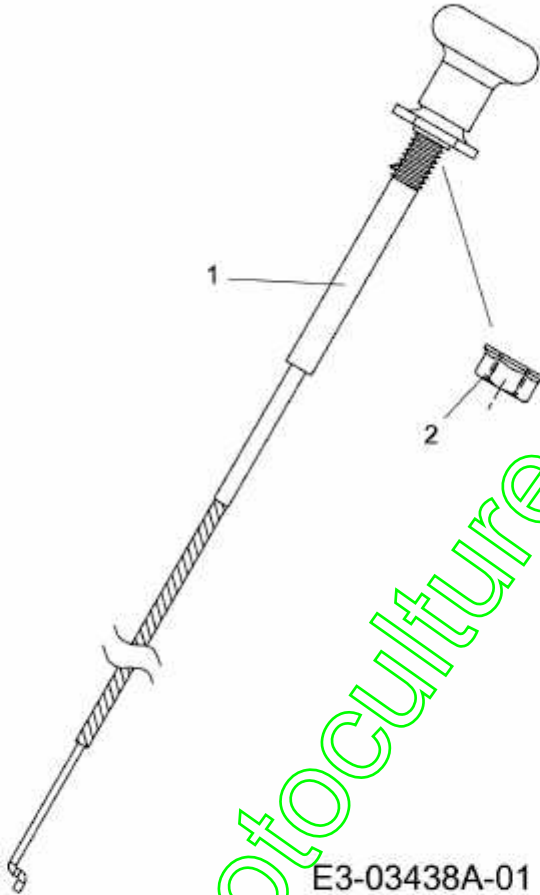

E3-03438A-01

www.emc-motoculture.com

Position	Numéro de lapièce	#	Appellation I	Appellation II
1	746-1085A	1	CøBLE STARTER	37.5" LG x 2.0 EXT
2	712-3005	1	ÜCROU AVEC FLANC:3/8- 16:GR5	FINISH:701-01000 912- 3005

www.emc-motoculture.com

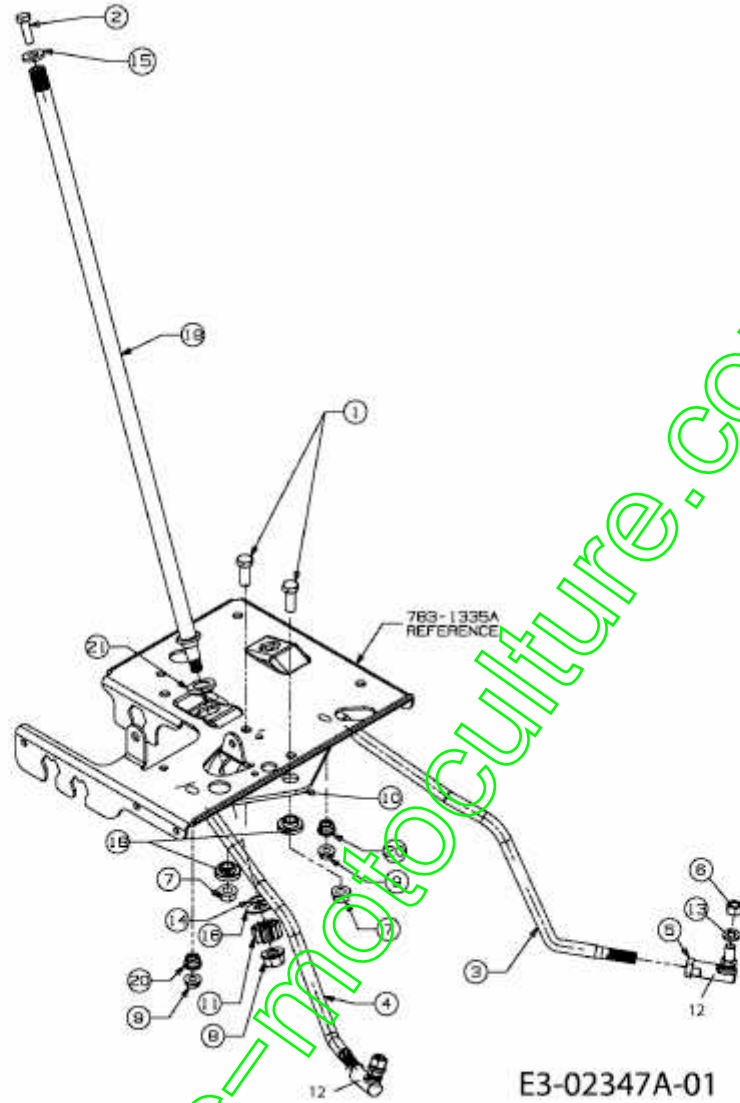

Position	Numéro de lapièce	#	Appellation I	Appellation II
1	710-0514	2	VIS HEX.:3/8- 16:1.00:GR5:STD	FINISH:MTD STD 701-01000
2	710-0643	1	VIS HEX.: 5/16-18:1.00:GR5	FINISH: MTD STD 701- 01000
3	711-1775B	1	TRINGLE REGL. VOIE/GAUCHE	FINISH:SIEHE ZG.
4	711-1776B	1	TRINGLE REGL. VOIE/DROITE	FINISH:SIEHE ZG.
5	712-0240	2	ÜCROU HEX.: 7/16-20:GR2	FINISH:MTD STD 701-01000
6	712-0241	2	ÜCROU HEX.: 3/8-24:GR5	FINISH:MTD STD 701-01000
7	712-0431	2	ÜCROU STOP 3/8-16:GRF	FINISH:MTD SPEC-100015
8	712-0459	1	ÜCROU HEX.: 7/16-20:GRB	FINISH:MTD SPEC-101616
9	712-3004A	2	ÜCROU HEX.: 5/16- 18:GR5:SD:LK	FINISH:701-01000
10	717-1550E	1	SEGMENT DE DIRECTION	14/90 RATIO
11	717-1554	1	PIGNON DE DIRECTION	FINISH:GEÖLT
12	723-0448A	2	ROTULE DE DIRECTION 7/16-20	FINISH:GELB VERZINKT
13	736-0169	2	BAGUE ÜLASTIQUE	FINISH:MTD SPEC-100016
14	736-0770	1	RONDELLE D'AJUSTAGE DIN 988	13X19X0.3 ST
15	736-3004	1	RONDELLE	FINISH:MTD STD 701-01000
16	736-3084	1	RONDELLE	FINISH:MTD STD 701-01001
18	738-0372B	2	RONDELLE EPAULEE	FINISH:GEÖLT
19	738-04161	1	ARBRE DE DIRECTION .625 X 24.8	FINISH:SIEHE ZG.
20	741-0475	2	DOUILLE PLASTIQUE:.385 ID	NATUR ODER SCHWARZ 941-0475
21	741-0656	1	BAGUE	

www.emc-photoculture.com

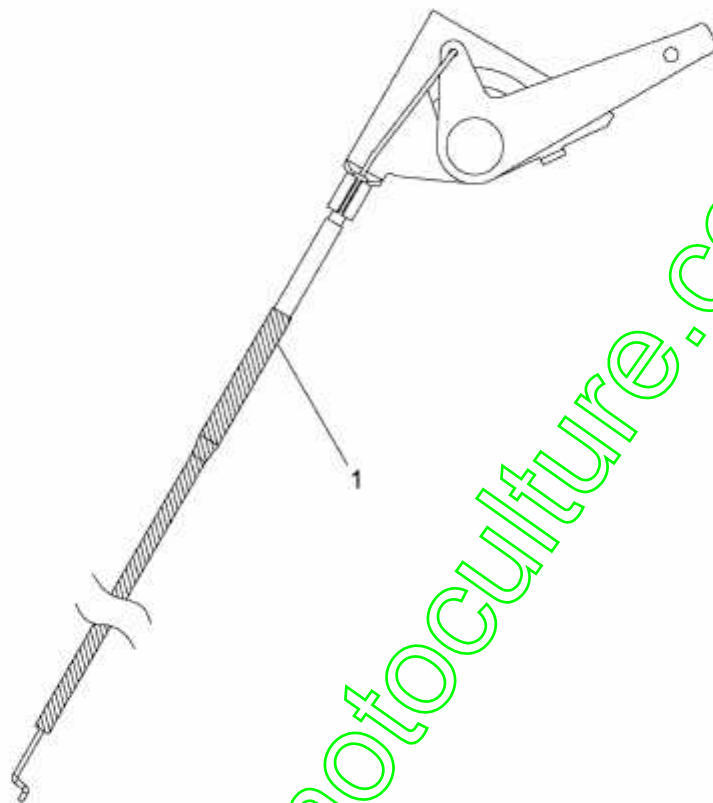

www.emc-motoculture.com

E3-03440A-01

Position	Numéro de lapièce	#	Appellation I	Appellation II
1	746-1086	1	CABLE ACCELERATEUR	FINISH:

www.emc-motoculture.com