

ILLUSTRATED PARTS LIST

NT 534 WTR NT 534 WTR-Q

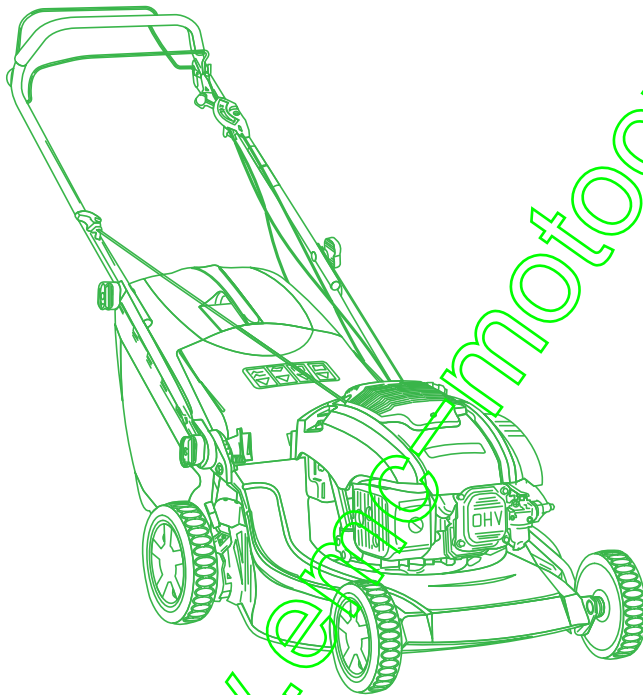

- Use GLOBAL GARDEN PRODUCT Genuine Spare Parts specified in the parts list for repair and/or replacement.
- The contents described in the parts list may change due to improvement.
- The drawings of the spare parts are only indicative and might not represent the part in question exactly.
- The indications "right" - "left" - "front" - "rear" refer to the position of the operator when using the machine.
- When placing orders of parts for repair and/or replacement, make sure that the illustrated parts list is the one applying to the machine's year of manufacture, as shown on the identification plate attached to the machine.

© Copyright 2014 Global Garden Products

All content is subject to copyright by Global Garden Products and may not be reproduced in whole or in part by any means, electronic or otherwise, without prior written approval.

THIS INFORMATION IS NOT INTENDED FOR SALE OR RESALE, AND THIS NOTICE MUST REMAIN ON ALL COPIES.



GLOBAL GARDEN PRODUCTS

www.ebay.com/motoculture.com

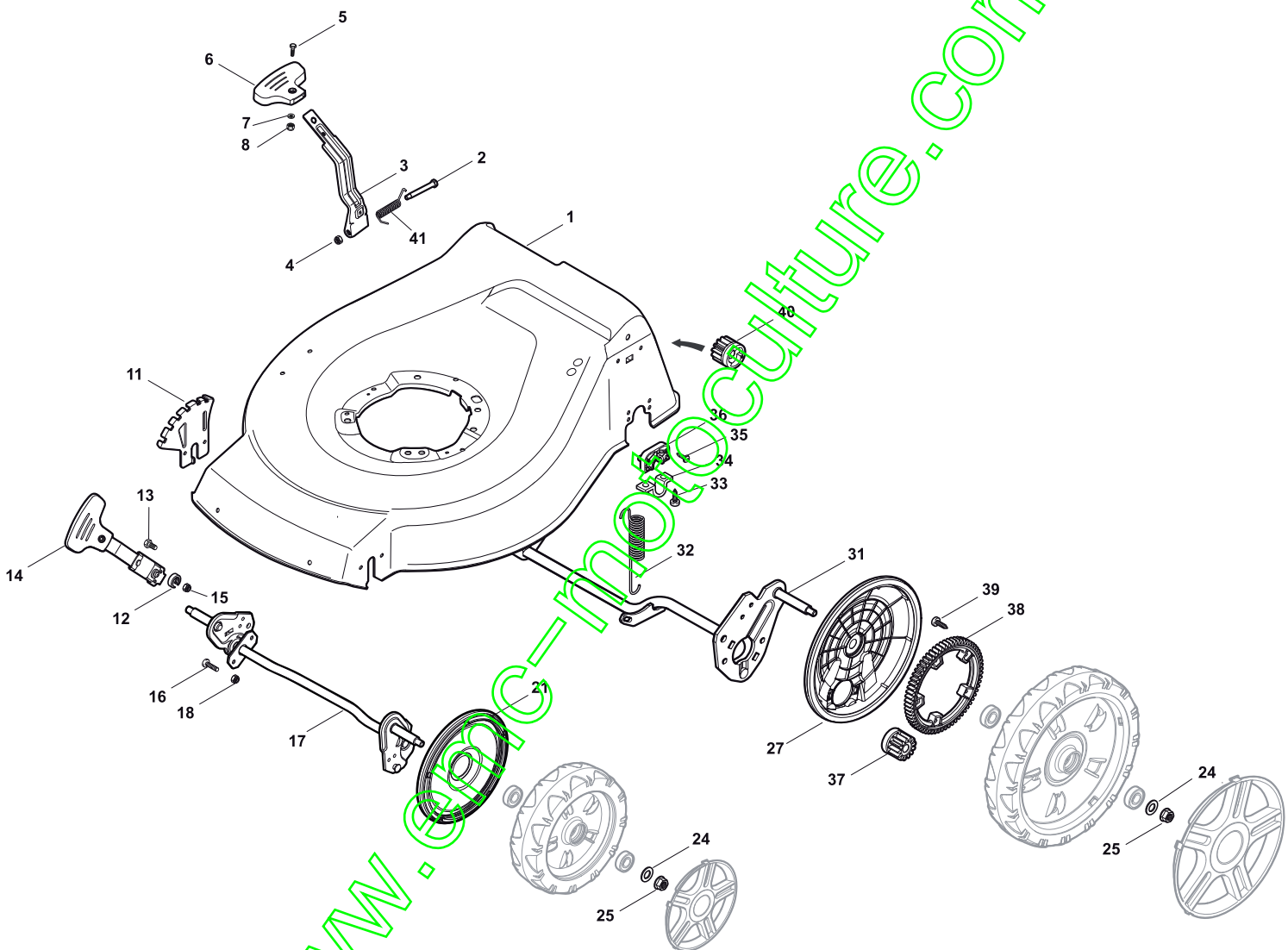

Deck And Height Adjusting

POS	PART. NO	Q.ty	DESCRIPTION	DESCRIZIONE	DESCRIPTION	BESCHREIBUNG	REMARKS
1	381004540/0	1	Deck Red	Chassis Rosso	Châssis Rouge	Gehäuse Rot	
1	381004542/0	1	Deck Red	Chassis Rosso	Châssis Rouge	Gehäuse Rot	Side Discharge
1	381004590/0	1	Deck Yellow	Chassis Giallo	Châssis Jaune	Gehäuse Gelb	
1	381004732/0	1	Deck Grey	Chassis Grigio	Châssis Gris	Gehäuse Grau	Side Discharge
2	122534131/0	1	Pin	Perno	Pivot	Bolzen	
3	381003398/0	1	Lever, Height Adjustment	Leva Regolazione Altezza	Levier Reglage Hauteur	Hebel, Höneverstellung	
4	112154510/0	1	Nut	Dado	Ecrou	Mutter	
5	112788512/0	1	Screw	Vite	Vis	Schraube	
6	322394503/0	1	Knob	Manopolina	Poignée	Griff	
7	112521310/0	1	Washer	Rosetta	Rondelle	Scheibe	
8	112150000/0	1	Nut	Dado	Ecrou	Mutter	
9	112728450/0	1	Screw	Vite	Vis	Schraube	
10	322034002/0	1	Washing Connection	Attacco Acqua Lavaggio	Attaque Lavage	Wascher-Verbindung	
11	322735589/0	1	Sector, Height Adjustment	Settore Regolazione Altezza	Secteur Reglage Hauteur	Sektor, Höneverstellung	
12	122171002/0	2	Spacer	Distanziale	Entretoise	Distanzring	
13	112789000/0	2	Screw	Vite	Vis	Schraube	
14	381003351/0	1	Lever, Height Adjustment	Leva Regolazione Altezza	Levier Reglage Hauteur	Hebel, Höneverstellung	
15	112154330/0	2	Nut	Dado	Ecrou	Mutter	
16	112727803/0	4	Screw	Vite	Vis	Schraube	
17	381002885/1	1	Axle, Front Wheels	Asse Ruote Anteriori	Axe Roues Avant	Achse, Vorderrad	
18	112154510/0	4	Nut	Dado	Ecrou	Mutter	
21	322600145/0	2	Protection, Wheel	Protezione Ruote	Protection Roue	Schütz, Räder	
24	112521350/0	4	Washer	Rosetta	Rondelle	Scheibe	
25	112155000/0	4	Nut	Dado	Ecrou	Mutter	
27	322600208/0	2	Protection, Wheel	Protezione Ruote	Protection Roue	Schütz, Räder	
31	381302835/1	1	Axle, Rear Wheels	Asse Ruote Posteriore	Axe Roues Arriere	Achse, Hinterrad	
32	122450460/0	1	Spring	Molla	Ressort	Feder	
33	112728697/0	4	Screw	Vite	Vis	Schraube	
34	322545152/0	2	Plate	Piastrina	Plaquette	Plättchen	
35	112728697/0	4	Screw	Vite	Vis	Schraube	
36	322785304/1	2	Support	Supporto	Support	Halter	
37	122570134/0	1	Pinion L	Pignone Sx	Pignon G	Ritzel Linkes	
38	322120115/0	2	Ring Gear	Corona	Couronne	Kranz	
39	112728706/0	6	Screw	Vite	Vis	Schraube	
40	122570133/0	1	Pinion R	Pignone Dx	Pignon D	Ritzel Rechtes	
41	122446192/0	1	Spring	Molla	Ressort	Feder	

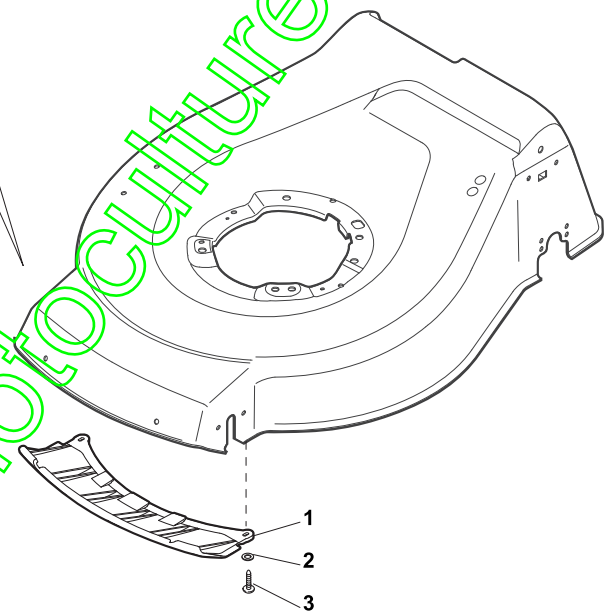
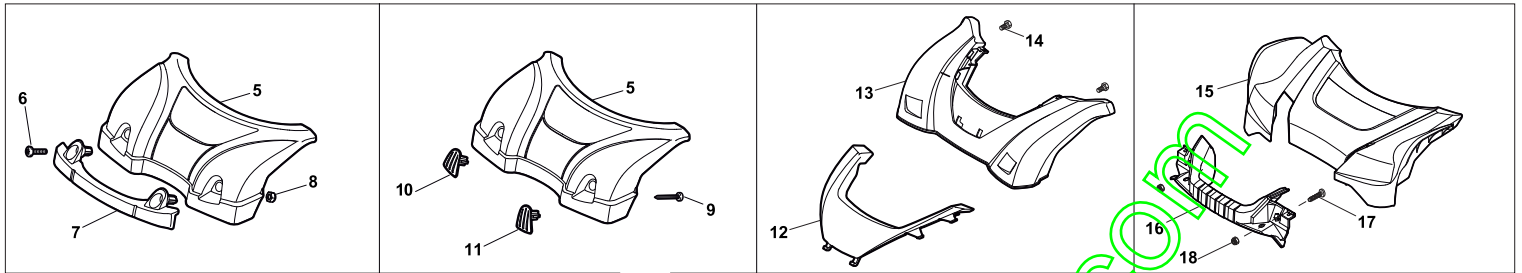

www.emc-motoculture.com

Mask							
POS	PART. NO	Q.ty	DESCRIPTION	DESCRIZIONE	DESCRIPTION	BESCHREIBUNG	REMARKS
1	322500103/0	1	Front Combi	Pettine Anteriore	Vorne Comb	Peigne Avant	
2	112523000/1	2	Washer	Rosetta	Rondelle	Scheibe	
3	112728124/0	2	Screw	Vite	Vis	Schraube	
5	322226145/0	1	Mask, Red	Mascherina, Rosso	Mesque, Rouge	Maske, Rot	
5	322226154/0	1	Mask, Black	Mascherina, Nero	Mesque, Noir	Maske, Schwarz	
6	112727799/0	2	Screw	Vite	Vis	Schraube	
7	322393638/0	1	Handle, Black	Maniglia, Nero	Poignee, Noir	Griff, Schwarz	
7	322393639/0	1	Handle, Grey	Maniglia Grigio	Poignee, Gris	Griff, Grau	
7	322393640/0	1	Handle, Yellow	Maniglia, Gialla	Poignee, Jaune	Griff, Gelb	
8	112154510/0	2	Nut	Dado	Ecrou	Mutter	
9	112728697/0	2	Screw	Vite	Vis	Schraube	
10	322820082/0	1	Cap	Puntale	Bouchon	Gummistopfen	
11	322820083/0	1	Cap	Puntale	Bouchon	Gummistopfen	
12	322226167/0	1	Frontal Plate	Piastra Frontale	Avant Plaquette	Front Plättchen	
13	322226166/0	1	Mask, Black	Mascherina, Nero	Mesque, Noir	Maske, Schwarz	
14	112728300/0	2	Screw	Vite	Vis	Schraube	
15	322226158/0	1	Mask, Black	Mascherina, Nero	Mesque, Noir	Maske, Schwarz	
16	322393642/0	1	Bumper	Bumper	Bumper	Bumper	
17	112727799/0	2	Screw	Vite	Vis	Schraube	
18	112154510/0	2	Nut	Dado	Ecrou	Mutter	

www.emc-motoculture.com

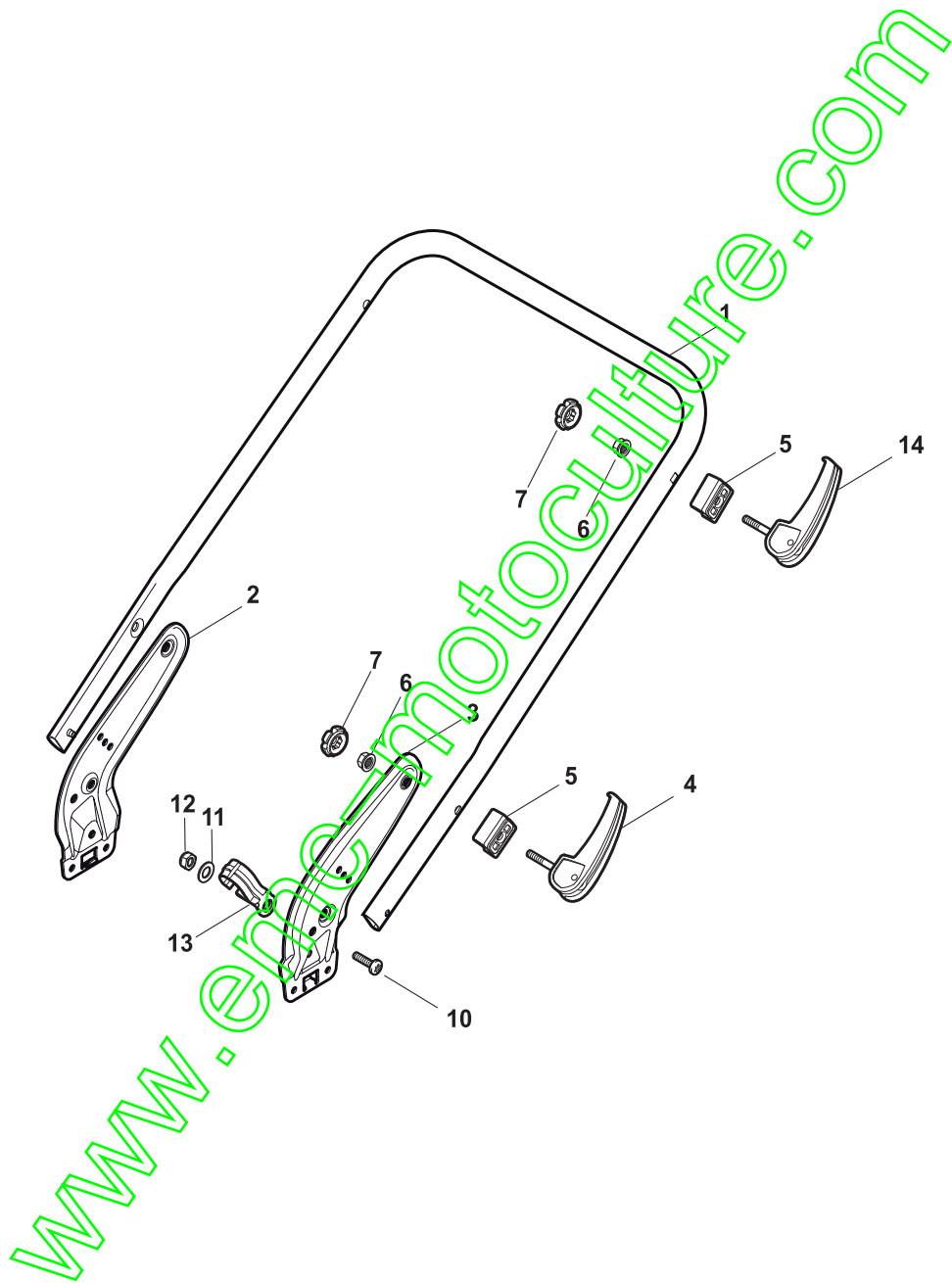

Handle, Lower Part (LUX Version)

POS	PART. NO	Q.ty	DESCRIPTION	DESCRIZIONE	DESCRIPTION	BESCHREIBUNG	REMARKS
1	381006719/0	1	Handle, Lower Part	Parte Inf Maniglia	Poignée, Partie Inferieure	Griff, Unterteil	Black
1	381006720/0	1	Handle, Lower Part	Parte Inf Maniglia	Poignée, Partie Inferieure	Griff, Unterteil	Grey
1	381007539/0	1	Handle, Lower Part	Parte Inf Maniglia	Poignée, Partie Inferieure	Griff, Unterteil	Yellow
2	381005149/0	1	Bracket, R	Staffa Dx	Etrier Droit	Steigbügel, Rechte	
3	381005151/0	1	Bracket, L	Staffa Sx	Etrier Gauche	Steigbügel, Linke	
4	381003253/0	2	Handle	Maniglia	Poignée	Griff	
5	322680016/0	4	Support	Supporto	Support	Halter	
6	122131750/0	4	Nut	Dado	Ecrou	Mutter	
7	322399835/0	4	Knob	Manopolina	Poignée	Griff	
10	112760605/0	2	Screw	Vite	Vis	Schraube	
11	125038002/1	2	Bush	Bussola	Douille	Büchse	
12	112155000/0	2	Nut	Dado	Ecrou	Mutter	
13	322192156/0	1	Fair Led	Fascetta	Collier	Bowdenzughalter	
14	381103350/0	2	Handle	Maniglia	Poignée	Griff	

www.emc-motoculture.com

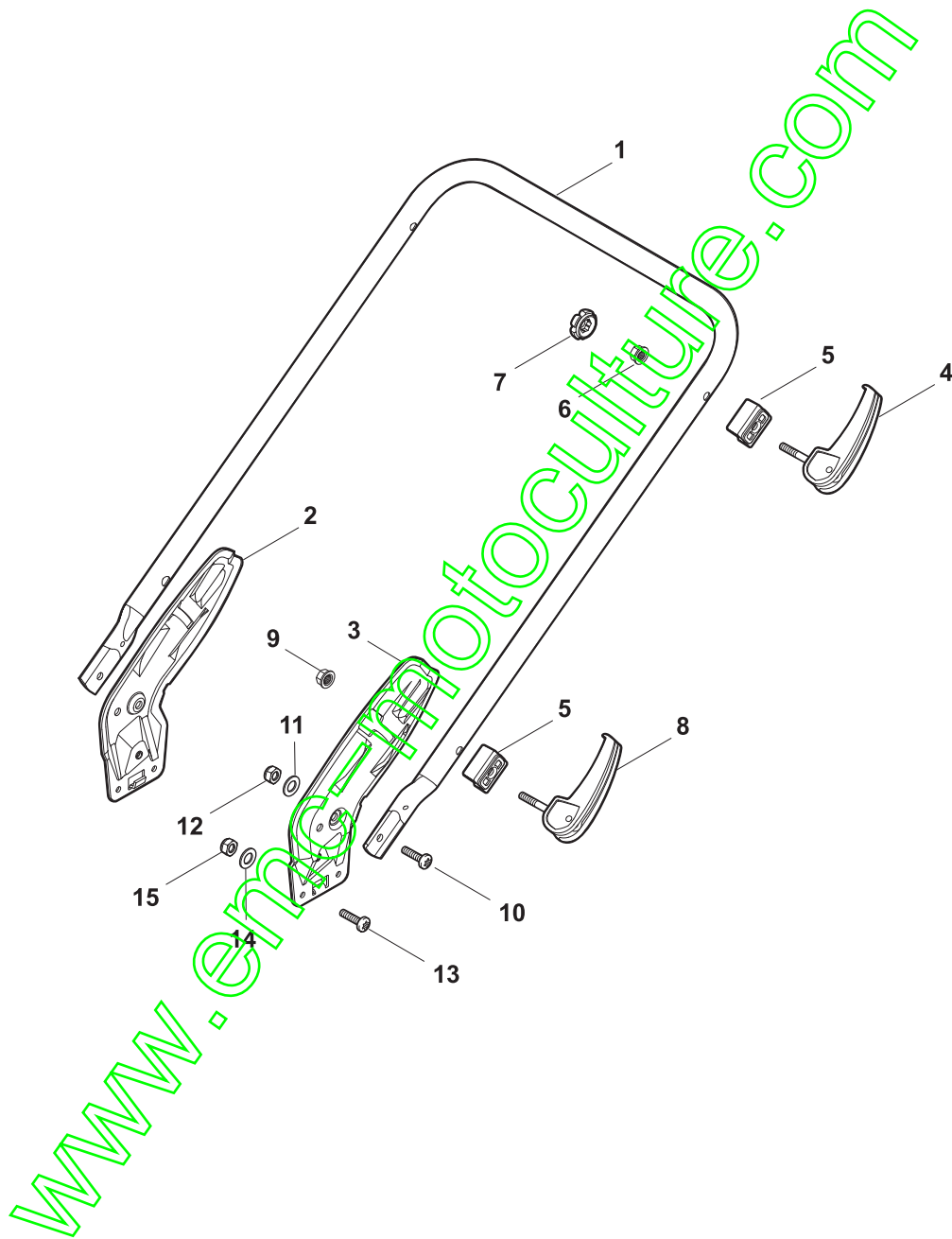

Handle, Lower Part

POS	PART. NO	Q.ty	DESCRIPTION	DESCRIZIONE	DESCRIPTION	BESCHREIBUNG	REMARKS
1	381006891/0	1	Handle, Lower Part	Manico, Parte Inferiore	Mancheron, Partie Inferieure	Holm, Unterteil	
2	381005125/0	1	Bracket, R	Staffa Dx	Etrier Droit	Steigbügel, Rechte	
3	381005127/0	1	Bracket, L	Staffa Sx	Etrier Gauche	Steigbügel, Linke	
4	381103350/0	2	Handle	Maniglia	Poignée	Griff	
5	322680016/0	4	Support	Supporto	Support	Halter	
6	122131750/0	2	Nut	Dado	Ecrou	Mutter	
7	322399835/0	2	Knob	Manopolina	Poignée	Griff	
8	381003254/0	2	Handle	Maniglia	Poignée	Griff	
9	112154220/0	2	Nut	Dado	Ecrou	Mutter	
10	112760605/0	2	Screw	Vite	Vis	Schraube	
11	112521350/0	2	Washer	Rosetta	Rondelle	Scheibe	
12	112155000/0	2	Nut	Dado	Ecrou	Mutter	
13	112727803/0	6	Screw	Vite	Vis	Schraube	
14	112523040/0	6	Washer	Rosetta	Rondelle	Scheibe	
15	112154510/0	6	Nut	Dado	Ecrou	Mutter	

www.emc-motoculture.com

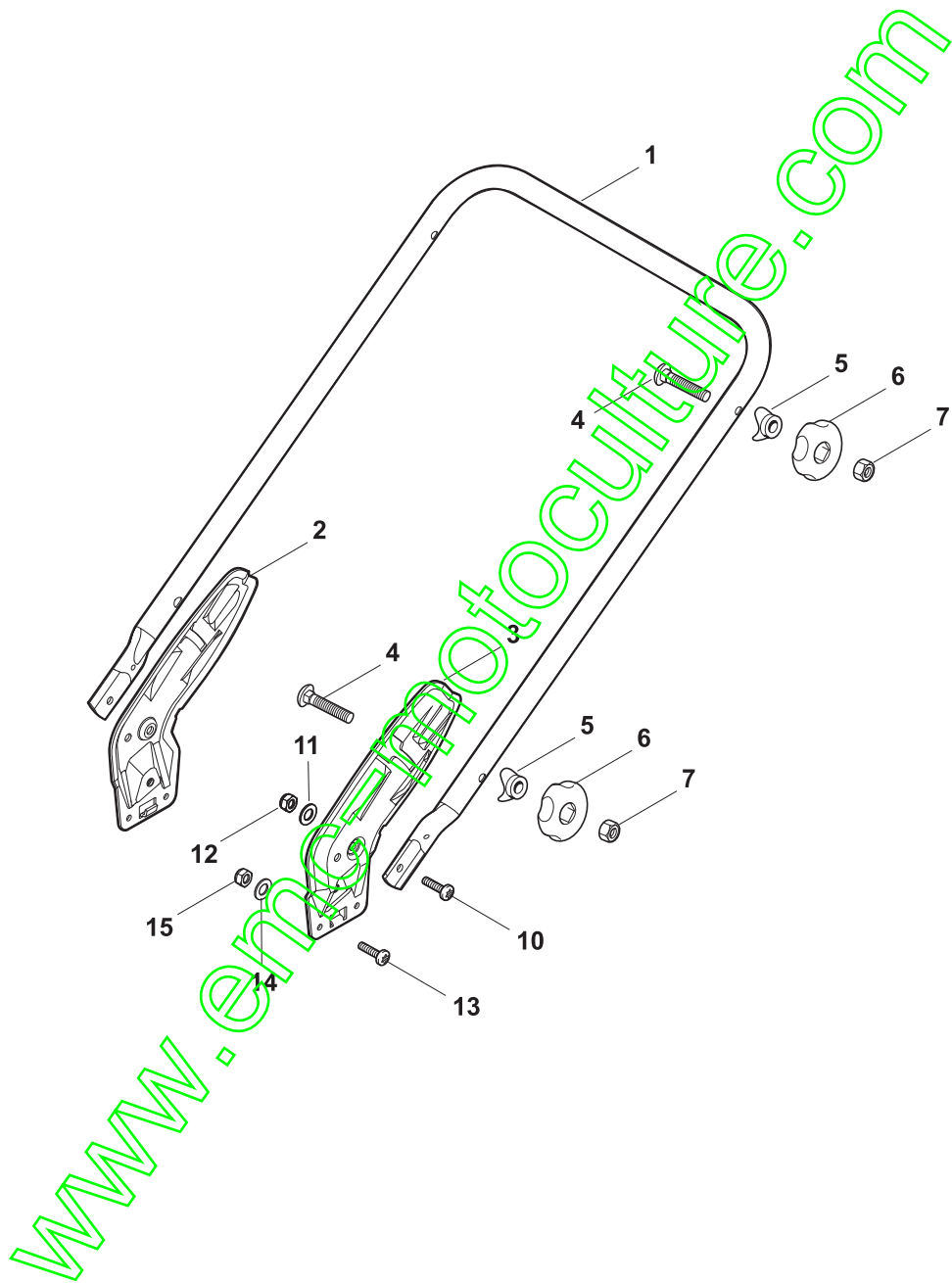

Handle, Lower Part

POS	PART. NO	Q.ty	DESCRIPTION	DESCRIZIONE	DESCRIPTION	BESCHREIBUNG	REMARKS
1	381006891/0	1	Handle, Lower Part	Parte Inf Maniglia	Poignée, Partie Inferieure	Griff, Unterteil	
2	381005125/0	1	Bracket, R	Staffa Dx	Etrier Droit	Steigbügel, Rechte	
3	381005127/0	1	Bracket, L	Staffa Sx	Etrier Gauche	Steigbügel, Linke	
4	112819120/0	4	Screw	Vite	Vis	Schraube	
5	122680006/1	4	Washer	Rosetta	Rondelle	Scheibe	
6	322399804/1	4	Knob	Manopolina	Poignée	Griff	
7	112293200/0	4	Nut	Dado	Ecrou	Mutter	
10	112760605/0	2	Screw	Vite	Vis	Schraube	
11	112521350/0	2	Washer	Rosetta	Rondelle	Scheibe	
12	112155000/0	2	Nut	Dado	Ecrou	Mutter	
13	112727803/0	6	Screw	Vite	Vis	Schraube	
14	112523040/0	6	Washer	Rosetta	Rondelle	Scheibe	
15	112154510/0	6	Nut	Dado	Ecrou	Mutter	

www.emc-motoculture.com

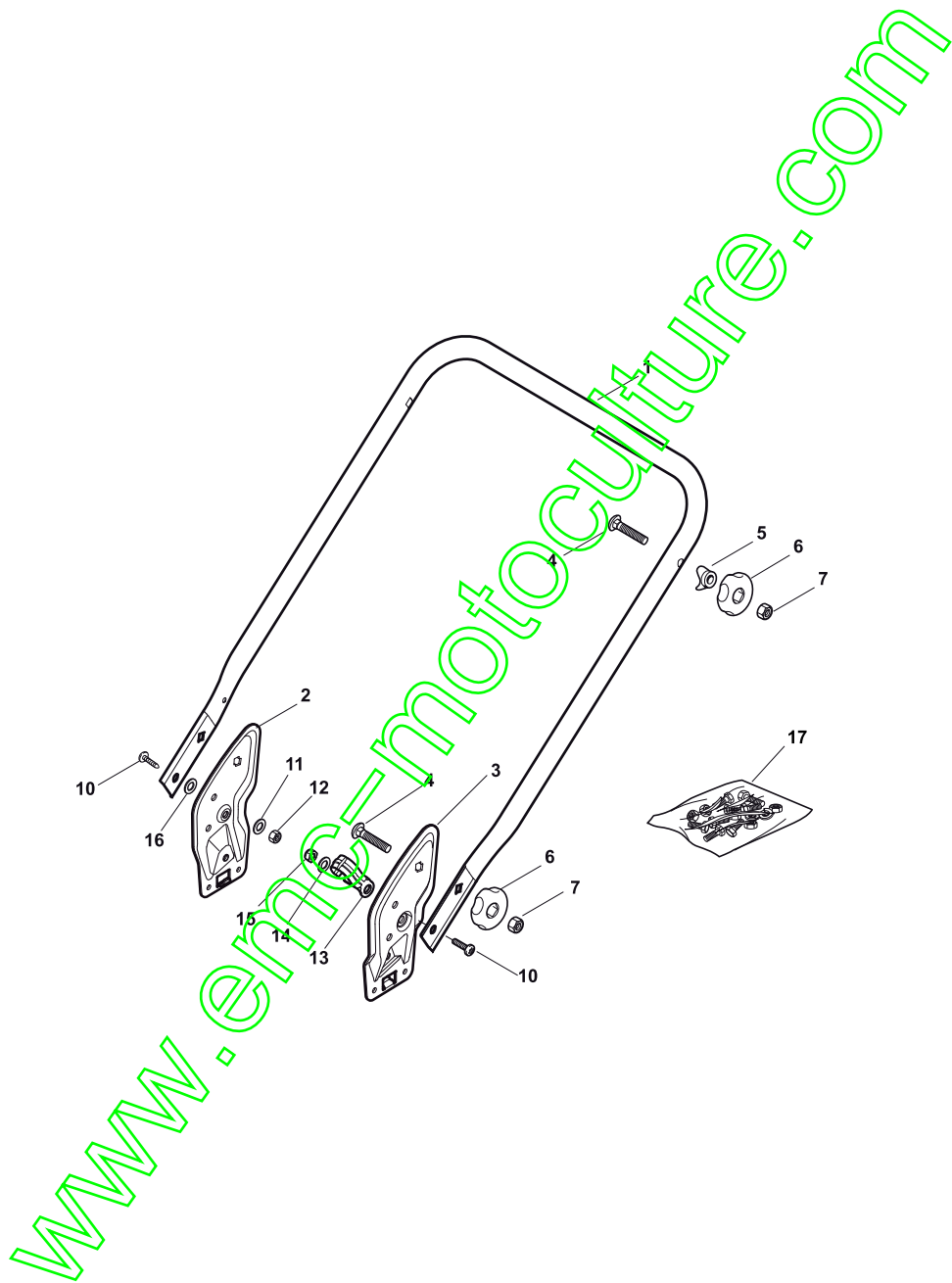

Handle, Lower Part (ERGO Version)

POS	PART. NO	Q.ty	DESCRIPTION	DESCRIZIONE	DESCRIPTION	BESCHREIBUNG	REMARKS
1	381007043/0	1	Handle, Lower Part	Parte Inf Maniglia	Poignée, Partie Inferieure	Griff, Unterteil	
2	381005133/0	1	Bracket, R	Staffa Dx	Etrier Droit	Steigbügel, Rechte	
3	381005135/0	1	Bracket, L	Staffa Sx	Etrier Gauche	Steigbügel, Linke	
4	112819120/0	1	Screw	Vite	Vis	Schraube	
5	122680006/1	4	Washer	Rosetta	Rondelle	Scheibe	
6	322399804/1	4	Knob	Manopolina	Poignée	Griff	
7	112293200/0	4	Nut	Dado	Ecrou	Mutter	
10	112760605/0	4	Screw	Vite	Vis	Schraube	
11	125038002/1	1	Bush	Bussola	Douille	Büchse	
12	112155000/0	2	Nut	Dado	Ecrou	Mutter	
13	322192156/0	2	Fair Led	Fascetta	Collier	Bowdenzughalter	
14	112523040/0	1	Washer	Rosetta	Rondelle	Scheibe	
15	112154510/0	1	Nut	Dado	Ecrou	Mutter	
16	112369500/0	1	Elastic Washer	Disco Elastico	Disque Elastique	Federscheibe	
17	381008686/0	2	Outfit, Screws	Dotazione Viteria	Dotation Visserie	Satz Schrauben	

www.emc-motoculture.com

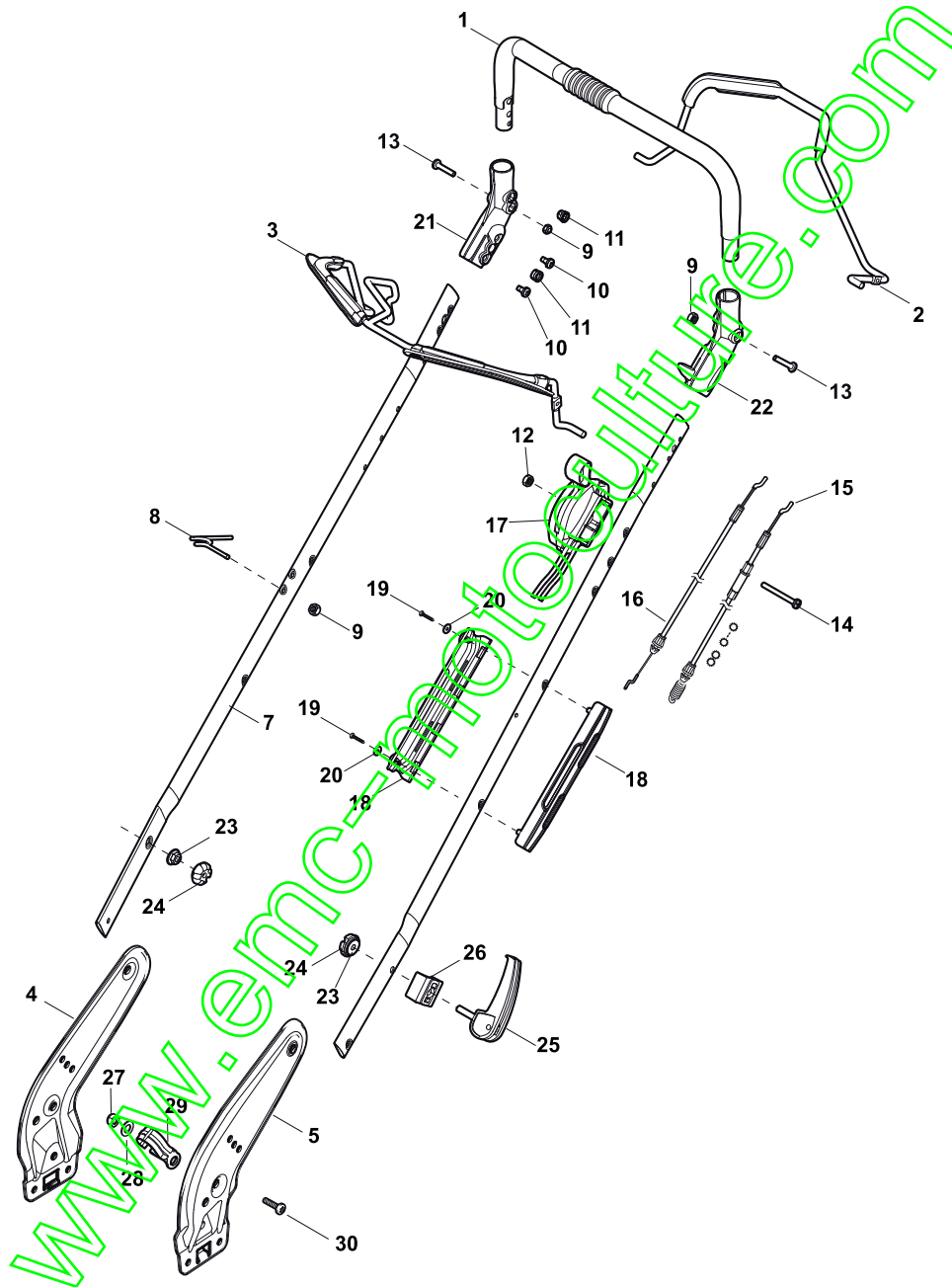

Handle, Upper Part

POS	PART. NO	Q.ty	DESCRIPTION	DESCRIZIONE	DESCRIPTION	BESCHREIBUNG	REMARKS
1	381006670/2	1	Handgrip	Impugnatura	Poignée	Handgriff	
2	381003349/0	1	Lever, Driving	Leva Trazione	Levier Traction	Antriebhebel	
3	381003344/0	1	Lever, Engine Brake	Leva Freno Motore	Levier Frein Moteur	Hebel, Motorbremse	
4	381005149/0	1	Bracket, R	Staffa Dx	Etrier Droit	Steigbügel, Rechte	
5	381005151/0	1	Bracket, L	Staffa Sx	Etrier Gauche	Steigbügel, Linke	
7	381006773/1	2	Handle Black	Manico Nero	Mancheron Noir	Holm Schwarz	Black
7	381006774/1	2	Handle Grey	Manico Grigio	Mancheron Gris	Holm Grau	Grey
8	122430309/0	1	Spring	Molla	Ressort	Feder	
9	112154330/0	2	Nut	Dado	Ecrou	Mutter	
10	112735662/1	4	Screw	Vite	Vis	Schraube	
11	322041967/0	4	Bush	Bussola	Douille	Büchse	
12	112154510/0	3	Nut	Dado	Ecrou	Mutter	
13	112728721/0	2	Screw	Vite	Vis	Schraube	
14	112727786/0	1	Screw	Vite	Vis	Schraube	
15	381030093/1	1	Cable, Rear Drive	Cavo Comando Trazione	Câble, Comm. Traction	Kabel, Antrieb	
16	181030074/0	1	Cable, Thread Engine Brake	Cavo Freno Motore	Cable Frein Moteur	Kabel, Motorbremse	
17	181005512/0	1	Throttle Cable	Cavo Acceleratore	Cable, Accelérateur	Gashebel Kabel	for Honda-GGP Engine
17	181005513/0	1	Throttle Cable	Cavo Acceleratore	Cable, Accelérateur	Gashebel Kabel	for Honda AC Engine
17	181005502/1	1	Throttle Cable	Cavo Acceleratore	Cable, Accelérateur	Gashebel Kabel	for B&S 625-675 Series
17	181005525/0	1	Throttle Cable	Cavo Acceleratore	Cable, Accelérateur	Gashebel Kabel	for B&S 500-550-575 Series
17	181005523/1	1	Throttle Cable	Cavo Acceleratore	Cable, Accelérateur	Gashebel Kabel	B&S DOV
18	322806644/0	1	Protection	Cappuccio	Capuchon	Stecker	
19	112727812/0	2	Screw	Vite	Vis	Schraube	
20	112523000/1	2	Washer	Rosetta	Rondelle	Scheibe	
21	322488301/0	1	Support, R	Supporto, Parte Dx	Support, D	Halter, Rechte	
22	322488303/0	1	Support, L	Supporto, Parte Sx	Support, G	Halter, Linke	
23	112154220/0	2	Nut	Dado	Ecrou	Mutter	
24	322399835/0	2	Knob	Manopolina	Poignée	Griff	
25	381003253/0	2	Handle	Maniglia	Poignée	Griff	
26	322680017/0	2	Support	Supporto	Support	Halter	
27	112155000/0	1	Nut	Dado	Ecrou	Mutter	
28	125038002/1	1	Bush	Bussola	Douille	Büchse	
29	322192156/0	1	Fair Led	Fascetta	Collier	Bowdenzughalter	
30	112760605/0	1	Screw	Vite	Vis	Schraube	

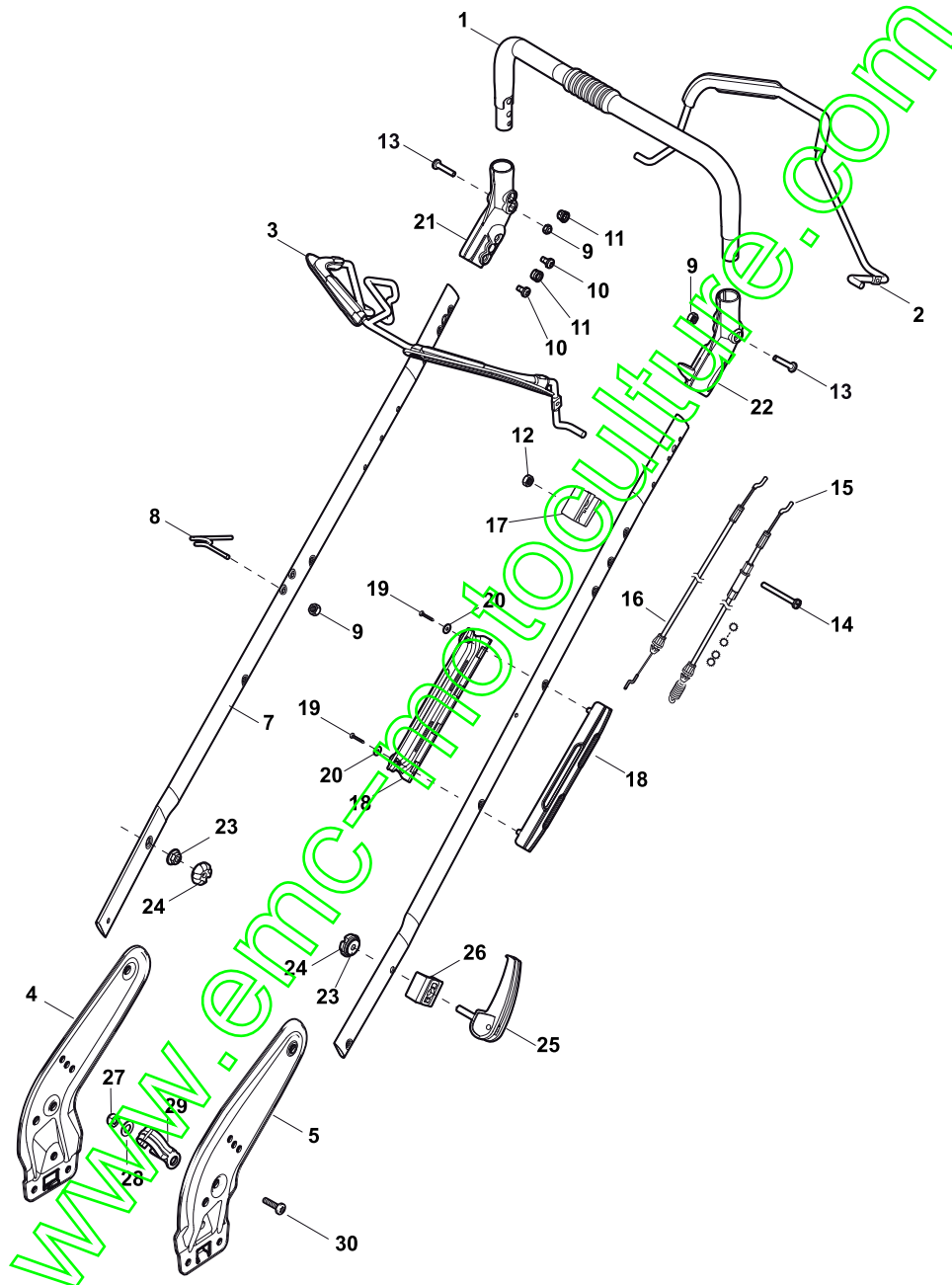

Handle, Upper Part

POS	PART. NO	Q.ty	DESCRIPTION	DESCRIZIONE	DESCRIPTION	BESCHREIBUNG	REMARKS
1	381006670/2	1	Handgrip	Impugnatura	Poignée	Handgriff	
2	381003349/0	1	Lever, Driving	Leva Trazione	Levier Traction	Antriebhebel	
3	381003344/0	1	Lever, Engine Brake	Leva Freno Motore	Levier Frein Moteur	Hebel, Motorbremse	
4	381005149/0	1	Bracket, R	Staffa Dx	Etrier Droit	Steigbügel, Rechte	
5	381005151/0	1	Bracket, L	Staffa Sx	Etrier Gauche	Steigbügel, Linke	
7	381006773/1	2	Handle Black	Manico Nero	Mancheron Noir	Holm Schwarz	Black
7	381006774/1	2	Handle Grey	Manico Grigio	Mancheron Gris	Holm Grau	Grey
8	122430309/0	1	Spring	Molla	Ressort	Feder	
9	112154330/0	2	Nut	Dado	Ecrou	Mutter	
10	112735662/1	4	Screw	Vite	Vis	Schraube	
11	322041967/0	4	Bush	Bussola	Douille	Büchse	
12	112154510/0	3	Nut	Dado	Ecrou	Mutter	
13	112728721/0	2	Screw	Vite	Vis	Schraube	
14	112727784/0	1	Screw	Vite	Vis	Schraube	
14	112727786/0	1	Screw	Vite	Vis	Schraube	
15	381030097/0	1	Cable, Rear Drive	Cavo Comando Trazione	Câble, Comm. Traction	Kabel, Antrieb	
16	181030100/0	1	Cable, Thread Engine Brake	Cavo Freno Motore	Cable Frein Moteur	Kabel, Motorbremse	
17	322551639/0	1	Plate	Piastrina	Plaquette	Plättchen	
18	322806644/0	1	Protection	Cappuccio	Capuchon	Stecker	
19	112727812/0	2	Screw	Vite	Vis	Schraube	
20	112523000/1	2	Washer	Rosetta	Rondelle	Scheibe	
21	322488301/0	1	Support , R	Supporto, Parte Dx	Support, D	Halter, Rechte	
22	322488303/0	1	Support, L	Supporto, Parte Sx	Support, G	Halter, Linke	
23	112154220/0	2	Nut	Dado	Ecrou	Mutter	
24	322399835/0	2	Knob	Manopolina	Poignée	Griff	
25	381003253/0	2	Handle	Maniglia	Poignée	Griff	
26	322680017/0	2	Support	Supporto	Support	Halter	
27	112155000/0	1	Nut	Dado	Ecrou	Mutter	
28	125038002/1	1	Bush	Bussola	Douille	Büchse	
29	322192156/0	1	Fair Led	Fascetta	Collier	Bowdenzughalter	
30	112760605/0	1	Screw	Vite	Vis	Schraube	

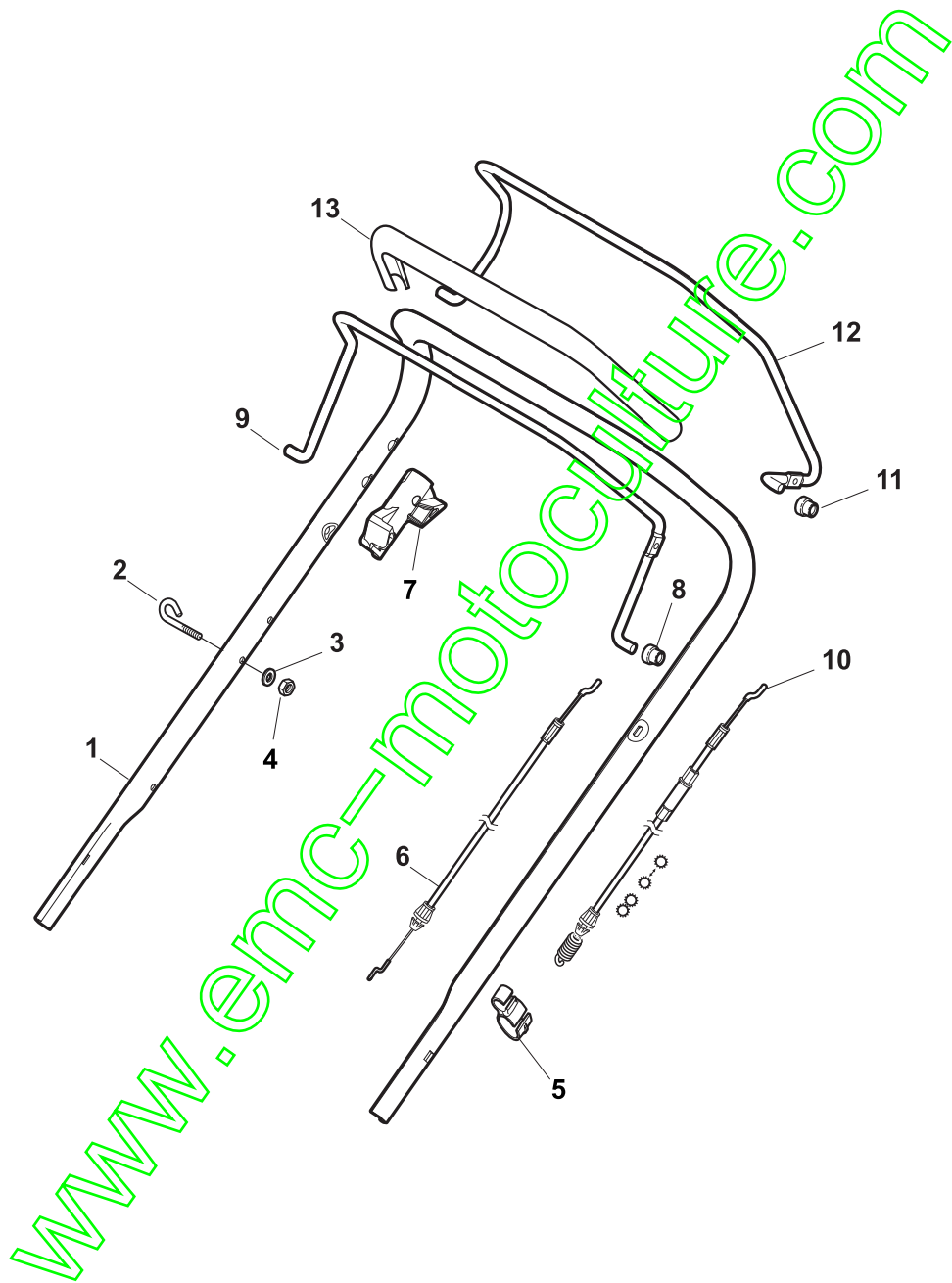

Handle, Upper Part (LUX Version)							
POS	PART. NO	Q.ty	DESCRIPTION	DESCRIZIONE	DESCRIPTION	BESCHREIBUNG	REMARKS
1	381006838/0	1	Handle, Upper Part	Manico, Parte Sup	Mancheron, Partie Superieure	Holm, Oberteil	for NT Throttle/DELTA Dashboard
1	381007522/0	1	Handle, Upper Part	Manico, Parte Sup	Mancheron, Partie Superieure	Holm, Oberteil	for TD-CA Dashboard (Black)
1	381007525/0	1	Handle, Upper Part	Manico, Parte Sup	Mancheron, Partie Superieure	Holm, Oberteil	for TD-CA Dashboard (Grey)
2	122430313/0	1	Guide Spring	Molla Guida	Ressort De Guide	Feder Führer	
3	112521330/0	1	Washer	Rosetta	Rondelle	Scheibe	
4	112154510/0	1	Nut	Dado	Ecrou	Mutter	
5	118390020/0	1	Fairlead	Fermacavo	Fixation Cable	Kabelbefestigung	
6	181030053/0	1	Cable, Thread Engine Brake	Cavo Freno Motore	Cable Frein Moteur	Kabel, Motorbremse	GGP-B&S Engine
6	181030054/0	1	Cable, Thread Engine Brake	Cavo Freno Motore	Cable Frein Moteur	Kabel, Motorbremse	M150-V35-SV40 Engine
6	181030070/0	1	Cable, Thread Engine Brake	Cavo Freno Motore	Cable Frein Moteur	Kabel, Motorbremse	for Honda Engine
7	322545204/0	1	Fulcrum Pin	Perno Fulcro	Pivot	Gelenkpunkt	
8	122041966/0	1	Bush	Bussola	Douille	Büchse	
9	181003300/1	1	Lever, Engine Brake	Leva Freno Motore	Levier Frein Moteur	Kabel, Motorbremse	
10	381030092/0	1	Cable, Rear Drive	Cavo Comando Trazione	Câble, Comm. Traction	Kabel, Antrieb	
11	122041966/0	1	Bush	Bussola	Douille	Büchse	
12	181003301/0	1	Lever, Driving	Leva Trazione	Levier Traction	Antriebhebel	
13	122291050/0	1	Handgrip Black	Impugnatura Manico Nera	Poignée Noir	Handgriff Schwarz	

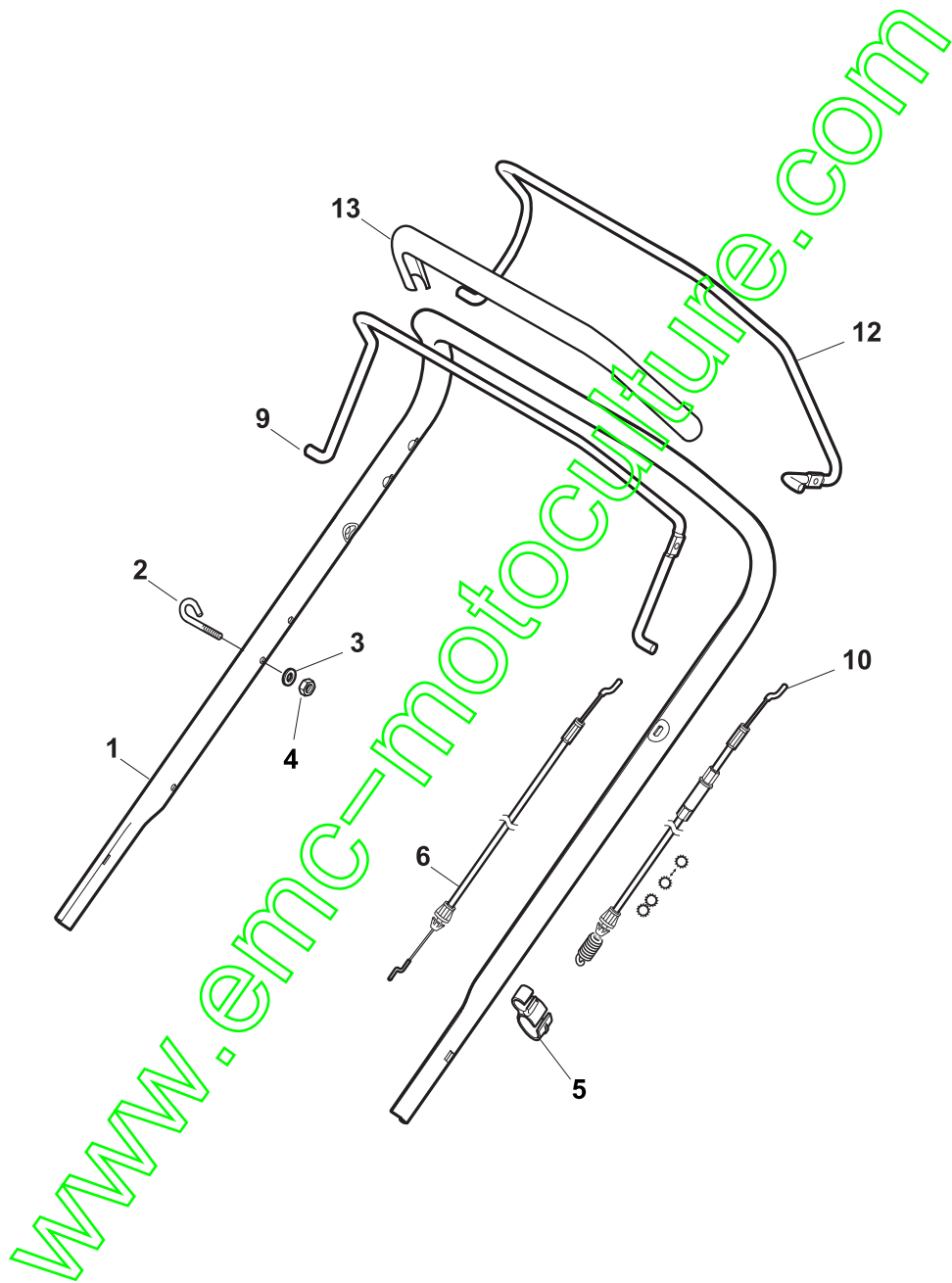

Handle, Upper Part (ERGO Version)							
POS	PART. NO	Q.ty	DESCRIPTION	DESCRIZIONE	DESCRIPTION	BESCHREIBUNG	REMARKS
1	381007520/0	1	Handle, Upper Part	Manico, Parte Sup	Mancheron, Partie Superieure	Holm, Oberteil	TD-CA Dashboard/ RPM Fix
1	381006840/0	1	Handle, Upper Part	Manico, Parte Sup	Mancheron, Partie Superieure	Holm, Oberteil	DELTA Dashboard / Throttle
2	122430313/0	1	Guide Spring	Molla Guida	Ressort De Guide	Feder Führer	
3	112521330/0	1	Washer	Rosetta	Rondelle	Scheibe	
4	112154510/0	1	Nut	Dado	Ecrou	Mutter	
5	118390020/0	1	Fairlead	Fermacavo	Fixation Cable	Kabelbefestigung	
6	181030053/0	1	Cable, Thread Engine Brake	Cavo Freno Motore	Cable Frein Moteur	Kabel, Motorbremse	GGP-B&S Engine
6	181030054/0	1	Cable, Thread Engine Brake	Cavo Freno Motore	Cable Frein Moteur	Kabel, Motorbremse	M150-V35-SV40 Engine
6	181030070/0	1	Cable, Thread Engine Brake	Cavo Freno Motore	Cable Frein Moteur	Kabel, Motorbremse	for Honda Engine
9	181003363/1	1	Lever, Engine Brake Black	Leva Freno Motore Nero	Levier Frein Moteur Noir	Hebel, Motorbremse Schwarz	
10	381030051/0	1	Cable, Rear Drive	Cavo Comando Trazione	Câble, Comm. Traction	Kabel, Antrieb	
12	181003364/0	1	Lever, Driving Black	Leva Trazione Nero	Levier Traction Noir	Hebel, Antrieb Schwarz	
13	122291050/0	1	Handgrip Black	Impugnatura Manico Nera	Poignée Noir	Handgriff Schwarz	

www.emc-motoculture.com

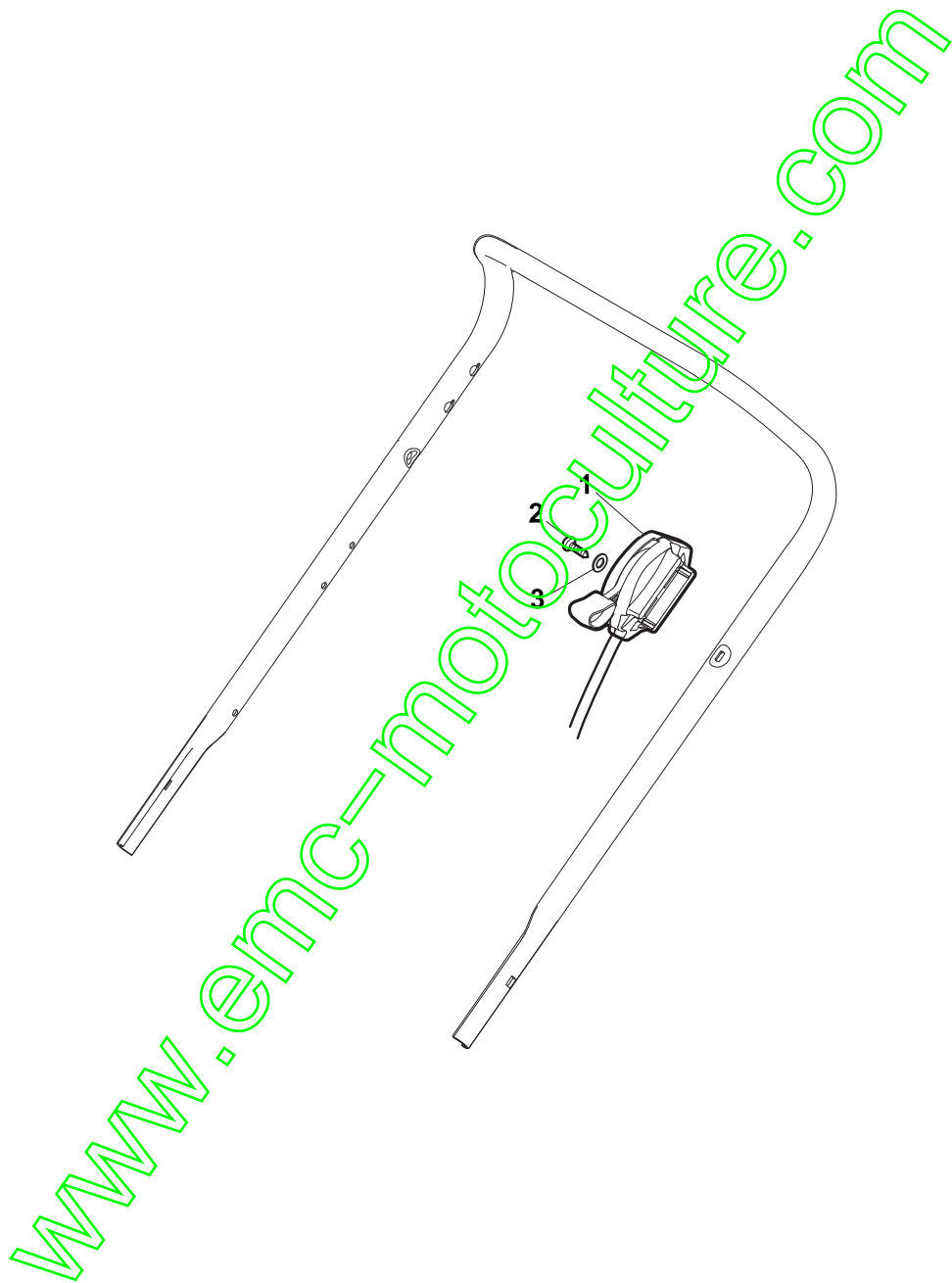

Throttle							
POS	PART. NO	Q.ty	DESCRIPTION	DESCRIZIONE	DESCRIPTION	BESCHREIBUNG	REMARKS
1	181005501/1	1	Throttle Cable	Cavo Acceleratore	Cable, Accelérateur	Gashebel Kabel	GGP Engine
1	181005501/1	1	Throttle Cable	Cavo Acceleratore	Cable, Accelérateur	Gashebel Kabel	Honda Engine
1	181005502/1	1	Throttle Cable	Cavo Acceleratore	Cable, Accelérateur	Gashebel Kabel	B&S 450-625-650-675 Series
1	181005503/1	1	Throttle Cable	Cavo Acceleratore	Cable, Accelérateur	Gashebel Kabel	Honda AC Engine
1	181005504/1	1	Throttle Cable	Cavo Acceleratore	Cable, Accelérateur	Gashebel Kabel	GGP 150cc
1	181005515/0	1	Throttle Cable	Cavo Acceleratore	Cable, Accelérateur	Gashebel Kabel	B&S 500-550-575 Series
1	181005520/1	1	Throttle Cable	Cavo Acceleratore	Cable, Accelérateur	Gashebel Kabel	B&S 750-700
1	181005523/1	1	Throttle Cable	Cavo Acceleratore	Cable, Accelérateur	Gashebel Kabel	B&S 850
1	181005537/0	1	Throttle Cable	Cavo Acceleratore	Cable, Accelérateur	Gashebel Kabel	GGP 100cc
2	112735103/0	1	Screw	Vite	Vis	Schraube	
3	112523040/0	1	Washer	Rosetta	Rondelle	Scheibe	

www.emc-motoculture.com

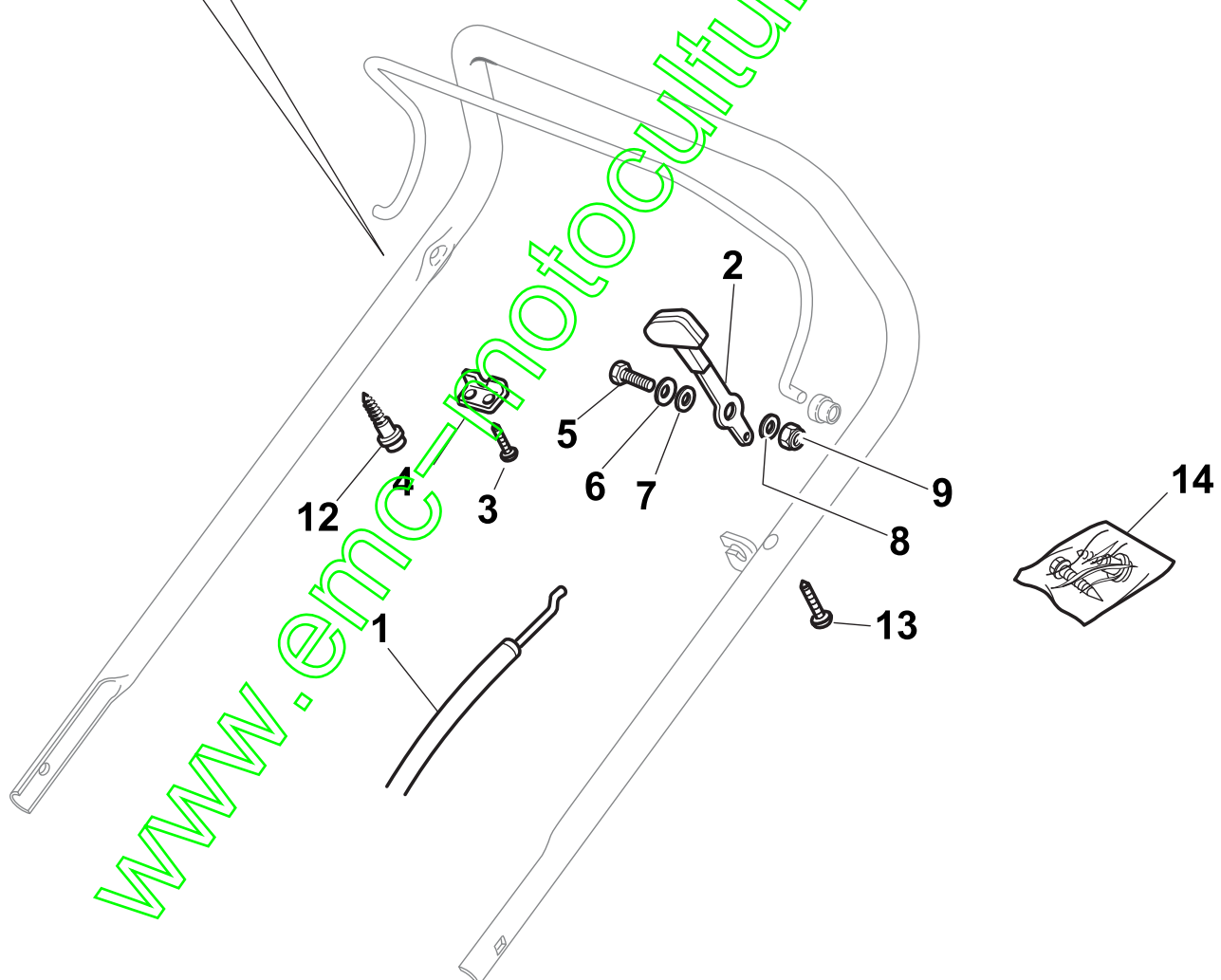
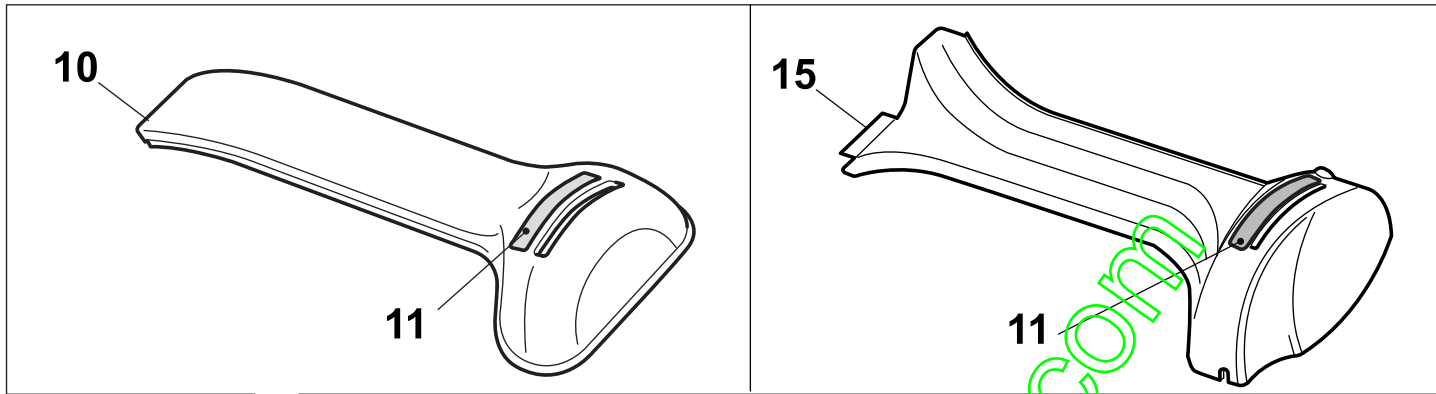

Dashboards

POS	PART. NO	Q.ty	DESCRIPTION	DESCRIZIONE	DESCRIPTION	BESCHREIBUNG	REMARKS
1	481007160/0	1	Throttle Cable	Cavo Acceleratore	Cable, Accelérateur	Gashebel Kabel	
2	381007280/2	1	Lever, Throttle	Leva, Acceleratore	Levier, Accelérateur	Hebel, Beschleuniger	for GGP-Honda-B&S Engine
3	112735105/0	2	Screw	Vite	Vis	Schraube	
4	322981467/0	1	Plate	Piastrina	Plaquette	Plättchen	
5	112791500/0	1	Screw	Vite	Vis	Schraube	
6	112530060/0	1	Elastic Washer	Disco Elastico	Disque Elastique	Federscheibe	
7	112523040/0	1	Washer	Rosetta	Rondelle	Scheibe	
8	112523040/0	1	Washer	Rosetta	Rondelle	Scheibe	
9	112154510/0	1	Nut	Dado	Ecrou	Mutter	
10	322120189/0	1	Dash Board Red	Cruscotto Rosso	Console Rouge	Konsole Rote	
11	114356743/1	1	Label	Etichetta	Etiquette	Etikette	for GGP - Honda Engine
11	114356744/1	1	Label	Etichetta	Etiquette	Etikette	for B&S Engine
11	114356906/1	1	Label	Etichetta	Etiquette	Etikette	for B&S DOV
11	114357646/1	1	Label	Etichetta	Etiquette	Etikette	for HONDA AC
12	122943006/0	1	Screw	Vite	Vis	Schraube	
13	112728460/0	1	Screw	Vite	Vis	Schraube	
14	381008609/0	1	Outfit, Screws	Dotazione Viteria	Dotation Visserie	Satz, Schrauben	
15	422120152/0	1	Dash Board Yellow	Cruscotto Giallo	Console Jaune	Konsole Gelbe	
15	422120154/0	1	Dash Board Red	Cruscotto Rosso	Console Rouge	Konsole Rote	
15	422120158/0	1	Dash Board Black	Cruscotto Nero	Console Noire	Konsole Schwarze	

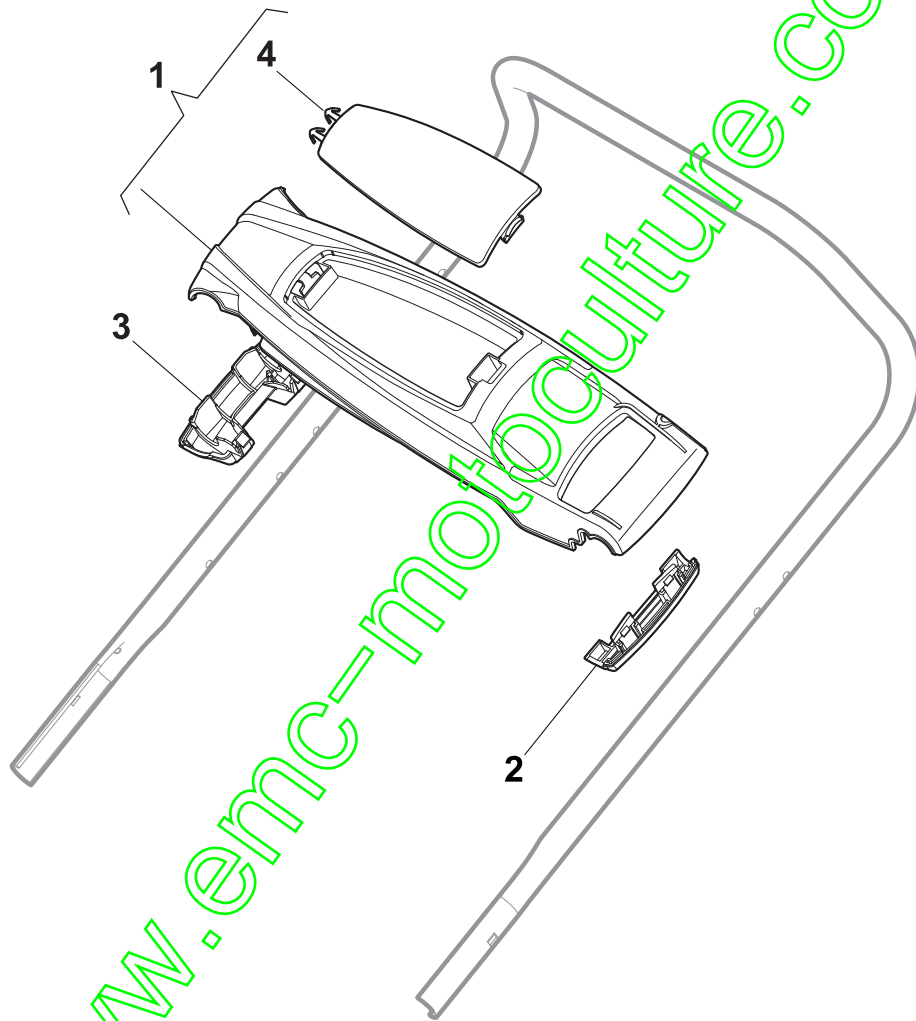

DELTA Dashboard

POS	PART. NO	Q.ty	DESCRIPTION	DESCRIZIONE	DESCRIPTION	BESCHREIBUNG	REMARKS
1	381124000/0	1	Dash Board Red	Cruscotto Rosso	Console Rouge	Konsole Rote	Red
1	381124001/0	1	Dash Board Yellow	Cruscotto Giallo	Console Jaune	Konsole Gelbe	Yellow
2	322546055/0	1	Plate	Piastrina	Plaquette	Plättchen	Red
2	322546057/0	1	Plate	Piastrina	Plaquette	Plättchen	Yellow
3	322546054/0	1	Plate	Piastrina	Plaquette	Plättchen	Red
3	322546056/0	1	Plate	Piastrina	Plaquette	Plättchen	Yellow
4	322120191/0	1	Dash Board Cover	Copertura Cruscotto	Console Couverture	Konsole Haube	

www.emc-motoculture.com

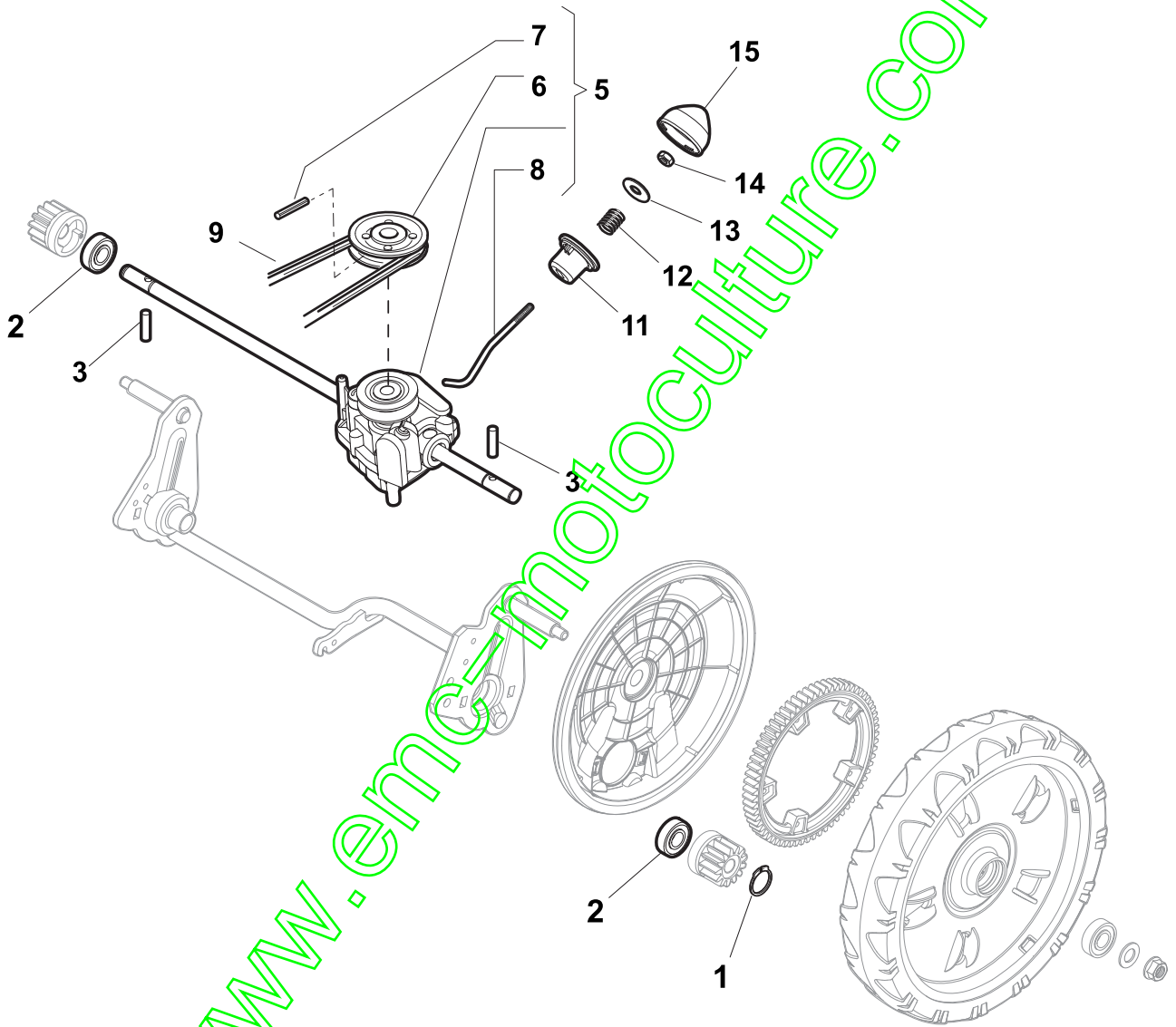

Rear Drive

POS	PART. NO	Q.ty	DESCRIPTION	DESCRIZIONE	DESCRIPTION	BESCHREIBUNG	REMARKS
1	112608600/0	2	Seeger	Seeger	Seeger	Seeger	
2	119216035/0	2	Bearing	Cuscinetto	Coussinet	Lager	
3	122753000/0	2	Pin	Perno	Pivot	Bolzen	
5	181003076/1	1	Gear Box	Gruppo Trazione	Groupe Traction	Antrieb	
6	122601904/0	1	Pulley	Puleggia	Poulie	Riemenscheibe	
7	112645705/0	1	Pin	Perno	Pivot	Bolzen	
8	122033283/0	1	Adjustment Rod	Asta Regolazione	Tige Reglage	Verstellungstange	
9	135063902/0	1	Belt	Cinghia	Courroire	Riemen	
11	122041957/1	1	Bush	Bussola	Douille	Büchse	
12	122450063/0	1	Spring	Molla	Ressort	Feder	
13	322680009/0	1	Washer	Rosetta	Rondelle	Scheibe	
14	112154510/0	1	Nut	Dado	Ecrou	Mutter	
15	122110230/0	1	Cap	Puntale	Bouchon	Gummistopfen	

www.emc-motoculture.com

DELTA Wheels - Ø 200

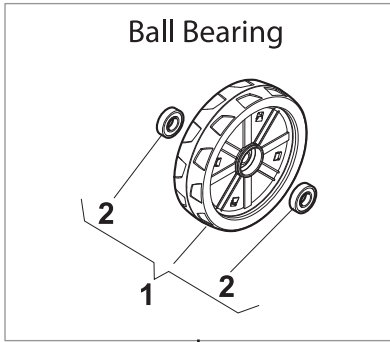

NTD Wheels - Ø 200

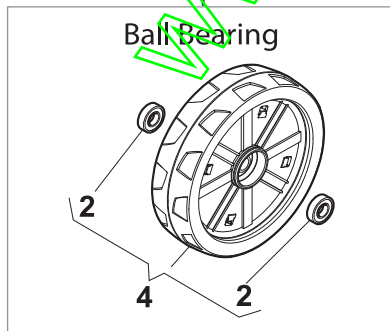
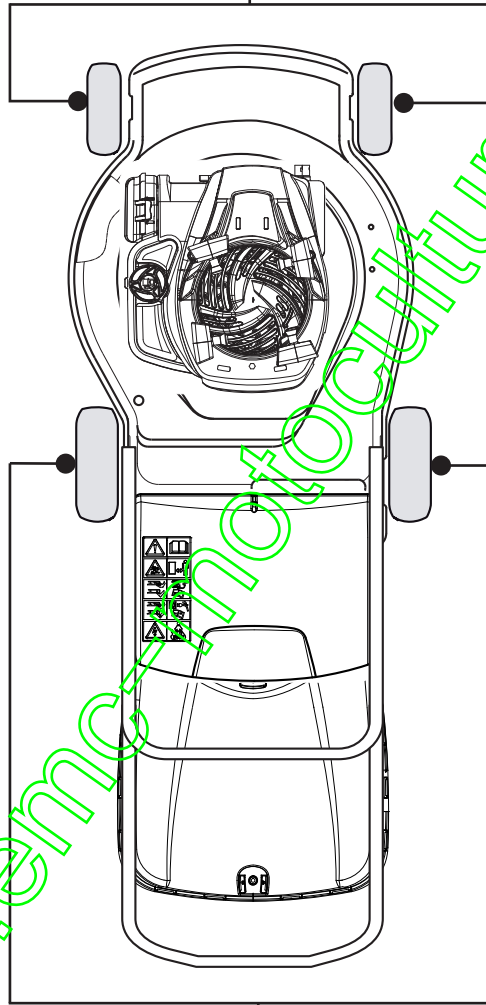
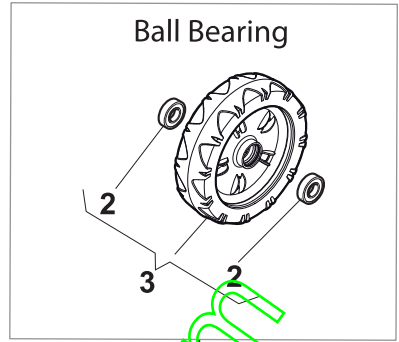

DELTA Wheels - Ø 280

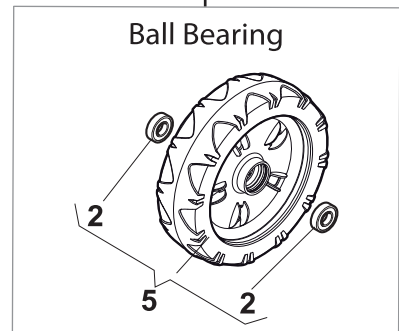

NTD Wheels - Ø 280

Wheels							
POS	PART. NO	Q.ty	DESCRIPTION	DESCRIZIONE	DESCRIPTION	BESCHREIBUNG	REMARKS
1	381007483/1	2	Wheel Ø 200	Ruota Ø 200	Roue Ø 200	Rad Ø 200	
2	119216035/0	8	Bearing	Cuscinetto	Coussinet	Lager	
3	381007416/2	2	Wheel Ø 200	Ruota Ø 200	Roue Ø 200	Rad Ø 200	
4	381007478/1	2	Wheel Ø 280	Ruota Ø 280	Roue Ø 280	Rad Ø 280	
5	381007417/2	2	Wheel Ø 280	Ruota Ø 280	Roue Ø 280	Rad Ø 280	

www.emc-motoculture.com

DELTA Wheel (Pierced) - Ø 200

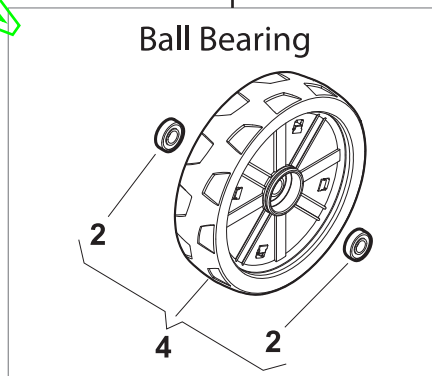
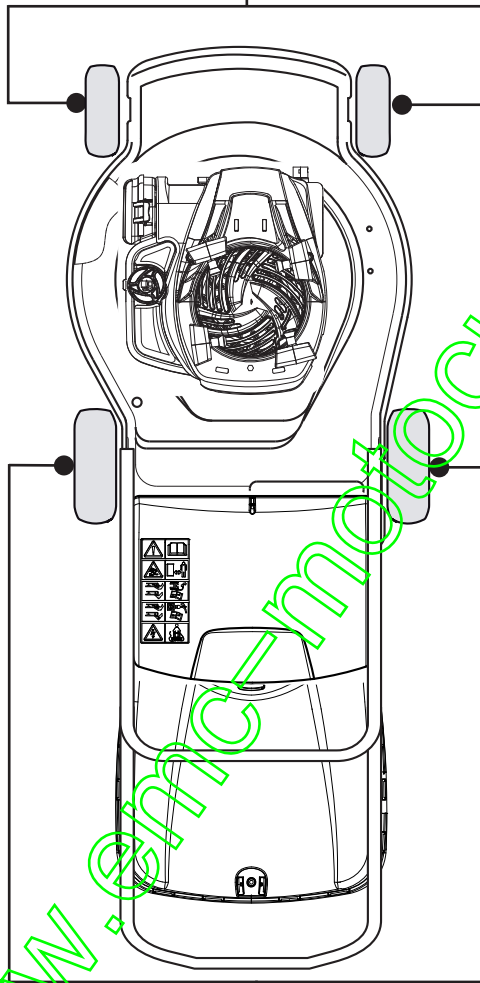
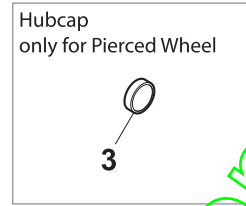
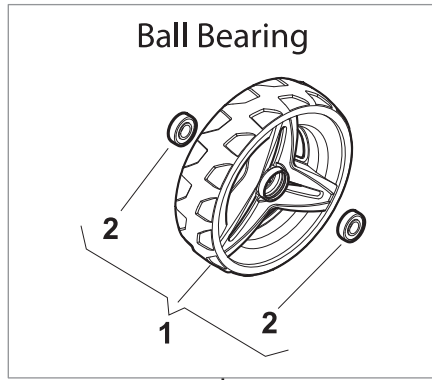

DELTA Wheel - Ø 280

DELTA Wheels with Bearing

POS	PART. NO	Q.ty	DESCRIPTION	DESCRIZIONE	DESCRIPTION	BESCHREIBUNG	REMARKS
1	381007477/0	2	Wheel Ø 200	Ruota Ø 200	Roue Ø 200	Rad Ø 200	
2	119216035/0	8	Bearing	Cuscinetto	Coussinet	Lager	
3	322110640/0	2	Hub Cap Grey	Coprizzo Grigio	Couvre-Moyeu Gris	Radkappe Grau	
4	381007478/1	2	Wheel Ø 280	Ruota Ø 280	Roue Ø 280	Rad Ø 280	

www.emc-motoculture.com

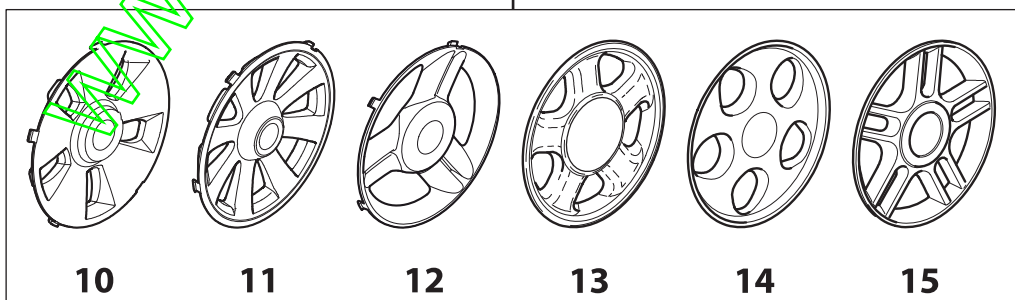
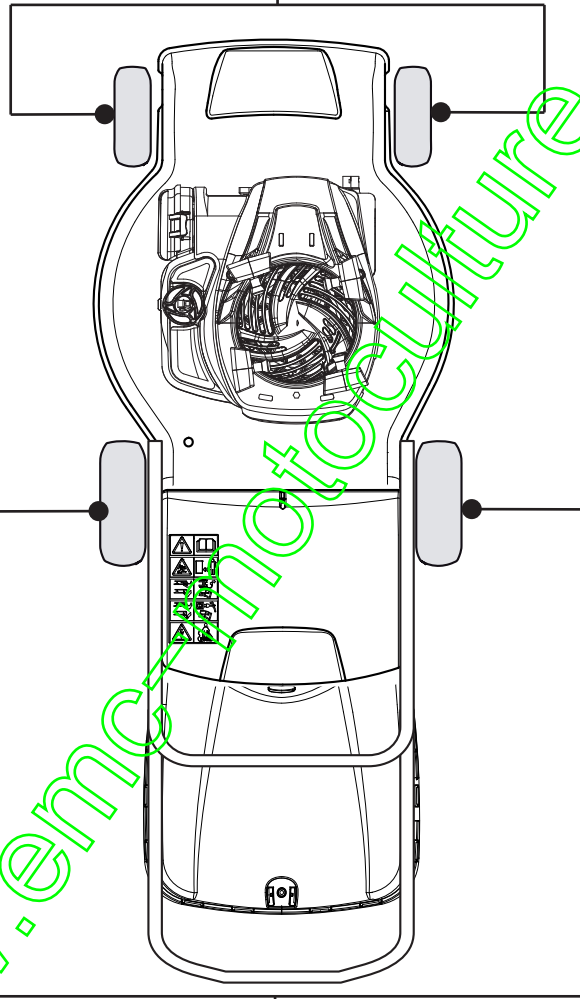
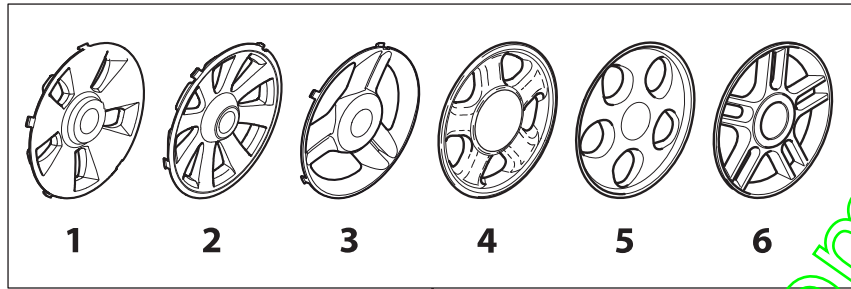

Hub Cap

POS	PART. NO	Q.ty	DESCRIPTION	DESCRIZIONE	DESCRIPTION	BESCHREIBUNG	REMARKS
1	322110643/0	2	Hub Cap Grey	Coprimitto Grigio	Couvre-Moyeu Gris	Radkappe Grau	
2	322110645/0	2	Hub Cap Grey	Coprimitto Grigio	Couvre-Moyeu Gris	Radkappe Grau	
2	322110649/0	2	Hub Cap Grey	Coprimitto Grigio	Couvre-Moyeu Gris	Radkappe Grau	
3	322110687/0	2	Hub Cap Grey	Coprimitto Grigio	Couvre-Moyeu Gris	Radkappe Grau	
4	322110382/0	2	Hub Cap Grey	Coprimitto Grigio	Couvre-Moyeu Gris	Radkappe Grau	
5	322110416/0	2	Hub Cap Grey	Coprimitto Grigio	Couvre-Moyeu Gris	Radkappe Grau	
6	322110492/0	2	Hub Cap Grey	Coprimitto Grigio	Couvre-Moyeu Gris	Radkappe Grau	
10	322110644/0	2	Hub Cap Grey	Coprimitto Grigio	Couvre-Moyeu Gris	Radkappe Grau	
11	322110646/0	2	Hub Cap Grey	Coprimitto Grigio	Couvre-Moyeu Gris	Radkappe Grau	
11	322110650/0	2	Hub Cap Yellow	Coprimitto Giallo	Couvre-Moyeu Jaune	Radkappe Gelb	
12	322110641/0	2	Hub Cap Grey	Coprimitto Grigio	Couvre-Moyeu Gris	Radkappe Grau	
13	322110511/0	2	Hub Cap Grey	Coprimitto Grigio	Couvre-Moyeu Gris	Radkappe Grau	
14	322110417/0	2	Hub Cap Grey	Coprimitto Grigio	Couvre-Moyeu Gris	Radkappe Grau	
15	322110560/0	2	Hub Cap Grey	Coprimitto Grigio	Couvre-Moyeu Gris	Radkappe Grau	

www.emc-motoculture.com

CARTER STANDARD (No Mulching)

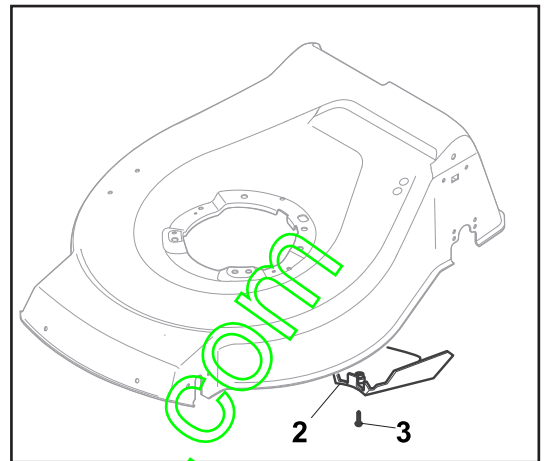

CARTER MULCHING (No Mulching)

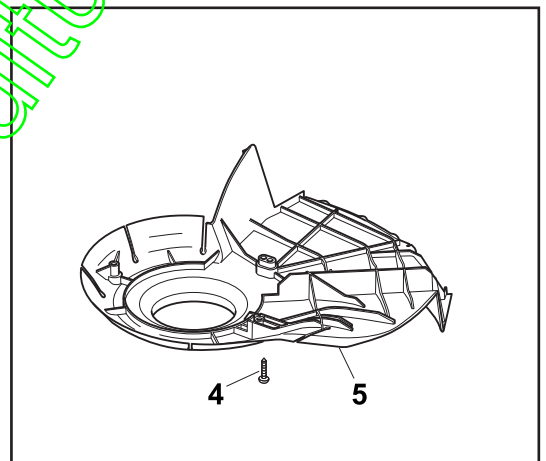

KIT MULCHING

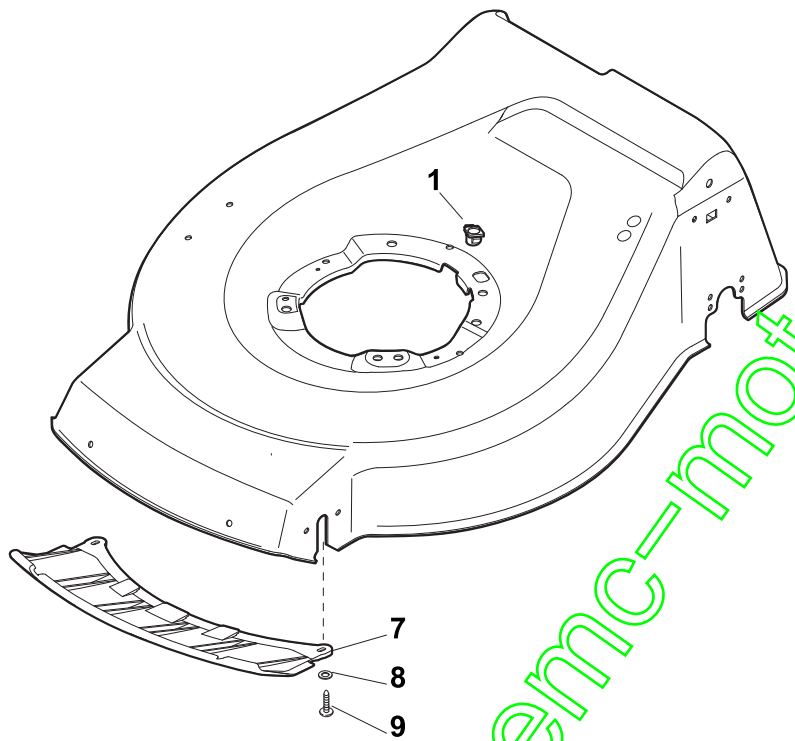
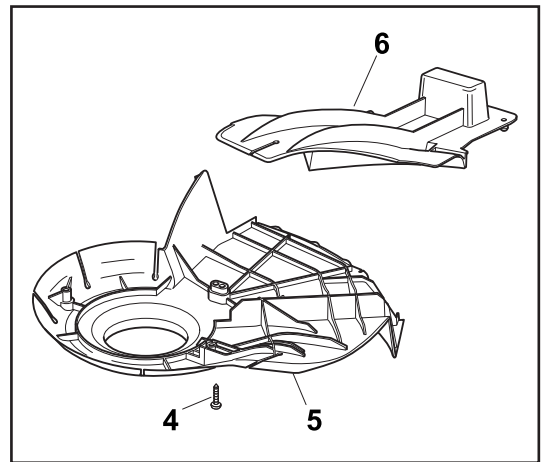

www.emc-motoculture.com

Carter							
POS	PART. NO	Q.ty	DESCRIPTION	DESCRIZIONE	DESCRIPTION	BESCHREIBUNG	REMARKS
1	322291150/0	1	Rubber Insert	Inserto In Gomma	Insert De	Gummi Einsatz	
2	122060193/0	1	Protection, Belt	Carter Cinghia	Protection Courroire	Schutz, Riemen	
3	112728530/0	1	Screw	Vite	Vis	Schraube	
4	112728530/0	3	Screw	Vite	Vis	Schraube	
5	322060197/3	1	Protection, Belt	Carter Cinghia	Protection Courroire	Schutz, Riemen	
6	122140222/0	1	Deflector	Deflettore	Deflecteur	Abweiser	
7	322500103/0	1	Front Combi	Pettine Anteriore	Vorne Comb	Peigne Avant	
8	112523000/1	2	Washer	Rosetta	Rondelle	Scheibe	
9	112728124/0	2	Screw	Vite	Vis	Schraube	

www.emc-motoculture.com

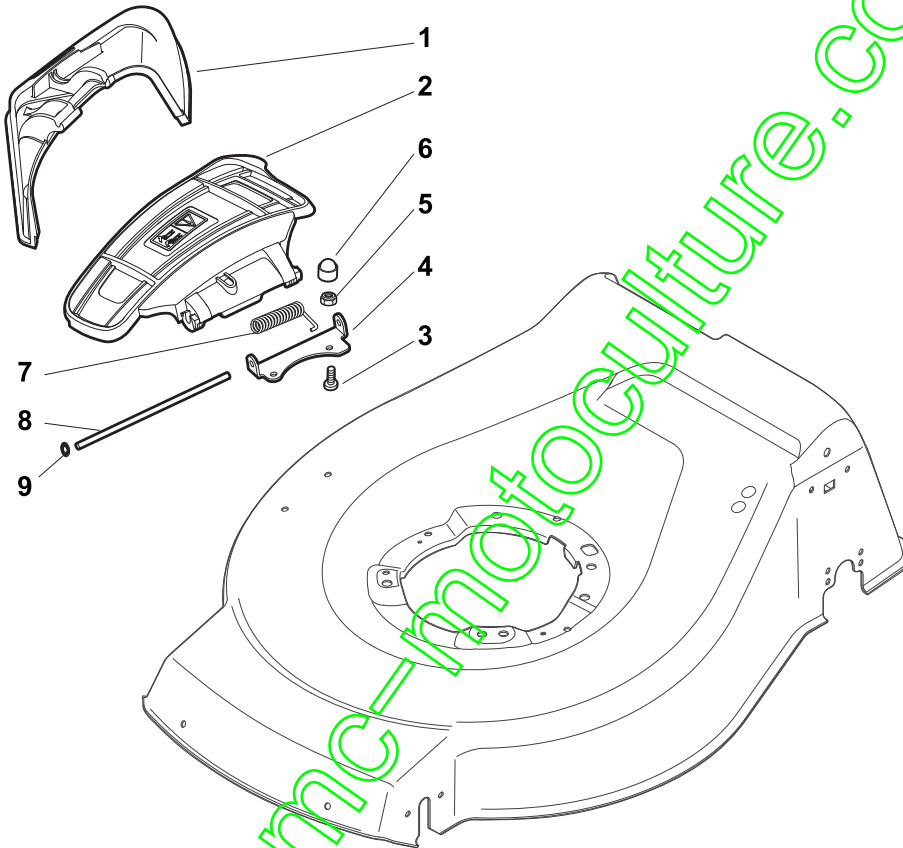

www.enc-motoculture.com

Side Discharge

POS	PART. NO	Q.ty	DESCRIPTION	DESCRIZIONE	DESCRIPTION	BESCHREIBUNG	REMARKS
1	322108295/0	1	Stone-Guard	Parasassi	Pare-Pierres	Prallblech	
2	322600195/0	1	Ejection Guard	Protezione Uscita	Protection Sortie	Auswurfschutz	
3	112727803/0	2	Screw	Vite	Vis	Schraube	
4	322806639/0	1	Fulcrum Pin	Perno Fulcro	Pivot	Gelenkpunkt	
5	112154510/0	2	Nut	Dado	Ecrou	Mutter	
6	118203853/0	2	Protection	Cappuccio	Capuchon	Stecker	
7	122450456/0	1	Spring	Molla	Ressort	Feder	
8	122517869/0	1	Pin	Perno	Pivot	Bolzen	
9	112604896/0	2	Crown Fastener	Fissatore A Corona	Fixateur A Couronne	Kronescheibe	

www.emc-motoculture.com

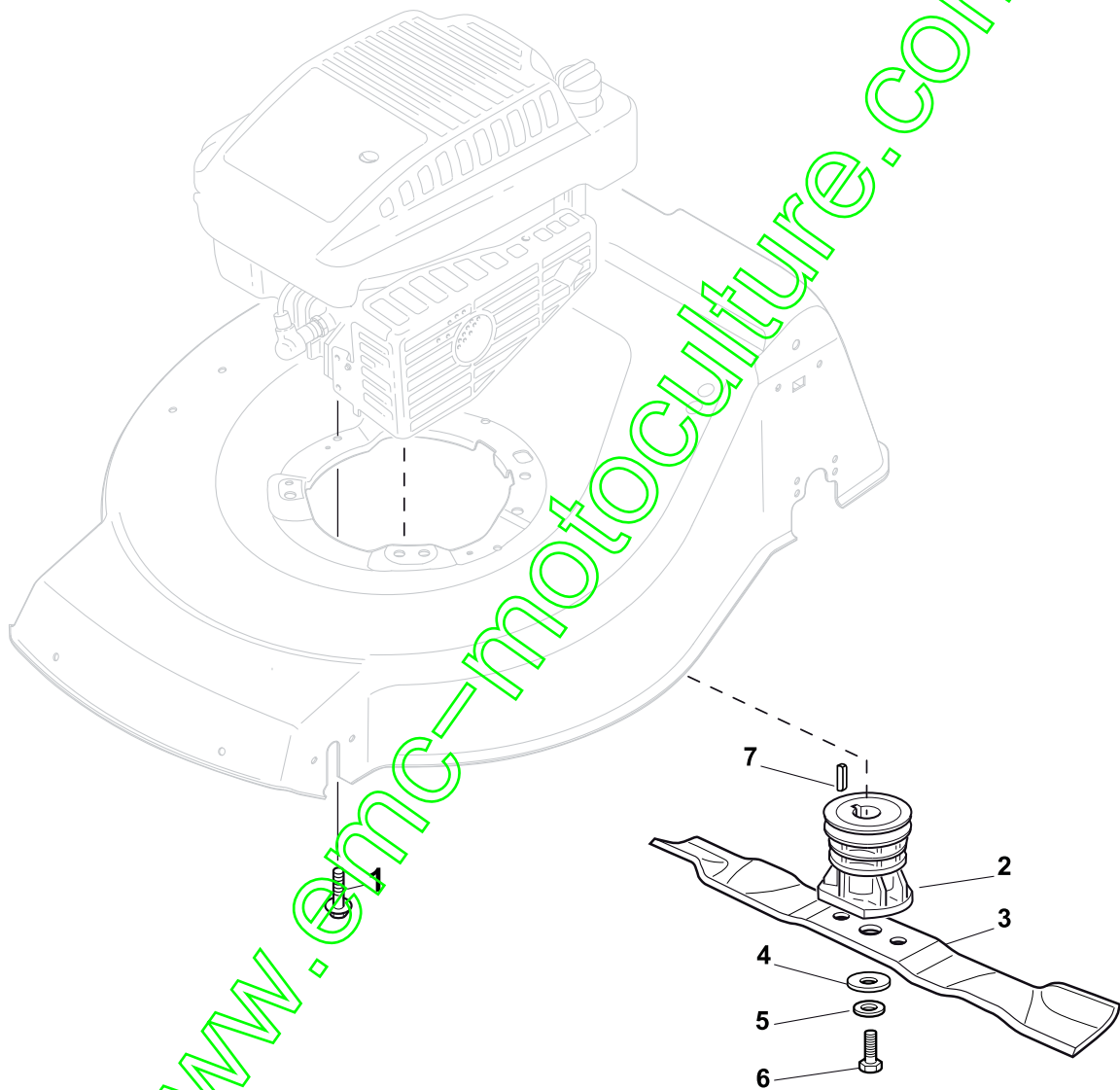

www.emc-motoculture.com

Blade							
POS	PART. NO	Q.ty	DESCRIPTION	DESCRIZIONE	DESCRIPTION	BESCHREIBUNG	REMARKS
1	112735108/1	2	Screw	Vite	Vis	Schraube	for GGP 196cc
1	112735108/1	3	Screw	Vite	Vis	Schraube	HONDA-GGP-B&S Engine
1	112735109/1	1	Screw	Vite	Vis	Schraube	for GGP 196cc
2	122465607/3	1	Hub With Pulley, Crankshaft Ø 22.2	Mozzo Con Puleggia, Albero Motore Ø 22.2	Moyeu Avec Poulie, Arbre Moteur Ø 22.2	Nabe Mit Scheibe, Motorwelle Ø 22.2	for B&S-GGP Engine
2	122465608/2	1	Hub With Pulley, Crankshaft Ø 25	Mozzo Con Puleggia, Albero Motore Ø 25	Moyeu Avec Poulie, Arbre Moteur Ø 25	Nabe Mit Scheibe, Motorwelle Ø 25	for Honda Engine
3	181004381/1	1	Blade Standard	Coltello Standard	Lame Standard	Messer Standard	
4	122160400/0	1	Elastic Washer	Disco Elastico	Disque Elastique	Federscheibe	
5	112523080/0	1	Washer	Rosetta	Rondelle	Scheibe	
6	112735698/0	1	Screw	Vite	Vis	Schraube	
7	112139100/0	1	Feather, Crankshaft Ø 22.2	Linguetta, Albero Motore Ø 22.2	Clavette, Arbre Moteur Ø 22.2	Keil, Motorwelle Ø 22.2	for B&S-GGP Engine
7	112139150/0	1	Feather, Crankshaft Ø 25	Linguetta, Albero Motore Ø 25	Clavette, Arbre Moteur Ø 25	Keil, Motorwelle Ø 25	for Honda Engine

www.emc-motoculture.com

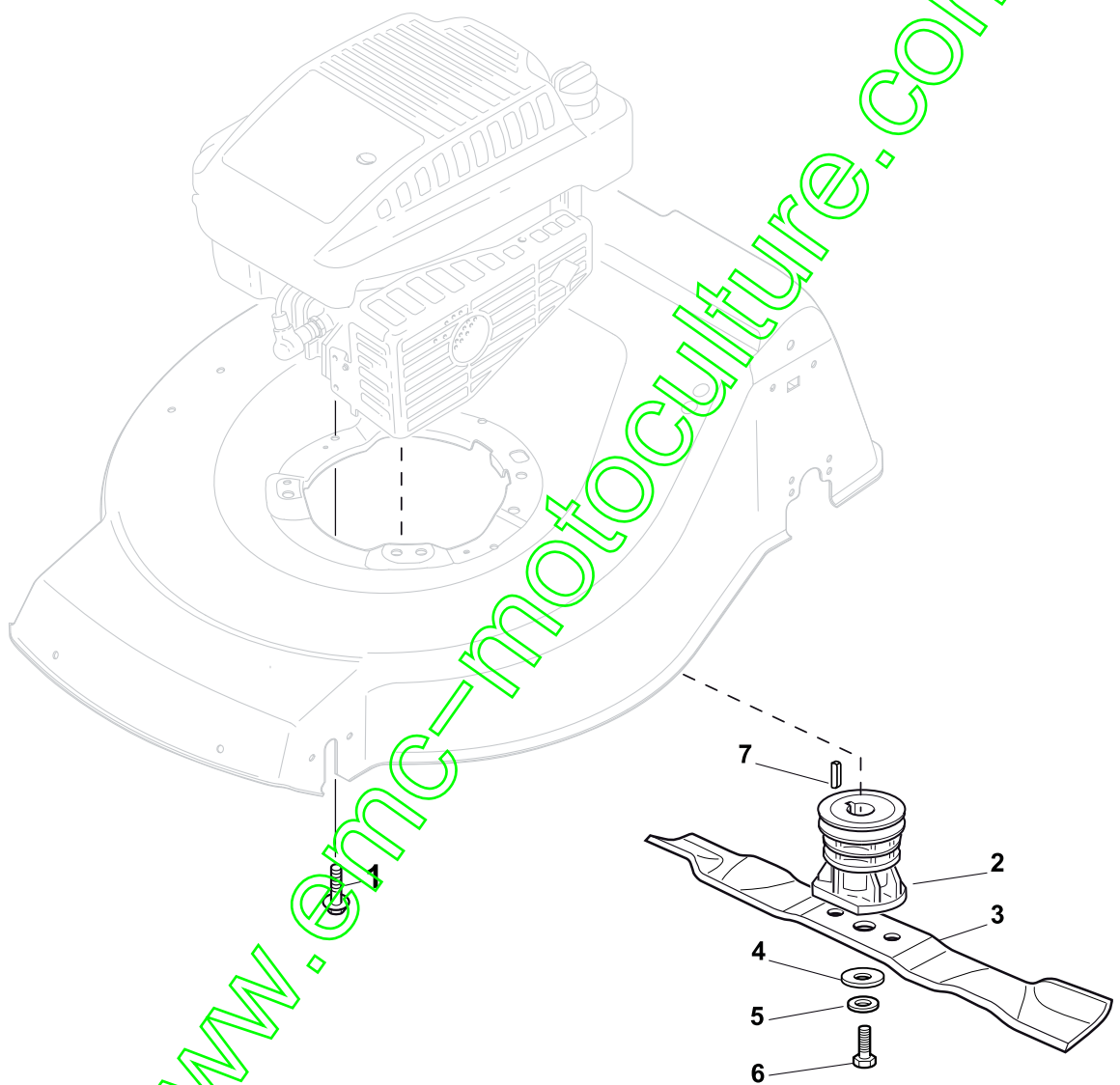

www.emc-motoculture.com

Blade for DELTA Grass-Catcher

POS	PART. NO	Q.ty	DESCRIPTION	DESCRIZIONE	DESCRIPTION	BESCHREIBUNG	REMARKS
1	112735108/1	2	Screw	Vite	Vis	Schraube	for GGP 196cc
1	112735108/1	3	Screw	Vite	Vis	Schraube	HONDA-GGP-B&S Engine
1	112735109/1	1	Screw	Vite	Vis	Schraube	for GGP 196cc
2	122465607/3	1	Hub With Pulley, Crankshaft Ø 22.2	Mozzo Con Puleggia, Albero Motore Ø 22.2	Moyeu Avec Poulie, Arbre Moteur Ø 22.2	Nabe Mit Scheibe, Motorwelle Ø 22.2	for B&S-GGP Engine
2	122465608/2	1	Hub With Pulley, Crankshaft Ø 25	Mozzo Con Puleggia, Albero Motore Ø 25	Moyeu Avec Poulie, Arbre Moteur Ø 25	Nabe Mit Scheibe, Motorwelle Ø 25	for Honda Engine
3	181004398/0	1	Blade Winged	Coltello Alettato	Lame Ailetteé	Messer Flügel	
4	122160400/0	1	Elastic Washer	Disco Elastico	Disque Elastique	Federscheibe	
5	112523080/0	1	Washer	Rosetta	Rondelle	Scheibe	
6	112735698/0	1	Screw	Vite	Vis	Schraube	
7	112139100/0	1	Feather, Crankshaft Ø 22.2	Linguetta, Albero Motore Ø 22.2	Clavette, Arbre Moteur Ø 22.2	Keil, Motorwelle Ø 22.2	for B&S-GGP Engine
7	112139150/0	1	Feather, Crankshaft Ø 25	Linguetta, Albero Motore Ø 25	Clavette, Arbre Moteur Ø 25	Keil, Motorwelle Ø 25	for Honda Engine

www.emc-motoculture.com

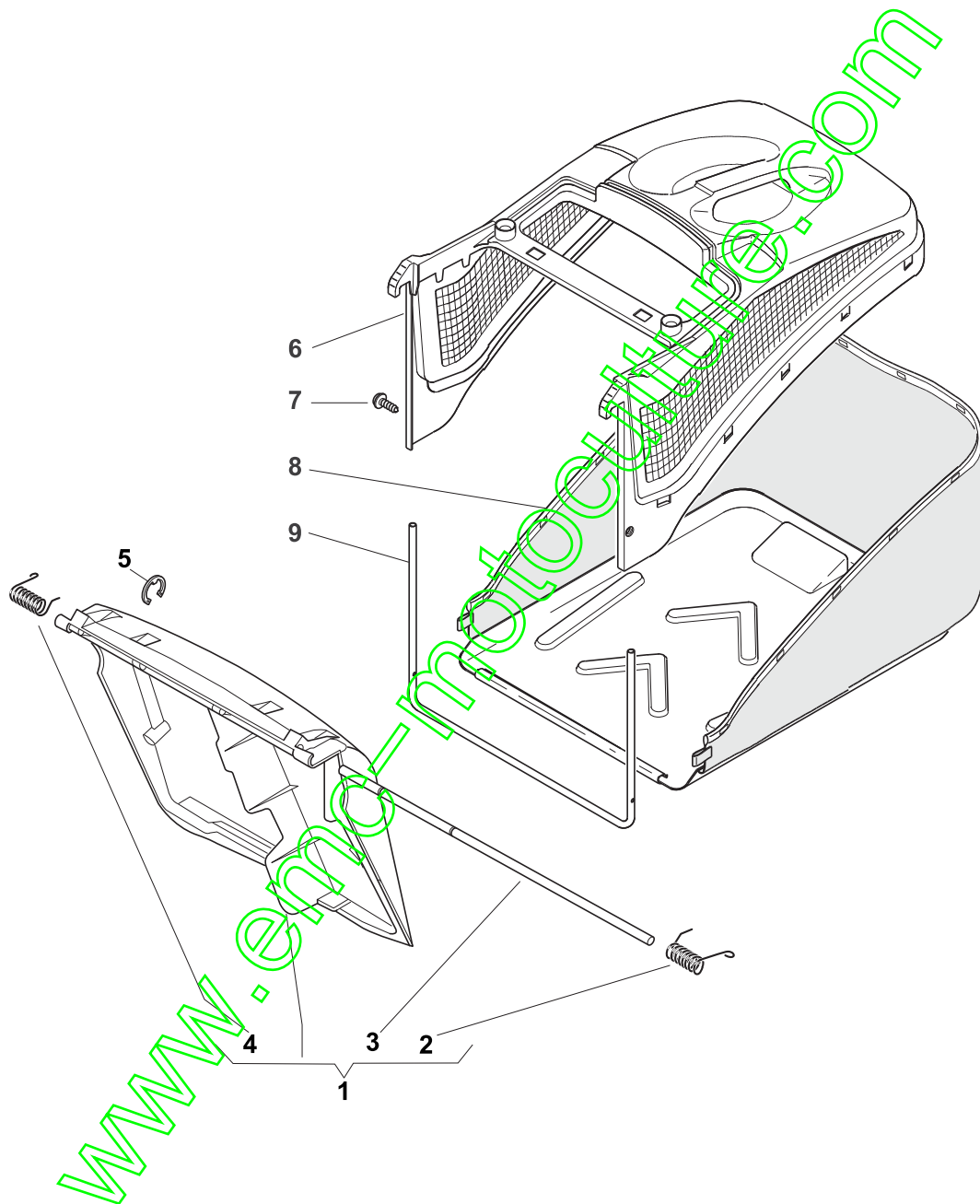

Hybrid Grass-Catcher

POS	PART. NO	Q.ty	DESCRIPTION	DESCRIZIONE	DESCRIPTION	BESCHREIBUNG	REMARKS
1	381008021/2	1	Stone-Guard	Parasassi	Pare-Pierres	Prallblech	
2	122450420/1	1	L Spring	Molla Sx	Ressort G	Linke Feder	
3	122517906/1	1	Pin	Perno	Pivot	Bolzen	
4	122450410/1	1	R Spring	Molla Dx	Ressort D	Rechte Feder	
5	112000930/0	1	Snap Ring	Anello Elastico	Anneau Ressort	Sprengring	
6	122486093/0	1	Grass-Box, Upper	Sacco, Parte Sup	Sac, Partie Superieure	Korb, Oberteil	
7	112728445/0	2	Screw	Vite	Vis	Schraube	
8	181002195/0	1	Box, Fabric	Sacco, Tela	Sac, Toile	Sack, Tuck	
9	122608523/0	1	Stiffening Lower	Rinforzo Inf	Réinforcement Inf	Verstärkung Untere	

www.emc-motoculture.com

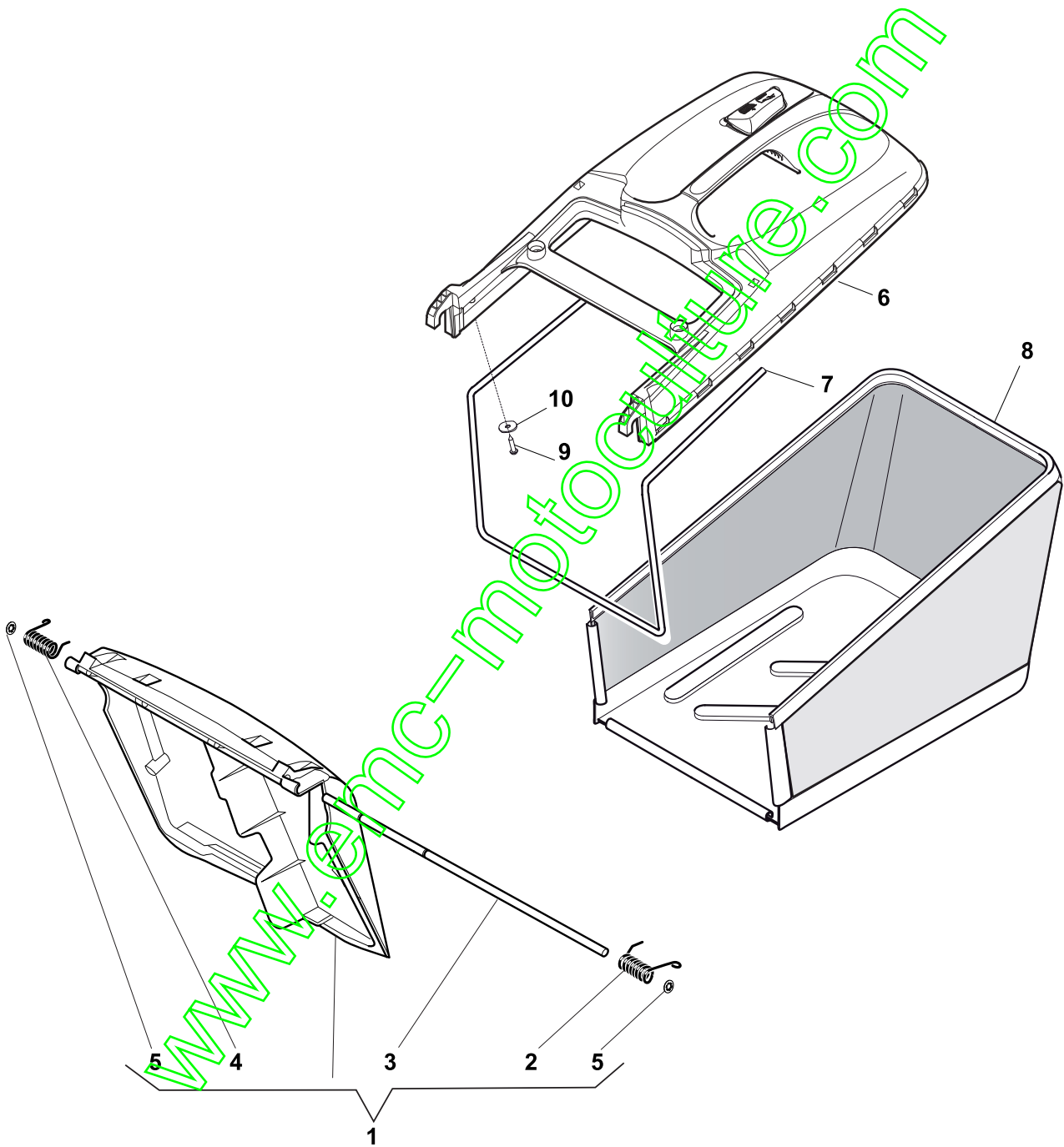

Hybrid Grass-Catcher

POS	PART. NO	Q.ty	DESCRIPTION	DESCRIZIONE	DESCRIPTION	BESCHREIBUNG	REMARKS
1	381008081/2	1	Stone-Guard Black	Parasassi Nero	Pare-Pierres, Noir	Prallblech, Schwarz	Black
1	381008082/2	1	Stone-Guard Yellow	Parasassi Giallo	Pare-Pierres, Jaune	Prallblech, Gelb	Yellow
2	122450466/0	1	L Spring	Molla Sx	Ressort G	Linke Feder	
3	122517882/0	1	Pin	Perno	Pivot	Bolzen	
4	122450465/0	1	R Spring	Molla Dx	Ressort D	Rechte Feder	
5	112604899/0	2	Crown Fastener	Fissatore A Corona	Fixateur A Couronne	Kronescheibe	
6	381486008/0	6	Grass-Box, Upper Part	Sacco, Parte Sup	Sac, Partie Superieure	Korb, Oberteil	Black
6	381486012/0	6	Grass-Box, Upper Part	Sacco, Parte Sup	Sac, Partie Superieure	Korb, Oberteil	Yellow
7	122608525/1	1	Stiffening Lower	Rinforzo Inf	Réinforcement Inf	Verstärkung Untere	
8	181002211/0	1	Box, Fabric	Sacco, Tela	Sac, Toile	Sack, Tuck	
9	112728680/0	2	Screw	Vite	Vis	Schraube	
10	112523050/0	2	Washer	Rosetta	Rondelle	Scheibe	

www.emc-motoculture.com

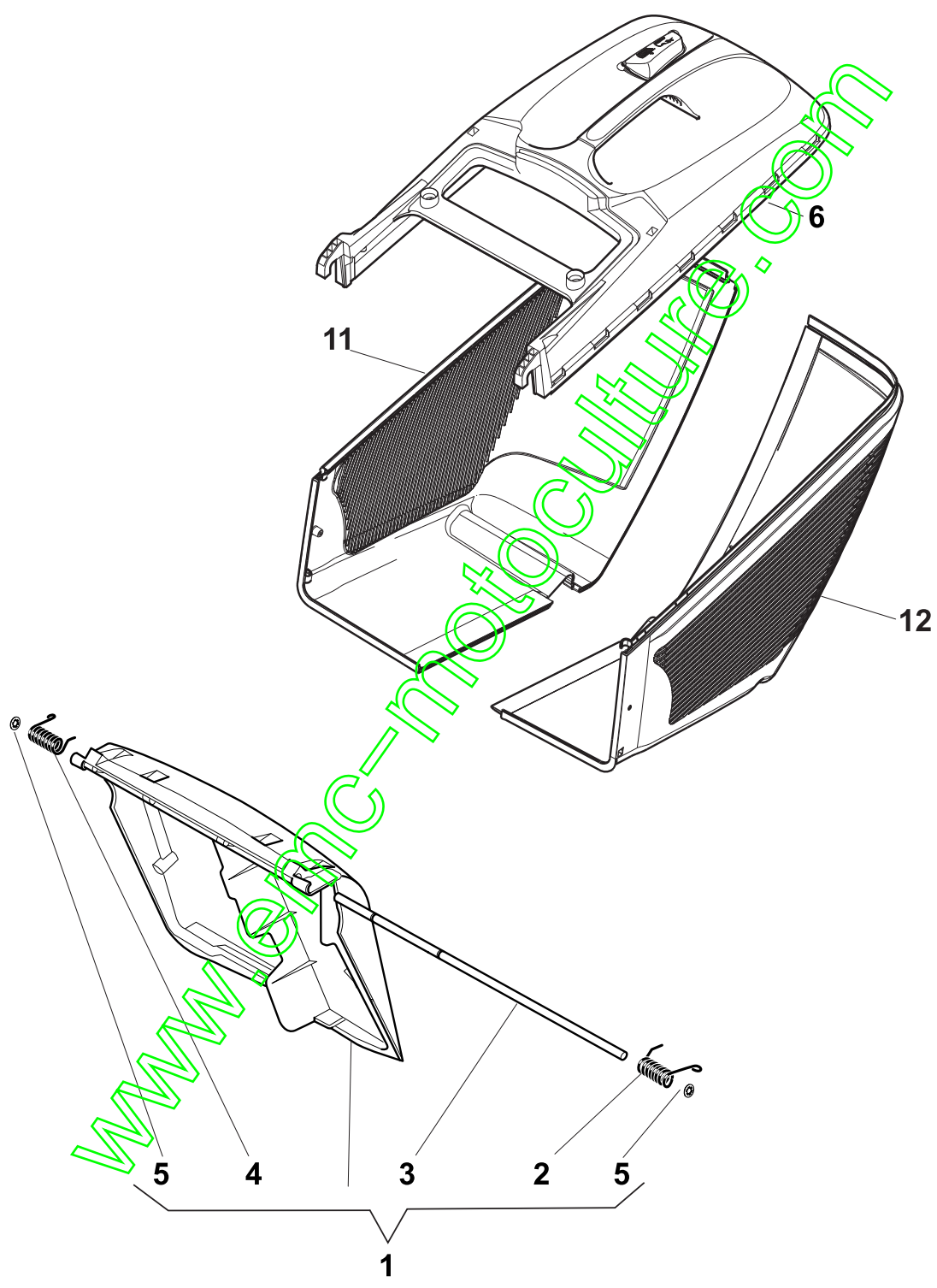

Plastic Grass-Catcher

POS	PART. NO	Q.ty	DESCRIPTION	DESCRIZIONE	DESCRIPTION	BESCHREIBUNG	REMARKS
1	381008081/2	1	Stone-Guard Black	Parasassi Nero	Pare-Pierres, Noir	Prallblech, Schwarz	Black
1	381008082/2	1	Stone-Guard Yellow	Parasassi Giallo	Pare-Pierres, Jaune	Prallblech, Gelb	Yellow
2	122450466/0	1	L Spring	Molla Sx	Ressort G	Linke Feder	
3	122517882/0	1	Pin	Perno	Pivot	Bolzen	
4	122450465/0	1	R Spring	Molla Dx	Ressort D	Rechte Feder	
5	112604899/0	2	Crown Fastener	Fissatore A Corona	Fixateur A Couronne	Kronescheibe	
6	381486008/0	6	Grass-Box, Upper Part	Sacco, Parte Sup	Sac, Partie Superieure	Korb, Oberteil	Black
6	381486012/0	6	Grass-Box, Upper Part	Sacco, Parte Sup	Sac, Partie Superieure	Korb, Oberteil	Yellow
11	322486150/1	1	Grass-Box, R Lower	Sacco, Parte Inf Dx	Sac, Partie Inferieure D	Korb, R Unterteil	
12	322486151/1	1	Grass-Box, L Lower	Sacco, Parte Inf Sx	Sac, Partie Inferieure G	Korb, L Unterteil	

www.emc-motoculture.com

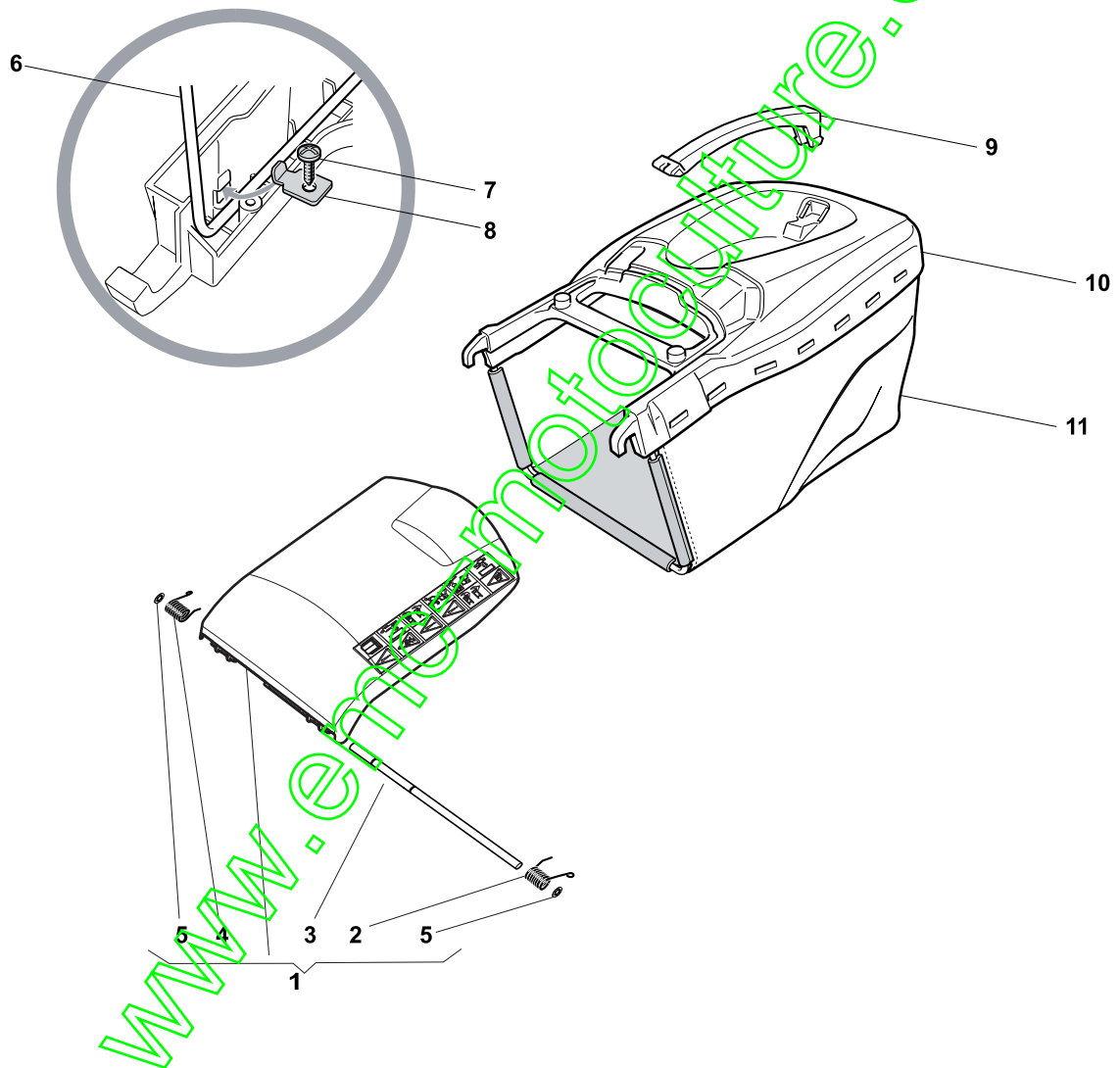

Hybrid Grass-Catcher, DELTA

POS	PART. NO	Q.ty	DESCRIPTION	DESCRIZIONE	DESCRIPTION	BESCHREIBUNG	REMARKS
1	381008128/0	1	Stone-Guard	Parasassi	Pare-Pierres	Prallblech	
2	122450466/0	1	L Spring	Molla Sx	Ressort G	Linke Feder	
3	122517882/0	1	Pin	Perno	Pivot	Bolzen	
4	122450465/0	1	R Spring	Molla Dx	Ressort D	Rechte Feder	
5	112604899/0	2	Crown Fastener	Fissatore A Corona	Fixateur A Couronne	Kronescheibe	
6	122608505/0	1	Stiffening	Rinforzo	Renforcement	Verstaerkung	
7	112728680/0	2	Screw	Vite	Vis	Schraube	
8	322545159/0	2	Plate	Piastrina	Plaquette	Plättchen	
9	322393657/0	1	Handle	Maniglia	Poignée	Griff	
10	381486009/0	1	Grass-Box, Upper	Sacco, Parte Sup	Sac, Partie Superieure	Korb, Oberteil	
11	181002345/0	1	Box, Fabric	Sacco, Tela	Sac, Toile	Sack, Tuck	

www.emc-motoculture.com

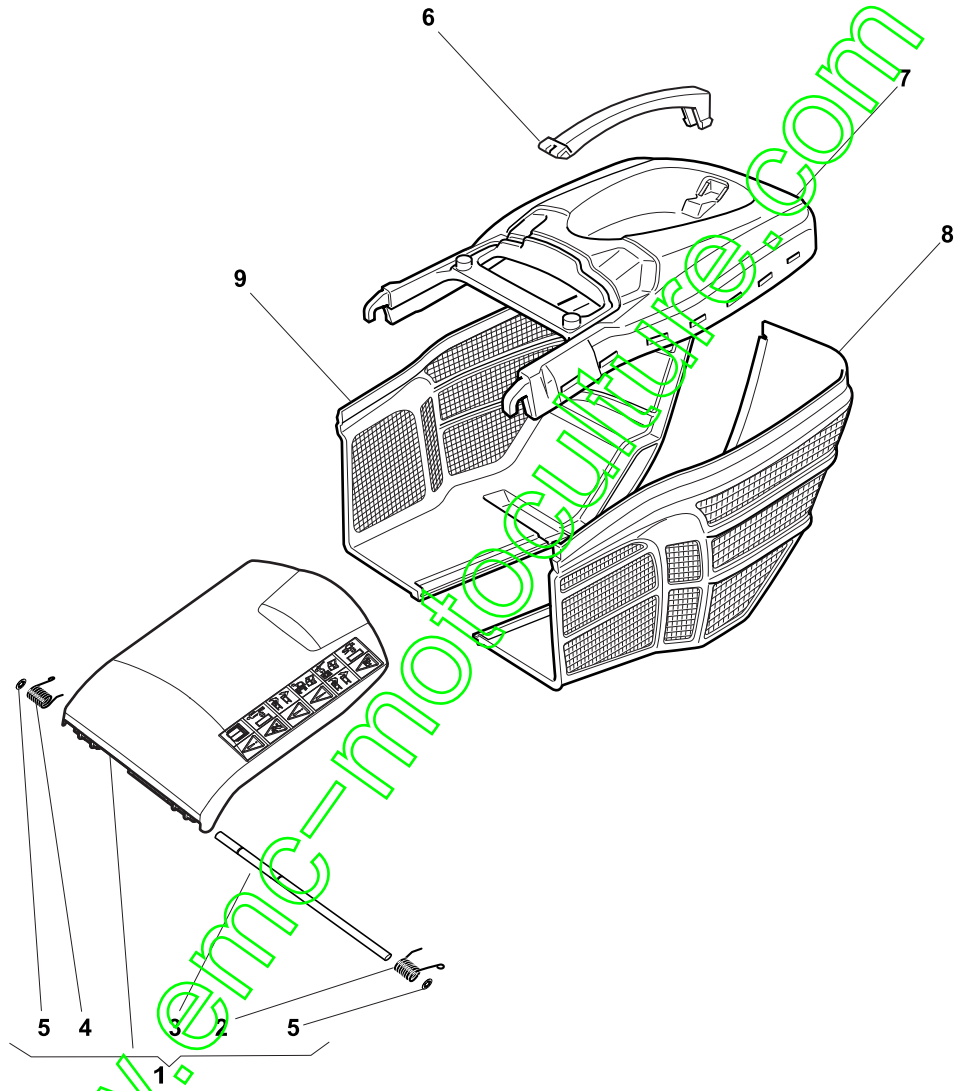

Plastic Grass-Catcher, DELTA

POS	PART. NO	Q.ty	DESCRIPTION	DESCRIZIONE	DESCRIPTION	BESCHREIBUNG	REMARKS
1	381008128/0	1	Stone-Guard	Parasassi	Pare-Pierres	Prallblech	
2	122450466/0	1	L Spring	Molla Sx	Ressort G	Linke Feder	
3	122517882/0	1	Pin	Perno	Pivot	Bolzen	
4	122450465/0	1	R Spring	Molla Dx	Ressort D	Rechte Feder	
5	112604899/0	2	Crown Fastener	Fissatore A Corona	Fixateur A Couronne	Kronescheibe	
6	322393657/0	1	Handle	Maniglia	Poignée	Griff	
7	381486009/0	1	Grass-Box, Upper	Sacco, Parte Sup	Sac, Partie Superieure	Korb, Oberteil	
8	322486306/0	1	Grass-Box, L Lower	Sacco, Parte Inf Sx	Sac, Partie Inferieure G	Korb, L Unterteil	
9	322486305/0	1	Grass-Box, R Lower	Sacco, Parte Inf Dx	Sac, Partie Inferieure D	Korb, R Unterteil	

www.emc-motoculture.com