

Position	Numéro de pièce	#	Appellation I	Appellation II	Remarque
1	731-0220	1	COUVERCLE / VOLANT	731-0220	
1A	731-1459	1	COUVERCLE BOUCHON /VOLANT	731-1459	quarrée
1B	731-1460	1	COUVERTURE VOLANT	731-1460 schwarz/viereckig	quarrée avec logo
2	712-0411	1	ÜCROU HEXAGONAL	FINISH:701-01000	
3	736-0242	1	RONDELLE CONIQUE.340X.872X.060	FINISH:MTD STD 701-01001	
4	731-0805	1	VOLANT	731-0805/931-0805	seulement pour couvercle rond,Volant 3 rayo
4A	731-1406	1	VOLANT	731-1406	seulement pour couvercle carré,Volant 3 rayo
4B	731-0806A	1	VOLANT 34 CM 13,25" 4 RAYO	731-0806A/931-0806A	seulement pour couvercle rond
5	731-0954	1	SOUFFLET GOMMEUX	731-0954	
5A	731-1542	1	SOUFFLET	731-1542	seulement pour style 7
6	737-0280	1	GRAISSEUR	737-0280 / 937-0280	
7	741-0587	1	SUPPORT	FINISH:NATUR	
9	17198A	1	PLAQUE	17198A	
10	738-0141	1	AXE		
11	710-0152	1	VIS HCCS:3/8- 24:1.00:GR5:STD	910-0152	
13	750-0535	1	ENTRETOISE	FINISH:GEÖLT	
14	736-0217	1	RONDELLE GROWER	FINISH:701-01001	
15	710-0726	1	VIS 5/16- 12:0.750:HXINDWS	FINISH:MTD STD 701-01002	
16	711-1001	1	TIGE EX 711-0788	711-1001 RB 753- 0655	
17	783-0041	1	VOIR 783-0041A	783-0041A-0637	
18	738-0527	1	BOULON	738-0527	

Position	Numéro de pièce	#	Appellation I	Appellation II	Remarque
19	712-0431	1	ÜCROU STOP 3/8-16:GRF	FINISH:MTD SPEC-100015	
20	736-0169	1	BAGUE ÜLASTIQUE	FINISH:MTD SPEC-100016	
21	712-0411	1	ÜCROU HEXAGONAL	FINISH:701-01000	
22	16481A	1	VOIR 983-0055	16481A	
23	710-0772	1	VIS HEX.:5/16-24X2.00	710-0772	
24	741-0487A	1	PALIER DE BRIDE	741-0487A (BR.748-0184)	
25	683-0002	1	VOIR 753-0642-0637	683-0002	
26	17585A	1	AXE AVANT COMPL. GAUCHE	SCHWEISSTEIL: 97585A-0637	
26A	683-0041A	1	AXE AVANT GAUCHE	683-0041A/983-0041A SCHWARZ	
27	712-0241	1	ÜCROU HEX.: 3/8-24:GR5	FINISH:MTD STD 701-01000	
28	736-0169	1	BAGUE ÜLASTIQUE	FINISH:MTD SPEC-100016	
29	723-3018	1	ROTULE DE DIRECTION 3/8-24	FINISH:N/A	
30	747-0753	1	KIT TRINGLE DIRECTION	E-TEIL-SET	ajustable
30A	747-0861	1	VOIR 747-0861-0637	747-0861-0637	non ajustable
31	712-0711	1	ÜCROU HEXAGONAL	MTD SPEC-100015 912-0711	
32	17584A	1	AXE AVANT DROIT	FINISH:SIEHE ZG: 97584A	
32A	683-0040A	1	AXE AVANT DROIT	3.41 X 4.05	
33	634-0056	2	ROUE COMPL 15X16 CUIR PLAST		15" x 6" avec roulement de plastique
33A	634-0059	2	ROUE COMPL 15,0x6,0 AVEC	634-0059-0912/0662	15" x 6" avec roulement à bille
33B	634-0057	2	ROUE COMPL 13x5	634-0057-0911	13" x 5" avec roulement de plastique
33C	634-0073	2	ROUE COMPL 13"x5"	634-0073	13" x 5" avec roulement à bille

Position	Numéro de pièce	#	Appellation I	Appellation II	Remarque
34	634-0024	2	JANTE 6.0 x 4.5 x .81 ID	634-0024-0662	seulement pour 15" x 6" avec roulement de plastique
34A	634-0051	2	JANTE 6;0 x 4,5 BB	634-0051-0662	seulement pour 15" x 6" avec roulement à bille
34B	734-1227	2	JANTE	734-1227	seulement pour 13" x 5" avec roulement de plastique
34C	634-0072	2	JANTE	634-0072	seulement pour 13" x 5" avec roulement à bille
35	741-0487A	4	PALIER DE BRIDE	741-0487A (BR.748-0184)	
35A	741-0569	4	ROULEMENT DE ROUE AVANT	741-0569	
36	736-0285	1	RONDELLE .635 X 1.589 X .06	FINISH:701-01000	
37	731-0484A	1	ENJOLIVEUR DEVANT	KUNSTSTOFF SCHWARZ 931-0484A	
37A	731-1787A	1	731-09693	731-1787A	
37B	734-1613A	1	ENJOLIVEUR 6" gris		
37C	734-1612A	1	ENJOLIVEUR 6"		
38	714-0470	1	EPINGLE EX AF-43010	FINISH:SPEC-100015 470 32 32	
39	736-0187	1	RONDELLE .64X1.24X.06	FINISH:MTD SPEC 701-01001	
40	726-0214	1	BOUCHON	FINISH:SCHWARZ	
42	712-0446	1	ECROU	712-0446	
43	710-0538	1	VIS HEX.:5/16-18:.625:GR.5:LOC	FINISH:701-01000	
44	736-0119	1	RONDELLE	FINISH:MTD STD 701-01001	
45	736-0343	1	RONDELLE .330 ID X 1.25 X .12	FINISH:MTD 701-100015	
46	750-0532	1	ENTRETOISE 980IDX1.250DX.0420		

Position	Numéro de pièce	#	Appellation I	Appellation II	Remarque
47	712-0214	1	ECROU	FINISH:701-01000	
48	736-0169	1	BAGUE ÜLASTIQUE	FINISH:MTD SPEC-100016	
49	712-0158	1	ECROU EX AF-43064	FINISH:701-01000	
50	736-0119	1	RONDELLE	FINISH:MTD STD 701-01001	
51	717-0622A	1	SEGMENT DE DIRECTION	717-0622A	
52	741-0225	1	BAGUE HEXAGONALE TEFLON 6 PANS	FINISH:KUNSTSTOFF SCHWARZ	
53	736-0187	1	RONDELLE .64X1.24X.06	FINISH:MTD SPEC 701-01001	
54	738-0743	1	ARBRE DE DIRECTION	738-0743	
57	710-0837	1	VIS	FINISH:MTD STD 701-01002	
58	736-0271	1	RONDELLE	FINISH:701-01001	
59	736-0187	1	RONDELLE .64X1.24X.06	FINISH:MTD SPEC 701-01001	
60	723-3018	1	ROTULE DE DIRECTION 3/8-24	FINISH:N/A	
61	736-0607	1	RONDELLE	FINISH:MTD STD 701-01001	
63	727-0425A	1	CLIP ENJOLIVEUR		
64	736-0356	1	RONDELLE	FINISH:MTD STD 701-01001	
65	731-1291	1	PALIER DE GRAISSAGE	731-1291	
66	710-0459	1	VIS	710-0459 / 910-0459	
69	731-1389	1	DOUILLE EN PLASTIQUE	731-1389	
70	731-0955	1	PROTEGE VOLANT	731-0955	
72	738-0886	1	COLONNE DE DIRECTION STYLE 7	738-0886	
73	650-0001	1	ARBRE DE DIRECTION	650-0001	
74	710-0958	1	VIS	FINISH:701-01000	
75	712-0324	1	ÜCROU HEX.:1/4-20:GR8:NYLON	FINISH:701-01000	
76	734-1731	2	PNEU 15X600X6 DICO MULTI-TRAC	FINISH:	

Position	Numéro de pièce	#	Appellation I	Appellation II	Remarque
76A	734-0298	2	PNEU 13*500*6	734-0298-0901/-0902 000.75.551	
77	734-0255	2	VALVE:PNEU	TR 412-P / 32.6mm / 934-0255	
78	737-0211	2	GRAISSEUR	737-0211	Roulement de plastique
78A	737-0280	2	GRAISSEUR	737-0280 / 937-0280	Roulement à billes
79	737-0212	2	GRAISSEUR	737-0212	Roulement de plastique

www.emc-motoculture.com

RMS 13-96 > [135N674F628 \(1995\)](#) >
[Entraînement de roulement, Poulie moteur, Pedale, Roues arrière](#)

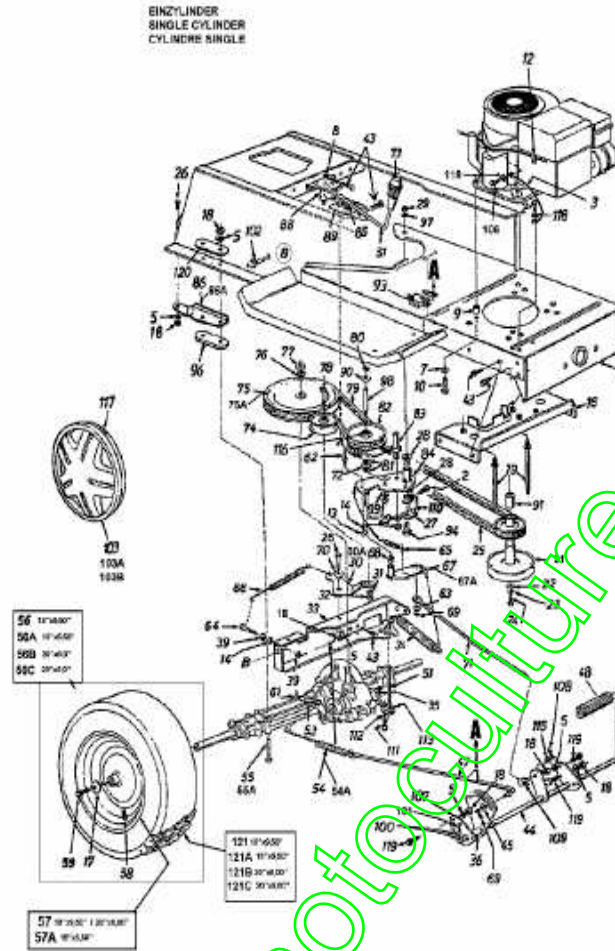

Position	Numéro de pièce	#	Appellation I	Appellation II	Remarque
2	710-0726	1	VIS 5/16-12:0.750:HXINDWS	FINISH:MTD STD 701-01002	
3	725-0980	1	CABLE	725-0980	
5	736-0119	1	RONDELLE	FINISH:MTD STD 701-01001	
7	736-0247	1	RONDELLE 40 X 1.25X .157"	FINISH:MTD SPEC 701-01001	
8	736-0222	1	RONDELLE	FINISH:MTD STD 701-01001	
9	750-0965	1	ENTRETOISE	750-0965	
10	710-1007	1	VIS HEX.TTSEMS3/8-16:1,500	FINISH:STD 701-01002 or 101616	
11	683-0065	1	CHASSIS BAS COMPL	683-0065-0637	
12	726-0235	1	CLIP	726-0235	
13	712-0287	1	ÜCROU HEXAGONAL 1/4-20:GR2	FINISH:701-01000 / 912-0287	
14	736-0329	1	RONDELLE GROWER	FINISH:701-01001 24.8195.16	
16	17893A	1	PROTECTION COURROIE	17893A-0637	
17	736-0242	1	RONDELLE CONIQUE.340X.872X.060	FINISH:MTD STD 701-01001	
18	712-0267	1	ÜCROU HEXAGONAL	FINISH:MTD STD 701-01000	
19	711-0986	1	PROTEGE COURROIE	711-0986 / 911-0986	
21	756-0982	1	POULIE	756-0982	
22	736-0322	1	RONDELLE .450 X 1.250 X .164	FINISH:701-01001 936-0322	
23	736-0171	1	RONDELLE GROWER	FINISH:MTD STD 701-01001	
24	710-0757	1	VIS	FINISH:701-01000 910-0757	
25	754-0280	1	COURROIE MOTEUR/VARIATEUR	754-0280 / 954-0280	
26	710-0118	1	VIS	FINISH:PHOS & OIL	
27	17963	1	SUPPORT ARBRE	17963	
28	741-0591	1	BAGUE	FINISH:NATUR 941-0591	
29	712-0241	1	ÜCROU HEX.: 3/8-24:GR5	FINISH:MTD STD 701-01000	
30	17643	1	SUPPORT	17643-0637	
30A	17694	1	SUPPORT	FINISH:SIEHE ZG.	

Position	Numéro de pièce	#	Appellation I	Appellation II	Remarque
31	736-0169	1	BAGUE ÜLASTIQUE	FINISH:MTD SPEC-100016	
32	712-0241	1	ÜCROU HEX.: 3/8-24:GR5	FINISH:MTD STD 701-01000	
33	17629A	1	SUPPORT TRANSMISSION	17629A-0637	
34	732-0556	1	RESSORT EX 732-0436	FINISH:MTD STD 701-01006	
35	714-0149B	1	GOUPILLE FENDUE 1/2"	714-0149B	
36	750-0802	1	ENTRETOISE / .640IDX.760DX2.63	FINISH:KUNSTSTOFF SCHWARZ	
39	712-0138	1	ÜCROU HEX. 1/4-28"	712-0138	
43	710-0599	1	VIS i SIX PANS CREUX	MTD SPEC-701-01002 or 101617	
44	17715B	1	PEDALE EMBRAYAGE + FREINS COM	17715B-0637	
45	736-0264	1	RONDELLE: .330 x.630 x.0635	FINISH:701-01000 936-0264	
47	17686A	1	TIGES DE FREIN	17686A	
48	735-0196	1	GARNITURE PEDALE 46 LG	FINISH:SCHWARZ	
51	17705	1	LEVIER	17705	
53	732-0264	1	RESSORT	FINISH:SPEC-701-01006 932-0264	
54	732-0413	1	RESSORT DE TRACTION	FINISH:PHOS & OIL	seulement pour 20" roues sans 46" plateau de coupe
54A	732-0642	1	RESSORT	732-0642/932-0642	seulement pour 18" roues ou 46" plateau de coupe
55	710-0189	1	VIS HEX.:5/16-18x3.00:GR5:STD	701-01000 or 101616 910-0189	seulement pour 20" roues sans 46" plateau de coupe
55A	710-1068	1	VIS	710-1068	seulement pour 18" roues ou 46" plateau de coupe
56	734-0817	2	ROUE COMPL 18X9,50-8 ST ELEC	734-0817662/-674/-WY/-CB	

Position	Numéro de pièce	#	Appellation I	Appellation II	Remarque
56A	734-0592	2	ROUE COMPL 18X6.50-8 ST	734-0592662/-G/-674/-Y/-CB/-WY	
56B	734-1675	2	ROUE COMPL 20X8;00-8 ST	734-1675-0911	profile arrondi
56C	634-0104	2	ROUE COMPL 20" x 8" BEIGE	634-0104662/-G/-674/-Y/-CB/-WY	Pneus profile plat
57	634-0070	2	JANTE	FINISH:788-0499/674/0662	
57A	634-0069	2	JANTE 8.0 x 5.38 x 750 ID	634-0069-0662	
58	734-0255	1	VALVE:PNEU	TR 412-P / 32.6mm / 934-0255	
59	710-0627	1	VIS HEX. 5/16-24:.750 GR5:LOCK	FINISH:MTD STD 701-01000	
61	732-0722	1	CROCHET DE RESSORT	732-0722	
62	711-0768	1	GUIDE DE COURROIE	711-0768	
63	736-0275	1	RONDELLE	FINISH:MTD STD 701-01000	
64	710-0428	1	VIS HEXAGONALE	FINISH:701-01000	
65	732-0568	1	RESSORT DE TRACTION	.50 OD X 2.54 LG	
66	732-0384	1	RESSORT DE TRACTION	FINISH:SIEHE ZG.	
67	16554A	1	SUPPORT VARIATEUR	16554A-0637 / 16554A-Z	
67A	16352A	1	LEVIER POUR VARIATEUR	16352A-0637	seulement pour 30" plateau de coupe
68	741-0419	1	SUPPORT DE BRIDE / DOUILLE	741-0419	
69	714-0111	1	GOUILLE FENDUE 3/32:1.0"	FINISH:MTD SPEC-100015	
70	748-0234	1	RONDELLE EPAULEE	FINISH:ROSTPREVENTION	
71	747-0530A	1	TRINGLE	747-0530A	
72	741-0405	1	ENTRETOISE	.56 ID x 1.25 OD x.06/941-0405	
73	720-0232	1	BOUTON DE LEVIER MANUEL	FINISH:KUNSTSTOFF SCHWARZ	
74	756-0437	1	POULIE TENDEUR PLATE METAL	756-0437 / 956-0437	
75	656-0005	1	POULIE	656-0005	seulement pour 18" roues ou 46" plateau de coupe

Position	Numéro de pièce	#	Appellation I	Appellation II	Remarque
75A	656-0004	1	POULIE	656-0004	seulement pour 20" roues sans 46" plateau de coupe
76	736-0427	1	RONDELLE	FINISH:MTD STD 701-01001	
77	712-3035	1	ÜCROU HEXAGONAL	FINISH:STD 701-01000 912-3035	
78	710-0539	1	VIS	STD FINISH:701-01000	
79	754-0370	1	COURROIE MOTEUR/VARIATEUR	754-0370/954-0370	
80	716-0114	1	CIRCLIPS	716-0114	
81	736-0355	1	RONDELLE	FINISH:701-01001	
82	717-0800A	1	POULIE VARIATEUR DE VITESSE	917-0800A NADELLAGER 741-0404	
83	711-1000	1	GUIDE COURROIE 25 X 3.0	911-1000	
84	16354B	1	SUPPORT POULIE	16354B-0637	
85	732-0525	1	RESSORT DE RAPPEL LEVIER	FINISH:PRE-GALVANIZED	
86	17668	1	SUPPORT D'AXE DROIT	17668-0637	
86A	17669	1	SUPPORT D'AXE GAUCHE	17669-0637	
88	725-1426	1	RELAIS DE DEMARRAGE SOLENOID	725-1426 Mutter 712-0271	
89	17630	1	ÜQUERRE DE FIXATION	17630-0637 RB 17630A-0637	
90	736-0414	1	RONDELLE TÜFLON	FINISH:WEISS: 936-0414	
91	750-0957	1	ENTRETOISE	950-0957	
93	725-1657A	1	SECURITE D'EMBRAYAGE	Sich.Mähwerk+Kuppl. GRAU	
94	738-0755	1	AXE	738-0755/938-0755	
96	748-0334	1	ENTRETOISE	FINISH:GEÖLT	seulement pour 18" roues ou 46" plateau de coupe
97	736-0105	1	RONDELLE CONIQUE	FINISH:MTD SPEC-100016	
98	738-0569	1	AXE DE VARIATEUR	738-0569	

Position	Numéro de pièce	#	Appellation I	Appellation II	Remarque
99	736-0331	1	RONDELLE CONIQUE	FINISH:MTD SPEC-100016	
100	736-0256	1	RONDELLE .635ID X 930 OD X.03	736-0256	
101	714-0470	1	EPINGLE EX AF-43010	FINISH:SPEC-100015 470 32 32	
102	710-0604	1	VIS HEX.TT:5/16-18:0.62	FINISH:MTD SPEC-701-01006	
103	734-1615	1	ENJOLIVEUR ARR. GRIS	734-1615	
103A	734-1614	1	ENJOLIVEUR ARR. BEIGE	734-1614	
103B	734-1788	1	ENJOLIVEUR ARRIERE JAUNE	734-1788 (CLIP 727-0425A)	
106	710-0323	1	VIS	FINISH:701-01000	
107	17860	1	SUPPORT PEDALE	17860-0637	
108	714-0470	1	EPINGLE EX AF-43010	FINISH:SPEC-100015 470 32 32	
109	711-0198	1	FUSEAU D'UCROU	FINISH:MTD SPEC 701-01000	
110	710-0376	1	VIS HEX.:5/16-18:1.00:GR5:STD	FINISH:MTD STD 701-01000	
111	710-0195	1	VIS HEXAGONALE	FINISH:701-01000	
112	736-0270	1	RONDELLE GROWER	FINISH:MTD SPEC 701-01001	
113	17707	1	LEVIER	17707	
115	736-0140	1	RONDELLE .385 ID X .62 OD	FINISH:701-01000 or 101616	
116	741-0404	1	ROULEMENT A AIGUILLE VARIATEUR	741-0404/941-0404	
117	727-0425A	1	CLIP ENJOLIVEUR		
118	736-0607	1	RONDELLE	FINISH:MTD STD 701-01001	
119	710-0650	1	VIS HEX.:TT:5/16-18:0.875	FINISH:MTD SPEC-701-01002	
120	17840	1	SUPPORT	FINISH:17840-0637	
121	734-0448	2	PNEU 18*950*8	734-0448-0901	
121A	734-0294	2	PNEU 18*650 *8	734-0294-0901/902	
121B	734-1596	2	PNEU 20 X 8.00.8 ST	BLOCK TURF PRO: RND SHL	profile arrondi
121C	734-1730	2	PNEU 20X800	734-1730-0902, Profil:ST50	Pneus profile plat

RMS 13-96 > [135N674F628 \(1995\)](#) >
[Entraînement de roulement, Poulie moteur, Pedale, Roues arrière](#)

ZWISZYLINDER UND OHV-MOTOR
TWIN CYLINDER AND OHV-ENGINE
CYLINDRE DOUBLE ET MOTEUR OHV

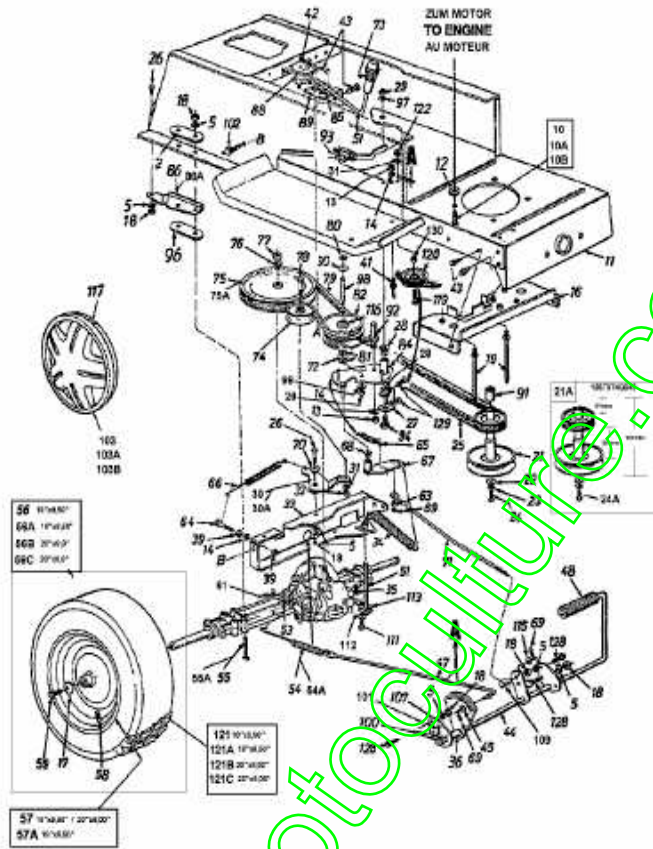

Position	Numéro de pièce	#	Appellation I	Appellation II	Remarque
2	17840	1	SUPPORT	FINISH:17840-0637	
5	736-0119	1	RONDELLE	FINISH:MTD STD 701-01001	
10	710-0502A	1	VIS HEX. 3/8-16:1.250 LG.	SELBSTSCHN. SPEC / 701-01002	seulement pour cylindre double
10A	710-1007	1	VIS HEX.TTSEMS3/8-16:1,500	FINISH:STD 701-01002 or 101616	seulement pour O.H.V
10B	710-1035	1	VIS HEX.TTSEMS3/8-16:2.500HXLW	FINISH:MTD SPEC 701-01002	seulement pour moteur Vanguard
11	683-0065	1	CHASSIS BAS COMPL	683-0065-0637	
13	712-0287	1	ÛCROU HEXAGONAL 1/4-20:GR2	FINISH:701-01000 / 912-0287	
14	736-0329	1	RONDELLE GROWER	FINISH:701-01001 24.8195.16	
16	17358D	1	PROTECTION COURROIE	17358D-0637	
17	736-0242	1	RONDELLE CONIQUE.340X.872X.060	FINISH:MTD STD 701-01001	
18	712-0267	1	ÛCROU HEXAGONAL	FINISH:MTD STD 701-01000	
19	711-0986	1	PROTEGE COURROIE	711-0986 / 911-0986	
21	756-0982	1	POULIE	756-0982	
21A	756-0530	1	POULIE	756-0530	
22	736-0322	1	RONDELLE .450 X 1.250 X .164	FINISH:701-01001 936-0322	
23	736-0171	1	RONDELLE GROWER	FINISH:MTD STD 701-01001	
24	710-0757	1	VIS	FINISH:701-01000 910-0757	
24A	710-3157	1	VIS	710-3157	
25	754-0280	1	COURROIE MOTEUR/VARIATEUR	754-0280 / 954-0280	
26	710-0118	1	VIS	FINISH:PHOS & OIL	
27	17963	1	SUPPORT ARBRE	17963	
28	741-0591	1	BAGUE	FINISH:NATUR 941-0591	
29	712-0241	1	ÛCROU HEX.: 3/8-24:GR5	FINISH:MTD STD 701-01000	
30	17643	1	SUPPORT	17643-0637	

Position	Numéro de pièce	#	Appellation I	Appellation II	Remarque
30A	17694	1	SUPPORT	FINISH:SIEHE ZG.	
31	736-0169	1	BAGUE ÜLASTIQUE	FINISH:MTD SPEC-100016	
32	712-0241	1	ÜCROU HEX.: 3/8-24:GR5	FINISH:MTD STD 701-01000	
33	17629A	1	SUPPORT TRANSMISSION	17629A-0637	
34	732-0556	1	RESSORT EX 732-0436	FINISH:MTD STD 701-01006	
35	714-0149B	1	GOUPILLE FENDUE 1/2"	714-0149B	
36	750-0802	1	ENTRETOISE / .640IDX.760DX2.63	FINISH:KUNSTSTOFF SCHWARZ	
39	712-0138	1	ÜCROU HEX. 1/4-28"	712-0138	
40	710-0776A	1	VIS	710-0776A	
41	711-0747	1	GUIDE COURROIE	FINISH:SIEHE ZG.	
42	736-0222	1	RONDELLE	FINISH:MTD STD 701-01001	
43	710-0599	1	VIS i SIX PANS CREUX	MTD SPEC-701-01002 or 101617	
44	17715B	1	PEDALE EMBRAYAGE + FREINS COM	17715B-0637	
45	736-0264	1	RONDELLE: .330 x.630 x.0635	FINISH:701-01000 936-0264	
47	17686A	1	TIGES DE FREIN	17686A	
48	735-0196	1	GARNITURE PEDALE 4,6 LG	FINISH:SCHWARZ	
51	17705	1	LEVIER	17705	
53	732-0264	1	RESSORT	FINISH:SPEC-701-01006 932-0264	
54	732-0413	1	RESSORT DE TRACTION	FINISH:PHOS & OIL	seulement pour 20" roues sans 46" plateau de coupe
54A	732-0642	1	RESSORT	732-0642/932-0642	seulement pour 18" roues ou 46" plateau de coupe
55	710-0189	1	VIS HEX.:5/16-18x3.00:GR5:STD	701-01000 or 101616 910-0189	seulement pour 20" roues sans 46" plateau de coupe

Position	Numéro de pièce	#	Appellation I	Appellation II	Remarque
55A	710-1068	1	VIS	710-1068	seulement pour 18" roues ou 46" plateau de coupe
56	734-0817	2	ROUE COMPL 18X9,50-8 ST ELEC	734-0817662/-674/-WY/-CB	
56A	734-0592	2	ROUE COMPL 18X6.50-8 ST	734-0592662/-G/-674/-Y/-CB/-WY	
56B	734-1675	2	ROUE COMPL 20X8;00-8 ST	734-1675-0911	profile arrondi
56C	634-0104	2	ROUE COMPL 20" x 8" BEIGE	634-0104662/-G/-674/-Y/-CB/-WY	Pneus profile plat
57	634-0070	2	JANTE	FINISH:788-0499/674/0662	
57A	634-0069	2	JANTE 8.0 x 5.38 x 750 ID	634-0069-0662	
58	734-0255	1	VALVE:PNEU	TR 412-P / 32.6mm / 934-0255	
59	710-0627	1	VIS HEX. 5/16-24:.750 GR5:LOCK	FINISH:MTD STD 701-01000	
61	732-0722	1	CROCHET DE RESSORT	732-0722	
63	736-0275	1	RONDELLE	FINISH:MTD STD 701-01000	
64	710-0428	1	VIS HEXAGONALE	FINISH:701-01000	
65	732-0568	1	RESSORT DE TRACTION	.50 OD X 2.54 LG	
66	732-0384	1	RESSORT DE TRACTION	FINISH:SIEHE ZG.	
67	16554A	1	SUPPORT VARIATEUR	16554A-0637 / 16554A-Z	
68	741-0419	1	SUPPORT DE BRIDE / DOUILLE	741-0419	
69	714-0111	1	GOUPILLE FENDUE 3/32:1.0"	FINISH:MTD SPEC-100015	
70	748-0234	1	RONDELLE EPAULEE	FINISH:ROSTPREVENTION	
71	747-0530A	1	TRINGLE	747-0530A	
72	741-0405	1	ENTRETOISE	.56 ID x 1.25 OD x.06/941-0405	
73	720-0232	1	BOUTON DE LEVIER MANUEL	FINISH:KUNSTSTOFF SCHWARZ	
74	756-0437	1	POULIE TENDEUR PLATE METAL	756-0437 / 956-0437	

Position	Numéro de pièce	#	Appellation I	Appellation II	Remarque
75	656-0005	1	POULIE	656-0005	seulement pour 18" roues ou 46" plateau de coupe
75A	656-0004	1	POULIE	656-0004	seulement pour 20" roues sans 46" plateau de coupe
76	736-0427	1	RONDELLE	FINISH:MTD STD 701-01001	
77	712-3035	1	ÜCROU HEXAGONAL	FINISH:STD 701-01000 912-3035	
78	710-0539	1	VIS	STD FINISH:701-01000	
79	754-0370	1	COURROIE MOTEUR/VARIATEUR	754-0370/954-0370	
80	716-0114	1	CIRCLIPS	716-0114	
81	736-0355	1	RONDELLE	FINISH:701-01001	
82	717-0800A	1	POULIE VARIATEUR DE VITESSE	917-0800A NADELLAGER 741-0404	
84	16354B	1	SUPPORT POULIE	16354B-0637	
85	732-0525	1	RESSORT DE RAPPEL LEVIER	FINISH:PRE-GALVANIZED	
86	17668	1	SUPPORT D'AXE DROIT	17668-0637	
86A	17669	1	SUPPORT D'AXE GAUCHE	17669-0637	
88	725-1426	1	RELAIS DE DEMARRAGE SOLENOID	725-1426 Mutter 712-0271	
89	17630	1	ÉQUERRE DE FIXATION	17630-0637 RB 17630A-0637	
90	736-0414	1	RONDELLE TÜFLON	FINISH:WEISS: 936-0414	
91	750-0957	1	ENTRETOISE	950-0957	
92	711-1000	1	GUIDE COURROIE 25 X 3.0	911-1000	
93	725-1657A	1	SECURITE D'EMBRAYAGE	Sich.Mähwerk+Kuppl. GRAU	
94	738-0755	1	AXE	738-0755/938-0755	

Position	Numéro de pièce	#	Appellation I	Appellation II	Remarque
96	748-0334	1	ENTRETOISE	FINISH:GEÖLT	seulement pour 18" roues ou 46" plateau de coupe
97	736-0105	1	RONDELLE CONIQUE	FINISH:MTD SPEC-100016	
98	738-0569	1	AXE DE VARIATEUR	738-0569	
99	736-0331	1	RONDELLE CONIQUE	FINISH:MTD SPEC-100016	
100	736-0256	1	RONDELLE .635ID X 930 OD X.03	736-0256	
101	714-0470	1	EPINGLE EX AF-43010	FINISH:SPEC-100015 470 32 32	
102	710-0604	1	VIS HEX.TT:5/16-18:0.62	FINISH:MTD SPEC-701-01006	
103	734-1615	1	ENJOLIVEUR ARR. GRIS	734-1615	
103A	734-1614	1	ENJOLIVEUR ARR. BEIGE	734-1614	
103B	734-1788	1	ENJOLIVEUR ARRIERE JAUNE	734-1788 (CLIP 727-0425A)	
106	710-0323	1	VIS	FINISH:701-01000	
107	17860	1	SUPPORT PEDALE	17860-0637	
109	711-0198	1	FUSEAU D'UCROU	FINISH:MTD SPEC 701-01000	
111	710-0195	1	VIS HEXAGONALE	FINISH:701-01000	
112	736-0270	1	RONDELLE GROWER	FINISH:MTD SPEC 701-01001	
113	17707	1	LEVIER	17707	
115	736-0140	1	RONDELLE .385 ID X .62 OD	FINISH:701-01000 or 101616	
116	741-0404	1	ROULEMENT A AIGUILLE VARIATEUR	741-0404/941-0404	
117	727-0425A	1	CLIP ENJOLIVEUR		
119	710-0427	1	VIS	710-0427	
120	756-0217	1	POULIE TENDEUR AVEC ROULEMENT	756-0217/956-0217	
121	734-0448	2	PNEU 18*950*8	734-0448-0901	
121A	734-0294	2	PNEU 18*650 *8	734-0294-0901/902	
121B	734-1596	2	PNEU 20 X 8.00.8 ST	BLOCK TURF PRO: RND SHL	profile arrondi

Position	Numéro de pièce	#	Appellation I	Appellation II	Remarque
121C	734-1730	2	PNEU 20X800	734-1730-0902, Profil:ST50	Pneus profile plat
122	712-0798	1	ÛCROU HEXAGONAL	912-0798	
128	710-0650	1	VIS HEX.:TT:5/16-18:0.875	FINISH:MTD SPEC-701-01002	
129	710-0726	1	VIS 5/16-12:0.750:HXINDWS	FINISH:MTD STD 701-01002	
130	736-0280	1	RONDELLE 1.39"	FINISH:MTD STD 701-01001	fsg

www.emc-motoculture.com

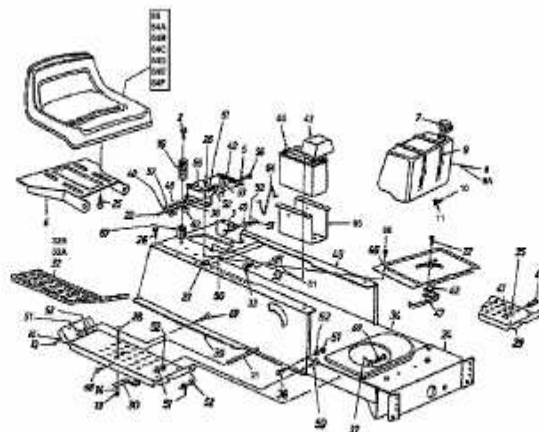

www.emc-motoculture.com

Position	Numéro de pièce	#	Appellation I	Appellation II	Remarque
2	710-1208	1	VIS HEX.TT5/16-18:3.500	FINISH:MTD SPEC-701-01002	
3	738-0155	1	VIS EPAULEE	MTD STD 701-01000 938-0155	
4	738-0145	1	AXE	738-0145	
5	736-0141	1	RONDELLE	FINISH:701-01001	
6	783-0039	1	VOIR 783-0039A	783-0039	
7	751-0603	1	BOUCHON RESERVOIR ESSENCE	FINISH:SCHWARZ	
8	751-0553	1	RESERVOIR 5 L ENV.	FINISH:NATUR SIEHE ZG.	
8A	751-0555	1	RESERVOIR 7 L ENV.	751-0555 1 1/2 GALLON	
9	726-0209	1	COLLIER	FINISH:SCHWARZ	
10	751-0535-15	1	TUYAU / ESSENCE	751-0535 15" LANG	
11	726-0205	1	COLLIER DE SERRAGE DE BOYAU	FINISH:PHOSPHATIERT (GELB)	
13	712-0287	1	ÜCROU HEXAGONAL 1/4-20:GR2	FINISH:701-01000 / 912-0287	
14	736-0329	1	RONDELLE GROWER	FINISH:701-01001 24.8195.16	
16	732-0735	1	RESSORT DE SIEGE SUP GAUCHE	FINISH:PHOS & OIL	
21	738-0526	1	TIGE MARCHEPIED	738-0526	
22	710-0227	1	VIS	FINISH:MTD STD 701-01002	
23	726-0139	1	ÜCROU	726-0139	
24	783-0041	1	VOIR 783-0041A	783-0041A-0637	
25	710-0623	1	VIS PARK. HEX.:TT:3/8-16:0.750	FINISH:MTD SPEC-701-01002	
26	710-0726	1	VIS 5/16-12:0.750:HXINDWS	FINISH:MTD STD 701-01002	
28	710-0134	1	VIS TATE PLATE	FINISH:MTD STD 701-01000	
29	17770A	2	731-08910	17770A	
30	761-0168B	2	FREIN DE LAME	761-0168B / 961-0168B RB D!	
32	731-0909	1	REPOSE-PIED GAUCHE	731-0909	
32A	731-0910	1	REPOSE-PIED DT	731-0910	
32B	723-0422	2	TRITTBRETТАUFLAGE	Antirutschbelag Sandpapier	
33	710-0323	1	VIS	FINISH:701-01000	
34	683-0065	1	CHASSIS BAS COMPL	683-0065-0637	
35	736-0169	1	BAGUE ÜLASTIQUE	FINISH:MTD SPEC-100016	
36	726-0278	1	PLAQUE D'ISOLATION	FINISH:NATUR ODER SCHWARZ	

Position	Numéro de pièce	#	Appellation I	Appellation II	Remarque
37	736-0264	1	RONDELLE: .330 x.630 x.0635	FINISH:701-01000 936-0264	
38	710-0118	1	VIS	FINISH:PHOS & OIL	
39	783-0042	1	RAHMENTEIL RECHTS	783-0042	
41	712-0798	1	ÜCROU HEXAGONAL	912-0798	
42	732-0581B	1	RESSORT DE TRACTION	732-0581B	
43	731-1200	1	COUVERCLE DE BATTERIE	731-1200	
44	725-1635	1	BATTERIE 12V /20AH	C50N18L-A-CX	
45	783-0043	1	CHASSIS GAUCHE	783-0043-0638	
47	725-1643	1	CONTACTEUR SECURITE	LANG:FINISH: SIEHE ZG.	
48	726-0279	1	PLAQUE D'ISOLATION	FINISH:NATUR ODER SCHWARZ	
49	17951	1	SUPPORT FIXATION GAUCHE	17951-0637	
50	17953	1	PLAQUE	17953	
51	712-0267	1	ÜCROU HEXAGONAL	FINISH:MTD STD 701-01000	
52	736-0119	1	RONDELLE	FINISH:MTD STD 701-01001	
53	17239A	1	LEVIER / CONTACT	17239A	
54	757-0363A	1	SIEGE INFERIEUR NOIR		
54A	757-0350	1	SIEGE -SUPERIEUR NOIR	mit Drainage	
54B	757-0364A	1	SIEGE JAUNE N.M V380	957-0364A	
54C	757-0365	1	SIEGE JAUNE YARDMAN	757-0365	
54D	757-0372	1	SIEGE JAUNE SUPERIEUR	757-0372	
54E	757-0360A	1	SIEGE DOSSIER MOYEN		
54F	757-0348A	1	SIEGE SUPERIEUR NOIR	757-0348A	
55	17950	1	ÜQUERRE DE FIXATION DROITE	17950-0637	
56	738-0296	1	AXE EPAULE	FINISH:701-01000	
57	725-1303	1	RESSORT DE S®RETÜ SIEGE	SI.-SCHALTER SITZ:GELBVERZINKT	
59	710-0650	1	VIS HEX.:TT:5/16-18:0.875	FINISH:MTD SPEC-701-01002	
62	726-0320	1	PLAQUE D'ISOLATION	FINISH:NATUR ODER SCHWARZ	
63	725-1439	1	RESSORT S®RETÜ DE SIEGE	SI.-SCHALTER SITZ:GELBVERZINKT	

Position	Numéro de la pièce	#	Appellation I	Appellation II	Remarque
64	732-0674	1	ATTACHE BATTERIE	732-0674	seulement pour cylindre single
65	17952	1	BOÎTIER DE BATTERIE	17952	
66	710-0351	1	VIS	MTD SPEC-100016	
67	748-0347	1	SUPPORT RESSORT	748-0347	
68	710-1221	1	VIS 5/16-18x.75"	710-1221	
69	710-0118	1	VIS	FINISH:PHOS & OIL	fsg

www.emc-motoculture.com

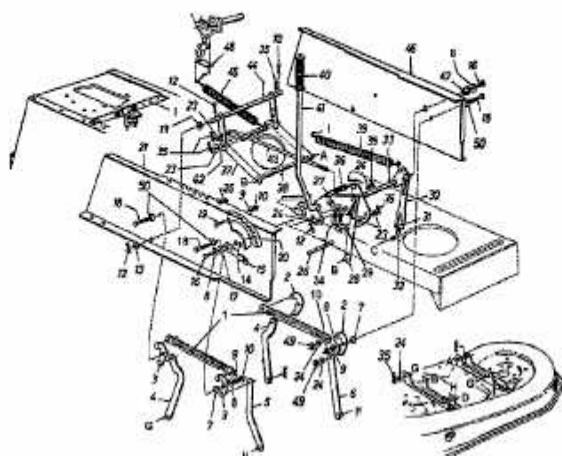

www.emc-motoculture.com

Position	Numéro de pièce	#	Appellation I	Appellation II	Remarque
1	783-0103	1	LEVIER	783-0103-0637	
2	683-0029A	1	PIVOT GAUCHE	683-0029A/983-0029A	
3	683-0028A	1	PIVOT DROIT	983-0028A-0637	
4	17710	1	BRAS AR	17710-0637 / 97710-0637	
5	14800A	1	ÜCLISSE DE SUSPENSION	14800A-0637	
6	14804A	1	ÜCLISSE DE SUSPENSION	14804A/94804A-0637	
7	748-0331	1	ENTRETOISE	FINISH:GEÖLT	
8	736-0264	1	RONDELLE: .330 x.630 x.0635	FINISH:701-01000 936-0264	
9	736-0119	1	RONDELLE	FINISH:MTD STD 701-01001	
10	712-0267	1	ÜCROU HEXAGONAL	FINISH:MTD STD 701-01000	
12	714-0470	1	EPINGLE EX AF-43010	FINISH:SPEC-100015 470 32 32	
13	736-0256	1	RONDELLE .635ID X 930 OD X.03	736-0256	
14	683-0003	1	LEVIER D'AJUSTAGE D'HAUTEUR	FUER SCHNITTHOEHE	
15	08540	1	BOUTON		
16	710-0604	1	VIS HEX.TT:5/16-18:0.62	FINISH:MTD SPEC-701-01006	
17	748-0176	1	PALIER DE BRIDE	FINISH:WIE HERGESTELLT	
18	710-1238	1	VIS HHWSH:5/16-18:.875:GR5:STD	FINISH:MTD STD 701-01000	
19	710-0118	1	VIS	FINISH:PHOS & OIL	
20	17730	1	LEVIER NIVEAU DE COUPE	17730	
21	783-0042	1	RAHMENTEIL RECHTS	783-0042	
23	736-0267	1	RONDELLE PL.:.385 x.87 x.06:HT	701-01001 OPTIONAL SPEC-100015	
24	736-0160	1	RONDELLE 536 IDX.930ODX.050	FINISH:MTD SPEC-100015	
25	726-0272	1	COLLIER	FINISH:VERZINKT	
26	738-0526	1	TIGE MARCHEPIED	738-0526	
27	710-3007	1	VIS HEXAGONALE	FINISH:SPEC-701-01002 910-3007	
28	14802A	1	CHANDELLE DE PLATEAU	14802A-0637	
29	711-0723A	1	TOURILLON	711-0723A/911-0723A	
30	17712	1	ECLISSE / AJUSTEMENT	17712-0637	
31	712-3066	1	ÜCROU HEXAGONAL 1/2-20 GR5	FINISH:MTD STD 701-01000	

Position	Numéro de pièce	#	Appellation I	Appellation II	Remarque
32	711-0841	1	TIGE 500-20	711-0841	
33	17637A	1	ARBRE DE RELEVAGE	17637A/97637A-0637	
34	725-1657A	1	SECURITE D'EMBAYAGE	Sich.Mähwerk+Kuppl. GRAU	
35	714-0145	1	GOUPILLE	FINISH:PHOS & OIL	
36	732-0637	1	RESSORT PEDALIER	732-0637	
37	17636B	1	STABILISATEUR	17636B-0637	
38	738-0670	1	AXE	738-0670	
39	732-0638	1	RESSORT	FINISH:PHOS & OIL 32cm	
40	720-0233	1	POIGNEE	720-0233	
41	17675	1	LEVIER	17675	
42	738-0669	1	AXE	738-0669	
43	747-0598	1	TRINGLERIE	747-0598	
44	97624	1	STABILISATEUR EX 17624	97624-0637 *	
45	732-0556	1	RESSORT EX 732-0436	FINISH:MTD STD 701-01906	
46	783-0043	1	CHASSIS GAUCHE	783-0043-0638	
47	741-0487A	1	PALIER DE BRIDE	741-0487A (BR.748-0184)	
48	17128A	1	SUPPORT EX.17128	17128A-0637	
49	716-0104	1	CIRCLIPS:.500 DIA ARBRE	FINISH:ÖL BENETZT	
50	736-0425	1	RESSORT a DISQ.:.325x.930x.045	FINISH:701-01001	fsg

www.emc-motoculture.com

Deck "F"

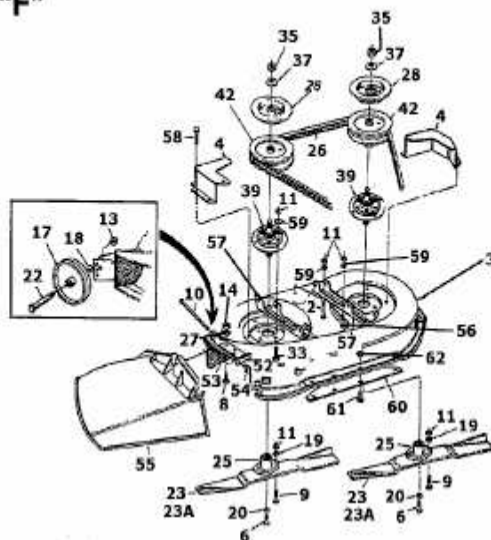

www.emc-motoculture.com

Position	Numéro de pièce	#	Appellation I	Appellation II	Remarque
1	750-0776	1	ENTRETOISE .33ID X .88OD X .51	750-0776	
2	710-0672	1	VIS HEX. 5/16-24:1.25:GR5:STD	FINISH:701-01000 910-0672	
3	753-0694	1	PLATEAU DE COUPAGE COMPL 38"/	753-0694-0637	
4	17967	1	PROTEGE COURROIE	17967-0637	
6	710-0152	1	VIS HCCS:3/8-24:1.00:GR5:STD	910-0152	
8	710-0258	1	VIS	710-0258	
9	710-0888	1	VIS HEXAGONAL	5/16-24X1.00	
10	711-0792	1	GOUJON	MTD SPEC 701-01000 911-0792	
11	712-0123	1	ÜCROU HEXAGONAL	FINISH:701-01000	
13	712-0181	1	ÜCROU	FINISH:MTD SPEC-100015	
14	712-0287	1	ÜCROU HEXAGONAL 1/4-20:GR2	FINISH:701-01000 / 912-0287	
17	734-0973	1	ROULETTE DE PLATEAU	FINISH:KUNSTSTOFF SCHWARZ	
18	736-0105	1	RONDELLE CONIQUE	FINISH:MTD SPEC-100016	
19	736-0119	1	RONDELLE	FINISH:MTD STD 701-01001	
20	736-0217	1	RONDELLE GROWER	FINISH:701-01001	
22	738-0373	1	VIS CRAULE .496X1.525:3/8-16	FINISH:MTD STD 701-01000	
23	742-0473A	2	LAME COUPE 96CM LATERALE < 96	742-0473A/942-0473A	
23A	742-0504	2	LAME EXTRA-SFF COUPE 96CM 3T	742-0504/942-0504	
25	748-0300	2	SUPPORT DE LAME 3T AUTOPORTEES	748-0300	
26	754-0427	1	COURROIE DE LAME COUPE 96CM	754-0427/954-0427	
27	736-0270	1	RONDELLE GROWER	FINISH:MTD SPEC 701-01001	
28	09322	1	DISQUE DE FREIN	VERZINKT	
33	710-0157	1	VIS HEX.:5/16-24:.75 GR5 STD	FINISH:701-01000	
35	712-0318	1	ECROU	712-0318	
37	736-0158	1	RONDELLE GROWER	FINISH:MTD STD 701-01001	

Position	Numéro de pièce	#	Appellation I	Appellation II	Remarque
39	917-0906A	1	PALIER COMPLET 96/107 CM	917-0906A	
42	756-0556	1	POULIE	756-0556 *	
52	703-1693	1	PLAQUE DE RACCORDEMENT	703-1693	
53	732-0602	1	RESSORT	732-0602 / 932-0602	
54	726-0106	1	COUVERCLE 1/4 "	FINISH:MTD STD 701-01000	
55	731-1032	1	CLAPET D'ÜJECTION	731-1032	
56	710-0157	1	VIS HEX.:5/16-24:.75 GR5 STD	FINISH:701-01000	
57	17493A	1	SUPPORT	17493A-0637	
58	710-0599	1	VIS i SIX PANS CREUX	MTD SPEC-701-01002 or 101617	
59	736-0242	1	RONDELLE CONIQUE.340X.872X.060	FINISH:MTD STD 701-01001	
60	17863	1	PLAQUE	17863-0637	
61	710-0167	1	VIS 1/4-20x.50" GR 1	FINISH:701-01000	
62	712-0271	1	ECROU 1/4-20"+ DISQUE DENTÜ	FINISH:MTD STD 701-010015	fsg

www.emc-motocycles.com

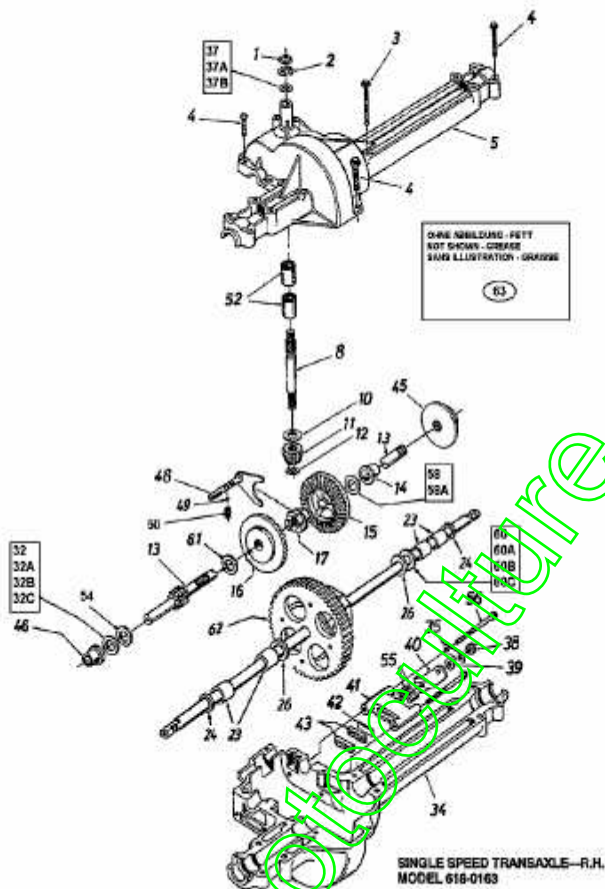

www.emc-motoculture.com

Position	Numéro de pièce	#	Appellation I	Appellation II	Remarque
1	732-0614	1	CIRCLIPS	FINISH:ZINC PHOSPHATE	
2	716-0231	1	CIRCLIPS	FINISH:PHOS & OIL/916-0231	
4	710-1026	1	VIS HEX:TT:1/4-20:1.750	FINISH:MTD-SPEC-100016	
5	719-0314	1	CARTER SUPÛRIEUR	719-0314	
8	711-0861	1	AXE	711-0861	
10	736-0335	1	RONDELLE 1 5/8XA1.25"X.06	FINISH:SIEHE ZG.	
11	717-0633	1	PIGNON 14 DENTS	717-0633/917-0633	
12	716-0171	1	CLIPS	FINISH:MFG.STANDARD 916-0171	
13	711-1003	1	AXE	711-1003/911-1003	
14	741-0336	1	BAGUE	FINISH:SIEHE ZG. 941-0336	
15	717-1362	1	PIGNON CONIQUE 42 DENTS PT US	717-1362 / 917-1362 *	
16	717-1363	1	PIGNON CONIQUE 42 DENTS GR US	717-1363/917-1363 *	
17	718-0228	1	CRABOT	718-0228	
21	710-0862A	1	VIS	710-0862A	
23	741-0340	1	DOUILLE	ÖLIMRÄGNIERT EXXON 941-0340	
24	721-0338	1	JOINT	.75 x 1.00 x .125:FINISH STD	
26	736-0445	1	RONDELLE	FINISH:701-01001	
32	736-0495	1	RONDELLE	FINISH:SIEHE ZG. 936-0495	
32A	736-0336	1	RONDELLE 5/8X1.00X.030	ZINC SIEHE ZG.	
32B	736-0494	1	RONDELLE	FINISH:ZINC SIEHE ZG.	
32C	736-0337	1	RONDELLE 5/8 IDX1.0 ODX.040	MTD STD 701-01001 936-0337	
34	719-0313	1	CARTER INFÛRIEUR	719-0313/719-0313A	
35	718-0150	1	LANG. DE SUPP.: ANTI ROTATION	FINISH:GELB VERZINKT	
37	736-0349	1	RONDELLE 5/8 IDX10 OD X .020	FINISH:SIEHE ZG.	
37A	736-0336	1	RONDELLE 5/8X1.00X.030	ZINC SIEHE ZG.	
37B	736-0337	1	RONDELLE 5/8 IDX1.0 ODX.040	MTD STD 701-01001 936-0337	
38	712-0273	1	ÛCROU HEXAGONAL 5/16-24"	FINISH:MTD STD 701-01000	
39	736-0371	1	RONDELLE 1.344XA .875"	FINISH:701-01001	

Position	Numéro de pièce	#	Appellation I	Appellation II	Remarque
40	717-0700	1	LEVIER DE FREIN, i DROITE	717-0700	
41	761-0198	1	CARTER DE FREIN	FINISH:NONE	
42	717-0682	1	INSERT DE FREIN	FINISH:NONE 917-0682	
43	717-0678	1	PLAQUETTE DE FREIN	FINISH:	
45	761-0202	1	DISQUE DE FREIN	FINISH:ÖL UND FETTFREI	
46	741-0337	1	BAGUE	941-0337	
48	611-0011	1	FOURCHETTE	FINISH: 911-0011	
49	741-0862	1	BILLE	FINISH: SIEHE ZG.	
50	732-0863	1	RESSORT i PRESSION 225X.50"	FINISH: PHOS & OIL 932-0863	
52	741-0335	1	ROULEMENT 1,5/8X1/2" LG	FINISH:SIEHE ZG. 941-0335	
54	736-0349	1	RONDELLE 5/8 IDX10 OD X .020	FINISH:SIEHE ZG.	
55	741-0343	1	GOUJON DE PRESSION 5/16"	FINISH:SIEHE ZG. 941-0343	
56	710-1206	1	VIS HEX. TT:1/4-20:2.375	FINISH:MTD SPEC-701-01002	
58	736-0349	1	RONDELLE 5/8 IDX10 OD X .020	FINISH:SIEHE ZG.	
58A	736-0495	1	RONDELLE	FINISH:SIEHE ZG. 936-0495	
60	736-0492	1	RONDELLE 76X1.5X.010	FINISH:VERZINKT: 936-0492	
60A	736-0493	1	RONDELLE 76X1.5X.020	FINISH:BLAU VERZINKT 936-0493	
60B	736-0351	1	RONDELLE .75x1.50"	FINISH:BLAU VERZINKT 936-0351	
60C	736-0445	1	RONDELLE	FINISH:701-01001	
61	736-0519	1	RONDELLE	736-0519/936-0519	
62	618-0162	1	DIFFERENTIEL COMPL	618-0162 / 918-0162	
63	737-0148	1	GRAISSE		fsg

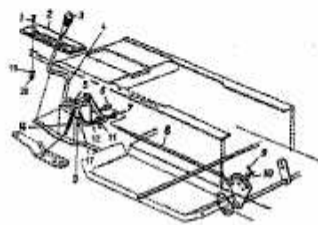

www.emc-motoculture.com

Position	Numéro de pièce	#	Appellation I	Appellation II	Remarque
1	710-0924	1	VIS EN TÊTE PLATE 1/4-20X;75"	FINISH:MTD STD 701-01000	
2	17469	1	SELECTEUR 7 VITESSES	17469-0637	
3	720-0218	1	POIGNEE	720-0218	
4	16192A	1	LEVIER VITESSE	16192A	
5	736-0192	1	RONDELLE .531 X 93 X .090	FINISH:701-01000	
6	711-0198	1	FUSEAU D'ÛCROU	FINISH:MTD SPEC 701-01000	
7	738-0155	1	VIS EPAULEE	MTD STD 701-01000 938-0155	
8	747-0503A	1	TRINGLE	747-0503A	
9	714-0111	1	GOUPILLE FENDUE 3/32:1.0"	FINISH:MTD SPEC- 100015	
10	736-0226	1	RONDELLE	FINISH:MTD STD 701-01000	
11	736-0119	1	RONDELLE	FINISH:MTD STD 701-01001	
12	712-0267	1	ÛCROU HEXAGONAL	FINISH:MTD STD 701-01000	
14	732-0303	1	RESSORT DE TRACTION	FINISH:PHOS & OIL	
17	736-0140	1	RONDELLE .385 ID X .62 OD	FINISH:701-01000 or 101616	
19	736-0329	1	RONDELLE GROWER	FINISH:701-01001 24.8195.16	
20	712-0287	1	ÛCROU HEXAGONAL 1/4-20:GR2	FINISH:701-01000 / 912-0287	fsg

www.emcmotoculture.com

Deck "F"

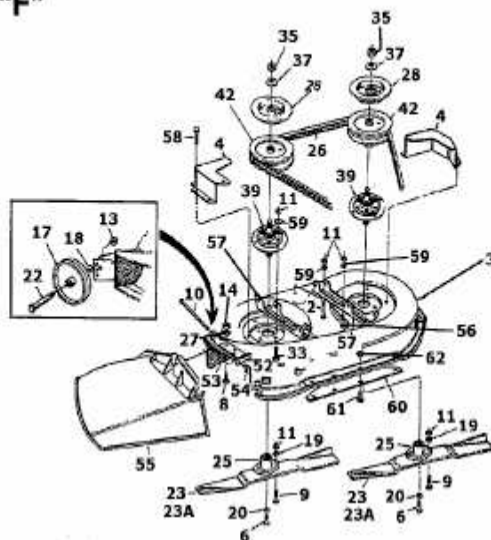

www.emc-motoculture.com

Position	Numéro de pièce	#	Appellation I	Appellation II	Remarque
1	750-0776	1	ENTRETOISE .33ID X .88OD X .51	750-0776	
2	710-0672	1	VIS HEX. 5/16-24:1.25:GR5:STD	FINISH:701-01000 910-0672	
3	753-0694	1	PLATEAU DE COUPAGE COMPL 38"/	753-0694-0637	
4	17967	1	PROTEGE COURROIE	17967-0637	
6	710-0152	1	VIS HCCS:3/8-24:1.00:GR5:STD	910-0152	
8	710-0258	1	VIS	710-0258	
9	710-0888	1	VIS HEXAGONAL	5/16-24X1.00	
10	711-0792	1	GOUJON	MTD SPEC 701-01000 911-0792	
11	712-0123	1	ÜCROU HEXAGONAL	FINISH:701-01000	
13	712-0181	1	ÜCROU	FINISH:MTD SPEC-100015	
14	712-0287	1	ÜCROU HEXAGONAL 1/4-20:GR2	FINISH:701-01000 / 912-0287	
17	734-0973	1	ROULETTE DE PLATEAU	FINISH:KUNSTSTOFF SCHWARZ	
18	736-0105	1	RONDELLE CONIQUE	FINISH:MTD SPEC-100016	
19	736-0119	1	RONDELLE	FINISH:MTD STD 701-01001	
20	736-0217	1	RONDELLE GROWER	FINISH:701-01001	
22	738-0373	1	VIS CRAULE .496X1.525:3/8-16	FINISH:MTD STD 701-01000	
23	742-0473A	2	LAME COUPE 96CM LATERALE < 96	742-0473A/942-0473A	
23A	742-0504	2	LAME EXTRA-SFF COUPE 96CM 3T	742-0504/942-0504	
25	748-0300	2	SUPPORT DE LAME 3T AUTOPORTEES	748-0300	
26	754-0427	1	COURROIE DE LAME COUPE 96CM	754-0427/954-0427	
27	736-0270	1	RONDELLE GROWER	FINISH:MTD SPEC 701-01001	
28	09322	1	DISQUE DE FREIN	VERZINKT	
33	710-0157	1	VIS HEX.:5/16-24:.75 GR5 STD	FINISH:701-01000	
35	712-0318	1	ECROU	712-0318	
37	736-0158	1	RONDELLE GROWER	FINISH:MTD STD 701-01001	

Position	Numéro de pièce	#	Appellation I	Appellation II	Remarque
39	917-0906A	1	PALIER COMPLET 96/107 CM	917-0906A	
42	756-0556	1	POULIE	756-0556 *	
52	703-1693	1	PLAQUE DE RACCORDEMENT	703-1693	
53	732-0602	1	RESSORT	732-0602 / 932-0602	
54	726-0106	1	COUVERCLE 1/4 "	FINISH:MTD STD 701-01000	
55	731-1032	1	CLAPET D'ÜJECTION	731-1032	
56	710-0157	1	VIS HEX.:5/16-24:.75 GR5 STD	FINISH:701-01000	
57	17493A	1	SUPPORT	17493A-0637	
58	710-0599	1	VIS i SIX PANS CREUX	MTD SPEC-701-01002 or 101617	
59	736-0242	1	RONDELLE CONIQUE.340X.872X.060	FINISH:MTD STD 701-01001	
60	17863	1	PLAQUE	17863-0637	
61	710-0167	1	VIS 1/4-20x.50" GR 1	FINISH:701-01000	
62	712-0271	1	ECROU 1/4-20"+ DISQUE DENTÜ	FINISH:MTD STD 701-010015	fsg

www.emc-motocycles.com

717-0906 / 717-0906A

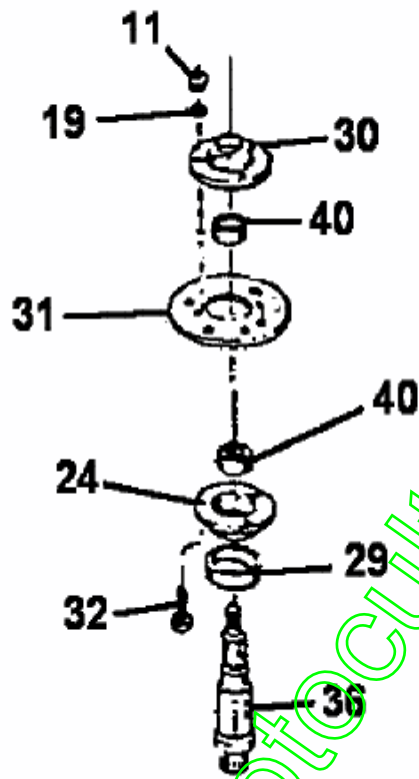

Fig

A1992-400-01

www.emc-motoculture.com

Position	Numéro de lapièce	#	Appellation I	Appellation II	Remarque
11	712-0123	3	ÜCROU HEXAGONAL	FINISH:701-01000	
19	736-0119	3	RONDELLE	FINISH:MTD STD 701-01001	
24	08253B	1	COUELLE INFERIEURE	FINISH:VERZINKT SIEHE ZG.	
29	13703	1	RONDELLE	FINISH:PHOSPHATE & OIL	
30	15296A	1	COUELLE SUPERIEURE	FINISH:GELBVERZINKT	
31	16603A	1	CROCHET	FINISH:LACKIERT	
32	710-0157	3	VIS HEX.:5/16-24:.75 GR5 STD	FINISH:701-01000	
36	738-0707A	1	AXE PALIERS 717- 0900A/717-0906		
40	741-0919	2	ROULEMENT ; BILLES	FINISH:SIEHE SPEC.	fsg

www.emc-motoculture.com

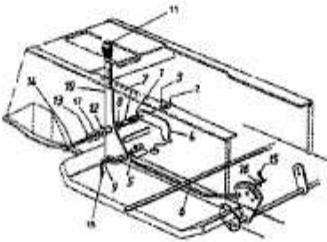

www.emc-motoculture.com

Position	Numéro de pièce	#	Appellation I	Appellation II	Remarque
1	732-0645	1	RESSORT 50 ID .750 DX 100	732-0645	
2	712-0267	1	ÛCROU HEXAGONAL	FINISH:MTD STD 701-01000	
3	736-0119	1	RONDELLE	FINISH:MTD STD 701-01001	
4	17956	1	SUPPORT	17956	
5	711-0198	1	FUSEAU D'ÛCROU	FINISH:MTD SPEC 701-01000	
6	747-0787	1	TIGE	747-0787	
7	750-0662	1	ENTRETOISE .3125 ID x 50 x1.5	750-0662	
8	736-0253	1	RONDELLE	FINISH:MTD STD 701-01001	
9	736-0300	1	RONDELLE	FINISH:MTD SPEC-100015	
10	17888A	1	LEVIER	17888A	
11	720-0232	1	BOUTON DE LEVIER MANUEL	FINISH:KUNSTSTOFF SCHWARZ	
12	750-0913	1	ENTRETOISE 312 X 1.460 LG	750-0913	
13	736-0242	1	RONDELLE CONIQUE.340X.872X.060	FINISH:MTD STD 701-01001	
14	710-3056	1	VIS	FINISH:MTD STD 701-01000	
15	714-0111	1	GOUPILLE FENDUE 3/32:1.0"	FINISH:MTD SPEC-100015	
16	736-0226	1	RONDELLE	FINISH:MTD STD 701-01000	
17	736-0418A	1	RONDELLE	736-0418A	fsg

Single Cylinder

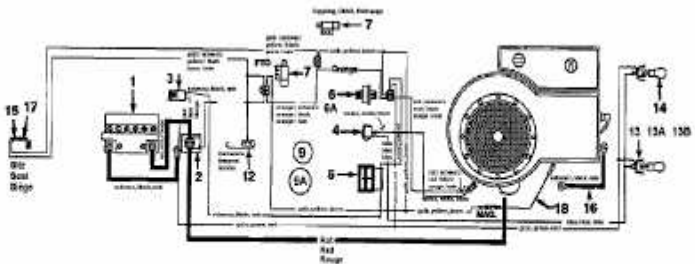

www.emc-motoculture.com

Position	Numéro de pièce	#	Appellation I	Appellation II	Remarque
1	725-1635	1	BATTERIE 12V /20AH	C50N18L-A-CX	
2	725-1426	1	RELAIS DE DEMARRAGE SOLENOID	725-1426 Mutter 712-0271	
3	725-1625	1	FUSIBLE	725-1625	
4	725-0634	1	COMMUTATEUR	FINISH: SCHWARZ	
5	725-0925	1	AMPÈREMÈTRE ANGULEUX	725-0925	
6	725-0267	1	CONTACTEUR A CLE 5 FICHES	B.6PIN ERS.629-0234) 925-0267	
6A	725-0201	1	CLÜ DE CONTACT	FINISH:VERNICKELT 079.12.707	
7	725-1657	1	VOIR 725-1657A	725-1657	
8	725-1643	1	CONTACTEUR SECURITE	LANG:FINISH: SIEHE ZG.	
9	629-0201	1	FUSEAU	629-0201	sans ampermetre
9A	629-0203	1	FAISCEAU	629-0203	avec ampermetre
12	725-1643	1	CONTACTEUR SECURITE	LANG:FINISH: SIEHE ZG.	
13	725-1649	2	DOUILLE DE LAMPE: 1/4 ROTATION	GRAU KUNSTSTOFF	seulement pour style 0, 5
13A	725-1650	2	DOUILLE POUR AMPOULE	725-1650	seulement pour style 4, 6, 8, 9
13B	725-1651	2	PORTE AMPOULE	925-1651	seulement pour style 1, 3, 7
14	725-0963	2	AMPOULE ÜLECTRIQUE	#1156	
15	725-1303	1	RESSORT DE SÖRETÜ SIËGE	SI.-SCHALTER SITZ:GELBVERZINKT	
16	725-0980	1	CABLE	725-0980	
17	725-1439	1	RESSORT SÖRETÜ DE SIEGE	SI.-SCHALTER SITZ:GELBVERZINKT	
18	629-0207	1	CABLE D'ADATATION 8.0"LG	629-0207	fsg

**Models 660 thru 679
(Single Cylinder)**

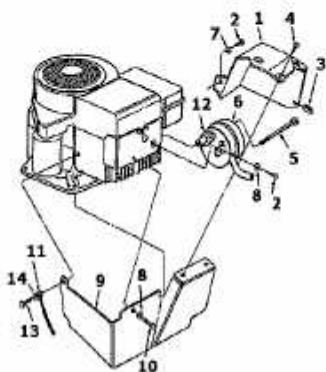

www.emc-motoculture.com

Position	Numéro de pièce	#	Appellation I	Appellation II	Remarque
1	683-0042	1	PROTECTION D'ÉCHAPPEMENT	683-0042	
2	710-0599	1	VIS à SIX PANS CREUX	MTD SPEC-701-01002 or 101617	
3	712-0147	1	ECROU 10-24 U-TYPE	FINISH: SCHWARZ OXIDIERT	
4	710-0429	1	VIS	910-0429	
5	738-0636	1	AXE	7/16ODx3.56x5/16	
6	751-0465	1	VOIR 751-0465A	751-0465	
7	736-0329	1	RONDELLE GROWER	FINISH: 701-01001 24.8195.16	
8	736-0175	1	RONDELLE GROWER: .265x.562x.025	FINISH: 701-01001	
9	16936	1	PROTECTION CHALEUR AVANT	16936	
10	710-0294	1	VIS	710-0294	
11	725-0980	1	CABLE	725-0980	
12	721-0208	1	JOINT ECHAP B/S MONO CYLINDRE	FINISH: B&S #272293	
13	710-0323	1	VIS	FINISH: 701-01000	
14	736-0607	1	RONDELLE	FINISH: MTD STD 701-01001	fsg

www.emc-motoculture.com

**Models 660 thru 679
(Tecumseh)**

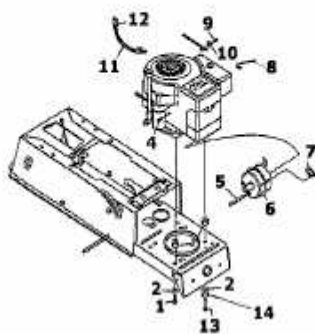

www.emc-motoculture.com

Position	Numéro de pièce	#	Appellation I	Appellation II	Remarque
1	710-1007	1	VIS HEX.TTSEMS3/8- 16:1,500	FINISH:STD 701-01002 or 101616	
2	736-0247	1	RONDELLE 40 X 1.25X .157"	FINISH:MTD SPEC 701- 01001	
3	750-0965	1	ENTRETOISE	750-0965	
4	710-0323	1	VIS	FINISH:701-01000	
5	738-0636	1	AXE	7/16ODx3.56x5/16	
6	751- 0443A	1	POT D'ÜCHAPPEMENT	751-0443A/951-0443A	seulement pour 12 PS,12,5 PS
7	721-0208	1	JOINT ECHAP B/S MONO CYLINDRE	FINISH:B&S #272293	seulement pour 12 PS,12,5 PS
8	726-0197	1	COLLIER	ART.-NR 5601 PB/ELEKTRO	
9	710- 0899A	1	VIS HEXAGONALE	FINISH:701-01000	
10	751- 0360A	1	VOIR 751B221535	751-0360A	
11	751-0535- 15	1	TUYAU / ESSENCE	751-0535 15" LANG	
12	726-0205	1	COLLIER DE SERRAGE DE BOYAU	FINISH:PHOSPHATIERT (GELB)	
13	710-1035	1	VIS HEX.TTSEMS3/8- 16:2.500HXLW	FINISH:MTD SPEC-701- 01002	seulement pour 16 PS
14	750-0965	1	ENTRETOISE	750-0965	seulement pour 16 PS

www.emc-motoculture.com

(Twin Cylinder)

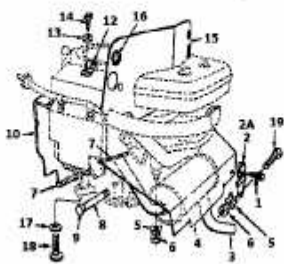

www.emc-motoculture.com

Position	Numéro de pièce	#	Appellation I	Appellation II	Remarque
1	710-0776A		VIS	710-0776A	
2	17450		SUPPORT DROIT	17450	droit
2A	17449		SUPPORT GAUCHE	17449	gauche
3	751-0474		ECHAPPEMENT	751-0474	
4	16934		PROTECTION	16934	
5	736-0170		RONDELLE	FINISH:STD 701-01001 936-0170	
6	712-0267		ÜCROU HEXAGONAL	FINISH:MTD STD 701-01000	
7	731-0511		BORDURE DE PROTECTION	FINISH:SCHWARZ SIEHE ZG.	
8	737-0164		RALLONGE DE VIDANGE	737-0164	
9	737-0143		BOUCHON DE VIDANGE	737-0143	
10	16804C		TOLE COUVRANTE/ DEFLECTEUR TWI	16804C	seulement pour style 8, 9
12	726-0272		COLLIER	FINISH:VERZINKT	
13	736-3067		RONDELLE	736-3067	
14	710-0779A		VIS	FINISH:701-01002 or 101616	
15	783-0161		PROTECTION CHALEUR	783-0161	seulement pour style 3, 5
16	735-0328		RESSORT		
17	736-0247		RONDELLE 40 X 1.25X .157"	FINISH:MTD SPEC 701-01001	
18	710-0502A		VIS HEX. 3/8-16:1.250 LG.	SELBSTSCHN. SPEC / 701-01002	
19	710-1087		VIS	710-1087	fsg

www.emc-motoculture.com

(Vanguard)

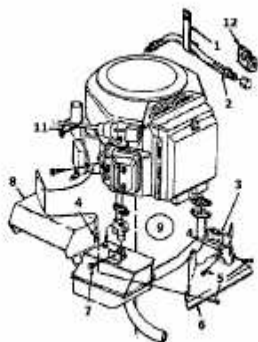

www.emc-motoculture.com

Position	Numéro de lapièce	#	Appellation I	Appellation II	Remarque
1	726-3009		ATTACHE CABLE	726-3009	
2	727-0434		TUYAU / HUILE	727-0434	
3	16877		SUPPORT	16877	
4	712-0147		ECROU 10-24 U-TYPE	FINISH: SCHWARZ OXIDIERT	
5	710-0429		VIS	910-0429	
6	16876A		PROTECTION	16876A	
7	710-0599		VIS ; SIX PANS CREUX	MTD SPEC-701-01002 or 101617	
8	16874		PROTECTION D'ÜCHAPPEMENT	16874	
9	751-0469A		ÉCHAPPEMENT	751-0469A	
11	726-0240		COLLIER DE SERRAGE	SCHWARZ 3/16:7.0 LG	
12	726-0268		ATTACHE	726-0268 NLA!	fsg

www.emc-motoculture.com

(O.H.V.)

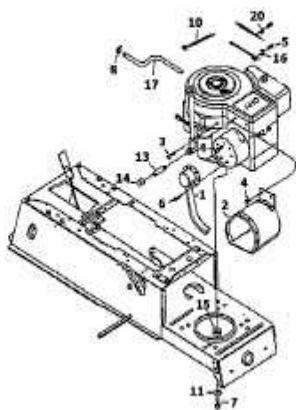

www.emc-motoculture.com

Position	Numéro de lapièce	#	Appellation I	Appellation II	Remarque
1	651-0005		TUYAU D'ÉCHAPPEMENT	651-0005	
2	683-0072		731-04031	683-0072	
3	710-0323		VIS	FINISH:701-01000	
4	710-0599		VIS ; SIX PANS CREUX	MTD SPEC-701-01002 or 101617	
5	710-1237		VIS HEX.:T:#10- 32:0.625:	FINISH:MTD STD 701- 01002	
6	710-0148		VIS	FINISH:701-01002 910- 0148	
7	710-1007		VIS HEX.TTSEMS3/8- 16:1,500	FINISH:STD 701-01002 or 101616	
8	726-0205		COLLIER DE SERRAGE DE BOYAU	FINISH:PHOSPHATIERT (GELB)	
10	726-0197		COLLIER	ART -NR 5601 PB/ELEKTRO	
11	736-0247		RONDELLE 40 X 1.25X .157"	FINISH:MTD SPEC 701- 01001	
13	737-0199		TUBE	FINISH:PHOS & OIL	
14	737-0143		BOUCHON DE VIDANGE	737-0143	
15	750-0965		ENTRETOISE	750-0965	
16	751-0360A		VOIR 751B221535	751-0360A	
17	751-0535-15		TUYAU / ESSENCE	751-0535 15" LANG	
20	751B221535		FIXATION CABLE BOWDEN	751B221535	fsg

www.emc-motocultivo.com

Position	Numéro de pièce	#	Appellation I	Appellation II	Remarque
1	725-1635	1	BATTERIE 12V /20AH	C50N18L-A-CX	
2	725-1426	1	RELAIS DE DEMARRAGE SOLENOID	725-1426 Mutter 712-0271	
3	725-1381	1	FUSIBLE 20 AMPERES	725-1381/925-1381	
4	725-0634	1	COMMUTATEUR	FINISH: SCHWARZ	
5	725-0925	1	AMPÈREMÈTRE ANGULEUX	725-0925	
6	725-1396	1	CONTACTEUR A CLE 6 FICHES	725-1396	
7	725-1657	1	VOIR 725-1657A	725-1657	Embrayage et plateau de coupe
9	629-0204	1	FAISCEAU	629-0204	
12	725-1643	1	CONTACTEUR SECURITE	LANG:FINISH: SIEHE ZG.	Arrière
13	725-1649	2	DOUILLE DE LAMPE: 1/4 ROTATION	GRAU KUNSTSTOFF	seulement pour style 0, 5, 6
13A	725-1650	2	DOUILLE POUR AMPOULE	725-1650	seulement pour style 4, 9
13B	725-1651	2	PORTE AMPOULE	925-1651	seulement pour style 1, 7
14	725-0963	2	AMPOULE ÉLECTRIQUE	#1156	
15	725-1303	1	RESSORT DE SÖRETÜ SIÈGE	SI.-SCHALTER SITZ:GELBVERZINKT	
16	725-0980	1	CABLE	725-0980	
17	725-1439	1	RESSORT SÖRETÜ DE SIÈGE	SI.-SCHALTER SITZ:GELBVERZINKT	
19	629-0130	1	CÂBLE D'ADAPTATION	629-0130	
20	629-0133	1	FAISCEAU 600/700	629-0133 / 929-0133	
21	725-1365	1	LAMPE TEMOIN T.B AMPERMETRE	725-1365 / 925-1365	
24	725-1380	1	FAISCEAU AVEC CABLE	725-1380	
25	725-3018	1	PORTE AMPOULE	725-3018	
26	725-3020	1	AMPOULE	725-3020 / 925-3020	
27	629-0134	1	RÜCKLICHTADAPTER	629-0134	
28	751-0537	1	TEMOIN / INTERR. PRESSION HUI	751-0537	fsg

Position	Numéro de pièce	#	Appellation I	Appellation II	Remarque
1	725-1635	1	BATTERIE 12V /20AH	C50N18L-A-CX	
2	725-1426	1	RELAIS DE DEMARRAGE SOLENOID	725-1426 Mutter 712-0271	
3	725-1625	1	FUSIBLE	725-1625	
4	725-0634	1	COMMUTATEUR	FINISH: SCHWARZ	
5	725-0925	1	AMPÈREMÈTRE ANGULEUX	725-0925	
6	725-0267	1	CONTACTEUR A CLE 5 FICHES	B.6PIN ERS.629-0234) 925-0267	
6A	725-0201	1	CLÜ DE CONTACT	FINISH:VERNICKELT 079.12.707	
7	725-1657	1	VOIR 725-1657A	725-1657	
8	725-1643	1	CONTACTEUR SECURITE	LANG:FINISH: SIEHE ZG.	
9	629-0201	1	FUSEAU	629-0201	sans ampermetre
9A	629-0203	1	FAISCEAU	629-0203	avec ampermetre
12	725-1643	1	CONTACTEUR SECURITE	LANG:FINISH: SIEHE ZG.	
13	725-1649	2	DOUILLE DE LAMPE: 1/4 ROTATION	GRAU KUNSTSTOFF	seulement pour style 0, 5
13A	725-1650	2	DOUILLE POUR AMPOULE	725-1650	seulement pour style 4, 6, 8, 9
13B	725-1651	2	PORTE AMPOULE	925-1651	seulement pour style 1, 3, 7
14	725-0963	2	AMPOULE ÜLECTRIQUE	#1156	
15	725-1303	1	RESSORT DE SÖRETÜ SIËGE	SI.-SCHALTER SITZ:GELBVERZINKT	
16	725-0980	1	CABLE	725-0980	
17	725-1439	1	RESSORT SÖRETÜ DE SIEGE	SI.-SCHALTER SITZ:GELBVERZINKT	
18	629-0207	1	CABLE D'ADATATION 8.0"LG	629-0207	fsg

**Models 660 thru 679
(O.H.V.)**

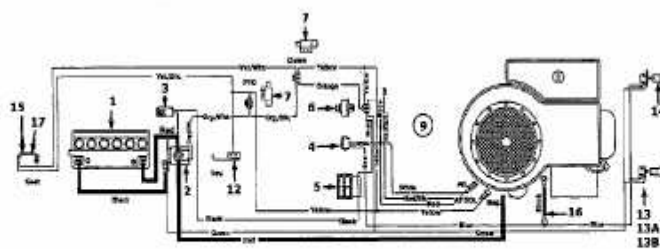

www.emc-motoculture.com

Position	Numéro de pièce	#	Appellation I	Appellation II	Remarque
1	725-1635	1	BATTERIE 12V /20AH	C50N18L-A-CX	
2	725-1426	1	RELAIS DE DEMARRAGE SOLENOID	725-1426 Mutter 712-0271	
3	725-1625	1	FUSIBLE	725-1625	
4	725-0634	1	COMMUTATEUR	FINISH: SCHWARZ	
5	725-0925	1	AMPÈREMETRE ANGULEUX	725-0925	
6	725-1396	1	CONTACTEUR A CLE 6 FICHES	725-1396	
7	725-3169A	1	SECURITE DE LAME	725-3169A/925-3169A	Pedale de freinage et embrayage
8	725-1081		CABLE	725-1081	
9	629-0115	1	FAISCEAU	629-0115	avec ampermetre
9A	629-0105		FUSEAU B&S	629-0105	sans ampermetre
12	725-1643	1	CONTACTEUR SECURITE	LANG:FINISH: SIEHE ZG.	
13	725-1649	2	DOUILLE DE LAMPE: 1/4 ROTATION	GRAU KUNSTSTOFF	seulement pour style 0, 1, 6, 7
13A	725-1650	2	DOUILLE POUR AMPOULE	725-1650	seulement pour style 2, 3, 4, 5, 8, 9
13B	725-1651	2	PORTE AMPOULE	925-1651	seulement pour style 1, 3, 7
14	725-0963	2	AMPOULE ULÉCTRIQUE	#1156	
15	725-1303	1	RESSORT DE S@RETÜ SIËGE	SI.-SCHALTER SITZ:GELBVERZINKT	
16	725-0980	1	CABLE	725-0980	
17	725-1439	1	RESSORT S@RETÜ DE SIEGE	SI.-SCHALTER SITZ:GELBVERZINKT	fsg

**Models 660 thru 679
(Twin Cylinder)**

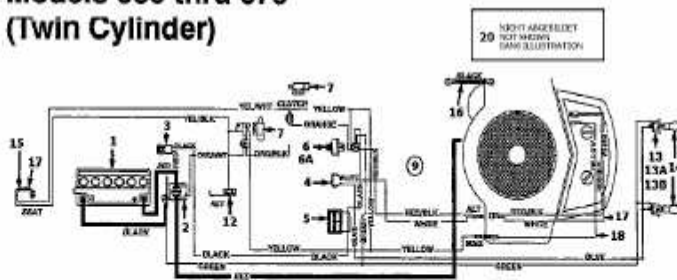

www.emc-motoculture.com

Position	Numéro de pièce	#	Appellation I	Appellation II	Remarque
1	725-1635	1	BATTERIE 12V /20AH	C50N18L-A-CX	
2	725-1426	1	RELAIS DE DEMARRAGE SOLENOID	725-1426 Mutter 712-0271	
3	725-1625	1	FUSIBLE	725-1625	
4	725-0634	1	COMMUTATEUR	FINISH: SCHWARZ	
5	725-0925	1	AMPÈREMÈTRE ANGULEUX	725-0925	
6	725-0267	1	CONTACTEUR A CLE 5 FICHES	B.6PIN ERS.629-0234) 925-0267	
6A	725-0201		CLÜ DE CONTACT	FINISH:VERNICKELT 079.12.707	
7	725-1657	1	VOIR 725-1657A	725-1657	Embrayage et plateau de coupe
9	629-0203	1	FAISCEAU	629-0203	
12	753-0579	1	INTERRUPTEUR DE SECURITE COMP	753-0579	Arrière
13	725-1649	1	DOUILLE DE LAMPE: 1/4 ROTATION	GRAU KUNSTSTOFF	seulement pour style 0, 5
13A	725-1650	1	DOUILLE POUR AMPOULE	725-1650	seulement pour style 8, 9
13B	725-1651	1	PORTE AMPOULE	925-1651	seulement pour style 1, 3, 7
14	725-0963		AMPOULE ÜLECTRIQUE	#1156	
15	725-1303		RESSORT DE S@RETÜ SIËGE	SI.-SCHALTER SITZ:GELBVERZINKT	
16	725-0980		CABLE	725-0980	
17	725-1439		RESSORT S@RETÜ DE SIEGE	SI.-SCHALTER SITZ:GELBVERZINKT	
18	629-0125		FAISCEAU	629-0125	
19	629-0208		FAISCEAU	#18 X 16.0 GELB 629-0208	
20	731-1284		SPIRALSCHLAUCH	731-1284	fsg

Style 4

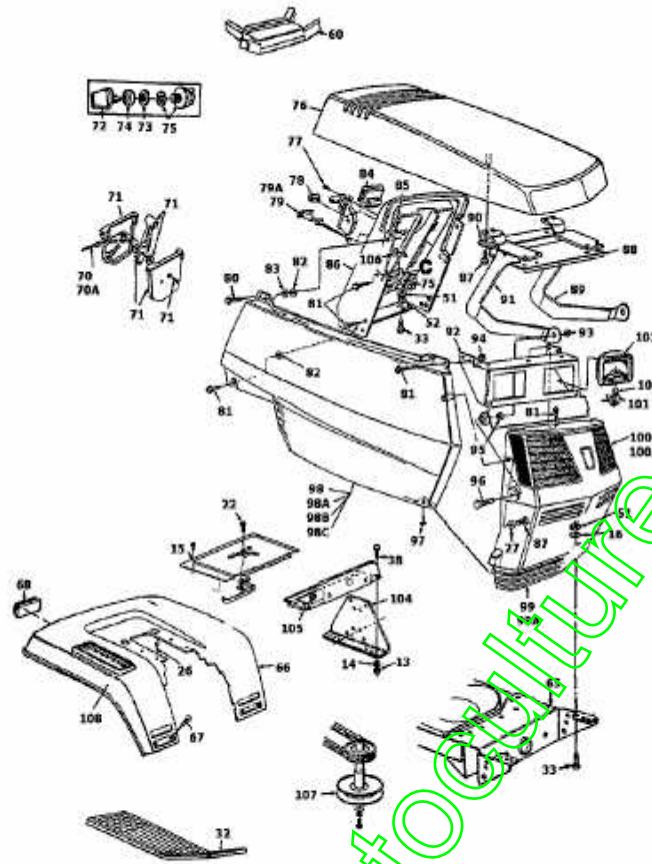

www.emc-motoculture.com

Position	Numéro de lapièce	#	Appellation I	Appellation II	Remarque
13	712-0287		ÜCROU HEXAGONAL 1/4- 20:GR2	FINISH:701-01000 / 912-0287	
14	736-0329		RONDELLE GROWER	FINISH:701-01001 24.8195.16	
15	17286A		COUVERCLE	17286A-0637	
16	736-3078		RONDELLE .344 x 1.00 x .063:HT	FINISH:701-01001	
26	710-0726		VIS 5/16- 12:0.750:HXINDWS	FINISH:MTD STD 701-01002	
27	736-0142		RONDELLE PLATE 1/4X.500X .063	FINISH:701-01000	
32	731-0911		CACHE PIED	731-0911	
32A	731-0912		CACHE PIED	731-0912	
33	710-0118		VIS	FINISH:PHOS & OIL	
38	710-0258		VIS	710-0258	
51	783-0151		PLAQUE SUPPORT LATERALE	783-0151-0638	
52	736-0275		RONDELLE	FINISH:MTD STD 701-01000	
60	731-0955		PROTEGE VOLANT	731-0955	
65	783-0041		VOIR 783-0041A	783-0041A-0637	
66	17324B		COUVERTURE / CHASSIS / ARRIER	17324B	
67	710-0167		VIS 1/4-20x.50" GR 1	FINISH:701-01000	
68	725-3000		RÜCKSTRAHLER	725-3000	
70	746-0776		CABLE ACCELERATEUR B&S	746-0776	seulement pour cylindre single
70A	746-0634		CABLE GAZ 35.0"		seulement pour cylindre double
71	831-0823A		MANETTE GAZ AUTOPORTEE	931-0823A 400/700 o.Gaszug	
72	725-1341B		CLÜ DE CONTACT SANS LOGO	725-1341B	
73	725-1346		ECROU	725-1346	
74	725-1347		CACHE	725-1347	
75	725-1396		CONTACTEUR A CLE 6 FICHES	725-1396	
76	731-1433		CAPOT JAUNE	731-1433 / 931- 1433	
76A	731-1534		CAPOT MTD ROUGE 4 STYLE	731-1534	
77	710-0779A		VIS	FINISH:701-01002 or 101616	
78	725-0634		COMMUTATEUR	FINISH: SCHWARZ	

Position	Numéro de lapièce	#	Appellation I	Appellation II	Remarque
79	746-3021		CABLE POUR CLAPET STARTER	746-3021 *	seulement pour cylindre single
79A	746-0614A		CABLE STARTER 96.5CM	746-0614A	seulement pour cylindre double
80	710-0642		VIS 1/4-20:0.750	MTD SPEC-701- 01002 910-0642	
81	710-0599		VIS à SIX PANS CREUX	MTD SPEC-701- 01002 or 101617	
82	726-0233		RONDELLE	FINISH:PHOS AND OIL	
83	736-0176		RONDELLE PLATE .25x.93X.125"	FINISH:MTD SPEC-100015	
84	725-0925		AMPÈREMETRE ANGULEUX	725-0925	
85	712-0185		ÉCROU EN TÊTE	1/4-20:SPD U- TYPE	
86	731-0961A		TABLEAU DE BORD	731-0961A	
87	710-0896		VIS HEX.:1/4- 14:0,625	FINISH:MTD STD 701-01002	
88	783-0121		CAPOT RENFORCEMENT	783-0121	
89	783-0123		CAPOT FIXATION	783-0123-0637	
90	17762		ENTRETOISE	17762	
92	17223		SUPPORT	17223-0637	
93	712-0158		ECROU EX AF 43064	FINISH:701-01000	
94	712-0107		ECROU EX 43013	712-0107/912- 0107	
95	712-3007		ÉCROU HEX. 5/16-18 GR5	FINISH:MTD STD 701-01000	
96	710-3038		VIS HEX.:5/16- 18:875:GR5:STD	FINISH:701-01000	
97	710-0351		VIS	MTD SPEC- 100016	
98	731-1434		PART LATERAL DROIT JAUNE	731-1434	
98A	731-1435		PART LATERAL GAUCHE JAUNE	731-1435	
98B	731-1536		AILE DROITE ROUGE EX731-0938-	731-1536	rouge
98C	731-1535		AILE GAUCHE ROUGE EX731-0943-	731-1535	rouge
99	731-1442		GRILL (GELB)	731-1442	
99A	731-1537		GRILLE MTD ROUGE	731-1537	
100	731-0949		GLACE GAUCHE	931-0949	
100A	731-0948		GLACE DROIT	731-0948 /931- 0948	
101	725-1650		DOUILLE POUR AMPOULE	725-1650	

Position	Numéro de pièce	#	Appellation I	Appellation II	Remarque
102	725-0963		AMPOULE ÛLECTRIQUE	#1156	
103	731-0705		BOITIER DE PHARE	731-0705	
104	17300E637		SUPPORT TABLEAU DE BORD	SCHWARZ GEPULVERT	
105	17633A		SUPPORT POUR RESERVOIR/BATTER		
106	17782		CLIP: STARTER DE TRACTION	FINISH:VERZINKT	
107	756-0522		POULIE	756-0522	seulement pour 30" plateau de coupe
108	17469		SELECTEUR 7 VITESSES	17469-0637	fsg

www.emc-motoculture.com