

# 102

# 102 Hydro

# 122 Hydro

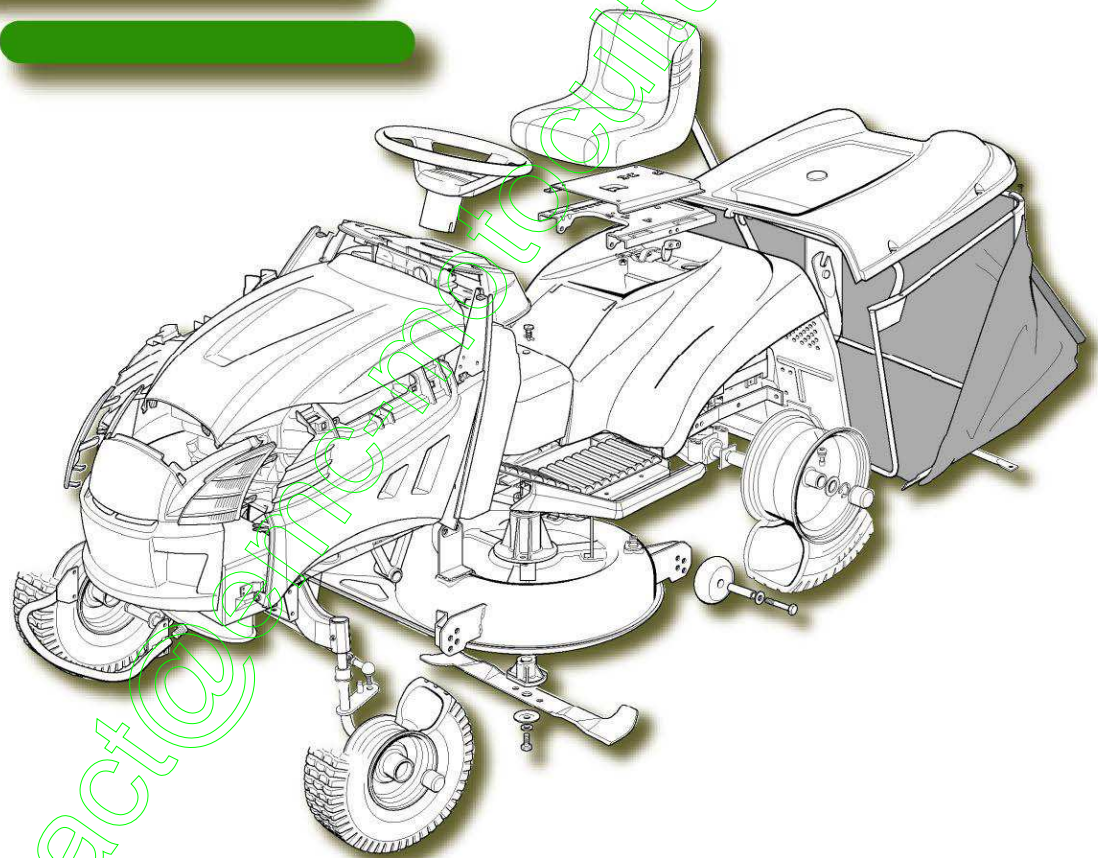

**Catalogo delle parti di ricambio**

**Spare parts catalogue**

**Catalogue des pieces de rechange**

**Ersatzteilkatalog**

# 2006



TC	TCP	TCR	TCB	TCX	TX
102	102 hydro	102 hydro	102 hydro	122 hydro	122 hydro

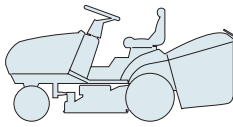

**CATALOGO PARTI DI RICAMBIO  
SPARE PARTS CATALOGUE  
CATALOGUE DE PIECES  
ERSATZTEILKATALOG**

2006
000.0
1 / 4

**COME USARE IL CATALOGO**

**HOW TO USE THE CATALOGUE**

**COMMENT UTILISER LE CATALOGUE**

**WIE IST DER KATALOG ZU BENUTZEN**

**1. Generalità**

Questo catalogo contiene tutte le informazioni necessarie per ordinare correttamente i pezzi di ricambio.

**1. General information**

This catalogue contains all the information necessary for correctly ordering spare parts.

**1. Généralités**

Ce catalogue contient toutes les indications nécessaires pour commander correctement les pièces détachées.

**1. Allgemeines**

Dieser Katalog enthält alle Informationen, die für die korrekte Bestellung von Ersatzteilen erforderlich sind.

**2. Struttura del catalogo**

In ogni pagina del catalogo sono riportate le seguenti indicazioni:

**2. Structure of the catalogue**

Each page of the catalogue has these indications:

**2. Structure du catalogue**

Les indications suivantes sont reportées sur chaque page du catalogue:

**2. Aufbau des Katalogs**

Auf jeder Seite des Katalogs sind die folgenden Angaben wiedergegeben:

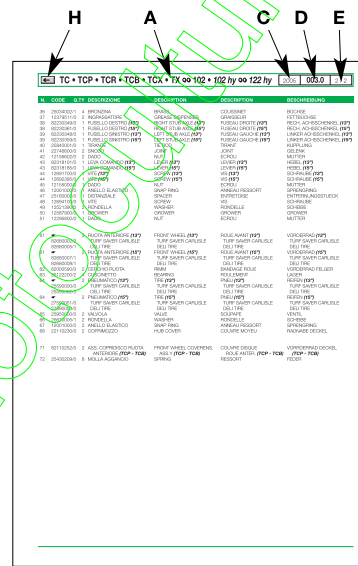
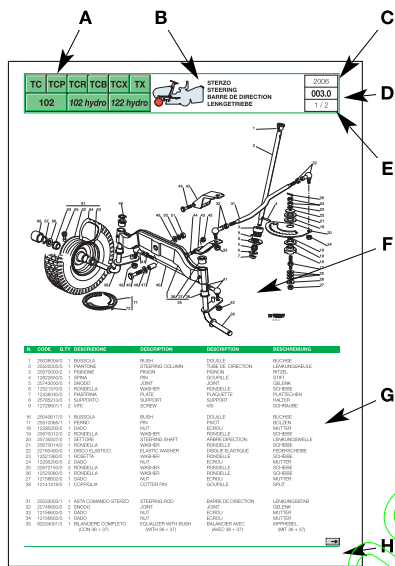

**A.** Macchina o serie di macchine per le quali la pagina è valida.

**A.** Machine or machine series to which the page applies.

**A.** La machine ou la série de machines auxquelles se réfère la page.

**A.** Maschine oder Serie der Maschine, für welche die Seite gültig ist.

**B.** Indicazione del gruppo con la raffigurazione in miniatura della sua collocazione sulla macchina.

**B.** Indication of the unit with a miniature drawing showing its position on the machine.

**B.** L'indication du groupe avec la représentation en miniature de sa position sur la machine.

**B.** Bezeichnung der Gruppe mit einer Miniaturdarstellung ihrer Anbringung auf der Maschine.

**C.** Anno di produzione della macchina a cui si riferisce.

**C.** Year of production of the machine concerned.

**C.** L'année de fabrication de la machine concernée.

**C.** Herstellungsjahr der betreffenden Maschine.

**D.** Numerazione progressiva della tavola, secondo il seguente criterio:

- le prime tre cifre indicano il numero progressivo;
- le eventuali lettere che seguono indicano le diverse versioni alternative di quel gruppo;
- la cifra dopo il punto indica un eventuale aggiornamento nel corso della annualità indicata al punto 3.

**D.** Progressive numbering of the table, arranged as follows:

- the first three numbers are the progressive number;
- any letters that follow will indicate the various alternative versions of that unit;
- the number after the dot is for any updates during the year given at point 3.

**D.** La numérotation progressive du tableau, selon le critère suivant:

- les trois premiers chiffres indiquent le numéro progressif;
- les éventuelles lettres qui suivent indiquent les différentes versions alternatives de ce groupe;
- le chiffre après le point indique l'éventuelle mise à jour effectuée au cours de l'année indiquée au point 3.

**D.** Progressive Numerierung der Tafel nach folgendem Kriterium:

- die ersten drei Ziffern bezeichnen die progressive Nummer;
- die eventuellen Buchstaben, die folgen, bezeichnen die verschiedenen alternativen Versionen dieser Gruppe;
- die Ziffer nach dem Punkt bezeichnet einen eventuellen neueren Stand im Laufe des Jahrgangs, der in Punkt 3 angegeben ist.

Esempio:

005b.0 =

005 Gruppo Motore  
b 18 - 20 - 22 HP B&S  
.0 Prima stesura

Example:

005b.0 =

005 Engine unit  
b 18 - 20 - 22 HP B&S  
.0 First copy

Exemple

005b.0 =

005 Groupe Moteur  
b 18 - 20 - 22 HP B&S  
.0 Première rédaction

Beispiel:

005b.0 =

005 Motorgruppe  
b 18 - 20 - 22 HP B&S  
.0 Erste Ausgabe



**E.** Numero della pagina e numero totale delle pagine necessarie per la descrizione del gruppo.

**F.** Vista esplosa del gruppo.

**G.** Descrizione completa dei singoli particolari, con codice e quantità di pezzi.

**H.** Indicazione della presenza di altre pagine di seguito.

Nelle pagine di seguito, sono riportate nuovamente le indicazioni relative ai punti A - C - D - E - G e H.

**E.** Page number and total number of pages necessary for the description of the unit.

**F.** Exploded view of the unit.

**G.** Full description of each part, with code number and number of pieces.

**H.** Indication of additional pages.

The additional pages repeat the indications as at points A - C - D - E - G and H.

**E.** Numéro de la page et nombre total des pages nécessaires pour la description du groupe.

**F.** Vue éclatée du groupe.

**G.** Description complète de chaque élément, avec code et quantité des pièces.

**H.** Indication de la présence d'autres pages successives.

Les pages qui suivent reportent, elles aussi, les indications concernant les points A - C - D - E - G et H.

**E.** Seitenzahl und Gesamtzahl der Seiten, die für die Beschreibung der Gruppe erforderlich sind.

**F.** Explosionszeichnung der Gruppe.

**G.** Vollständige Beschreibung der Einzelteile, mit Kodenummer und Menge der Teile.

**H.** Angabe über die Präsenz weiterer folgender Seiten.

Auf den nachfolgenden Seiten sind die Bezeichnungen, die sich auf die Punkte A - C - D - E - G und H beziehen, erneut wiedergegeben.

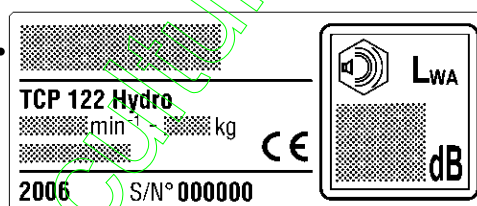
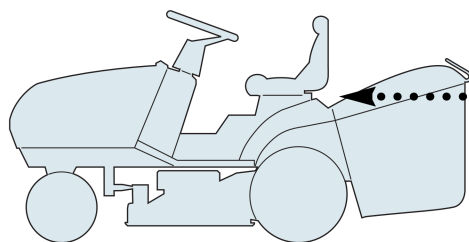

### 3. Ordine di ricambi

Prima di formulare un ordine di ricambi, accertare che il catalogo corrisponda all'anno di costruzione della macchina, riportato sulla targhetta di identificazione.

Ogni ordine di ricambi deve necessariamente contenere:

- modello della macchina;
- quantità di pezzi richiesta;
- descrizione (eventuale);
- numero di codice del pezzo;
- destinatario
- mezzo di spedizione.

#### Esempio di ordinazione:

Su una macchina TCP122 del 2006, con motore B&S da 18 HP si deve sostituire il silenziatore di scarico. Tale particolare è raffigurato nella tavola **005b.0** alla posizione **31**, a cui corrisponde il codice **82750003/0**.

L'ordinazione sarà quindi:

per TCP122:  
n. 1 silenziatore cod. 82750003/0  
da inviare a .....  
a mezzo .....

#### Nota

Per le parti non codificate del motore e della trasmissione contrassegnate con (\*), occorre rivolgersi al Costruttore.

### 3. Spare parts order

Before putting in an order for spare parts, make sure that the catalogue is the one applying to the machine's year of manufacture, as shown on the identification plate attached to the machine.

Each spare parts order must include:

- the model of the machine;
- the number of parts required;
- description (incidental);
- the code number for the item;
- the destination;
- the method of shipping.

#### An example of an order:

The exhaust pipe silencer on a TCP122 machine, produced in 2006 with an B&S 18 HP engine, must be replaced. This part is shown in table **005b.0** in position **31**, and has the code number **82750003/0**.

The order will therefore be:

for TCP122:  
1 silencer - code 82750003/0  
to be sent to .....  
method of shipping .....

#### Note

For parts of the engine and the transmission without code numbers, marked by (\*), it's necessary to contact the manufacturer.

### 3. Commande pièces détachées

Avant de passer une commande pour des pièces détachées, s'assurer que le catalogue est celui correspondant à l'année de fabrication de la machine reportée sur la plaquette d'identification.

Chaque commande de pièces détachées doit obligatoirement contenir:

- modèle de la machine;
- quantité de pièces demandée;
- description (éventuelle);
- numéro de code de la pièce;
- le destinataire;
- le moyen de transport.

#### Exemple de commande:

Sur une machine TCP102 du 2006, avec moteur B&S de 18 CH, il faut remplacer le silencieux d'échappement. Cette pièce est représentée sur le tableau **005b.0** à la position **31**, correspondant au code **82750003/0**.

La commande sera donc formulée de la façon suivante:

pour TCP122:  
1 silencieux - code 82750003/0  
à envoyer à .....  
par .....

#### Remarque

Pour les pièces non codées du moteur et de la transmission, indiquées avec (\*), il faut s'adresser au Fabricant.

### 3. Ersatzteilbestellungen

Ehe eine Ersatzteilbestellung geschrieben wird, muß man sich vergewissern, daß der Katalog mit dem Herstellungsjahr der Maschine übereinstimmt, auf dem Kennzeichenschild wiedergegeben.

Jede Ersatzteilbestellung muß enthalten:

- Modell der Maschine;
- Menge der angeforderten Teile;
- Bezeichnung (eventuell);
- Artikelnummer des Teils;
- Empfänger;
- Versandart.

#### Beispiel einer Bestellung:

Auf einer Maschine TCP122 von 2006, mit Motor B&S mit 18 PS muß der Auspufftopf ersetzt werden. Dieses Einzelteil ist auf der Tafel **005b.0** unter der Position **31** dargestellt, der dem Code **82750003/0** entspricht.

Die Bestellung lautet demnach:

Für TCP122:  
1 Auspuff - Kode 82750003/0  
zu versenden an .....  
mit .....

#### Anmerkung

Für die nicht codierten Teile des Motors und des Antriebs, die mit (\*) gekennzeichnet sind, muß man sich an den Hersteller wenden.

<b>TC</b>	<b>TCP</b>	<b>TCR</b>	<b>TCB</b>	<b>TCX</b>	<b>TX</b>
<b>102</b>	<b>102 hydro</b>	<b>122 hydro</b>			

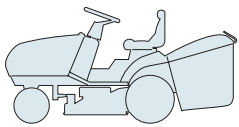

**INDICE DELLE TAVOLE**  
**INDEX OF TABLES**  
**SOMMAIRE DES TABLEAUX**  
**INHALT DER TAFELN**

2006
<b>000.0</b>
3 / 4

**TELAIO**  
**CHASSIS**  
**CHASSIS**  
**RAHMENSATZ**

↪ [001](#)

**CARROZZERIA**  
**BODY**  
**CARROSSERIE**  
**KARROSSERIE**

TC ..... ↪ [002](#)  
 TCP ..... ↪ [002a](#)  
 TCR ..... ↪ [002b](#)  
 TCB ..... ↪ [002c](#)  
 TCX ..... ↪ [002d](#)  
 TX ..... ↪ [002e](#)

**STERZO**  
**STEERING**  
**BARRE DE DIRECTION**  
**LENKGETRIEBE**

↪ [003](#)

**COMANDO TRASMISSIONE E FRENO**  
**DRIVE AND BRAKE CONTROLS**  
**COMMANDE TRANSMISSION ET FREIN**  
**GETRIEBE UND BREMSE ANTRIEB**

102 ..... ↪ [004M](#)  
 102 hydro / 122 hydro ..... ↪ [004Y](#)

**MOTORE**  
**ENGINE**  
**MOTEUR**  
**MOTOR**

B&S 12 - 12,5 HP ..... ↪ [005](#)  
 15 - 15,5 - 17,5 HP ..... ↪ [005a](#)  
 18 - 20 - 22 HP ..... ↪ [005b](#)  
 TECUMSEH 13,5 HP ..... ↪ [005c](#)  
 14,5 - 15 - 16 HP ..... ↪ [005d](#)  
 20 HP ..... ↪ [005e](#)  
 HONDA GCV 530 ..... ↪ [005f](#)  
 GCV 610 ..... ↪ [005g](#)  
 KOHLER 16 - 18 HP ..... ↪ [005h](#)  
 20 - 22 HP ..... ↪ [005j](#)

**TRASMISSIONE**  
**TRANSMISSION**  
**TRANSMISSION**  
**GETRIEBE**

102 ..... ↪ [006M](#)  
 102 hydro / 122 hydro ..... ↪ [006Y](#)

**SOLLEVAMENTO PIATTO DI TAGLIO**  
**CUTTING PLATE LIFTING**  
**SOULEVEMENT PLATEAU DE COUPE**  
**SCHNEIDWERKZEUG AUFHEBESATZ**

↪ [007](#)

**PIATTO DI TAGLIO (1)**  
**CUTTING PLATE (1)**  
**PLATEAU DE COUPE (1)**  
**SCHNEIDWERKZEUG (1)**

↪ [008](#)



PIATTO DI TAGLIO (2)  
 CUTTING PLATE (2)  
 PLATEAU DE COUPE (2)  
 SCHNEIDWERKZEUG (2)

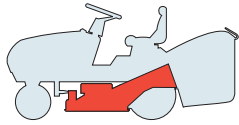

↪ 009

SACCO  
 GRASSCATCHER  
 BAC  
 AUFFANGSACK

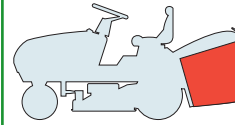

TC - TCP - TCR - TCB - TCX ↪ 010

TX ..... ↪ 010a

PARTI ELETTRICHE  
 ELECTRICAL PARTS  
 PARTIES ELECTRIQUES  
 ELETRISCHETEILE

TC - TCP - TCR - TCB - TCX  
 B&S-TECUMSEH-KOHLER ↪ 011  
 HONDA..... ↪ 011a

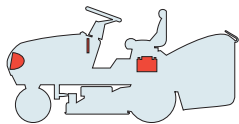

TX  
 B&S-TECUMSEH-KOHLER ↪ 011b  
 HONDA..... ↪ 011c

ACCESSORI A RICHIESTA  
 OPTIONALS ON REQUEST  
 ACCESSOIRES SUR DEMANDE  
 ZUBEHOERE NACH ANFRAGE

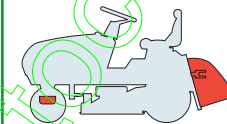

↪ 012

ETICHETTE  
 LABELS  
 ETIQUETTES  
 KLEBZETTEL

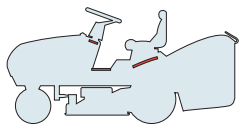

↪ 013

contact@emc-motocultiv.com

TC TCP TCR TCB TCX TX

102 102 hydro 122 hydro

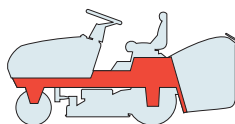

TELAIO  
CHASSIS  
CHASSIS  
RAHMENSATZ

2006

001.0

1 / 2

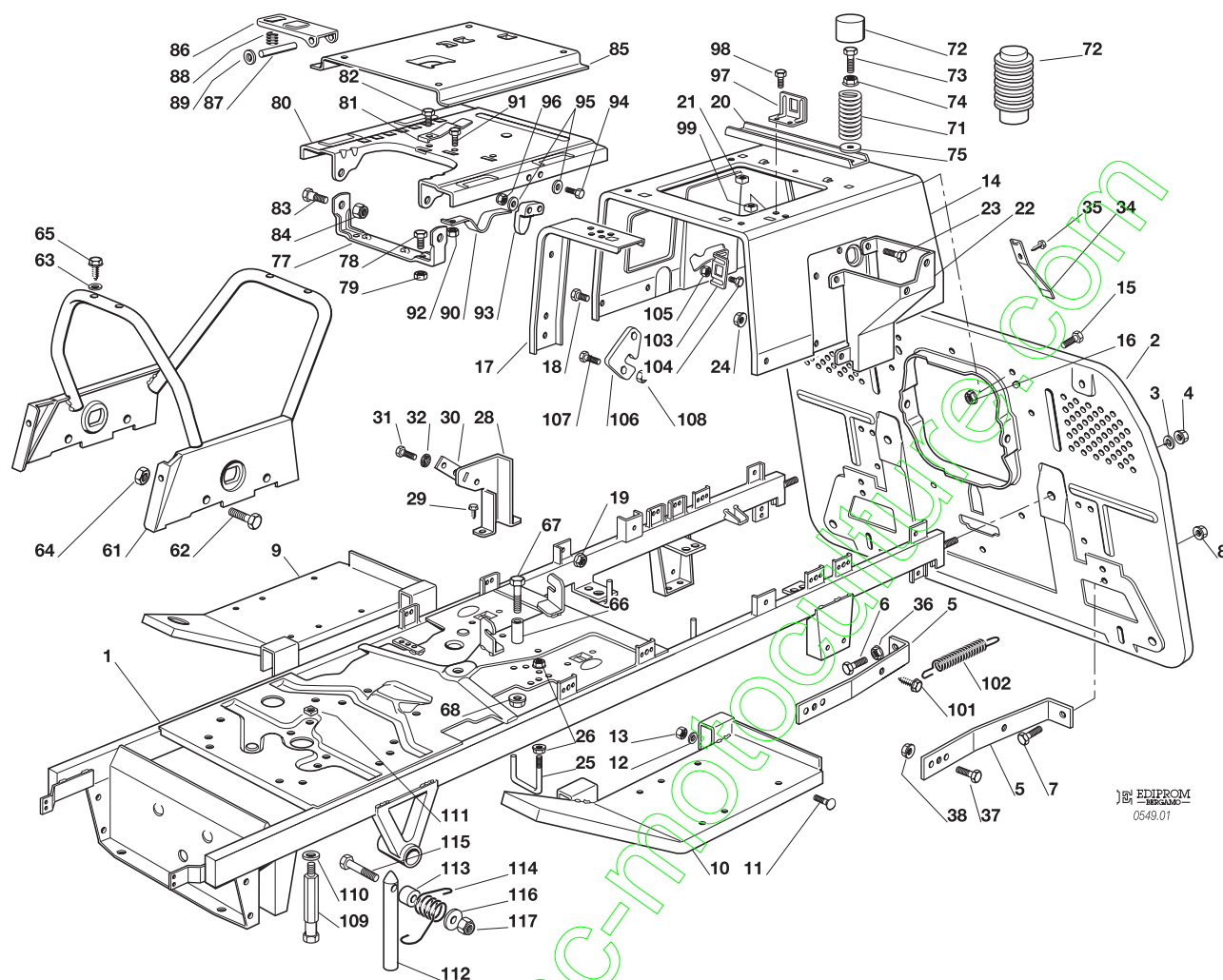

EDIPROM  
-SERVIZIO-  
0549.01

N.	CODE	Q.TY	DESCRIZIONE	DESCRIPTION	DESCRIPTION	BESCHREIBUNG
1	82800075/0	1	TELAIO	CHASSIS	CHASSIS	RAHMENSATZ
2	82547011/6	1	PIASTRA	PLATE	PLAQUE	PLATTE
3	12585100/0	2	GROWER	GROWER	GROWER	GROWER
4	12295200/0	2	DADO	NUT	ECROU	MUTTER
5	25774273/1	2	RINFORZO	STIFFENING	REINFORCEMENT	VERSTAERKUNG
6	12691100/0	1	VITE	SCREW	VIS	SCHRAUBE
7	12793102/0	3	VITE	SCREW	VIS	SCHRAUBE
8	12293201/0	4	DADO	NUT	ECROU	MUTTER
9	82510041/1	1	SUPPORTO PEDANA DESTRO	RIGHT FOOTBOARD SUPPORT	SUPPORT MARCHEPIED DROITE	RECHTE FUSSBRETTHALTER
10	82510043/1	1	SUPPORTO PEDANA SINISTRO	LEFT FOOTBOARD SUPPORT	SUPPORT MARCHEPIED GAUCHE	LINKE FUSSBRETTHALTER
11	12815245/0	4	VITE	SCREW	VIS	SCHRAUBE
12	12523040/0	4	ROSETTA	WASHER	RONDELLE	SCHEIBE
13	12154510/0	4	DADO	NUT	ECROU	MUTTER
14	25785133/3	1	SUPPORTO SEDILE	SEAT SUPPORT	SUPPORT SIEGE	SITZHALTER
15	12791011/0	5	VITE	SCREW	VIS	SCHRAUBE
16	12292102/0	5	DADO	NUT	ECROU	MUTTER
17	25650065/0	2	RINFORZO	STIFFENING	REINFORCEMENT	VERSTAERKUNG
18	12791011/0	6	VITE	SCREW	VIS	SCHRAUBE
19	12292102/0	6	DADO	NUT	ECROU	MUTTER
20	25650067/0	1	RINFORZO	STIFFENING	REINFORCEMENT	VERSTAERKUNG
21	12360420/0	2	DADO	NUT	ECROU	MUTTER
22	25785137/0	1	SUPPORTO	SUPPORT	SUPPORT	HALTER
23	12791011/0	4	VITE	SCREW	VIS	SCHRAUBE
24	12292102/0	4	DADO	NUT	ECROU	MUTTER
25	25580019/0	1	PIOLO GUIDACINGHIA	BELT GUIDE	GUIDE DE COURROIRE	RIEMENFÜHRUNG
26	12292102/0	2	DADO	NUT	ECROU	MUTTER
28	25785141/0	1	SUPPORTO	SUPPORT	SUPPORT	HALTER
29	12735110/0	2	VITE	SCREW	VIS	SCHRAUBE
30	27546019/0	1	PIASTRINA (hydro)	PLATE (hydro)	PLAQUETTE (hydro)	PLATTE (hydro)
31	12735602/0	2	VITE (hydro)	SCREW (hydro)	VIS (hydro)	SCHRAUBE (hydro)
32	12581100/0	2	ROSETTA (hydro)	WASHER (hydro)	RONDELLE (hydro)	SCHEIBE (hydro)



N.	CODE	Q.TY	DESCRIZIONE	DESCRIPTION	DESCRIPTION	BESCHREIBUNG
34	25430238/0	1	MOLLA	SPRING	RESSORT	FEDER
35	12731580/0	1	VITE	SCREW	VIS	SCHRAUBE
36	12293200/0	1	DADO	NUT	ECROU	MUTTER
37	12793102/0	2	VITE	SCREW	VIS	SCHRAUBE
38	12293201/0	2	DADO	NUT	ECROU	MUTTER
61	82650041/1	1	TELAIO CENTRALE	CHASSIS	CHASSIS	RAHMENSATZ
62	12792611/0	4	VITE	SCREW	VIS	SCHRAUBE
63	12521330/0	4	ROSETTA	WASHER	RONDELLE	SCHEIBE
64	12293201/0	4	DADO	NUT	ECROU	MUTTER
65	12731350/0	4	VITE	SCREW	VIS	SCHRAUBE
66	22167840/0	1	DISTANZIALE (ruote 15")	SPACER (wheels 15")	ENTRETOISE (roues 15")	ENTFERNUNGSSTÜCK (räder 15")
67	12691200/0	1	VITE (ruote 15")	SCREW (wheels 15")	VIS (roues 15")	SCHRAUBE (räder 15")
68	12293201/0	1	DADO (ruote 15")	NUT (wheels 15")	ECROU (roues 15")	MUTTER (räder 15")
71	25430205/1	2	MOLLA	SPRING	RESSORT	FEDER
72	25122000/2	2	CUFFIA	HOOD	PROTECTEUR	SCHUTZKASTEN
	25737002/0	2	CUFFIA (TX)	HOOD (TX)	PROTECTEUR (TX)	SCHUTZKASTEN (TX)
73	25943001/0	2	VITE	SCREW	VIS	SCHRAUBE
74	12293201/0	2	DADO	NUT	ECROU	MUTTER
75	12523070/0	2	ROSETTA	WASHER	RONDELLE	SCHEIBE
77	82774207/0	1	STAFFA SUPP. SEDILE	SEAT CLAMP SUPPORT	ETRIER SUPPORT SIEGE	BRIDE F. SITZHALTER
78	12792611/0	2	VITE	SCREW	VIS	SCHRAUBE
79	12293201/0	2	DADO	NUT	ECROU	MUTTER
80	25785149/2	1	SUPP. SEDILE FISSO	FIXED SEAT SUPP.	SUPPORT SIEGE FIXE	FEST SITZHALTER
81	25430203/0	1	MOLLA ARRESTO	SPRING	RESSORT D'ARRET	RASTFEDER
82	12731580/0	1	VITE	SCREW	VIS	SCHRAUBE
83	22524970/2	2	PERNO	PIN	PIVOT	BOLZEN
84	12155010/0	2	DADO	NUT	ECROU	MUTTER
85	25785147/0	1	SUPPORTO SEDILE	SEAT SUPPORT	SUPPORT SIEGE	SITZHALTER
86	25318109/0	1	LEVA ARRESTO	STOP LEVER	LEVIER D'ARRET	ABSTELLHEBEL
87	25510000/0	1	PERNO	PIN	PIVOT	BOLZEN
88	25430202/0	1	MOLLA	SPRING	RESSORT	FEDER
89	12604897/0	2	RONDELLA	WASHER	RONDELLE	SCHEIBE
90	25430223/2	1	MOLLA	SPRING	RESSORT	FEDER
91	12789000/0	1	VITE	SCREW	VIS	SCHRAUBE
92	12154330/0	1	DADO	NUT	ECROU	MUTTER
93	25060033/0	1	CAMMA	CAM	CAME	NOCKEN
94	12789020/0	2	VITE	SCREW	VIS	SCHRAUBE
95	12521320/0	4	RONDELLA	WASHER	RONDELLE	SCHEIBE
96	12372550/0	2	DADO	NUT	ECROU	MUTTER
97	25755025/1	1	SQUADRETTA	BRACKET	EQUERRE-SUPPORT	WINKEL
98	12735110/0	2	VITE	SCREW	VIS	SCHRAUBE
99	12437502/0	2	DADO	NUT	ECROU	MUTTER
			<b>Nei modelli con innesto delle lame a leva:</b>	<b>For models with engagement of the blades by lever:</b>	<b>Dans les modèles avec em-brayage des lames à levier:</b>	<b>Bei Modellen mit Hebelschaltung der Messer:</b>
101	12735120/0	1	VITE	SCREW	VIS	SCHRAUBE
102	25430235/0	1	MOLLA	SPRING	RESSORT	FEDER
103	25755016/0	1	SQUADRETTA	BRACKET	EQUERRE-SUPPORT	WINKEL
104	12789000/0	2	VITE	SCREW	VIS	SCHRAUBE
105	12154330/0	2	DADO	NUT	ECROU	MUTTER
106	25486020/0	1	PATTINO	SHOE	BLOC DE GLISSEMENT	GLEITBLOCK
107	12789000/0	2	VITE	SCREW	VIS	SCHRAUBE
108	12154330/0	2	DADO	NUT	ECROU	MUTTER
109	25580014/1	1	PIOLO GUIDACINGHIA	BELT GUIDE	GUIDE DE COURROIRE	RIEMENFÜHRUNG
110	12523060/0	1	ROSETTA	WASHER	RONDELLE	SCHEIBE
111	12360425/0	1	DADO	NUT	ECROU	MUTTER
112	25580022/0	1	PIOLO GUIDACINGHIA	BELT GUIDE	GUIDE DE COURROIRE	RIEMENFÜHRUNG
113	25160032/0	1	DISTANZIALE	SPACER	ENTRETOISE	ENTFERNUNGSSTÜCK
114	25430241/0	1	MOLLA	SPRING	RESSORT	FEDER
115	12689515/0	1	VITE	SCREW	VIS	SCHRAUBE
116	12523050/0	1	RONDELLA	WASHER	RONDELLE	SCHEIBE
117	12154510/0	1	DADO	NUT	ECROU	MUTTER
			<b>Modelli con sollevamento manuale:</b>	<b>Models with manual tipping:</b>	<b>Modèles avec renversement manuelle:</b>	<b>Modellen mit Handbedienung:</b>
2	82547011/6	1	PIASTRA	PLATE	PLAQUE	PLATTE
			<b>Modelli con sollevamento elettrico:</b>	<b>Models with electric tipping:</b>	<b>Modèles avec renversement électrique:</b>	<b>Modellen mit elektrischer Bedienung:</b>
2	82547039/0	1	PIASTRA	PLATE	PLAQUE	PLATTE

TC	TCP	TCR	TCB	TCX	TX
102	102 hydro	102 hydro	102 hydro	122 hydro	122 hydro

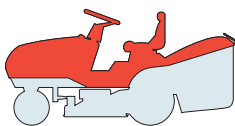

CARROZZERIA  
BODY  
CARROSSERIE  
KARROSSERIE

2006

002.0

1 / 2

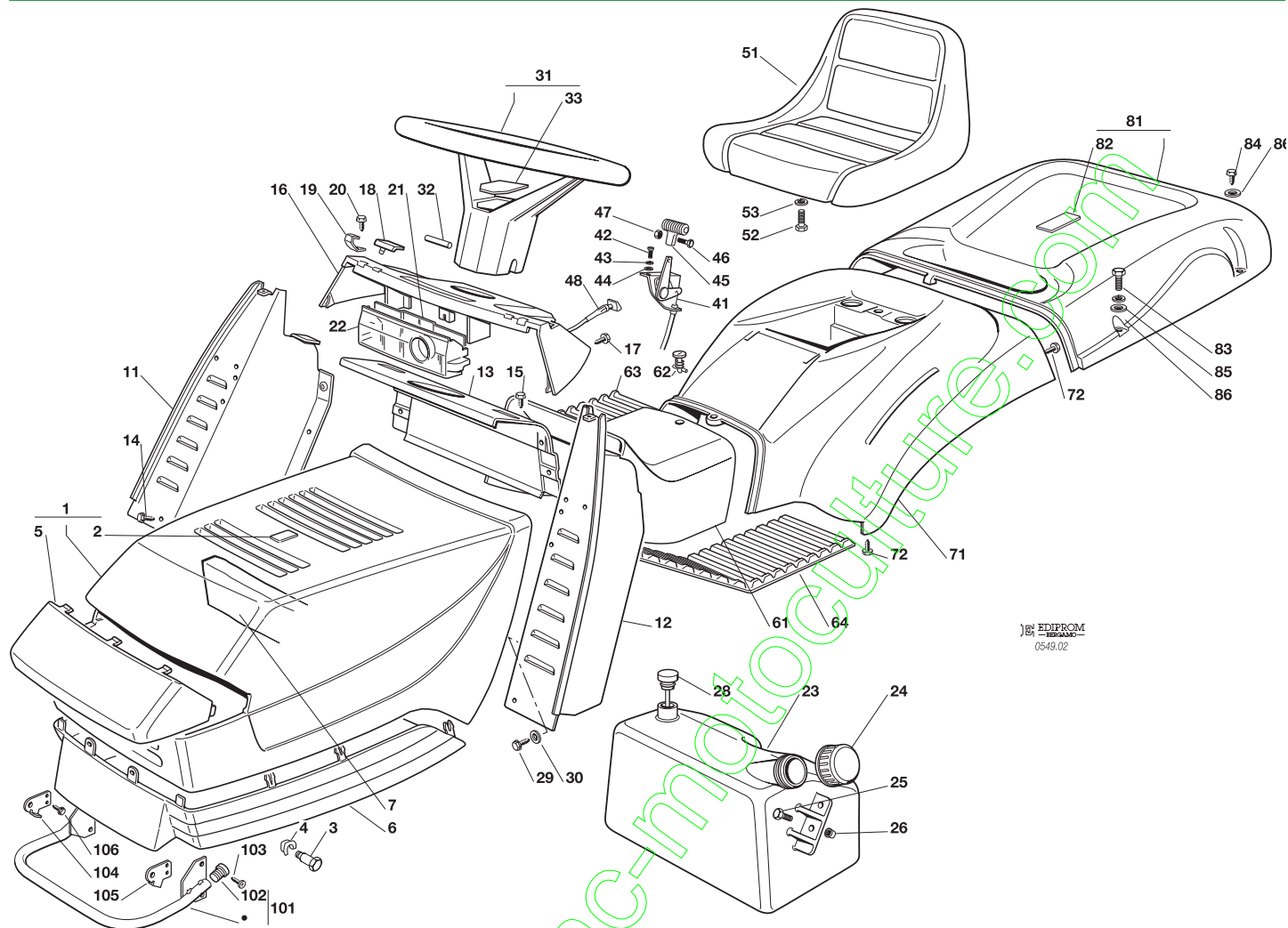

EDIPROM  
0549.02

N.	CODE	Q.TY	DESCRIZIONE	DESCRIPTION	DESCRIPTION	BESCHREIBUNG
1	82076802/2 82076803/0 82076932/0 82076808/0	1	COFANO SUPERIORE ROSSO VERDE ARANCIONE BLU	UPPER ENGINE HOOD RED GREEN ORANGE BLUE	CAPOT SUPERIEURE ROUGE VERT ORANGE BLEU	OBERHAUBESATZ ROT GRÜN DUNKELORANGE BLAU
2	25547016/2 25547015/0 25547144/0 25547024/0	1	PIASTRINA ROSSA VERDE ARANCIONE BLU	PLATE RED GREEN ORANGE BLUE	PLAQUE ROUGE VERT ORANGE BLEU	PLATTE ROT GRÜN DUNKELORANGE BLAU
3	25510023/1	2	PERNO	PIN	PIVOT	BOLZEN
4	12436050/0	2	PIASTRINA	PLATE	PLAQUE	PLATTE
5	25410858/0	1	MASCHERINA	GRILL	PANNEAU	SCHUTZ
6	25076802/0	1	COFANO INFERIORE	LOWER ENGINE HOOD	CAPOT INFERIEURE	UNTERHAUBESATZ
7	25730000/0 25730001/0	1	SEPARATORE ASPIRAZ. SEPARATORE ASPIRAZ.	INTAKE SEPARATOR INTAKE SEPARATOR	SEPARATEUR ASPIRAT. SEPARATEUR ASPIRAT.	AUGENABSCHIEDER AUGENABSCHIEDER
11	82785022/7	1	SUPP. CRUSCOTTO DESTRO	RIGHT DASHBOARD SUPP.	SUPPORT TABLEAU DROITE	RECHTER KONSOLEHALTER
12	82785021/6	1	SUPP. CRUSCOTTO SIN.	LEFT DASHBOARD SUPP.	SUPPORT TABLEAU GAUCHE	LINKER KONSOLEHALTER
13	82785137/0	1	SUPP. CRUSCOTTO CENTR.	CENTRAL DASHBOARD SUPP.	SUPPORT TABLEAU CENTR.	ZENTR. KONSOLEHALTER
14	12735110/0	2	VITE	SCREW	VIS	SCHRAUBE
15	12735110/0	4	VITE	SCREW	VIS	SCHRAUBE
16	25120152/1	1	CRUSCOTTO	DASHBOARD	TABLEAU DE BORD	KONSOLE
17	12728440/0	4	VITE	SCREW	VIS	SCHRAUBE
18	25260000/0	2	GOMMINO	GROMMET	PROTECTION	SCHUTZ
19	25430215/0	2	MOLLA AGGANCI	COUPLING SPRING	RESSORT ACCROCHAGE	KUPPLUNGSFEDER
20	12728440/0	2	VITE	SCREW	VIS	SCHRAUBE
21	25600007/0	1	PROTEZIONE SCHEDA	CARD PROTECTION	PROTECTION DE CARTE	KARTESCHUTZ
22	25600051/0	1	PROTEZIONE SCHEDA	CARD PROTECTION	PROTECTION DE CARTE	KARTESCHUTZ
23	25735110/3 25735111/3	1	SERBATOIO SERBATOIO	TANK TANK	RESERVOIR RESERVOIR	TANK TANK
24	25795000/1	1	TAPPO	CAP	BOUCHON	TANKVERSCHLUSS
25	12789197/0	2	VITE	SCREW	VIS	SCHRAUBE
26	12500092/0	2	RIVETTO	RIVET	RIVET	NIET
28	25290000/0	1	INDICATORE LIVELLO	FUEL LEVEL INDICATOR	INDICATEUR NIVEAU	KRAFTSTOFFMESSER
29	12731350/0	2	VITE	SCREW	VIS	SCHRAUBE





N.	CODE	Q.TY	DESCRIZIONE	DESCRIPTION	DESCRIPTION	BESCHREIBUNG
30	12521330/0	2	RONDELLA	WASHER	RONDELLE	SCHEIBE
31	25961213/0	1	VOLANTE	STEERING WHEEL	VOLANT	LENKRAD
32	12620299/0	1	SPINA	PIN	GOUPILLE	STIFT
33	25120231/0	1	TAPPO	CAP	BOUCHON	STOPFEN
41	82000200/1	1	ACCELERATORE (1235)	ACCELERATOR (1235)	ACCELERATEUR (1235)	GAS ZUG (1235)
	82000201/2	1	ACCELERATORE (46)	ACCELERATOR (46)	ACCELERATEUR (46)	GAS ZUG (46)
42	12788512/0	2	VITE	SCREW	VIS	SCHRAUBE
43	12581200/0	2	GROWER	GROWER	GROWER	GROWER
44	12521310/0	2	RONDELLA	WASHER	RONDELLE	SCHEIBE
45	25394501/0	1	MANOPOLINA	HANDLE	POIGNE	GRIF
46	12726388/0	1	VITE	SCREW	VIS	SCHRAUBE
47	12290800/0	1	DADO	NUT	ECROU	MUTTER
48	25090001/2	1	COMANDO STARTER (46)	CHOKE CONTROL (46)	COMMANDE STARTER (46)	STARTER BETAETIGUNG (46)
51	25722450/1	1	SEDILE	SEAT	SIEGE	SITZ
52	12793101/0	4	VITE	SCREW	VIS	SCHRAUBE
53	12583500/0	4	GROWER	GROWER	GROWER	GROWER
61	•	1	COPERTURA CENTRALE	COVER	COUVRE	KAPPE
	25110136/1		ROSSO	RED	ROUGE	ROT
	25110135/0		VERDE	GREEN	VERT	GRÜN
	25110100/1		ARANCIONE	ORANGE	ORANGE	DUNKELORANGE
	25110132/0		BLU	BLUE	BLEU	BLAU
61	•	1	COPERTURA CENTR. (hydro)	COVER (hydro)	COUVRE (hydro)	KAPPE (hydro)
	25110239/1		ROSSO	RED	ROUGE	ROT
	25110240/0		VERDE	GREEN	VERT	GRÜN
	25110099/1		ARANCIONE	ORANGE	ORANGE	DUNKELORANGE
	25110242/0		BLU	BLUE	BLEU	BLAU
62	25580020/0	1	PERNO	PIVOT	GOUJON	STIFT
63	25110270/0	1	COPRIPEDANA DESTRA	RIGHT FOOTBOARD COVER	COUVRE MARCHEPIED DRO.	RECHTE FUSSBRETTDECKEL
64	25110260/2	1	COPRIPEDANA SINISTRA	LEFT FOOTBOARD COVER	COUVRE MARCHEPIED GAU.	LINKE FUSSBRETTDECKEL
72	12735402/0	4	VITE	SCREW	VIS	SCHRAUBE
81	•	1	COPERTURA SACCO	GRASS-CATCHER COVER	COUVRE-BAC	SACKKAPPE
	82110207/1		ROSSO	RED	ROUGE	ROT
	82110208/0		VERDE	GREEN	VERT	GRÜN
	82110235/0		ARANCIONE	ORANGE	ORANGE	DUNKELORANGE
	82110210/0		BLU	BLUE	BLEU	BLAU
	82110245/0		NERO	BLACK	NOIR	SCHWARZ
82	•	1	PIASTRINA	PLATE	PLAQUE	PLATTE
	25547016/2		ROSSA	RED	ROUGE	ROT
	25547015/0		VERDE	GREEN	VERT	GRÜN
	25547144/0		ARANCIONE	ORANGE	ORANGE	DUNKELORANGE
	25547024/0		BLU	BLUE	BLEU	BLAU
	25110301/0		NERO	BLACK	NOIR	SCHWARZ
83	12674701/0	2	VITE	SCREW	VIS	SCHRAUBE
84	12729601/1	4	VITE	SCREW	VIS	SCHRAUBE
85	12582101/0	2	GROWER	GROWER	GROWER	GROWER
86	12521331/0	6	RONDELLA	WASHER	RONDELLE	SCHEIBE
101	82869006/1	1	PROTEZIONE SILENZIATORE	MUFFLER PROTECTION	PROTECTION SILENCIEUX	AUSPUFFSCHUTZ
102	18566110/0	2	PUNTALE	CAP	BOUCHON	PFROPFEN
103	12734995/0	4	VITE	SCREW	VIS	SCHRAUBE
104	25547089/0	1	PIASTRINA DESTRA	RIGHT PLATE	PLAQUE DROITE	RECHTE PLATTE
105	25547091/0	1	PIASTRINA SINISTRA	LEFT PLATE	PLAQUE GAUCHE	LINKE PLATTE
106	12731580/0	4	VITE	SCREW	VIS	SCHRAUBE
			<b>Nei modelli con innesto delle lame a leva:</b>	<b>For models with engagement of the blades by lever:</b>	<b>Dans les modèles avec embrayage des lames à levier:</b>	<b>Bei Modellen mit Hebelschaltung der Messer:</b>
71	•	1	COPERTURA RUOTE	WHEELS COVER	COUVRE-ROUES	RADENKAPPE
	25109702/1		ROSSO	RED	ROUGE	ROT
	25109706/0		VERDE	GREEN	VERT	GRÜN
	25109727/1		ARANCIONE	ORANGE	ORANGE	DUNKELORANGE
	25109710/0		BLU	BLUE	BLEU	BLAU
71	•	1	COPERTURA RUOTE (hydro)	WHEELS COVER (hydro)	COUVRE-ROUES (hydro)	RADENKAPPE (hydro)
	25109700/1		ROSSO	RED	ROUGE	ROT
	25109704/0		VERDE	GREEN	VERT	GRÜN
	25109725/1		ARANCIONE	ORANGE	ORANGE	DUNKELORANGE
	25109708/0		BLU	BLUE	BLEU	BLAU
			<b>Nei modelli con innesto delle lame elettromagnetico:</b>	<b>For models with engagement of the blades by electromagnetic clutch:</b>	<b>Dans les modèles avec embrayage des lames électromagnétique:</b>	<b>Bei Modellen mit elektromagnetischer Schaltung der Messer:</b>
71	•	1	COPERTURA RUOTE	WHEELS COVER	COUVRE-ROUES	RADENKAPPE
	25109703/1		ROSSO	RED	ROUGE	ROT
	25109707/0		VERDE	GREEN	VERT	GRÜN
	25109728/1		ARANCIONE	ORANGE	ORANGE	DUNKELORANGE
	25109720/0		BLU	BLUE	BLEU	BLAU
71	•	1	COPERTURA RUOTE (hydro)	WHEELS COVER (hydro)	COUVRE-ROUES (hydro)	RADENKAPPE (hydro)
	25109701/1		ROSSO	RED	ROUGE	ROT
	25109705/0		VERDE	GREEN	VERT	GRÜN
	25109726/1		ARANCIONE	ORANGE	ORANGE	DUNKELORANGE
	25109709/0		BLU	BLUE	BLEU	BLAU

TC	TCP	TCR	TCB	TCX	TX
102	102 hydro	102 hydro	102 hydro	122 hydro	122 hydro

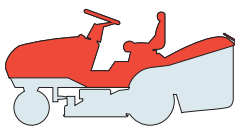

CARROZZERIA  
BODY  
CARROSSERIE  
KARROSSERIE

2006
002a.0
1 / 2

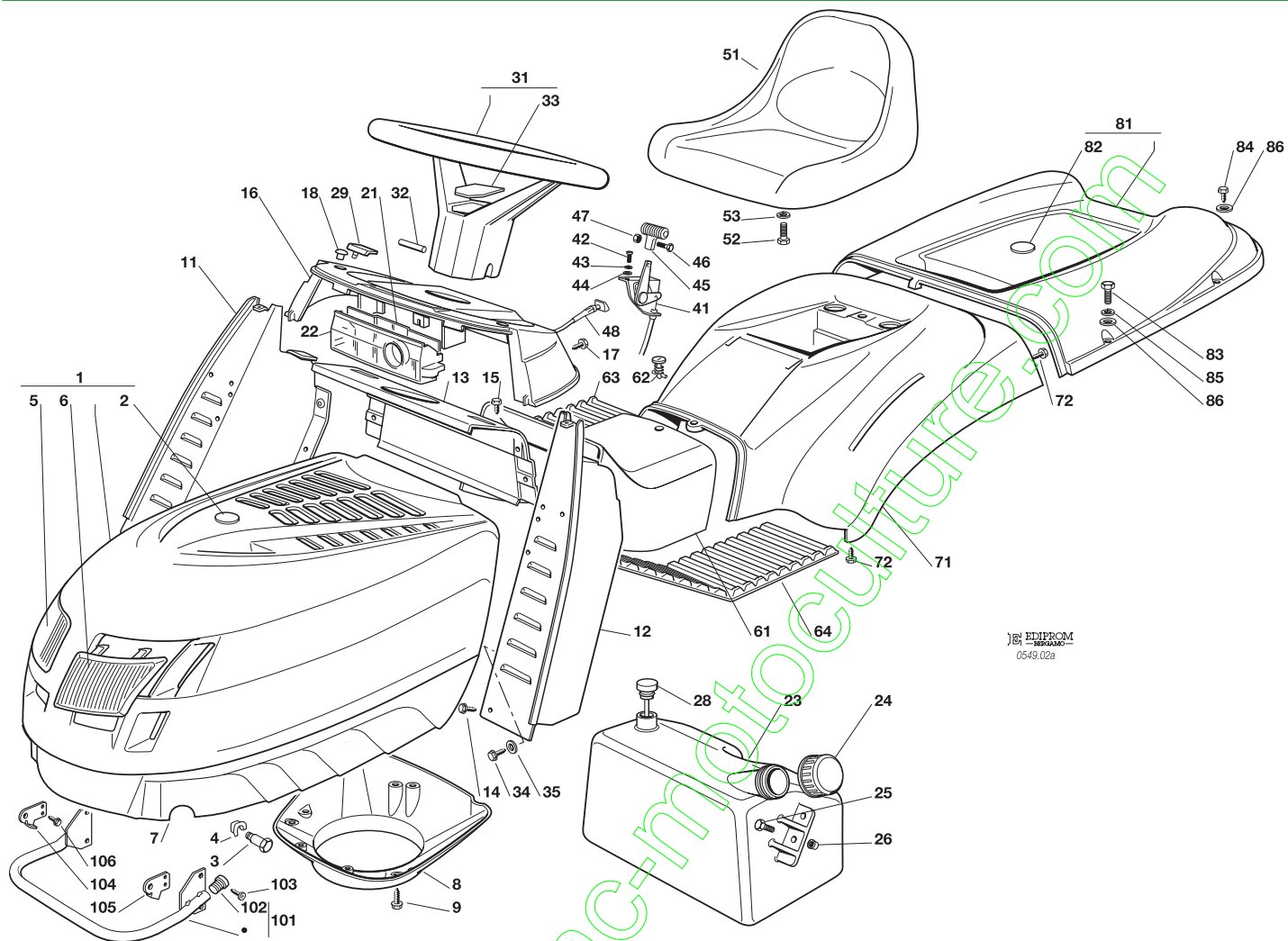

EDIPROM  
0549.02a

N.	CODE	Q.TY	DESCRIZIONE	DESCRIPTION	DESCRIPTION	BESCHREIBUNG
1	82076841/3 82076843/2 82076847/2	1	COFANO ROSSO VERDE BLU	ENGINE HOOD RED GREEN BLUE	CAPOT ROUGE VERT BLEU	HAUBESATZ ROT GRÜN BLAU
2	25547025/1 25547026/0 25547028/0	1	PIASTRINA ROSSA VERDE BLU	PLATE RED GREEN BLUE	PLAQUE ROUGE VERT BLEU	PLATTE ROT GRÜN BLAU
3	25510023/1	2	PERNO	PIN	PIVOT	BOLZEN
4	12436050/0	2	PIASTRINA	PLATE	PLAQUE	PLATTE
5	25410860/0	1	MASCHERINA DESTRA	RIGHT GRILL	PANNEAU DROITE	RECHTER SCHUTZ
6	25410861/0	1	MASCHERINA SINISTRA	LEFT GRILL	PANNEAU GAUCHE	LINKER SCHUTZ
7	25076808/0	1	COFANO INFERIORE	LOWER ENGINE HOOD	CAPOT INFÉRIEURE	UNTERHAUBESATZ
8	25108024/0 25108028/0	1	SEPARATORE ASPIRAZ. (780) SEPARAT. ASPIRAZ. (12849)	INTAKE SEPARATOR (780) INTAKE SEPARATOR (12849)	SEPARATEUR ASPIRAT. (780) SEPARATEUR ASP. (12849)	AUGENABSCHIEDER (780) AUGENABSCHIEDER (12849)
9	12728686/0	3	VITE	SCREW	VIS	SCHRAUBE
11	82785022/7	1	SUPP. CRUSCOTTO DESTRO	RIGHT DASHBOARD SUPP.	SUPPORT TABLEAU DROITE	RECHTER KONSOLEHALTER
12	82785021/6	1	SUPP. CRUSCOTTO SIN.	LEFT DASHBOARD SUPP.	SUPPORT TABLEAU GAUCHE	LINKER KONSOLEHALTER
13	82785137/0	1	SUPP. CRUSCOTTO CENTR.	CENTRAL DASHBOARD SUPP.	SUPPORT TABLEAU CENTR.	ZENTR. KONSOLE HALTER
14	12735110/0	2	VITE	SCREW	VIS	SCHRAUBE
15	12735110/0	4	VITE	SCREW	VIS	SCHRAUBE
17	12728440/0	4	VITE	SCREW	VIS	SCHRAUBE
18	25120200/0	2	TAPPO	PLUG	BOUCHON	PROPFEN
21	25600009/0	1	PROTEZIONE SCHEDA	CARD PROTECTION	PROTECTION DE CARTE	KARTESCHUTZ
22	25600051/0	1	PROTEZIONE SCHEDA	CARD PROTECTION	PROTECTION DE CARTE	KARTESCHUTZ
23	25735110/3 25735111/3	1	SERBATOIO (12879) SERBATOIO (480)	TANK (12879) TANK (480)	RESERVOIR (12879) RESERVOIR (480)	TANK (12879) TANK (480)
24	25795000/1	1	TAPPO	CAP	BOUCHON	TANKVERSCHLUSS
25	12789197/0	2	VITE	SCREW	VIS	SCHRAUBE
26	12500092/0	2	RIVETTO	RIVET	RIVET	SCHRAUBE
28	25290000/0	1	INDICATORE LIVELLO (480)	FUEL LEVEL INDICATOR (480)	INDICATEUR NIVEAU (480)	KRAFTSTOFFMESSER (480)
29	25260000/0	2	GOMMINO	GROMMET	PROTECTION	SCHUTZ



N.	CODE	Q.TY	DESCRIZIONE	DESCRIPTION	DESCRIPTION	BESCHREIBUNG
31	25961213/0	1	VOLANTE	STEERING WHEEL	VOLANT	LENKRAD
32	12620299/0	1	SPINA	PIN	GOUPILLE	STIFT
33	25120231/0	1	TAPPO	CAP	BOUCHON	STOPFEN
34	12731350/0	2	VITE	SCREW	VIS	SCHRAUBE
35	12521330/0	2	RONDELLA	WASHER	RONDELLE	SCHEIBE
41	82000200/1	1	ACCELERATORE (1230)	ACCELERATOR (1230)	ACCELERATEUR (1230)	GAS ZUG (1230)
	82000201/2	1	ACCELERATORE (478)	ACCELERATOR (478)	ACCELERATEUR (478)	GAS ZUG (478)
	82000204/1	1	ACCELERATORE (0)	ACCELERATOR (0)	ACCELERATEUR (0)	GAS ZUG (0)
42	12788512/0	2	VITE	SCREW	VIS	SCHRAUBE
43	12581200/0	2	GROWER	GROWER	GROWER	GROWER
44	12521310/0	2	RONDELLA	WASHER	RONDELLE	SCHEIBE
45	25394501/0	1	MANOPOLINA	HANDLE	POIGNE	GRIF
46	12726388/0	1	VITE	SCREW	VIS	SCHRAUBE
47	12290800/0	1	DADO	NUT	ECROU	MUTTER
48	25090001/2	1	COMANDO STARTER (478)	CHOKE CONTROL (478)	COMMANDE STARTER (478)	STARTER BETAETIGUNG (478)
	25090004/0	1	COMANDO STARTER (0)	CHOKE CONTROL (0)	COMMANDE STARTER (0)	STARTER BETAETIGUNG (0)
51	25722451/2	1	SEDILE	SEAT	SIEGE	SITZ
52	12793101/0	4	VITE	SCREW	VIS	SCHRAUBE
53	12583500/0	4	GROWER	GROWER	GROWER	GROWER
61	25110136/1	1	COPERTURA CENTRALE ROSSO	COVER RED	COUVRE ROUGE	KAPPE ROT
	25110135/0		VERDE	GREEN	VERT	GRÜN
	25110132/0		BLU	BLUE	BLEU	BLAU
61	25110239/1	1	COPERTURA CENTR. (hydro) ROSSO	COVER (hydro) RED	COUVRE (hydro) ROUGE	KAPPE (hydro) ROT
	25110240/0		VERDE	GREEN	VERT	GRÜN
	25110242/0		BLU	BLUE	BLEU	BLAU
62	25580020/0	1	PERNO	PIVOT	GOUJON	STIFT
63	25110270/0	1	COPRIPEDANA DESTRA	RIGHT FOOTBOARD COVER	COUVRE MARCHEPIED DRO.	RECHTE FUSSBRETTDECKEL
64	25110260/2	1	COPRIPEDANA SINISTRA	LEFT FOOTBOARD COVER	COUVRE MARCHEPIED GAU.	LINKE FUSSBRETTDECKEL
72	12735402/0	4	VITE	SCREW	VIS	SCHRAUBE
81	82110200/1	1	COPERTURA SACCO ROSSO	GRASS-CATCHER COVER RED	COUVRE-BAC ROUGE	SACKKAPPE ROT
	82110201/0		VERDE	GREEN	VERT	GRÜN
	82110203/0		BLU	BLUE	BLEU	BLAU
82	25547025/1	1	PIASTRINA ROSSA	PLATE RED	PLAQUE ROUGE	PLATTE ROT
	25547026/0		VERDE	GREEN	VERT	GRÜN
	25547028/0		BLU	BLUE	BLEU	BLAU
83	12674701/0	2	VITE	SCREW	VIS	SCHRAUBE
84	12729601/1	4	VITE	SCREW	VIS	SCHRAUBE
85	12582101/0	2	GROWER	GROWER	GROWER	GROWER
86	12521331/0	6	RONDELLA	WASHER	RONDELLE	SCHEIBE
101	82869006/1	1	PROTEZIONE SILENZIATORE	MUFFLER PROTECTION	PROTECTION SILENCIEUX	AUSPUFFSCHUTZ
102	18566110/0	2	PUNTALE	CAP	BOUCHON	PFROPFEN
103	12734995/0	4	VITE	SCREW	VIS	SCHRAUBE
104	25547089/0	1	PIASTRINA DESTRA	RIGHT PLATE	PLAQUE DROITE	RECHTE PLATTE
105	25547091/0	1	PIASTRINA SINISTRA	LEFT PLATE	PLAQUE GAUCHE	LINKE PLATTE
106	12731580/0	4	VITE	SCREW	VIS	SCHRAUBE

**Nei modelli con innesto delle lame a leva:**

**For models with engagement of the blades by lever:**

**Dans les modèles avec embrayage des lames à levier:**

**Bei Modellen mit Hebelschaltung der Messer:**

16	25120153/1	1	CRUSCOTTO	DASHBOARD	TABLEAU DE BORD	KONSOLE
71	25109702/1	1	COPERTURA RUOTE ROSSO	WHEELS COVER RED	COUVRE-ROUES ROUGE	RADENKAPPE ROT
	25109706/0		VERDE	GREEN	VERT	GRÜN
	25109710/0		BLU	BLUE	BLEU	BLAU
71	25109700/1	1	COPERTURA RUOTE (hydro) ROSSO	WHEELS COVER (hydro) RED	COUVRE-ROUES (hydro) ROUGE	RADENKAPPE (hydro) ROT
	25109704/0		VERDE	GREEN	VERT	GRÜN
	25109708/0		BLU	BLUE	BLEU	BLAU

**Nei modelli con innesto delle lame elettromagnetico:**

**For models with engagement of the blades by electromagnetic clutch:**

**Dans les modèles avec embrayage des lames électromagnétique:**

**Bei Modellen mit elektromagnetischer Schaltung der Messer:**

16	25120171/1	1	CRUSCOTTO	DASHBOARD	TABLEAU DE BORD	KONSOLE
71	25109703/1	1	COPERTURA RUOTE ROSSO	WHEELS COVER RED	COUVRE-ROUES ROUGE	RADENKAPPE ROT
	25109707/0		VERDE	GREEN	VERT	GRÜN
	25109720/0		BLU	BLUE	BLEU	BLAU
71	25109701/1	1	COPERTURA RUOTE (hydro) ROSSO	WHEELS COVER (hydro) RED	COUVRE-ROUES (hydro) ROUGE	RADENKAPPE (hydro) ROT
	25109705/0		VERDE	GREEN	VERT	GRÜN
	25109709/0		BLU	BLUE	BLEU	BLAU

TC	TCP	TCR	TCB	TCX	TX
102	102 hydro	122 hydro			

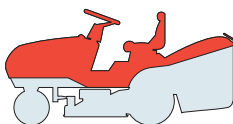

CARROZZERIA  
BODY  
CARROSSERIE  
KARROSSERIE

2006
002b.0
1 / 2

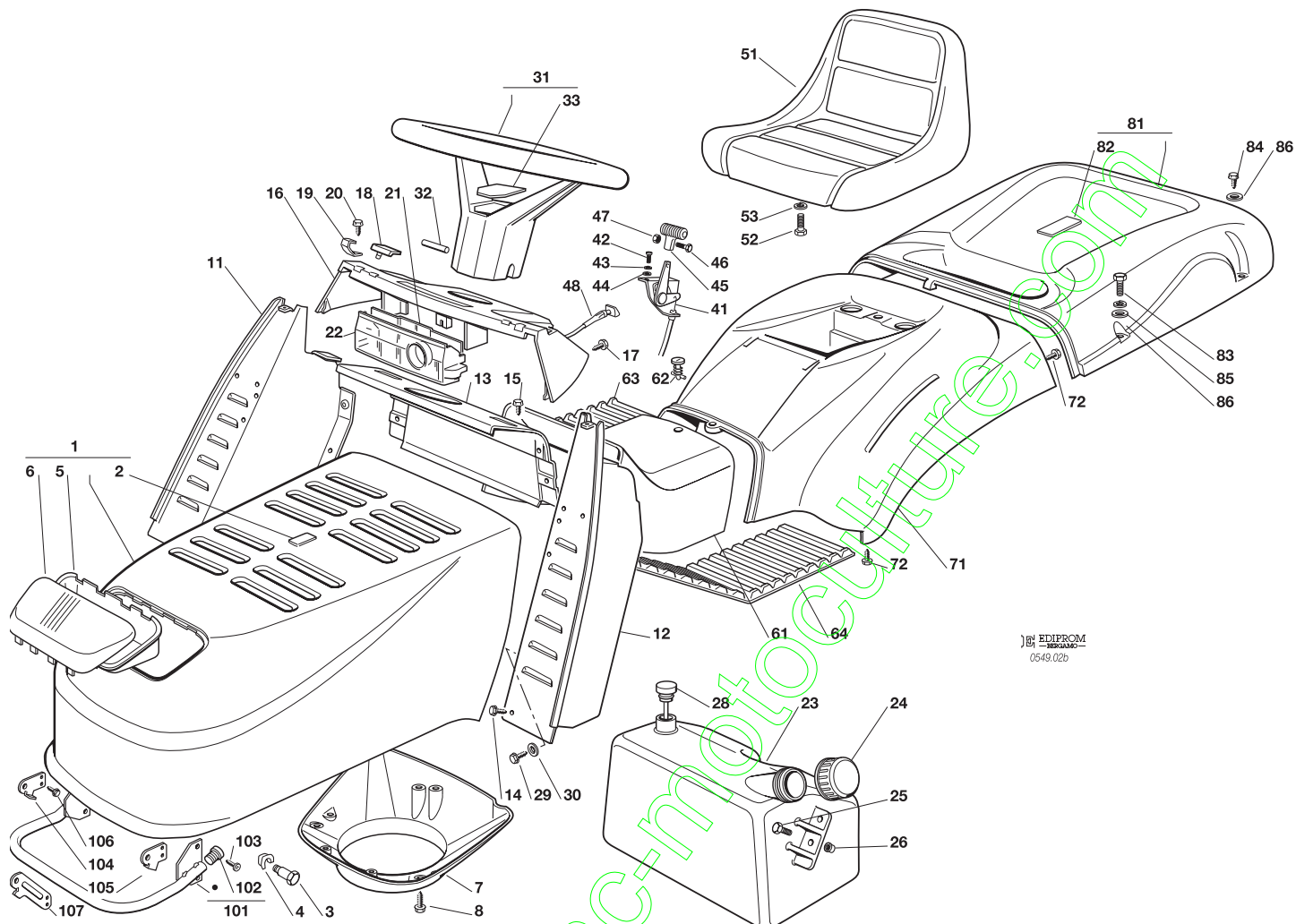

EDIPROM  
0549.02b

N.	CODE	Q.TY	DESCRIZIONE	DESCRIPTION	DESCRIPTION	BESCHREIBUNG
1	82076817/2 82076818/1 82076831/1	1	COFANO ROSSO VERDE BLU	ENGINE HOOD RED GREEN BLUE	CAPOT ROUGE VERT BLEU	HAUBESATZ ROT GRÜN BLAU
2	25547016/2 25547015/0 25547024/0	1	PIASTRINA ROSSA VERDE BLU	PLATE RED GREEN BLUE	PLAQUE ROUGE VERT BLEU	PLATTE ROT GRÜN BLAU
3	25510039/0	2	PERNO	PIN	PIVOT	BOLZEN
4	12436050/0	2	PIASTRINA	PLATE	PLAQUE	PLATTE
5	25485001/0	1	PARABOLA FARI	LIGHTS PARABOLA	PARABOLE	SCHEINWERFERPARABEL
6	25410865/0	1	MASCHERINA	GRILL	PANNEAU	SCHUTZ
7	25108024/0 25108028/0	1	SEPARATORE ASPIRAZ. (07) SEPARAT. ASPIRAZ. (100)	INTAKE SEPARATOR (07) INTAKE SEPARATOR (100)	SEPARATEUR ASPIRAT. (07) SEPARATEUR ASPIR. (100)	AUGENABSCHIEDER (07) AUGENABSCHIEDER (100)
8	12728686/0	3	VITE	SCREW	VIS	SCHRAUBE
11	82785022/7	1	SUPP. CRUSCOTTO DESTRO	RIGHT DASHBOARD SUPP.	SUPPORT TABLEAU DROITE	RECHTER KONSOLEHALTER
12	82785021/6	1	SUPP. CRUSCOTTO SIN.	LEFT DASHBOARD SUPP.	SUPPORT TABLEAU GAUCHE	LINKER KONSOLEHALTER
13	82785137/0	1	SUPP. CRUSCOTTO CENTR.	CENTRAL DASHBOARD SUPP.	SUPPORT TABLEAU CENTR.	ZENTR. KONSOLE HALTER
14	12735110/0	2	VITE	SCREW	VIS	SCHRAUBE
15	12735110/0	4	VITE	SCREW	VIS	SCHRAUBE
16	25120152/1	1	CRUSCOTTO	DASHBOARD	TABEUAU DE BORD	KONSOLE
17	12728440/0	4	VITE	SCREW	VIS	SCHRAUBE
18	25260000/0	2	GOMMINO	GROMMET	PROTECTION	SCHUTZ
19	25430215/0	2	MOLLA AGGANCI	COUPLING SPRING	RESSORT ACCROCHAGE	KUPPLUNGSFEDER
20	12728440/0	2	VITE	SCREW	VIS	SCHRAUBE
21	25600007/0	1	PROTEZIONE SCHEDA	CARD PROTECTION	PROTECTION DE CARTE	KARTESCHUTZ
22	25600005/0	1	PROTEZIONE SCHEDA	CARD PROTECTION	PROTECTION DE CARTE	KARTESCHUTZ
23	25735110/3 25735111/3	1	SERBATOIO (100000) SERBATOIO (4)	TANK (100000) TANK (4)	RESERVOIR (100000) RESERVOIR (4)	TANK (100000) TANK (4)
24	25795000/1	1	TAPPO	CAP	BOUCHON	TANKVERSCHLUSS
25	12789197/0	2	VITE	SCREW	VIS	SCHRAUBE
26	12500092/0	2	RIVETTO	RIVET	RIVET	NIET
28	25290000/0	1	INDICATORE LIVELLO (4)	FUEL LEVEL INDICATOR (4)	INDICATEUR NIVEAU (4)	KRAFTSTOFFMESSER (4)





N.	CODE	Q.TY	DESCRIZIONE	DESCRIPTION	DESCRIPTION	BESCHREIBUNG
29	12731350/0	2	VITE	SCREW	VIS	SCHRAUBE
30	12521330/0	2	RONDELLA	WASHER	RONDELLE	SCHEIBE
31	25961213/0	1	VOLANTE	STEERING WHEEL	VOLANT	LENKRAD
32	12620299/0	1	SPINA	PIN	GOUPILLE	STIFT
33	25120231/0	1	TAPPO	CAP	BOUCHON	STOPFEN
41	82000200/1	1	ACCELERATORE (1236)	ACCELERATOR (1236)	ACCELERATEUR (1236)	GAS ZUG (1236)
	82000201/2	1	ACCELERATORE (47)	ACCELERATOR (47)	ACCELERATEUR (47)	GAS ZUG (47)
42	12788512/0	2	VITE	SCREW	VIS	SCHRAUBE
43	12581200/0	2	GROWER	GROWER	GROWER	GROWER
44	12521310/0	2	RONDELLA	WASHER	RONDELLE	SCHEIBE
45	25394501/0	1	MANOPOLINA	HANDLE	POIGNE	GRIFF
46	12726388/0	1	VITE	SCREW	VIS	SCHRAUBE
47	12290800/0	1	DADO	NUT	ECROU	MUTTER
48	25090001/2	1	COMANDO STARTER (47)	CHOKE CONTROL (47)	COMMANDE STARTER (47)	STARTER BETAETIGUNG (47)
51	25722450/1	1	SEDILE	SEAT	SIEGE	SITZ
52	12793101/0	4	VITE	SCREW	VIS	SCHRAUBE
53	12583500/0	4	GROWER	GROWER	GROWER	GROWER
61	25110136/1	1	ROSSO	RED	ROUGE	ROT
	25110135/0		VERDE	GREEN	VERT	GRÜN
	25110132/0		BLU	BLUE	BLEU	BLAU
61	25110239/1	1	COPERTURA CENTR. (hydro)	COVER (hydro)	COUVRE (hydro)	KAPPE (hydro)
	25110240/0		ROSSO	RED	ROUGE	ROT
	25110240/0		VERDE	GREEN	VERT	GRÜN
	25110242/0		BLU	BLUE	BLEU	BLAU
62	25580020/0	1	PERNO	PIVOT	GOUJON	STIFT
63	25110270/0	1	COPRIPEDANA DESTRA	RIGHT FOOTBOARD COVER	COUVRE MARCHEPIED DRO.	RECHTE FUSSBRETTDECKEL
64	25110260/2	1	COPRIPEDANA SINISTRA	LEFT FOOTBOARD COVER	COUVRE MARCHEPIED GAU.	LINKE FUSSBRETTDECKEL
72	12735402/0	4	VITE	SCREW	VIS	SCHRAUBE
81	82110207/1	1	ROSSO	RED	ROUGE	ROT
	82110208/0		VERDE	GREEN	VERT	GRÜN
	82110210/0		BLU	BLUE	BLEU	BLAU
	82110245/0		NERO	BLACK	NOIR	SCHWARZ
82	25547016/2	1	PIASTRINA	PLATE	PLAQUE	PLATTE
	25547015/0		ROSSA	RED	ROUGE	ROT
	25547024/0		VERDE	GREEN	VERT	GRÜN
	25110301/0		BLU	BLUE	BLEU	BLAU
	25110301/0		NERO	BLACK	NOIR	SCHWARZ
83	12674701/0	2	VITE	SCREW	VIS	SCHRAUBE
84	12729601/1	4	VITE	SCREW	VIS	SCHRAUBE
85	12582101/0	2	GROWER	GROWER	GROWER	GROWER
86	12521331/0	6	RONDELLA	WASHER	RONDELLE	SCHEIBE
101	82869006/1	1	PROTEZIONE SILENZIATORE	MUFFLER PROTECTION	PROTECTION SILENCIEUX	AUSPUFFSCHUTZ
101	82869015/0	1	PROTEZIONE SILENZIATORE 18 HP B&S	MUFFLER PROTECTION 18 HP B&S	PROTECTION SILENCIEUX 18 HP B&S	AUSPUFFSCHUTZ 18 HP B&S
102	18566110/0	2	PUNTALE	CAP	BOUCHON	PFROPFEN
103	12734995/0	4	VITE	SCREW	VIS	SCHRAUBE
104	25547089/0	1	PIASTRINA DESTRA	RIGHT PLATE	PLAQUE DROITE	RECHTE PLATTE
105	25547091/0	1	PIASTRINA SINISTRA	LEFT PLATE	PLAQUE GAUCHE	LINKE PLATTE
106	12731580/0	4	VITE	SCREW	VIS	SCHRAUBE
107	25547099/0	2	PIASTRINA 18 HP B&S	PLATE 18 HP B&S	PLAQUE 18 HP B&S	PLATTE 18 HP B&S
			<b>Nei modelli con innesto delle lame a leva:</b>	<b>For models with engagement of the blades by lever:</b>	<b>Dans les modèles avec em-brayage des lames à levier:</b>	<b>Bei Modellen mit Hebelschaltung der Messer:</b>
71	25109702/1	1	ROSSO	RED	ROUGE	ROT
	25109706/0		VERDE	GREEN	VERT	GRÜN
	25109710/0		BLU	BLUE	BLEU	BLAU
71	25109700/1	1	ROSSO	RED	ROUGE	ROT
	25109704/0		VERDE	GREEN	VERT	GRÜN
	25109708/0		BLU	BLUE	BLEU	BLAU
			<b>Nei modelli con innesto delle lame elettromagnetico:</b>	<b>For models with engagement of the blades by electromagnetic clutch:</b>	<b>Dans les modèles avec embrayage des lames électromagnétique:</b>	<b>Bei Modellen mit elektro-magnetischer Schaltung der Messer:</b>
71	25109703/1	1	ROSSO	RED	ROUGE	ROT
	25109707/0		VERDE	GREEN	VERT	GRÜN
	25109720/0		BLU	BLUE	BLEU	BLAU
71	25109701/1	1	ROSSO	RED	ROUGE	ROT
	25109705/0		VERDE	GREEN	VERT	GRÜN
	25109709/0		BLU	BLUE	BLEU	BLAU

TC	TCP	TCR	TCB	TCX	TX
102	102 hydro	102 hydro	102 hydro	122 hydro	122 hydro

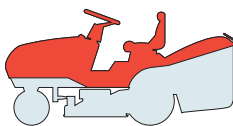

CARROZZERIA  
BODY  
CARROSSERIE  
KARROSSERIE

2006
002c.0
1 / 2

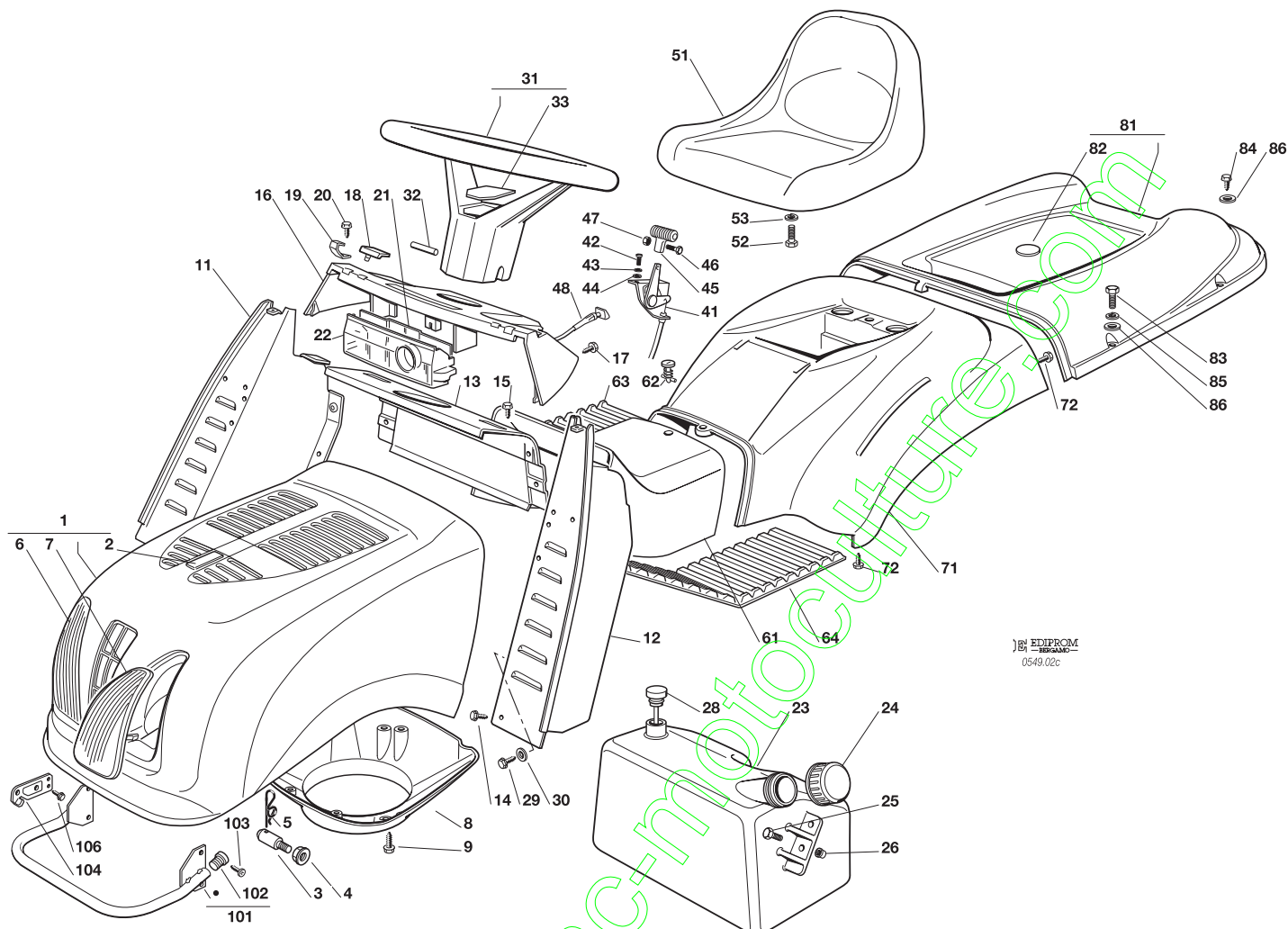

EDIPROM  
0549.02c

N.	CODE	Q.TY	DESCRIZIONE	DESCRIPTION	DESCRIPTION	BESCHREIBUNG
----	------	------	-------------	-------------	-------------	--------------

1	82076917/1 82076918/0 82076919/0	1	COFANO ROSSO VERDE BLU	ENGINE HOOD RED GREEN BLUE	CAPOT ROUGE VERT BLEU	HAUBESATZ ROT GRÜN BLAU
2	25547016/2 25547015/0 25547024/0	1	PIASTRINA ROSSA VERDE BLU	PLATE RED GREEN BLUE	PLAQUE ROUGE VERT BLEU	PLATTE ROT GRÜN BLAU
3	25510068/0	2	PERNO	PIN	PIVOT	BOLZEN
4	12293201/0	2	DADO	NUT	ECROU	MUTTER
5	24487998/0	1	COPPIGLIA	COTTER PIN	GOUPILLE	SPLIT
6	25410869/0	1	MASCHERINA SINISTRA	LEFT GRILL	PANNEAU GAUCHE	LINKE SCHUTZ
7	25410868/0	1	MASCHERINA DESTRA	RIGHT GRILL	PANNEAU DROITE	RECHTE SCHUTZ
8	25108024/0 25108028/0	1	SEPARATORE ASPIRAZ. (70) SEPARAT. ASPIR. (120000)	INTAKE SEPARATOR (70) INTAKE SEPARATOR (120000)	SEPARATEUR ASPIRAT. (70) SEPARATEUR ASPIR. (120000)	AUGENABSCHIEDER (70) AUGENABSCHIEDER (120000)
9	12728686/0	3	VITE	SCREW	VIS	SCHRAUBE
11	82785022/7	1	SUPP. CRUSCOTTO DESTRO	RIGHT DASHBOARD SUPP.	SUPPORT TABLEAU DROITE	RECHTER KONSOLEHALTER
12	82785021/6	1	SUPP. CRUSCOTTO SIN.	LEFT DASHBOARD SUPP.	SUPPORT TABLEAU GAUCHE	LINKER KONSOLEHALTER
13	82785137/0	1	SUPP. CRUSCOTTO CENTR.	CENTRAL DASHBOARD SUPP.	SUPPORT TABLEAU CENTR.	ZENTR. KONSOLE HALTER
14	12735110/0	2	VITE	SCREW	VIS	SCHRAUBE
15	12735110/0	4	VITE	SCREW	VIS	SCHRAUBE
16	25120152/1	1	CRUSCOTTO	DASHBOARD	TABLEAU DE BORD	KONSOLE
17	12728440/0	4	VITE	SCREW	VIS	SCHRAUBE
18	25260000/0	2	GOMMINO	GROMMET	PROTECTION	SCHUTZ
19	25430215/0	2	MOLLA AGGANCIO	COUPLING SPRING	RESSORT ACCROCHAGE	KUPPLUNGSFEDER
20	12728440/0	2	VITE	SCREW	VIS	SCHRAUBE
21	25600007/0	1	PROTEZIONE SCHEDA	CARD PROTECTION	PROTECTION DE CARTE	KARTESCHUTZ
22	25600005/0	1	PROTEZIONE SCHEDA	CARD PROTECTION	PROTECTION DE CARTE	KARTESCHUTZ
23	25735110/3 25735111/3	1	SERBATOIO (120000) SERBATOIO (4000)	TANK (120000) TANK (4000)	RESERVOIR (120000) RESERVOIR (4000)	TANK (120000) TANK (4000)
24	25795000/1	1	TAPPO	CAP	BOUCHON	TANKVERSCHLUSS
25	12789197/0	2	VITE	SCREW	VIS	SCHRAUBE
26	12500092/0	2	RIVETTO	RIVET	RIVET	NIET
28	25290000/0	1	INDICATORE LIVELLO (4000)	FUEL LEVEL INDICATOR (4000)	INDICATEUR NIVEAU (4000)	KRAFTSTOFFMESSER (4000)



N.	CODE	Q.TY	DESCRIZIONE	DESCRIPTION	DESCRIPTION	BESCHREIBUNG
29	12731350/0	2	VITE	SCREW	VIS	SCHRAUBE
30	12521330/0	2	RONDELLA	WASHER	RONDELLE	SCHEIBE
31	25961213/0	1	VOLANTE	STEERING WHEEL	VOLANT	LENKRAD
32	12620299/0	1	SPINA	PIN	GOUPILLE	STIFT
33	25120231/0	1	TAPPO	CAP	BOUCHON	STOPFEN
41	82000200/1	1	ACCELERATORE (1230)	ACCELERATOR (1230)	ACCELERATEUR (1230)	GAS ZUG (1230)
	82000201/2	1	ACCELERATORE (470)	ACCELERATOR (470)	ACCELERATEUR (470)	GAS ZUG (470)
	82000204/1	1	ACCELERATORE (10)	ACCELERATOR (10)	ACCELERATEUR (10)	GAS-ZUG (10)
42	12788512/0	2	VITE	SCREW	VIS	SCHRAUBE
43	12581200/0	2	GROWER	GROWER	GROWER	GROWER
44	12521310/0	2	RONDELLA	WASHER	RONDELLE	SCHEIBE
45	25394501/0	1	MANOPOLINA	HANDLE	POIGNE	GRIF
46	12726388/0	1	VITE	SCREW	VIS	SCHRAUBE
47	12290800/0	1	DADO	NUT	ECROU	MUTTER
48	25090001/2	1	COMANDO STARTER (470)	CHOKE CONTROL (470)	COMMANDE STARTER (470)	STARTER BETAETIGUNG (470)
	25090004/0	1	COMANDO STARTER (10)	CHOKE CONTROL (10)	COMMANDE STARTER (10)	STARTER BETAETIGUNG (10)
51	25722451/2	1	SEDILE	SEAT	SIEGE	SITZ
52	12793101/0	4	VITE	SCREW	VIS	SCHRAUBE
53	12583500/0	4	GROWER	GROWER	GROWER	GROWER
61	25110136/1	1	COPERTURA CENTRALE ROSSO	COVER RED	COUVRE ROUGE	KAPPE ROT
	25110135/0		VERDE	GREEN	VERT	GRÜN
	25110132/0		BLU	BLUE	BLEU	BLAU
61	25110239/1	1	COPERTURA CENTR. (hydro) ROSSO	COVER (hydro) RED	COUVRE (hydro) ROUGE	KAPPE (hydro) ROT
	25110240/0		VERDE	GREEN	VERT	GRÜN
	25110242/0		BLU	BLUE	BLEU	BLAU
62	25580020/0	1	PERNO	PIVOT	GOUJON	STIFT
63	25110270/0	1	COPRIPEDANA DESTRA	RIGHT FOOTBOARDCOVER	COUVRE MARCHEPIED DRO.	RECHTE FUSSBRETTDECKEL
64	25110260/2	1	COPRIPEDANA SINISTRA	LEFT FOOTBOARD COVER	COUVRE MARCHEPIED GAU.	LINKE FUSSBRETTDECKEL
72	12735402/0	4	VITE	SCREW	VIS	SCHRAUBE
81	82110200/1	1	COPERTURA SACCO ROSSO	GRASS-CATCHER COVER RED	COUVRE-BAC ROUGE	SACKKAPPE ROT
	82110201/0		VERDE	GREEN	VERT	GRÜN
	82110203/0		BLU	BLUE	BLEU	BLAU
82	25547025/1	1	PIASTRINA ROSSA	PLATE RED	PLAQUE ROUGE	PLATTE ROT
	25547026/0		VERDE	GREEN	VERT	GRÜN
	25547028/0		BLU	BLUE	BLEU	BLAU
83	12674701/0	2	VITE	SCREW	VIS	SCHRAUBE
84	12729601/1	4	VITE	SCREW	VIS	SCHRAUBE
85	12582101/0	2	GROWER	GROWER	GROWER	GROWER
86	12521331/0	6	RONDELLA	WASHER	RONDELLE	SCHEIBE
101	82869006/1	1	PROTEZIONE SILENZIATORE	MUFFLER PROTECTION	PROTECTION SILENCIEUX	AUSPUFFSCHUTZ
102	18566110/0	2	PUNTALE	CAP	BOUCHON	PFROPFEN
103	12734995/0	4	VITE	SCREW	VIS	SCHRAUBE
104	25547109/1	2	PIASTRINA	PLATE	PLAQUE	PLATTE
106	12731580/0	4	VITE	SCREW	VIS	SCHRAUBE

**Nei modelli con innesto delle lame a leva:**

**For models with engagement of the blades by lever:**

**Dans les modèles avec em-brayage des lames à levier:**

**Bei Modellen mit Hebelschaltung der Messer:**

71	25109702/1	1	COPERTURA RUOTE ROSSO	WHEELS COVER RED	COUVRE-ROUES ROUGE	RADENKAPPE ROT
	25109706/0		VERDE	GREEN	VERT	GRÜN
	25109710/0		BLU	BLUE	BLEU	BLAU
71	25109700/1	1	COPERTURA RUOTE (hydro) ROSSO	WHEELS COVER (hydro) RED	COUVRE-ROUES (hydro) ROUGE	RADENKAPPE (hydro) ROT
	25109704/0		VERDE	GREEN	VERT	GRÜN
	25109708/0		BLU	BLUE	BLEU	BLAU

**Nei modelli con innesto delle lame elettromagnetico:**

**For models with engagement of the blades by electromagnetic clutch:**

**Dans les modèles avec embrayage des lames électromagnétique:**

**Bei Modellen mit elektro-magnetischer Schaltung der Messer:**

71	25109703/1	1	COPERTURA RUOTE ROSSO	WHEELS COVER RED	COUVRE-ROUES ROUGE	RADENKAPPE ROT
	25109707/0		VERDE	GREEN	VERT	GRÜN
	25109720/0		BLU	BLUE	BLEU	BLAU
71	25109701/1	1	COPERTURA RUOTE (hydro) ROSSO	WHEELS COVER (hydro) RED	COUVRE-ROUES (hydro) ROUGE	RADENKAPPE (hydro) ROT
	25109705/0		VERDE	GREEN	VERT	GRÜN
	25109709/0		BLU	BLUE	BLEU	BLAU

TC	TCP	TCR	TCB	TCX	TX
102	102 hydro	102 hydro	102 hydro	122 hydro	122 hydro

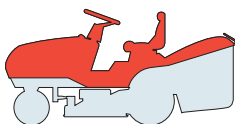

CARROZZERIA  
BODY  
CARROSSERIE  
KARROSSERIE

2006
002d.0
1 / 2

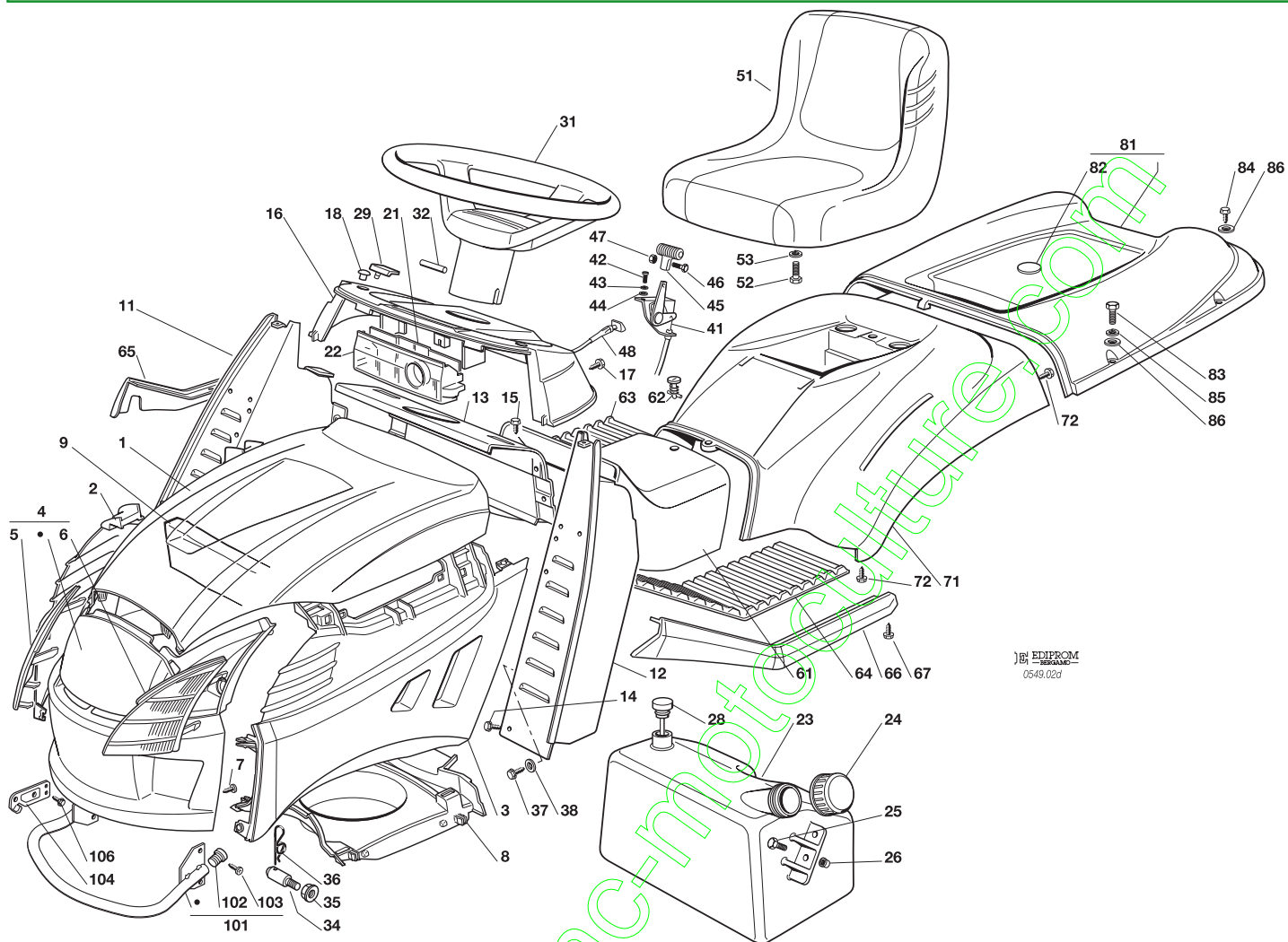

EDIPROM  
0549.020

N.	CODE	Q.TY	DESCRIZIONE	DESCRIPTION	DESCRIPTION	BESCHREIBUNG
----	------	------	-------------	-------------	-------------	--------------

1	25076858/0	1	COFANO SUPERIORE	UPPER ENGINE HOOD	CAPOT SUPERIEURE	OBERHAUBESATZ
2	25207120/0	1	COFANO DX	HOOD, RIGHT	CAPOT DROITE	RECHTE HAUBE
3	25207121/0	1	COFANO SX	HOOD, LEFT	CAPOT GAUCHE	LINKE HAUBE
4	82394607/0	1	COFANO FRONTALE	HOOD, FRONT	CAPOT AVANT	VORDE HAUBE
5	25410874/0	1	MASCHERINA DESTRA	RIGHT GRILL	PANNEAU DROITE	RECHTE SCHUTZ
6	25410875/0	1	MASCHERINA SINISTRA	LEFT GRILL	PANNEAU GAUCHE	LINKE SCHUTZ
7	12735405/0	6	VITE	SCREW	VIS	SCHRAUBE
8	25108025/0	1	CONVOGLIATORE	CONVEYOR	CONVOYEUR	KONVEYOR
9	25730016/0	1	SEPARATORE ASPIR. (70)	INTAKE SEPARATOR (70)	SEPARATEUR ASPIR. (70)	AUGENABSCHIEDER (70)
11	82785022/7	1	SUPP. CRUSCOTTO DESTRO	RIGHT DASHBOARD SUPP.	SUPPORT TABLEAU DROITE	RECHTER KONSOLEHALTER
12	82785021/6	1	SUPP. CRUSCOTTO SIN.	LEFT DASHBOARD SUPP.	SUPPORT TABLEAU GAUCHE	LINKER KONSOLEHALTER
13	82785137/0	1	SUPP. CRUSCOTTO CENTR.	CENTRAL DASHBOARD SUPP.	SUPPORT TABLEAU CENTR.	ZENTR. KONSOLE HALTER
14	12735110/0	2	VITE	SCREW	VIS	SCHRAUBE
15	12735110/0	4	VITE	SCREW	VIS	SCHRAUBE
17	12728440/0	4	VITE	SCREW	VIS	SCHRAUBE
18	25120200/0	2	TAPPO	PLUG	BOUCHON	PROPFEN
21	25600009/0	1	PROTEZIONE SCHEDA	CARD PROTECTION	PROTECTION DE CARTE	KARTESCHUTZ
22	25600005/0	1	PROTEZIONE SCHEDA	CARD PROTECTION	PROTECTION DE CARTE	KARTESCHUTZ
23	25735110/3	1	SERBATOIO (12000)	TANK (12000)	RESERVOIR (12000)	TANK (12000)
	25735111/3	1	SERBATOIO (40)	TANK (40)	RESERVOIR (40)	TANK (40)
24	25795000/1	1	TAPPO	CAP	BOUCHON	TANKVERSCHLUSS
25	12789197/0	2	VITE	SCREW	VIS	SCHRAUBE
26	12500092/0	2	RIVETTO	RIVET	RIVET	NIET
28	25290000/0	1	INDICATORE LIVELLO (40)	FUEL LEVEL INDICATOR (40)	INDICATEUR NIVEAU (40)	KRAFTSTOFFMESSER (40)
29	25260000/0	2	GOMMINO	GROMMET	PROTECTION	SCHUTZ
31	25961214/0	1	VOLANTE	STEERING WHEEL	VOLANT	LENKRAD







N.	CODE	Q.TY	DESCRIZIONE	DESCRIPTION	DESCRIPTION	BESCHREIBUNG
32	12620299/0	1	SPINA	PIN	GOUPILLE	STIFT
34	25510068/0	2	PERNO	PIN	PIVOT	BOLZEN
35	12293201/0	2	DADO	NUT	ECROU	MUTTER
36	24487998/0	1	COPPIGLIA	COTTER PIN	GOUPILLE	SPLIT
37	12731350/0	2	VITE	SCREW	VIS	SCHRAUBE
38	12521330/0	2	RONDELLA	WASHER	RONDELLE	SCHEIBE
41	82000200/1	1	ACCELERATORE (1235)	ACCELERATOR (1235)	ACCELERATEUR (1235)	GAS-ZUG (1235)
	82000201/2	1	ACCELERATORE (478)	ACCELERATOR (478)	ACCELERATEUR (478)	GAS-ZUG (478)
42	12788512/0	2	VITE	SCREW	VIS	SCHRAUBE
43	12581200/0	2	GROWER	GROWER	GROWER	GROWER
44	12521310/0	2	RONDELLA	WASHER	RONDELLE	SCHEIBE
45	25394501/0	1	MANOPOLINA	HANDLE	POIGNE	GRIF
46	12726388/0	1	VITE	SCREW	VIS	SCHRAUBE
47	12290800/0	1	DADO	NUT	ECROU	MUTTER
48	25090001/2	1	COMANDO STARTER (478)	CHOKE CONTROL (478)	COMMANDE STARTER (478)	STARTER BETAETIGUNG (478)
51	25722459/0	1	SEDILE	SEAT	SIEGE	SITZ
52	12793101/0	4	VITE	SCREW	VIS	SCHRAUBE
53	12583500/0	4	GROWER	GROWER	GROWER	GROWER
61	25110136/1	1	COPERTURA CENTRALE	COVER	COUVRE	KAPPE
61	25110239/1	1	COPERTURA CENTR. (hydro)	COVER (hydro)	COUVRE (hydro)	KAPPE (hydro)
62	25580020/0	1	PERNO	PIVOT	GOIJON	STIFT
63	25110278/1	1	COPRIPEDANA DESTRA	RIGHT FOOTBOARDCOVER	COUVRE MARCHEPIED DRO.	RECHTE FUSSBRETTDECKEL
64	25110279/0	1	COPRIPEDANA SINISTRA	LEFT FOOTBOARD COVER	COUVRE MARCHEPIED GAU.	LINKE FUSSBRETTDECKEL
65	25599000/0	1	PROFILO DESTRO	RIGHT PROFIL	PROFIL DROIT	RECHT PROFIL
66	25599001/0	1	PROFILO SINISTRO	LEFT PROFIL	PROFIL GAUCHE	LINK PROFIL
67	12731580/0	6	VITE	SCREW	VIS	SCHRAUBE
72	12735402/0	4	VITE	SCREW	VIS	SCHRAUBE
81	82110200/1	1	COPERTURA SACCO	GRASS-CATCHER COVER	COUVRE-BAC	SACKKAPPE
82	25547025/1	1	PIASTRINA	PLATE	PLAQUE	PLATTE
83	12674701/0	2	VITE	SCREW	VIS	SCHRAUBE
84	12729601/1	4	VITE	SCREW	VIS	SCHRAUBE
85	12582101/0	2	GROWER	GROWER	GROWER	GROWER
86	12521331/0	6	RONDELLA	WASHER	RONDELLE	SCHEIBE
101	82869019/0	1	PROTEZIONE SILENZIATORE	MUFFLER PROTECTION	PROTECTION SILENCIEUX	AUSPUFFSCHUTZ
102	18737857/0	2	PUNTALE	CAP	BOUCHON	PFROPFEN
103	12734995/0	4	VITE	SCREW	VIS	SCHRAUBE
104	25547109/1	2	PIASTRINA	PLATE	PLAQUE	PLATTE
106	12731580/0	4	VITE	SCREW	VIS	SCHRAUBE
			<b>Nei modelli con innesto delle lame a leva:</b>	<b>For models with engagement of the blades by lever:</b>	<b>Dans les modèles avec em-brayage des lames à levier:</b>	<b>Bei Modellen mit Hebelschaltung der Messer:</b>
16	25120153/1	1	CRUSCOTTO	DASHBOARD	TABLEAU DE BORD	KONSOLE
71	25109702/1	1	COPERTURA RUOTE	WHEELS COVER	COUVRE-ROUES	RADENKAPPE
71	25109700/1	1	COPERTURA RUOTE (hydro)	WHEELS COVER (hydro)	COUVRE-ROUES (hydro)	RADENKAPPE (hydro)
			<b>Nei modelli con innesto delle lame elettromagnetico:</b>	<b>For models with engagement of the blades by electromagnetic clutch:</b>	<b>Dans les modèles avec embrayage des lames électromagnétique:</b>	<b>Bei Modellen mit elektro-magnetischer Schaltung der Messer:</b>
16	25120171/1	1	CRUSCOTTO	DASHBOARD	TABLEAU DE BORD	KONSOLE
71	25109703/1	1	COPERTURA RUOTE	WHEELS COVER	COUVRE-ROUES	RADENKAPPE
71	25109701/1	1	COPERTURA RUOTE (hydro)	WHEELS COVER (hydro)	COUVRE-ROUES (hydro)	RADENKAPPE (hydro)

TC	TCP	TCR	TCB	TCX	TX
102	102 hydro	122 hydro			

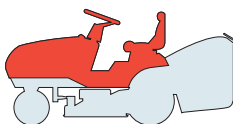

CARROZZERIA  
BODY  
CARROSSERIE  
KARROSSERIE

2006
002e.0
1 / 2

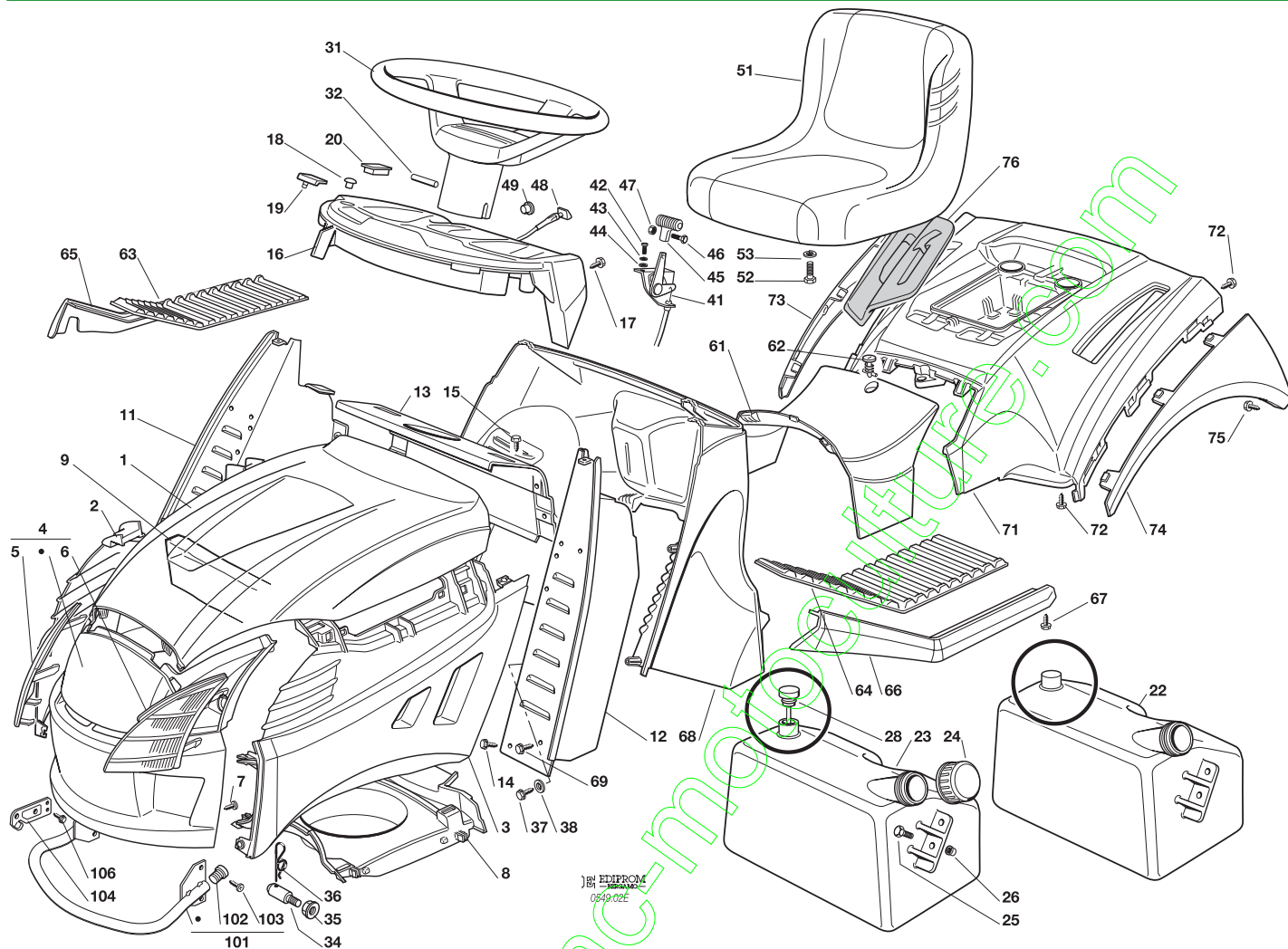

N.	CODE	Q.TY	DESCRIZIONE	DESCRIPTION	DESCRIPTION	BESCHREIBUNG
1	25076858/0	1	COFANO SUPERIORE	UPPER ENGINE HOOD	CAPOT SUPERIEURE	OBERHAUBESATZ
2	25207120/0	1	COFANO DX	HOOD, RIGHT	CAPOT DROITE	RECHTE HAUBE
3	25207121/0	1	COFANO SX	HOOD, LEFT	CAPOT GAUCHE	LINKE HAUBE
4	82394607/0	1	COFANO FRONTALE	HOOD, FRONT	CAPOT AVANT	VORDE HAUBE
5	25410874/0	1	MASCHERINA DESTRA	RIGHT GRILL	PANNEAU DROITE	RECHTE SCHUTZ
6	25410875/0	1	MASCHERINA SINISTRA	LEFT GRILL	PANNEAU GAUCHE	LINKE SCHUTZ
7	12735405/0	6	VITE	SCREW	VIS	SCHRAUBE
8	25108025/0	1	CONVOGLIATORE	CONVEYOR	CONVOYEUR	KONVEYOR
9	25730016/0	1	SEPARATORE ASPIR. (70)	INTAKE SEPARATOR (70)	SEPARATEUR ASPIR. (70)	AUGENABSCHIEDER (70)
11	82785022/7	1	SUPP. CRUSCOTTO DESTRO	RIGHT DASHBOARD SUPP.	SUPPORT TABLEAU DROITE	RECHTER KONSOLEHALTER
12	82785021/6	1	SUPP. CRUSCOTTO SIN.	LEFT DASHBOARD SUPP.	SUPPORT TABLEAU GAUCHE	LINKER KONSOLEHALTER
13	82785137/0	1	SUPP. CRUSCOTTO CENTR.	CENTRAL DASHBOARD SUPP.	SUPPORT TABLEAU CENTR.	ZENTR. KONSOLE HALTER
14	12735110/0	2	VITE	SCREW	VIS	SCHRAUBE
15	12735110/0	4	VITE	SCREW	VIS	SCHRAUBE
16	25120185/0	1	CRUSCOTTO	DASHBOARD	TABLEAU DE BORD	KONSOLE
17	12728440/0	4	VITE	SCREW	VIS	SCHRAUBE
18	25120200/0	2	TAPPO	PLUG	BOUCHON	PROPFEN
19	25260000/0	2	GOMMINO	GROMMET	PROTECTION	SCHUTZ
22	25735110/3	1	SERBATOIO	TANK	RESERVOIR	TANK
23	25735111/3	1	SERBATOIO	TANK	RESERVOIR	TANK
24	25795000/1	1	TAPPO	CAP	BOUCHON	TANKVERSCHLUSS
25	12789197/0	2	VITE	SCREW	VIS	SCHRAUBE
26	12500092/0	2	RIVETTO	RIVET	RIVET	NIET
28	25290001/0	1	INDICATORE LIVELLO	FUEL LEVEL INDICATOR	INDICATEUR NIVEAU	KRAFTSTOFFMESSER
31	25961214/0	1	VOLANTE	STEERING WHEEL	VOLANT	LENKRAD
32	12620299/0	1	SPINA	PIN	GOUPILLE	STIFT
34	25510068/0	2	PERNO	PIN	PIVOT	BOLZEN





N.	CODE	Q.TY	DESCRIZIONE	DESCRIPTION	DESCRIPTION	BESCHREIBUNG
35	12293201/0	2	DADO	NUT	ECROU	MUTTER
36	24487998/0	1	COPPIGLIA	COTTER PIN	GOUPILLE	SPLIT
37	12731350/0	2	VITE	SCREW	VIS	SCHRAUBE
38	12521330/0	2	RONDELLA	WASHER	RONDELLE	SCHEIBE
41	82000200/1	1	ACCELERATORE (12359)	ACCELERATOR (12359)	ACCELERATEUR (12359)	GAS ZUG (12359)
	82000201/2	1	ACCELERATORE (4678)	ACCELERATOR (4678)	ACCELERATEUR (4678)	GAS-ZUG (4678)
	82000204/1	1	ACCELERATORE (0)	ACCELERATOR (0)	ACCELERATEUR (0)	GAS ZUG (0)
42	12788512/0	2	VITE	SCREW	VIS	SCHRAUBE
43	12581200/0	2	GROWER	GROWER	GROWER	GROWER
44	12521310/0	2	RONDELLA	WASHER	RONDELLE	SCHEIBE
45	25394501/0	1	MANOPOLINA	HANDLE	POIGNE	GRIFF
46	12726388/0	1	VITE	SCREW	VIS	SCHRAUBE
47	12290800/0	1	DADO	NUT	ECROU	MUTTER
48	25090001/2	1	COMANDO STARTER (4678)	CHOKE CONTROL (4678)	COMMANDE STARTER (4678)	STARTER BETAETIGUNG (4678)
	25090004/0	1	COMANDO STARTER (0)	CHOKE CONTROL (0)	COMMANDE STARTER (0)	STARTER BETAETIGUNG (0)
49	25120233/0	1	TAPPO (1235669)	CAP (1235669)	BOUCHON (1235669)	VERSCHLUSS (1235669)
51	25722459/0	1	SEDILE	SEAT	SIEGE	SITZ
52	12793101/0	4	VITE	SCREW	VIS	SCHRAUBE
53	12583500/0	4	GROWER	GROWER	GROWER	GROWER
61	25110303/0	1	COPERTURA CENTRALE	COVER	COUVRE	KAPPE
61	25110306/0	1	COPERTURA CENTR. (hydro)	COVER (hydro)	COUVRE (hydro)	KAPPE (hydro)
62	25580020/0	1	PERNO	PIVOT	GOUJON	STIFT
63	25110278/1	1	COPRIPEDANA DESTRA	RIGHT FOOTBOARDCOVER	COUVRE MARCHEPIED DRO.	RECHTE FUSSBRETTDECKEL
64	25110279/0	1	COPRIPEDANA SINISTRA	LEFT FOOTBOARD COVER	COUVRE MARCHEPIED GAU.	LINKE FUSSBRETTDECKEL
65	25599000/0	1	PROFILO DESTRO	RIGHT PROFIL	PROFIL DROIT	RECHT PROFIL
66	25599001/0	1	PROFILO SINISTRO	LEFT PROFIL	PROFIL GAUCHE	LINK PROFIL
67	12731580/0	6	VITE	SCREW	VIS	SCHRAUBE
68	25785228/0	1	SUPPORTO CRUSCOTTO	DASHBOARD SUPPORT	SUPPORT TABLEAU	KONSOLEHALTER
69	12735403/0	7	VITE	SCREW	VIS	SCHRAUBE
71	25109744/0	1	COPERTURA RUOTE	WHEELS COVER	COUVRE-ROUES	RADENKAPPE
72	12735402/0	4	VITE	SCREW	VIS	SCHRAUBE
73	25109747/0	1	COPRIRUOTA SINISTRO	LEFT WHEEL COVER	COUVRE-ROUE GAU.	LINKE RADKAPPE
74	25109748/0	1	COPRIRUOTA DESTRO	RIGHT WHEEL COVER	COUVRE-ROUE DRO.	RECHTE RADKAPPE
75	12728686/0	2	VITE	SCREW	VIS	SCHRAUBE
101	82869019/0	1	PROTEZIONE SILENZIATORE	MUFFLER PROTECTION	PROTECTION SILENCIEUX	AUSPUFFSCHUTZ
102	18737857/0	2	PUNTALE	CAP	BOUCHON	PFPFFEN
103	12734995/0	4	VITE	SCREW	VIS	SCHRAUBE
104	25547109/1	2	PIASTRINA	PLATE	PLAQUE	PLATTE
106	12731580/0	4	VITE	SCREW	VIS	SCHRAUBE
			<b>Nei modelli con innesto delle lame a leva:</b>	<b>For models with engagement of the blades by lever:</b>	<b>Dans les modèles avec embrayage des lames à levier:</b>	<b>Bei Modellen mit Hebelschaltung der Messer:</b>
20	25120234/0	1	TAPPO	CAP	BOUCHON	VERSCHLUSS
76	25207148/0	1	COPERTURA	COVER	COUVRE	KAPPE
76	25207153/0	1	COPERTURA (hydro)	COVER (hydro)	COUVRE (hydro)	KAPPE (hydro)
			<b>Nei modelli con innesto delle lame elettromagnetico:</b>	<b>For models with engagement of the blades by electromagnetic clutch:</b>	<b>Dans les modèles avec embrayage des lames électromagnétique:</b>	<b>Bei Modellen mit elektromagnetischer Schaltung der Messer:</b>
76	25207129/0	1	COPERTURA (hydro)	COVER (hydro)	COUVRE (hydro)	KAPPE (hydro)

TC	TCP	TCR	TCB	TCX	TX
----	-----	-----	-----	-----	----

102

102 hydro

122 hydro

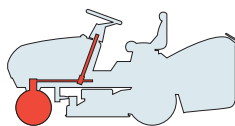

**STERZO**  
**STEERING**  
**BARRE DE DIRECTION**  
**LENKGETRIEBE**

2006

003.0

1 / 2

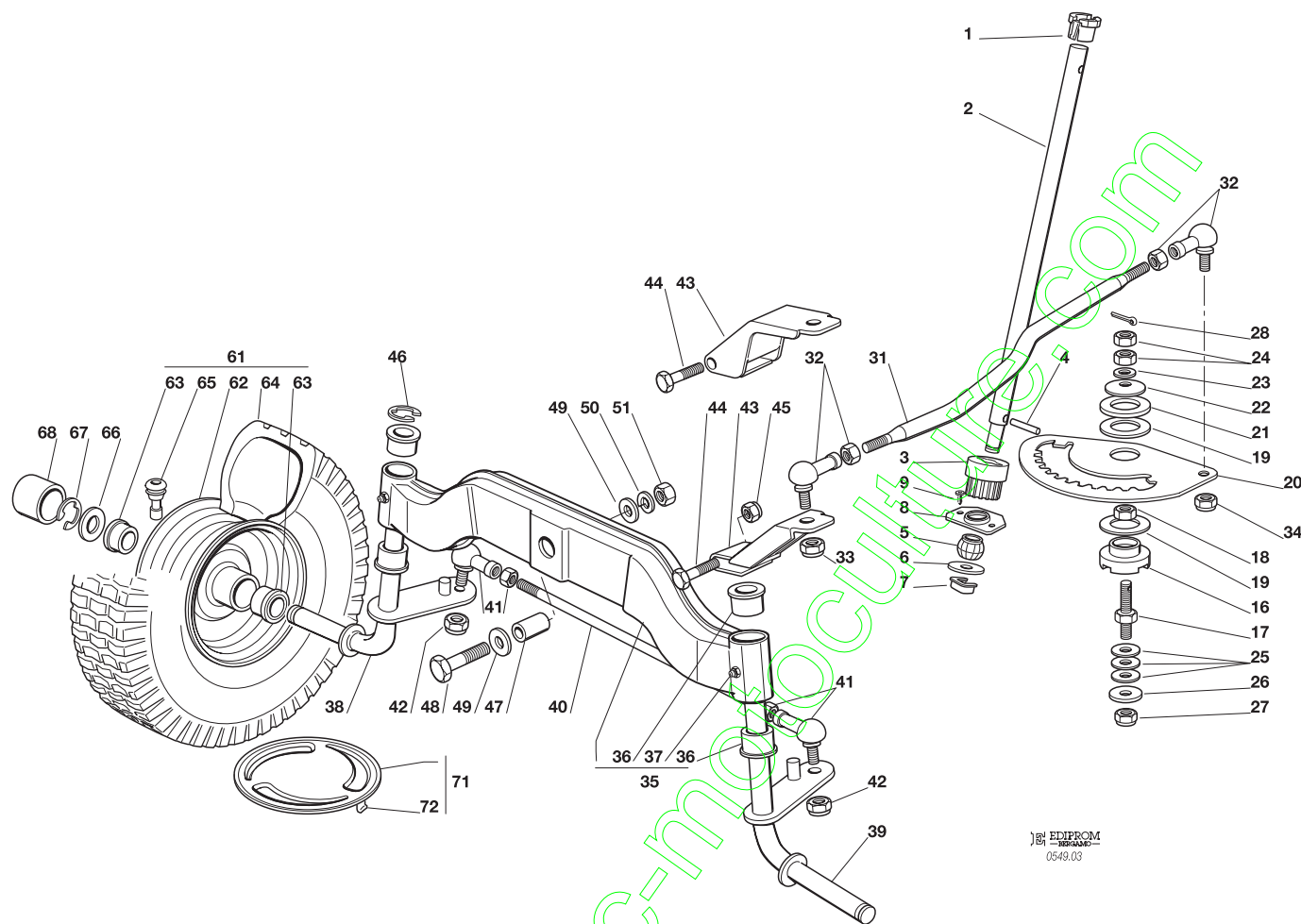

EDIPROM  
0549.03

N.	CODE	Q.TY	DESCRIZIONE	DESCRIPTION	DESCRIPTION	BESCHREIBUNG
1	25038004/0	1	BUSSOLA	BUSH	DOUILLE	BÜCHSE
2	25520005/0	1	PIANTONE	STEERING COLUMN	TUBE DE DIRECTION	LENKUNGSAEULE
3	25570000/2	1	PIGNONE	PINION	PIGNON	RITZEL
4	12622650/0	1	SPINA	PIN	GOUPILLE	STIFT
5	25743000/0	1	SNODO	JOINT	JOINT	GELENK
6	12521370/0	1	RONDELLA	WASHER	RONDELLE	SCHEIBE
7	12436030/0	1	PIASTRINA	PLATE	PLAQUETTE	PLATTECHEN
8	25785213/0	1	SUPPORTO	SUPPORT	SUPPORT	HALTER
9	12729601/1	2	VITE	SCREW	VIS	SCHRAUBE
16	25040617/0	1	BUSSOLA	BUSH	DOUILLE	BÜCHSE
17	25510065/1	1	PERNO	PIN	PIVOT	BOLZEN
18	12295200/0	1	DADO	NUT	ECROU	MUTTER
19	25670012/0	2	RONDELLA	WASHER	RONDELLE	SCHEIBE
20	25735507/0	1	SETTORE	STEERING SHAFT	ARBRE DIRECTION	LENKUNGSWELLE
21	25670014/0	1	RONDELLA	WASHER	RONDELLE	SCHEIBE
22	22160400/0	1	DISCO ELASTICO	ELASTIC WASHER	DISQUE ELASTIQUE	FEDERSCHEIBE
23	12521360/0	1	ROSETTA	WASHER	RONDELLE	SCHEIBE
24	12295200/0	2	DADO	NUT	ECROU	MUTTER
25	22672150/0	3	RONDELLA	WASHER	RONDELLE	SCHEIBE
26	12523080/0	1	RONDELLA	WASHER	RONDELLE	SCHEIBE
27	12156602/0	1	DADO	NUT	ECROU	MUTTER
28	12141418/0	1	COPPIGLIA	COTTER PIN	GOUPILLE	SPLIT
31	25033003/1	1	ASTA COMANDO STERZO	STEERING ROD	BARRE DE DIRECTION	LENKUNGSSTAB
32	22746600/0	2	SNODO	JOINT	JOINT	GELENK
33	12156602/0	1	DADO	NUT	ECROU	MUTTER
34	12156602/0	1	DADO	NUT	ECROU	MUTTER
35	82034001/3	1	BILANCIERE COMPLETO (CON 36 + 37)	EQUALIZER WITH BUSH (WITH 36 + 37)	BALANCIER AVEC (AVEC 36 + 37)	KIPPHEBEL (MIT 36 + 37)







N.	CODE	Q.TY	DESCRIZIONE	DESCRIPTION	DESCRIPTION	BESCHREIBUNG
36	25034002/1	4	BRONZINA	BRASS	COUSSINET	BÜCHSE
37	12379511/0	2	INGRASSATORE	GREASE DISPENSER	GRAISSEUR	FETTBÜCHSE
40	25840001/0	1	TIRANTE	TIE ROD	TIRANT	KUPPLUNG
41	22746600/0	2	SNODO	JOINT	JOINT	GELENK
42	12156602/0	2	DADO	NUT	ECROU	MUTTER
45	12155000/0	1	DADO	NUT	ECROU	MUTTER
46	12001000/0	1	ANELLO ELASTICO	SNAP RING	ANNEAU RESSORT	SPRENGRING
47	25160005/0	1	DISTANZIALE	SPACER	ENTRETOISE	ENTFERNUNGSSTUECK
48	12694100/0	1	VITE	SCREW	VIS	SCHRAUBE
49	12521390/0	2	RONDELLA	WASHER	RONDELLE	SCHEIBE
50	12587900/0	1	GROWER	GROWER	GROWER	GROWER
51	12295800/0	1	DADO	NUT	ECROU	MUTTER
62	82000590/0	2	CERCHIO RUOTA	RIMM	BANDAGE ROUE	VORDERRAD FELGER
63	25122200/2	4	CUSCINETTO	BEARING	ROULEMENT	LAGER
65	25950000/0	2	VALVOLA	VALVE	SOUPAPE	VENTIL
66	25670005/1	2	RONDELLA	WASHER	RONDELLE	SCHEIBE
67	12001000/0	2	ANELLO ELASTICO	SNAP RING	ANNEAU RESSORT	SPRENGRING
68	22110230/0	2	COPRIMOZZO	HUB COVER	COUVRE MOYEU	RADNABE DECKEL
71	82110252/0	2	ASS. COPRIDISCO RUOTA ANTERIORE (TCP - TCB)	FRONT WHEEL COVERENS. ASS.Y (TCP - TCB)	COUVRE DISQUE ROUE ANTER. (TCP - TCB)	VORRERRAD DECKEL (TCP - TCB)
72	25430209/0	8	MOLLA AGGANCIO	SPRING	RESSORT	FEDER

Nei modelli con pneumatici 13": For models with 13" tires:

Dans modèles avec pneus 13":

Bei Modellen mit Reifen 13":

38	82230349/0	1	FUSELLO DESTRO	RIGHT STUB AXLE	FUSEAU DROITE	RECHTER ACHSSCHENKEL
39	82230348/0	1	FUSELLO SINISTRO	LEFT STUB AXLE	FUSEAU GAUCHE	LINKER ACHSSCHENKEL
43	82318101/0	1	LEVA COMANDO	LEVER	LEVIER	HEBEL
44	12691700/0	1	VITE	SCREW	VIS	SCHRAUBE
61	•	2	RUOTA ANTERIORE	FRONT WHEEL	ROUE AVANT	VORDERRAD
	82680002/2		TURF SAVER CARLISLE	TURF SAVER CARLISLE	TURF SAVER CARLISLE	TURF SAVER CARLISLE
	82680005/1		DELI TIRE	DELI TIRE	DELI TIRE	DELI TIRE
64	•	2	PNEUMATICO	TIRE	PNEU	REIFEN
	25590000/0		TURF SAVER CARLISLE	TURF SAVER CARLISLE	TURF SAVER CARLISLE	TURF SAVER CARLISLE
	25590002/0		DELI TIRE	DELI TIRE	DELI TIRE	DELI TIRE

Nei modelli con pneumatici 15": For models with 15" tires:

Dans modèles avec pneus 15":

Bei Modellen mit Reifen 15":

38	82230361/0	1	FUSELLO DESTRO	RIGHT STUB AXLE	FUSEAU DROITE	RECH. ACHSSCHENKEL
39	82230359/0	1	FUSELLO SINISTRO	LEFT STUB AXLE	FUSEAU GAUCHE	LINKER ACHSSCHENKEL
43	82318185/0	1	LEVA COMANDO	LEVER	LEVIER	HEBEL
44	12692395/0	1	VITE	SCREW	VIS	SCHRAUBE
61	•	2	RUOTA ANTERIORE	FRONT WHEEL	ROUE AVANT	VORDERRAD
	82680007/1		TURF SAVER CARLISLE	TURF SAVER CARLISLE	TURF SAVER CARLISLE	TURF SAVER CARLISLE
	82680008/1		DELI TIRE	DELI TIRE	DELI TIRE	DELI TIRE
64	•	2	PNEUMATICO	TIRE	PNEU	REIFEN
	27590051/0		TURF SAVER CARLISLE	TURF SAVER CARLISLE	TURF SAVER CARLISLE	TURF SAVER CARLISLE
	27590053/0		DELI TIRE	DELI TIRE	DELI TIRE	DELI TIRE

contact@ano-motoculture.com

TC	TCP	TCR	TCB	TCX	TX
102	102 hydro	102 hydro	102 hydro	122 hydro	122 hydro

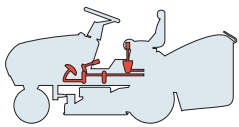

COMANDO FRENO E COMANDO CAMBIO  
 BRAKE AND GEARBOX CONTROLS  
 COMMANDE FREIN ET BOITE DE VITESSE  
 BREMSE UND WECHSEL ANTRIEB

2006
004M.0
1 / 2

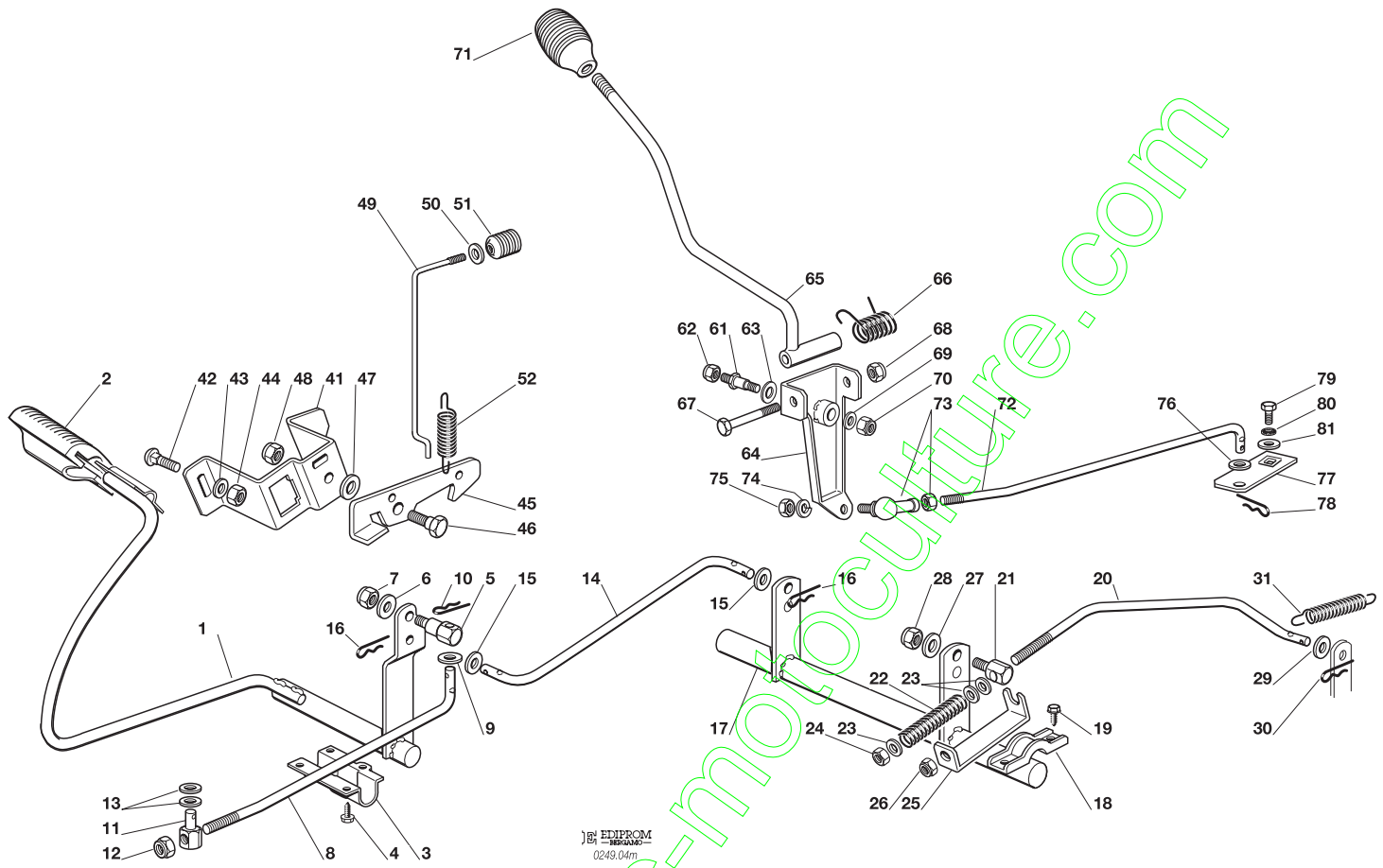

EDIPROM  
 0249.04m

N.	CODE	Q.TY	DESCRIZIONE	DESCRIPTION	DESCRIPTION	BESCHREIBUNG
1	82500015/1	1	PEDALE	PEDAL	PEDAL	PEDAL
2	25110269/0	1	COPRISTAFFA	CLAMP COVER	COUVRE ETRIER	BRIDEDECKEL
3	25547081/1	1	PIASTRINA	PLATE	PLAQUE	PLATTE
4	12731601/0	4	VITE	SCREW	VIS	SCHRAUBE
5	25510063/0	1	PERNO	PIN	PIVOT	BOLZEN
6	12523060/0	1	RONDELLA	WASHER	RONDELLE	SCHEIBE
7	12155000/0	1	DADO	NUT	ECROU	MUTTER
8	25033039/0	1	ASTA	ROD	BARRE	STANGE
9	12521350/0	1	RONDELLA	WASHER	RONDELLE	SCHEIBE
10	24487997/0	1	COPPIGLIA	COTTER PIN	GOUPILLE	SPLIT
11	25510064/0	1	PERNO	PIN	PIVOT	BOLZEN
12	12155000/0	1	DADO	NUT	ECROU	MUTTER
13	25670011/0	2	RONDELLA	WASHER	RONDELLE	SCHEIBE
14	25033038/0	1	ASTA	ROD	BARRE	STANGE
15	12521350/0	2	RONDELLA	WASHER	RONDELLE	SCHEIBE
16	24487997/0	2	COPPIGLIA	COTTER PIN	GOUPILLE	SPLIT
17	82000405/0	1	ASSE RINVIO	AXLE	AXE	ACHSE
18	27546015/1	2	PIASTRINA	PLATE	PLAQUE	PLATTE
19	12731350/0	4	VITE	SCREW	VIS	SCHRAUBE
20	25033040/0	1	ASTA	ROD	BARRE	STANGE
21	25510062/0	1	PERNO	PIN	PIVOT	BOLZEN
22	25430236/0	1	MOLLA	SPRING	RESSORT	FEDER
23	12521360/0	3	RONDELLA	WASHER	RONDELLE	SCHEIBE
24	12295200/0	1	DADO	NUT	ECROU	MUTTER
25	25774275/0	1	STAFFA	CLAMP	ETRIER	BRIDE
26	12156602/0	1	DADO	NUT	ECROU	MUTTER
27	12523060/0	1	RONDELLA	WASHER	RONDELLE	SCHEIBE
28	12155000/0	1	DADO	NUT	ECROU	MUTTER
29	12521360/0	1	RONDELLA	WASHER	RONDELLE	SCHEIBE
30	24487997/0	1	COPPIGLIA	COTTER PIN	GOUPILLE	SPLIT
31	22450500/0	1	MOLLA	SPRING	RESSORT	FEDER





N.	CODE	Q.TY	DESCRIZIONE	DESCRIPTION	DESCRIPTION	BESCHREIBUNG
41	25785143/0	1	SUPPORTO	SUPPORT	SUPPORT	HALTER
42	12815210/0	2	VITE	SCREW	VIS	SCHRAUBE
43	12523040/0	1	RONDELLA	WASHER	RONDELLE	SCHEIBE
44	12154510/0	2	DADO	NUT	ECROU	MUTTER
45	25253001/0	1	GANCIO	HOOK	CROCHET	HAKEN
46	22524970/2	1	PERNO	PIN	PIVOT	BOLZEN
47	25670011/0	1	RONDELLA	WASHER	RONDELLE	SCHEIBE
48	12155000/0	1	DADO	NUT	ECROU	MUTTER
49	25033034/0	1	ASTA	ROD	BARRE	STANGE
	25033047/0	1	ASTA <b>(TX)</b>	ROD <b>(TX)</b>	BARRE <b>(TX)</b>	STANGE <b>(TX)</b>
50	12523020/0	1	RONDELLA	WASHER	RONDELLE	SCHEIBE
51	25394509/1	1	MANOPOLA	KNOB	POIGNEE	KNOPF
52	25430213/0	1	MOLLA	SPRING	RESSORT	FEDER
61	25510035/0	1	PERNO	PIN	PIVOT	BOLZEN
62	12155010/0	1	DADO	NUT	ECROU	MUTTER
63	22672151/0	1	RONDELLA	WASHER	RONDELLE	SCHEIBE
64	82774206/0	1	STAFFA	CLAMP	ETRIER	BRIDE
65	82318179/0	1	LEVA	GEARSHIFT	LEVIER	HEBEL
66	25430226/0	1	MOLLA	SPRING	RESSORT	FEDER
67	12692050/0	1	VITE	SCREW	VIS	SCHRAUBE
68	12155000/0	1	DADO	NUT	ECROU	MUTTER
69	12523060/0	1	RONDELLA	WASHER	RONDELLE	SCHEIBE
70	12155010/0	1	DADO	NUT	ECROU	MUTTER
71	25394510/0	1	MANOPOLA	KNOB	POIGNEE	WECHSEL
72	25033037/0	1	ASTA <b>(Peerless)</b>	ROD <b>(Peerless)</b>	BARRE <b>(Peerless)</b>	STANGE <b>(Peerless)</b>
	25033053/0	1	ASTA <b>(Dana)</b>	ROD <b>(Dana)</b>	BARRE <b>(Dana)</b>	STANGE <b>(Dana)</b>
73	22746601/0	1	SNODO	JOINT	JOINT	GELENK
74	12583500/0	1	GROWER	GROWER	GROWER	GROWER
75	12293200/0	1	DADO	NUT	ECROU	MUTTER
76	12521340/0	1	RONDELLA	WASHER	RONDELLE	SCHEIBE
77	25318169/0	1	LEVA	GEARSHIFT	LEVIER	HEBEL
78	24487997/0	1	COPPIGLIA	COTTER PIN	GOUPILLE	SPLIT
79	12735520/0	1	VITE	SCREW	VIS	SCHRAUBE
80	12540040/0	1	RONDELLA	WASHER	RONDELLE	SCHEIBE
81	22680009/0	1	RONDELLA	WASHER	RONDELLE	SCHEIBE

contact@emc-motoculture.com

TC	TCP	TCR	TCB	TCX	TX
----	-----	-----	-----	-----	----

102

102 hydro

122 hydro

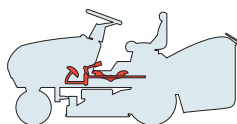

COMANDO TRASMISSIONE E FRENO  
DRIVE AND BRAKE CONTROLS  
COMMANDE TRANSMISSION ET FREIN  
GETRIEBE UND BREMSE ANTRIEB

2006

004Y.0

1 / 2

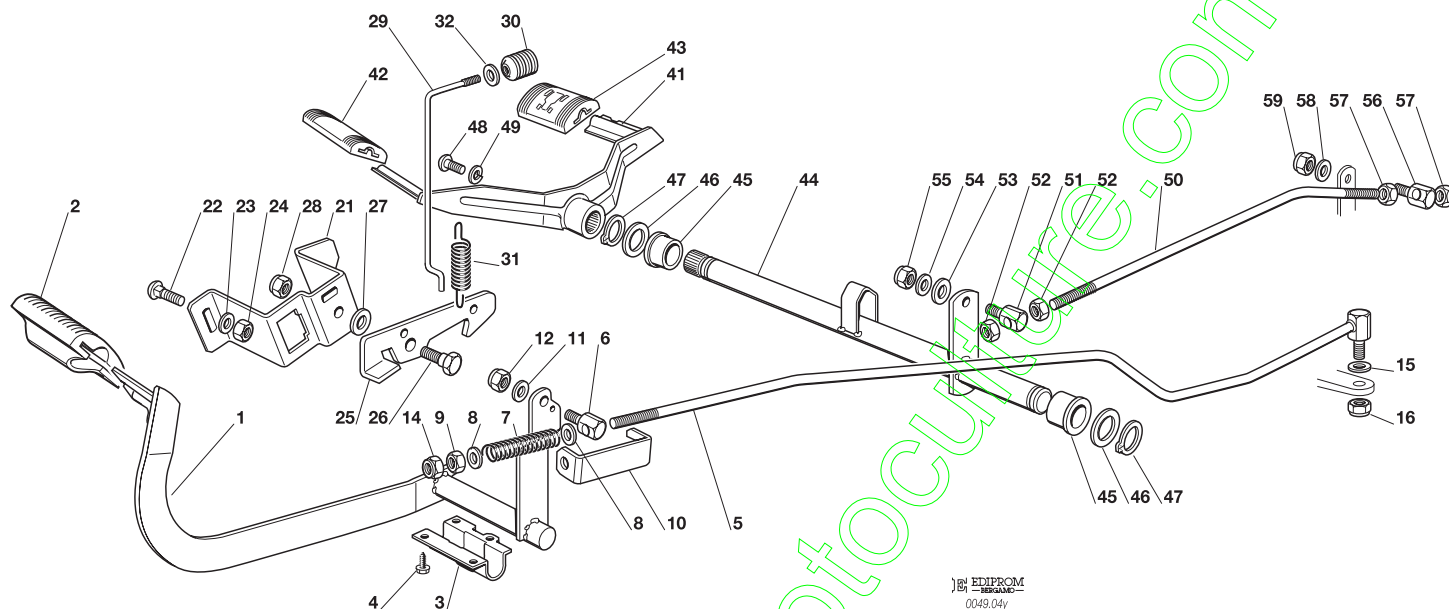

EDIPROM  
0049.04y

N.	CODE	Q.TY	DESCRIZIONE	DESCRIPTION	DESCRIPTION	BESCHREIBUNG
1	82500011/2	1	PEDALE	PEDAL	PEDAL	PEDAL
2	25110267/0	1	COPRISTAFFA	CLAMP COVER	COUVRE ETRIER	BRIDEDECKEL
3	25547081/1	1	PIASTRINA	PLATE	PLAQUE	PLATTE
4	12731601/0	4	VITE	SCREW	VIS	SCHRAUBE
5	82000487/0	1	ASTA	ROD	BARRE	STANGE
6	25510052/0	1	PERNO	PIN	PIVOT	BOLZEN
7	25430236/0	1	MOLLA	SPRING	RESSORT	FEDER
8	12521360/0	2	RONDELLA	WASHER	RONDELLE	SCHEIBE
9	12295200/0	1	DADO	NUT	ECROU	MUTTER
10	25774275/0	1	STAFFA	CLAMP	ETRIER	BRIDE
11	12521350/0	1	RONDELLA	WASHER	RONDELLE	SCHEIBE
12	12155000/0	1	DADO	NUT	ECROU	MUTTER
14	12156602/0	1	DADO	NUT	ECROU	MUTTER
15	12521350/0	1	RONDELLA	WASHER	RONDELLE	SCHEIBE
16	12155000/0	1	DADO	NUT	ECROU	MUTTER
21	25785143/0	1	SUPPORTO	SUPPORT	SUPPORT	HALTER
22	12815210/0	2	VITE	SCREW	VIS	SCHRAUBE
23	12523040/0	1	RONDELLA	WASHER	RONDELLE	SCHEIBE
24	12154510/0	2	DADO	NUT	ECROU	MUTTER
25	25253001/0	1	GANCIO	HOOK	CROCHET	HAKEN
26	22524970/2	1	PERNO	PIN	PIVOT	BOLZEN
27	25670011/0	1	RONDELLA	WASHER	RONDELLE	SCHEIBE
28	12155000/0	1	DADO	NUT	ECROU	MUTTER
29	25033034/0	1	ASTA	ROD	BARRE	STANGE
	25033047/0	1	ASTA (TX)	ROD (TX)	BARRE (TX)	STANGE (TX)
30	25394509/1	1	MANOPOLA	KNOB	POIGNEE	KNOPF
31	25430213/0	1	MOLLA	SPRING	RESSORT	FEDER
32	12523020/0	1	RONDELLA	WASHER	RONDELLE	SCHEIBE
41	82500013/0	1	PEDALE AVANZAMENTO	DRIVE PEDAL	PEDALE TRANSMISSION	GETRIEBEPEDAL







N.	CODE	Q.TY	DESCRIZIONE	DESCRIPTION	DESCRIPTION	BESCHREIBUNG
42	25110265/0	1	COPRISTAFFA ANTERIORE	CLAMP COVER FRONT	COUVRE ETRIER AVANT	BRIDEDECKEL VORDE
43	25110266/0	1	COPRISTAFFA POSTERIORE	CLAMP COVER REAR	COUVRE ETRIER ARRIERE	BRIDEDECKEL HINTER
44	82000481/0	1	ASSE AVANZAMENTO	AXLE	AXE	ACHSE
45	22034523/0	2	BRONZINA	BUSH	DOUILLE	BÜCHSE
46	22672153/0	2	RONDELLA	WASHER	RONDELLE	SCHEIBE
47	12609260/0	2	SEEGER	SEEGER	SEEGER	SEEGER
48	12760600/0	1	VITE	SCREW	VIS	SCHRAUBE
49	12583501/0	1	GROWER	GROWER	GROWER	GROWER
50	25033031/0	1	ASTA	ROD	BARRE	STANGE
51	25510054/0	1	PERNO	PIN	PIVOT	BOLZEN
52	12293200/0	2	DADO	NUT	ECROU	MUTTER
53	12521360/0	1	RONDELLA	WASHER	RONDELLE	SCHEIBE
54	12523040/0	1	RONDELLA	WASHER	RONDELLE	SCHEIBE
55	12154510/0	1	DADO	NUT	ECROU	MUTTER
56	25510054/0	1	PERNO	PIN	PIVOT	BOLZEN
57	12293200/0	2	DADO	NUT	ECROU	MUTTER
58	12523040/0	1	RONDELLA	WASHER	RONDELLE	SCHEIBE
59	12154510/0	1	DADO	NUT	ECROU	MUTTER

contact@emc-motoculture.com

TC	TCP	TCR	TCB	TCX	TX
----	-----	-----	-----	-----	----

102

102 hydro

122 hydro

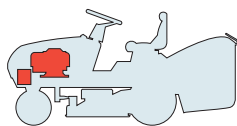

**MOTORE**  
**ENGINE**  
**MOTEUR**  
**MOTOR**  
B&S 12 - 12,5 HP

BRIGGS &amp; STRATTON

2006

005.0

1 / 1

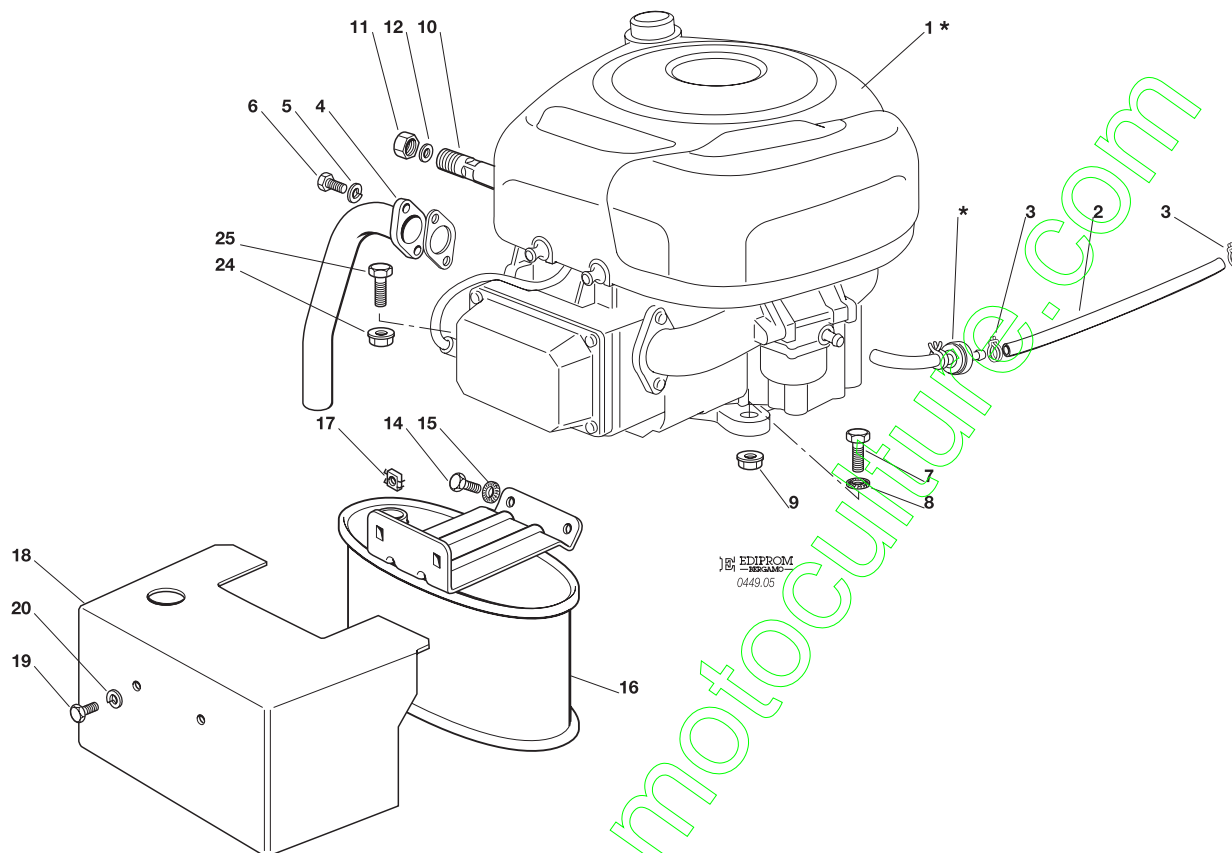

N.	CODE	Q.TY	DESCRIZIONE	DESCRIPTION	DESCRIPTION	BESCHREIBUNG
1*	—	1	MOTORE	ENGINE	MOTEUR	MOTOR
2	25869016/1	1	TUBO COLLEGAMENTO	CONNECTING TUBE	TUBE DE CONNEXION	VERBINDUNGSRÖHR
3	18375051/1	2	FASCETTA	FAIR-LED	FIXATION DE CABLE	KABELBEFESTIGUNG
4	18738224/0	1	TUBO SCARICO	EXHAUST TUBE	TUBE ECHAPPEMENT	ABGASUNGROHR
5	12583500/0	2	GROWER	GROWER	GROWER	GROWER
6	12735530/0	2	VITE	SCREW	VIS	SCHRAUBE
7	12691115/0	1	VITE	SCREW	VIS	SCHRAUBE
8	12540260/0	1	RONDELLA	WASHER	RONDELLE	SCHEIBE
9	12154210/0	1	DADO	NUT	ECROU	MUTTER
10	25598050/0	1	PROLUNGA SCARICO OLIO	OIL DISCHARGE EXTENSION	EXTENSION DECH. HUILE	ÖL ABFLUSS
11	18737849/0	1	TAPPO PROLUNGA	OIL CAP	BOUCHON HUILE	OELVERSCHLUSS
12	18401001/1	1	GUARNIZIONE	OIL SEAL	GARNITURE	DICHTUNG
14	12793102/0	2	VITE	SCREW	VIS	SCHRAUBE
15	12540260/0	2	RONDELLA	WASHER	RONDELLE	SCHEIBE
16	82750004/0	1	SILENZIATORE	MUFFLER	SILENCEUX	AUSPUFF
17	12360425/0	2	DADO	NUT	ECROU	MUTTER
18	82598009/2	1	PROTEZIONE	GUARD	PROTECTION	SCHUTZE
19	12792611/0	2	VITE	SCREW	VIS	SCHRAUBE
20	12583500/0	2	GROWER	GROWER	GROWER	GROWER
24	12154210/0	3	DADO	NUT	ECROU	MUTTER
25	12691100/0	3	VITE	SCREW	VIS	SCHRAUBE

PER LA SOSTITUZIONE DELLE PARTI CONTRASSEGNALE CON «\*» RIVOLGERSI AL SERVIZIO ASSISTENZA DEL COSTRUTTORE DEL MOTORE.  
TO REPLACE THE PARTS MARKED «\*» SEEK ASSISTANCE FROM THE ENGINE MANUFACTURER'S AFTER SALES SERVICE.  
POUR LE REMPLACEMENT DES PIÈCES MARQUÉES AVEC «\*» S'ADRESSER AU SERVICE APRÈS VENTES DU CONSTRUCTEUR DU MOTEUR.  
ZUM AUSTAUSCH DER MIT «\*» GEKENNZEICHNETEN TEILE, WENDEN SIE SICH AN DEN KUNDENDIENST DES HERSTELLERS DES MOTOR.

TC TCP TCR TCB TCX TX

102

102 hydro

122 hydro

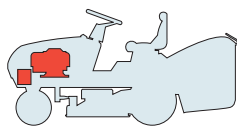

MOTORE  
ENGINE  
MOTEUR  
MOTOR

B&amp;S 15 - 15,5 - 17,5 HP



2006

005a.0

1 / 1

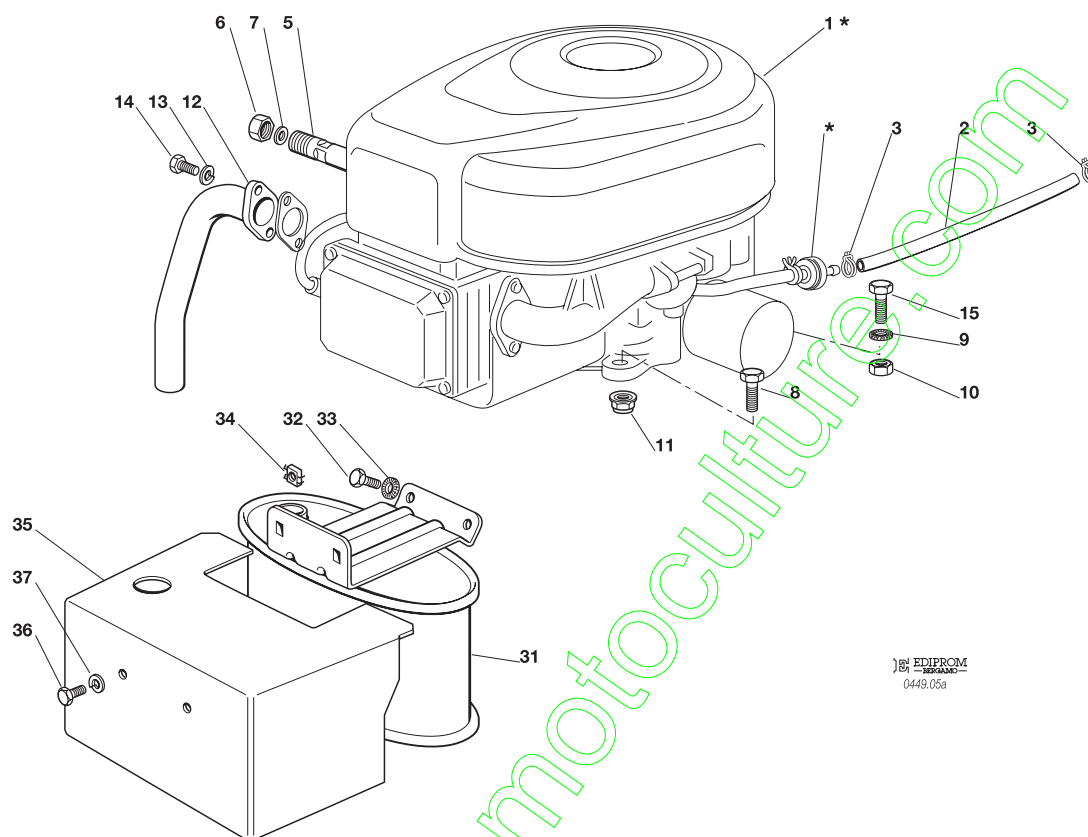

EDIPROM  
0443.05a

N.	CODE	Q.TY	DESCRIZIONE	DESCRIPTION	DESCRIPTION	BESCHREIBUNG
1*	—	1	MOTORE	ENGINE	MOTEUR	MOTOR
2	25869016/1	1	TUBO COLLEGAMENTO	CONNECTING TUBE	TUBE DE CONNEXION	VERBINDUNGSGROHR
3	18375051/1	2	FASCETTA	FAIR LED	FIXATION DE CABLE	KABELBEFESTIGUNG
5	25598050/0	1	PROLUNGA SCARICO OLIO	OIL DISCHARGE EXTENSION	EXTENSION RALLONGE DE DECH. HUILE	ÖL ENTLEERUNGSVERLAEN- GERUNG
6	18737849/0	1	TAPPO PROLUNGA	OIL CAP	BOUCHON HUILE	OELVERSCHLUSS
7	18401001/1	1	GUARNIZIONE	OIL SEAL	GARNITURE	DICHTUNG
8	12691100/0	3	VITE	SCREW	VIS	SCHRAUBE
9	12540260/0	1	RONDELLA	WASHER	RONDELLE	SCHEIBE
10	12154210/0	1	DADO	NUT	ECROU	MUTTER
11	12154210/0	3	DADO	NUT	ECROU	MUTTER
12	18738206/0	1	TUBO RACCORDO SCARICO	EXHAUST CONNECTING TUBE	TUBE DE CONNEXION POUR ECHAPPEMENT	VERBINDUNGSGROHR FÜR ABGASUNG
13	12583500/0	2	GROWER	GROWER	GROWER	GROWER
14	12735530/0	2	VITE	SCREW	VIS	SCHRAUBE
15	12691115/0	1	VITE	SCREW	VIS	SCHRAUBE
31	82750004/0	1	SILENZIATORE	MUFFLER	SILENCEUX	AUSPUFF
32	12793102/0	2	VITE	SCREW	VIS	SCHRAUBE
33	12540260/0	2	RONDELLA	WASHER	RONDELLE	SCHEIBE
34	12360425/0	2	DADO	NUT	ECROU	MUTTER
35	82598009/2	1	PROTEZIONE	GUARD	PROTECTION	SCHUTZE
36	12792611/0	2	VITE	SCREW	VIS	SCHRAUBE
37	12583500/0	2	GROWER	GROWER	GROWER	GROWER

PER LA SOSTITUZIONE DELLE PARTI CONTRASSEGNALE CON «\*» RIVOLGERSI AL SERVIZIO ASSISTENZA DEL COSTRUTTORE DEL MOTORE.  
TO REPLACE THE PARTS MARKED «\*» SEEK ASSISTANCE FROM THE ENGINE MANUFACTURER'S AFTER SALES SERVICE.  
POUR LE REMPLACEMENT DES PIÈCES MARQUÉES AVEC «\*» S'ADRESSER AU SERVICE APRÈS VENTES DU CONSTRUCTEUR DU MOTEUR.  
ZUM AUSTAUSCH DER MIT «\*» GEKENNZEICHNETEN TEILE, WENDEN SIE SICH AN DEN KUNDENDIENST DES HERSTELLERS DES MOTOR.

TC	TCP	TCR	TCB	TCX	TX
102	102 hydro	102 hydro	102 hydro	102 hydro	102 hydro

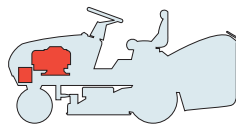

**MOTORE  
ENGINE  
MOTEUR  
MOTOR**  
B&S 18 - 20 - 22 HP



2006  
**005b.0**  
1 / 1

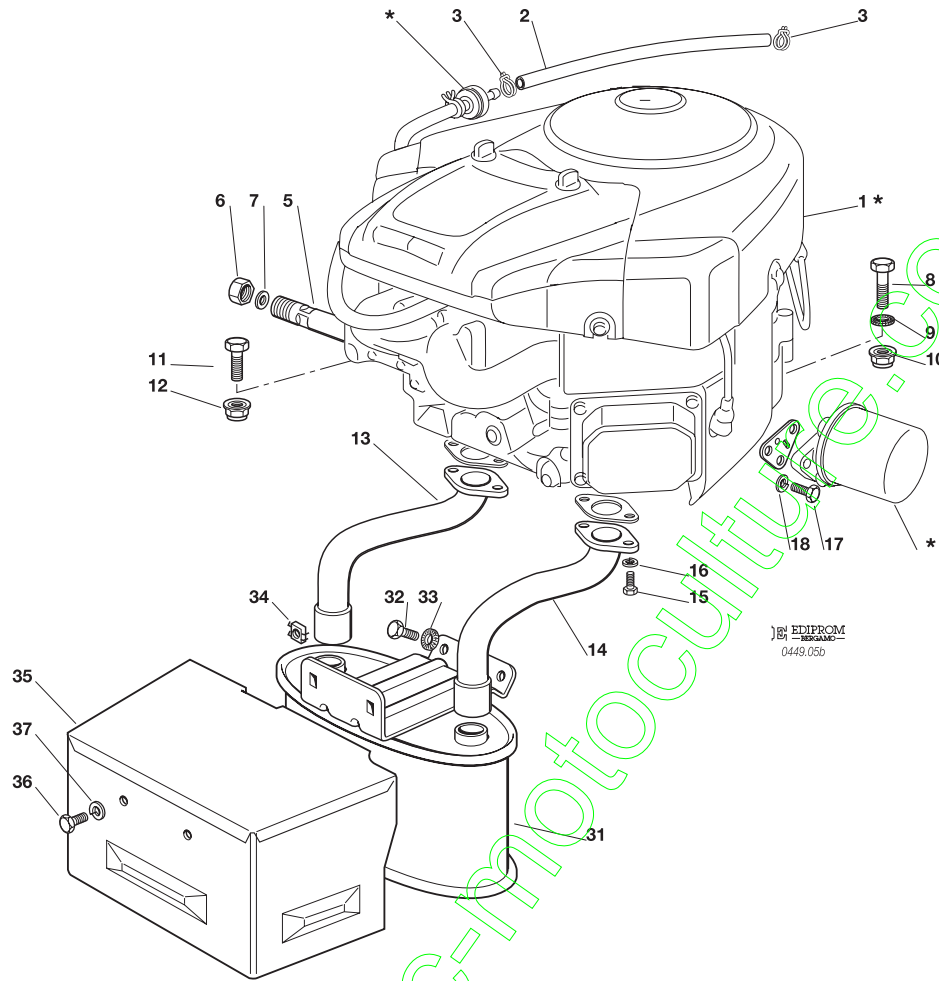

N.	CODE	Q.TY	DESCRIZIONE	DESCRIPTION	DESCRIPTION	BESCHREIBUNG
1*	—	1	MOTORE	ENGINE	MOTEUR	MOTOR
2	25869016/1	1	TUBO COLLEGAMENTO	CONNECTING TUBE	TUBE DE CONNEXION	VERBINDUNGSROHR
3	18375051/1	2	FASCETTA	FAIR-LEAD	FIXATION DE CABLE	KABELBEFESTIGUNG
5	25598050/0	1	PROLUNGA SCARICO OLIO	OIL DISCHARGE EXTENSION	EXTENSION RALLONGE DE DECH. HUILE	ÖL ENTLEERUNGSVERLÄNGERUNG
6	18737849/0	1	TAPPO PROLUNGA	OIL CAP	BOUCHON HUILE	OELVERSCHLUSS
7	18401001/1	1	GUARNIZIONE	OIL SEAL	GARNITURE	DICHTUNG
8	12691115/0	1	VITE	SCREW	VIS	SCHRAUBE
9	12540260/0	1	RONDELLA	WASHER	RONDELLE	SCHEIBE
10	12154210/0	1	DADO	NUT	ECROU	MUTTER
11	12691100/0	3	VITE	SCREW	VIS	SCHRAUBE
12	12154210/0	3	DADO	NUT	ECROU	MUTTER
13	18738214/0	1	TUBO RACCORDO SCARICO DX	EXHAUST RIGHT CONNECTING TUBE	TUBE DE CONNEXION DROIT POUR ECHAPP.	RECHTES VERBINDUNGSROHR FÜR ABGASUNG
14	18738215/0	1	TUBO RACCORDO SCARICO SX	EXHAUST LEFT CONNECTING TUBE	TUBE DE CONNEXION GAUCHE POUR ECHAPP.	LINKES VERBINDUNGSROHR FÜR ABGASUNG
15	12735530/0	4	VITE	SCREW	VIS	SCHRAUBE
16	12583500/0	4	GROWER	GROWER	GROWER	GROWER
17	12791400/0	3	VITE	SCREW	VIS	SCHRAUBE
18	12582100/0	3	GROWER	GROWER	GROWER	GROWER
31	82750003/0	1	SILENZIATORE	MUFFLER	SILENCEUX	AUSPUFF
32	12793102/0	2	VITE	SCREW	VIS	SCHRAUBE
33	12540260/0	2	RONDELLA	WASHER	RONDELLE	SCHEIBE
34	12360425/0	2	DADO	NUT	ECROU	MUTTER
35	82598005/2	1	PROTEZIONE	GUARD	PROTECTION	SCHUTZE
36	12792611/0	2	VITE	SCREW	VIS	SCHRAUBE
37	12583500/0	2	GROWER	GROWER	GROWER	GROWER

PER LA SOSTITUZIONE DELLE PARTI CONTRASSEGNALE CON «\*» RIVOLGERSI AL SERVIZIO ASSISTENZA DEL COSTRUTTORE DEL MOTORE.  
 TO REPLACE THE PARTS MARKED «\*» SEEK ASSISTANCE FROM THE ENGINE MANUFACTURER'S AFTER SALES SERVICE.  
 POUR LE REMPLACEMENT DES PIÈCES MARQUÉES AVEC «\*» S'ADRESSER AU SERVICE APRÈS VENTES DU CONSTRUCTEUR DU MOTEUR.  
 ZUM AUSTAUSCH DER MIT «\*» GEKENNZEICHNETEN TEILE, WENDEN SIE SICH AN DEN KUNDENDIENST DES HERSTELLERS DES MOTOR.



TC TCP TCR TCB TCX TX

102

102 hydro

122 hydro

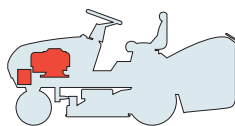

MOTORE  
ENGINE  
MOTEUR  
MOTOR  
TECUMSEH 13,5 HP



2006

005c.0

1 / 1

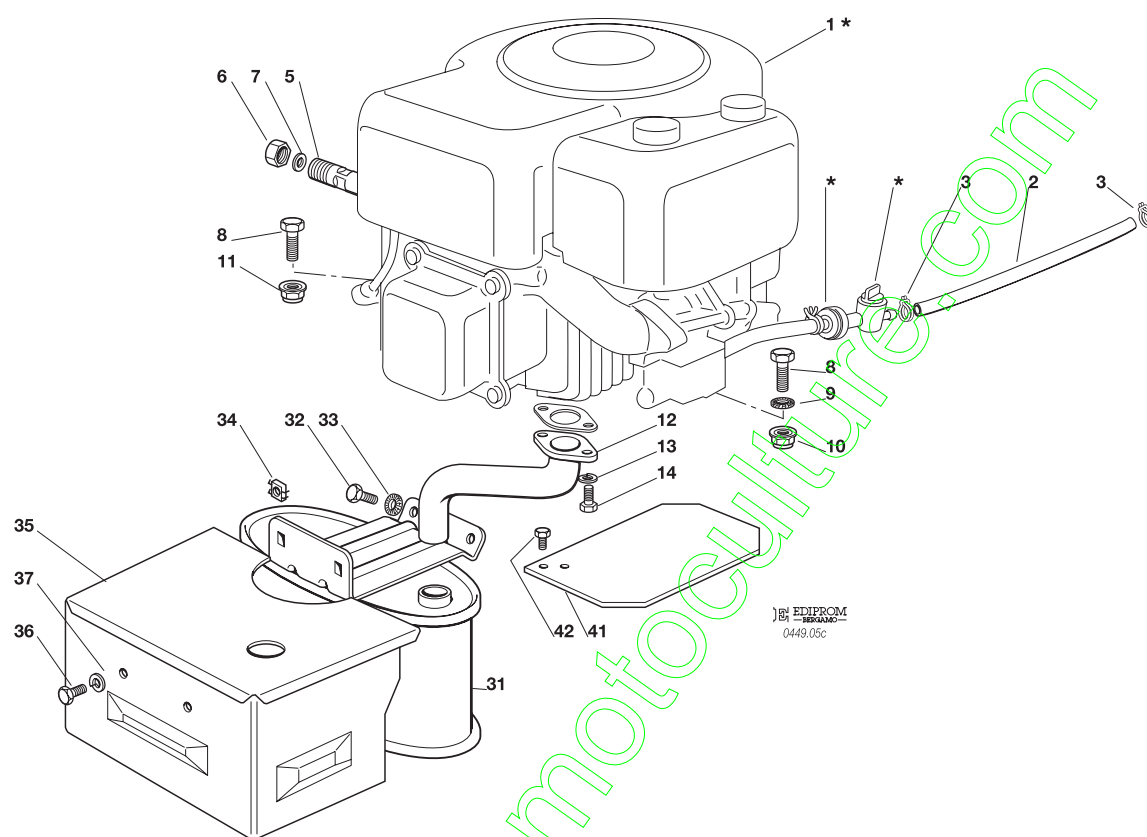

EDIPROM  
0449.05C

N.	CODE	Q.TY	DESCRIZIONE	DESCRIPTION	DESCRIPTION	BESCHREIBUNG
1*	—	1	MOTORE	ENGINE	MOTEUR	MOTOR
2	25869003/1	1	TUBO COLLEGAMENTO	CONNECTING TUBE	TUBE DE CONNEXION	VERBINDUNGSRÖHR
3	18375051/1	2	FASCETTA	FAIR LED	FIXATION DE CABLE	KABELBEFESTIGUNG
5	25598050/0	1	PROLUNGA SCARICO OLIO	OIL DISCHARGE EXTENSION	EXTENSION RALLONGE DE DECH. HUILE	ÖL ENTLEERUNGSVERLÄEN- GERUNG
6	18737849/0	1	TAPPO PROLUNGA	OIL CAP	BOUCHON HUILE	OELVERSCHLUSS
7	18401001/1	1	GUARNIZIONE	OIL SEAL	GARNITURE	DICHTUNG
8	12691100/0	4	VITE	SCREW	VIS	SCHRAUBE
9	12540260/0	1	RONDELLA	WASHER	RONDELLE	SCHEIBE
10	12154210/0	1	DADO	NUT	ECROU	MUTTER
11	12154210/0	3	DADO	NUT	ECROU	MUTTER
12	18738211/0	1	TUBO RACCORDO SCARICO	EXHAUST CONNECTING TUBE	TUBE DE CONNEXION POUR ECHAPPEMENT	VERBINDUNGSRÖHR FÜR ABGASUNG
13	12583500/0	2	GROWER	GROWER	GROWER	GROWER
14	12735530/0	2	VITE	SCREW	VIS	SCHRAUBE
31	82750005/0	1	SILENZIATORE	MUFFLER	SILENCEUX	AUSPUFF
32	12793102/0	2	VITE	SCREW	VIS	SCHRAUBE
33	12540260/0	2	RONDELLA	WASHER	RONDELLE	SCHEIBE
34	12360425/0	2	DADO	NUT	ECROU	MUTTER
35	82598017/0	1	PROTEZIONE	GUARD	PROTECTION	SCHUTZE
36	12792611/0	2	VITE	SCREW	VIS	SCHRAUBE
37	12583500/0	2	GROWER	GROWER	GROWER	GROWER
41	25600031/0	1	PROTEZIONE SILENZIATORE	MUFFLER PROTECTION	PROTECTION SILENCEUX	AUSPUFFSCHUTZ
42	12735106/0	2	VITE	SCREW	VIS	SCHRAUBE

PER LA SOSTITUZIONE DELLE PARTI CONTRASSEGNALE CON «\*» RIVOLGERSI AL SERVIZIO ASSISTENZA DEL COSTRUTTORE DEL MOTORE.  
TO REPLACE THE PARTS MARKED «\*» SEEK ASSISTANCE FROM THE ENGINE MANUFACTURER'S AFTER SALES SERVICE.  
POUR LE REMPLACEMENT DES PIÈCES MARQUÉES AVEC «\*» S'ADRESSER AU SERVICE APRÈS VENTES DU CONSTRUCTEUR DU MOTEUR.  
ZUM AUSTAUSCH DER MIT «\*» GEKENNZEICHNETEN TEILE, WENDEN SIE SICH AN DEN KUNDENDIENST DES HERSTELLERS DES MOTOR.

TC	TCP	TCR	TCB	TCX	TX
----	-----	-----	-----	-----	----

102

102 hydro

122 hydro

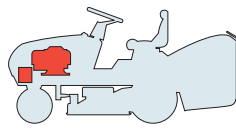

MOTORE  
ENGINE  
MOTEUR  
MOTOR

TECUMSEH 14,5 - 15 - 16 HP



2006

005d.0

1 / 1

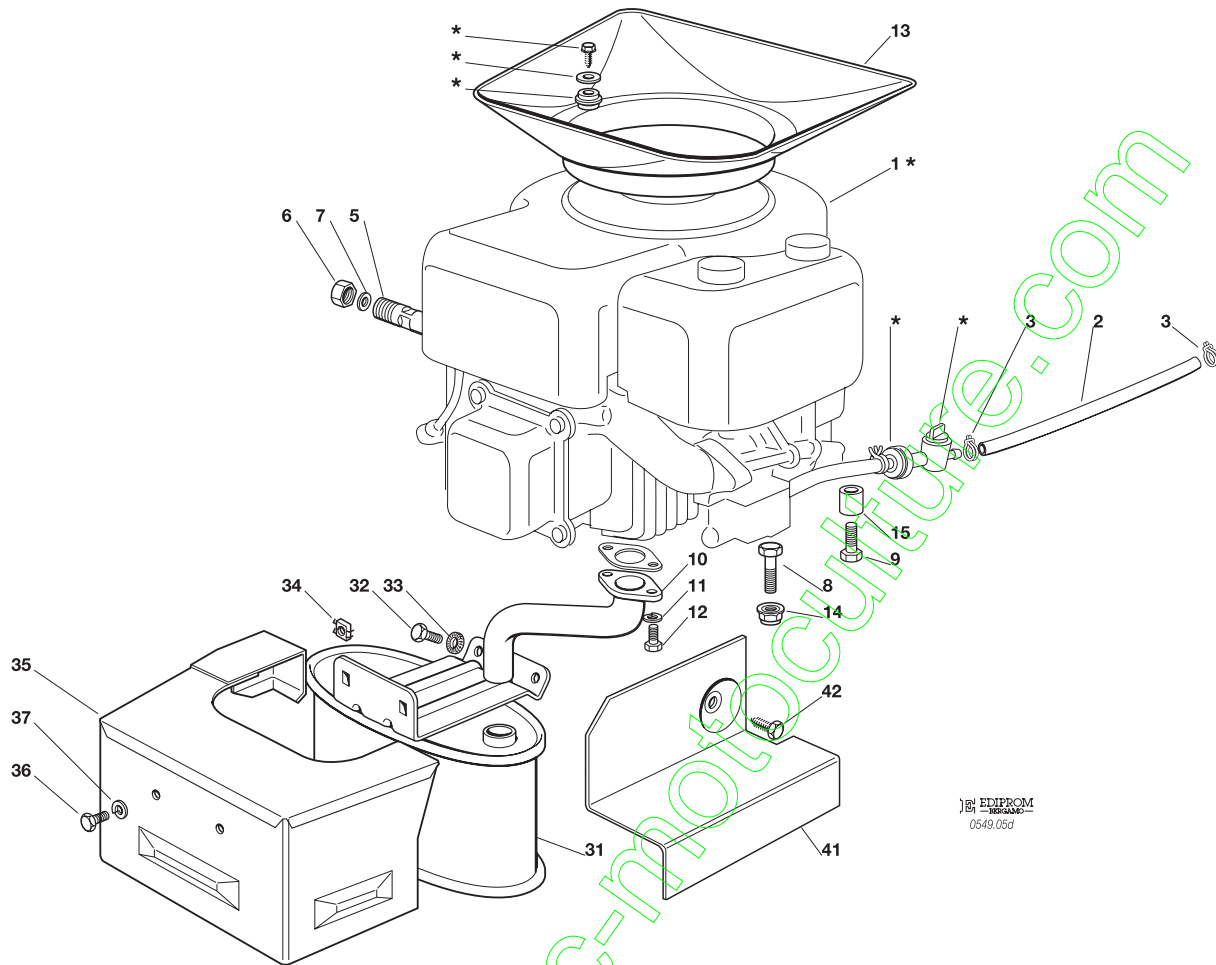

EDIPROM  
0549.06d

N.	CODE	Q.TY	DESCRIZIONE	DESCRIPTION	DESCRIPTION	BESCHREIBUNG
1*	—	1	MOTORE	ENGINE	MOTEUR	MOTOR
2	25869012/1	1	TUBO COLLEGAMENTO	CONNECTING TUBE	TUBE DE CONNEXION	VERBINDUNGSROHR
3	18375051/1	2	FASCETTA	FAIR LED	FIXATION DE CABLE	KABELBEFESTIGUNG
5	25598050/0	1	PROLUNGA SCARICO OLIO	OIL DISCHARGE EXTENSION	EXTENSION RALLONGE DE DECH. HUILE	ÖL ENTLEERUNGSVERLAEN- GERUNG
6	18737849/0	1	TAPPO PROLUNGA	OIL CAP	BOUCHON HUILE	OELVERSCHLUSS
7	18401001/1	1	GUARNIZIONE	OIL SEAL	GARNITURE	DICHTUNG
8	12691100/0	1	VITE	SCREW	VIS	SCHRAUBE
9	12735108/0	3	VITE	SCREW	VIS	SCHRAUBE
10	18738230/0	1	TUBO RACCORDO SCARICO	EXHAUST CONNECTING TUBE	TUBE DE CONNEXION POUR ECHAPPEMENT	VERBINDUNGSROHR FÜR ABGASUNG
11	12583500/0	2	GROWER	GROWER	GROWER	GROWER
12	12735530/0	2	VITE	SCREW	VIS	SCHRAUBE
13	25108016/0	1	CONVOGLIATORE	CONVEYOR	CONVOYEUR	KÜHLERHAUBE
14	12154210/0	1	DADO	NUT	ECROU	MUTTER
15	25160035/0	3	DISTANZIALE	SPACER	ENTRETOISE	ENTFERNUNGSSTÜCK
31	82750008/0	1	SILENZIATORE	MUFFLER	SILENCEUX	AUSPUFF
32	12793102/0	2	VITE	SCREW	VIS	SCHRAUBE
33	12540260/0	2	RONDELLA	WASHER	RONDELLE	SCHEIBE
34	12360425/0	2	DADO	NUT	ECROU	MUTTER
35	82598031/0	1	PROTEZIONE	GUARD	PROTECTION	SCHUTZE
36	12792611/0	2	VITE	SCREW	VIS	SCHRAUBE
37	12583500/0	2	GROWER	GROWER	GROWER	GROWER
41	25600038/0	1	PROTEZIONE SILENZIATORE	MUFFLER PROTECTION	PROTECTION SILENCEUX	AUSPUFFSCHUTZ
42	12734995/0	1	VITE	SCREW	VIS	SCHRAUBE

PER LA SOSTITUZIONE DELLE PARTI CONTRASSEGNALE CON «\*» RIVOLGERSI AL SERVIZIO ASSISTENZA DEL COSTRUTTORE DEL MOTORE.  
TO REPLACE THE PARTS MARKED «\*» SEEK ASSISTANCE FROM THE ENGINE MANUFACTURER'S AFTER SALES SERVICE.  
POUR LE REMPLACEMENT DES PIÈCES MARQUÉES AVEC «\*» S'ADRESSER AU SERVICE APRÈS VENTES DU CONSTRUCTEUR DU MOTEUR.  
ZUM AUSTAUSCH DER MIT «\*» GEKENNZEICHNETEN TEILE, WENDEN SIE SICH AN DEN KUNDENDIENST DES HERSTELLERS DES MOTOR.

TC TCP TCR TCB TCX TX

102

102 hydro

122 hydro

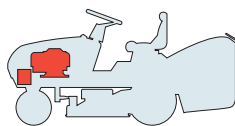

MOTORE  
ENGINE  
MOTEUR  
MOTOR  
TECUMSEH 22 HP



2006

005e.0

1 / 1

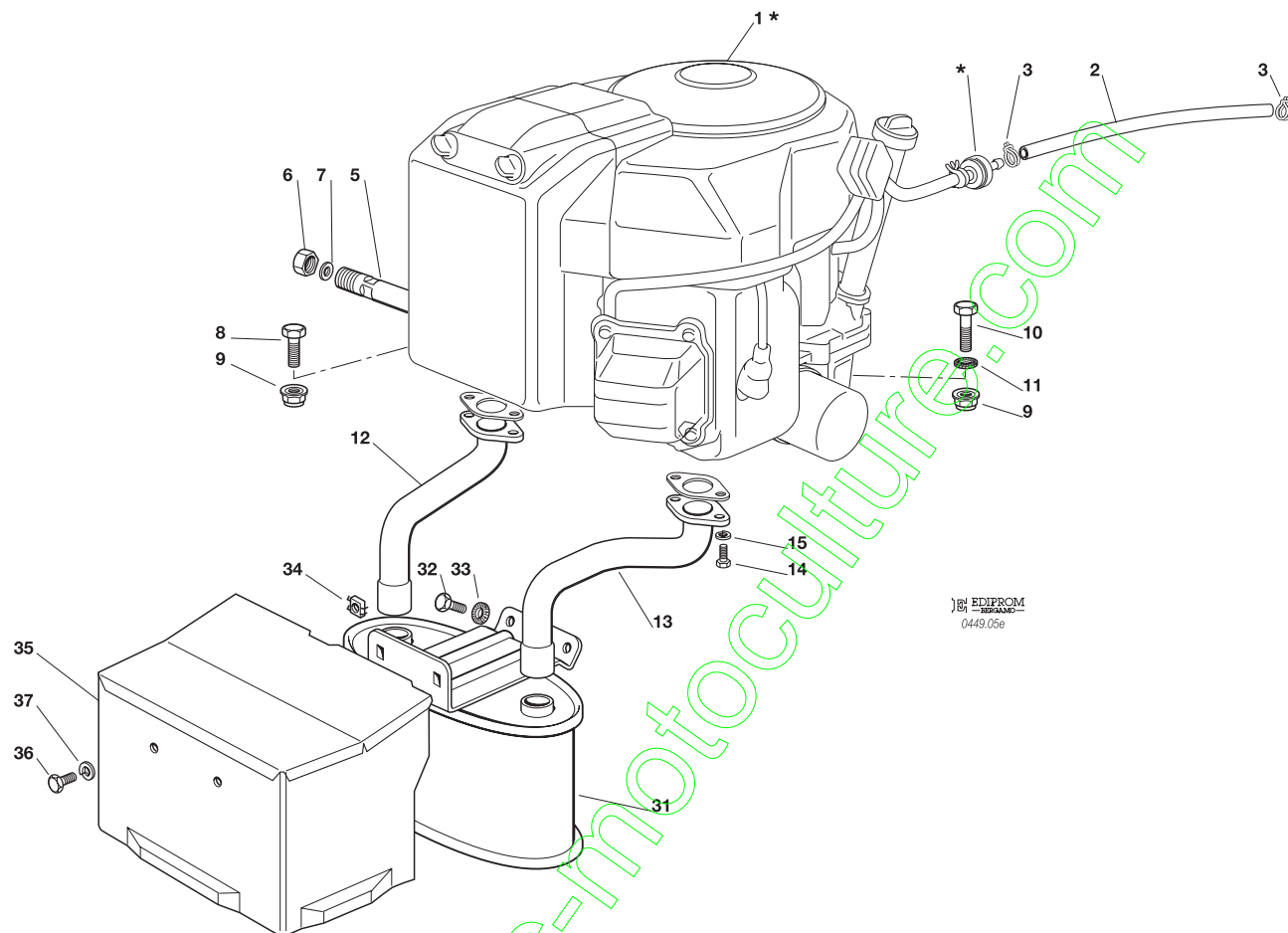

EDIPROM  
0449.05e

N.	CODE	Q.TY	DESCRIZIONE	DESCRIPTION	DESCRIPTION	BESCHREIBUNG
1*	—	1	MOTORE	ENGINE	MOTEUR	MOTOR
2	25869018/1	1	TUBO COLLEGAMENTO	CONNECTING TUBE	TUBE DE CONNEXION	VERBINDUNGSGROHR
3	18375051/1	2	FASCETTA	FAIR LED	FIXATION DE CABLE	KABELBEFESTIGUNG
5	25598050/0	1	PROLUNGA SCARICO OLIO	OIL DISCHARGE EXTENSION	EXTENSION RALLONGE DE DECH. HUILE	ÖL ENTLEERUNGSVERLAENGERUNG
6	18737849/0	1	TAPPO PROLUNGA	OIL CAP	BOUCHON HUILE	OELVERSCHLUSS
7	18401001/1	1	GUARNIZIONE	OIL SEAL	GARNITURE	DICHTUNG
8	12691100/0	3	VITE	SCREW	VIS	SCHRAUBE
9	12154210/0	4	DADO	NUT	ECROU	MUTTER
10	12691115/0	1	VITE	SCREW	VIS	SCHRAUBE
11	12540260/0	1	RONDELLA	WASHER	RONDELLE	SCHEIBE
12	18738229/0	1	TUBO SCARICO DESTRO	EXHAUST TUBE RIGHT	TUBE ECHAPPEMENT DROIT	ABGASUNGROHR, RECHTE
13	18738228/0	1	TUBO SCARICO SINISTRO	EXHAUST TUBE LEFT	TUBE ECHAPPEMENT GAU.	ABGASUNGROHR, LINKE
14	12737450/0	4	VITE	SCREW	VIS	SCHRAUBE
15	12583500/0	4	GROWER	GROWER	GROWER	GROWER
31	82750003/0	1	SILENZIATORE	MUFFLER	SILENCEUX	AUSPUFF
32	12793102/0	2	VITE	SCREW	VIS	SCHRAUBE
33	12540260/0	2	RONDELLA	WASHER	RONDELLE	SCHEIBE
34	12360425/0	2	DADO	NUT	ECROU	MUTTER
35	82598015/1	1	PROTEZIONE	GUARD	PROTECTION	SCHUTZE
36	12792611/0	2	VITE	SCREW	VIS	SCHRAUBE
37	12583500/0	2	GROWER	GROWER	GROWER	GROWER

PER LA SOSTITUZIONE DELLE PARTI CONTRASSEGNALE CON «\*» RIVOLGERSI AL SERVIZIO ASSISTENZA DEL COSTRUTTORE DEL MOTORE.  
TO REPLACE THE PARTS MARKED «\*» SEEK ASSISTANCE FROM THE ENGINE MANUFACTURER'S AFTER SALES SERVICE.  
POUR LE REMPLACEMENT DES PIÈCES MARQUÉES AVEC «\*» S'ADRESSER AU SERVICE APRÈS VENTES DU CONSTRUCTEUR DU MOTEUR.  
ZUM AUSTAUSCH DER MIT «\*» GEKENNZEICHNETEN TEILE, WENDEN SIE SICH AN DEN KUNDENDIENST DES HERSTELLERS DES MOTOR.

TC	TCP	TCR	TCB	TCX	TX
----	-----	-----	-----	-----	----

102

102 hydro

122 hydro

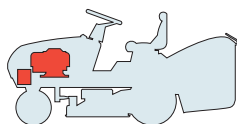

MOTORE  
ENGINE  
MOTEUR  
MOTOR  
HONDA GCV 530

POWERED by  
**HONDA**

2006

005f.0

1 / 1

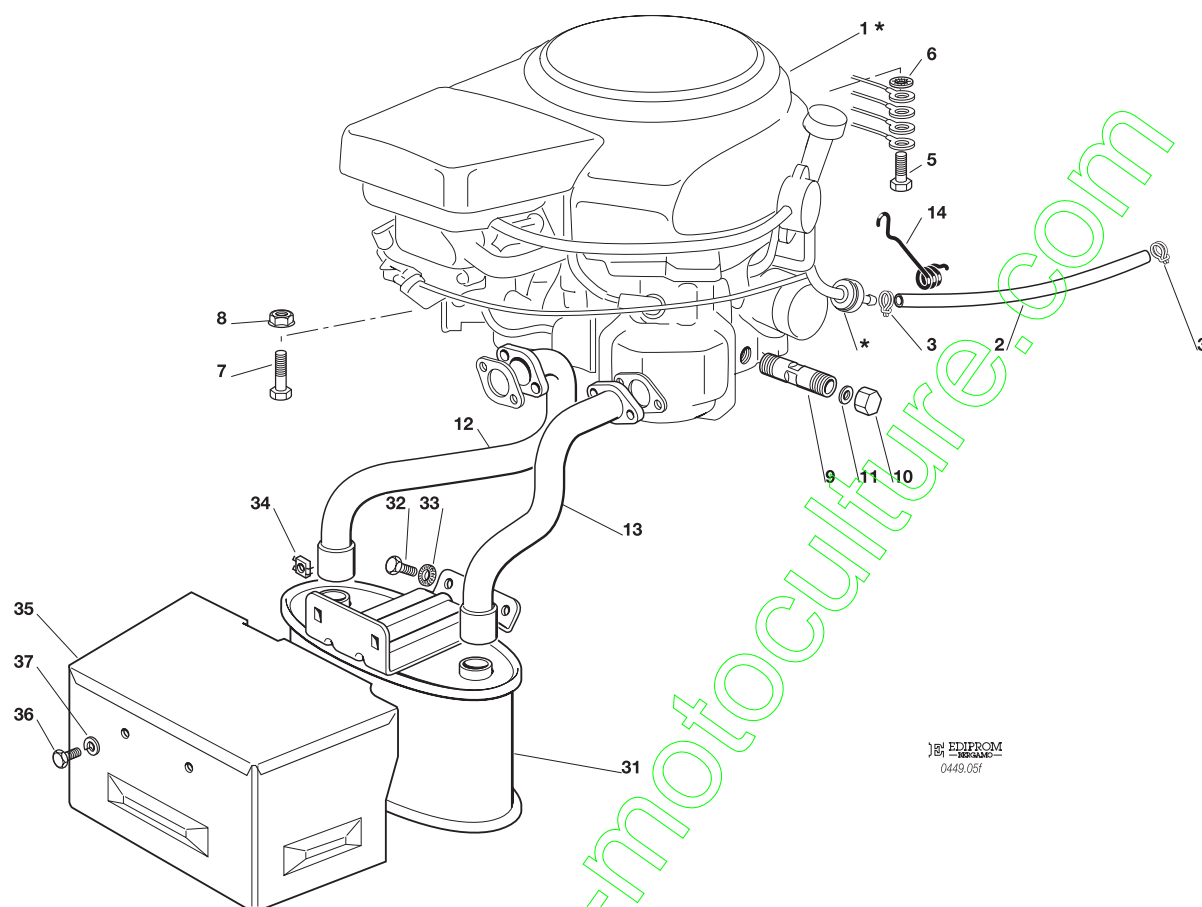

EDIPROM  
0449.05f

N.	CODE	Q.TY	DESCRIZIONE	DESCRIPTION	DESCRIPTION	BESCHREIBUNG
1*	—	1	MOTORE	ENGINE	MOTEUR	MOTOR
2	25869027/1	1	TUBO COLLEGAMENTO	CONNECTING TUBE	TUBE DE CONNEXION	VERBINDUNGSROHR
3	18375051/1	2	FASCETTA	FAIR-LEAD	FIXATION DE CABLE	KABELBEFESTIGUNG
5	12735599/0	1	VITE	SCREW	VIS	SCHRAUBE
6	12540260/0	1	RONDELLA	WASHER	RONDELLE	SCHEIBE
7	12691115/0	4	VITE	SCREW	VIS	SCHRAUBE
8	12154210/0	4	DADO	NUT	ECROU	MUTTER
9	25598052/0	1	PROLUNGA SCARICO OLIO	OIL DISCHARGE EXTENSION	EXTENSION DECH. HUILE	ÖL ABFLUSS
10	18737849/0	1	TAPPO PROLUNGA	OIL CAP	BOUCHON HUILE	OELVERSCHLUSS
11	18401001/1	1	GUARNIZIONE	OIL SEAL	GARNITURE	DICHTUNG
12	18738221/0	1	TUBO SCARICO DESTRO	EXHAUST TUBE RIGHT	TUBE ECHAPPEMENT DROIT	ABGASUNGROHR, RECHTE
13	18738222/0	1	TUBO SCARICO SINISTRO	EXHAUST TUBE LEFT	TUBE ECHAPPEMENT GAU.	ABGASUNGROHR, LINKE
14	27430562/0	1	MOLLA	SPRING	RESSORT	FEDER
31	82750003/0	1	SILENZIATORE	MUFFLER	SILENCEUX	AUSPUFF
32	12793102/0	2	VITE	SCREW	VIS	SCHRAUBE
33	12540260/0	2	RONDELLA	WASHER	RONDELLE	SCHEIBE
34	12360425/0	2	DADO	NUT	ECROU	MUTTER
35	82598005/2	1	PROTEZIONE	GUARD	PROTECTION	SCHUTZE
36	12792611/0	2	VITE	SCREW	VIS	SCHRAUBE
37	12583500/0	2	GROWER	GROWER	GROWER	GROWER

PER LA SOSTITUZIONE DELLE PARTI CONTRASSEGNALE CON «\*» RIVOLGERSI AL SERVIZIO ASSISTENZA DEL COSTRUTTORE DEL MOTORE.  
TO REPLACE THE PARTS MARKED «\*» SEEK ASSISTANCE FROM THE ENGINE MANUFACTURER'S AFTER SALES SERVICE.  
POUR LE REMPLACEMENT DES PIÈCES MARQUÉES AVEC «\*» S'ADRESSER AU SERVICE APRÈS VENTES DU CONSTRUCTEUR DU MOTEUR.  
ZUM AUSTAUSCH DER MIT «\*» GEKENNZEICHNETEN TEILE, WENDEN SIE SICH AN DEN KUNDENDIENST DES HERSTELLERS DES MOTOR.



TC

TCP

TCR

TCB

TCX

TX

102

102 hydro

122 hydro

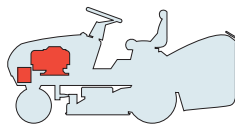

MOTORE  
ENGINE  
MOTEUR  
MOTOR  
HONDA GXV 610

POWERED by  
**HONDA**

2006

005g.0

1 / 1

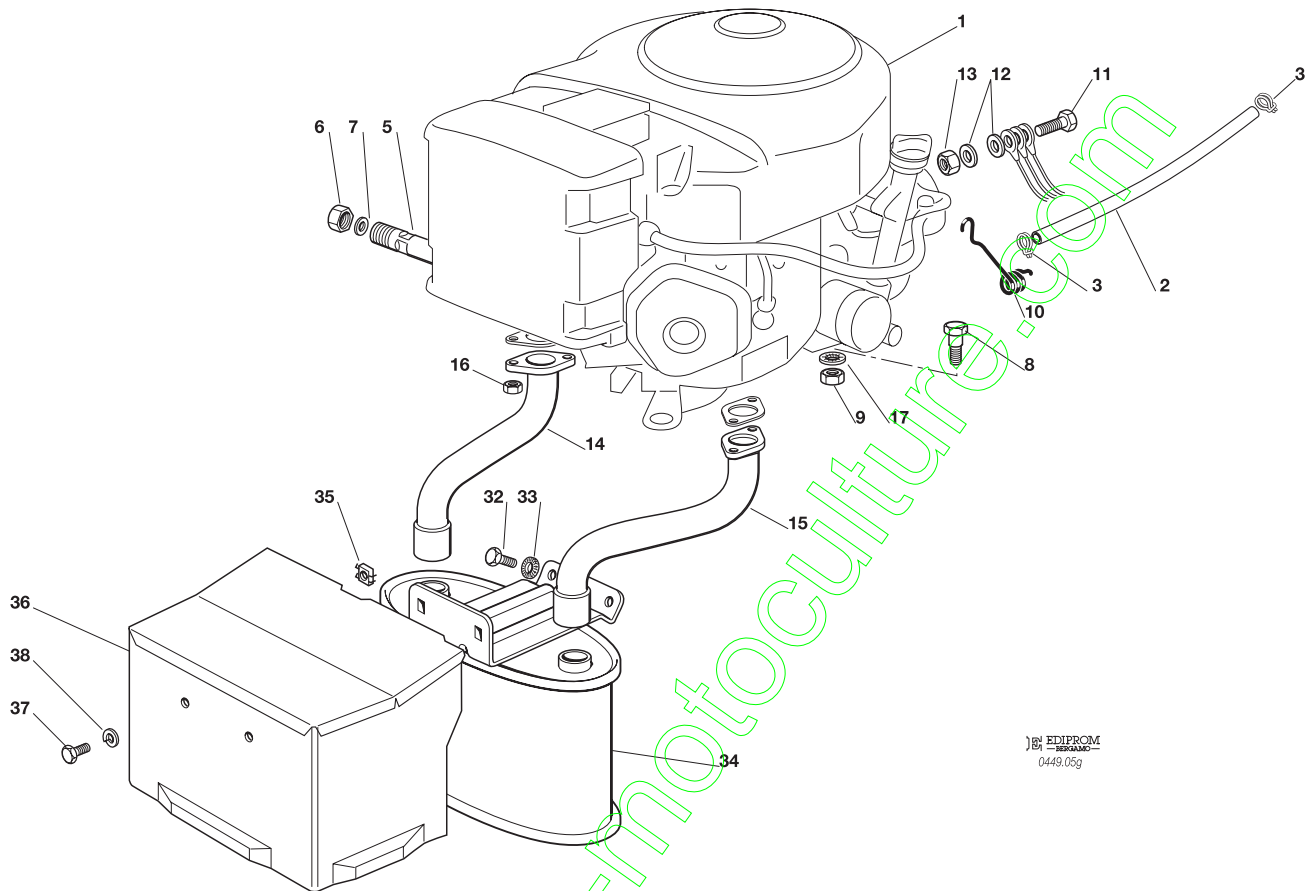

EDIPROM  
0449.05g

N.	CODE	Q.TY	DESCRIZIONE	DESCRIPTION	DESCRIPTION	BESCHREIBUNG
1*	—	1	MOTORE	ENGINE	MOTEUR	MOTOR
2	25869033/1	1	TUBO COLLEGAMENTO	CONNECTING TUBE	TUBE DE CONNEXION	VERBINDUNGSGROHR
3	18375051/1	2	FASCETTA	FAIR LED	FIXATION DE CABLE	KABELBEFESTIGUNG
5	27598061/1	1	PROLUNGA SCARICO OLIO	OIL DISCHARGE EXTENSION	EXTENSION RALLONGE DE DECH. HUILE	ÖL ENTLEERUNGSVERLAEN- GERUNG
6	18737849/0	1	TAPPO PROLUNGA	OIL CAP	BOUCHON HUILE	OELVERSCHLUSS
7	18401001/1	1	GUARNIZIONE	OIL SEAL	GARNITURE	DICHTUNG
8	25510028/1	4	VITE	SCREW	VIS	SCHRAUBE
9	12154210/0	4	DADO	NUT	ECROU	MUTTER
10	27430561/0	1	MOLLA	SPRING	RESSORT	FEDER
11	12691115/0	1	VITE	SCREW	VIS	SCHRAUBE
12	12521350/0	2	RONDELLA	WASHER	RONDELLE	SCHEIBE
13	12293201/0	1	DADO	NUT	ECROU	MUTTER
14	18738219/0	1	TUBO SCARICO DESTRO	EXHAUST TUBE RIGHT	TUBE ECHAPPEMENT DROIT	ABGASUNGSGROHR, RECHTE
15	18738220/0	1	TUBO SCARICO SINISTRO	EXHAUST TUBE LEFT	TUBE ECHAPPEMENT GAU.	ABGASUNGSGROHR, LINKE
16	12293201/0	4	DADO	NUT	ECROU	MUTTER
17	12540260/0	1	RONDELLA	WASHER	RONDELLE	SCHEIBE
32	12793102/0	2	VITE	SCREW	VIS	SCHRAUBE
33	12540260/0	2	RONDELLA	WASHER	RONDELLE	SCHEIBE
34	82750003/0	1	SILENZIATORE	MUFFLER	SILENCEUX	AUSPUFF
35	12360425/0	2	DADO	NUT	ECROU	MUTTER
36	82598015/1	1	PROTEZIONE	GUARD	PROTECTION	SCHUTZE
37	12792611/0	2	VITE	SCREW	VIS	SCHRAUBE
38	12583500/0	2	GROWER	GROWER	GROWER	GROWER

PER LA SOSTITUZIONE DELLE PARTI CONTRASSEGNALE CON «\*» RIVOLGERSI AL SERVIZIO ASSISTENZA DEL COSTRUTTORE DEL MOTORE.  
TO REPLACE THE PARTS MARKED «\*» SEEK ASSISTANCE FROM THE ENGINE MANUFACTURER'S AFTER SALES SERVICE.  
POUR LE REMPLACEMENT DES PIÈCES MARQUÉES AVEC «\*» S'ADRESSER AU SERVICE APRÈS VENTES DU CONSTRUCTEUR DU MOTEUR.  
ZUM AUSTAUSCH DER MIT «\*» GEKENNZEICHNETEN TEILE, WENDEN SIE SICH AN DEN KUNDENDIENST DES HERSTELLERS DES MOTOR.

TC	TCP	TCR	TCB	TCX	TX
102	102 hydro	102 hydro	102 hydro	122 hydro	122 hydro

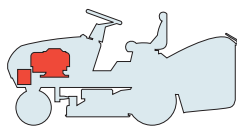

MOTORE  
ENGINE  
MOTEUR  
MOTOR  
KOHLER 16 - 18 HP

**KOHLER**

2006  
005h.0  
1 / 1

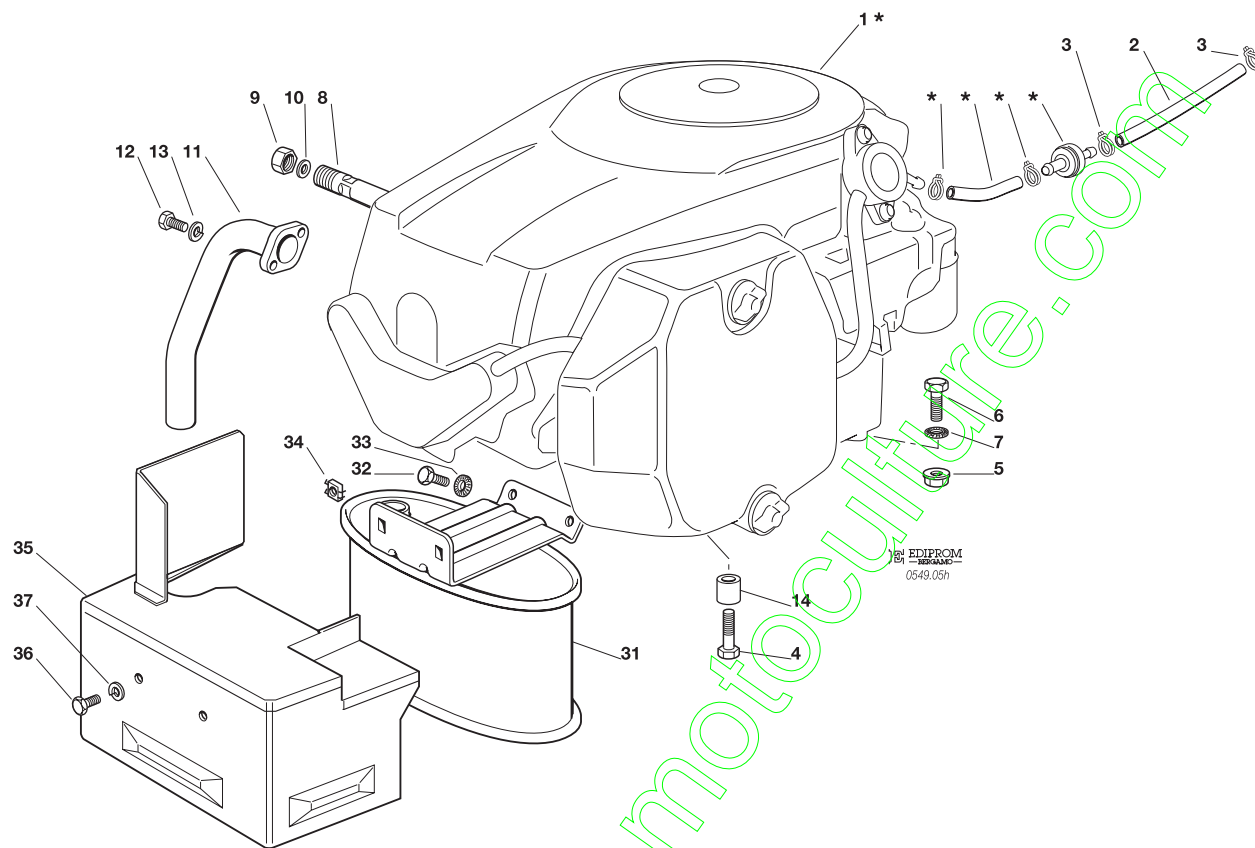

N.	CODE	Q.TY	DESCRIZIONE	DESCRIPTION	DESCRIPTION	BESCHREIBUNG
1*	—	1	MOTORE	ENGINE	MOTEUR	MOTOR
2	25869016/1	1	TUBO	TUBE	TUBE	ROHR
3	18375051/1	2	FASCETTA	FAIR-LED	FIXATION DE CABLE	KABELBEFESTIGUNG
4	12735108/0	3	VITE	SCREW	VIS	SCHRAUBE
5	12154210/0	1	DADO	NUT	ECROU	MUTTER
6	12691115/0	1	VITE	SCREW	VIS	SCHRAUBE
7	12540260/0	1	RONDELLA	WASHER	RONDELLE	SCHEIBE
8	27598060/0	1	PROLUNGA SCARICO OLIO	OIL DISCHARGE EXTENSION	EXTENSION DECH. HUILE	ÖL ABFLUSS
9	18737849/0	1	TAPPO PROLUNGA	OIL CAP	BOUCHON HUILE	OELVERSCHLUSS
10	18401001/1	1	GUARNIZIONE	OIL SEAL	GARNITURE	DICHTUNG
11	18738227/0	1	TUBO SCARICO	EXHAUST TUBE	TUBE ECHAPPEMENT	ABGASUNGROHR
12	12735530/0	2	VITE	SCREW	VIS	SCHRAUBE
13	12583500/0	2	GROWER	GROWER	GROWER	GROWER
14	25160035/0	3	DISTANZIALE	SPACER	ENTRETOISE	ENTFERNUNGSSTÜCK
31	82750004/0	1	SILENZIATORE	MUFFLER	SILENCEUX	AUSPUFF
32	12793102/0	2	VITE	SCREW	VIS	SCHRAUBE
33	12540260/0	2	RONDELLA	WASHER	RONDELLE	SCHEIBE
34	12360425/0	2	DADO	NUT	ECROU	MUTTER
35	82598029/0	1	PROTEZIONE	GUARD	PROTECTION	SCHUTZE
36	12792611/0	2	VITE	SCREW	VIS	SCHRAUBE
37	12583500/0	2	GROWER	GROWER	GROWER	GROWER

PER LA SOSTITUZIONE DELLE PARTI CONTRASSEGNALE CON «\*» RIVOLGERSI AL SERVIZIO ASSISTENZA DEL COSTRUTTORE DEL MOTORE.  
 TO REPLACE THE PARTS MARKED «\*» SEEK ASSISTANCE FROM THE ENGINE MANUFACTURER'S AFTER SALES SERVICE.  
 POUR LE REMPLACEMENT DES PIÈCES MARQUÉES AVEC «\*» S'ADRESSER AU SERVICE APRÈS VENTES DU CONSTRUCTEUR DU MOTEUR.  
 ZUM AUSTAUSCH DER MIT «\*» GEKENNZEICHNETEN TEILE, WENDEN SIE SICH AN DEN KUNDENDIENST DES HERSTELLERS DES MOTOR.

TC

TCP

TCR

TCB

TCX

TX

102

102 hydro

122 hydro

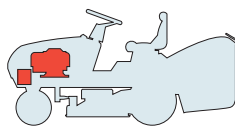

MOTORE  
ENGINE  
MOTEUR  
MOTOR  
KOHLER 22 HP

**KOHLER**<sup>®</sup>

2006

005j.0

1 / 1

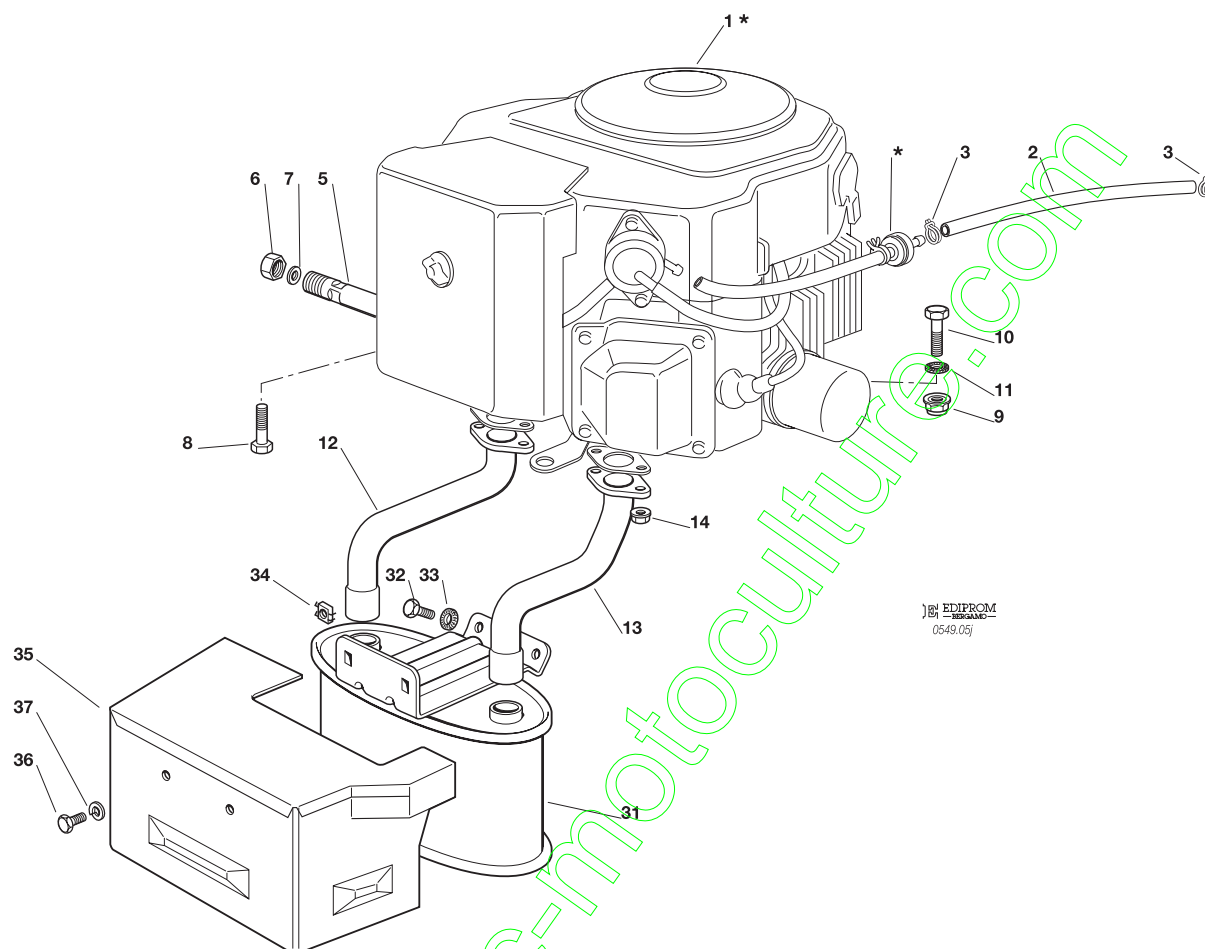

EDIPROM  
0549.05j

N.	CODE	Q.TY	DESCRIZIONE	DESCRIPTION	DESCRIPTION	BESCHREIBUNG
1*	—	1	MOTORE	ENGINE	MOTEUR	MOTOR
2	25869016/1	1	TUBO COLLEGAMENTO	CONNECTING TUBE	TUBE DE CONNEXION	VERBINDUNGSGROHR
3	18375051/1	2	FASCETTA	FAIR LED	FIXATION DE CABLE	KABELBEFESTIGUNG
5	25598050/0	1	PROLUNGA SCARICO OLIO	OIL DISCHARGE EXTENSION	EXTENSION RALLONGE DE DECH. HUILE	ÖL ENTLEERUNGSVERLAENGERUNG
6	18737849/0	1	TAPPO PROLUNGA	OIL CAP	BOUCHON HUILE	OELVERSCHLUSS
7	18401001/1	1	GUARNIZIONE	OIL SEAL	GARNITURE	DICHTUNG
8	12735109/0	3	VITE	SCREW	VIS	SCHRAUBE
9	12154210/0	1	DADO	NUT	ECROU	MUTTER
10	12691115/0	1	VITE	SCREW	VIS	SCHRAUBE
11	12540260/0	1	RONDELLA	WASHER	RONDELLE	SCHEIBE
12	18738207/1	1	TUBO SCARICO DESTRO	EXHAUST TUBE RIGHT	TUBE ECHAPPEMENT DROIT	ABGASUNGROHR, RECHTE
13	18738208/1	1	TUBO SCARICO SINISTRO	EXHAUST TUBE LEFT	TUBE ECHAPPEMENT GAU.	ABGASUNGROHR, LINKE
14	12293201/0	4	DADO	NUT	ECROU	MUTTER
31	82750003/0	1	SILENZIATORE	MUFFLER	SILENCEUX	AUSPUFF
32	12793102/0	2	VITE	SCREW	VIS	SCHRAUBE
33	12540260/0	2	RONDELLA	WASHER	RONDELLE	SCHEIBE
34	12360425/0	2	DADO	NUT	ECROU	MUTTER
35	82598013/1	1	PROTEZIONE	GUARD	PROTECTION	SCHUTZE
36	12792611/0	2	VITE	SCREW	VIS	SCHRAUBE
37	12583500/0	2	GROWER	GROWER	GROWER	GROWER

PER LA SOSTITUZIONE DELLE PARTI CONTRASSEGNALE CON «\*» RIVOLGERSI AL SERVIZIO ASSISTENZA DEL COSTRUTTORE DEL MOTORE.  
TO REPLACE THE PARTS MARKED «\*» SEEK ASSISTANCE FROM THE ENGINE MANUFACTURER'S AFTER SALES SERVICE.  
POUR LE REMPLACEMENT DES PIÈCES MARQUÉES AVEC «\*» S'ADRESSER AU SERVICE APRÈS VENTES DU CONSTRUCTEUR DU MOTEUR.  
ZUM AUSTAUSCH DER MIT «\*» GEKENNZEICHNETEN TEILE, WENDEN SIE SICH AN DEN KUNDENDIENST DES HERSTELLERS DES MOTOR.

TC	TCP	TCR	TCB	TCX	TX
102	102 hydro	102 hydro	102 hydro	122 hydro	122 hydro

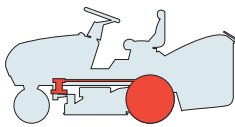

TRASMISSIONE  
TRANSMISSION  
TRANSMISSION  
GETRIEBE

2006
006M.0
1 / 2

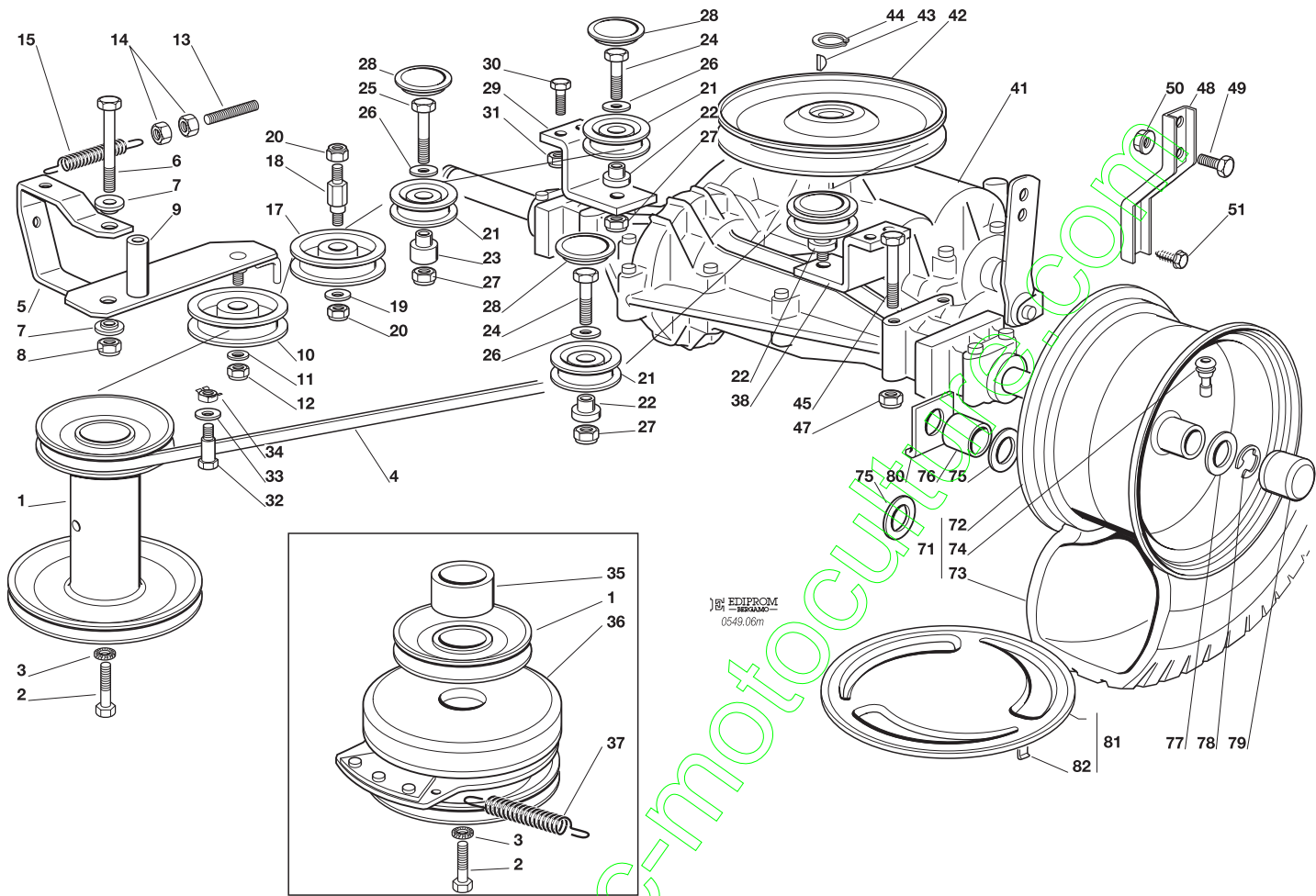

N.	CODE	Q.TY	DESCRIZIONE	DESCRIPTION	DESCRIPTION	BESCHREIBUNG
----	------	------	-------------	-------------	-------------	--------------

3	12543000/0	1	ROSETTA	WASHER	RONDELLE	SCHEIBE
4	35062011/0	1	CINGHIA	BELT	COURROIE	RIEMEN
5	82318165/1	1	LEVA	LEVER	LEVIER	HEBEL
6	12692000/0	1	VITE	SCREW	VIS	SCHRAUBE
7	25038002/1	2	BOCCOLA	BUSH	DOUILLE	BÜCHSE
8	12155000/0	1	DADO	NUT	ECROU	MUTTER
9	25160027/0	1	DISTANZIALE	SPACER	ENTRETOISE	ENTFERNUNGSSTÜCK
10	25601554/0	1	PULEGGIA	PULLEY	POULIE	RIEMENSCHLEIBE
11	12523060/0	1	RONDELLA	WASHER	RONDELLE	SCHEIBE
12	12155000/0	1	DADO	NUT	ECROU	MUTTER
13	25840010/1	1	TIRANTE	TIE ROD	TIRANT	SPANNSTANGE
14	12293200/0	2	DADO	NUT	ECROU	MUTTER
15	25430219/0	1	MOLLA	SPRING	RESSORT	FEDER
17	25601555/0	1	PULEGGIA	PULLEY	POULIE	RIEMENSCHLEIBE
18	25510036/1	1	PERNO	PIN	PIVOT	BOLZEN
19	12523060/0	1	RONDELLA	WASHER	RONDELLE	SCHEIBE
20	12155000/0	2	DADO	NUT	ECROU	MUTTER
21	25601570/0	4	PULEGGIA	PULLEY	POULIE	RIEMENSCHLEIBE
22	25160018/0	3	DISTANZIALE CORTO	SHORT SPACER	ENTRETOISE COURT	KURZ ABSTANDSSTÜCK
23	25160024/1	1	DISTANZIALE LUNGO	LONG SPACER	ENTRETOISE LONGUE	LANG ABSTANDSSTÜCK
24	12691100/0	3	VITE	SCREW	VIS	SCHRAUBE
25	12691400/0	1	VITE	RIGHT SCREW	VIS	SCHRAUBE
26	12523060/0	4	RONDELLA	WASHER	RONDELLE	SCHEIBE
27	12155000/0	4	DADO	NUT	ECROU	MUTTER
28	25109521/1	4	COPERCHIO	COVER	COUVERCLE	DECKEL
29	25785125/0	1	STAFFA	CLAMP	ETRIER	BRIDE
30	12791213/1	4	VITE	RIGHT SCREW	VIS	SCHRAUBE
31	12154510/0	4	DADO	NUT	ECROU	MUTTER
32	25580018/0	2	PIOLO GUIDACINGHIA	BELT GUIDE	GUIDE DE COURROIRE	RIEMENFÜHRUNG
33	12523060/0	2	ROSETTA	WASHER	RONDELLE	SCHEIBE
34	12360425/0	2	DADO	NUT	ECROU	MUTTER







N.	CODE	Q.TY	DESCRIZIONE	DESCRIPTION	DESCRIPTION	BESCHREIBUNG
38	25785125/0	1	STAFFA <b>(Peerless)</b>	CLAMP <b>(Peerless)</b>	ETRIER <b>(Peerless)</b>	BRIDE <b>(Peerless)</b>
	25785227/0	1	STAFFA <b>(Dana)</b>	CLAMP <b>(Dana)</b>	ETRIER <b>(Dana)</b>	BRIDE <b>(Dana)</b>
41*	18400940/0	1	ASSE POSTERIORE <b>Tecumseh-Peerless MST 205-554</b>	REAR AXLE <b>Tecumseh-Peerless MST 205-554</b>	AXE ARRIERE <b>Tecumseh-Peerless MST 205-554</b>	HINTERACHSE <b>Tecumseh-Peerless MST 205-554</b>
*	18400942/0	1	ASSE POSTERIORE <b>Dana</b>	REAR AXLE <b>Dana</b>	AXE ARRIERE <b>Dana</b>	HINTERACHSE <b>Dana</b>
42	82601503/0	1	PULEGGIA	PULLEY	POULIE	RIEMENSCHLEIBE
43	12139430/0	1	LINGUETTA	KEY	CLAVETTE	KEIL
44	12608950/0	1	ANELLO ELASTICO	SNAP RING	ANNEAU RESSORT	SPRENGRING
45	12691800/0	4	VITE <b>(Peerless)</b>	SCREW <b>(Peerless)</b>	VIS <b>(Peerless)</b>	SCHRAUBE <b>(Peerless)</b>
	12691900/0	4	VITE <b>(Dana)</b>	SCREW <b>(Dana)</b>	VIS <b>(Dana)</b>	SCHRAUBE <b>(Dana)</b>
47	12154210/0	4	DADO	NUT	ECROU	MUTTER
48	25774285/0	2	STAFFA	CLAMP	ETRIER	BRIDE
49	12792611/0	2	VITE	SCREW	VIS	SCHRAUBE
50	12293201/0	2	DADO	NUT	ECROU	MUTTER
51	12735150/0	2	VITE	SCREW	VIS	SCHRAUBE
71	82680003/0	2	RUOTA POSTERIORE TURF SAVER CARLISLE	REAR WHEEL TURF SAVER CARLISLE	ROUE ARRIERE TURF SAVER CARLISLE	HINTERRAD TURF SAVER CARLISLE
	82680006/0		DELI TIRE	DELI TIRE	DELI TIRE	DELI TIRE
72	82000592/0	2	CERCHIO RUOTA	RIMM	BANDAGE ROUE	HINTERRAD FELGER
73	25590001/0	2	PNEUMATICO TURF SAVER CARLISLE	SHOE TURF SAVER CARLISLE	PNEU TURF SAVER CARLISLE	REIFEN TURF SAVER CARLISLE
	25590003/0		DELI TIRE	DELI TIRE	DELI TIRE	DELI TIRE
74	25950000/0	2	VALVOLA	VALVE	SOUPAPE	VENTIL
75	12521410/0	0-4	RONDELLA	WASHER	RONDELLE	SCHEIBE
76	25160028/0	2	DISTANZIALE <b>(Peerless)</b>	SPACER <b>(Peerless)</b>	ENTRETOISE <b>(Peerless)</b>	ENTFERNUNGSSTÜCK <b>(Peerless)</b>
	25160031/0	2	DISTANZIALE <b>(Dana)</b>	SPACER <b>(Dana)</b>	ENTRETOISE <b>(Dana)</b>	ENTFERNUNGSSTÜCK <b>(Dana)</b>
77	25670005/1	2	RONDELLA	WASHER	RONDELLE	SCHEIBE
78	12001010/0	2	ANELLO ELASTICO	SNAP RING	ANNEAU RESSORT	SPRENGRING
79	22110230/0	2	COPRIMOZZO	HUB COVER	COUVRE MOYEU	NABEDECKEL
80	25670017/0	2	RONDELLA <b>(Dana)</b>	WASHER <b>(Dana)</b>	RONDELLE <b>(Dana)</b>	SCHEIBE <b>(Dana)</b>
81	82110253/0	2	COPRIRUOTA POSTERIORE <b>(TCP - TCB)</b>	REAR WHEEL DECK <b>(TCP - TCB)</b>	COUVRE ROUE POST. <b>(TCP - TCB)</b>	HINTERRADDECKEL <b>(TCP - TCB)</b>
82	25430209/0	8	MOLLA AGGANCIAMENTO	SPRING	RESSORT	FEDER
			<b>Nei modelli con innesto delle lame a leva:</b>	<b>For models with engagement of the blades by lever:</b>	<b>Dans les modèles avec embrayage des lames à levier:</b>	<b>Bei Modellen mit Hebelschaltung der Messer:</b>
1	25601569/0	1	PULEGGIA	PULLEY	POULIE	RIEMENSCHLEIBE
2	12737310/0	1	VITE	SCREW	VIS	SCHRAUBE
			<b>Nei modelli con innesto delle lame elettromagnetico:</b>	<b>For models with engagement of the blades by electromagnetic clutch:</b>	<b>Dans les modèles avec embrayage des lames électromagnétique:</b>	<b>Bei Modellen mit elektromagnetischer Schaltung der Messer:</b>
1	25601567/0	1	PULEGGIA	PULLEY	POULIE	RIEMENSCHLEIBE
2	12737320/0	1	VITE	SCREW	VIS	SCHRAUBE
35	25160021/0	1	DISTANZIALE	SPACER	ENTRETOISE	ENTFERNUNGSSTÜCK
36	18399060/0	1	FRIZIONE	CLUTC	EMBRAJAGE	KUPPLUNG
37	25430210/0	1	MOLLA	SPRING	RESSORT	FEDER

PER LA SOSTITUZIONE DELLE PARTI CONTRASSEGNALE CON «\*» RIVOLGERSI AL SERVIZIO ASSISTENZA DEL COSTRUTTORE DELLA TRASMISSIONE.  
TO REPLACE THE PARTS MARKED «\*» SEEK ASSISTANCE FROM THE TRANSMISSION MANUFACTURER'S AFTER SALES SERVICE.  
POUR LE REMPLACEMENT DES PIÈCES MARQUÉES AVEC «\*» S'ADRESSER AU SERVICE APRÈS VENTES DU CONSTRUCTEUR DE LA TRANSMISSION.  
ZUM AUSTAUSCH DER MIT «\*» GEKENNZEICHNETEN TEILE, WENDEN SIE SICH AN DEN KUNDENDIENST DES HERSTELLERS DES ANTRIEBS.

TC	TCP	TCR	TCB	TCX	TX
102	102 hydro	102 hydro			

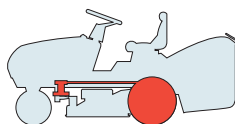

TRASMISSIONE  
TRANSMISSION  
TRANSMISSION  
GETRIEBE

2006
006Y.0
1 / 2

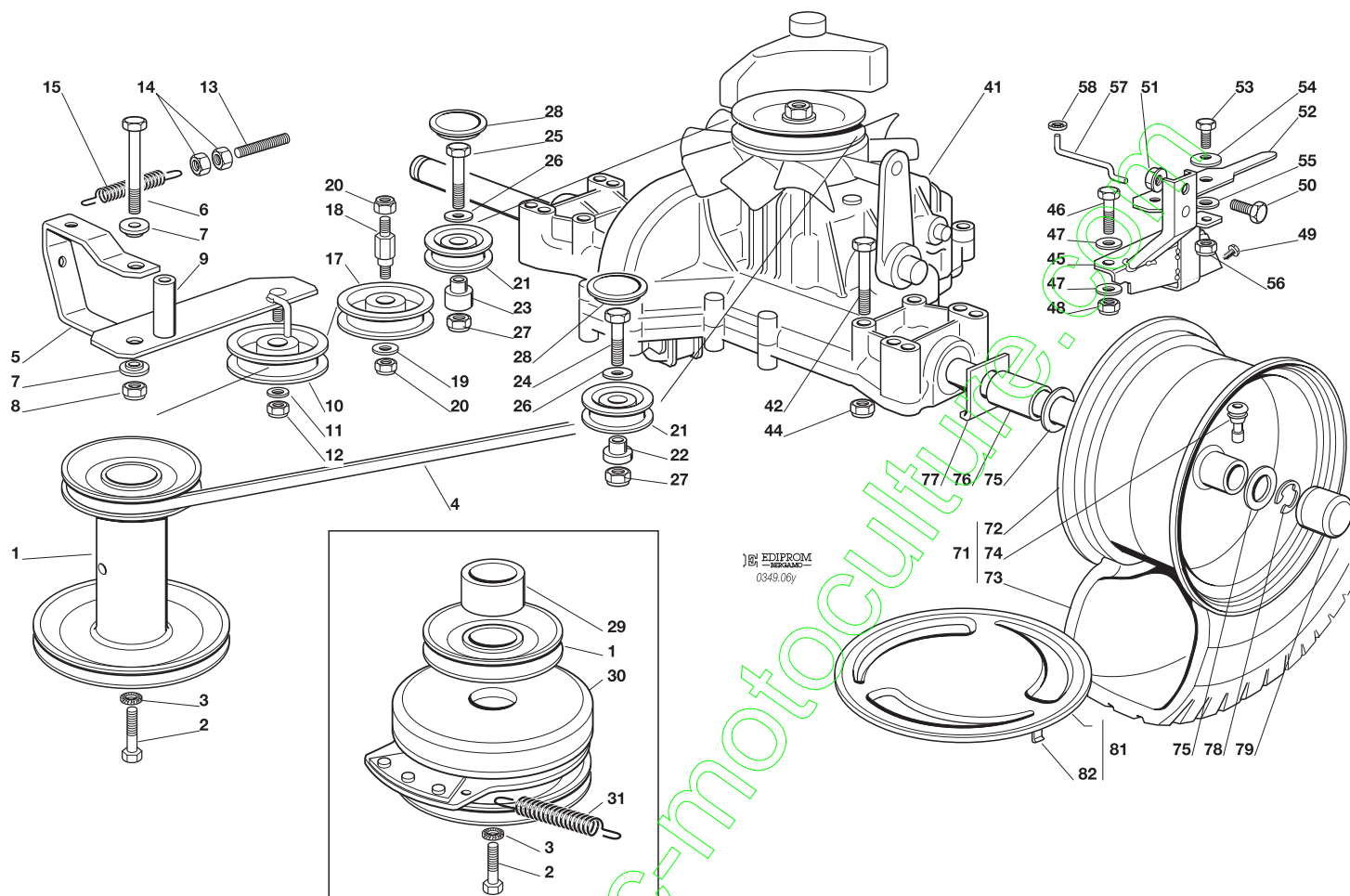

N.	CODE	Q.TY	DESCRIZIONE	DESCRIPTION	DESCRIPTION	BESCHREIBUNG
3	12543000/0	1	ROSETTA	WASHER	RONDELLE	SCHEIBE
4	35062001/0	1	CINGHIA	BELT	COURROIE	RIEMEN
5	82318165/1	1	LEVA	LEVER	LEVIER	HEBEL
6	12692000/0	1	VITE	SCREW	VIS	SCHRAUBE
7	25038002/1	2	BOCCOLA	BUSH	DOUILLE	BÜCHSE
8	12155000/0	1	DADO	NUT	ECROU	MUTTER
9	25160027/0	1	DISTANZIALE	SPACER	ENTRETOISE	ENTFERNUNGSSTÜCK
10	25601554/0	1	PULEGGIA	PULLEY	POULIE	RIEMENSCHLEIBE
11	12523060/0	1	RONDELLA	WASHER	RONDELLE	SCHEIBE
12	12155000/0	1	DADO	NUT	ECROU	MUTTER
13	25840010/1	1	TIRANTE	TIE ROD	TIRANT	SPANNSTANGE
14	12293200/0	2	DADO	NUT	ECROU	MUTTER
15	25430219/0	1	MOLLA	SPRING	RESSORT	FEDER
17	25601555/0	1	PULEGGIA	PULLEY	POULIE	RIEMENSCHLEIBE
18	25510036/1	1	PERNO	PIN	PIVOT	BOLZEN
19	12523060/0	1	RONDELLA	WASHER	RONDELLE	SCHEIBE
20	12155000/0	2	DADO	NUT	ECROU	MUTTER
21	25601570/0	2	PULEGGIA	PULLEY	POULIE	RIEMENSCHLEIBE
22	25160030/0	1	DISTANZIALE SINISTRO	LEFT SPACER	ENTRETOISE GAUCHE	LINKER ABSTANDSSTÜCK
23	25160024/1	1	DISTANZIALE DESTRO	RIGHT SPACER	ENTRETOISE DROITE	RECHTER ABSTANDSSTÜCK
24	12691115/0	1	VITE	SCREW	VIS	SCHRAUBE
25	12691400/0	1	VITE	RIGHT SCREW	VIS	SCHRAUBE
26	12523060/0	2	RONDELLA	WASHER	RONDELLE	SCHEIBE
27	12155000/0	2	DADO	NUT	ECROU	MUTTER
28	25109521/1	2	COPERCHIO	COVER	COUVERCLE	DECKEL
41*	18400950/1	1	ASSE POSTERIORE <b>Tuff Torq K46F</b>	REAR AXLE <b>Tuff Torq K46F</b>	AXE ARRIERE <b>Tuff Torq K46F</b>	HINTERACHSE <b>Tuff Torq K46F</b>
42	12691800/0	4	VITE	SCREW	VIS	SCHRAUBE
44	12154210/0	4	DADO	NUT	ECROU	MUTTER



N.	CODE	Q.TY	DESCRIZIONE	DESCRIPTION	DESCRIPTION	BESCHREIBUNG
45	82785109/0	1	SUPPORTO	SUPPORT	SUPPORT	HALTER
46	12691200/0	1	VITE	SCREW	VIS	SCHRAUBE
47	12521350/0	2	RONDELLA	WASHER	RONDELLE	SCHEIBE
48	12155000/0	1	DADO	NUT	ECROU	MUTTER
49	12735120/0	2	VITE	SCREW	VIS	SCHRAUBE
50	12792611/0	1	VITE	SCREW	VIS	SCHRAUBE
51	12293201/0	1	DADO	NUT	ECROU	MUTTER
52	25318157/0	1	LEVA	LEVER	LEVIER	HEBEL
53	12793102/0	1	VITE	SCREW	VIS	SCHRAUBE
54	12369500/0	1	DISCO ELASTICO	ELASTIC WASHER	DISQUE ELASTIQUE	FEDERSCHEIBE
55	25670011/0	1	RONDELLA	WASHER	RONDELLE	SCHEIBE
56	12155000/0	1	DADO	NUT	ECROU	MUTTER
57	25033033/0	1	ASTA	ROD	BARRE	STANGE
58	12604896/0	1	FISSATORE A CORONA	CROWN FASTENER	FIXATEUR A COURONNE	KRONESCHEIBE
71	•	2	RUOTA POSTERIORE	REAR WHEEL	ROUE ARRIERE	HINTERRAD
	82680003/0		TURF SAVER CARLISLE	TURF SAVER CARLISLE	TURF SAVER CARLISLE	TURF SAVER CARLISLE
	82680006/0		DELI TIRE	DELI TIRE	DELI TIRE	DELI TIRE
72	82000592/0	2	CERCHIO RUOTA	RIMM	BANDAGE ROUE	HINTERRAD FELGER
73	•	2	PNEUMATICO	SHOE	PNEU	REIFEN
	25590001/0		TURF SAVER CARLISLE	TURF SAVER CARLISLE	TURF SAVER CARLISLE	TURF SAVER CARLISLE
	25590003/0		DELI TIRE	DELI TIRE	DELI TIRE	DELI TIRE
74	25950000/0	2	VALVOLA	VALVE	SOUPAPE	VENTIL
75	25670005/1	4	RONDELLA	WASHER	RONDELLE	SCHEIBE
76	25160023/0	2	DISTANZIALE	SPACER	ENTRETOISE	ENTFERNUNGSSTÜCK
77	25670017/0	2	RONDELLA	WASHER	RONDELLE	SCHEIBE
78	12001010/0	2	ANELLO ELASTICO	SNAP RING	ANNEAU RESSORT	SPRENGRING
79	22110230/0	2	COPRIMOZZO	HUB COVER	COUVRE MOYEU	NABEDECKEL
81	82110253/0	2	COPRIRUOTA POSTERIORE (TCP - TCB)	REAR WHEEL DECK (TCP - TCB)	COUVRE ROUE POST. (TCP - TCB)	HINTERRADDECKEL (TCP - TCB)
82	25430209/0	8	MOLLA AGGANCI	SPRING	RESSORT	FEDER
			<b>Nei modelli con innesto delle lame a leva:</b>	<b>For models with engagement of the blades by lever:</b>	<b>Dans les modèles avec embrayage des lames à levier:</b>	<b>Bei Modellen mit Hebelschaltung der Messer:</b>
1	25601568/0	1	PULEGGIA	PULLEY	POULIE	RIEMENSCHLEIBE
2	12737310/0	1	VITE	SCREW	VIS	SCHRAUBE
			<b>Nei modelli con innesto delle lame elettromagnetico:</b>	<b>For models with engagement of the blades by electromagnetic clutch:</b>	<b>Dans les modèles avec embrayage des lames électromagnétique:</b>	<b>Bei Modellen mit elektromagnetischer Schaltung der Messer:</b>
1	25601566/0	1	PULEGGIA	PULLEY	POULIE	RIEMENSCHLEIBE
2	12737320/0	1	VITE	SCREW	VIS	SCHRAUBE
29	25160021/0	1	DISTANZIALE	SPACER	ENTRETOISE	ENTFERNUNGSSTÜCK
30	18399060/0	1	FRIZIONE	CLUTC	EMBRAJAGE	KUPPLUNG
31	25430210/0	1	MOLLA	SPRING	RESSORT	FEDER

PER LA SOSTITUZIONE DELLE PARTI CONTRASSEGNALE CON «\*» RIVOLGERSI AL SERVIZIO ASSISTENZA DEL COSTRUTTORE DELLA TRASMISSIONE.  
 TO REPLACE THE PARTS MARKED «\*» SEEK ASSISTANCE FROM THE TRANSMISSION MANUFACTURER'S AFTER SALES SERVICE.  
 POUR LE REMPLACEMENT DES PIÉCES MARQUÉES AVEC «\*» S'ADRESSER AU SERVICE APRÈS VENTES DU CONSTRUCTEUR DE LA TRANSMISSION.  
 ZUM AUSTAUSCH DER MIT «\*» GEKENNZEICHNETEN TEILE, WENDEN SIE SICH AN DEN KUNDENDIENST DES HERSTELLERS DES ANTRIEBS.

TC	TCP	TCR	TCB	TCX	TX
102	102 hydro	102 hydro	102 hydro	122 hydro	122 hydro

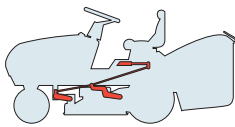

SOLLEVAMENTO PIATTO DI TAGLIO  
CUTTING PLATE LIFTING  
SOULEVEMENT PLATEAU DE COUPE  
SCHNEIDWERKZEUG AUFHEBESATZ

2006  
007.0  
1 / 2

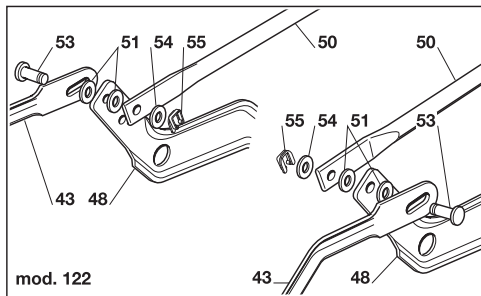

mod. 122

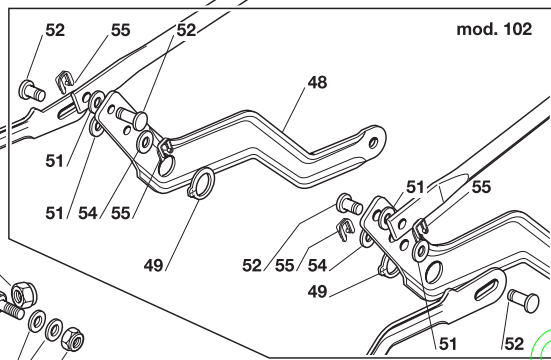

mod. 102

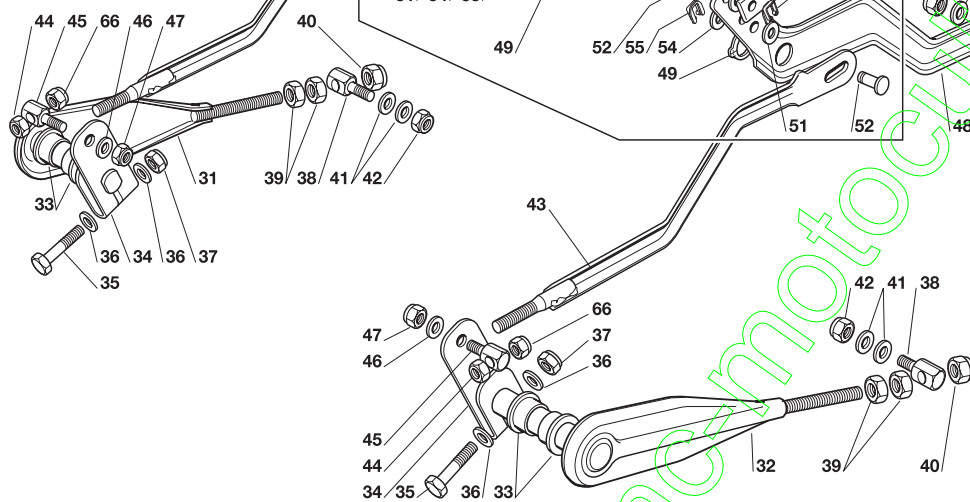

EDIPROM  
0349.07

N.	CODE	Q.TY	DESCRIZIONE	DESCRIPTION	DESCRIPTION	BESCHREIBUNG
----	------	------	-------------	-------------	-------------	--------------

1	82300002/1	1	ASSIEME LEVA (2 ÷ 9)	LEVER ASS.Y (2 ÷ 9)	ENS. LEVIER (2 ÷ 9)	AUFHEBENHEBEL (2 ÷ 9)
2	82318139/0	1	LEVA	LEVER	LEVIER	HEBEL
3	25605000/1	1	PULSANTE	BUTTON	POUSSOIR	DRUCKKNOPF
4	25470901/0	1	NASELLO	DOG	DECLIC	NASE
5	25510011/0	1	PERNO	PIN	PIVOT	BOLZEN
6	25033002/0	1	ASTA	ROD	TIGE	STAB
7	25394504/1	1	MANOPOLA	KNOB	POIGNEE	GRIF
8	25430208/0	1	MOLLA	SPRING	RESSORT	FEDER
9	12604899/0	1	FISSATORE A CORONA	CROWN FASTENER	FIXATEUR A COURONNE	KRONESCHEIBE
10	82000479/0	1	ASSE	AXLE	AXE	ACHSE
11	22034523/0	3	BOCCOLA	BUSH	DOUILLE	BÜCHSE
12	25160025/0	1	DISTANZIALE	SPACER	ENTRETOISE	ENTFERNUNGSSTÜCK
13	22672153/0	1	RONDELLA	WASHER	RONDELLE	SCHEIBE
14	12521410/0	1	RONDELLA	WASHER	RONDELLE	SCHEIBE
15	12609260/0	1	SEEGER	SEEGER	SEEGER	SEEGER
16	12620206/0	2	SPINA	PIN	GOUPILLE	STIFT
17	25735506/1	1	SETTORE	SECTOR	SECTEUR	SEKTOR
18	12792611/0	2	VITE	SCREW	VIS	SCHRAUBE
19	12293201/0	2	DADO	NUT	ECROU	MUTTER
31	82318155/0	1	LEVA ANTERIORE DESTRA <i>(mod. 102)</i>	FRONT RIGHT LEVER <i>(mod. 102)</i>	LEVIER ANT. DROITE <i>(mod. 102)</i>	RECHTER VORDERHEBEL <i>(mod. 102)</i>
	82318159/0	1	LEVA ANTERIORE DESTRA <i>(mod. 122)</i>	FRONT RIGHT LEVER <i>(mod. 122)</i>	LEVIER ANT. DROITE <i>(mod. 122)</i>	RECHTER VORDERHEBEL <i>(mod. 122)</i>
32	82318157/0	1	LEVA ANTERIORE SINISTRA <i>(mod. 102)</i>	FRONT LEFT LEVER <i>(mod. 102)</i>	LEVIER ANT. GAUCHE <i>(mod. 102)</i>	LINKER VORDERHEBEL <i>(mod. 102)</i>
	82318161/0	1	LEVA ANTERIORE SINISTRA <i>(mod. 122)</i>	FRONT LEFT LEVER <i>(mod. 122)</i>	LEVIER ANT. GAUCHE <i>(mod. 122)</i>	LINKER VORDERHEBEL <i>(mod. 122)</i>
33	25040605/0	4	BUSSOLA	BUSH	DOUILLE	BÜCHSE
34	25318161/0	2	LEVA	LEVER	LEVIER	HEBEL
35	12691700/0	2	VITE	SCREW	VIS	SCHRAUBE







N.	CODE	Q.TY	DESCRIZIONE	DESCRIPTION	DESCRIPTION	BESCHREIBUNG
36	12521350/0	4	RONDELLA	WASHER	RONDELLE	SCHEIBE
37	12155000/0	2	DADO	NUT	ECROU	MUTTER
38	25510056/0	2	PERNO	PIN	PIVOT	BOLZEN
39	12295200/0	4	DADO	NUT	ECROU	MUTTER
40	12156602/0	2	DADO	NUT	ECROU	MUTTER
41	25670008/1	4	RONDELLA	WASHER	RONDELLE	SCHEIBE
42	12156602/0	2	DADO	NUT	ECROU	MUTTER
43	82000477/2	2	ASTA COLLEGAMENTO	CONNECTING ROD	TIGE DE CONNEXION	VERBINDUNGSSTAB
44	12155000/0	2	DADO	NUT	ECROU	MUTTER
45	25510055/0	2	PERNO	PIN	PIVOT	BOLZEN
46	12521350/0	2	RONDELLA	WASHER	RONDELLE	SCHEIBE
47	12155000/0	2	DADO	NUT	ECROU	MUTTER
48	25318153/1	2	LEVA POSTERIORE	REAR LEVER	LEVIER ARRIERE	HINTERHEBEL
49	12609255/0	2	SEEGER	SEEGER	SEEGER	SEEGER
50	25033029/0	2	ASTA COLLEGAMENTO	CONNECTING ROD	TIGE DE CONNEXION	VERBINDUNGSSTAB
51	25670011/0	6	RONDELLA	WASHER	RONDELLE	SCHEIBE
52	25510053/1	6	PERNO (mod. 102)	PIN (mod. 102)	PIVOT (mod. 102)	BOLZEN (mod. 102)
		2	PERNO (mod. 122)	PIN (mod. 122)	PIVOT (mod. 122)	BOLZEN (mod. 122)
53	25510048/0	2	PERNO (mod. 122)	PIN (mod. 122)	PIVOT (mod. 122)	BOLZEN (mod. 122)
54	12521350/0	2	RONDELLA	WASHER	RONDELLE	SCHEIBE
55	12436050/0	6	PIASTRINA (mod. 102)	PLATE (mod. 102)	PLAQUETTE (mod. 102)	PLATTE (mod. 102)
		4	PIASTRINA (mod. 122)	PLATE (mod. 122)	PLAQUETTE (mod. 122)	PLATTE (mod. 122)
56	25510056/0	2	PERNO	PIN	PIVOT	BOLZEN
57	25670008/1	4	RONDELLA	WASHER	RONDELLE	SCHEIBE
58	12156602/0	2	DADO	NUT	ECROU	MUTTER
59	12794980/0	2	VITE	SCREW	VIS	SCHRAUBE
60	12295200/0	2	DADO	NUT	ECROU	MUTTER
61	25510070/0	2	PERNO	PIN	PIVOT	BOLZEN
62	12523090/0	2	RONDELLA	WASHER	RONDELLE	SCHEIBE
63	24487998/0	2	COPPIGLIA	COTTER PIN	GOUPILLE	SPLIT
64	25430218/0	1	MOLLA	SPRING	RESSORT	FEDER
66	12293200/0	2	DADO	NUT	ECROU	MUTTER

contact@emc-motoculture.com

TC	TCP	TCR	TCB	TCX	TX
102	102 hydro	102 hydro	102 hydro	122 hydro	122 hydro

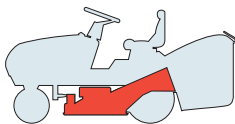

PIATTO DI TAGLIO (1)  
 CUTTING PLATE (1)  
 PLATEAU DE COUPE (1)  
 SCHNEIDWERKZEUG (1)

2006
008.0
1 / 2

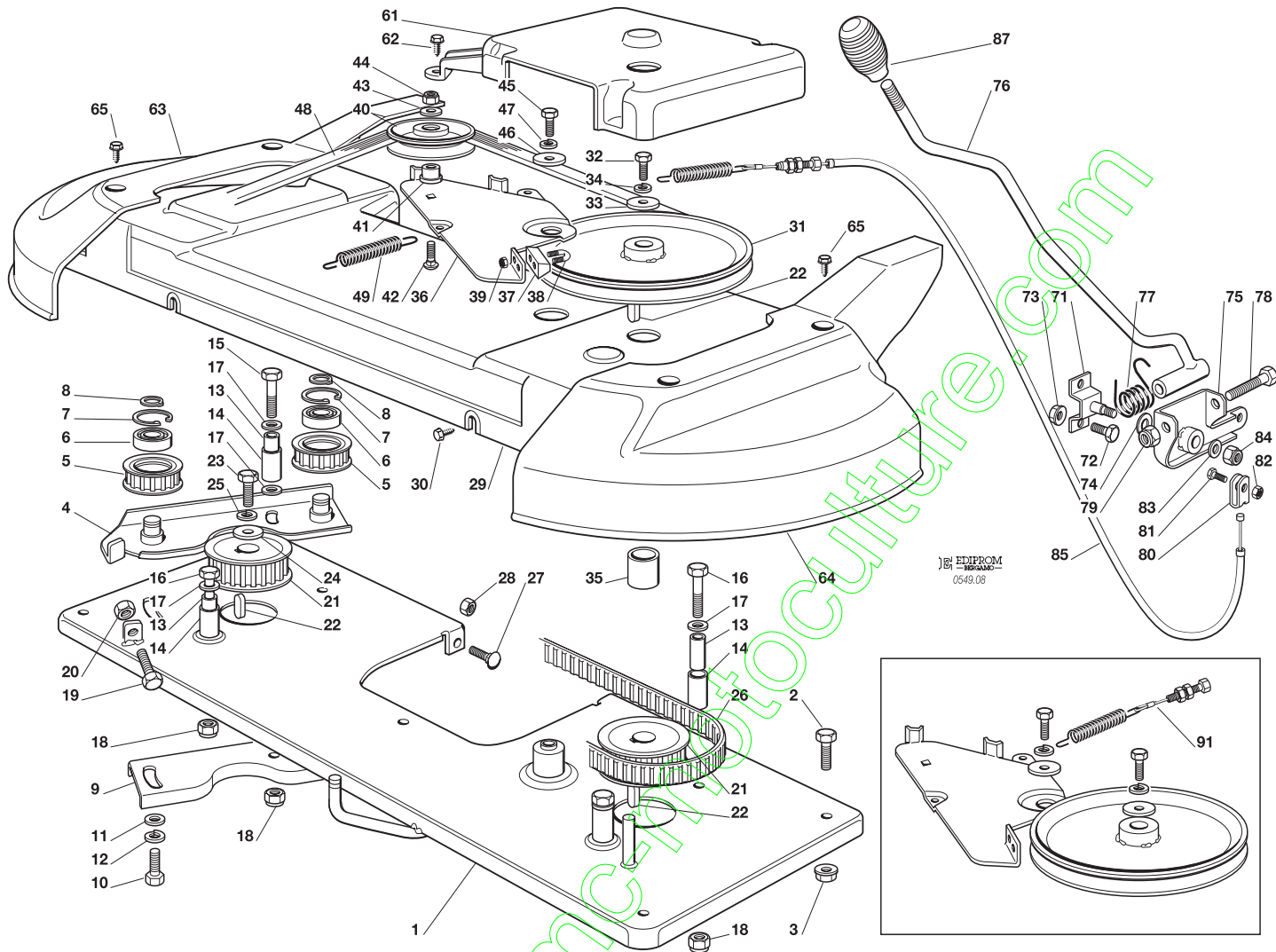

N.	CODE	Q.TY	DESCRIZIONE	DESCRIPTION	DESCRIPTION	BESCHREIBUNG
----	------	------	-------------	-------------	-------------	--------------

1	82547003/2	1	PIASTRA (mod. 102)	PLATE (mod. 102)	PLATE (mod. 102)	PLATTE (mod. 102)
	82547005/1	1	PIASTRA (mod. 122)	PLATE (mod. 122)	PLATE (mod. 122)	PLATTE (mod. 122)
2	12792611/0	4	VITE	SCREW	VIS	SCHRAUBE
3	12293201/0	4	DADO	NUT	ECROU	MUTTER
4	82785084/1	1	SUPPORTO	SUPPORT	SUPPORT	HALTERSATZ
5	25601559/1	2	PULEGGIA (mod. 102)	PULLEY (mod. 102)	POULIE (mod. 102)	RIEMENSCHLEIBE (mod. 102)
	25601561/0	2	PULEGGIA (mod. 122)	PULLEY (mod. 122)	POULIE (mod. 122)	RIEMENSCHLEIBE (mod. 122)
6	19216033/1	2	CUSCINETTO	BEARING	ROULEMENT	KUEGELLAGER
7	12610800/0	2	SEEGER	SEEGER	SEEGER	SEEGER
8	12609200/0	2	SEEGER	SEEGER	SEEGER	SEEGER
9	25650037/0	1	RINFORZO	STIFFENING	REINFORCEMENT	VERSTAERKUNG
10	12793102/0	2	VITE	SCREW	VIS	SCHRAUBE
11	12521350/0	2	RONDELLA	WASHER	RONDELLE	SCHEIBE
12	12583500/0	2	GROWER	GROWER	GROWER	GROWER
13	25160003/0	4	DISTANZIALE	SPACER	ENTRETOISE	DISTANZRING
14	25038000/0	4	BUCCOLA	BUSHING	DOUILLE	BUCHSE
15	12691700/0	1	VITE	SCREW	VIS	SCHRAUBE
16	12691200/0	3	VITE	SCREW	VIS	SCHRAUBE
17	12521350/0	5	RONDELLA	WASHER	RONDELLE	SCHEIBE
18	12155000/0	4	DADO	NUT	ECROU	MUTTER
19	12793900/0	1	VITE	SCREW	VIS	SCHRAUBE
20	12293200/0	1	DADO	NUT	ECROU	MUTTER
21	25601560/0	2	PULEGGIA (mod. 102)	PULLEY (mod. 102)	POULIE (mod. 102)	RIEMENSCHLEIBE (mod. 102)
	25601562/0	2	PULEGGIA (mod. 122)	PULLEY (mod. 122)	POULIE (mod. 122)	RIEMENSCHLEIBE (mod. 122)
22	12139480/0	3	CHIAVETTA	KEY	CLAVETTE	KEIL
23	12793102/0	1	VITE	SCREW	VIS	SCHRAUBE
24	25670007/0	1	RONDELLA	WASHER	RONDELLE	SCHEIBE
25	12583500/0	1	GROWER	GROWER	GROWER	GROWER



N.	CODE	Q.TY	DESCRIZIONE	DESCRIPTION	DESCRIPTION	BESCHREIBUNG
26	35065600/0	1	CINGHIA (mod. 102)	BELT (mod. 102)	COURROIRE (mod. 102)	KEILRIEMEN (mod. 102)
	35065601/0	1	CINGHIA (mod. 122)	BELT (mod. 122)	COURROIRE (mod. 122)	KEILRIEMEN (mod. 122)
27	12815200/0	3	VITE	SCREW	VIS	SCHRAUBE
28	12292102/0	3	DADO	NUT	ECROU	MUTTER
29	25060100/3	1	CARTER (mod. 102)	CASE (mod. 102)	CARTER (mod. 102)	BLECH (mod. 102)
	25060101/2	1	CARTER (mod. 122)	CASE (mod. 122)	CARTER (mod. 122)	BLECH (mod. 122)
30	12735110/0	6	VITE	SCREW	VIS	SCHRAUBE
31	25601550/0	1	PULEGGIA (mod. 102)	PULLEY (mod. 102)	POULIE (mod. 102)	RIEMENSCHLEIBE (mod. 102)
	25601549/0	1	PULEGGIA (mod. 122)	PULLEY (mod. 122)	POULIE (mod. 122)	RIEMENSCHLEIBE (mod. 122)
32	12793102/0	1	VITE	SCREW	VIS	SCHRAUBE
33	25670007/0	1	RONDELLA	WASHER	RONDELLE	SCHLEIBE
34	12583500/0	1	GROWER	GROWER	GROWER	GROWER
35	25160002/0	1	DISTANZIALE	SPACER	ENTRETOISE	DISTANZRING
36	25318115/1	1	LEVA FRENO (mod. 102)	BRAKE LEVER (mod. 102)	LEVIER FREIN (mod. 102)	BREMSHEBEL (mod. 102)
	25318119/0	1	LEVA FRENO (mod. 122)	BRAKE LEVER (mod. 122)	LEVIER FREIN (mod. 122)	BREMSHEBEL (mod. 122)
40	25601555/0	1	PULEGGIA	PULLEY	POULIE	RIEMENSCHLEIBE
41	25160007/0	1	DISTANZIALE	SPACER	ENTRETOISE	DISTANZRING
42	12818900/0	1	VITE	SCREW	VIS	SCHRAUBE
43	12523060/0	1	RONDELLA	WASHER	RONDELLE	SCHLEIBE
44	12155000/0	1	DADO	NUT	ECROU	MUTTER
45	12793102/0	1	VITE	SCREW	VIS	SCHRAUBE
46	12523070/0	1	RONDELLA	WASHER	RONDELLE	SCHLEIBE
47	12583500/0	1	GROWER	GROWER	GROWER	GROWER
48	35062813/0	1	CINGHIA (mod. 102)	BELT (mod. 102)	COURROIE (mod. 102)	KEIL RIEMEN (mod. 102)
	35062814/0	1	CINGHIA (mod. 122)	BELT (mod. 122)	COURROIE (mod. 122)	KEIL RIEMEN (mod. 122)
61	25600049/0	1	PROTEZIONE (mod. 102)	GUARD (mod. 102)	PROTECTION (mod. 102)	SCHUTZ (mod. 102)
	25600050/0	1	PROTEZIONE (mod. 122)	GUARD (mod. 122)	PROTECTION (mod. 122)	SCHUTZ (mod. 122)
62	12735403/0	3	VITE	SCREW	VIS	SCHRAUBE
63	25060113/0	1	CARTER (TCX)	GUARD (TCX)	CARTER (TCX)	BLECH (TCX)
64	25060114/0	1	CARTER (TCX)	GUARD (TCX)	CARTER (TCX)	BLECH (TCX)
65	12735403/0	4	VITE (TCX)	SCREW (TCX)	VIS (TCX)	SCHRAUBE (TCX)

*Nei modelli con innesto delle lame a leva:*

*For models with engagement of the blades by lever:*

*Dans les modèles avec em-brayage des lames à levier:*

*Bei Modellen mit Hebelschaltung der Messer:*

37	25207000/1	1	FERODO	LINING	PASTILLE FREIN	BREMSBELAG
38	25270317/0	1	CAVALLOTTO	U-BOLT	VIS À CAVALIER	U-SCHRAUBE
39	12154330/0	2	DADO	NUT	ECROU	MUTTER
48	35062813/0	1	CINGHIA (mod. 102)	BELT (mod. 102)	COURROIE (mod. 102)	KEIL RIEMEN (mod. 102)
	35062814/0	1	CINGHIA (mod. 122)	BELT (mod. 122)	COURROIE (mod. 122)	KEIL RIEMEN (mod. 122)
49	25430210/0	1	MOLLA (mod. 102)	SPRING (mod. 102)	RESSORT (mod. 102)	FEDER (mod. 102)
	25430220/0	1	MOLLA (mod. 122)	SPRING (mod. 122)	RESSORT (mod. 122)	FEDER (mod. 122)
71	82774227/0	1	SUPPORTO	SUPPORT	SUPPORT	HALTER
72	12792611/0	2	VITE	SCREW	VIS	SCHRAUBE
73	12293201/0	2	DADO	NUT	ECROU	MUTTER
74	22672151/0	1	RONDELLA	WASHER	RONDELLE	SCHLEIBE
75	82774229/0	1	STAFFA	CLAMP	BRIDE	BRIDE
76	82318177/1	1	LEVA	LEVER	LEVIER	HEBEL
77	25430227/0	1	MOLLA	SPRING	RESSORT	FEDER
78	12692050/0	1	VITE	SCREW	VIS	SCHRAUBE
79	12155000/0	1	DADO	NUT	ECROU	MUTTER
80	22061337/0	1	CAVALLOTTO	CONNECTING PLATE	PAQUE DE CONNEXION	BUGEL BOLZEN
81	12791213/1	1	VITE	SCREW	VIS	SCHRAUBE
82	12154510/0	1	DADO	NUT	ECROU	MUTTER
83	12523060/0	1	RONDELLA	WASHER	RONDELLE	SCHLEIBE
84	12155010/0	1	DADO	NUT	ECROU	MUTTER
85	82004616/0	1	FILO (mod. 102)	WIRE (mod. 102)	FIL (mod. 102)	KABEL (mod. 102)
	82004607/1	1	FILO (mod. 122)	WIRE (mod. 122)	FIL (mod. 122)	KABEL (mod. 122)
87	25394510/0	1	MANOPOLA	KNOB	POIGNEE	GRIFF

*Nei modelli con innesto delle lame elettromagnetico:*

*For models with engagement of the blades by electromagnetic clutch:*

*Dans les modèles avec embrayage des lames électromagnétique:*

*Bei Modellen mit elektromagnetischer Schaltung der Messer:*

48	35062811/0	1	CINGHIA (mod. 102)	BELT (mod. 102)	COURROIE (mod. 102)	KEIL RIEMEN (mod. 102)
	35062812/0	1	CINGHIA (mod. 122)	BELT (mod. 122)	COURROIE (mod. 122)	KEIL RIEMEN (mod. 122)
91	82004608/0	1	FILO (mod. 102)	WIRE (mod. 102)	FIL (mod. 102)	KABEL (mod. 102)
	82004609/0	1	FILO (mod. 122)	WIRE (mod. 122)	FIL (mod. 122)	KABEL (mod. 122)

TC	TCP	TCR	TCB	TCX	TX
102	102 hydro	102 hydro	102 hydro	122 hydro	122 hydro

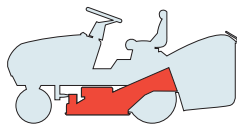

PIATTO DI TAGLIO (2)  
CUTTING PLATE (2)  
PLATEAU DE COUPE (2)  
SCHNEIDWERKZEUG (2)

2006
009.0
1 / 2

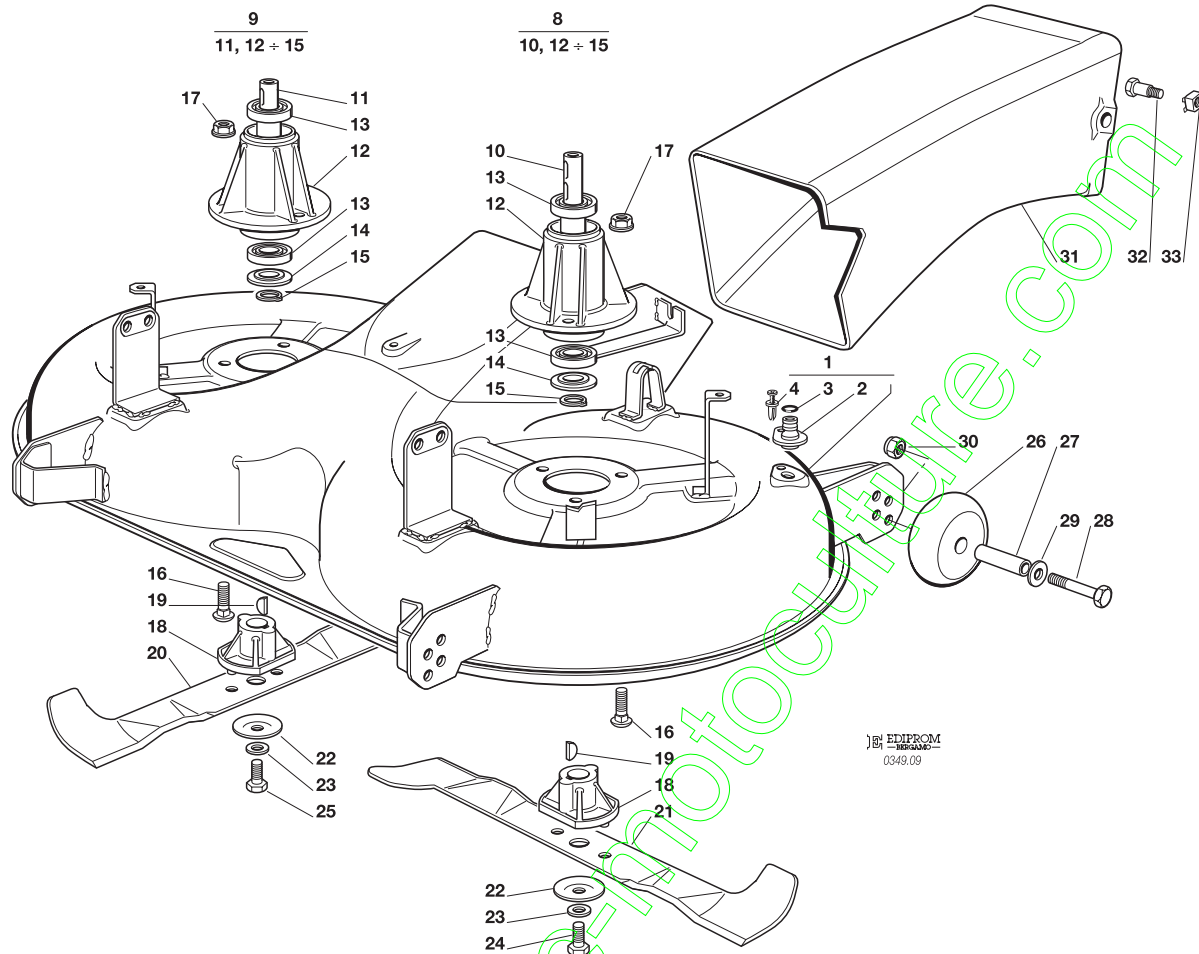

N.	CODE	Q.TY	DESCRIZIONE	DESCRIPTION	DESCRIPTION	BESCHREIBUNG
1	82565025/0	1	ASSIEME PIATTO DI TAGLIO (CON 2 - 3 - 4) (mod. 102)	CUTTING PLATE ASS.Y (WITH 2 - 3 - 4) (mod. 102)	ENS. PLATEAU DE COUPE (AVEC 2 - 3 - 4) (mod. 102)	SCHNEIDWERKZEUG (MIT 2 - 3 - 4) (mod. 102)
	82565026/1	1	ASSIEME PIATTO DI TAGLIO (CON 2 - 3 - 4) (mod. 122)	CUTTING PLATE ASS.Y (WITH 2 - 3 - 4) (mod. 122)	ENS. PLATEAU DE COUPE (AVEC 2 - 3 - 4) (mod. 122)	SCHNEIDWERKZEUG (MIT 2 - 3 - 4) (mod. 122)
2	25033060/0	2	ATTACCO TUBO ACQUA	WATER HOSE CONNECTION	RACCORD TUYAU D'EAU	WASSERANSCHLUSS
3	19035000/0	2	ANELLO OR	O RING	O RING	O RING
4	12500030/0	2	RIVETTO	RIVET	RIVET	NIET
8	82207200/1	1	ASS. FLANGIA ALBERO PRINCIPALE (10, 12÷15)	BLADE MAIN SHAFT SUPPORT (10, 12÷15)	SUPPORT ARBRE LAME PRINCIPAL (10, 12÷15)	MASSERWELLEHAFTSATZ (10, 12÷15)
9	82207201/2	1	ASS. FLANGIA ALBERO SECONDARIO (11, 12÷15)	BLADE SECONDARY SHAFT SUPPORT (11, 12÷15)	SUPPORT ARBRE LAME SECONDAIRE (11, 12÷15)	MASSERWELLE ZWEITERSATZ (11, 12÷15)
10	25020800/1	1	ALBERO LAMA PRINCIPALE	MAIN BLADE SHAFT	ARBRE LAME PRINCIPAL	HAUP MESSERWELLE
11	25020801/2	1	ALBERO LAMA SECONDARIO	SECONDARY BLADE SHAFT	ARBRE LAME SECONDAIRE	ZWEITE MESSERWELLE
12	25207200/0	2	FLANGIA ALBERO LAMA	BLADE SHAFT SUPPORT	SUPPORT ARBRE LAME	MESSERWELLE
13	19216032/0	4	CUSCINETTO	BEARING	ROULEMENT	KUEGELLAGER
14	25160501/0	2	DISCO PARAPOLVERE	DUST COVER	PROTEGE-POUSSIERE	STAUBSCHUTTSCHIEBE
15	12609260/0	2	SEEGER	SEEGER	SEEGER	SEEGER
16	12818700/0	6	VITE	SCREW	VIS	SCHRAUBE
17	12154210/0	6	DADO	NUT	ECROU	MUTTER
18	25463200/0	2	MOZZO COLTELLO	BLADE HUB	MOYEU LAME	MESSERHALTER
19	12139100/0	2	LINGUETTA	KEY	CLAVETTE	KEIL
20	82004348/0	1	COLTELLO DX (mod. 102)	RIGHT BLADE (mod. 102)	LAME DROITE (mod. 102)	RECHTER MESSER (mod. 102)
	82004350/0	1	COLTELLO DX (mod. 122)	RIGHT BLADE (mod. 122)	LAME DROITE (mod. 122)	RECHTER MESSER (mod. 122)
21	82004347/0	1	COLTELLO SX (mod. 102)	LEFT BLADE (mod. 102)	LAME GAUCHE (mod. 102)	LINKER MESSER (mod. 102)
	82004349/0	1	COLTELLO SX (mod. 122)	LEFT BLADE (mod. 122)	LAME GAUCHE (mod. 122)	LINKER MESSER (mod. 122)
22	22160400/0	2	DISCO ELASTICO	ELASTIC WASHER	RONDELLE ELASTIQUE	FEDERSCHIEBE
23	12523080/0	2	RONDELLA	WASHER	RONDELLE	SCHEIBE
24	12735694/0	1	VITE	SCREW	VIS	SCHRAUBE
25	12735695/1	1	VITE	SCREW	VIS	SCHRAUBE
26	82700002/0	4	RUOTINO ANTISCALPO	ANTI SCALP WHEEL	ROULETTES ANTISCALP	SKALPIERSCHUTZRÄDCHEN





N.	CODE	Q.TY	DESCRIZIONE	DESCRIPTION	DESCRIPTION	BESCHREIBUNG
27	25510072/0	4	DISTANZIALE	SPACER	ENTRETOISE	ENTFERNUNGSSTÜCK
28	12692050/0	4	VITE	SCREW	VIS	SCHRAUBE
29	12523060/0	4	RONDELLA	WASHER	RONDELLE	SCHEIBE
30	12293201/0	4	DADO	NUT	ECROU	MUTTER
31	25108009/0	1	CONVOGLIATORE POSTER.	REAR CONVEYOR ASS.Y	ENS. CONVOYEUR POST.	HINTERLEITBLECHSATZ
32	25510051/0	2	VITE	SCREW	VIS	SCHRAUBE
33	12360425/0	2	DADO	NUT	ECROU	MUTTER
			<b>Nei modelli con innesto delle lame a leva:</b>	<b>For models with engagement of the blades by lever:</b>	<b>Dans les modèles avec em-brayage des lames à levier:</b>	<b>Bei Modellen mit Hebelschaltung der Messer:</b>
—	82565023/0	1	PIATTO DI TAGLIO ASSEMBLATO (mod. 102) (008, 1÷62 + 009a, 1÷30)	CUTTING PLATE, ASSEMBLED (mod. 102) (008, 1÷62 + 009a, 1÷30)	PLATEAU DE COUPE, COMPLETE (mod. 102) (008, 1÷62 + 009a, 1÷30)	SCHNEIDWERKZEUG, KOMPLETT (mod. 102) (008, 1÷62 + 009a, 1÷30)
—	82565024/0	1	PIATTO DI TAGLIO ASSEMBLATO (mod. 122) (008, 1÷62 + 009a, 1÷30)	CUTTING PLATE, ASSEMBLED (mod. 122) (008, 1÷62 + 009a, 1÷30)	PLATEAU DE COUPE, COMPLETE (mod. 122) (008, 1÷62 + 009a, 1÷30)	SCHNEIDWERKZEUG, KOMPLETT (mod. 122) (008, 1÷62 + 009a, 1÷30)
			<b>Nei modelli con innesto delle lame elettromagnetico:</b>	<b>For models with engagement of the blades by electromagnetic clutch:</b>	<b>Dans les modèles avec embrayage des lames électromagnétique:</b>	<b>Bei Modellen mit elektro-magnetischer Schaltung der Messer:</b>
—	82565027/0	1	PIATTO DI TAGLIO ASSEMBLATO (mod. 102) (008, 1÷62 + 009a, 1÷30)	CUTTING PLATE, ASSEMBLED (mod. 102) (008, 1÷62 + 009a, 1÷30)	PLATEAU DE COUPE, COMPLETE (mod. 102) (008, 1÷62 + 009a, 1÷30)	SCHNEIDWERKZEUG, KOMPLETT (mod. 102) (008, 1÷62 + 009a, 1÷30)
—	82565028/0	1	PIATTO DI TAGLIO ASSEMBLATO (mod. 122) (008, 1÷62 + 009a, 1÷30)	CUTTING PLATE, ASSEMBLED (mod. 122) (008, 1÷62 + 009a, 1÷30)	PLATEAU DE COUPE, COMPLETE (mod. 122) (008, 1÷62 + 009a, 1÷30)	SCHNEIDWERKZEUG, KOMPLETT (mod. 122) (008, 1÷62 + 009a, 1÷30)

contact@emc-motors.com

TC	TCP	TCR	TCB	TCX	TX
----	-----	-----	-----	-----	----

102

102 hydro

122 hydro

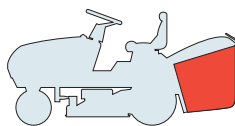

**SACCO  
GRASSCATCHER  
BAC  
AUFFANGSACK**

2006

010.0

1 / 2

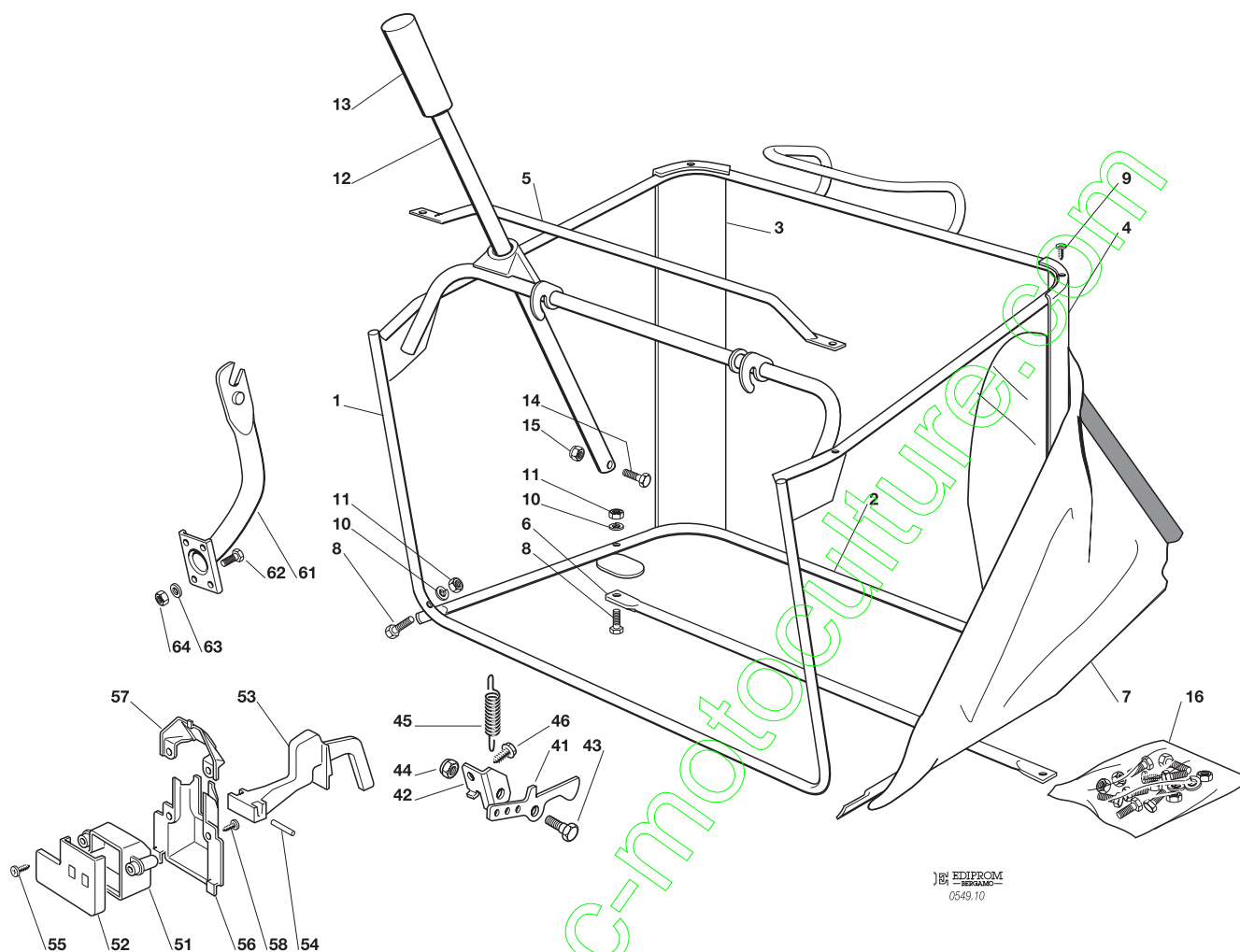

EDIPROM  
0549.10

N.	CODE	Q.TY	DESCRIZIONE	DESCRIPTION	DESCRIPTION	BESCHREIBUNG
1	82800051/0	1	TELAIO SUPERIORE	UPPER FRAME	CHASSIS SUPERIEUR	OBERERRAHMEN
2	82800002/2	1	TELAIO INFERIORE	LOWER FRAME	CHASSIS INFERIEUR	UNTERERRAHMEN
3	25032001/1	1	ANGOLARE DESTRO	RIGHT ANGULAR SUPPORT	SUPPORT ANG. DROITE	RECHTER HALTER
4	25032002/1	1	ANGOLARE SINISTRO	LEFT ANGULAR SUPPORT	SUPPORT ANG. GAUCHE	LINKER HALTER
5	82394001/2	1	MANIGLIA ANTERIORE	FRONT HANDLE	POIGNEE ANTERIEURE	VORDERGRIF
6	82650038/0	1	RINFORZO INFERIORE	LOWER STIFFENING	RENFORCEMENT SUPER.	OBERE VERSTAERKUNG
7	82106000/2	1	SACCO	GRASSCATCHER	SAC	SACK
8	12792099/0	4	VITE	SCREW	VIS	SCHRAUBE
9	12729601/1	4	VITE	SCREW	VIS	SCHRAUBE
10	12582101/0	4	GROWER	GROWER	GROWER	GROWER
11	12292100/0	4	DADO	NUT	ECROU	MUTTER
12	25869029/1	1	TUBO	ROD	TIGE	STANGE
13	25394508/0	1	MANOPOLA	HANDLE	POINGEE	GRIF
14	12792099/0	1	VITE	SCREW	VIS	SCHRAUBE
15	12154510/0	1	DADO	NUT	ECROU	MUTTER
16	82180027/1	1	DOTAZIONE VITERIA (8÷15)	SCREWS OUTFIT (8÷15)	ENSEMBLE DES VIS (8÷15)	SCHRAUBENAUSRÜSTUNG (8÷15)
41	25774315/0	1	STAFFA	BRACKET	ETRIER	BRIDE
42	25755031/0	1	SQUADRETTA	BRACKET	EQUERRE-SUPPORT	WINKEL
43	25510080/0	1	PERNO	PIN	PIVOT	BOLZEN
44	12292102/0	1	DADO	NUT	ECROU	MUTTER
45	25430210/0	1	MOLLA	SPRING	RESSORT	FEDER
46	12735122/0	1	VITE	SCREW	VIS	SCHRAUBE
51	25600041/0	1	PROTEZIONE MICRO	MICRO PROTECTION	PROTECTION MICRO	SCHUTZ
52	25600042/0	1	COPERCHIO PROTEZIONE	PROTECTION COVER	COUVERCLE PROTECTION	SCHUTZDEKEL
53	25318124/0	1	LEVA	LEVER	LEVIER	HEBEL
54	12400030/0	1	SPINA	PIN	GOUPILLE	STIFT
55	12728510/0	1	VITE	SCREW	VIS	SCHRAUBE





N.	CODE	Q.TY	DESCRIZIONE	DESCRIPTION	DESCRIPTION	BESCHREIBUNG
56	25600047/0	1	PROTEZIONE MICRO	MICRO PROTECTION	PROTECTION MICRO	SCHUTZ
57	25600048/0	1	COPERCHIO PROTEZIONE	PROTECTION COVER	COUVERCLE PROTECTION	SCHUTZDEKEL
58	12728450/0	2	VITE	SCREW	VIS	SCHRAUBE
61	82774225/1	2	SUPPORTO	SUPPORT	SUPPORT	HALTER
62	12793102/0	6	VITE	SCREW	VIS	SCHRAUBE
63	12523060/0	6	RONDELLA	WASHER	RONDELLE	SCHEIBE
64	12293201/0	6	DADO	NUT	ECROU	MUTTER

contact@enc-motoculture.com

TC	TCP	TCR	TCB	TCX	TX
102	102 hydro	122 hydro			

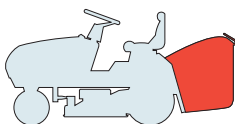

**SACCO  
GRASSCATCHER  
BAC  
AUFFANGSACK**

2006
<b>010a.0</b>
1 / 2

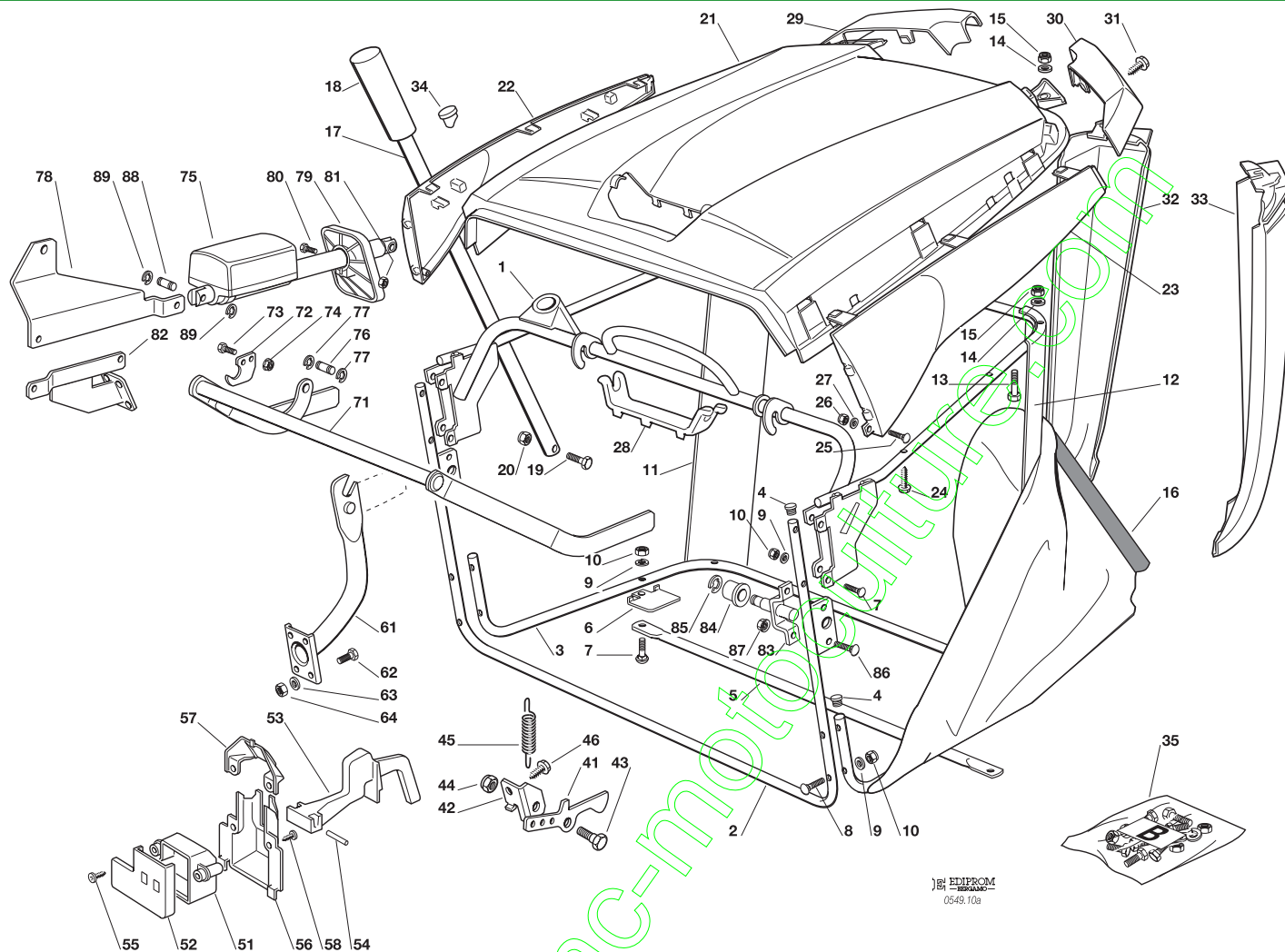

EDIPROM  
0549.10a

N.	CODE	Q.TY	DESCRIZIONE	DESCRIPTION	DESCRIPTION	BESCHREIBUNG
----	------	------	-------------	-------------	-------------	--------------

1	82800079/0	1	TELAIO SUPERIORE	UPPER FRAME	CHASSIS SUPERIEUR	OBERERRAHMEN
2	82800089/0	1	TELAIO BOCCA SACCO	FRONT FRAME	CHASSIS AVANT	VORDERRAHMEN
3	25808017/0	1	TELAIO INFERIORE	LOWER FRAME	CHASSIS INFERIEUR	UNTERERRAHMEN
4*	18566110/0	4	PUNTALE	CAP	EMBOUT	DRUCKSTÜCK
5	82650043/0	1	RINFORZO INFERIORE	LOWER STIFFENING	RENFORCEMENT SUPER.	OBERE VERSTAERKUNG
6*	25547131/0	1	PIASTRINA	PLATE	PLAQUE	PLATTE
7*	12815220/0	6	VITE	SCREW	VIS	SCHRAUBE
8*	12815245/0	4	VITE	SCREW	VIS	SCHRAUBE
9*	12521330/0	10	RONDELLA	WASHER	RONDELLE	SCHEIBE
10*	12154510/0	10	DADO	NUT	ECROU	MUTTER
11	25032013/0	1	ANGOLARE DESTRO	RIGHT ANGULAR SUPPORT	SUPPORT ANG. DROITE	RECHTER HALTER
12	25032015/0	1	ANGOLARE SINISTRO	LEFT ANGULAR SUPPORT	SUPPORT ANG. GAUCHE	LINKER HALTER
13*	12689500/0	4	VITE	SCREW	VIS	SCHRAUBE
14*	12521330/0	8	RONDELLA	WASHER	RONDELLE	SCHEIBE
15*	12154510/0	8	DADO	NUT	ECROU	MUTTER
16	82105982/0	1	SACCO	GRASSCATCHER	SAC	SACK
17	25869029/1	1	TUBO	ROD	TIGE	STANGE
18	25394508/0	1	MANOPOLA	HANDLE	POINGEE	GRIF
19*	12674550/0	1	VITE	SCREW	VIS	SCHRAUBE
20*	12154510/0	1	DADO	NUT	ECROU	MUTTER
21	25110302/0	1	COPERTURA SACCO	GRASS-CATCHER COVER	COUVRE-BAC	SACKKAPPE
22	25032015/0	1	COPERTURA LATERALE DX.	RIGHT COVER	COUVRE DRO.	SCHACHT KAPPE
23	25109746/0	1	COPERTURA LATERALE SX.	LEFT COVER	COUVRE GAU.	LINKE KAPPE
24*	12735410/0	4	VITE	SCREW	VIS	SCHRAUBE
25*	12815220/0	2	VITE	SCREW	VIS	SCHRAUBE
26*	12521330/0	2	RONDELLA	WASHER	RONDELLE	SCHEIBE
27*	12154510/0	2	DADO	NUT	ECROU	MUTTER
28	25394009/0	1	COPERTURA MANIGLIA	HANDLE COVER	COUVRE-POINGEE	GRIFFKAPPE
29	25207126/0	1	COPERCHIO ANGOLARE DX.	RIGHT COVER	COUVRE DRO.	RECHTE KAPPE
30	25207127/0	1	COPERCHIO ANGOLARE SX.	LEFT COVER	COUVRE GAU.	LINKE KAPPE
31*	12735403/0	4	VITE	SCREW	VIS	SCHRAUBE







N.	CODE	Q.TY	DESCRIZIONE	DESCRIPTION	DESCRIPTION	BESCHREIBUNG
32	25032006/0	1	ANGOLARE DX.	RIGHT ANGLE	CORNIERE DRO.	RECHTES WINKELPROFIL
33	25032007/0	1	ANGOLARE SX.	LEFT ANGLE	CORNIERE GAU.	LINKES WINKELPROFIL
41	25774315/0	1	STAFFA	BRACKET	ETRIER	BRIDE
42	25755031/0	1	SQUADRETTA	BRACKET	EQUERRE-SUPPORT	WINKEL
43	25510080/0	1	PERNO	PIN	PIVOT	BOLZEN
44	12292102/0	1	DADO	NUT	ECROU	MUTTER
45	25430210/0	1	MOLLA	SPRING	RESSORT	FEDER
46	12735122/0	1	VITE	SCREW	VIS	SCHRAUBE
51	25600041/0	1	PROTEZIONE MICRO	MICRO PROTECTION	PROTECTION MICRO	SCHUTZ
52	25600042/0	1	COPERCHIO PROTEZIONE	PROTECTION COVER	COUVERCLE PROTECTION	SCHUTZDEKEL
53	25318124/0	1	LEVA	LEVER	LEVIER	HEBEL
54	12400030/0	1	SPINA	PIN	GOUPILLE	STIFT
55	12728510/0	1	VITE	SCREW	VIS	SCHRAUBE
56	25600047/0	1	PROTEZIONE MICRO	MICRO PROTECTION	PROTECTION MICRO	SCHUTZ
57	25600048/0	1	COPERCHIO PROTEZIONE	PROTECTION COVER	COUVERCLE PROTECTION	SCHUTZDEKEL
58	12728450/0	2	VITE	SCREW	VIS	SCHRAUBE
62*	12793102/0	6	VITE	SCREW	VIS	SCHRAUBE
63*	12523060/0	6	RONDELLA	WASHER	RONDELLE	SCHEIBE
64*	12293201/0	6	DADO	NUT	ECROU	MUTTER
			<b>Modelli con sollevamento manuale:</b>	<b>Models with manual tipping:</b>	<b>Modèles avec renversement manuelle:</b>	<b>Modellen mit Handbedienung:</b>
35	82180037/2	1	DOTAZIONE VITERIA (COMPRENDE *)	SCREWS OUTFIT (INCLUDING *)	ENSEMBLE DES VIS (COMPRENANT *)	SCHRAUBENAUSRÜSTUNG (MITGELIEFERTEN *)
61	82774225/1	2	SUPPORTO	SUPPORT	SUPPORT	HALTER
			<b>Modelli con sollevamento elettrico:</b>	<b>Models with electric tipping:</b>	<b>Modèles avec renversement électrique:</b>	<b>Modellen mit elektrischer Bedienung:</b>
34◆	25120232/0	1	TAPPO	CAP	BOUCHON	VERSCHLUSS
35	82180038/1	1	DOTAZIONE VITERIA (COMPRENDE * E ◆)	SCREWS OUTFIT (INCLUDING * AND ◆)	ENSEMBLE DES VIS (COMPRENANT * ET ◆)	SCHRAUBENAUSRÜSTUNG (MITGELIEFERTEN * UND ◆)
61	82774245/0	2	SUPPORTO	SUPPORT	SUPPORT	HALTER
71	82000507/0	1	ASSE SOLLEVAMENTO	AXLE	AXE	ACHSE
72◆	25774317/0	2	PIASTRINA	PLATE	PLAQUE	PLATTE
73◆	12815210/0	4	VITE	SCREW	VIS	SCHRAUBE
74◆	12154510/0	4	DADO	NUT	ECROU	MUTTER
75	18001000/0	1	ATTUATORE	ACTUATOR	ACTUATEUR	AKTUATOR
76◆	25510083/0	1	PERNO	PIN	PIVOT	BOLZEN
77◆	12000955/0	2	BENZING	BENZING	BENZING	BENZING
78	25785197/0	1	SUPPORTO ATTUATORE	SUPPORT	SUPPORT	HALTER
79	25600060/0	1	PROTEZIONE ATTUATORE	PROTECTION	PROTECTION	SCHUTZ
80	12727795/0	1	VITE	SCREW	VIS	SCHRAUBE
81	12154330/0	1	DADO	NUT	ECROU	MUTTER
82	82650209/0	1	RINFORZO	STIFFENING	REINFORCEMENT	VERSTAERKUNG
83◆	82785147/0	2	SUPPORTO FULCRO	SUPPORT	SUPPORT	HALTER
84◆	25690001/0	2	RULLINO	ROLL	ROULEAU	WALZE
85◆	12000956/0	2	BENZING	BENZING	BENZING	BENZING
86◆	12818690/0	4	VITE	SCREW	VIS	SCHRAUBE
87◆	12293201/0	4	DADO	NUT	ECROU	MUTTER
88	25510083/0	1	PERNO	PIN	PIVOT	BOLZEN
89	12000955/0	2	BENZING	BENZING	BENZING	BENZING

TC	TCP	TCR	TCB	TCX	TX
102	102 hydro	102 hydro	102 hydro	122 hydro	122 hydro

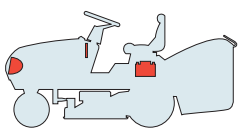

**PARTI ELETTRICHE**  
**ELECTRICAL PARTS**  
**PARTIES ELECTRIQUES**  
**ELETRISCHE TEILE**  
**B&S - TECUMSEH - KOHLER**

2006
<b>011.0</b>
1 / 2

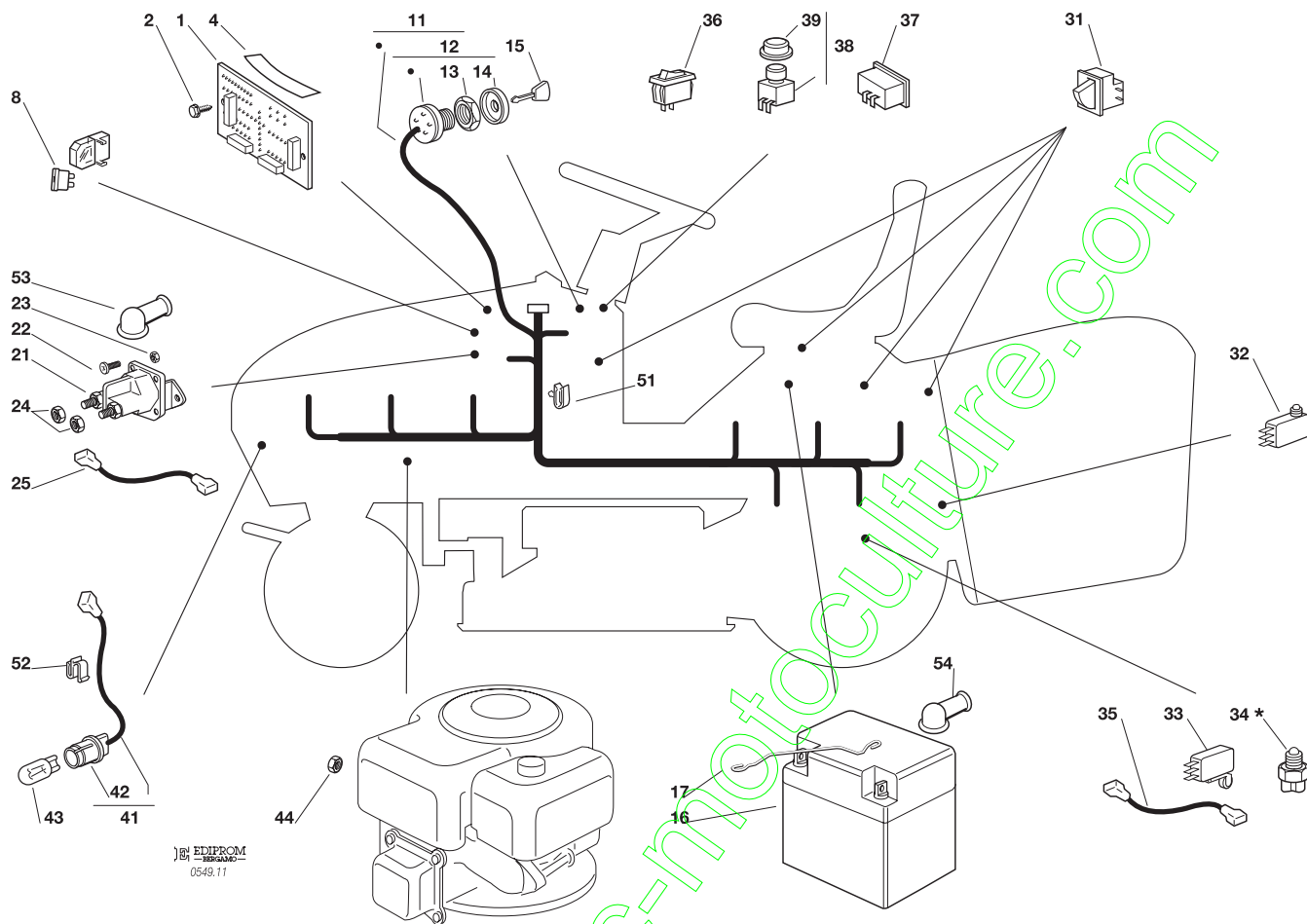

EDIPROM  
 0549.11

N.	CODE	Q.TY	DESCRIZIONE	DESCRIPTION	DESCRIPTION	BESCHREIBUNG
2	12735105/0	3	VITE	SCREW	VIS	SCHRAUBE
4	25420004/0	1	MEMBRANA (12360)	CHECK CONTROL (12360)	PANNEAU DE CONTROLE (12360)	KONTROLLTAFEL (12360)
	25420005/0	1	MEMBRANA (4)	CHECK CONTROL (4)	PANNEAU DE CONTROLE (4)	KONTROLLTAFEL (4)
	25420007/0	1	MEMBRANA (60)	CHECK CONTROL (60)	PANNEAU DE CONTROLE (60)	KONTROLLTAFEL (60)
8	33340040/0	1	FUSIBILE 10 A	FUSE 10 A	FUSIBLE 10 A	SICHERUNG 10 A
	33340036/0	1	FUSIBILE 25 A	FUSE 25 A	FUSIBLE 25 A	SICHERUNG 25 A
11	82040137/0	1	CABLAGGIO	CABLES ASS.Y	ENS. CABLAGES	KABELSATZ
12	18450065/1	1	INTERRUTTORE AVVIAM.	STARTING SWITCH	INTERRUPTEUR DEMARR.	SCHALTER
13	18400861/0	1	GHIERA	RINGNUT	EMBOUT	NUTMUTTER
14	18565351/0	1	PROTEZIONE GHIERA	RINGNUT PROTECTION	PROTECTION EMBOUT	NUTMUTTER SCHUTZ
15	18210016/1	1	CHIAVE AVVIAMENTO	STARTING KEY	CLEF A DEMARRAGE	SCHLÜSSEL FÜR START
16	18120002/1	1	BATTERIA	BATTERY	BATTERIE	BATTERIE
17	25430230/0	1	MOLLA	SPRING	RESSORT	FEDER
21	18736110/0	1	RELE AVVIAM. (1234560)	STARTER RELAY (1234560)	RELAIS D'ALL. (1234560)	ANLASSRELAIS (1234560)
22	12791011/0	2	VITE (1234560)	SCREW (1234560)	VIS (1234560)	SCHRAUBE (1234560)
23	12292102/0	2	DADO (1234560)	NUT (1234560)	ECROU (1234560)	MUTTER (1234560)
24	12360352/0	2	DADO (1234560)	NUT (1234560)	ECROU (1234560)	MUTTER (1234560)
25	25065017/0	1	CAVO RELÉ AVV. (1234560)	CABLE (1234560)	CABLE (1234560)	KABEL (1234560)
32	19410605/1	1	MICRO SACCO PIENO	FULL GRASSCAT. MICROSW.	MICRO BAC PLEIN	VOLLKORB VORRICHTUNG
33	19410609/0	1	MICRO FOLLE (hydro)	NEUTRAL SWITCH (hydro)	MICRO. POINT MORT (hydro)	LEERLAUF MIKROSCH. (hydro)
34*	-	1	MICRO FOLLE (mecc.)	NEUTRAL SWITCH (mech.)	MICRO. POINT MORT (mech.)	LEERLAUF MIKROSCH. (mech.)
35	25065026/0	1	CABL. MICRO FOLLE (mecc.)	CABLE (mech.)	CABLES (mech.)	KABEL (mech.)
36	18450060/1	1	INTERRUTTORE	FARILAMP SWITCH	INTERRUPTEUR PHARES	LICHTEN SCHALTER
37	18230000/0	1	CONTORE	HOUR COUNTER	COMPTE-HEURS	BETRIEBSSTUNDEZÄHLER



N.	CODE	Q.TY	DESCRIZIONE	DESCRIPTION	DESCRIPTION	BESCHREIBUNG
41	82040070/0	1	CABLAGGIO LAMPADE	CABLE	CABLES	KABEL
	82040073/0	1	CABLAGGIO LAMPADE (TCX)	CABLE (TCX)	CABLES (TCX)	KABEL (TCX)
42	33500030/0	2	PORTALAMPADE	LAMP HOLDER	DOUILLE DE LAMPE	SCHEINWERFERLAMPE
43	18459100/0	2	LAMPADA	FARILAMP FOR LIGHTS	LAMPE POUR PHARES	LAMPENFASSUN
44	12361005/0	1	DADO	NUT	ECROU	MUTTER
51	33320506/0	5	FERMACAVO	FAIRLED	FIXATION CABLE	KABELBEFESTIGUNG
52	33320504/0	1	FERMACAVO	FAIRLED	FIXATION CABLE	KABELBEFESTIGUNG
53	18564861/1	1	CAPPUCCIO (12224555)	PROTECTION (12224555)	CAPUCHON (12224555)	STECKER (12224555)
54	18564864/1	1	CAPPUCCIO	PROTECTION	CAPUCHON	STECKER
			<b>Nei modelli con innesto delle lame a leva:</b>	<b>For models with engagement of the blades by lever:</b>	<b>Dans les modèles avec embrayage des lames à levier:</b>	<b>Bei Modellen mit Hebelschaltung der Messer:</b>
1	25722412/1	1	SCHEDA ELETTRONICA	ELECTRONIC CARD	CARTE ELECTRONIQUE	ELEKTRONISCHE KARTE
31	19410606/0	4	MICRO INTERRUPTORE	MICRO	MICRO	MIKRO
			<b>Nei modelli con innesto delle lame elettromagnetico:</b>	<b>For models with engagement of the blades by electromagnetic clutch:</b>	<b>Dans les modèles avec embrayage des lames électromagnétique:</b>	<b>Bei Modellen mit elektromagnetischer Schaltung der Messer:</b>
1	25722413/1	1	SCHEDA ELETTRONICA	ELECTRONIC CARD	CARTE ELECTRONIQUE	ELEKTRONISCHE KARTE
31	19410606/0	3	MICRO INTERRUPTORE	MICRO	MICRO	MIKRO
38	18450067/0	1	INTERRUPTORE FRIZIONE	CLUTCH SWITCH	INTERRUPTEUR EMBRAJAGE	KUPPLUNG SCHALTER
39	18203852/0	1	CAPPUCCIO	PROTECTION	CAPUCHON	STECKER

PER LA SOSTITUZIONE DELLE PARTI CONTRASSEGNAE CON «\*» RIVOLGERSI AL SERVIZIO ASSISTENZA DEL COSTRUTTORE DELLA TRASMISSIONE.  
 TO REPLACE THE PARTS MARKED «\*» SEEK ASSISTANCE FROM THE TRANSMISSION MANUFACTURER'S AFTER SALES SERVICE.  
 POUR LE REMPLACEMENT DES PIÈCES MARQUÉES AVEC «\*» S'ADRESSER AU SERVICE APRÈS VENTES DU CONSTRUCTEUR DE LA TRANSMISSION.  
 ZUM AUSTAUSCH DER MIT «\*» GEKENNZEICHNETEN TEILE, WENDEN SIE SICH AN DEN KUNDENDIENST DES HERSTELLERS DES ANTRIEBS.

Per motore / For engine / Pour moteur / Für Motor: (1) B&S 12 - 12,5 HP (2) B&S 15 - 15,5 HP (3) B&S 17,5 HP (4) B&S 18 - 20 - 22 HP  
 (5) TECUMSEH 13,5 - 14,5 - 15 - 16 HP (6) TECUMSEH 20 HP (7) HONDA GCV 530 (8) HONDA GXV 610 (9) KOHLER 16 - 18 HP (10) KOHLER 20 - 22 HP

contact@emc-photochimie.com

TC	TCP	TCR	TCB	TCX	TX
102	102 hydro	102 hydro	102 hydro	122 hydro	122 hydro

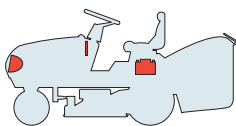

PARTI ELETTRICHE  
ELECTRICAL PARTS  
PARTIES ELECTRIQUES  
ELETRISCHETEILE  
HONDA

2006
011a.0
1 / 2

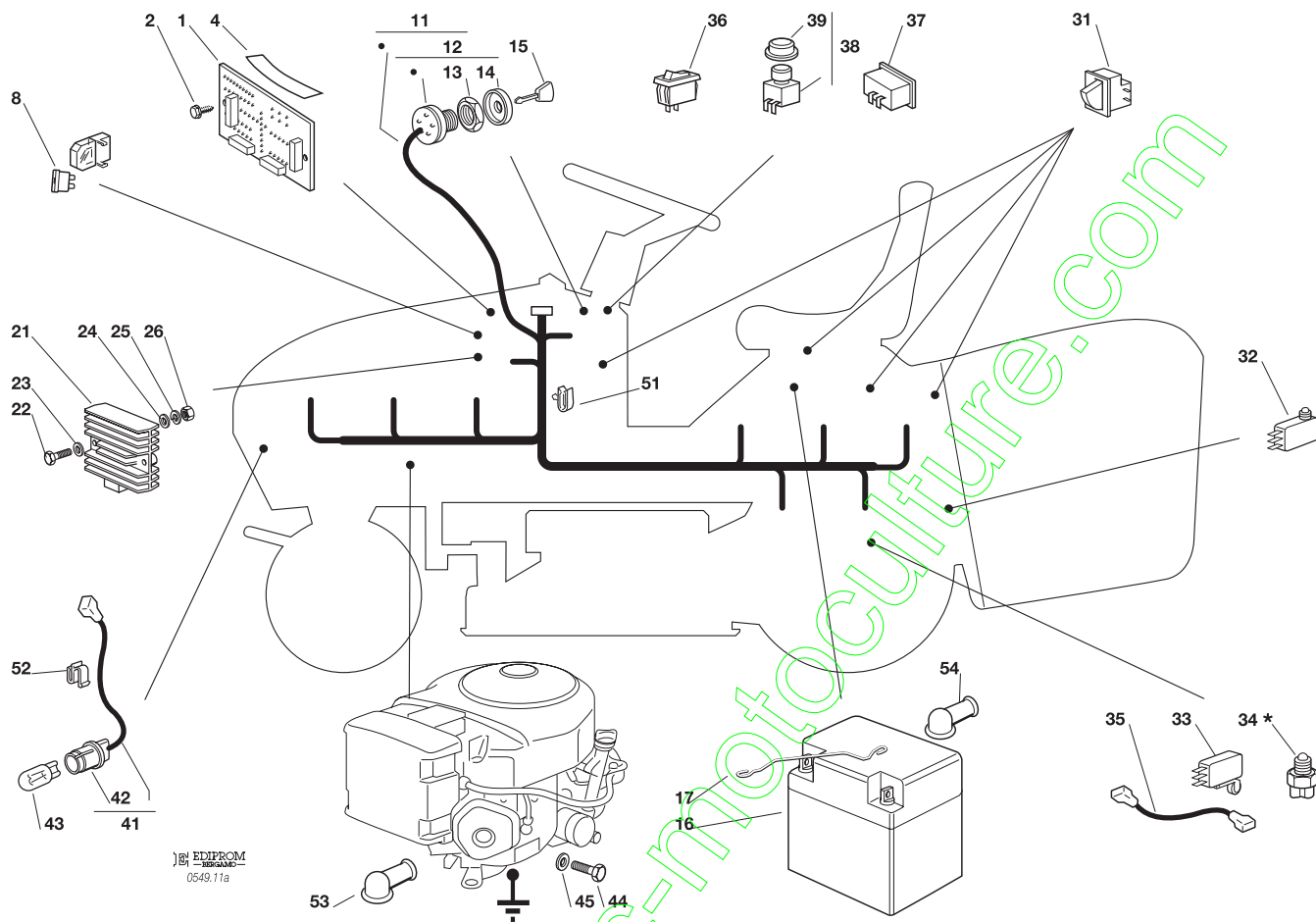

EDIPROM  
0549.11a

N.	CODE	Q.TY	DESCRIZIONE	DESCRIPTION	DESCRIPTION	BESCHREIBUNG
2	12735105/0	3	VITE	SCREW	VIS	SCHRAUBE
4	25420007/0	1	MEMBRANA (GCV 530)	CHECK CONTROL (GCV 530)	PANNEAU DE CON. (GCV 530)	KONTROLLTAFEL (GCV 530)
	25420005/0	1	MEMBRANA (GXV 610)	CHECK CONTROL (GXV 610)	PANNEAU DE CON. (GXV 610)	KONTROLLTAFEL (GXV 610)
8	33340040/0	1	FUSIBILE 10 A	FUSE 10 A	FUSIBLE 10 A	SICHERUNG 10 A
	33340036/0	1	FUSIBILE 25 A	FUSE 25 A	FUSIBLE 25 A	SICHERUNG 25 A
11	82040140/0	1	CABLAGGIO	CABLES ASS.Y	ENS. CABLAGES	KABELSATZ
12	18450065/1	1	INTERRUTTORE AVVIAM.	STARTING SWITCH	INTERRUPTEUR DEMARR.	SCHALTER
13	18400861/0	1	GHIERA	RINGNUT	EMBOUT	NUTMUTTER
14	18565351/0	1	PROTEZIONE GHIERA	RINGNUT PROTECTION	PROTECTION EMBOUT	NUTMUTTER SCHUTZ
15	18210016/1	1	CHIAVE AVVIAMENTO	STARTING KEY	CLEF A DEMARRAGE	SCHLÜSSEL FÜR START
16	18120002/1	1	BATTERIA	BATTERY	BATTERIE	BATTERIE
17	25430230/0	1	MOLLA	SPRING	RESSORT	FEDER
21◆	-	1	RELÉ AVVIAMENTO	STARTER RELAY	RELAIS D'ALLUMAGE	ANLASSRELAIS
22	12791599/0	2	VITE	SCREW	VIS	SCHRAUBE
23	12521330/0	2	RONDELLA	WASHER	RONDELLE	SCHEIBE
24	12521330/0	2	RONDELLA	WASHER	RONDELLE	SCHEIBE
25	12582100/0	2	GROWER	GROWER	GROWER	GROWER
26	12292100/0	2	DADO	NUT	ECROU	MUTTER
32	19410605/1	1	MICRO SACCO PIENO	FULL GRASSCAT. MICROSW.	MICRO BAC PLEIN	VOLLKORB VORRICHTUNG
33	19410609/0	1	MICRO FOLLE (hydro)	NEUTRAL SWITCH (hydro)	MICRO. POINT MORT (hydro)	LEERLAUF MIKROSCH. (hydro)
34*	-	1	MICRO FOLLE (mecc.)	NEUTRAL SWITCH (mecc.)	MICRO. POINT MORT (mecc.)	LEERLAUF MIKROSCH. (mecc.)
35	25065026/0	1	CABL. MICRO FOLLE (mecc.)	CABLE (mecc.)	CABLES (mecc.)	KABEL (mecc.)
36	18450060/1	1	INTERRUTTORE	FARILAMP SWITCH	INTERRUPTEUR PHARES	LICHTEN SCHALTER
37	18230000/0	1	CONTAORE	HOUR COUNTER	COMPTE-HEURS	BETRIEBSSTUNDEZÄHLER





N.	CODE	Q.TY	DESCRIZIONE	DESCRIPTION	DESCRIPTION	BESCHREIBUNG
41	82040070/0	1	CABLAGGIO LAMPADE	CABLE	CABLES	KABEL
	82040073/0	1	CABLAGGIO LAMPADE (TCX)	CABLE (TCX)	CABLES (TCX)	KABEL (TCX)
42	33500030/0	2	PORTALAMPADE	LAMP HOLDER	DOUILLE DE LAMPE	SCHEINWERFERLAMPE
43	18459100/0	2	LAMPADA	FARILAMP FOR LIGHTS	LAMPE POUR PHARES	LAMPENFASSUN
44	12791599/0	2	VITE	SCREW	VIS	SCHRAUBE
45	12521330/0	2	RONDELLA	WASHER	RONDELLE	SCHNEIBE
51	33320506/0	5	FERMACAVO	FAIRLED	FIXATION CABLE	KABELBEFESTIGUNG
52	33320504/0	1	FERMACAVO	FAIRLED	FIXATION CABLE	KABELBEFESTIGUNG
53	18564861/1	1	CAPPUCCIO	PROTECTION	CAPUCHON	STECKER
54	18564864/1	1	CAPPUCCIO	PROTECTION	CAPUCHON	STECKER
			<b>Nei modelli con innesto delle lame a leva:</b>	<b>For models with engagement of the blades by lever:</b>	<b>Dans les modèles avec embrayage des lames à levier:</b>	<b>Bei Modellen mit Hebelschaltung der Messer:</b>
1	25722412/1	1	SCHEDA ELETTRONICA	ELECTRONIC CARD	CARTE ELECTRONIQUE	ELEKTRONISCHE KARTE
31	19410606/0	4	MICRO INTERRUTTORE	MICRO	MICRO	MIKRO
			<b>Nei modelli con innesto delle lame elettromagnetico:</b>	<b>For models with engagement of the blades by electromagnetic clutch:</b>	<b>Dans les modèles avec embrayage des lames électromagnétique:</b>	<b>Bei Modellen mit elektromagnetischer Schaltung der Messer:</b>
1	25722413/1	1	SCHEDA ELETTRONICA	ELECTRONIC CARD	CARTE ELECTRONIQUE	ELEKTRONISCHE KARTE
31	19410606/0	3	MICRO INTERRUTTORE	MICRO	MICRO	MIKRO
38	18450067/0	1	INTERRUTTORE FRIZIONE	CLUTCH SWITCH	INTERRUPTEUR EMBRAJAGE	KUPPLUNG SCHALTER
39	18203852/0	1	CAPPUCCIO	PROTECTION	CAPUCHON	STECKER

PER LA SOSTITUZIONE DELLE PARTI CONTRASSEGNALE CON «\*» RIVOLGERSI AL SERVIZIO ASSISTENZA DEL COSTRUTTORE DELLA TRASMISSIONE.  
 TO REPLACE THE PARTS MARKED «\*» SEEK ASSISTANCE FROM THE TRANSMISSION MANUFACTURER'S AFTER SALES SERVICE.  
 POUR LE REMPLACEMENT DES PIÈCES MARQUÉES AVEC «\*» S'ADRESSER AU SERVICE APRÈS VENTES DU CONSTRUCTEUR DE LA TRANSMISSION.  
 ZUM AUSTAUSCH DER MIT «\*» GEKENNZEICHNETEN TEILE, WENDEN SIE SICH AN DEN KUNDENDIENST DES HERSTELLERS DES ANTRIEBS.

PER LA SOSTITUZIONE DELLE PARTI CONTRASSEGNALE CON «◆» RIVOLGERSI AL SERVIZIO ASSISTENZA DEL COSTRUTTORE DEL MOTORE.  
 TO REPLACE THE PARTS MARKED «◆» SEEK ASSISTANCE FROM THE ENGINE MANUFACTURER'S AFTER SALES SERVICE.  
 POUR LE REMPLACEMENT DES PIÈCES MARQUÉES AVEC «◆» S'ADRESSER AU SERVICE APRÈS VENTES DU CONSTRUCTEUR DU MOTEUR.  
 ZUM AUSTAUSCH DER MIT «◆» GEKENNZEICHNETEN TEILE, WENDEN SIE SICH AN DEN KUNDENDIENST DES HERSTELLERS DES MOTOR.

contact@ers-photostructure.com

TC	TCP	TCR	TCB	TCX	TX
102	102 hydro	122 hydro			

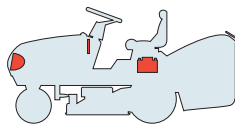

**PARTI ELETTRICHE**  
**ELECTRICAL PARTS**  
**PARTIES ELECTRIQUES**  
**ELETRISCHE TEILE**  
**B&S - TECUMSEH - KOHLER**

2006
<b>011b.0</b>
1 / 2

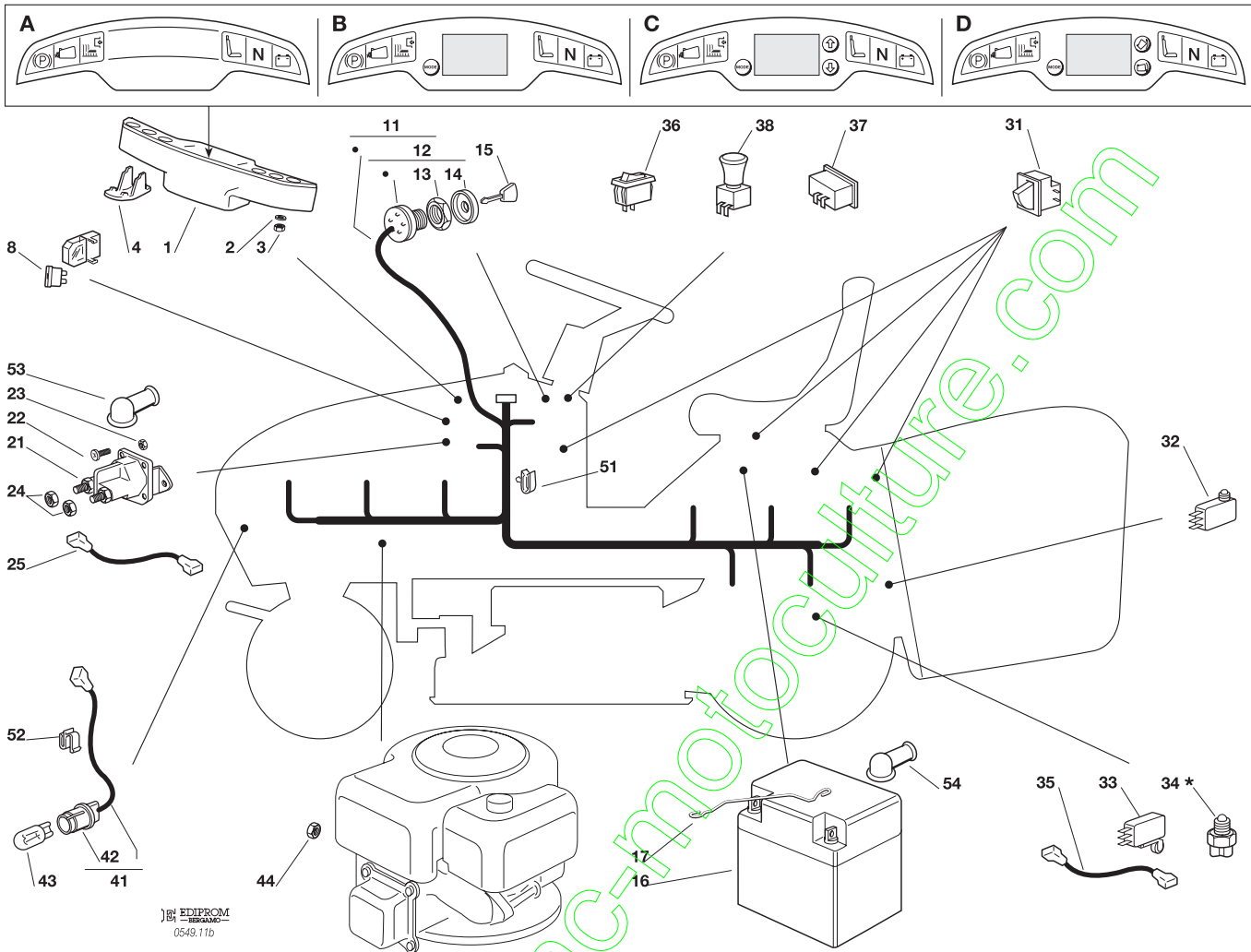

N.	CODE	Q.TY	DESCRIZIONE	DESCRIPTION	DESCRIPTION	BESCHREIBUNG
1	82722420/0	1	SCHEDE + PROTEZIONI (A)	CARDS + GUARDS (A)	CARTES + PROTECTIONS (A)	KARTE + SCHUTZE (A)
	82722421/0	1	SCHEDE + PROTEZIONI (B)	CARDS + GUARDS (B)	CARTES + PROTECTIONS (B)	KARTE + SCHUTZE (B)
	82722423/0	1	SCHEDE + PROTEZIONI (C)	CARDS + GUARDS (C)	CARTES + PROTECTIONS (C)	KARTE + SCHUTZE (C)
	82722422/0	1	SCHEDE + PROTEZIONI (D)	CARDS + GUARDS (D)	CARTES + PROTECTIONS (D)	KARTE + SCHUTZE (D)
2	12521320/0	2	RONDELLA	WASHER	RONDELLE	SCHEIBE
3	12154330/0	2	DADO	NUT	ECROU	MUTTER
4	25031501/0	1	DEFLETTORE BUZZER	DEFLECTOR	DEFLECTEUR	ABWEISER
11	82040135/0	1	CABLAGGIO	CABLES ASS.Y	ENS. CABLAGES	KABELSATZ
12	18450065/1	1	INTERRUTTORE AVVIAM.	STARTING SWITCH	INTERRUPTEUR DEMARR.	SCHALTER
13	18400861/0	1	GHIERA	RINGNUT	EMBOUT	NUTMUTTER
14	18565351/0	1	PROTEZIONE GHIERA	RINGNUT PROTECTION	PROTECTION EMBOUT	NUTMUTTER SCHUTZ
15	18210016/1	1	CHIAVE AVVIAMENTO	STARTING KEY	CLEF A DEMARRAGE	SCHLÜSSEL FÜR START
16	18120002/1	1	BATTERIA	BATTERY	BATTERIE	BATTERIE
17	25430230/0	1	MOLLA	SPRING	RESSORT	FEDER
21	18736110/0	1	RELÉ AVVIAM. (1234569)	STARTER RELAY (1234569)	RELAIS D'ALL. (1234569)	ANLASSRELAIS (1234569)
22	12791011/0	2	VITE (1234569)	SCREW (1234569)	VIS (1234569)	SCHRAUBE (1234569)
23	12292102/0	2	DADO (1234569)	NUT (1234569)	ECROU (1234569)	MUTTER (1234569)
24	12360352/0	2	DADO (1234569)	NUT (1234569)	ECROU (1234569)	MUTTER (1234569)
25	25065002/0	1	CAVO RELÉ AVV. (1234569)	CABLE (1234569)	CABLE (1234569)	KABEL (1234569)
32	19410605/1	1	MICRO SACCO PIENO	FULL GRASSCAT. MICROSW.	MICRO BAC PLEIN	VOLLKORB VORRICHTUNG
33	19410609/0	1	MICRO FOLLE (hydro)	NEUTRAL SWITCH (hydro)	MICRO. POINT MORT (hydro)	LEERLAUF MIKROSCH. (hydro)
34*	-	1	MICRO FOLLE (mecc.)	NEUTRAL SWITCH (mech.)	MICRO. POINT MORT (mec.)	LEERLAUF MIKROSCH. (mech.)
35	25065026/0	1	CABL. MICRO FOLLE (mecc.)	CABLE (mech.)	CABLES (mec.)	KABEL (mech.)
36	18450060/1	1	INTERRUTTORE	FARILAMP SWITCH	INTERRUPTEUR PHARES	LICHTEN SCHALTER
37	18230000/0	1	CONTAORE	HOUR COUNTER	COMPTE-HEURS	BETRIEBSSTUNDEZÄHLER





N.	CODE	Q.TY	DESCRIZIONE	DESCRIPTION	DESCRIPTION	BESCHREIBUNG
41	82040073/0	1	CABLAGGIO LAMPADE	CABLE	CABLES	KABEL
42	33500030/0	2	PORTALAMPADE	LAMP HOLDER	DOUILLE DE LAMPE	SCHEINWERFERLAMPE
43	18459100/0	2	LAMPADA	FARILAMP FOR LIGHTS	LAMPE POUR PHARES	LAMPENFASSUN
44	12361005/0	1	DADO	NUT	ECROU	MUTTER
51	33320506/0	5	FERMACAVO	FAIRLED	FIXATION CABLE	KABELBEFESTIGUNG
52	33320504/0	1	FERMACAVO	FAIRLED	FIXATION CABLE	KABELBEFESTIGUNG
53	18564861/1	1	CAPPUCCIO (1234569)	PROTECTION (1234569)	CAPUCHON (1234569)	STECKER (1234569)
54	18564864/1	1	CAPPUCCIO	PROTECTION	CAPUCHON	STECKER
			<b>Nei modelli con innesto delle lame a leva:</b>	<b>For models with engagement of the blades by lever:</b>	<b>Dans les modèles avec embrayage des lames à levier:</b>	<b>Bei Modellen mit Hebelschaltung der Messer:</b>
31	19410606/0	4	MICRO INTERRUOTTORE	MICRO	MICRO	MIKRO
			<b>Nei modelli con innesto delle lame elettromagnetico:</b>	<b>For models with engagement of the blades by electromagnetic clutch:</b>	<b>Dans les modèles avec embrayage des lames électromagnétique:</b>	<b>Bei Modellen mit elektromagnetischer Schaltung der Messer:</b>
31	19410606/0	3	MICRO INTERRUOTTORE	MICRO	MICRO	MIKRO
38	18450068/0	1	INTERRUPTORE FRIZIONE	CLUTCH SWITCH	INTERRUPTEUR EMBRAJAGE	KUPPLUNG SCHALTER
			<b>Modelli con sollevamento manuale:</b>	<b>Models with manual tipping:</b>	<b>Modèles avec renversement manuelle:</b>	<b>Modellen mit Handbedienung:</b>
8	33340040/0	1	FUSIBILE 10 A	FUSE 10 A	FUSIBLE 10 A	SICHERUNG 10 A
	33340036/0	1	FUSIBILE 25 A	FUSE 25 A	FUSIBLE 25 A	SICHERUNG 25 A
			<b>Modelli con sollevamento elettrico:</b>	<b>Models with electric tipping:</b>	<b>Modèles avec renversement électrique:</b>	<b>Modellen mit elektrischer Bedienung:</b>
8	33340040/0	2	FUSIBILE 10 A	FUSE 10 A	FUSIBLE 10 A	SICHERUNG 10 A
	33340036/0	1	FUSIBILE 25 A	FUSE 25 A	FUSIBLE 25 A	SICHERUNG 25 A

PER LA SOSTITUZIONE DELLE PARTI CONTRASSEGNAE CON «\*» RIVOLGERSI AL SERVIZIO ASSISTENZA DEL COSTRUTTORE DELLA TRASMISSIONE.  
 TO REPLACE THE PARTS MARKED «\*» SEEK ASSISTANCE FROM THE TRANSMISSION MANUFACTURER'S AFTER SALES SERVICE.  
 POUR LE REMPLACEMENT DES PIÈCES MARQUÉES AVEC «\*» S'ADRESSER AU SERVICE APRÈS VENTES DU CONSTRUCTEUR DE LA TRANSMISSION.  
 ZUM AUSTAUSCH DER MIT «\*» GEKENNZEICHNETEN TEILE, WENDEN SIE SICH AN DEN KUNDENDIENST DES HERSTELLERS DES ANTRIEBS.

Per motore / For engine / Pour moteur / Für Motor: (1) B&S 12 - 12,5 HP (2) B&S 15 - 15,5 HP (3) B&S 17,5 HP (4) B&S 18 - 20 - 22 HP  
 (5) TECUMSEH 13,5 - 14,5 - 15 - 16 HP (6) TECUMSEH 20 HP (7) HONDA GCV 530 (8) HONDA GXV 610 (9) KOHLER 16 - 18 HP (10) KOHLER 20 - 22 HP

TC	TCP	TCR	TCB	TCX	TX
102	102 hydro	122 hydro			

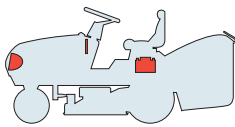

**PARTI ELETTRICHE**  
**ELECTRICAL PARTS**  
**PARTIES ELECTRIQUES**  
**ELETRISCHETEILE**  
**HONDA**

2006
<b>011c.0</b>
1 / 1

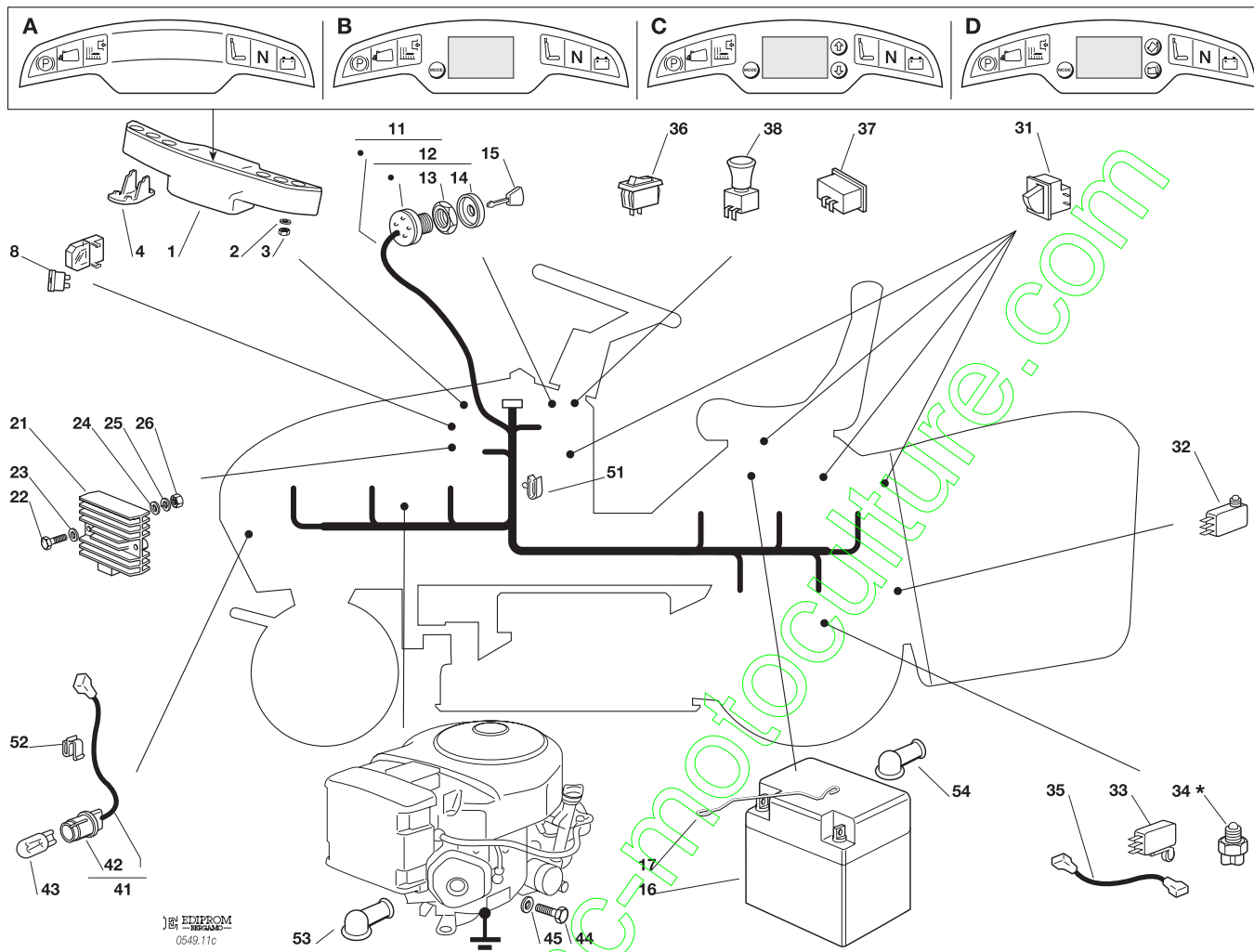

N.	CODE	Q.TY	DESCRIZIONE	DESCRIPTION	DESCRIPTION	BESCHREIBUNG
1	82722420/0	1	SCHEDE + PROTEZIONI (A)	CARDS + GUARDS (A)	CARTES + PROTECTIONS (A)	KARTE + SCHUTZE (A)
	82722421/0	1	SCHEDE + PROTEZIONI (B)	CARDS + GUARDS (B)	CARTES + PROTECTIONS (B)	KARTE + SCHUTZE (B)
	82722423/0	1	SCHEDE + PROTEZIONI (C)	CARDS + GUARDS (C)	CARTES + PROTECTIONS (C)	KARTE + SCHUTZE (C)
	82722422/0	1	SCHEDE + PROTEZIONI (D)	CARDS + GUARDS (D)	CARTES + PROTECTIONS (D)	KARTE + SCHUTZE (D)
2	12521320/0	2	RONDELLA	WASHER	RONDELLE	SCHEIBE
3	12154330/0	2	DADO	NUT	ECROU	MUTTER
4	25031501/0	1	DEFLETTORE BUZZER	DEFLECTOR	DEFLECTEUR	ABWEISER
11	82040134/0	1	CABLAGGIO	CABLES ASS.Y	ENS. CABLAGES	KABELSATZ
12	18450065/1	1	INTERRUTTORE AVVIAM.	STARTING SWITCH	INTERRUPTEUR DEMARR.	SCHALTER
13	18400861/0	1	GHIERA	RINGNUT	EMBOUT	NUTMUTTER
14	18565351/0	1	PROTEZIONE GHIERA	RINGNUT PROTECTION	PROTECTION EMBOUT	NUTMUTTER SCHUTZ
15	18210016/1	1	CHIAVE AVVIAMENTO	STARTING KEY	CLEF A DEMARRAGE	SCHLÜSSEL FÜR START
16	18120002/1	1	BATTERIA	BATTERY	BATTERIE	BATTERIE
17	25430230/0	1	MOLLA	SPRING	RESSORT	FEDER
21◆	-	1	RELE AVVIAMENTO	STARTER RELAY	RELAIS D'ALLUMAGE	ANLASSRELAIS
22	12791599/0	2	VITE	SCREW	VIS	SCHRAUBE
23	12521330/0	2	RONDELLA	WASHER	RONDELLE	SCHEIBE
24	12521330/0	2	RONDELLA	WASHER	RONDELLE	SCHEIBE
25	12582100/0	2	GROWER	GROWER	GROWER	GROWER
26	12292100/0	2	DADO	NUT	ECROU	MUTTER
32	19410605/1	1	MICRO SACCO PIENO	FULL GRASSCAT. MICROSW.	MICRO BAC PLEIN	VOLLKORB VORRICHTUNG
33	19410609/0	1	MICRO FOLLE (hydro)	NEUTRAL SWITCH (hydro)	MICRO. POINT MORT (hydro)	LEERLAUF MIKROSCH. (hydro)
34*	-	1	MICRO FOLLE (mecc.)	NEUTRAL SWITCH (mech.)	MICRO. POINT MORT (mec.)	LEERLAUF MIKROSCH. (mech.)
35	25065026/0	1	CABL. MICRO FOLLE (mecc.)	CABLE (mech.)	CABLES (mec.)	KABEL (mech.)
36	18450060/1	1	INTERRUTTORE	FARILAMP SWITCH	INTERRUPTEUR PHARES	LICHTEN SCHALTER







N.	CODE	Q.TY	DESCRIZIONE	DESCRIPTION	DESCRIPTION	BESCHREIBUNG
37	18230000/0	1	CONTAORE	HOUR COUNTER	COMPTE-HEURS	BETRIEBSSTUNDEZÄHLER
41	82040073/0	1	CABLAGGIO LAMPADE	CABLE	CABLES	KABEL
42	33500030/0	2	PORTALAMPADE	LAMP HOLDER	DOUILLE DE LAMPE	SCHEINWERFERLAMPE
43	18459100/0	2	LAMPADA	FARILAMP FOR LIGHTS	LAMPE POUR PHARES	LAMPENFASSUN
44	12791599/0	2	VITE	SCREW	VIS	SCHRAUBE
45	12521330/0	2	RONDELLA	WASHER	RONDELLE	SCHLEIBE
51	33320506/0	5	FERMACAVO	FAIRLED	FIXATION CABLE	KABELBEFESTIGUNG
52	33320504/0	1	FERMACAVO	FAIRLED	FIXATION CABLE	KABELBEFESTIGUNG
53	18564861/1	1	CAPPUCCIO	PROTECTION	CAPUCHON	STECKER
54	18564864/1	1	CAPPUCCIO	PROTECTION	CAPUCHON	STECKER
			<b>Nei modelli con innesto delle lame a leva:</b>	<b>For models with engagement of the blades by lever:</b>	<b>Dans les modèles avec embrayage des lames à levier:</b>	<b>Bei Modellen mit Hebelschaltung der Messer:</b>
31	19410606/0	4	MICRO INTERRUPTORE	MICRO	MICRO	MIKRO
			<b>Nei modelli con innesto delle lame elettromagnetico:</b>	<b>For models with engagement of the blades by electromagnetic clutch:</b>	<b>Dans les modèles avec embrayage des lames électromagnétique:</b>	<b>Bei Modellen mit elektromagnetischer Schaltung der Messer:</b>
31	19410606/0	3	MICRO INTERRUPTORE	MICRO	MICRO	MIKRO
38	18450068/0	1	INTERRUPTORE FRIZIONE	CLUTCH SWITCH	INTERRUPTEUR EMBRAJAGE	KUPPLUNG SCHALTER
			<b>Modelli con sollevamento manuale:</b>	<b>Models with manual tipping:</b>	<b>Modèles avec renversement manuelle:</b>	<b>Modellen mit Handbedienung:</b>
8	33340040/0	1	FUSIBILE 10 A	FUSE 10 A	FUSIBLE 10 A	SICHERUNG 10 A
	33340036/0	1	FUSIBILE 25 A	FUSE 25 A	FUSIBLE 25 A	SICHERUNG 25 A
			<b>Modelli con sollevamento elettrico:</b>	<b>Models with electric tipping:</b>	<b>Modèles avec renversement électrique:</b>	<b>Modellen mit elektrischer Bedienung:</b>
8	33340040/0	2	FUSIBILE 10 A	FUSE 10 A	FUSIBLE 10 A	SICHERUNG 10 A
	33340036/0	1	FUSIBILE 25 A	FUSE 25 A	FUSIBLE 25 A	SICHERUNG 25 A

PER LA SOSTITUZIONE DELLE PARTI CONTRASSEGNALE CON «\*» RIVOLGERSI AL SERVIZIO ASSISTENZA DEL COSTRUTTORE DELLA TRASMISSIONE.  
 TO REPLACE THE PARTS MARKED «\*» SEEK ASSISTANCE FROM THE TRANSMISSION MANUFACTURER'S AFTER SALES SERVICE.  
 POUR LE REMPLACEMENT DES PIÈCES MARQUÉES AVEC «\*» S'ADRESSER AU SERVICE APRÈS VENTES DU CONSTRUCTEUR DE LA TRANSMISSION.  
 ZUM AUSTAUSCH DER MIT «\*» GEKENNZEICHNETEN TEILE, WENDEN SIE SICH AN DEN KUNDENDIENST DES HERSTELLERS DES ANTRIEBS.

PER LA SOSTITUZIONE DELLE PARTI CONTRASSEGNALE CON «◆» RIVOLGERSI AL SERVIZIO ASSISTENZA DEL COSTRUTTORE DEL MOTORE.  
 TO REPLACE THE PARTS MARKED «◆» SEEK ASSISTANCE FROM THE ENGINE MANUFACTURER'S AFTER SALES SERVICE.  
 POUR LE REMPLACEMENT DES PIÈCES MARQUÉES AVEC «◆» S'ADRESSER AU SERVICE APRÈS VENTES DU CONSTRUCTEUR DU MOTEUR.  
 ZUM AUSTAUSCH DER MIT «◆» GEKENNZEICHNETEN TEILE, WENDEN SIE SICH AN DEN KUNDENDIENST DES HERSTELLERS DES MOTOR.

TC	TCP	TCR	TCB	TCX	TX
102	102 hydro	102 hydro	102 hydro	122 hydro	122 hydro

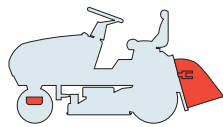

ACCESSORI A RICHIESTA  
 OPTIONALS ON REQUEST  
 ACCESSOIRES SUR DEMANDE  
 ZUBEHOERE NACH ANFRAGE

2006
012.0
1 / 2

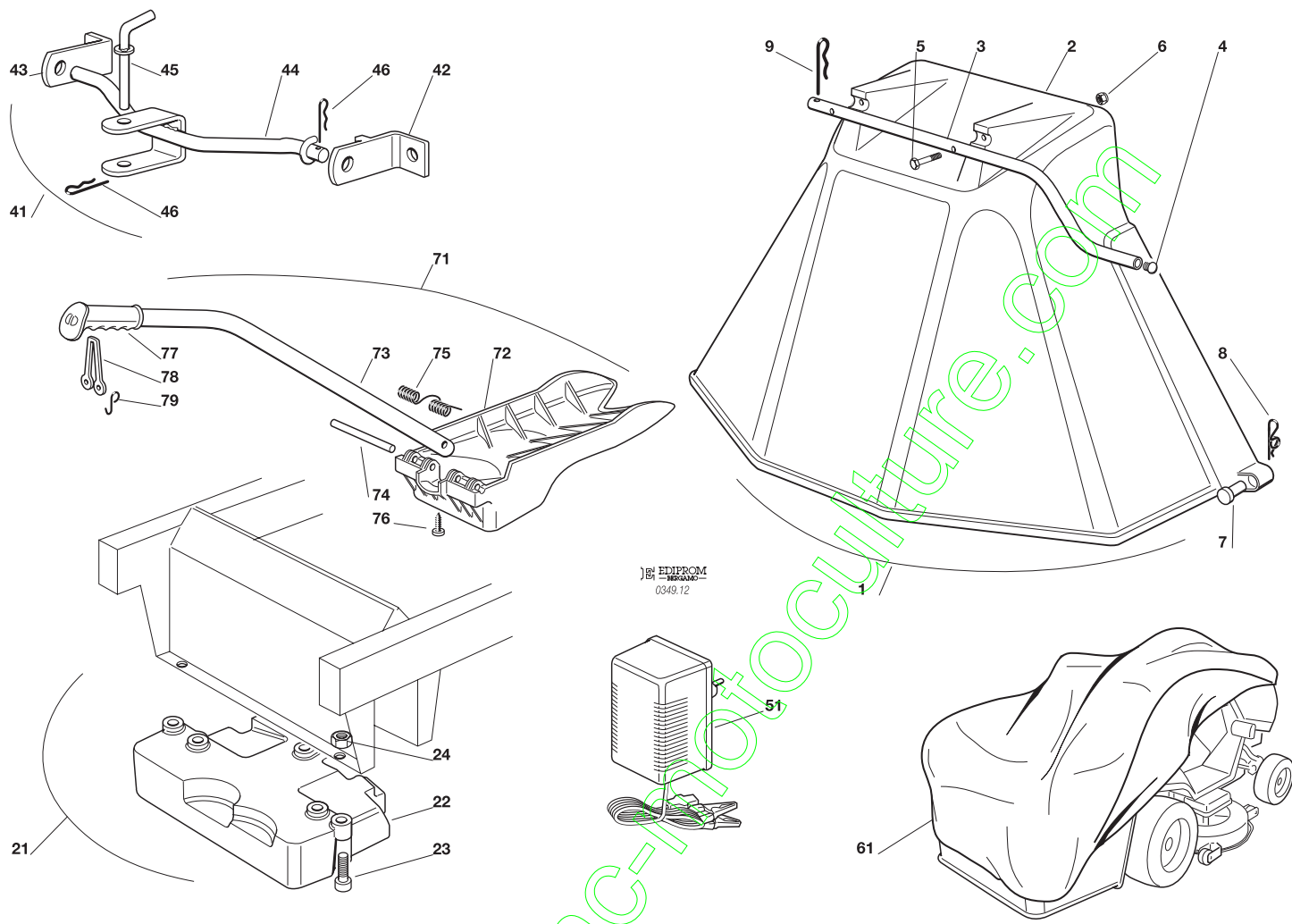

N.	CODE	Q.TY	DESCRIZIONE	DESCRIPTION	DESCRIPTION	BESCHREIBUNG
1	99900015/1	1	ASS. KIT PROTEZIONE USCITA	EJECTION-GUARD ASS.Y	KIT PROTECTION SORTIE	VORRICHTUNG FÜR AUSWURESCHUTZ
2	82400003/1	1	PROTEZIONE USCITA	EJECTION GUARD	PROTECTION SORTIE	AUSWURFSCHUTZ
3	25869043/0	1	TUBO DI AGGANCIAMENTO	SUPPORT	SOPPORT	HALTER
4	18566110/0	2	PUNTALE	CAP	BOUCHON	PFROPFEN
5	12689515/0	2	VITE	SCREW	VIS	SCHRAUBE
6	12154510/0	2	DADO	NUT	ECROU	MUTTER
7	25510022/0	2	PERNO	PIN	PIVOT	BOLZEN
8	24487998/0	2	COPPIGLIA	COTTER PIN	GOUPILLE	SPLIT
9	24487999/0	1	COPPIGLIA	COTTER PIN	GOUPILLE	SPLIT
21	99900030/6	1	ASS. KIT PESO ANT.	FRONT WEIGHT KIT	KIT POIDS ANTERIEUR	VORDERGEWICHT VORRICHTUNG
22	25519997/1	1	PESO	WEIGHT	POIDS	GEWICHT
23	12760520/0	3	VITE	SCREW	VIS	SCHRAUBE
24	12155000/0	3	DADO	NUT	ECROU	MUTTER
41	99900005/0	1	ASS. KIT TRAINO	HITCH KIT	KIT DE TRAINAGE	ZUGVORRICHTUNG
42	82735502/0	1	STAFFA SUPPORTO TRAINO DX	BRACKET RIGHT HITCH SUPPORT	ETRIER SUPPORT TRAINAGE DROITE	BUEGEL HALTER FÜR RECHTEN ZUG
43	25774213/0	1	STAFFA SUPPORTO TRAINO SX	BRACKET LEFT HITCH SUPPORT	ETRIER SUPPORT TRAINAGE GAUCHE	BUEGELHALTER FÜR LINKEN ZUG
44	82033105/0	1	BARRA	ROD	BARRE	STANGE
45	25510021/1	1	PERNO	PIN	PIVOT	BOLZEN
46	24487999/0	2	COPPIGLIA	COTTER PIN	GOUPILLE	SPLIT
51	82180050/0	1	CARICA BATTERIE	BATTERY CHARGER	CHARGEUR DE BATTERIES	BATTERIELADEGERÄT
	82180052/0	1	CARICA BATTERIE (U.K.)	BATTERY CHARGER (U.K.)	CHARGEUR DE BATTERIES (U.K.)	BATTERIELADEGERÄT (U.K.)
61	18737950/0	1	TELO DI COPERTURA	CLOTH	BÂCHE	PLANE





N.	CODE	Q.TY	DESCRIZIONE	DESCRIPTION	DESCRIPTION	BESCHREIBUNG
71	99900045/0	1	KIT MULCHING (mod. 102)	MULCHING KIT (mod. 102)	KIT MULCHING (mod. 102)	MULCHINGVORRICH. (mod. 102)
	99900046/0	1	KIT MULCHING (mod. 122)	MULCHING KIT (mod. 122)	KIT MULCHING (mod. 122)	MULCHINGVORRICH. (mod. 122)
72	25140091/0	1	DEFLETTORE (mod. 102)	DEFLECTOR (mod. 102)	DEFLECTEUR (mod. 102)	ABWEISER (mod. 102)
	25140092/0	1	DEFLETTORE (mod. 122)	DEFLECTOR (mod. 122)	DEFLECTEUR (mod. 122)	ABWEISER (mod. 122)
73	25394005/0	1	MANICO	HANDLE	GUIDON	STIEL
74	25510074/0	1	PERNO	PIN	PIVOT	BOLZEN
75	25430240/0	1	MOLLA	SPRING	RESSORT	FEDER
76	12728680/0	1	VITE	SCREW	VIS	SCHRAUBE
77	25280000/1	1	IMPUGNATURA	HANDGRIP	BRANCHE	GRIF
78	25840011/1	1	TIRANTE IN GOMMA	ELASTIC TIE-ROD	TIRANT ELASTIQUE	ELASTISCHE ZUGSTÄBE
79	25253004/0	2	GANCIO	HOOK	CROCHET	HAKEN

contact@emc-motoculture.com

TC	TCP	TCR	TCB	TCX	TX
----	-----	-----	-----	-----	----

102

102 hydro

122 hydro

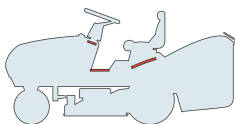

ETICHETTE  
LABELS  
ETIQUETTES  
KLEBZETTEL

2006

013.0

1 / 1



5

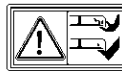

10



14



17

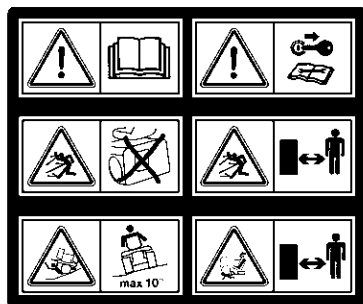

1

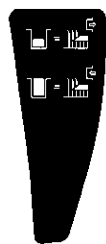

6

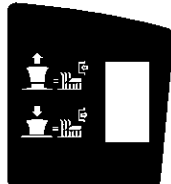

18



13



9



12



8

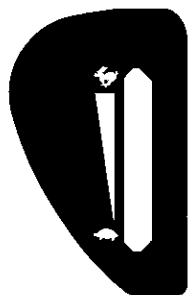

2



11

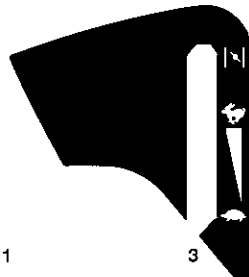

3

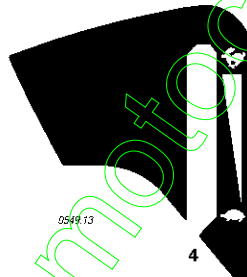

0599.13

4



15

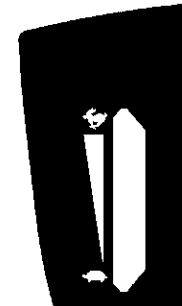

16

N.	CODE	Q.TY	DESCRIZIONE	DESCRIPTION	DESCRIPTION	BESCHREIBUNG
1	14357190/0	1	ETICHETTA	LABEL	ETIQUETTE	KLEBZETTEL
2	14356756/2	1	ETICHETTA	LABEL	ETIQUETTE	KLEBZETTEL
3	14356177/2	1	ETICHETTA	LABEL	ETIQUETTE	KLEBZETTEL
4	14356184/3	1	ETICHETTA	LABEL	ETIQUETTE	KLEBZETTEL
7	14357905/0	1	ETICHETTA	LABEL	ETIQUETTE	KLEBZETTEL
8	14357526/0	1	ETICHETTA	LABEL	ETIQUETTE	KLEBZETTEL
9	14357423/1	1	ETICHETTA (hydro)	LABEL (hydro)	ETIQUETTE (hydro)	KLEBZETTEL (hydro)
10	14356699/0	2	ETICHETTA	LABEL	ETIQUETTE	KLEBZETTEL
11	14356754/1	1	ETICHETTA	LABEL	ETIQUETTE	KLEBZETTEL
12	14357907/0	1	ETICHETTA (mecc.)	LABEL (mech.)	ETIQUETTE (mec.)	KLEBZETTEL (mech.)
13	14357913/0	1	ETICHETTA	LABEL	ETIQUETTE	KLEBZETTEL
14	14360118/0	1	ETICHETTA	LABEL	ETIQUETTE	KLEBZETTEL
15	14360717/0	1	ETICHETTA (TX)	LABEL (TX)	ETIQUETTE (TX)	KLEBZETTEL (TX)
16	14360716/0	1	ETICHETTA (TX)	LABEL (TX)	ETIQUETTE (TX)	KLEBZETTEL (TX)
17	14360719/0	1	ETICHETTA (TX)	LABEL (TX)	ETIQUETTE (TX)	KLEBZETTEL (TX)

Nei modelli con innesto delle lame a leva:

For models with engagement of the blades by lever:

Dans les modèles avec embrayage des lames à levier:

Bei Modellen mit Hebelschaltung der Messer:

5	14357906/0	1	ETICHETTA	LABEL	ETIQUETTE	KLEBZETTEL
---	------------	---	-----------	-------	-----------	------------

Nei modelli con innesto delle lame elettromagnetico:

For models with engagement of the blades by electromagnetic clutch:

Dans les modèles avec embrayage des lames électromagnétique:

Bei Modellen mit elektromagnetischer Schaltung der Messer:

6	14357967/0	1	ETICHETTA	LABEL	ETIQUETTE	KLEBZETTEL
18	14360715/2	1	ETICHETTA (TX)	LABEL (TX)	ETIQUETTE (TX)	KLEBZETTEL (TX)

ELENCO NUMERICO  
NUMERICAL LIST  
LISTE NUMERIQUE  
NUMERISCHE AUFSTELLUNG

contact@enc-mol@culture.com



TC	TCP	TCR	TCB	TCX	TX
----	-----	-----	-----	-----	----

102

102 hydro

122 hydro

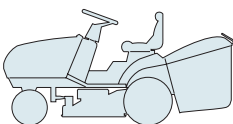

ELENCO NUMERICO  
NUMERICAL LIST  
LISTE NUMERIQUE  
NUMERISCHE AUFSTELLUNG

2006

999.0

1 / 7

CODE	TABLE	N.	Q.TY	CODE	TABLE	N.	Q.TY	CODE	TABLE	N.	Q.TY
12000955/0	010a.0	77	2	12155000/0	012.0	24	3	12360425/0	005b.0	34	2
12000955/0	010a.0	89	2	12155010/0	001.0	84	2	12360425/0	005c.0	34	2
12000956/0	010a.0	85	2	12155010/0	004M.0	62	1	12360425/0	005d.0	34	2
12001000/0	003.0	46	1	12155010/0	004M.0	70	1	12360425/0	005e.0	34	2
12001000/0	003.0	67	2	12155010/0	008.0	84	1	12360425/0	005f.0	34	2
12001010/0	006M.0	78	2	12156602/0	003.0	27	1	12360425/0	005g.0	35	2
12001010/0	006Y.0	78	2	12156602/0	003.0	33	1	12360425/0	005h.0	34	2
12139100/0	009.0	19	2	12156602/0	003.0	34	1	12360425/0	005i.0	34	2
12139430/0	006M.0	43	1	12156602/0	003.0	42	2	12360425/0	006M.0	34	2
12139480/0	008.0	22	3	12156602/0	004M.0	26	1	12360425/0	009.0	33	2
12141418/0	003.0	28	1	12156602/0	004Y.0	14	1	12361005/0	011.0	44	1
12154210/0	005.0	9	1	12156602/0	007.0	40	2	12361005/0	011b.0	44	1
12154210/0	005.0	24	3	12156602/0	007.0	42	2	12369500/0	006Y.0	54	1
12154210/0	005a.0	10	1	12156602/0	007.0	58	2	12372550/0	001.0	96	2
12154210/0	005a.0	11	3	12290800/0	002.0	47	1	12379511/0	003.0	37	2
12154210/0	005b.0	10	1	12290800/0	002a.0	47	1	12400030/0	010.0	54	1
12154210/0	005b.0	12	3	12290800/0	002b.0	47	1	12400030/0	010a.0	54	1
12154210/0	005c.0	10	1	12290800/0	002c.0	47	1	12436030/0	003.0	7	1
12154210/0	005c.0	11	3	12290800/0	002d.0	47	1	12436050/0	002.0	4	2
12154210/0	005d.0	14	1	12290800/0	002e.0	47	1	12436050/0	002a.0	4	2
12154210/0	005e.0	9	4	12292100/0	010.0	11	4	12436050/0	002b.0	4	2
12154210/0	005f.0	8	4	12292100/0	011a.0	26	2	12436050/0	007.0	55	4
12154210/0	005g.0	9	4	12292100/0	011c.0	26	2	12436050/0	007.0	55	6
12154210/0	005h.0	5	1	12292102/0	001.0	16	5	12437502/0	001.0	99	2
12154210/0	005j.0	9	1	12292102/0	001.0	19	6	12500030/0	009.0	4	2
12154210/0	006M.0	47	4	12292102/0	001.0	24	4	12500092/0	002.0	26	2
12154210/0	006Y.0	44	4	12292102/0	001.0	26	2	12500092/0	002a.0	26	2
12154210/0	009.0	17	6	12292102/0	008.0	28	3	12500092/0	002b.0	26	2
12154330/0	001.0	92	1	12292102/0	010.0	44	1	12500092/0	002c.0	26	2
12154330/0	001.0	105	2	12292102/0	010a.0	44	1	12500092/0	002d.0	26	2
12154330/0	001.0	108	2	12292102/0	011.0	23	2	12500092/0	002e.0	26	2
12154330/0	008.0	39	2	12292102/0	011b.0	23	2	12521310/0	002.0	44	2
12154330/0	010a.0	81	1	12293200/0	001.0	36	1	12521310/0	002a.0	44	2
12154330/0	011b.0	3	2	12293200/0	004M.0	75	1	12521310/0	002b.0	44	2
12154330/0	011c.0	3	2	12293200/0	004Y.0	52	2	12521310/0	002c.0	44	2
12154510/0	001.0	13	4	12293200/0	004Y.0	57	2	12521310/0	002d.0	44	2
12154510/0	001.0	117	1	12293200/0	006M.0	14	2	12521310/0	002e.0	44	2
12154510/0	004M.0	44	2	12293200/0	006Y.0	14	2	12521320/0	001.0	95	4
12154510/0	004Y.0	24	2	12293200/0	007.0	66	2	12521320/0	011b.0	2	2
12154510/0	004Y.0	55	1	12293200/0	008.0	20	1	12521320/0	011c.0	2	2
12154510/0	004Y.0	59	1	12293201/0	001.0	8	4	12521330/0	001.0	63	4
12154510/0	006M.0	31	4	12293201/0	001.0	38	2	12521330/0	002.0	30	2
12154510/0	008.0	82	1	12293201/0	001.0	64	4	12521330/0	002a.0	35	2
12154510/0	010.0	15	1	12293201/0	001.0	68	1	12521330/0	002b.0	30	2
12154510/0	010a.0	10	10	12293201/0	001.0	74	2	12521330/0	002c.0	30	2
12154510/0	010a.0	15	8	12293201/0	001.0	79	2	12521330/0	002d.0	38	2
12154510/0	010a.0	20	1	12293201/0	002c.0	4	2	12521330/0	002e.0	38	2
12154510/0	010a.0	27	2	12293201/0	002d.0	35	2	12521330/0	010a.0	9	10
12154510/0	010a.0	74	4	12293201/0	002e.0	35	2	12521330/0	010a.0	14	8
12154510/0	012.0	6	2	12293201/0	005g.0	13	1	12521330/0	010a.0	26	2
12155000/0	003.0	45	1	12293201/0	005g.0	16	4	12521330/0	011a.0	23	2
12155000/0	004M.0	7	1	12293201/0	005j.0	14	4	12521330/0	011a.0	24	2
12155000/0	004M.0	12	1	12293201/0	006M.0	50	2	12521330/0	011a.0	45	2
12155000/0	004M.0	28	1	12293201/0	006Y.0	51	1	12521330/0	011c.0	23	2
12155000/0	004M.0	48	1	12293201/0	007.0	19	2	12521330/0	011c.0	24	2
12155000/0	004M.0	68	1	12293201/0	008.0	3	4	12521330/0	011c.0	45	2
12155000/0	004Y.0	12	1	12293201/0	008.0	73	2	12521331/0	002.0	86	6
12155000/0	004Y.0	16	1	12293201/0	009.0	30	4	12521331/0	002a.0	86	6
12155000/0	004Y.0	28	1	12293201/0	010.0	64	6	12521331/0	002b.0	86	6
12155000/0	006M.0	8	1	12293201/0	010a.0	64	6	12521331/0	002c.0	86	6
12155000/0	006M.0	12	1	12293201/0	010a.0	87	4	12521331/0	002d.0	86	6
12155000/0	006M.0	20	2	12295200/0	001.0	4	2	12521340/0	004M.0	76	1
12155000/0	006M.0	27	4	12295200/0	003.0	18	1	12521350/0	004M.0	9	1
12155000/0	006Y.0	8	1	12295200/0	003.0	24	2	12521350/0	004M.0	15	2
12155000/0	006Y.0	12	1	12295200/0	004M.0	24	1	12521350/0	004Y.0	11	1
12155000/0	006Y.0	20	2	12295200/0	004Y.0	9	1	12521350/0	004Y.0	15	1
12155000/0	006Y.0	27	2	12295200/0	007.0	39	4	12521350/0	005g.0	12	2
12155000/0	006Y.0	48	1	12295200/0	007.0	60	2	12521350/0	006Y.0	47	2
12155000/0	006Y.0	56	1	12295800/0	003.0	51	1	12521350/0	007.0	36	4
12155000/0	007.0	37	2	12360352/0	011.0	24	2	12521350/0	007.0	46	2
12155000/0	007.0	44	2	12360352/0	011b.0	24	2	12521350/0	007.0	54	2
12155000/0	007.0	47	2	12360420/0	001.0	21	2	12521350/0	008.0	11	2
12155000/0	008.0	18	4	12360425/0	001.0	111	1	12521350/0	008.0	17	5
12155000/0	008.0	44	1	12360425/0	005.0	17	2	12521360/0	003.0	23	1
12155000/0	008.0	79	1	12360425/0	005a.0	34	2	12521360/0	004M.0	23	3





CODE	TABLE	N.	Q.TY	CODE	TABLE	N.	Q.TY	CODE	TABLE	N.	Q.TY
12521360/0	004M.0	29	1	12583500/0	004M.0	74	1	12692000/0	006M.0	6	1
12521360/0	004Y.0	8	2	12583500/0	005.0	5	2	12692000/0	006Y.0	6	1
12521360/0	004Y.0	53	1	12583500/0	005.0	20	2	12692050/0	004M.0	67	1
12521370/0	003.0	6	1	12583500/0	005a.0	13	2	12692050/0	008.0	78	1
12521390/0	003.0	49	2	12583500/0	005a.0	37	2	12692050/0	009.0	28	4
12521410/0	006M.0	75	0-4	12583500/0	005b.0	16	4	12692395/0	003.0	44	1
12521410/0	007.0	14	1	12583500/0	005b.0	37	2	12694100/0	003.0	48	1
12523020/0	004M.0	50	1	12583500/0	005c.0	13	2	12726388/0	002.0	46	1
12523020/0	004Y.0	32	1	12583500/0	005c.0	37	2	12726388/0	002a.0	46	1
12523040/0	001.0	12	4	12583500/0	005d.0	11	2	12726388/0	002b.0	46	1
12523040/0	004M.0	43	1	12583500/0	005d.0	37	2	12726388/0	002c.0	46	1
12523040/0	004Y.0	23	1	12583500/0	005e.0	15	4	12726388/0	002d.0	46	1
12523040/0	004Y.0	54	1	12583500/0	005e.0	37	2	12726388/0	002e.0	46	1
12523040/0	004Y.0	58	1	12583500/0	005f.0	37	2	12727795/0	010a.0	80	1
12523050/0	001.0	116	1	12583500/0	005g.0	38	2	12728440/0	002.0	17	4
12523060/0	001.0	110	1	12583500/0	005h.0	13	2	12728440/0	002.0	20	2
12523060/0	004M.0	6	1	12583500/0	005h.0	37	2	12728440/0	002a.0	17	4
12523060/0	004M.0	27	1	12583500/0	005j.0	37	2	12728440/0	002b.0	17	4
12523060/0	004M.0	69	1	12583500/0	008.0	12	2	12728440/0	002b.0	20	2
12523060/0	006M.0	11	1	12583500/0	008.0	25	1	12728440/0	002c.0	17	4
12523060/0	006M.0	19	1	12583500/0	008.0	34	1	12728440/0	002c.0	20	2
12523060/0	006M.0	26	4	12583500/0	008.0	47	1	12728440/0	002d.0	17	4
12523060/0	006M.0	33	2	12583500/0	008.0	47	1	12728440/0	002e.0	17	4
12523060/0	006Y.0	11	1	12585100/0	004Y.0	49	1	12728440/0	002e.0	58	2
12523060/0	006Y.0	19	1	12585100/0	001.0	3	2	12728450/0	010.0	58	2
12523060/0	006Y.0	26	2	12587900/0	003.0	50	1	12728450/0	010a.0	58	2
12523060/0	008.0	43	1	12604896/0	006Y.0	58	1	12728510/0	010.0	55	1
12523060/0	008.0	83	1	12604897/0	001.0	89	2	12728510/0	010a.0	55	1
12523060/0	009.0	29	4	12604899/0	007.0	9	1	12728510/0	012.0	76	1
12523060/0	010.0	63	6	12608950/0	006M.0	44	1	12728680/0	002.0	84	4
12523060/0	010a.0	63	6	12609200/0	008.0	8	2	12728686/0	002e.0	75	2
12523070/0	001.0	75	2	12609260/0	008.0	8	2	12729601/1	002.0	84	4
12523070/0	008.0	46	1	12609260/0	004Y.0	47	2	12729601/1	002a.0	84	4
12523080/0	003.0	26	1	12609260/0	007.0	15	1	12729601/1	002b.0	84	4
12523080/0	009.0	23	2	12609260/0	007.0	15	1	12729601/1	002c.0	84	4
12523090/0	007.0	62	2	12609260/0	009.0	15	2	12729601/1	002d.0	84	4
12540040/0	004M.0	80	1	12610800/0	008.0	7	2	12729601/1	003.0	9	2
12540260/0	005.0	8	1	12620206/0	007.0	16	2	12729601/1	010.0	9	4
12540260/0	005.0	15	2	12620299/0	002.0	32	1	12731350/0	001.0	65	4
12540260/0	005a.0	9	1	12620299/0	002a.0	32	1	12731350/0	002.0	29	2
12540260/0	005a.0	33	2	12620299/0	002b.0	32	1	12731350/0	002a.0	34	2
12540260/0	005b.0	9	1	12620299/0	002c.0	32	1	12731350/0	002b.0	29	2
12540260/0	005b.0	33	2	12620299/0	002d.0	32	1	12731350/0	002c.0	29	2
12540260/0	005c.0	9	1	12620299/0	002e.0	32	1	12731350/0	002d.0	37	2
12540260/0	005c.0	33	2	12622650/0	003.0	4	1	12731350/0	002e.0	37	2
12540260/0	005d.0	33	2	12674550/0	010a.0	19	1	12731350/0	002e.0	37	2
12540260/0	005e.0	11	1	12674701/0	002.0	83	2	12731350/0	004M.0	19	4
12540260/0	005e.0	33	2	12674701/0	002a.0	83	2	12731580/0	001.0	35	1
12540260/0	005f.0	6	1	12674701/0	002b.0	83	2	12731580/0	001.0	82	1
12540260/0	005f.0	33	2	12674701/0	002c.0	83	2	12731580/0	002.0	106	4
12540260/0	005g.0	17	1	12674701/0	002d.0	83	2	12731580/0	002a.0	106	4
12540260/0	005g.0	33	2	12689500/0	010a.0	13	4	12731580/0	002b.0	106	4
12540260/0	005h.0	7	1	12689515/0	001.0	115	1	12731580/0	002c.0	106	4
12540260/0	005h.0	33	2	12689515/0	012.0	5	2	12731580/0	002d.0	106	4
12540260/0	005j.0	11	1	12691100/0	001.0	6	1	12731580/0	002e.0	67	6
12540260/0	005j.0	33	2	12691100/0	001.0	6	1	12731580/0	002e.0	106	4
12543000/0	006M.0	3	1	12691100/0	005.0	25	3	12731601/0	004M.0	4	4
12543000/0	006Y.0	3	1	12691100/0	005a.0	8	3	12731601/0	004Y.0	4	4
12581100/0	001.0	32	2	12691100/0	005b.0	11	3	12734995/0	002.0	103	4
12581200/0	002.0	43	2	12691100/0	005c.0	8	4	12734995/0	002a.0	103	4
12581200/0	002a.0	43	2	12691100/0	005d.0	8	1	12734995/0	002b.0	103	4
12581200/0	002b.0	43	2	12691115/0	005e.0	8	3	12734995/0	002c.0	103	4
12581200/0	002c.0	43	2	12691115/0	006M.0	24	3	12734995/0	002d.0	103	4
12581200/0	002d.0	43	2	12691115/0	005.0	7	1	12734995/0	002e.0	103	4
12581200/0	002e.0	43	2	12691115/0	005a.0	15	1	12734995/0	005d.0	42	1
12582100/0	005b.0	18	3	12691115/0	005b.0	8	1	12735105/0	011.0	2	3
12582100/0	011a.0	25	2	12691115/0	005c.0	11	1	12735105/0	011a.0	2	3
12582100/0	011c.0	25	2	12691115/0	005g.0	11	1	12735106/0	005c.0	42	2
12582101/0	002.0	85	2	12691115/0	005h.0	6	1	12735108/0	005d.0	9	3
12582101/0	002a.0	85	2	12691115/0	005j.0	10	1	12735108/0	005h.0	4	3
12582101/0	002b.0	85	2	12691115/0	006Y.0	24	1	12735109/0	005j.0	8	3
12582101/0	002c.0	85	2	12691200/0	001.0	67	1	12735110/0	001.0	29	2
12582101/0	002d.0	85	2	12691200/0	006Y.0	46	1	12735110/0	001.0	98	2
12582101/0	010.0	10	4	12691400/0	008.0	16	3	12735110/0	002.0	14	2
12583500/0	002.0	53	4	12691400/0	006M.0	25	1	12735110/0	002.0	15	4
12583500/0	002a.0	53	4	12691400/0	006Y.0	25	1	12735110/0	002a.0	15	4
12583500/0	002b.0	53	4	12691700/0	003.0	44	1	12735110/0	002a.0	15	4
12583500/0	002c.0	53	4	12691700/0	007.0	35	2	12735110/0	002b.0	14	2
12583500/0	002d.0	53	4	12691700/0	008.0	15	1	12735110/0	002b.0	15	4
12583500/0	002e.0	53	4	12691800/0	006M.0	45	4	12735110/0	002c.0	14	2
				12691800/0	006Y.0	42	4	12735110/0	002c.0	15	4
				12691900/0	006M.0	45	4	12735110/0	002d.0	14	2
								12735110/0	002d.0	15	4



CODE	TABLE	N.	Q.TY	CODE	TABLE	N.	Q.TY	CODE	TABLE	N.	Q.TY
12735110/0	002e.0	14	2	12792611/0	005j.0	36	2	18375051/1	005c.0	3	2
12735110/0	002e.0	15	4	12792611/0	006M.0	49	2	18375051/1	005d.0	3	2
12735110/0	008.0	30	6	12792611/0	006Y.0	50	1	18375051/1	005e.0	3	2
12735120/0	001.0	101	1	12792611/0	007.0	18	2	18375051/1	005f.0	3	2
12735120/0	006Y.0	49	2	12792611/0	008.0	2	4	18375051/1	005g.0	3	2
12735122/0	010.0	46	1	12792611/0	008.0	72	2	18375051/1	005h.0	3	2
12735122/0	010a.0	46	1	12793101/0	002.0	52	4	18375051/1	005i.0	3	2
12735150/0	006M.0	51	2	12793101/0	002a.0	52	4	18399060/0	006M.0	36	1
12735402/0	002.0	72	4	12793101/0	002b.0	52	4	18399060/0	006Y.0	30	1
12735402/0	002a.0	72	4	12793101/0	002c.0	52	4	18400861/0	011.0	13	1
12735402/0	002b.0	72	4	12793101/0	002d.0	52	4	18400861/0	011a.0	13	1
12735402/0	002c.0	72	4	12793101/0	002e.0	52	4	18400861/0	011b.0	13	1
12735402/0	002d.0	72	4	12793102/0	001.0	7	3	18400861/0	011c.0	13	1
12735402/0	002e.0	72	4	12793102/0	001.0	37	2	18400940/0	006M.0	41	1
12735403/0	002e.0	69	7	12793102/0	005.0	14	2	18400942/0	006M.0	41	1
12735403/0	008.0	62	3	12793102/0	005a.0	32	2	18400950/1	006Y.0	41	1
12735403/0	008.0	65	4	12793102/0	005b.0	32	2	18401001/1	005.0	12	1
12735403/0	010a.0	31	4	12793102/0	005c.0	32	2	18401001/1	005a.0	7	1
12735405/0	002d.0	7	6	12793102/0	005d.0	32	2	18401001/1	005b.0	7	1
12735405/0	01e.0	7	6	12793102/0	005e.0	32	2	18401001/1	005c.0	7	1
12735410/0	010a.0	24	4	12793102/0	005f.0	32	2	18401001/1	005d.0	7	1
12735520/0	004M.0	79	1	12793102/0	005g.0	32	2	18401001/1	005e.0	7	1
12735530/0	005.0	6	2	12793102/0	005h.0	32	2	18401001/1	005f.0	11	1
12735530/0	005a.0	14	2	12793102/0	005i.0	32	2	18401001/1	005g.0	7	1
12735530/0	005b.0	15	4	12793102/0	006Y.0	53	1	18401001/1	005h.0	10	1
12735530/0	005c.0	14	2	12793102/0	008.0	10	2	18401001/1	005j.0	7	1
12735530/0	005d.0	12	2	12793102/0	008.0	23	1	18450060/1	011.0	36	1
12735530/0	005h.0	12	2	12793102/0	008.0	32	1	18450060/1	011a.0	36	1
12735599/0	005f.0	5	1	12793102/0	008.0	45	1	18450060/1	011b.0	36	1
12735602/0	001.0	31	2	12793102/0	010.0	62	6	18450060/1	011c.0	36	1
12735694/0	009.0	24	1	12793102/0	010a.0	62	6	18450065/1	011.0	12	1
12735695/1	009.0	25	1	12793900/0	008.0	19	1	18450065/1	011a.0	12	1
12737310/0	006M.0	2	1	12794980/0	007.0	59	2	18450065/1	011b.0	12	1
12737310/0	006Y.0	2	1	12815200/0	008.0	27	3	18450065/1	011c.0	12	1
12737320/0	006M.0	2	1	12815210/0	004M.0	42	2	18450067/0	011.0	38	1
12737320/0	006Y.0	2	1	12815210/0	004Y.0	22	2	18450067/0	011a.0	38	1
12737450/0	005e.0	14	4	12815210/0	010a.0	73	4	18450068/0	011b.0	38	1
12760520/0	012.0	23	3	12815220/0	010a.0	7	6	18450068/0	011c.0	38	1
12760600/0	004Y.0	48	1	12815220/0	010a.0	25	2	18459100/0	011.0	43	2
12788512/0	002.0	42	2	12815245/0	001.0	11	4	18459100/0	011a.0	43	2
12788512/0	002a.0	42	2	12815245/0	010a.0	8	4	18459100/0	011b.0	43	2
12788512/0	002b.0	42	2	12818690/0	010a.0	86	4	18459100/0	011c.0	43	2
12788512/0	002c.0	42	2	12818700/0	009.0	16	6	18564514/0	008.0	88	2
12788512/0	002d.0	42	2	12818900/0	008.0	42	1	18564861/1	011.0	53	1
12788512/0	002e.0	42	2	14356177/2	013.0	3	1	18564861/1	011a.0	53	1
12789000/0	001.0	91	1	14356184/3	013.0	4	1	18564861/1	011b.0	53	1
12789000/0	001.0	104	2	14356699/0	013.0	10	2	18564861/1	011c.0	53	1
12789000/0	001.0	107	2	14356754/1	013.0	11	1	18564864/1	011.0	54	1
12789020/0	001.0	94	2	14356756/2	013.0	2	1	18564864/1	011a.0	54	1
12789197/0	002.0	25	2	14357190/0	013.0	1	1	18564864/1	011b.0	54	1
12789197/0	002a.0	25	2	14357423/1	013.0	9	1	18564864/1	011c.0	54	1
12789197/0	002b.0	25	2	14357526/0	013.0	8	1	18565351/0	011.0	14	1
12789197/0	002c.0	25	2	14357905/0	013.0	7	1	18565351/0	011a.0	14	1
12789197/0	002d.0	25	2	14357906/0	013.0	5	1	18565351/0	011b.0	14	1
12789197/0	002e.0	25	2	14357907/0	013.0	12	1	18565351/0	011c.0	14	1
12791011/0	001.0	15	5	14357913/0	013.0	13	1	18566110/0	002.0	102	2
12791011/0	001.0	18	6	14357967/0	013.0	6	1	18566110/0	002a.0	102	2
12791011/0	001.0	23	4	14360118/0	013.0	14	1	18566110/0	002b.0	102	2
12791011/0	011.0	22	2	14360715/2	013.0	18	1	18566110/0	002c.0	102	2
12791011/0	011b.0	22	2	14360716/0	013.0	16	1	18566110/0	010a.0	4	4
12791213/1	006M.0	30	4	14360717/0	013.0	15	1	18566110/0	012.0	4	2
12791213/1	008.0	81	1	14360719/0	013.0	17	1	18736110/0	011.0	21	1
12791400/0	005b.0	17	3	18001000/0	010a.0	75	1	18736110/0	011b.0	21	1
12791599/0	011a.0	22	2	18120002/1	011.0	16	1	18737849/0	005.0	11	1
12791599/0	011a.0	44	2	18120002/1	011a.0	16	1	18737849/0	005a.0	6	1
12791599/0	011c.0	22	2	18120002/1	011b.0	16	1	18737849/0	005b.0	6	1
12791599/0	011c.0	44	2	18120002/1	011c.0	16	1	18737849/0	005c.0	6	1
12792099/0	010.0	8	4	18203852/0	011.0	39	1	18737849/0	005d.0	6	1
12792099/0	010.0	14	1	18203852/0	011a.0	39	1	18737849/0	005e.0	6	1
12792611/0	001.0	62	4	18210016/1	011.0	15	1	18737849/0	005f.0	10	1
12792611/0	001.0	78	2	18210016/1	011a.0	15	1	18737849/0	005g.0	6	1
12792611/0	005.0	19	2	18210016/1	011b.0	15	1	18737849/0	005h.0	9	1
12792611/0	005a.0	36	2	18210016/1	011c.0	15	1	18737849/0	005j.0	6	1
12792611/0	005b.0	36	2	18230000/0	011.0	37	1	18737857/0	002d.0	102	2
12792611/0	005c.0	36	2	18230000/0	011a.0	37	1	18737857/0	002e.0	102	2
12792611/0	005d.0	36	2	18230000/0	011b.0	37	1	18737950/0	012.0	61	1
12792611/0	005e.0	36	2	18230000/0	011c.0	37	1	18738206/0	005a.0	12	1
12792611/0	005f.0	36	2	18375051/1	005.0	3	2	18738207/1	005j.0	12	1
12792611/0	005g.0	37	2	18375051/1	005a.0	3	2	18738208/1	005j.0	13	1
12792611/0	005h.0	36	2	18375051/1	005b.0	3	2	18738211/0	005c.0	12	1





CODE	TABLE	N.	Q.TY	CODE	TABLE	N.	Q.TY	CODE	TABLE	N.	Q.TY
18738214/0	005b.0	13	1	25033037/0	004M.0	72	1	25109706/0	002c.0	71	1
18738215/0	005b.0	14	1	25033038/0	004M.0	14	1	25109707/0	002.0	71	1
18738219/0	005g.0	14	1	25033039/0	004M.0	8	1	25109707/0	002a.0	71	1
18738220/0	005g.0	15	1	25033040/0	004M.0	20	1	25109707/0	002b.0	71	1
18738221/0	005f.0	12	1	25033047/0	004M.0	49	1	25109707/0	002c.0	71	1
18738222/0	005f.0	13	1	25033047/0	004Y.0	29	1	25109708/0	002.0	71	1
18738224/0	005.0	4	1	25033053/0	004M.0	72	1	25109708/0	002a.0	71	1
18738227/0	005h.0	11	1	25033060/0	009.0	2	2	25109708/0	002b.0	71	1
18738228/0	005e.0	13	1	25034002/1	003.0	36	4	25109708/0	002c.0	71	1
18738229/0	005e.0	12	1	25038000/0	008.0	14	4	25109709/0	002.0	71	1
18738230/0	005d.0	10	1	25038002/1	006M.0	7	2	25109709/0	002a.0	71	1
19035000/0	009.0	3	2	25038002/1	006Y.0	7	2	25109709/0	002b.0	71	1
19216032/0	009.0	13	4	25038004/0	003.0	1	1	25109709/0	002c.0	71	1
19216033/1	008.0	6	2	25040605/0	007.0	33	4	25109710/0	002.0	71	1
19410605/1	011.0	32	1	25040617/0	003.0	16	1	25109710/0	002a.0	71	1
19410605/1	011a.0	32	1	25060033/0	001.0	93	1	25109710/0	002b.0	71	1
19410605/1	011b.0	v32	1	25060100/3	008.0	29	1	25109710/0	002c.0	71	1
19410605/1	011c.0	32	1	25060101/2	008.0	29	1	25109720/0	002.0	71	1
19410606/0	011.0	31	3	25060113/0	008.0	63	1	25109720/0	002a.0	71	1
19410606/0	011.0	31	4	25060114/0	008.0	64	1	25109720/0	002b.0	71	1
19410606/0	011a.0	31	3	25065002/0	011b.0	25	1	25109720/0	002c.0	71	1
19410606/0	011a.0	31	4	25065017/0	011.0	25	1	25109725/1	002.0	71	1
19410606/0	011b.0	31	3	25065026/0	011.0	35	1	25109726/1	002.0	71	1
19410606/0	011b.0	31	4	25065026/0	011a.0	35	1	25109727/1	002.0	71	1
19410606/0	011c.0	31	3	25065026/0	011b.0	35	1	25109728/1	002.0	71	1
19410606/0	011c.0	31	4	25065026/0	011c.0	35	1	25109744/0	002e.0	71	1
19410609/0	011.0	33	1	25076802/0	002.0	6	1	25109745/0	010a.0	22	1
19410609/0	011a.0	33	1	25076808/0	002a.0	7	1	25109746/0	010a.0	23	1
19410609/0	011b.0	33	1	25076858/0	002d.0	1	1	25109747/0	002e.0	73	1
19410609/0	011c.0	33	1	25076858/0	002e.0	1	1	25109748/0	002e.0	74	1
22034523/0	004Y.0	45	2	25090001/2	002.0	48	1	25110099/1	002.0	64	1
22034523/0	007.0	11	3	25090001/2	002a.0	48	1	25110100/1	002.0	61	1
22061337/0	008.0	80	1	25090001/2	002b.0	48	1	25110132/0	002.0	61	1
22110230/0	003.0	68	2	25090001/2	002c.0	48	1	25110132/0	002a.0	61	1
22110230/0	006M.0	79	2	25090001/2	002d.0	48	1	25110132/0	002b.0	61	1
22110230/0	006Y.0	79	2	25090001/2	002e.0	48	1	25110132/0	002c.0	61	1
22160400/0	003.0	22	1	25090004/0	002a.0	48	1	25110135/0	002.0	61	1
22160400/0	009.0	22	2	25090004/0	002c.0	48	1	25110135/0	002a.0	61	1
22167840/0	001.0	66	1	25090004/0	002e.0	48	1	25110135/0	002b.0	61	1
22450500/0	004M.0	31	1	25108009/0	009.0	31	1	25110135/0	002c.0	61	1
22524970/2	001.0	83	2	25108016/0	005d.0	13	1	25110136/1	002.0	61	1
22524970/2	004M.0	46	1	25108024/0	002a.0	8	1	25110136/1	002a.0	61	1
22524970/2	004Y.0	26	1	25108024/0	002c.0	8	1	25110136/1	002b.0	61	1
22672150/0	003.0	25	3	25108025/0	002d.0	8	1	25110136/1	002c.0	61	1
22672151/0	004M.0	63	1	25108025/0	002e.0	8	1	25110136/1	002d.0	61	1
22672151/0	008.0	74	1	25108028/0	002a.0	8	1	25110239/1	002.0	61	1
22672153/0	004Y.0	46	2	25108028/0	002c.0	8	1	25110239/1	002a.0	61	1
22672153/0	007.0	13	1	25109521/1	006M.0	28	4	25110239/1	002b.0	61	1
22680009/0	004M.0	81	1	25109521/1	006Y.0	28	2	25110239/1	002c.0	61	1
22746600/0	003.0	32	2	25109700/1	002.0	71	1	25110239/1	002d.0	61	1
22746600/0	003.0	41	2	25109700/1	002a.0	71	1	25110240/0	002.0	61	1
22746601/0	004M.0	73	1	25109700/1	002b.0	71	1	25110240/0	002a.0	61	1
24487997/0	004M.0	10	1	25109700/1	002c.0	71	1	25110240/0	002b.0	61	1
24487997/0	004M.0	16	2	25109700/1	002d.0	71	1	25110240/0	002c.0	61	1
24487997/0	004M.0	30	1	25109701/1	002.0	71	1	25110242/0	002.0	61	1
24487997/0	004M.0	78	1	25109701/1	002a.0	71	1	25110242/0	002a.0	61	1
24487998/0	002c.0	5	1	25109701/1	002b.0	71	1	25110242/0	002b.0	61	1
24487998/0	002d.0	36	1	25109701/1	002c.0	71	1	25110242/0	002c.0	61	1
24487998/0	002e.0	36	1	25109701/1	002d.0	71	1	25110260/2	002.0	64	1
24487998/0	007.0	63	2	25109702/1	002.0	71	1	25110260/2	002a.0	64	1
24487998/0	012.0	8	2	25109702/1	002a.0	71	1	25110260/2	002b.0	64	1
24487999/0	012.0	9	1	25109702/1	002b.0	71	1	25110260/2	002c.0	64	1
24487999/0	012.0	46	2	25109702/1	002c.0	71	1	25110265/0	004Y.0	42	1
25020800/1	009.0	10	1	25109702/1	002d.0	71	1	25110266/0	004Y.0	43	1
25020801/2	009.0	11	1	25109703/1	002.0	71	1	25110267/0	004Y.0	2	1
25031501/0	011b.0	4	1	25109703/1	002a.0	71	1	25110269/0	004M.0	2	1
25031501/0	011c.0	4	1	25109703/1	002b.0	71	1	25110270/0	002.0	63	1
25032001/1	010.0	3	1	25109703/1	002c.0	71	1	25110270/0	002a.0	63	1
25032002/1	010.0	4	1	25109703/1	002d.0	71	1	25110270/0	002b.0	63	1
25032006/0	010a.0	32	1	25109704/0	002.0	71	1	25110270/0	002c.0	63	1
25032007/0	010a.0	33	1	25109704/0	002a.0	71	1	25110278/1	002d.0	63	1
25032013/0	010a.0	11	1	25109704/0	002b.0	71	1	25110278/1	002e.0	63	1
25032015/0	010a.0	12	1	25109704/0	002c.0	71	1	25110279/0	002d.0	64	1
25033002/0	007.0	6	1	25109705/0	002.0	71	1	25110279/0	002e.0	64	1
25033003/1	003.0	31	1	25109705/0	002a.0	71	1	25110301/0	002.0	82	1
25033029/0	007.0	50	2	25109705/0	002b.0	71	1	25110301/0	002b.0	82	1
25033031/0	004Y.0	50	1	25109705/0	002c.0	71	1	25110302/0	010a.0	21	1
25033033/0	006Y.0	57	1	25109706/0	002.0	71	1	25110303/0	002e.0	61	1
25033034/0	004M.0	49	1	25109706/0	002a.0	71	1	25110306/0	002e.0	61	1
25033034/0	004Y.0	29	1	25109706/0	002b.0	71	1	25120152/1	002.0	16	1



CODE	TABLE	N.	Q.TY	CODE	TABLE	N.	Q.TY	CODE	TABLE	N.	Q.TY
25120152/1	002b.0	16	1	25394501/0	002.0	45	1	25510053/1	007.0	52	2
25120152/1	002c.0	16	1	25394501/0	002a.0	45	1	25510053/1	007.0	52	6
25120153/1	002a.0	16	1	25394501/0	002b.0	45	1	25510054/0	004Y.0	51	1
25120153/1	002d.0	16	1	25394501/0	002c.0	45	1	25510054/0	004Y.0	56	1
25120171/1	002a.0	16	1	25394501/0	002d.0	45	1	25510055/0	007.0	45	2
25120171/1	002d.0	16	1	25394501/0	002e.0	45	1	25510056/0	007.0	38	2
25120185/0	002e.0	16	1	25394504/1	007.0	7	1	25510056/0	007.0	56	2
25120200/0	002a.0	18	2	25394508/0	010.0	13	1	25510062/0	004M.0	21	1
25120200/0	002d.0	18	2	25394508/0	010a.0	18	1	25510063/0	004M.0	5	1
25120200/0	002e.0	18	2	25394509/1	004M.0	51	1	25510064/0	004M.0	11	1
25120231/0	002.0	33	1	25394509/1	004Y.0	30	1	25510065/1	003.0	17	1
25120231/0	002a.0	33	1	25394510/0	004M.0	71	1	25510068/0	002c.0	3	2
25120231/0	002b.0	33	1	25394510/0	008.0	87	1	25510068/0	002d.0	34	2
25120231/0	002c.0	33	1	25410858/0	002.0	5	1	25510068/0	002e.0	34	2
25120232/0	010a.0	34	1	25410860/0	002a.0	5	1	25510070/0	007.0	61	2
25120233/0	002e.0	49	1	25410861/0	002a.0	6	1	25510072/0	009.0	27	4
25120234/0	002e.0	20	1	25410865/0	002b.0	6	1	25510074/0	012.0	74	1
25122000/2	001.0	72	2	25410868/0	002c.0	7	1	25510080/0	010.0	43	1
25122200/2	003.0	63	4	25410869/0	002c.0	6	1	25510080/0	010a.0	43	1
25140091/0	012.0	72	1	25410874/0	002d.0	5	1	25510083/0	010a.0	76	1
25140092/0	012.0	72	1	25410874/0	002e.0	5	1	25510083/0	010a.0	88	1
25160002/0	008.0	35	1	25410875/0	002d.0	6	1	25519997/1	012.0	22	1
25160003/0	008.0	13	4	25410875/0	002e.0	6	1	25520095/0	003.0	2	1
25160005/0	003.0	47	1	25420004/0	011.0	4	1	25547015/0	002.0	2	1
25160007/0	008.0	41	1	25420005/0	011.0	4	1	25547015/0	002b.0	2	1
25160018/0	006M.0	22	3	25420005/0	011a.0	4	1	25547015/0	002b.0	82	1
25160021/0	006M.0	35	1	25420007/0	011.0	4	1	25547015/0	002c.0	2	1
25160021/0	006Y.0	29	1	25420007/0	011a.0	4	1	25547016/2	002.0	2	1
25160023/0	006Y.0	76	2	25430202/0	001.0	88	1	25547016/2	002.0	82	1
25160024/1	006M.0	23	1	25430203/0	001.0	81	1	25547016/2	002b.0	2	1
25160024/1	006Y.0	23	1	25430205/1	001.0	71	2	25547016/2	002b.0	82	1
25160025/0	007.0	12	1	25430208/0	007.0	8	1	25547016/2	002c.0	2	1
25160027/0	006M.0	9	1	25430209/0	003.0	72	8	25547024/0	002.0	2	1
25160027/0	006Y.0	9	1	25430209/0	006M.0	82	8	25547024/0	002.0	82	1
25160028/0	006M.0	76	2	25430209/0	006Y.0	82	8	25547024/0	002b.0	2	1
25160030/0	006Y.0	22	1	25430210/0	006M.0	37	1	25547024/0	002b.0	82	1
25160031/0	006M.0	76	2	25430210/0	006Y.0	31	1	25547024/0	002c.0	2	1
25160032/0	001.0	113	1	25430210/0	008.0	49	1	25547025/1	002a.0	2	1
25160035/0	005d.0	15	3	25430210/0	010.0	45	1	25547025/1	002a.0	82	1
25160035/0	005h.0	14	3	25430210/0	010a.0	45	1	25547025/1	002c.0	82	1
25160501/0	009.0	14	2	25430213/0	004M.0	52	1	25547025/1	002d.0	82	1
25207000/1	008.0	37	1	25430213/0	004Y.0	31	1	25547026/0	002a.0	2	1
25207120/0	002d.0	2	1	25430215/0	002.0	19	2	25547026/0	002a.0	82	1
25207120/0	002e.0	2	1	25430215/0	002b.0	19	2	25547026/0	002c.0	82	1
25207121/0	002d.0	3	1	25430215/0	002c.0	19	2	25547028/0	002a.0	2	1
25207121/0	002e.0	3	1	25430218/0	007.0	64	1	25547028/0	002a.0	82	1
25207126/0	010a.0	29	1	25430219/0	006M.0	15	1	25547028/0	002c.0	82	1
25207127/0	010a.0	30	1	25430219/0	006Y.0	15	1	25547081/1	004M.0	3	1
25207129/0	002e.0	76	1	25430220/0	008.0	49	1	25547081/1	004Y.0	3	1
25207148/0	002e.0	76	1	25430223/2	001.0	90	1	25547089/0	002.0	104	1
25207153/0	002e.0	76	1	25430226/0	004M.0	66	1	25547089/0	002a.0	104	1
25207200/0	009.0	12	2	25430227/0	008.0	77	1	25547089/0	002b.0	104	1
25253001/0	004M.0	45	1	25430230/0	011.0	17	1	25547091/0	002.0	105	1
25253001/0	004Y.0	25	1	25430230/0	011a.0	17	1	25547091/0	002a.0	105	1
25253004/0	012.0	79	2	25430230/0	011b.0	17	1	25547091/0	002b.0	105	1
25260000/0	002.0	18	2	25430230/0	011c.0	17	1	25547099/0	002b.0	107	2
25260000/0	002a.0	29	2	25430235/0	001.0	102	1	25547109/1	002c.0	104	2
25260000/0	002b.0	18	2	25430236/0	004M.0	22	1	25547109/1	002d.0	104	2
25260000/0	002c.0	18	2	25430236/0	004Y.0	7	1	25547109/1	002e.0	104	2
25260000/0	002d.0	29	2	25430238/0	001.0	34	1	25547131/0	010a.0	6	1
25260000/0	002e.0	19	2	25430240/0	012.0	75	1	25547144/0	002.0	2	1
25270317/0	008.0	38	1	25430241/0	001.0	114	1	25547144/0	002.0	82	1
25280000/1	012.0	77	1	25463200/0	009.0	18	2	25570000/2	003.0	3	1
25290000/0	002.0	28	1	25470901/0	007.0	4	1	25580014/1	001.0	109	1
25290000/0	002a.0	28	1	25485001/0	002b.0	5	1	25580018/0	006M.0	32	2
25290000/0	002b.0	28	1	25486020/0	001.0	106	1	25580019/0	001.0	25	1
25290000/0	002c.0	28	1	25510000/0	001.0	87	1	25580020/0	002.0	62	1
25290000/0	002d.0	28	1	25510011/0	007.0	5	1	25580020/0	002a.0	62	1
25290001/0	002e.0	28	1	25510021/1	012.0	45	1	25580020/0	002b.0	62	1
25318109/0	001.0	86	1	25510022/0	012.0	7	2	25580020/0	002c.0	62	1
25318115/1	008.0	36	1	25510023/1	002.0	3	2	25580020/0	002d.0	62	1
25318119/0	008.0	36	1	25510023/1	002a.0	3	2	25580020/0	002e.0	62	1
25318124/0	010.0	53	1	25510028/1	005g.0	8	4	25580022/0	001.0	112	1
25318124/0	010a.0	53	1	25510035/0	004M.0	61	1	25590000/0	003.0	64	2
25318153/1	007.0	48	2	25510036/1	006M.0	18	1	25590001/0	006M.0	73	2
25318157/0	006Y.0	52	1	25510036/1	006Y.0	18	1	25590001/0	006Y.0	73	2
25318161/0	007.0	34	2	25510039/0	002b.0	3	2	25590002/0	003.0	64	2
25318169/0	004M.0	77	1	25510048/0	007.0	53	2	25590003/0	006M.0	73	2
25394005/0	012.0	73	1	25510051/0	009.0	32	2	25590003/0	006Y.0	73	2
25394009/0	010a.0	28	1	25510052/0	004Y.0	6	1	25598050/0	005.0	10	1





CODE	TABLE	N.	Q.TY	CODE	TABLE	N.	Q.TY	CODE	TABLE	N.	Q.TY
25598050/0	005a.0	5	1	25722459/0	002d.0	51	1	25961214/0	002e.0	31	1
25598050/0	005b.0	5	1	25722459/0	002e.0	51	1	27430561/0	005g.0	10	1
25598050/0	005c.0	5	1	25730000/0	002.0	7	1	27430562/0	005f.0	14	1
25598050/0	005d.0	5	1	25730001/0	002.0	7	1	27546015/1	004M.0	18	2
25598050/0	005e.0	5	1	25730016/0	002d.0	9	1	27546019/0	001.0	30	1
25598050/0	005j.0	5	1	25730016/0	002e.0	9	1	27590051/0	003.0	64	2
25598052/0	005f.0	9	1	25735110/3	002.0	23	1	27590053/0	003.0	64	2
25599000/0	002d.0	65	1	25735110/3	002a.0	23	1	27598060/0	005h.0	8	1
25599000/0	002e.0	65	1	25735110/3	002b.0	23	1	27598061/1	005g.0	5	1
25599001/0	002d.0	66	1	25735110/3	002c.0	23	1	33320504/0	011.0	52	1
25599001/0	002e.0	66	1	25735110/3	002d.0	23	1	33320504/0	011a.0	52	1
25600007/0	002.0	21	1	25735110/3	002e.0	22	1	33320504/0	011b.0	52	1
25600007/0	002b.0	21	1	25735111/3	002.0	23	1	33320506/0	011c.0	52	1
25600007/0	002c.0	21	1	25735111/3	002a.0	23	1	33320506/0	011.0	51	5
25600009/0	002a.0	21	1	25735111/3	002b.0	23	1	33320506/0	011a.0	51	5
25600009/0	002d.0	21	1	25735111/3	002c.0	23	1	33320506/0	011b.0	51	5
25600031/0	005c.0	41	1	25735111/3	002d.0	23	1	33320506/0	011c.0	51	5
25600038/0	005d.0	41	1	25735111/3	002e.0	23	1	33340036/0	011.0	8	1
25600041/0	010.0	51	1	25735506/1	007.0	17	1	33340036/0	011a.0	8	1
25600041/0	010a.0	51	1	25735507/0	003.0	20	1	33340036/0	011b.0	8	1
25600042/0	010.0	52	1	25737002/0	001.0	72	2	33340036/0	011b.0	8	1
25600042/0	010a.0	52	1	25743000/0	003.0	5	1	33340036/0	011c.0	8	1
25600047/0	010.0	56	1	25755016/0	001.0	103	1	33340036/0	011c.0	8	1
25600047/0	010a.0	56	1	25755025/1	001.0	97	1	33340040/0	011.0	8	1
25600048/0	010.0	57	1	25755031/0	010.0	42	1	33340040/0	011a.0	8	1
25600048/0	010a.0	57	1	25755031/0	010a.0	42	1	33340040/0	011b.0	8	1
25600049/0	008.0	61	1	25774213/0	012.0	43	1	33340040/0	011b.0	8	2
25600050/0	008.0	61	1	25774273/1	001.0	5	2	33340040/0	011c.0	8	1
25600051/0	002.0	22	1	25774275/0	004M.0	25	1	33340040/0	011c.0	8	1
25600051/0	002a.0	22	1	25774275/0	004Y.0	10	1	33500030/0	011.0	42	2
25600051/0	002b.0	22	1	25774285/0	006M.0	48	2	33500030/0	011a.0	42	2
25600051/0	002c.0	22	1	25774315/0	010.0	41	1	33500030/0	011b.0	42	2
25600051/0	002d.0	22	1	25774315/0	010a.0	41	1	33500030/0	011c.0	42	2
25600060/0	010a.0	79	1	25774317/0	010a.0	72	2	35062001/0	006Y.0	4	1
25601549/0	008.0	31	1	25785125/0	006M.0	29	1	35062011/0	006M.0	4	1
25601550/0	008.0	31	1	25785125/0	006M.0	38	1	35062811/0	008.0	48	1
25601554/0	006M.0	10	1	25785133/3	001.0	14	1	35062812/0	008.0	48	1
25601554/0	006Y.0	10	1	25785137/0	001.0	22	1	35062813/0	008.0	48	1
25601555/0	006M.0	17	1	25785141/0	001.0	28	1	35062814/0	008.0	48	1
25601555/0	006Y.0	17	1	25785143/0	004M.0	41	1	35065600/0	008.0	26	1
25601555/0	008.0	40	1	25785143/0	004Y.0	21	1	35065601/0	008.0	26	1
25601559/1	008.0	5	2	25785147/0	001.0	85	1	82000200/1	002.0	41	1
25601560/0	008.0	21	2	25785149/2	001.0	80	1	82000200/1	002a.0	41	1
25601561/0	008.0	5	2	25785197/0	010a.0	78	1	82000200/1	002b.0	41	1
25601562/0	008.0	21	2	25785213/0	003.0	8	1	82000200/1	002c.0	41	1
25601566/0	006Y.0	1	1	25785227/0	006M.0	38	1	82000200/1	002d.0	41	1
25601567/0	006M.0	1	1	25785228/0	002e.0	68	1	82000200/1	002e.0	41	1
25601568/0	006Y.0	1	1	25795000/1	002.0	24	1	82000201/2	002.0	41	1
25601569/0	006M.0	1	1	25795000/1	002a.0	24	1	82000201/2	002a.0	41	1
25601570/0	006M.0	21	4	25795000/1	002b.0	24	1	82000201/2	002b.0	41	1
25601570/0	006Y.0	21	2	25795000/1	002c.0	24	1	82000201/2	002c.0	41	1
25605000/1	007.0	3	1	25795000/1	002d.0	24	1	82000201/2	002d.0	41	1
25650037/0	008.0	9	1	25795000/1	002e.0	24	1	82000201/2	002e.0	41	1
25650065/0	001.0	17	2	25808017/0	010a.0	3	1	82000204/1	002a.0	41	1
25650067/0	001.0	20	1	25840001/0	003.0	40	1	82000204/1	002c.0	41	1
25670005/1	003.0	66	2	25840010/1	006M.0	13	1	82000204/1	002e.0	41	1
25670005/1	006M.0	77	2	25840010/1	006Y.0	13	1	82000405/0	004M.0	17	1
25670005/1	006Y.0	75	4	25840011/1	012.0	78	1	82000477/2	007.0	43	2
25670007/0	008.0	24	1	25869003/1	005c.0	2	1	82000479/0	007.0	10	1
25670007/0	008.0	33	1	25869012/1	005d.0	2	1	82000481/0	004Y.0	44	1
25670008/1	007.0	41	4	25869016/1	005.0	2	1	82000487/0	004Y.0	5	1
25670008/1	007.0	57	4	25869016/1	005a.0	2	1	82000507/0	010a.0	71	1
25670011/0	004M.0	13	2	25869016/1	005b.0	2	1	82000590/0	003.0	62	2
25670011/0	004M.0	47	1	25869016/1	005h.0	2	1	82000592/0	006M.0	72	2
25670011/0	004Y.0	27	1	25869016/1	005j.0	2	1	82000592/0	006Y.0	72	2
25670011/0	006Y.0	55	1	25869018/1	005e.0	2	1	82004347/0	009.0	21	1
25670011/0	007.0	51	6	25869027/1	005f.0	2	1	82004348/0	009.0	20	1
25670012/0	003.0	19	2	25869029/1	010.0	12	1	82004349/0	009.0	21	1
25670014/0	003.0	21	1	25869029/1	010a.0	17	1	82004350/0	009.0	20	1
25670017/0	006M.0	80	2	25869033/1	005g.0	2	1	82004607/1	008.0	85	1
25670017/0	006Y.0	77	2	25869043/0	012.0	3	1	82004608/0	008.0	91	1
25690001/0	010a.0	84	2	25943001/0	001.0	73	2	82004609/0	008.0	91	1
25722412/1	011.0	1	1	25950000/0	003.0	65	2	82004616/0	008.0	85	1
25722412/1	011a.0	1	1	25950000/0	006M.0	74	2	82033105/0	012.0	44	1
25722413/1	011.0	1	1	25950000/0	006Y.0	74	2	82034001/3	003.0	35	1
25722413/1	011a.0	1	1	25961213/0	002.0	31	1	82040070/0	011.0	41	1
25722450/1	002.0	51	1	25961213/0	002a.0	31	1	82040070/0	011a.0	41	1
25722450/1	002b.0	51	1	25961213/0	002b.0	31	1	82040073/0	011.0	41	1
25722451/2	002a.0	51	1	25961213/0	002c.0	31	1	82040073/0	011a.0	41	1
25722451/2	002c.0	51	1	25961214/0	002d.0	31	1	82040073/0	011b.0	41	1



CODE	TABLE	N.	Q.TY	CODE	TABLE	N.	Q.TY	CODE	TABLE	N.	Q.TY
82040073/0	011c.0	41	1	82565028/0	009.0	—	1	82869006/1	002c.0	101	1
82040134/0	011c.0	11	1	82598005/2	005b.0	35	1	82869015/0	002b.0	101	1
82040135/0	011b.0	11	1	82598005/2	005f.0	35	1	82869019/0	002d.0	101	1
82040137/0	011.0	11	1	82598009/2	005.0	18	1	82869019/0	002e.0	101	1
82040140/0	011a.0	11	1	82598009/2	005a.0	35	1	99900005/0	012.0	41	1
82076802/2	002.0	1	1	82598013/1	005j.0	35	1	99900015/1	012.0	1	1
82076803/0	002.0	1	1	82598015/1	005e.0	35	1	99900030/6	012.0	21	1
82076808/0	002.0	1	1	82598015/1	005g.0	36	1	99900045/0	012.0	71	1
82076817/2	002b.0	1	1	82598017/0	005c.0	35	1	99900046/0	012.0	71	1
82076818/1	002b.0	1	1	82598029/0	005h.0	35	1				
82076831/1	002b.0	1	1	82598031/0	005d.0	35	1				
82076841/3	002a.0	1	1	82601503/0	006M.0	42	1				
82076843/2	002a.0	1	1	82650038/0	010.0	6	1				
82076847/2	002a.0	1	1	82650041/1	001.0	61	1				
82076917/1	002c.0	1	1	82650043/0	010a.0	5	1				
82076918/0	002c.0	1	1	82650209/0	010a.0	82	1				
82076919/0	002c.0	1	1	82680002/2	003.0	61	2				
82076932/0	002.0	1	1	82680003/0	006M.0	71	2				
82105982/0	010a.0	16	1	82680003/0	006Y.0	71	2				
82106000/2	010.0	7	1	82680005/1	003.0	61	2				
82110200/1	002a.0	81	1	82680006/0	006M.0	71	2				
82110200/1	002c.0	81	1	82680006/0	006Y.0	71	2				
82110200/1	002d.0	81	1	82680007/1	003.0	61	2				
82110201/0	002a.0	81	1	82680008/1	003.0	61	2				
82110201/0	002c.0	81	1	82700002/0	009.0	26	4				
82110203/0	002a.0	81	1	82722420/0	011b.0	1	1				
82110203/0	002c.0	81	1	82722420/0	011c.0	1	1				
82110207/1	002.0	81	1	82722421/0	011b.0	1	1				
82110207/1	002b.0	81	1	82722421/0	011c.0	1	1				
82110208/0	002.0	81	1	82722422/0	011b.0	1	1				
82110208/0	002b.0	81	1	82722422/0	011c.0	1	1				
82110210/0	002.0	81	1	82722423/0	011b.0	1	1				
82110210/0	002b.0	81	1	82722423/0	011c.0	1	1				
82110235/0	002.0	81	1	82735502/0	012.0	42	1				
82110245/0	002.0	81	1	82750003/0	005b.0	31	1				
82110245/0	002b.0	81	1	82750003/0	005e.0	31	1				
82110252/0	003.0	71	2	82750003/0	005f.0	31	1				
82110253/0	006M.0	81	2	82750003/0	005g.0	34	1				
82110253/0	006Y.0	81	2	82750003/0	005j.0	31	1				
82180027/1	010.0	16	1	82750004/0	005.0	16	1				
82180037/2	010a.0	35	1	82750004/0	005a.0	31	1				
82180038/1	010a.0	35	1	82750004/0	005h.0	31	1				
82180050/0	012.0	51	1	82750005/0	005c.0	31	1				
82180052/0	012.0	51	1	82750008/0	005d.0	31	1				
82207200/1	009.0	8	1	82774206/0	004M.0	64	1				
82207201/2	009.0	9	1	82774207/0	001.0	77	1				
82230348/0	003.0	39	1	82774225/1	010.0	61	2				
82230349/0	003.0	38	1	82774225/1	010a.0	61	2				
82230359/0	003.0	39	1	82774227/0	008.0	71	1				
82230361/0	003.0	38	1	82774229/0	008.0	75	1				
82300002/1	007.0	1	1	82774245/0	010a.0	61	2				
82318101/0	003.0	43	1	82785021/6	002.0	12	1				
82318139/0	007.0	2	1	82785021/6	002a.0	12	1				
82318155/0	007.0	31	1	82785021/6	002b.0	12	1				
82318157/0	007.0	32	1	82785021/6	002c.0	12	1				
82318159/0	007.0	31	1	82785021/6	002d.0	12	1				
82318161/0	007.0	32	1	82785021/6	002e.0	12	1				
82318165/1	006M.0	5	1	82785022/7	002.0	11	1				
82318165/1	006Y.0	5	1	82785022/7	002a.0	11	1				
82318177/1	008.0	76	1	82785022/7	002b.0	11	1				
82318179/0	004M.0	65	1	82785022/7	002c.0	11	1				
82318185/0	003.0	43	1	82785022/7	002d.0	11	1				
82394001/2	010.0	5	1	82785022/7	002e.0	11	1				
82394607/0	002d.0	4	1	82785084/1	008.0	4	1				
82394607/0	002e.0	4	1	82785109/0	006Y.0	45	1				
82400003/1	012.0	2	1	82785137/0	002.0	13	1				
82500011/2	004Y.0	1	1	82785137/0	002a.0	13	1				
82500013/0	004Y.0	41	1	82785137/0	002b.0	13	1				
82500015/1	004M.0	1	1	82785137/0	002c.0	13	1				
82510041/1	001.0	9	1	82785137/0	002d.0	13	1				
82510043/1	001.0	10	1	82785137/0	002e.0	13	1				
82547003/2	008.0	1	1	82785147/0	010a.0	83	2				
82547005/1	008.0	1	1	82800002/2	010.0	2	1				
82547011/6	001.0	2	1	82800051/0	010.0	1	1				
82547039/0	001.0	2	1	82800075/0	001.0	1	1				
82565023/0	009.0	—	1	82800079/0	010a.0	1	1				
82565024/0	009.0	—	1	82800089/0	010a.0	2	1				
82565025/0	009.0	1	1	82869006/1	002.0	101	1				
82565026/1	009.0	1	1	82869006/1	002a.0	101	1				
82565027/0	009.0	—	1	82869006/1	002b.0	101	1				