

TC
TCP
TCR
hydro
hydro
hydro

www.emc-motocult.com

CATALOGO PEZZI DI RICAMBIO
SPARE PARTS CATALOGUE
CATALOGUE DE PIECES
ERSATZTEILKATALOG
2000

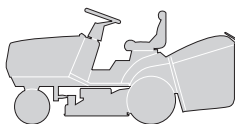

COME USARE IL CATALOGO

HOW TO USE THE CATALOGUE

COMMENT UTILISER LE CATALOGUE

WIE IST DER KATALOG ZU BENUTZEN

1. Generalità

Questo catalogo contiene tutte le informazioni necessarie per ordinare correttamente i pezzi di ricambio.

1. General information

This catalogue contains all the information necessary for correctly ordering spare parts.

1. Généralités

Ce catalogue contient toutes les indications nécessaires pour commander correctement les pièces détachées.

1. Allgemeines

Dieser Katalog enthält alle Informationen, die für die korrekte Bestellung von Ersatzteilen erforderlich sind.

2. Struttura del catalogo

In ogni pagina del catalogo sono riportate le seguenti indicazioni:

2. Structure of the catalogue

Each page of the catalogue has these indications:

2. Structure du catalogue

Les indications suivantes sont reportées sur chaque page du catalogue:

2. Aufbau des Katalogs

Auf jeder Seite des Katalogs sind die folgenden Angaben wiedergegeben:

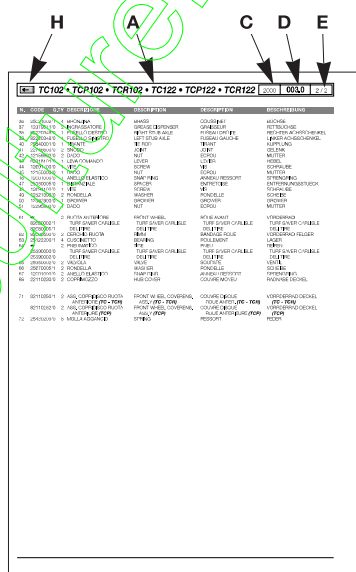
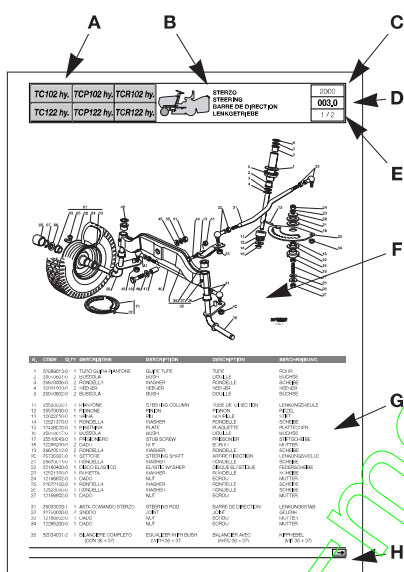

A. Macchina o serie di macchine per le quali la pagina è valida.

A. Machine or machine series to which the page applies.

A. La machine ou la série de machines auxquelles se réfère la page.

A. Maschine oder Serie der Maschine, für welche die Seite gültig ist.

B. Indicazione del gruppo con la raffigurazione in miniatura della sua collocazione sulla macchina.

B. Indication of the unit with a miniature drawing showing its position on the machine.

B. L'indication du groupe avec la représentation en miniature de sa position sur la machine.

B. Bezeichnung der Gruppe mit einer Miniaturdarstellung ihrer Anbringung auf der Maschine.

C. Anno di produzione della macchina a cui si riferisce.

C. Year of production of the machine concerned.

C. L'année de fabrication de la machine concernée.

C. Herstellungsjahr der betreffenden Maschine.

D. Numerazione progressiva della tavola, secondo il seguente criterio:

D. Progressive numbering of the table, arranged as follows:

D. La numérotation progressive du tableau, selon le critère suivant:

D. Progressive Numerierung der Tafel nach folgendem Kriterium:

- le prime due cifre indicano il numero progressivo;
- le eventuali lettere che seguono indicano le diverse versioni alternative di quel gruppo;
- la cifra dopo il punto indica un eventuale aggiornamento nel corso della annualità indicata al punto 3.

- the first two numbers are the progressive number;
- any letters that follow will indicate the various alternative versions of that unit;
- the number after the dot is for any updates during the year given at point 3.

- les deux premiers chiffres indiquent le numéro progressif;
- les éventuelles lettres qui suivent indiquent les différentes versions alternatives de ce groupe;
- le chiffre après le point indique l'éventuelle mise à jour effectuée au cours de l'année indiquée au point 3.

- die ersten zwei Ziffern bezeichnen die progressive Nummer;
- die eventuellen Buchstaben, die folgen, bezeichnen die verschiedenen alternativen Versionen dieser Gruppe;
- die Ziffer nach dem Punkt bezeichnet einen eventuellen neueren Stand im Laufe des Jahrgangs, der in Punkt 3 angegeben ist.

Esempio:

Example:

Exemple

Beispiel:

005b.0 =
 005 Gruppo Motore
 b 18 - 20 HP B&S
 .0 Prima stesura

005b.0 =
 005 Engine unit
 b 18 - 20 HP B&S
 .0 First copy

005b.0 =
 005 Groupe Moteur
 b 18 - 20 HP B&S
 .0 Première rédaction

005b.0 =
 005 Motorgruppe
 b 18 - 20 HP B&S
 .0 Erste Ausgabe



E. Numero della pagina e numero totale delle pagine necessarie per la descrizione del gruppo.

E. Page number and total number of pages necessary for the description of the unit.

E. Numéro de la page et nombre total des pages nécessaires pour la description du groupe.

E. Seitenzahl und Gesamtzahl der Seiten, die für die Beschreibung der Gruppe erforderlich sind.

F. Vista esplosa del gruppo.

F. Exploded view of the unit.

F. Vue éclatée du groupe.

F. Explosionszeichnung der Gruppe.

G. Descrizione completa dei singoli particolari, con codice e quantità di pezzi.

G. Full description of each part, with code number and number of pieces.

G. Description complète de chaque élément, avec code et quantité des pièces.

G. Vollständige Beschreibung der Einzelteile, mit Kodenummer und Menge der Teile.

H. Indicazione della presenza di altre pagine di seguito.

H. Indication of additional pages.

H. Indication de la présence d'autres pages successives.

H. Angabe über die Präsenz weiterer folgender Seiten.

Nelle pagine di seguito, sono riportate nuovamente le indicazioni relative ai punti A - C - D - E - G e H.

The additional pages repeat the indications as at points A - C - D - E - G and H.

Les pages qui suivent reportent, elles aussi, les indications concernant les points A - C - D - E - G et H.

Auf den nachfolgenden Seiten sind die Bezeichnungen, die sich auf die Punkte A - C - D - E - G und H beziehen, erneut wiedergegeben.

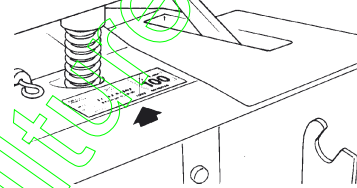
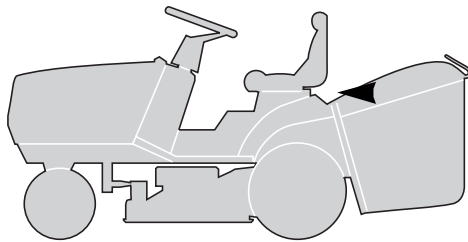

3. Ordine di ricambi

Prima di formulare un ordine di ricambi, accertare che il catalogo corrisponda all'anno di costruzione della macchina, e riportato sulla targhetta di identificazione.

Ogni ordine di ricambi deve necessariamente contenere:

- modello della macchina;
- quantità di pezzi richiesta;
- descrizione (eventuale);
- numero di codice del pezzo;
- destinatario
- mezzo di spedizione.

Esempio di ordinazione:

Su una macchina TCP122 del 2000, con motore B&S da 18 HP si deve sostituire il silenziatore di scarico. Tale particolare è raffigurato nella tavola **005b.0** alla posizione **34**, a cui corrisponde il codice **18716131/1**.

L'ordinazione sarà quindi:

per TCP122:
n. 1 silenziatore cod. 18716131/1
da inviare a
a mezzo

Nota

Per le parti non codificate del motore e della trasmissione contrassegnate con (*), occorre rivolgersi al Costruttore.

3. Spare parts order

Before putting in an order for spare parts, make sure that the catalogue is the one applying to the machine's year of manufacture, as shown on the identification plate attached to the machine.

Each spare parts order must include:

- the model of the machine;
- the number of parts required;
- description (incidental);
- the code number for the item;
- the destination;
- the method of shipping.

An example of an order:

The exhaust pipe silencer on a TCP122 machine, produced in 2000 with an B&S 18 HP engine, must be replaced. This part is shown in table **005b.0** in position **34**, and has the code number **18716131/1**.

The order will therefore be:

for TCP122:
1 silencer - code 18716131/1
to be sent to
method of shipping

Note

For parts of the engine and the transmission without code numbers, marked by (*), it's necessary to contact the manufacturer.

3. Commande pièces détachées

Avant de passer une commande pour des pièces détachées, s'assurer que le catalogue est celui correspondant à l'année de fabrication de la machine reportée sur la plaquette d'identification.

Chaque commande de pièces détachées doit obligatoirement contenir:

- modèle de la machine;
- quantité de pièces demandée;
- description (éventuelle);
- numéro de code de la pièce;
- le destinataire;
- le moyen de transport.

Exemple de commande:

Sur une machine TCP102 du 2000, avec moteur B&S de 18 CH, il faut remplacer le silencieux d'échappement. Cette pièce est représentée sur le tableau **005b.0** à la position **34**, correspondant au code **18716131/1**.

La commande sera donc formulée de la façon suivante:

pour TCP122:
1 silencieux - code 18716131/1
à envoyer à
par

Remarque

Pour les pièces non codées du moteur et de la transmission, indiquées avec (*), il faut s'adresser au Fabricant.

3. Ersatzteilbestellungen

Ehe eine Ersatzteilbestellung geschrieben wird, muß man sich vergewissern, daß der Katalog mit dem Herstellungsjahr der Maschine übereinstimmt, oder mit dem auf dem Kennzeichenschild wiedergegeben.

Jede Ersatzteilbestellung muß enthalten:

- Modell der Maschine;
- Menge der angeforderten Teile;
- Bezeichnung (eventuell);
- Artikelnummer des Teils;
- Empfänger;
- Versandart.

Beispiel einer Bestellung:

Auf einer Maschine TCP122 von 2000, mit Motor B&S mit 18 PS muß der Auspufftopf ersetzt werden. Dieses Einzelteil ist auf der Tafel **005b.0** unter der Position **34** dargestellt, der dem Code **18716131/1** entspricht.

Die Bestellung lautet demnach:

Für TCP122:
1 Auspuff - Kode 18716131/1
zu versenden an
mit

Anmerkung

Für die nicht codierten Teile des Motors und des Antriebs, die mit (*) gekennzeichnet sind, muß man sich an den Hersteller wenden.

TC102 hy. TCP102 hy. TCR102 hy.

TC122 hy. TCP122 hy. TCR122 hy.

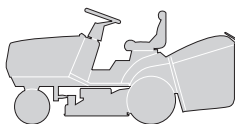





**INDICE DELLE TAVOLE
INDEX OF TABLES
SOMMAIRE DES TABLEAUX
INHALT DER TAFELN**

2000

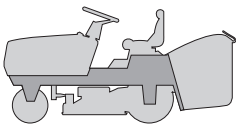
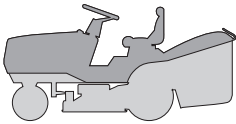
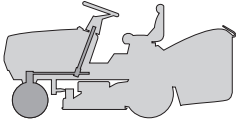
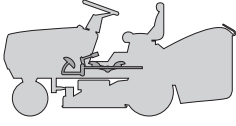
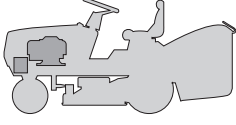
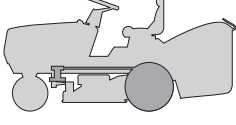
000.0

3 / 8

GRUPPO / UNIT / GROUPE / GRUPPE		TC102 hydro	TCP102 hydro	TCR102 hydro	TC122 hydro	TCP122 hydro	TCR122 hydro
	TELAIO CHASSIS CHASSIS RAHMENSATZ	001	001	001	001	001	001
	CORROZZERIA BODY CARROSSERIE KARROSSERIE	002	002a	002b	002	002a	002b
	STERZO STEERING BARRE DE DIRECTION LENKGETRIEBE	003	003	003	003	003	003
	COMANDO TRASMISSIONE E FRENO DRIVE AND BRAKE CONTROLS COMMANDE TRANSMISSION ET FREIN GETRIEBE UND BREMSE ANTRIEB	004	004	004	004	004	004
	MOTORE ENGINE MOTEUR MOTOR 12 - 12,5 - 13 HP B&S	005	-	005	-	-	-
	15 - 15,5 - 17 HP B&S	005a	005a	005a	005a	-	005a
	18 - 20 HP B&S	-	005b	-	-	005b	-
	13 HP TECUMSEH	005c	-	005c	-	-	-
	15 HP TECUMSEH	005d	-	005d	-	-	-
	TRASMISSIONE TRANSMISSION TRANSMISSION GETRIEBE	006	006	006	006	006	006
	SOLLEVAMENTO PIATTO DI TAGLIO CUTTING PLATE LIFTING SOULEVEMENT PLATEAU DE COUPE SCHNEIDWERKZEUG AUFHEBESATZ	007	007	007	007	007	007
	PIATTO DI TAGLIO (1) CUTTING PLATE (1) PLATEAU DE COUPE (1) SCHNEIDWERKZEUG (1)	008	008	008	008	008	008
	PIATTO DI TAGLIO (2) CUTTING PLATE (2) PLATEAU DE COUPE (2) SCHNEIDWERKZEUG (2)	009	009	009	009	009	009

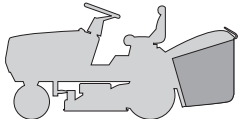
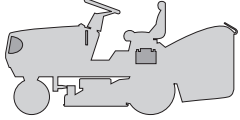
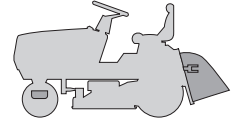
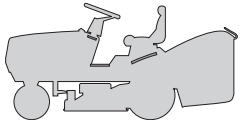

GRUPPO / UNIT / GROUPE / GRUPPE	TC102 hydro	TCP102 hydro	TCR102 hydro	TC122 hydro	TCP122 hydro	TCR122 hydro
 <p>SACCO GRASSCATCHER BAC AUFFANGSACK</p>	010	010	010	010	010	010
 <p>PARTI ELETTRICHE ELECTRICAL PARTS PARTIES ELECTRIQUES ELETRISCHETEILE</p>	011	011	011	011	011	011
 <p>ACCESSORI A RICHIESTA OPTIONALS ON REQUEST ACCESSOIRES SUR DEMANDE ZUBEHOERE NACH ANFRAGE</p>	012	012	012	012	012	012
 <p>ETICHETTE LABELS ETIQUETTES KLEBZETTEL</p>	013	013	013	013	013	013
<p>SCHEMA ELETTRICO WIRE DIAGRAM SCHEMA ELECTRIQUE ELEKTRISCHES SCHEMA</p>						
12 - 12,5 - 13 HP B&S - 13 - 15 HP TECUMSEH	014	-	014	-	-	-
15 - 15,5 - 17 HP B&S	014a	014a	014a	014a	-	014a
18 - 20 HP B&S (with lever)	-	014b	-	-	014b	-
18 - 20 HP B&S (with clutch)	-	014c	-	-	014c	-

www.emc-motoculture.com

TC102 hy. TCP102 hy. TCR102 hy.

TC122 hy. TCP122 hy. TCR122 hy.

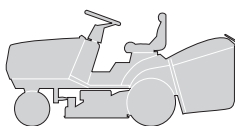

**ELENCO NUMERICO
NUMERICAL LIST
LISTE NUMERIQUE
NUMERISCHE AUFSTELLUNG**

2000

000.0

5 / 8

CODE	TABLE	N.	Q.TY	CODE	TABLE	N.	Q.TY	CODE	TABLE	N.	Q.TY
12001000/0	003	4	2	12293201/0	006	51	1	12540260/0	005c	9	2
12001000/0	003	46	1	12293201/0	007	19	2	12543000/0	006	3	1
12001000/0	003	67	2	12293201/0	008	3	4	12543000/0	007	65	2
12001010/0	006	78	2	12293201/0	008	73	2	12581200/0	002	43	2
12139100/0	009	19	2	12295200/0	001	4	2	12581200/0	002a	43	2
12139480/0	008	22	3	12295200/0	003	18	2	12581200/0	002b	43	2
12154210/0	009	17	6	12295200/0	003	34	1	12582100/0	005b	21	5
12154320/0	002	27	2	12295200/0	004	9	1	12582101/0	002	85	2
12154320/0	002a	27	2	12295200/0	004	52	2	12582101/0	002a	85	2
12154320/0	002b	27	2	12295200/0	007	39	2	12582101/0	002b	85	2
12154330/0	001	85	3	12295200/0	007	60	4	12582101/0	010	10	2
12154330/0	001	105	2	12295800/0	003	51	1	12583500/0	002	53	4
12154330/0	001	108	2	12360352/0	011	15	2	12583500/0	002a	53	4
12154330/0	008	39	2	12360420/0	001	21	2	12583500/0	002b	53	4
12154510/0	001	13	4	12360425/0	001	111	2	12583500/0	005a	13	2
12154510/0	004	24	2	12361005/0	011	26	1	12583500/0	005a	33	2
12154510/0	004	55	1	12369500/0	006	54	1	12583500/0	005a	38	2
12154510/0	004	59	1	12379511/0	003	37	2	12583500/0	005b	16	4
12154510/0	008	82	1	12400030/0	010	34	1	12583500/0	005b	33	2
12154510/0	010	15	1	12436030/0	003	15	1	12583500/0	005b	38	2
12154510/0	012	6	2	12436030/0	009	7	4	12583500/0	005c	13	2
12155000/0	003	45	1	12436050/0	002	4	2	12583500/0	005c	33	2
12155000/0	004	12	1	12436050/0	002a	4	2	12583500/0	005c	38	2
12155000/0	004	16	1	12436050/0	002b	4	2	12583500/0	005d	11	2
12155000/0	004	28	1	12436050/0	007	55	4	12583500/0	005d	33	2
12155000/0	006	8	1	12436050/0	007	55	6	12583500/0	005d	38	2
12155000/0	006	12	1	12500030/0	009	4	2	12583500/0	008	12	2
12155000/0	006	20	2	12521300/0	001	32	2	12583500/0	008	25	1
12155000/0	006	27	2	12521310/0	002	44	2	12583500/0	008	34	1
12155000/0	006	44	4	12521310/0	002a	44	2	12583500/0	008	47	1
12155000/0	006	48	1	12521310/0	002b	44	2	12583501/0	004	49	1
12155000/0	006	56	1	12521330/0	001	63	4	12585100/0	001	3	2
12155000/0	007	37	2	12521331/0	002	86	6	12587900/0	003	50	1
12155000/0	007	44	4	12521331/0	002a	86	6	12604896/0	006	58	1
12155000/0	007	47	2	12521331/0	002b	86	6	12604897/0	001	92	2
12155000/0	008	18	4	12521350/0	004	11	1	12604899/0	007	9	1
12155000/0	008	44	1	12521350/0	004	15	1	12609200/0	008	8	2
12155000/0	008	79	1	12521350/0	006	43	4	12609255/0	007	49	2
12155000/0	012	24	3	12521350/0	006	47	2	12609260/0	004	47	2
12155010/0	001	87	2	12521350/0	007	36	2	12609260/0	007	15	1
12155010/0	005b	10	1	12521350/0	007	46	2	12609260/0	009	15	2
12155010/0	008	84	1	12521350/0	007	54	2	12610800/0	008	7	2
12156602/0	003	2	2	12521350/0	008	11	2	12620206/0	007	16	2
12156602/0	003	24	1	12521350/0	008	17	5	12620299/0	002	32	1
12156602/0	003	27	1	12521350/0	008	86	1	12620299/0	002a	32	1
12156602/0	003	33	1	12521360/0	003	23	1	12620299/0	002b	32	1
12156602/0	007	40	2	12521360/0	004	8	2	12622650/0	003	13	1
12156602/0	007	42	2	12521360/0	004	53	1	12674701/0	002	83	2
12156602/0	007	58	2	12521370/0	003	14	1	12674701/0	002a	83	2
12290791/0	001	33	2	12521390/0	003	49	2	12674701/0	002b	83	2
12290800/0	002	47	1	12521410/0	007	14	1	12689515/0	005b	19	1
12290800/0	002a	47	1	12523020/0	002	26	2	12689515/0	012	5	2
12290800/0	002b	47	1	12523020/0	002a	26	2	12691100/0	001	6	1
12292100/0	010	11	2	12523020/0	002b	26	2	12691100/0	005a	8	4
12292102/0	001	16	4	12523040/0	001	12	4	12691100/0	005b	11	3
12292102/0	001	19	4	12523040/0	004	23	1	12691100/0	005c	8	4
12292102/0	001	24	4	12523040/0	004	54	1	12691100/0	006	24	1
12292102/0	001	26	2	12523040/0	004	58	1	12691115/0	005	9	4
12292102/0	008	28	3	12523060/0	001	53	6	12691115/0	005b	8	1
12292102/0	010	24	2	12523060/0	001	76	2	12691200/0	006	46	1
12293200/0	004	57	2	12523060/0	001	110	2	12691200/0	008	16	3
12293200/0	005	11	1	12523060/0	006	11	1	12691400/0	006	25	1
12293200/0	005a	10	1	12523060/0	006	19	1	12691700/0	003	44	1
12293200/0	005c	10	1	12523060/0	006	26	2	12691700/0	007	35	2
12293200/0	006	14	2	12523060/0	008	43	1	12691700/0	008	15	1
12293200/0	008	20	1	12523060/0	008	83	1	12691800/0	006	42	4
12293201/0	001	8	3	12523070/0	001	75	2	12692000/0	006	6	1
12293201/0	001	54	4	12523070/0	008	46	1	12692050/0	008	78	1
12293201/0	001	64	4	12523080/0	009	23	2	12694100/0	003	48	1
12293201/0	001	74	2	12523090/0	003	26	1	12726388/0	002	46	1
12293201/0	001	79	2	12523100/0	007	62	2	12726388/0	002a	46	1
12293201/0	005	12	3	12540260/0	005	10	2	12726388/0	002b	46	1
12293201/0	005a	11	3	12540260/0	005	33	1	12728099/0	002a	20	2
12293201/0	005b	12	3	12540260/0	005a	9	2	12728440/0	002	15	2
12293201/0	005c	11	3	12540260/0	005b	9	2	12728440/0	002	17	4



CODE	TABLE	N.	Q.TY	CODE	TABLE	N.	Q.TY	CODE	TABLE	N.	Q.TY
12728440/0	002	20	2	12792611/0	005d	37	2	18738202/0	005b	13	1
12728440/0	002a	15	2	12792611/0	006	50	1	18738203/0	005b	14	1
12728440/0	002a	17	4	12792611/0	007	18	2	18738206/0	005a	12	1
12728440/0	002b	15	2	12792611/0	008	2	4	18738211/0	005c	12	1
12728440/0	002b	17	4	12792611/0	008	72	2	18738212/0	005d	10	1
12728440/0	002b	20	2	12793101/0	002	52	4	19035000/0	009	3	2
12728450/0	010	38	2	12793101/0	002a	52	4	19216032/0	009	13	4
12728510/0	010	35	2	12793101/0	002b	52	4	19216033/1	008	6	2
12729601/0	002	84	4	12793101/0	005b	15	4	19410603/1	011	24	1
12729601/0	002a	84	4	12793102/0	001	7	1	19410605/1	011	23	1
12729601/0	002b	84	4	12793102/0	005a	32	1	19410606/0	011	22	2
12729601/0	010	9	4	12793102/0	005b	32	2	19410606/0	011	22	3
12731350/0	001	65	4	12793102/0	005c	32	2	19410609/0	011	25	1
12731580/0	001	35	1	12793102/0	005d	32	2	22034523/0	007	11	3
12731580/0	001	46	4	12793102/0	006	53	1	22061337/0	008	80	1
12731601/0	004	4	4	12793102/0	008	10	2	22110230/0	003	68	2
12734995/0	001	43	4	12793102/0	008	23	1	22110230/0	006	79	2
12734995/0	005d	42	1	12793102/0	008	32	1	22160400/0	003	22	1
12735104/0	005	34	1	12793102/0	008	45	1	22160400/0	009	22	2
12735105/0	011	2	3	12793900/0	008	19	1	22524970/1	001	86	2
12735106/0	005	14	4	12794980/0	007	59	2	22524970/1	004	26	1
12735106/0	005a	40	4	12815200/0	008	27	3	22672150/0	003	25	1
12735106/0	005b	40	4	12815210/0	004	22	4	22672151/0	008	74	1
12735106/0	005c	40	4	12815245/0	001	11	4	22672153/0	004	46	2
12735106/0	005c	42	2	12818700/0	009	16	6	22672153/0	007	13	1
12735106/0	005d	40	4	12818900/0	008	42	1	22746600/0	003	32	2
12735108/0	005d	8	1	14356177/2	013	3	1	22746600/0	003	41	2
12735109/0	005d	9	3	14356754/1	013	2	1	24487998/0	007	63	2
12735110/0	001	29	2	14357184/2	013	4	1	24487998/0	012	8	2
12735110/0	002	14	6	14357190/0	013	1	1	24487999/0	012	9	1
12735110/0	002a	14	6	14357423/1	013	9	1	24487999/0	012	46	2
12735110/0	002b	14	6	14357526/0	013	8	1	25020800/1	009	10	1
12735110/0	008	30	6	14357905/0	013	7	1	25020801/2	009	11	1
12735120/0	001	101	1	14357906/0	013	5	1	25032001/1	010	3	1
12735120/0	006	49	1	14357967/0	013	6	1	25032002/1	010	4	1
12735402/0	002	72	4	18120002/1	011	7	1	25033002/0	007	6	1
12735402/0	002a	72	4	18210016/0	011	12	1	25033003/1	003	31	1
12735402/0	002b	72	4	18230000/0	011	28	1	25033029/0	007	50	2
12735402/0	008	62	3	18310005/0	005a	39	1	25033031/0	004	50	1
12735510/0	005	32	1	18310005/0	005b	39	1	25033033/0	006	57	1
12735530/0	005a	14	2	18310005/0	005c	39	1	25033034/0	004	29	1
12735530/0	005c	14	2	18310005/0	005d	39	1	25033060/0	009	2	2
12735530/0	005d	12	2	18375051/1	005	4	3	25034002/1	003	36	4
12735597/0	001	31	2	18375051/1	005a	3	1	25034523/0	004	45	2
12735599/0	005a	35	4	18375051/1	005b	3	1	25038000/0	008	14	4
12735599/0	005b	35	4	18375051/1	005c	3	1	25038002/1	006	7	2
12735599/0	005c	35	4	18375051/1	005d	3	1	25040601/0	003	2	2
12735599/0	005d	35	4	18375053/0	005	5	1	25040602/0	003	5	2
12735694/0	009	24	1	18375053/0	005a	4	1	25040605/0	007	33	4
12735695/1	009	25	1	18375053/0	005b	4	1	25040617/0	003	16	1
12737310/0	006	2	1	18375053/0	005c	4	1	25060100/2	008	29	1
12737320/0	006	2	1	18375053/0	005d	4	1	25060101/1	008	29	1
12760520/0	012	23	3	18399060/0	006	30	1	25065002/0	011	16	1
12760600/0	004	48	1	18400861/0	011	10	1	25065003/0	011	17	1
12771400/0	008	38	2	18400950/0	006	41	1	25076802/0	002	6	1
12788512/0	002	42	2	18401001/0	005	8	1	25076808/0	002a	7	1
12788512/0	002a	42	2	18401001/0	005a	7	1	25090000/0	002	48	1
12788512/0	002b	42	2	18401001/0	005b	7	1	25090000/0	002a	48	1
12788910/0	001	107	2	18401001/0	005c	7	1	25090000/0	002b	48	1
12788910/0	002	25	2	18401001/0	005d	7	1	25108009/0	009	31	1
12788910/0	002a	25	2	18450060/1	011	8	1	25109521/0	006	28	2
12788910/0	002b	25	2	18450065/1	011	9	1	25110219/0	002	61	1
12789000/0	001	84	3	18450067/0	011	27	1	25110219/0	002b	61	1
12789000/0	001	104	2	18459100/0	011	21	2	25110233/0	002	71	1
12791011/0	001	15	4	18564861/0	011	32	1	25110233/0	002a	71	1
12791011/0	001	18	4	18564862/0	011	33	1	25110233/0	002b	71	1
12791011/0	001	23	4	18565351/0	011	11	1	25110234/0	002	71	1
12791200/0	010	23	2	18566110/0	001	42	2	25110234/0	002a	71	1
12791213/0	005b	20	1	18566110/0	012	4	2	25110234/0	002b	71	1
12791213/0	008	81	1	18716131/1	005b	34	1	25110235/0	002	71	1
12791213/0	011	14	2	18716132/0	005a	34	1	25110235/0	002a	71	1
12791400/0	005b	18	3	18716132/0	005c	34	1	25110235/0	002b	71	1
12792099/0	010	8	2	18716132/0	005d	34	1	25110236/0	002	71	1
12792099/0	010	14	1	18736111/0	011	13	1	25110236/0	002a	71	1
12792610/0	005b	37	2	18737849/0	005	7	1	25110236/0	002b	71	1
12792611/0	001	52	6	18737849/0	005a	6	1	25110239/0	002	61	1
12792611/0	001	62	4	18737849/0	005b	6	1	25110239/0	002a	61	1
12792611/0	001	78	2	18737849/0	005c	6	1	25110239/0	002b	61	1
12792611/0	005a	37	2	18737849/0	005d	6	1	25110240/0	002	61	1
12792611/0	005c	37	2	18737950/0	012	51	1	25110240/0	002a	61	1



CODE	TABLE	N.	Q.TY	CODE	TABLE	N.	Q.TY	CODE	TABLE	N.	Q.TY
25110240/0	002b	61	1	25430218/0	007	64	1	25598050/0	005d	5	1
25110241/0	002	61	1	25430219/0	006	15	1	25600009/0	002	21	1
25110241/0	002a	61	1	25430220/0	008	49	1	25600009/0	002a	21	1
25110241/0	002b	61	1	25430223/0	001	83	1	25600009/0	002b	21	1
25110242/0	002	61	1	25430224/0	001	82	1	25600031/0	005c	41	1
25110242/0	002a	61	1	25430227/0	008	77	1	25600038/0	005d	41	1
25110242/0	002b	61	1	25430230/0	011	8	1	25600041/0	010	31	1
25110245/0	002a	71	1	25430235/0	001	102	1	25600042/0	010	32	1
25110246/0	002a	71	1	25430236/0	004	7	1	25600047/0	010	36	1
25110247/0	002a	71	1	25463200/0	009	18	2	25600048/0	010	37	1
25110248/0	002a	71	1	25470901/0	007	4	1	25600049/0	008	61	1
25110249/0	002	71	1	25485001/0	002b	5	1	25600050/0	008	61	1
25110249/0	002b	71	1	25486020/0	001	106	1	25600051/0	002	22	1
25110260/0	002	64	1	25510000/0	001	90	1	25600051/0	002a	22	1
25110260/10	002a	64	1	25510006/0	009	6	4	25600051/0	002b	22	1
25110260/10	002b	64	1	25510011/0	007	5	1	25601549/0	008	31	1
25110265/0	004	42	1	25510021/0	012	45	1	25601550/0	008	31	1
25110266/0	004	43	1	25510022/0	012	7	2	25601554/0	006	10	1
25110267/0	004	2	1	25510023/1	002	3	2	25601555/0	006	17	1
25110270/0	002	63	1	25510023/1	002a	3	2	25601555/0	008	40	1
25110270/0	002a	63	1	25510023/1	002b	3	2	25601558/1	006	21	2
25110270/0	002b	63	1	25510036/0	006	18	1	25601559/1	008	5	2
25120152/0	002	16	1	25510043/0	003	17	1	25601560/0	008	21	2
25120152/0	002b	16	1	25510048/0	007	53	2	25601561/0	008	5	2
25120153/0	002a	16	1	25510051/0	007	61	2	25601562/0	008	21	2
25120171/0	002a	16	1	25510051/0	009	32	2	25601566/0	006	1	1
25122000/0	002a	18	2	25510052/0	004	6	1	25601568/0	006	1	1
25122000/1	001	72	2	25510053/0	007	52	2	25605000/1	007	3	1
25122200/1	003	63	4	25510053/0	007	52	6	25650037/0	008	9	1
25160002/0	008	35	1	25510054/0	004	51	1	25650065/0	001	17	2
25160003/0	008	13	4	25510054/0	004	56	1	25650067/0	001	20	1
25160005/0	003	47	1	25510055/0	007	45	2	25670005/1	003	66	2
25160007/0	008	41	1	25510056/0	007	56	2	25670005/1	006	75	2
25160018/0	006	22	1	25510076/0	007	38	2	25670006/0	003	3	2
25160021/0	006	29	1	25519997/0	012	22	1	25670007/0	008	24	1
25160023/0	006	76	2	25520002/1	003	11	1	25670007/0	008	33	1
25160024/0	006	23	1	25547014/0	002	2	1	25670008/0	007	41	4
25160025/0	007	12	1	25547014/0	002	82	1	25670008/0	007	57	4
25160027/0	006	9	1	25547014/0	002b	2	1	25670011/0	004	27	1
25160501/0	009	14	2	25547014/0	002b	82	1	25670011/0	006	55	1
25207000/1	008	37	1	25547015/0	002	2	1	25670011/0	007	51	6
25207200/0	009	12	2	25547015/0	002	82	1	25670012/0	003	19	2
25253001/0	004	25	1	25547015/0	002b	2	1	25670014/0	003	21	1
25260000/0	002	18	2	25547015/0	002b	82	1	25670017/0	006	77	2
25260000/0	002b	18	2	25547016/1	002	2	1	25722450/0	002	51	1
25290000/0	002	28	1	25547016/1	002	82	1	25722450/0	002b	51	1
25290000/0	002a	28	1	25547016/1	002b	2	1	25722451/1	002a	51	1
25290000/0	002b	28	1	25547016/1	002b	82	1	25735110/2	002	23	1
25318109/0	001	89	1	25547024/0	002	2	1	25735110/2	002a	23	1
25318115/1	008	36	1	25547024/0	002	82	1	25735110/2	002b	23	1
25318119/0	008	36	1	25547024/0	002b	2	1	25735111/2	002	23	1
25318124/0	010	33	1	25547024/0	002b	82	1	25735111/2	002a	23	1
25318153/0	007	48	2	25547025/0	002a	2	1	25735111/2	002b	23	1
25318157/0	006	52	1	25547025/0	002a	82	1	25735506/1	007	17	1
25318161/0	007	34	2	25547026/0	002a	2	1	25735507/0	003	20	1
25394501/0	002	45	1	25547026/0	002a	82	1	25755016/0	001	103	1
25394501/0	002a	45	1	25547027/0	002a	2	1	25774213/0	012	43	1
25394501/0	002b	45	1	25547027/0	002a	82	1	25774220/0	010	22	2
25394503/1	008	87	1	25547028/0	002a	2	1	25774273/0	001	5	2
25394504/0	007	7	1	25547028/0	002a	82	1	25774275/0	004	10	1
25394508/0	010	13	1	25547081/0	004	3	1	25785095/0	005b	17	1
25394509/0	004	30	1	25547089/0	001	44	1	25785133/0	001	14	1
25410858/0	002	5	1	25547091/0	001	45	1	25785137/0	001	22	1
25410860/0	002a	5	1	25547093/0	002	2	1	25785141/0	001	28	1
25410861/0	002a	6	1	25547093/0	002	82	1	25785143/0	004	21	1
25410865/0	002b	6	1	25547093/0	002b	82	1	25795000/0	002	24	1
25420004/0	011	4	1	25570000/0	003	12	1	25795000/0	002a	24	1
25420005/0	011	4	1	25580014/0	001	109	2	25795000/0	002b	24	1
25430202/0	001	91	1	25580019/0	001	25	1	25840001/0	003	40	1
25430203/0	001	81	1	25580020/0	002	62	1	25840010/0	006	13	1
25430205/0	001	71	2	25580020/0	002a	62	1	25869006/0	005	2	1
25430208/0	007	8	1	25580020/0	002b	62	1	25869016/0	005	3	1
25430209/0	003	72	8	25590000/0	003	64	2	25869016/0	005a	2	1
25430210/0	006	31	1	25590001/0	006	73	2	25869017/0	005b	2	1
25430210/0	008	49	1	25590002/0	003	64	2	25869027/0	005c	2	1
25430210/0	010	25	1	25590003/0	006	73	2	25869027/0	005d	2	1
25430213/0	004	31	1	25598050/0	005	6	1	25869029/1	010	12	1
25430215/0	002	19	2	25598050/0	005a	5	1	25869043/0	012	3	1
25430215/0	002b	19	2	25598050/0	005b	5	1	25943001/0	001	73	2
25430217/0	002a	19	2	25598050/0	005c	5	1	25950000/0	006	74	2



CODE	TABLE	N.	Q.TY	CODE	TABLE	N.	Q.TY	CODE	TABLE	N.	Q.TY
25950002/0	003	65	2	82110250/1	003	71	2				
25961200/0	002	31	1	82110251/1	006	81	2				
25961200/0	002a	31	1	82110252/0	003	71	2				
25961200/0	002b	31	1	82110253/0	006	81	2				
27275000/0	001	27	1	82207200/1	009	8	1				
27430554/0	001	34	1	82207201/2	009	9	1				
27430557/0	006	16	1	82230348/0	003	39	1				
27522412/0	011	1	1	82230349/0	003	38	1				
27522413/0	011	1	1	82300002/0	007	1	1				
27546019/0	001	30	1	82318101/0	003	43	1				
33320504/0	011	30	1	82318139/0	007	2	1				
33320505/0	011	31	1	82318155/0	007	31	1				
33320506/0	011	29	1	82318157/0	007	32	1				
33340033/0	011	3	1	82318159/0	007	31	1				
33500030/0	011	20	2	82318161/0	007	32	1				
35062001/0	006	4	1	82318162/0	008	76	1				
35062811/0	008	48	1	82318165/0	006	5	1				
35062812/0	008	48	1	82394001/1	010	5	1				
35062813/0	008	48	1	82400003/0	012	2	1				
35062814/0	008	48	1	82500011/1	004	1	1				
35065600/0	008	26	1	82500013/0	004	41	1				
35065601/0	008	26	1	82510041/0	001	9	1				
82000200/1	002	41	1	82510043/0	001	10	1				
82000200/1	002a	41	1	82547003/2	008	1	1				
82000200/1	002b	41	1	82547005/1	008	1	1				
82000201/1	002	41	1	82547011/1	001	2	1				
82000201/1	002a	41	1	82565010/0	009	1	1				
82000201/1	002b	41	1	82565011/0	009	1	1				
82000477/0	007	43	2	82565015/0	009	-	1				
82000479/0	007	10	1	82565016/0	009	-	1				
82000481/0	004	44	1	82565020/0	009	-	1				
82000483/0	010	21	1	82565021/0	009	-	1				
82000487/0	004	5	1	82598001/0	005	31	1				
82000590/0	003	62	2	82598005/1	005b	36	1				
82000592/0	006	72	2	82598009/1	005a	36	1				
82004340/0	009	21	1	82598017/0	005c	36	1				
82004341/0	009	20	1	82598019/0	005d	36	1				
82004342/0	009	21	1	82640001/1	005	13	1				
82004343/0	009	20	1	82650038/0	010	6	1				
82004606/0	008	85	1	82650041/0	001	61	1				
82004607/0	008	85	1	82680002/1	003	61	2				
82004608/0	008	91	1	82680003/0	006	71	2				
82004609/0	008	91	1	82680005/1	003	61	2				
82033105/0	012	44	1	82680006/0	006	71	2				
82034001/2	003	35	1	82700000/0	009	5	4				
82040058/0	011	5	1	82735502/0	012	42	1				
82040059/0	011	5	1	82774204/1	008	75	1				
82040060/0	011	6	1	82774207/0	001	77	1				
82040061/0	011	6	1	82774225/0	001	51	2				
82040063/0	011	19	1	82774227/0	008	71	1				
82040065/0	011	5	1	82785021/4	002	12	1				
82040066/0	011	6	1	82785021/4	002a	12	1				
82076801/1	002	1	1	82785021/4	002b	12	1				
82076804/0	002	1	1	82785022/4	002	11	1				
82076805/0	002	1	1	82785022/4	002a	11	1				
82076807/0	002	1	1	82785022/4	002b	11	1				
82076811/0	002b	1	1	82785023/1	002	13	1				
82076812/0	002b	1	1	82785023/1	002a	13	1				
82076813/0	002b	1	1	82785023/1	002b	13	1				
82076814/0	002b	1	1	82785084/1	008	4	1				
82076826/0	002	1	1	82785087/0	001	88	1				
82076840/0	002a	1	1	82785089/0	001	80	1				
82076842/0	002a	1	1	82785093/0	005a	31	1				
82076844/0	002a	1	1	82785093/0	005b	31	1				
82076846/0	002a	1	1	82785093/0	005c	31	1				
82106000/2	010	7	1	82785093/0	005d	31	1				
82110185/0	002a	81	1	82785109/0	006	45	1				
82110186/0	002a	81	1	82800002/1	010	2	1				
82110187/0	002a	81	1	82800039/0	001	1	1				
82110188/0	002a	81	1	82800043/0	010	1	1				
82110191/0	002	81	1	82869006/0	001	41	1				
82110191/0	002b	81	1	82869013/0	003	1	1				
82110192/0	002	81	1	99900005/0	012	41	1				
82110192/0	002b	81	1	99900015/0	012	1	1				
82110193/0	002	81	1	99900030/5	012	21	1				
82110193/0	002b	81	1								
82110194/0	002	81	1								
82110194/0	002b	81	1								
82110196/0	002	81	1								
82110196/0	002b	81	1								

www.photoculture.com

TC102 hy. TCP102 hy. TCR102 hy.

TC122 hy. TCP122 hy. TCR122 hy.

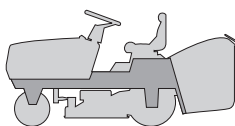

TELAIO
CHASSIS
CHASSIS
RAHMENSATZ

2000

001.0

1 / 2

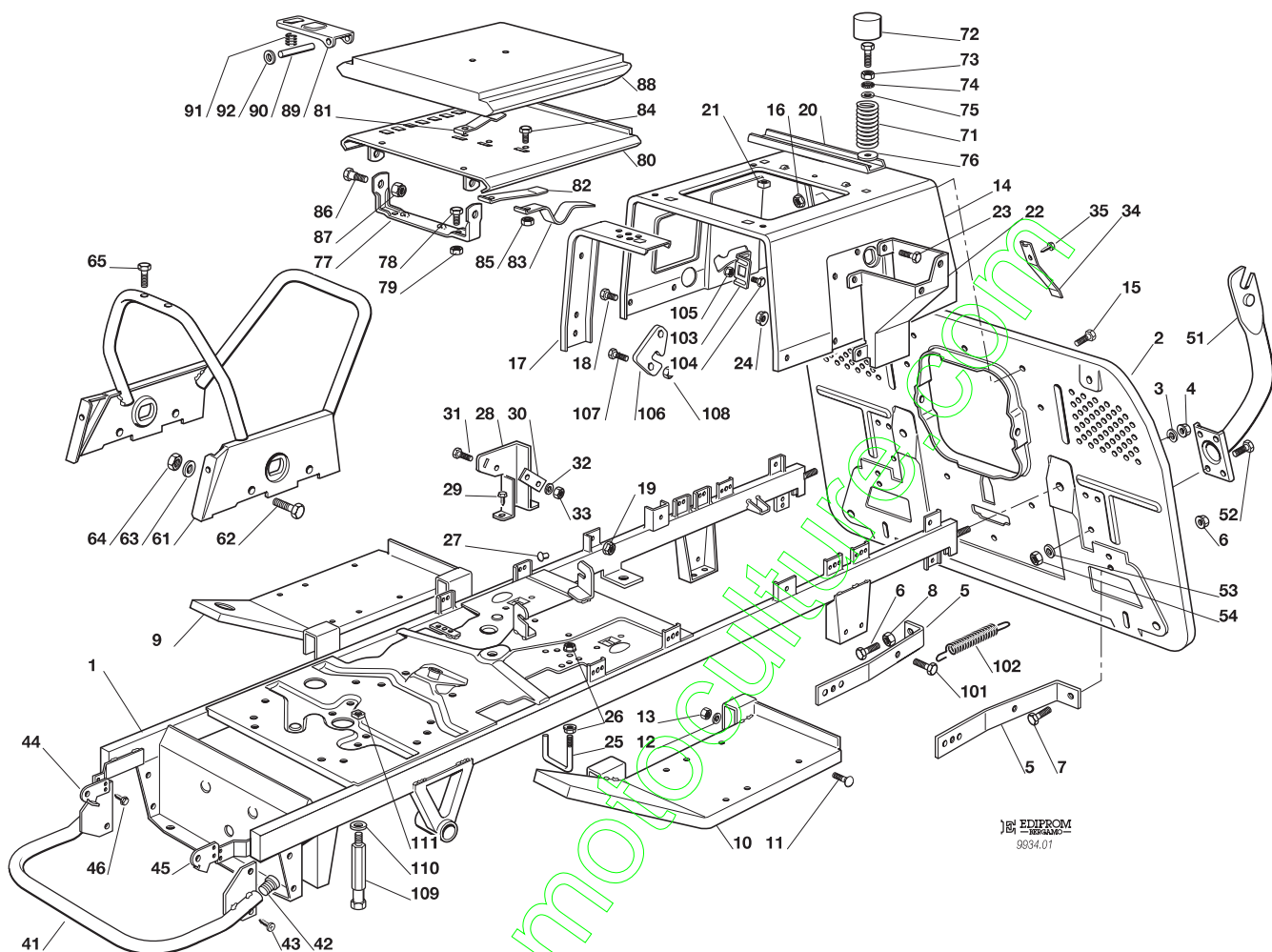

EDIPROM
9334.01

N.	CODE	Q.TY	DESCRIZIONE	DESCRIPTION	DESCRIPTION	BESCHREIBUNG
1	82800039/0	1	TELAIO	CHASSIS	CHASSIS	RAHMENSATZ
2	82547011/1	1	PIASTRA	PLATE	PLAQUE	PLATTE
3	12585100/0	2	GROWER	GROWER	GROWER	GROWER
4	12295200/0	2	DADO	NUT	ECROU	MUTTER
5	25774273/0	2	RINFORZO	STIFFENING	REINFORCEMENT	VERSTAERKUNG
6	12691100/0	1	VITE	SCREW	VIS	SCHRAUBE
7	12793102/0	1	VITE	SCREW	VIS	SCHRAUBE
8	12293201/0	3	DADO	NUT	ECROU	MUTTER
9	82510041/0	1	SUPPORTO PEDANA DESTRA	RIGHT FOOTBOARD SUPPORT	MARCHEPIED DROITE SUPPORT	RECHTE FUSSBRETTHALTER
10	82510043/0	1	SUPPORTO PEDANA SINISTRA	LEFT FOOTBOARD SUPPORT	SUPPORT MARCHEPIED GAUCHE	LINKE FUSSBRETTHALTER
11	12815245/0	4	VITE	SCREW	VIS	SCHRAUBE
12	12523040/0	4	ROSETTA	WASHER	RONDELLE	SCHEIBE
13	12154510/0	4	DADO	NUT	ECROU	MUTTER
14	25785133/0	1	SUPPORTO SEDILE	SEAT SUPPORT	SUPPORT SIEGE	SITZHALTER
15	12791011/0	4	VITE	SCREW	VIS	SCHRAUBE
16	12292102/0	4	DADO	NUT	ECROU	MUTTER
17	25650065/0	2	RINFORZO	STIFFENING	REINFORCEMENT	VERSTAERKUNG
18	12791011/0	4	VITE	SCREW	VIS	SCHRAUBE
19	12292102/0	4	DADO	NUT	ECROU	MUTTER
20	25650067/0	1	RINFORZO	STIFFENING	REINFORCEMENT	VERSTAERKUNG
21	12360420/0	2	DADO	NUT	ECROU	MUTTER
22	25785137/0	1	SUPPORTO	SUPPORT	SUPPORT	HALTER
23	12791011/0	4	VITE	SCREW	VIS	SCHRAUBE
24	12292102/0	4	DADO	NUT	ECROU	MUTTER
25	25580019/0	1	PIOLO GUIDACINGHIA	BELT GUIDE	GUIDE DE COURROIRE	RIEMENFUHRUNG
26	12292102/0	2	DADO	NUT	ECROU	MUTTER
27	27275000/0	1	GOMMINO	GROMMET	CAOUTCHOUC	GUMMI
28	25785141/0	1	SUPPORTO	SUPPORT	SUPPORT	HALTER
29	12735110/0	2	VITE	SCREW	VIS	SCHRAUBE



N.	CODE	Q.TY	DESCRIZIONE	DESCRIPTION	DESCRIPTION	BESCHREIBUNG
30	27546019/0	1	PIASTRINA	PLATE	PLAQUETTE	PLATTE
31	12735597/0	2	VITE	SCREW	VIS	SCHRAUBE
32	12521300/0	2	ROSETTA	WASHER	RONDELLE	SCHEIBE
33	12290791/0	2	DADO	NUT	ECROU	MUTTER
34	27430554/0	1	MOLLA	SPRING	RESSORT	FEDER
35	12731580/0	1	VITE	SCREW	VIS	SCHRAUBE
41	82869006/0	1	PROTEZIONE SILENZIATORE	MUFFLER PROTECTION	PROTECTION SILENCIEUX	AUSPUFFSCHUTZ
42	18566110/0	2	PUNTALE	CAP	BOUCHON	PFROPFEN
43	12734995/0	4	VITE	SCREW	VIS	SCHRAUBE
44	25547089/0	1	PIASTRINA DESTRA	RIGHT PLATE	PLAQUE DROITE	RECHTE PLATTE
45	25547091/0	1	PIASTRINA SINISTRA	LEFT PLATE	PLAQUE GAUCHE	LINKE PLATTE
46	12731580/0	4	VITE	SCREW	VIS	SCHRAUBE
51	82774225/0	2	SUPPORTO	SUPPORT	SUPPORT	HALTER
52	12792611/0	6	VITE	SCREW	VIS	SCHRAUBE
53	12523060/0	6	RONDELLA	WASHER	RONDELLE	SCHEIBE
54	12293201/0	4	DADO	NUT	ECROU	MUTTER
61	82650041/0	1	TELAIO CENTRALE	CHASSIS	CHASSIS	RAHMENSATZ
62	12792611/0	4	VITE	SCREW	VIS	SCHRAUBE
63	12521330/0	4	ROSETTA	WASHER	RONDELLE	SCHEIBE
64	12293201/0	4	DADO	NUT	ECROU	MUTTER
65	12731350/0	4	VITE	SCREW	VIS	SCHRAUBE
71	25430205/0	2	MOLLA	SPRING	RESSORT	FEDER
72	25122000/1	2	CUFFIA	HOOD	PROTECTEUR	SCHUTZKASTEN
73	25943001/0	2	VITE	SCREW	VIS	SCHRAUBE
74	12293201/0	2	DADO	NUT	ECROU	MUTTER
75	12523070/0	2	ROSETTA	WASHER	RONDELLE	SCHEIBE
76	12523060/0	2	ROSETTA	WASHER	RONDELLE	SCHEIBE
77	82774207/0	1	STAFFA SUPP. SEDILE	SEAT CLAMP SUPPORT	ETRIER SUPPORT SIEGE	BRIDE F. SITZHALTER
78	12792611/0	2	VITE	SCREW	VIS	SCHRAUBE
79	12293201/0	2	DADO	NUT	ECROU	MUTTER
80	82785089/0	1	SUPP. SEDILE FISSO	FIXED SEAT SUPP.	SUPPORT SIEGE FIXE	FEST SITZHALTER
81	25430203/0	1	MOLLA ARRESTO	SPRING	RESSORT D'ARRET	RASTFEDER
82	25430224/0	1	MOLLA COMANDO	SPRING	RESSORT DE COMMANDE	FEDER
83	25430223/0	1	MOLLA	SPRING	RESSORT	FERDER
84	12789000/0	3	VITE	SCREW	VIS	SCHRAUBE
85	12154330/0	3	DADO	NUT	ECROU	MUTTER
86	22524970/1	2	PERNO	PIN	PIVOT	BOLZEN
87	12155010/0	2	DADO	NUT	ECROU	MUTTER
88	82785087/0	1	SUPPORTO SEDILE	SEAT SUPPORT	SUPPORT SIEGE	SITZHALTER
89	25318109/0	1	LEVA ARRESTO	STOP LEVER	LEVIER D'ARRET	ABSTELLHEBEL
90	25510000/0	1	PERNO	PIN	PIVOT	BOLZEN
91	25430202/0	1	MOLLA	SPRING	RESSORT	FEDER
92	12604897/0	2	RONDELLA	WASHER	RONDELLE	SCHEIBE
			Nei modelli con innesto delle lame a leva:	For models with engagement of the blades by lever:	Dans les modèles avec embrayage des lames à levier:	Bei Modellen mit Hebelschaltung der Messer:
101	12735120/0	1	VITE	SCREW	VIS	SCHRAUBE
102	25430235/0	1	MOLLA	SPRING	RESSORT	FEDER
103	25755016/0	1	SQUADRETTA	BRACKET	EQUERRE-SUPPORT	WINKEL
104	12789000/0	2	VITE	SCREW	VIS	SCHRAUBE
105	12154330/0	2	DADO	NUT	ECROU	MUTTER
106	25486020/0	1	PATTINO	SHOE	BLOC DE GLISSEMENT	GLEITBLOCK
107	12788910/0	2	VITE	SCREW	VIS	SCHRAUBE
108	12154330/0	2	DADO	NUT	ECROU	MUTTER
109	25580014/0	2	PIOLO GUIDACINGHIA	BELT GUIDE	GUIDE DE COURROIRE	RIEMENFÜHRUNG
110	12523060/0	2	ROSETTA	WASHER	RONDELLE	SCHEIBE
111	12360425/0	2	DADO	NUT	ECROU	MUTTER

TC102 hy.

TCP102 hy.

TCR102 hy.

TC122 hy.

TCP122 hy.

TCR122 hy.

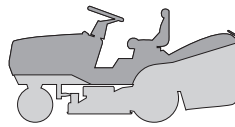

**CARROZZERIA
BODY
CARROSSERIE
KARROSSERIE**

2000

002.0

1 / 2

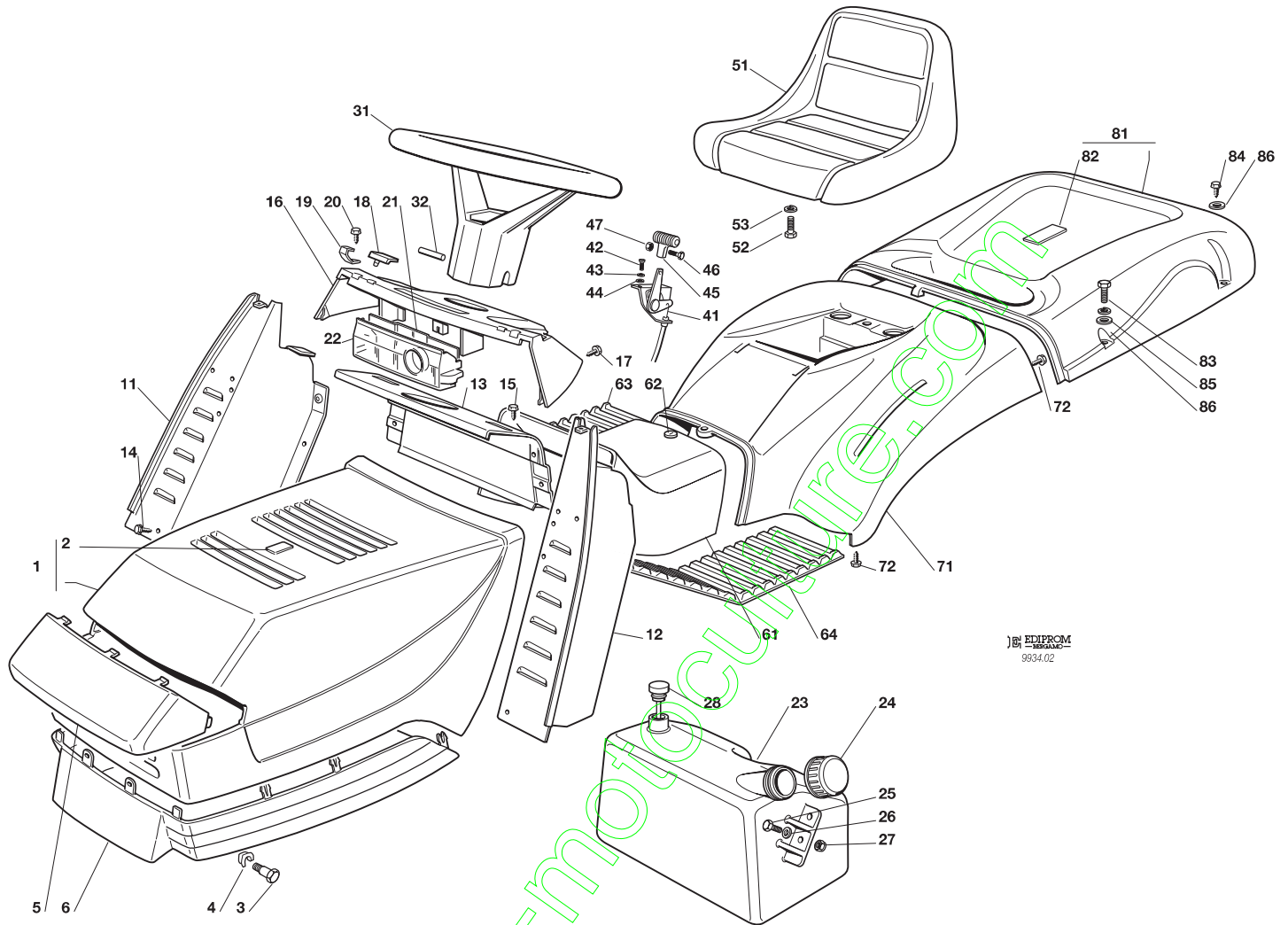

EDIPROM
9934.02

N.	CODE	Q.TY	DESCRIZIONE	DESCRIPTION	DESCRIPTION	BESCHREIBUNG
1	82076801/1	1	COFANO SUPERIORE ROSSO	UPPER ENGINE HOOD RED	CAPOT SUPERIEURE ROUGE	OBERHAUBESATZ ROT
	82076804/0		VERDE	GREEN	VERT	GRÜN
	82076805/0		GIALLO	YELLOW	JAUNE	GELB
	82076807/0		BLU	BLUE	BLEU	BLAU
	82076826/0		ARANCIONE	ORANGE	ORANGE	DUNKELORANGE
2	25547016/1	1	PIASTRINA ROSSA	PLATE RED	PLAQUE ROUGE	PLATTE ROT
	25547015/0		VERDE	GREEN	VERT	GRÜN
	25547014/0		GIALLA	YELLOW	JAUNE	GELB
	25547024/0		BLU	BLUE	BLEU	BLAU
	25547093/0		ARANCIONE	ORANGE	ORANGE	DUNKELORANGE
3	25510023/1	2	PERNO	PIN	PIVOT	BOLZEN
4	12436050/0	2	PIASTRINA	PLATE	PLAQUE	PLATTE
5	25410858/0	1	MASCHERINA	GRILL	PANNEAU	SCHUTZ
6	25076802/0	1	COFANO INFERIORE	LOWER ENGINE HOOD	CAPOT INFERIEURE	UNTERHAUBESATZ
11	82785022/4	1	SUPP. CRUSCOTTO DESTRO	RIGHT DASHBOARD SUPP.	SUPPORT TABLEAU DROITE	RECHTER KONSOLEHALTER
12	82785021/4	1	SUPP. CRUSCOTTO SIN.	LEFT DASHBOARD SUPP.	SUPPORT TABLEAU GAUCHE	LINKER KONSOLEHALTER
13	82785023/1	1	SUPP. CRUSCOTTO CENTR.	CENTRAL DASHBOARD SUPP.	SUPPORT TABLEAU CENTR.	ZENTR. KONSOLE HALTER
14	12735110/0	6	VITE	SCREW	VIS	SCHRAUBE
15	12728440/0	2	VITE	SCREW	VIS	SCHRAUBE
16	25120152/0	1	CRUSCOTTO	DASHBOARD	TABLEAU DE BORD	KONSOLE
17	12728440/0	4	VITE	SCREW	VIS	SCHRAUBE
18	25260000/0	2	GOMMINO	GROMMET	PROTECTION	SCHUTZ
19	25430215/0	2	MOLLA AGGANCIO	COUPLING SPRING	RESSORT ACCROCHAGE	KUPPLUNGSFEDER
20	12728440/0	2	VITE	SCREW	VIS	SCHRAUBE
21	25600009/0	1	PROTEZIONE SCHEDA	CARD PROTECTION	PROTECTION DE CARTE	KARTESCHUTZ
22	25600005/1/0	1	PROTEZIONE SCHEDA	CARD PROTECTION	PROTECTION DE CARTE	KARTESCHUTZ



N.	CODE	Q.TY	DESCRIZIONE	DESCRIPTION	DESCRIPTION	BESCHREIBUNG
23	25735110/2	1	SERBATOIO 12-12,5-13 -15,5 HP B&S 17 HP B&S 13 - 15 HP TECUMSEH 18 - 20 HP B&S	TANK 12-12,5-13 -15,5 HP B&S 17 HP B&S 13 - 15 HP TECUMSEH 18 - 20 HP B&S	RESERVOIR 12-12,5-13 -15,5 HP B&S 17 HP B&S 13 - 15 HP TECUMSEH 18 - 20 HP B&S	TANK 12-12,5-13 -15,5 HP B&S 17 HP B&S 13 - 15 HP TECUMSEH 18 - 20 HP B&S
24	25795000/0	1	TAPPO	CAP	BOUCHON	TANKVERSCHLUSS
25	12788910/0	2	VITE	SCREW	VIS	SCHRAUBE
26	12523020/0	2	RONDELLA	WASHER	RONDELLE	SCHEIBE
27	12154320/0	2	DADO	NUT	ECROU	MUTTER
28	25290000/0	1	INDICATORE LIVELLO 18 - 20 HP B&S	FUEL LEVEL INDICATOR 18 - 20 HP B&S	INDICATEUR NIVEAU 18 - 20 HP B&S	KRAFTSTOFFMESSER 18 - 20 HP B&S
31	25961200/0	1	VOLANTE	STEERING WHEEL	VOLANT	LENKRAD
32	12620299/0	1	SPINA	PIN	GOUPILLE	STIFT
41	82000200/1	1	ACCELERATORE 12-12,5-13 -15,5 HP B&S 17 HP B&S 13 - 15 HP TECUMSEH 18 - 20 HP B&S	ACCELERATOR 12-12,5-13 -15,5 HP B&S 17 HP B&S 13 - 15 HP TECUMSEH 18 - 20 HP B&S	ACCELERATEUR 12-12,5-13 -15,5 HP B&S 17 HP B&S 13 - 15 HP TECUMSEH 18 - 20 HP B&S	GAS ZUG 12-12,5-13 -15,5 HP B&S 17 HP B&S 13 - 15 HP TECUMSEH 18 - 20 HP B&S
42	12788512/0	2	VITE	SCREW	VIS	SCHRAUBE
43	12581200/0	2	GROWER	GROWER	GROWER	GROWER
44	12521310/0	2	RONDELLA	WASHER	RONDELLE	SCHEIBE
45	25394501/0	1	MANOPOLINA	HANDLE	POIGNE	GRIFF
46	12726388/0	1	VITE	SCREW	VIS	SCHRAUBE
47	12290800/0	1	DADO	NUT	ECROU	MUTTER
48	25090000/0	1	COMANDO STARTER 18 - 20 HP B&S	STARTER DRIVE 18 - 20 HP B&S	COMMANDE STARTER 18 - 20 HP B&S	STARTER BETAETIGUNG 18 - 20 HP B&S
51	25722450/0	1	SEDILE	SEAT	SIEGE	SITZ
52	12793101/0	4	VITE	SCREW	VIS	SCHRAUBE
53	12583500/0	4	GROWER	GROWER	GROWER	GROWER
61	25110239/0	1	COPERTURA CENTRALE ROSSO	COVER RED	COUVRE ROUGE	KAPPE ROT
	25110240/0		VERDE	GREEN	VERT	GRÜN
	25110241/0		GIALLO	YELLOW	JAUNE	GELB
	25110242/0		BLU	BLUE	BLEU	BLAU
	25110219/0		ARANCIONE	ORANGE	ORANGE	DUNKELORANGE
62	25580020/0	1	VITE	SCREW	VIS	SCHRAUBE
63	25110270/0	1	COPRIPEDANA DESTRA	RIGHT FOOTBOARD COVER	COUVRE MARCHEPIED DRO.	RECHTE FUSSBRETTDECKEL
64	25110260/0	1	COPRIPEDANA SINISTRA	LEFT FOOTBOARD COVER	COUVRE MARCHEPIED GAU.	LINKE FUSSBRETTDECKEL
71	25110233/0	1	COPERTURA RUOTE ROSSO	WHEELS COVER RED	COUVRE-ROUES ROUGE	RADENKAPPE ROT
	25110234/0		VERDE	GREEN	VERT	GRÜN
	25110235/0		GIALLO	YELLOW	JAUNE	GELB
	25110236/0		BLU	BLUE	BLEU	BLAU
	25110249/0		ARANCIONE	ORANGE	ORANGE	DUNKELORANGE
72	12735402/0	4	VITE	SCREW	VIS	SCHRAUBE
81	82110191/0	1	COPERTURA SACCO ROSSO	GRASS-CATCHER COVER RED	COUVRE-BAC ROUGE	SACKKAPPE ROT
	82110192/0		VERDE	GREEN	VERT	GRÜN
	82110193/0		GIALLO	YELLOW	JAUNE	GELB
	82110194/0		BLU	BLUE	BLEU	BLAU
	82110196/0		ARANCIONE	ORANGE	ORANGE	DUNKELORANGE
82	25547016/1	1	PIASTRINA ROSSA	PLATE RED	PLAQUE ROUGE	PLATTE ROT
	25547015/0		VERDE	GREEN	VERT	GRÜN
	25547014/0		GIALLA	YELLOW	JAUNE	GELB
	25547024/0		BLU	BLUE	BLEU	BLAU
	25547093/0		ARANCIONE	ORANGE	ORANGE	DUNKELORANGE
83	12674701/0	2	VITE	SCREW	VIS	SCHRAUBE
84	12729601/0	4	VITE	SCREW	VIS	SCHRAUBE
85	12582101/0	2	GROWER	GROWER	GROWER	GROWER
86	12521331/0	6	RONDELLA	WASHER	RONDELLE	SCHEIBE

TC102 hy.	TCP102 hy.	TCR102 hy.
TC122 hy.	TCP122 hy.	TCR122 hy.

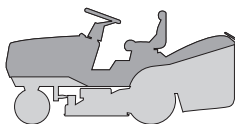

**CARROZZERIA
BODY
CARROSSERIE
KARROSSERIE**

2000
002a.0
1 / 2

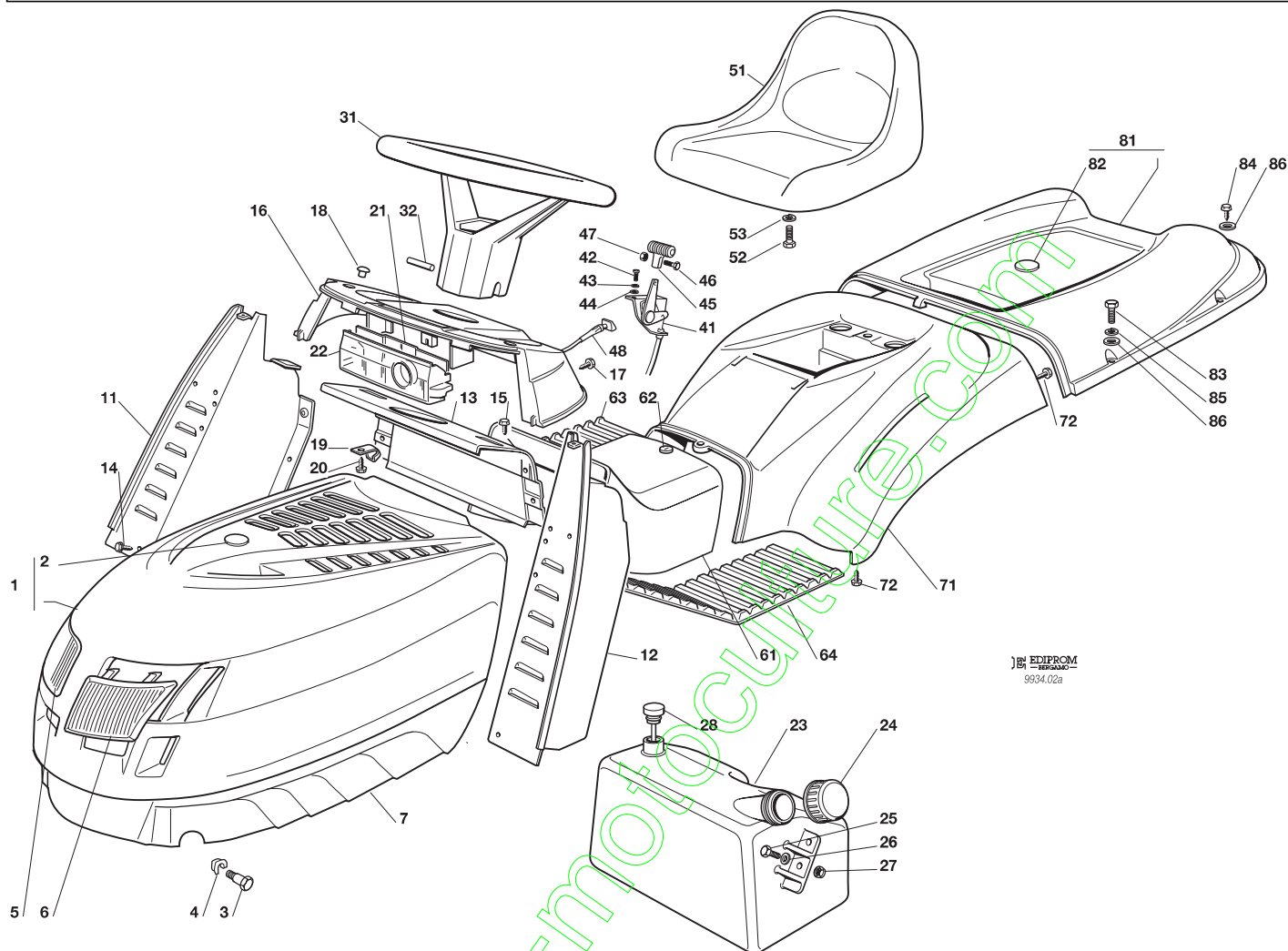

EDIPROM
9934.02a

N.	CODE	Q.TY	DESCRIZIONE	DESCRIPTION	DESCRIPTION	BESCHREIBUNG
1	82076840/0 82076842/0 82076844/0 82076846/0	1	COFANO ROSSO VERDE GIALLO BLU	ENGINE HOOD RED GREEN YELLOW BLUE	CAPOT ROUGE VERT JAUNE BLEU	HAUBESATZ ROT GRÜN GELB BLAU
2	25547025/0 25547026/0 25547027/0 25547028/0	1	PIASTRINA ROSSA VERDE GIALLA BLU	PLATE RED GREEN YELLOW BLUE	PLAQUE ROUGE VERT JAUNE BLEU	PLATTE ROT GRÜN GELB BLAU
3	25510023/1	2	PERNO	PIN	PIVOT	BOLZEN
4	12436050/0	2	PIASTRINA	PLATE	PLAQUE	PLATTE
5	25410860/0	1	MASCHERINA DESTRA	RIGHT GRILL	PANNEAU DROITE	RECHTER SCHUTZ
6	25410861/0	1	MASCHERINA SINISTRA	LEFT GRILL	PANNEAU GAUCHE	LINKER SCHUTZ
7	25076808/0	1	COFANO INFERIORE	LOWER ENGINE HOOD	CAPOT INFERIEURE	UNTERHAUBESATZ
11	82785022/4	1	SUPP. CRUSCOTTO DESTRO	RIGHT DASHBOARD SUPP.	SUPPORT TABLEAU DROITE	RECHTER KONSOLEHALTER
12	82785021/4	1	SUPP. CRUSCOTTO SIN.	LEFT DASHBOARD SUPP.	SUPPORT TABLEAU GAUCHE	LINKER KONSOLEHALTER
13	82785023/1	1	SUPP. CRUSCOTTO CENTR.	CENTRAL DASHBOARD SUPP.	SUPPORT TABLEAU CENTR.	ZENTR. KONSOLE HALTER
14	12735110/0	6	VITE	SCREW	VIS	SCHRAUBE
15	12728440/0	2	VITE	SCREW	VIS	SCHRAUBE
17	12728440/0	4	VITE	SCREW	VIS	SCHRAUBE
18	25122000/0	2	TAPPO	PLUG	BOUCHON	PROPFEN
19	25430217/0	2	MOLLA AGGANCIAMENTO	COUPLING SPRING	RESSORT ACCROCHA	GEKUPPLUNGSFEDER
20	12728099/0	2	VITE	SCREW	VIS	SCHARUBE
21	25600009/0	1	PROTEZIONE SCHEDA	CARD PROTECTION	PROTECTION DE CARTE	KARTESCHUTZ
22	256000051/0	1	PROTEZIONE SCHEDA	CARD PROTECTION	PROTECTION DE CARTE	KARTESCHUTZ
23	25735110/2	1	SERBATOIO 12-12,5-13 -15,5 HP B&S 17 HP B&S	TANK 12-12,5-13 -15,5 HP B&S 17 HP B&S	RESERVOIR 12-12,5-13 -15,5 HP B&S 17 HP B&S	TANK 12-12,5-13 -15,5 HP B&S 17 HP B&S



N.	CODE	Q.TY	DESCRIZIONE	DESCRIPTION	DESCRIPTION	BESCHREIBUNG
			13 - 15 HP TECUMSEH 18 - 20 HP B&S	13 - 15 HP TECUMSEH 18 - 20 HP B&S	13 - 15 HP TECUMSEH 18 - 20 HP B&S	13 - 15 HP TECUMSEH 18 - 20 HP B&S
24	25735111/2					
	25795000/0	1	TAPPO	CAP	BOUCHON	TANKVERSCHLUSS
25	12788910/0	2	VITE	SCREW	VIS	SCHRAUBE
26	12523020/0	2	RONDELLA	WASHER	RONDELLE	SCHEIBE
27	12154320/0	2	DADO	NUT	ECROU	MUTTER
28	25290000/0	1	INDICATORE LIVELLO 18 - 20 HP B&S	FUEL LEVEL INDICATOR 18 - 20 HP B&S	INDICATEUR NIVEAU 18 - 20 HP B&S	KRAFTSTOFFMESSER 18 - 20 HP B&S
31	25961200/0	1	VOLANTE	STEERING WHEEL	VOLANT	LENKRAD
32	12620299/0	1	SPINA	PIN	GOUPILLE	STIFT
41	82000200/1	1	ACCELERATORE 12-12,5-13 -15,5 HP B&S 17 HP B&S	ACCELERATOR 12-12,5-13 -15,5 HP B&S 17 HP B&S	ACCELERATEUR 12-12,5-13 -15,5 HP B&S 17 HP B&S	GAS ZUG 12-12,5-13 -15,5 HP B&S 17 HP B&S
	82000201/1		13 - 15 HP TECUMSEH 18 - 20 HP B&S	13 - 15 HP TECUMSEH 18 - 20 HP B&S	13 - 15 HP TECUMSEH 18 - 20 HP B&S	13 - 15 HP TECUMSEH 18 - 20 HP B&S
42	12788512/0	2	VITE	SCREW	VIS	SCHRAUBE
43	12581200/0	2	GROWER	GROWER	GROWER	GROWER
44	12521310/0	2	RONDELLA	WASHER	RONDELLE	SCHEIBE
45	25394501/0	1	MANOPOLINA	HANDLE	POIGNE	GRIF
46	12726388/0	1	VITE	SCREW	VIS	SCHRAUBE
47	12290800/0	1	DADO	NUT	ECROU	MUTTER
48	25090000/0	1	COMANDO STARTER 18 - 20 HP B&S	STARTER DRIVE 18 - 20 HP B&S	COMMANDE STARTER 18 - 20 HP B&S	STARTER BETAETIGUNG 18 - 20 HP B&S
51	25722451/1	1	SEDILE	SEAT	SIEGE	SITZ
52	12793101/0	4	VITE	SCREW	VIS	SCHRAUBE
53	12583500/0	4	GROWER	GROWER	GROWER	GROWER
61	25110239/0	1	COPERTURA CENTRALE ROSSO	COVER RED	COUVRE ROUGE	KAPPE ROT
	25110240/0		VERDE	GREEN	VERT	GRÜN
	25110241/0		GIALLO	YELLOW	JAUNE	GELB
	25110242/0		BLU	BLUE	BLEU	BLAU
62	25580020/0	1	VITE	SCREW	VIS	SCHRAUBE
63	25110270/0	1	COPRIPEDANA DESTRA	RIGHT FOOTBOARD COVER	COUVRE MARCHEPIED DRO.	RECHTE FUSSBRETTDECKEL
64	25110260/0	1	COPRIPEDANA SINISTRA	LEFT FOOTBOARD COVER	COUVRE MARCHEPIED GAU.	LINKE FUSSBRETTDECKEL
72	12735402/0	4	VITE	SCREW	VIS	SCHRAUBE
81	82110185/0	1	COPERTURA SACCO ROSSO	GRASS-CATCHER COVER RED	COUVRE-BAC ROUGE	SACKKAPPE ROT
	82110186/0		VERDE	GREEN	VERT	GRÜN
	82110187/0		GIALLO	YELLOW	JAUNE	GELB
	82110188/0		BLU	BLUE	BLEU	BLAU
82	25547025/0	1	PIASTRINA ROSSA	PLATE RED	PLAQUE ROUGE	PLATTE ROT
	25547026/0		VERDE	GREEN	VERT	GRÜN
	25547027/0		GIALLA	YELLOW	JAUNE	GELB
	25547028/0		BLU	BLUE	BLEU	BLAU
83	12674701/0	2	VITE	SCREW	VIS	SCHRAUBE
84	12729601/0	4	VITE	SCREW	VIS	SCHRAUBE
85	12582101/0	2	GROWER	GROWER	GROWER	GROWER
86	12521331/0	6	RONDELLA	WASHER	RONDELLE	SCHEIBE
			Nei modelli con innesto delle lame a leva:	For models with engagement of the blades by lever:	Dans les modèles avec embrayage des lames à levier:	Bei Modellen mit Hebelschaltung der Messer:
16	25120153/0	1	CRUSCOTTO	DASHBOARD	TABLEAU DE BORD	KONSOLE
71	25110233/0	1	COPERTURA RUOTE ROSSO	WHEELS COVER RED	COUVRE-ROUES ROUGE	RADENKAPPE ROT
	25110234/0		VERDE	GREEN	VERT	GRÜN
	25110235/0		GIALLO	YELLOW	JAUNE	GELB
	25110236/0		BLU	BLUE	BLEU	BLAU
			Nei modelli con innesto delle lame elettromagnetico:	For models with engagement of the blades by electromagnetic clutch:	Dans les modèles avec embrayage des lames électromagnétique:	Bei Modellen mit elektromagnetischer Schaltung der Messer:
16	25120171/0	1	CRUSCOTTO	DASHBOARD	TABLEAU DE BORD	KONSOLE
71	25110245/0	1	COPERTURA RUOTE ROSSO	WHEELS COVER RED	COUVRE-ROUES ROUGE	RADENKAPPE ROT
	25110246/0		VERDE	GREEN	VERT	GRÜN
	25110247/0		GIALLO	YELLOW	JAUNE	GELB
	25110248/0		BLU	BLUE	BLEU	BLAU

TC102 hy. TCP102 hy. TCR102 hy.

TC122 hy. TCP122 hy. TCR122 hy.

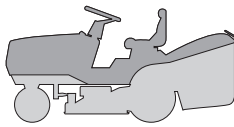

**CARROZZERIA
BODY
CARROSSERIE
KARROSSERIE**

2000

002b.0

1 / 2

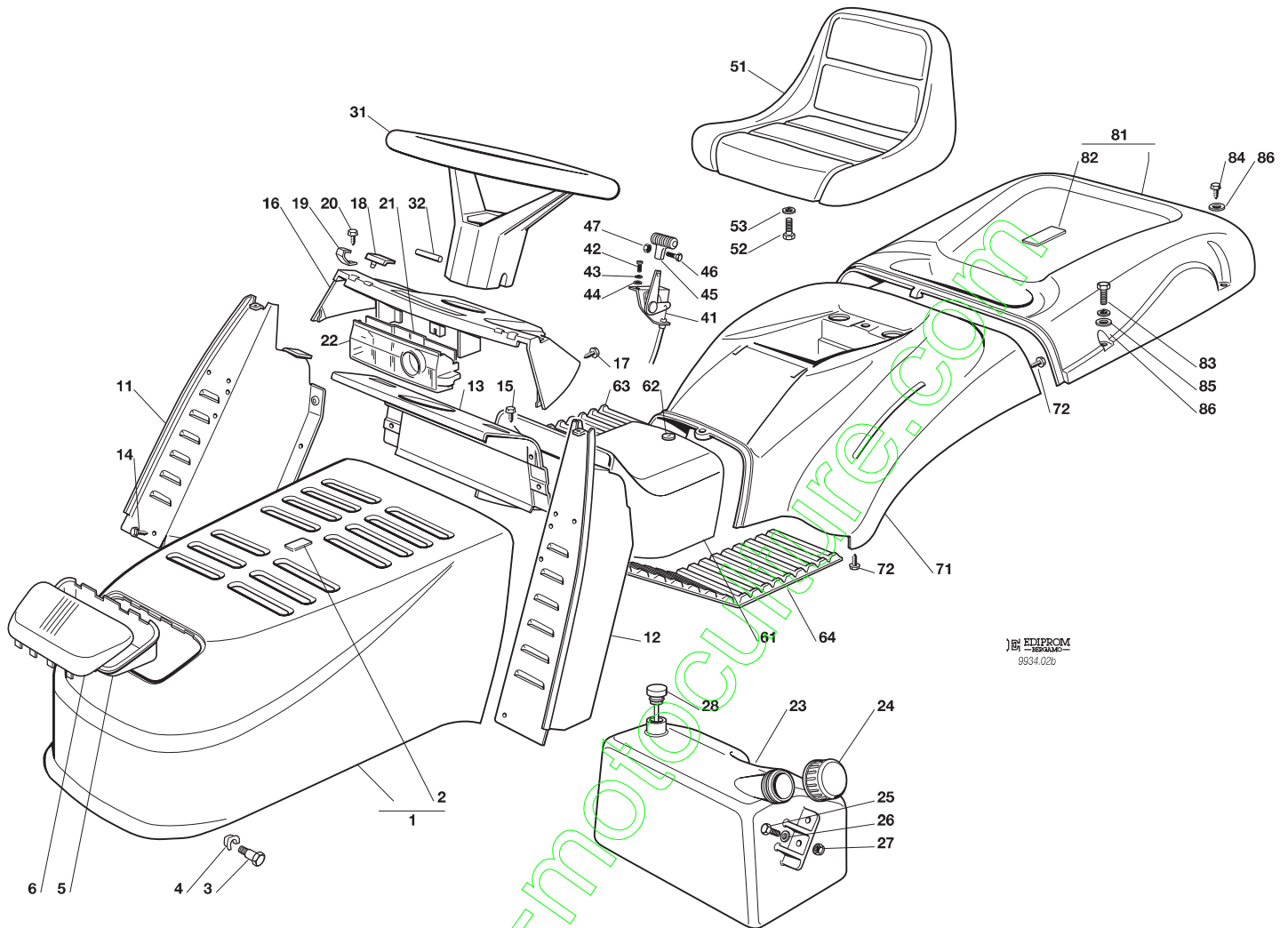

EDIPROM
9934.02b

N.	CODE	Q.TY	DESCRIZIONE	DESCRIPTION	DESCRIPTION	BESCHREIBUNG
1	82076811/0 82076812/0 82076813/0 82076814/0	1	COFANO ROSSO VERDE GIALLO BLU	ENGINE HOOD RED GREEN YELLOW BLUE	CAPOT ROUGE VERT JAUNE BLEU	HAUBESATZ ROT GRÜN GELB BLAU
2	25547016/1 25547015/0 25547014/0 25547024/0	1	PIASTRINA ROSSA VERDE GIALLA BLU	PLATE RED GREEN YELLOW BLUE	PLAQUE ROUGE VERT JAUNE BLEU	PLATTE ROT GRÜN GELB BLAU
3	25510023/1	2	PERNO	PIN	PIVOT	BOLZEN
4	12436050/0	2	PIASTRINA	PLATE	PLAQUE	PLATTE
5	25485001/0	1	PARABOLA FARI	LIGHTS PARABOLA	PARABOLE	SCHEINWERFERPARABEL
6	25410865/0	1	MASCHERINA	GRILL	PANNEAU	SCHUTZ
11	82785022/4	1	SUPP. CRUSCOTTO DESTRO	RIGHT DASHBOARD SUPP.	SUPPORT TABLEAU DROITE	RECHTER KONSOLEHALTER
12	82785021/4	1	SUPP. CRUSCOTTO SIN.	LEFT DASHBOARD SUPP.	SUPPORT TABLEAU GAUCHE	LINKER KONSOLEHALTER
13	82785023/1	1	SUPP. CRUSCOTTO CENTR.	CENTRAL DASHBOARD SUPP.	SUPPORT TABLEAU CENTR.	ZENTR. KONSOLE HALTER
14	12735110/0	6	VITE	SCREW	VIS	SCHRAUBE
15	12728440/0	2	VITE	SCREW	VIS	SCHRAUBE
16	25120152/0	1	CRUSCOTTO	DASHBOARD	TABLEAU DE BORD	KONSOLE
17	12728440/0	4	VITE	SCREW	VIS	SCHRAUBE
18	25260000/0	2	GOMMINO	GROMMET	PROTECTION	SCHUTZ
19	25430215/0	2	MOLLA AGGANCIO	COUPLING SPRING	RESSORT ACCROCHAGE	KUPPLUNGSFEDER
20	12728440/0	2	VITE	SCREW	VIS	SCHRAUBE
21	25600009/0	1	PROTEZIONE SCHEDA	CARD PROTECTION	PROTECTION DE CARTE	KARTESCHUTZ
22	25600005/1/0	1	PROTEZIONE SCHEDA	CARD PROTECTION	PROTECTION DE CARTE	KARTESCHUTZ



N.	CODE	Q.TY	DESCRIZIONE	DESCRIPTION	DESCRIPTION	BESCHREIBUNG
23	25735110/2	1	SERBATOIO 12-12,5-13 -15,5 HP B&S 17 HP B&S 13 - 15 HP TECUMSEH 18 - 20 HP B&S	TANK 12-12,5-13 -15,5 HP B&S 17 HP B&S 13 - 15 HP TECUMSEH 18 - 20 HP B&S	RESERVOIR 12-12,5-13 -15,5 HP B&S 17 HP B&S 13 - 15 HP TECUMSEH 18 - 20 HP B&S	TANK 12-12,5-13 -15,5 HP B&S 17 HP B&S 13 - 15 HP TECUMSEH 18 - 20 HP B&S
24	25795000/0	1	TAPPO	CAP	BOUCHON	TANKVERSCHLUSS
25	12788910/0	2	VITE	SCREW	VIS	SCHRAUBE
26	12523020/0	2	RONDELLA	WASHER	RONDELLE	SCHEIBE
27	12154320/0	2	DADO	NUT	ECROU	MUTTER
28	25290000/0	1	INDICATORE LIVELLO 18 - 20 HP B&S	FUEL LEVEL INDICATOR 18 - 20 HP B&S	INDICATEUR NIVEAU 18 - 20 HP B&S	KRAFTSTOFFMESSER 18 - 20 HP B&S
31	25961200/0	1	VOLANTE	STEERING WHEEL	VOLANT	LENKRAD
32	12620299/0	1	SPINA	PIN	GOUPILLE	STIFT
41	82000200/1	1	ACCELERATORE 12-12,5-13 -15,5 HP B&S 17 HP B&S 13 - 15 HP TECUMSEH 18 - 20 HP B&S	ACCELERATOR 12-12,5-13 -15,5 HP B&S 17 HP B&S 13 - 15 HP TECUMSEH 18 - 20 HP B&S	ACCELERATEUR 12-12,5-13 -15,5 HP B&S 17 HP B&S 13 - 15 HP TECUMSEH 18 - 20 HP B&S	GAS ZUG 12-12,5-13 -15,5 HP B&S 17 HP B&S 13 - 15 HP TECUMSEH 18 - 20 HP B&S
42	12788512/0	2	VITE	SCREW	VIS	SCHRAUBE
43	12581200/0	2	GROWER	GROWER	GROWER	GROWER
44	12521310/0	2	RONDELLA	WASHER	RONDELLE	SCHEIBE
45	25394501/0	1	MANOPOLINA	HANDLE	POIGNE	GRIFF
46	12726388/0	1	VITE	SCREW	VIS	SCHRAUBE
47	12290800/0	1	DADO	NUT	ECROU	MUTTER
48	25090000/0	1	COMANDO STARTER 18 - 20 HP B&S	STARTER DRIVE 18 - 20 HP B&S	COMMANDE STARTER 18 - 20 HP B&S	STARTER BETAETIGUNG 18 - 20 HP B&S
51	25722450/0	1	SEDILE	SEAT	SIEGE	SITZ
52	12793101/0	4	VITE	SCREW	VIS	SCHRAUBE
53	12583500/0	4	GROWER	GROWER	GROWER	GROWER
61	25110239/0	1	COPERTURA CENTRALE ROSSO	COVER RED	COUVRE ROUGE	KAPPE ROT
	25110240/0		VERDE	GREEN	VERT	GRÜN
	25110241/0		GIALLO	YELLOW	JAUNE	GELB
	25110242/0		BLU	BLUE	BLEU	BLAU
	25110219/0		ARANCIONE	ORANGE	ORANGE	DUNKELORANGE
62	25580020/0	1	VITE	SCREW	VIS	SCHRAUBE
63	25110270/0	1	COPRIPEDANA DESTRA	RIGHT FOOTBOARD COVER	COUVRE MARCHEPIED DRO.	RECHTE FUSSBRETTDECKEL
64	25110260/0	1	COPRIPEDANA SINISTRA	LEFT FOOTBOARD COVER	COUVRE MARCHEPIED GAU.	LINKE FUSSBRETTDECKEL
71	25110233/0	1	COPERTURA RUOTE ROSSO	WHEELS COVER RED	COUVRE-ROUES ROUGE	RADENKAPPE ROT
	25110234/0		VERDE	GREEN	VERT	GRÜN
	25110235/0		GIALLO	YELLOW	JAUNE	GELB
	25110236/0		BLU	BLUE	BLEU	BLAU
	25110249/0		ARANCIONE	ORANGE	ORANGE	DUNKELORANGE
72	12735402/0	4	VITE	SCREW	VIS	SCHRAUBE
81	82110191/0	1	COPERTURA SACCO ROSSO	GRASS-CATCHER COVER RED	COUVRE-BAC ROUGE	SACKKAPPE ROT
	82110192/0		VERDE	GREEN	VERT	GRÜN
	82110193/0		GIALLO	YELLOW	JAUNE	GELB
	82110194/0		BLU	BLUE	BLEU	BLAU
	82110196/0		ARANCIONE	ORANGE	ORANGE	DUNKELORANGE
82	25547016/1	1	PIASTRINA ROSSA	PLATE RED	PLAQUE ROUGE	PLATTE ROT
	25547015/0		VERDE	GREEN	VERT	GRÜN
	25547014/0		GIALLA	YELLOW	JAUNE	GELB
	25547024/0		BLU	BLUE	BLEU	BLAU
	25547093/0		ARANCIONE	ORANGE	ORANGE	DUNKELORANGE
83	12674701/0	2	VITE	SCREW	VIS	SCHRAUBE
84	12729601/0	4	VITE	SCREW	VIS	SCHRAUBE
85	12582101/0	2	GROWER	GROWER	GROWER	GROWER
86	12521331/0	6	RONDELLA	WASHER	RONDELLE	SCHEIBE

TC102 hy. TCP102 hy. TCR102 hy.

TC122 hy. TCP122 hy. TCR122 hy.

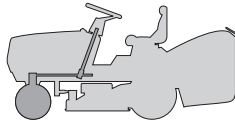

STERZO
STEERING
BARRE DE DIRECTION
LENKGETRIEBE

2000

003.0

1 / 2

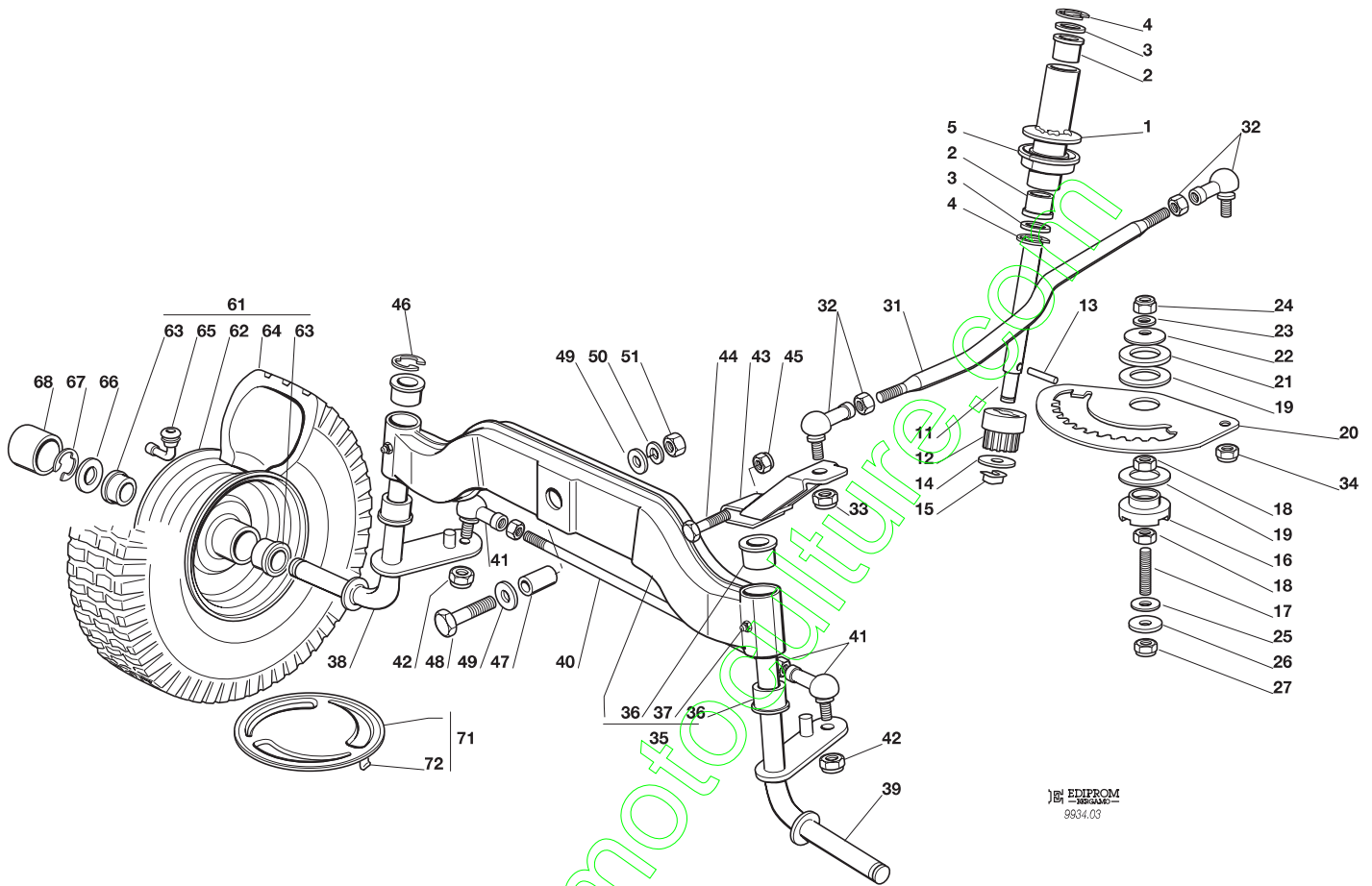

EDIPROM
9934.03

N.	CODE	Q.TY	DESCRIZIONE	DESCRIPTION	DESCRIPTION	BESCHREIBUNG
1	82869013/0	1	TUBO GUIDA PIANTONE	GUIDE TUBE	TUBE	ROHR
2	25040601/0	2	BUSSOLA	BUSH	DOUILLE	BÜCHSE
3	25670006/0	2	RONDELLA	WASHER	RONDELLE	SCHEIBE
4	12001000/0	2	SEEGER	SEEGER	SEEGER	SEEGER
5	25040602/0	2	BUSSOLA	BUSH	DOUILLE	BÜCHSE
11	25520002/1	1	PIANTONE	STEERING COLUMN	TUBE DE DIRECTION	LENKUNGSÆULE
12	25570000/0	1	PIGNONE	PINION	PIGNON	RITZEL
13	12622650/0	1	SPINA	PIN	GOUPILLE	STIFT
14	12521370/0	1	RONDELLA	WASHER	RONDELLE	SCHEIBE
15	12436030/0	1	PIASTRINA	PLATE	PLAQUETTE	PLATTECHEN
16	25040617/0	1	BUSSOLA	BUSH	DOUILLE	BÜCHSE
17	25510043/0	1	PRIGIONIERO	STUB SCREW	PRISSONIER	STIFTSCHIEBE
18	12295200/0	2	DADO	NUT	ECROU	MUTTER
19	25670012/0	2	RONDELLA	WASHER	RONDELLE	SCHEIBE
20	25735507/0	1	SETTORE	STEERING SHAFT	ARBRE DIRECTION	LENKUNGSWELLE
21	25670014/0	1	RONDELLA	WASHER	RONDELLE	SCHEIBE
22	22160400/0	1	DISCO ELASTICO	ELASTIC WASHER	DISQUE ELASTIQUE	FEDERSCHIEBE
23	12521360/0	1	ROSETTA	WASHER	RONDELLE	SCHEIBE
24	12156602/0	1	DADO	NUT	ECROU	MUTTER
25	22672150/0	1	RONDELLA	WASHER	RONDELLE	SCHEIBE
26	12523090/0	1	RONDELLA	WASHER	RONDELLE	SCHEIBE
27	12156602/0	1	DADO	NUT	ECROU	MUTTER
31	25033003/1	1	ASTA COMANDO STERZO	STEERING ROD	BARRE DE DIRECTION	LENKUNGSSTAB
32	22746600/0	2	SNODO	JOINT	JOINT	GELENK
33	12156602/0	1	DADO	NUT	ECROU	MUTTER
34	12295200/0	1	DADO	NUT	ECROU	MUTTER
35	82034001/2	1	BILANCIERE COMPLETO (CON 36 + 37)	EQUALIZER WITH BUSH (WITH 36 + 37)	BALANCIER AVEC (AVEC 36 + 37)	KIPPHEBEL (MIT 36 + 37)



N.	CODE	Q.TY	DESCRIZIONE	DESCRIPTION	DESCRIPTION	BESCHREIBUNG
36	25034002/1	4	BRONZINA	BRASS	COUSSINET	BÜCHSE
37	12379511/0	2	INGRASSATORE	GREASE DISPENSER	GRAISSEUR	FETTBÜCHSE
38	82230349/0	1	FUSELLO DESTRO	RIGHT STUB AXLE	FUSEAU DROITE	RECHTER ACHSSCHENKEL
39	82230348/0	1	FUSELLO SINISTRO	LEFT STUB AXLE	FUSEAU GAUCHE	LINKER ACHSSCHENKEL
40	25840001/0	1	TIRANTE	TIE ROD	TIRANT	KUPPLUNG
41	22746600/0	2	SNODO	JOINT	JOINT	GELENK
42	12156602/0	2	DADO	NUT	ECROU	MUTTER
43	82318101/0	1	LEVA COMANDO	LEVER	LEVIER	HEBEL
44	12691700/0	1	VITE	SCREW	VIS	SCHRAUBE
45	12155000/0	1	DADO	NUT	ECROU	MUTTER
46	12001000/0	1	ANELLO ELASTICO	SNAP RING	ANNEAU RESSORT	SPRENGRING
47	25160005/0	1	DISTANZIALE	SPACER	ENTRETOISE	ENTFERNUNGSSTUECK
48	12694100/0	1	VITE	SCREW	VIS	SCHRAUBE
49	12521390/0	2	RONDELLA	WASHER	RONDELLE	SCHEIBE
50	12587900/0	1	GROWER	GROWER	GROWER	GROWER
51	12295800/0	1	DADO	NUT	ECROU	MUTTER
61	☛	2	RUOTA ANTERIORE	FRONT WHEEL	ROUE AVANT	VORDERRAD
	82680002/1		TURF SAVER CARLISLE	TURF SAVER CARLISLE	TURF SAVER CARLISLE	TURF SAVER CARLISLE
	82680005/1		DELI TIRE	DELI TIRE	DELI TIRE	DELI TIRE
62	82000590/0	2	CERCHIO RUOTA	RIMM	BANDAGE ROUE	VORDERRAD FELGER
63	25122200/1	4	CUSCINETTO	BEARING	ROULEMENT	LAGER
64	☛	2	PNEUMATICO	TIRE	PNEU	REIFEN
	25590000/0		TURF SAVER CARLISLE	TURF SAVER CARLISLE	TURF SAVER CARLISLE	TURF SAVER CARLISLE
	25590002/0		DELI TIRE	DELI TIRE	DELI TIRE	DELI TIRE
65	25950002/0	2	VALVOLA	VALVE	SOUPAPE	VENTIL
66	25670005/1	2	RONDELLA	WASHER	RONDELLE	SCHEIBE
67	12001000/0	2	ANELLO ELASTICO	SNAP RING	ANNEAU RESSORT	SPRENGRING
68	22110230/0	2	COPRIMOZZO	HUB COVER	COUVRE MOYEU	RADNABE DECKEL
71	82110250/1	2	ASS. COPRIDISCO RUOTA ANTERIORE (TC - TCR)	FRONT WHEEL COVERENS. ASS.Y (TC - TCR)	COUVRE DISQUE ROUE ANTER. (TC - TCR)	VORRDERRAD DECKEL (TC - TCR)
	82110252/0	2	ASS. COPRIDISCO RUOTA ANTERIORE (TCP)	FRONT WHEEL COVERENS. ASS.Y (TCP)	COUVRE DISQUE ROUE ANTERIEURE (TCP)	VORRDERRAD DECKEL (TCP)
72	25430209/0	8	MOLLA AGGANCIAMENTO	SPRING	RESSORT	FEDER

www.emc-motoculture.com

TC102 hy. TCP102 hy. TCR102 hy.

TC122 hy. TCP122 hy. TCR122 hy.

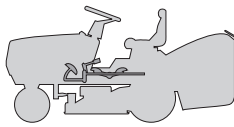

COMANDO TRASMISSIONE E FRENO
DRIVE AND BRAKE CONTROLS
COMMANDE TRANSMISSION ET FREIN
GETRIEBE UND BREMSE ANTRIEB

2000

004.0

1 / 2

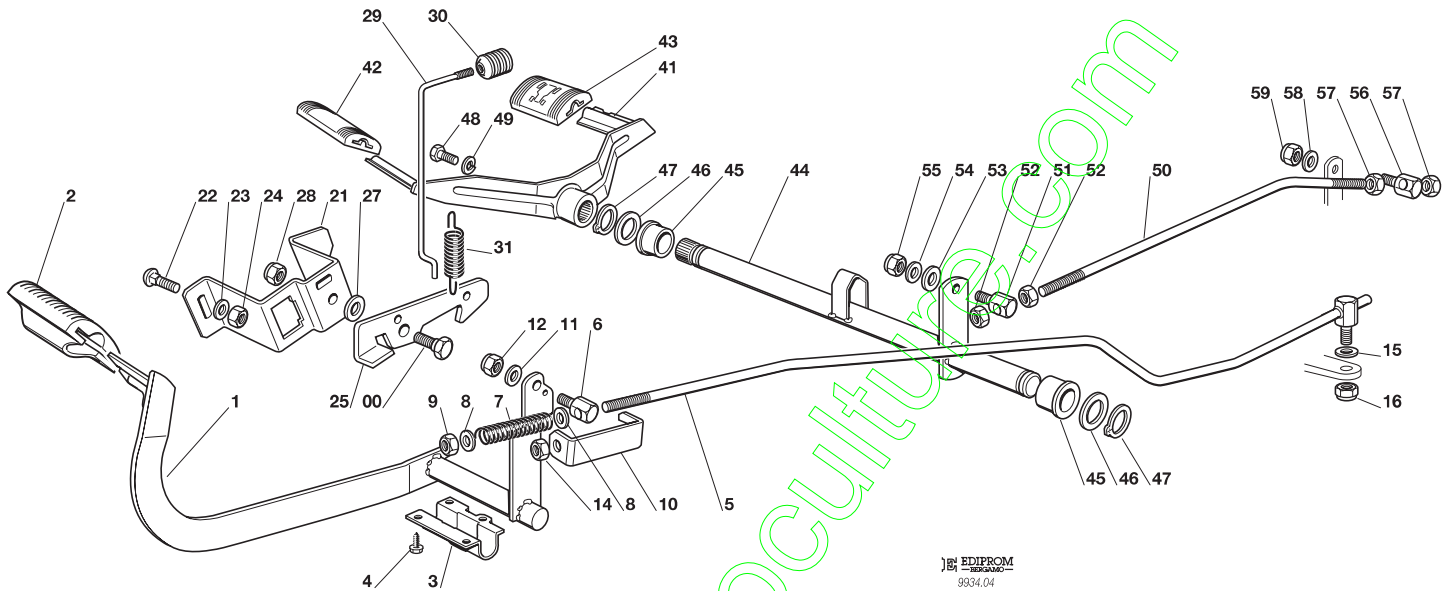

EDIPROM
9304.04

N.	CODE	Q.TY	DESCRIZIONE	DESCRIPTION	DESCRIPTION	BESCHREIBUNG
1	82500011/1	1	PEDALE	PEDAL	PEDAL	PEDAL
2	25110267/0	1	COPRISTAFFA	CLAMP COVER	COUVRE ETRIER	BRIDEDECKEL
3	25547081/0	1	PIASTRINA	PLATE	PLAQUE	PLATTE
4	12731601/0	4	VITE	SCREW	VIS	SCHRAUBE
5	82000487/0	1	ASTA	ROD	BARRE	STANGE
6	25510052/0	1	PERNO	PIN	PIVOT	BOLZEN
7	25430236/0	1	MOLLA	SPRING	RESSORT	FEDER
8	12521360/0	2	RONDELLA	WASHER	RONDELLE	SCHEIBE
9	12295200/0	1	DADO	NUT	ECROU	MUTTER
10	25774275/0	1	STAFFA	CLAMP	ETRIER	BRIDE
11	12521350/0	1	RONDELLA	WASHER	RONDELLE	SCHEIBE
12	12155000/0	1	DADO	NUT	ECROU	MUTTER
15	12521350/0	1	RONDELLA	WASHER	RONDELLE	SCHEIBE
16	12155000/0	1	DADO	NUT	ECROU	MUTTER
21	25785143/0	1	SUPPORTO	SUPPORT	SUPPORT	HALTER
22	12815210/0	4	VITE	SCREW	VIS	SCHRAUBE
23	12523040/0	1	RONDELLA	WASHER	RONDELLE	SCHEIBE
24	12154510/0	2	DADO	NUT	ECROU	MUTTER
25	25253001/0	1	GANCIO	HOOK	CROCHET	HAKEN
26	22524970/1	1	PERNO	PIN	PIVOT	BOLZEN
27	25670011/0	1	RONDELLA	WASHER	RONDELLE	SCHEIBE
28	12155000/0	1	DADO	NUT	ECROU	MUTTER
29	25033034/0	1	ASTA	ROD	BARRE	STANGE
30	25394509/0	1	MANOPOLA	KNOB	POIGNEE	KNOPF
31	25430213/0	1	MOLLA	SPRING	RESSORT	FEDER
41	82500013/0	1	PEDALE AVANZAMENTO	DRIVE PEDAL	PEDALE TRANSMISSION	GETRIEBEPEDAL
42	25110265/0	1	COPRISTAFFA ANTERIORE	CLAMP COVER FRONT	COUVRE ETRIER AVANT	BRIDEDECKEL VORDE
43	25110266/0	1	COPRISTAFFA POSTERIORE	CLAMP COVER REAR	COUVRE ETRIER ARRIERE	BRIDEDECKEL HINTER
44	82000481/0	1	ASSE AVANZAMENTO	AXLE	AXE	ACHSE



N.	CODE	Q.TY	DESCRIZIONE	DESCRIPTION	DESCRIPTION	BESCHREIBUNG
45	25034523/0	2	BRONZINA	BUSH	DOUILLE	BÜCHSE
46	22672153/0	2	RONDELLA	WASHER	RONDELLE	SCHEIBE
47	12609260/0	2	SEEGER	SEEGER	SEEGER	SEEGER
48	12760600/0	1	VITE	SCREW	VIS	SCHRAUBE
49	12583501/0	1	GROWER	GROWER	GROWER	GROWER
50	25033031/0	1	ASTA	ROD	BARRE	STANGE
51	25510054/0	1	PERNO	PIN	PIVOT	BOLZEN
52	12295200/0	2	DADO	NUT	ECROU	MUTTER
53	12521360/0	1	RONDELLA	WASHER	RONDELLE	SCHEIBE
54	12523040/0	1	RONDELLA	WASHER	RONDELLE	SCHEIBE
55	12154510/0	1	DADO	NUT	ECROU	MUTTER
56	25510054/0	1	PERNO	PIN	PIVOT	BOLZEN
57	12293200/0	2	DADO	NUT	ECROU	MUTTER
58	12523040/0	1	RONDELLA	WASHER	RONDELLE	SCHEIBE
59	12154510/0	1	DADO	NUT	ECROU	MUTTER

www.emc-motoculture.com

TC102 hy.

TCP102 hy.

TCR102 hy.

TC122 hy.

TCP122 hy.

TCR122 hy.

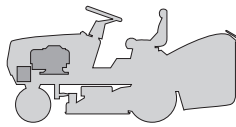
**MOTORE
ENGINE
MOTEUR
MOTOR**
12 - 12,5 - 13 HP B&S

2000

005.0

1 / 1

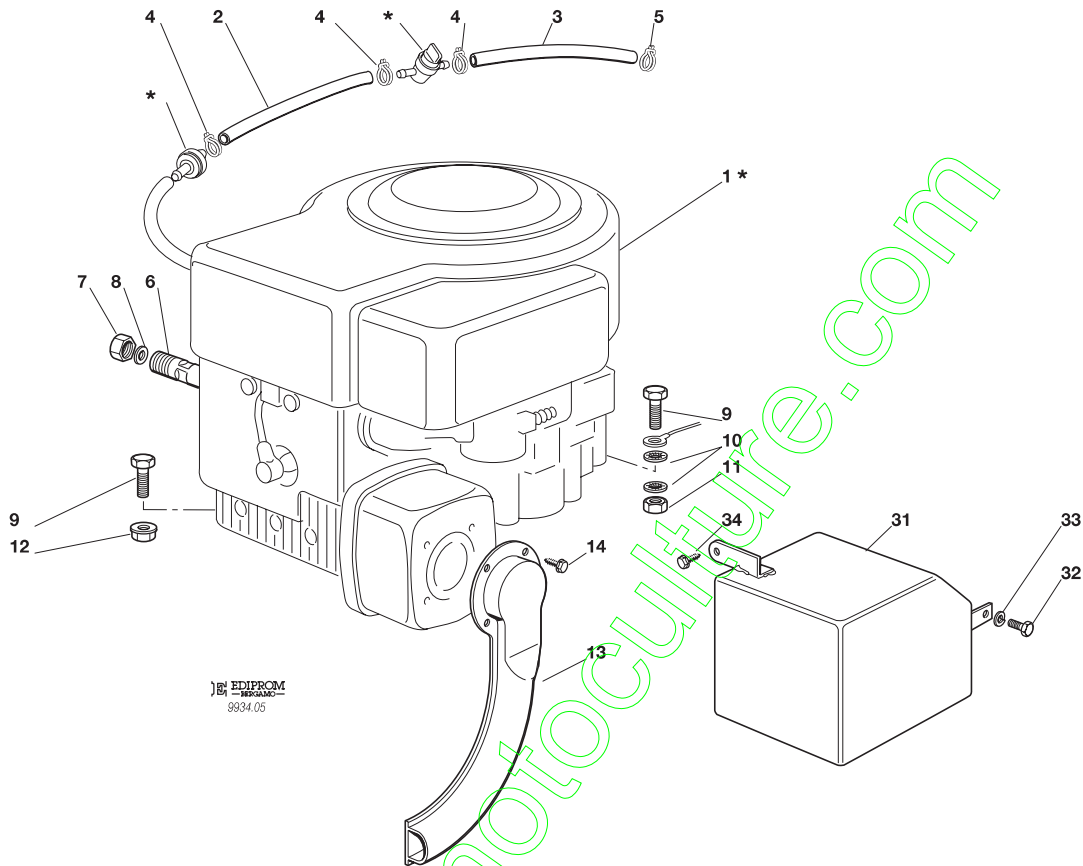

N.	CODE	Q.TY	DESCRIZIONE	DESCRIPTION	DESCRIPTION	BESCHREIBUNG
1*	—	1	MOTORE	ENGINE	MOTEUR	MOTOR
2	25869006/0	1	TUBO COLLEGAMENTO	CONNECTING TUBE	TUBE DE CONNEXION	VERBINDUNGSROHR
3	25869016/0	1	TUBO COLLEGAMENTO	CONNECTING TUBE	TUBE DE CONNEXION	VERBINDUNGSROHR
4	18375051/1	3	FASCETTA	FAIR LED	FIXATION DE CABLE	KABELBEFESTIGUNG
5	18375053/0	1	FASCETTA	FAIR LED	FIXATION DE CABLE	KABELBEFESTIGUNG
6	25598050/0	1	PROLUNGA SCARICO OLIO	OIL DISCHARGE EXTENSION	EXTENSION RALLONGE DE DECH. HUILE	ÖL ENTLEERUNGSVERLAEN- GERUNG
7	18737849/0	1	TAPPO PER PROLUNGA	OIL CAP	BOUCHON HUILE	OELVERSCHLUSS
8	18401001/0	1	GUARNIZIONE	OIL SEAL	GARNITURE	DICHTUNG
9	12691115/0	4	VITE	SCREW	VIS	SCHRAUBE
10	12540260/0	2	RONDELLA	WASHER	RONDELLE	SCHEIBE
11	12293200/0	1	DADO	NUT	ECROU	MUTTER
12	12293201/0	3	DADO	NUT	ECROU	MUTTER
13	82640001/1	1	RACCORDO SCARICO	EXHAUST CONNECTION	CONNEXION ECHAPPEMENT	AUSPUFFANSCHLUSS
14	12735106/0	4	VITE	SCREW	VIS	SCHRAUBE
31	82598001/0	1	PROTEZIONE SILENZIATORE	MUFFLER PROTECTION	PROTECTION SILENCIEUX	AUSPUFFSCHUTZ
32	12735510/0	1	VITE	SCREW	VIS	SCHRAUBE
33	12540260/0	1	RONDELLA	WASHER	RONDELLE	SCHEIBE
34	12735104/0	1	VITE	SCREW	VIS	SCHRAUBE

PER LA SOSTITUZIONE DELLE PARTI CONTRASSEGNAE CON «*» RIVOLGERSI AL SERVIZIO ASSISTENZA DEL COSTRUTTORE DEL MOTORE.
 TO REPLACE THE PARTS MARKED «*» SEEK ASSISTANCE FROM THE ENGINE MANUFACTURER'S AFTER SALES SERVICE.
 POUR LE REMPLACEMENT DES PIÈCES MARQUÉES AVEC «*» S'ADRESSER AU SERVICE APRÈS VENTES DU CONSTRUCTEUR DU MOTORE.
 ZUM AUSTAUSCH DER MIT «*» GEKENNZEICHNETEN TEILE, WENDEN SIE SICH AN DEN KUNDENDIENST DES HERSTELLERS DES MOTOR.

TC102 hy. TCP102 hy. TCR102 hy.

TC122 hy. TCP122 hy. TCR122 hy.

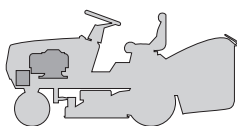

MOTORE
ENGINE
MOTEUR
MOTOR

15 - 15,5 - 17 HP B&S

2000

005a.0

1 / 2

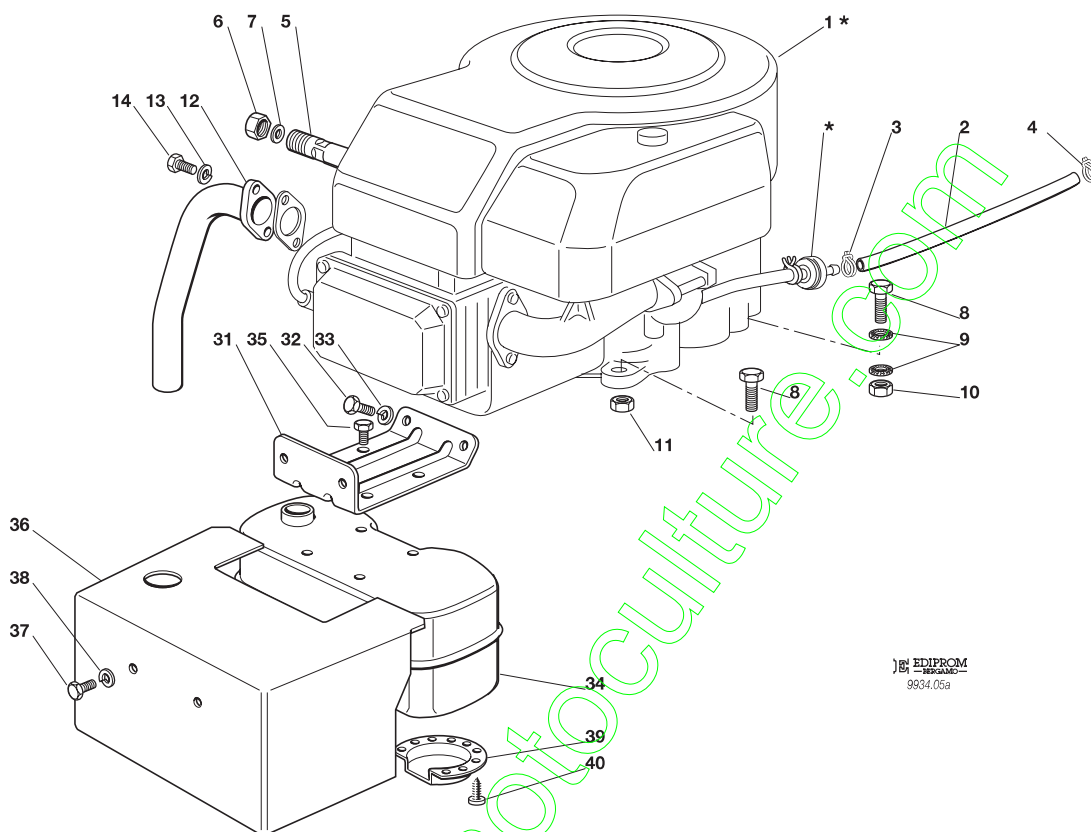

EDIPROM
9934.05a

N.	CODE	Q.TY	DESCRIZIONE	DESCRIPTION	DESCRIPTION	BESCHREIBUNG
1★	—	1	MOTORE	ENGINE	MOTEUR	MOTOR
2	25869016/0	1	TUBO COLLEGAMENTO	CONNECTING TUBE	TUBE DE CONNEXION	VERBINDUNGSROHR
3	18375051/1	1	FASCETTA	FAIR LED	FIXATION DE CABLE	KABELBEFESTIGUNG
4	18375053/0	1	FASCETTA	FAIR LED	FIXATION DE CABLE	KABELBEFESTIGUNG
5	25598050/0	1	PROLUNGA SCARICO OLIO	OIL DISCHARGE EXTENSION	EXTENSION RALLONGE DE DECH. HUILE	ÖL ENTLEERUNGSVERLAEN- GERUNG
6	18737849/0	1	TAPPO PROLUNGA	OIL CAP	BOUCHON HUILE	OELVERSCHLUSS
7	18401001/0	1	GUARNIZIONE	OIL SEAL	GARNITURE	DICHTUNG
8	12691100/0	4	VITE	SCREW	VIS	SCHRAUBE
9	12540260/0	2	RONDELLA	WASHER	RONDELLE	SCHEIBE
10	12293200/0	1	DADO	NUT	ECROU	MUTTER
11	12293201/0	3	DADO	NUT	ECROU	MUTTER
12	18738206/0	1	TUBO RACCORDO SCARICO	EXHAUST CONNECTING TUBE	TUBE DE CONNEXION POUR ECHAPPEMENT	VERBINDUNGSROHR FÜR ABGASUNG
13	12583500/0	2	GROWER	GROWER	GROWER	GROWER
14	12735530/0	2	VITE	SCREW	VIS	SCHRAUBE
31	82785093/0	1	SUPPORTO SILENZIATORE	MUFFLER SUPPORT	SUPPORT SILENCIEUX	AUSPUFFHALTERSATZ
32	12793102/0	1	VITE	SCREW	VIS	SCHRAUBE
33	12583500/0	2	GROWER	GROWER	GROWER	GROWER
34	18716132/0	1	SILENZIATORE COMPLETO DI DEFLETTORE	MUFFLER WITH DEFLECTOR	SILENCIEUX AVEC DEFLECTEUR	AUSPUFF MIT DEFLEKTOR
35	12735599/0	4	VITE	SCREW	VIS	SCHRAUBE
36	82598009/1	1	PROTEZIONE	GUARD	PROTECTION	SCHUTZE
37	12792611/0	2	VITE	SCREW	VIS	SCHRAUBE
38	12583500/0	2	GROWER	GROWER	GROWER	GROWER
39	18310005/0	1	DEFLETTORE	DEFLECTOR	DEFLECTEUR	DEFLEKTOR
40	12735106/0	4	VITE	SCREW	VIS	SCHRAUBE



N.	CODE	Q.TY	DESCRIZIONE	DESCRIPTION	DESCRIPTION	BESCHREIBUNG
----	------	------	-------------	-------------	-------------	--------------

PER LA SOSTITUZIONE DELLE PARTI CONTRASSEGNALE CON «*» RIVOLGERSI AL SERVIZIO ASSISTENZA DEL COSTRUTTORE DEL MOTORE.
 TO REPLACE THE PARTS MARKED «*» SEEK ASSISTANCE FROM THE ENGINE MANUFACTURER'S AFTER SALES SERVICE.
 POUR LE REMPLACEMENT DES PIÈCES MARQUÉES AVEC «*» S'ADRESSER AU SERVICE APRÈS VENTES DU CONSTRUCTEUR DU MOTEUR.
 ZUM AUSTAUSCH DER MIT «*» GEKENNZEICHNETEN TEILE, WENDEN SIE SICH AN DEN KUNDENDIENST DES HERSTELLERS DES MOTOR.

www.emc-motoculture.com

TC102 hy.	TCP102 hy.	TCR102 hy.
TC122 hy.	TCP122 hy.	TCR122 hy.

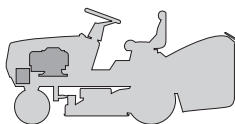

**MOTORE
ENGINE
MOTEUR
MOTOR**
18 - 20 HP B&S

2000
005b.0
1 / 2

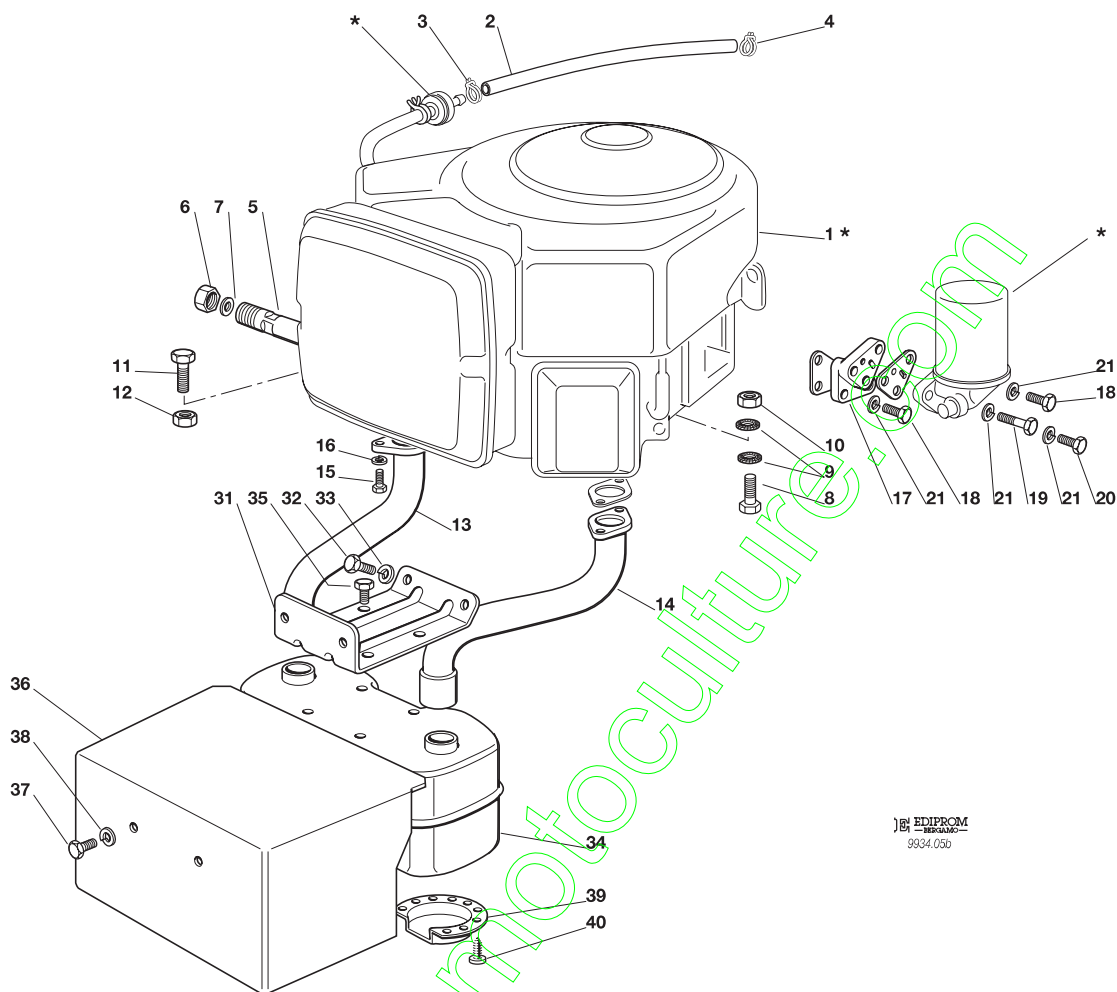

EDIPROM
9934.050

N.	CODE	Q.TY	DESCRIZIONE	DESCRIPTION	DESCRIPTION	BESCHREIBUNG
1*	—	1	MOTORE	ENGINE	MOTEUR	MOTOR
2	25869017/0	1	TUBO COLLEGAMENTO	CONNECTING TUBE	TUBE DE CONNEXION	VERBINDUNGSROHR
3	18375051/1	1	FASCETTA	FAIR LED	FIXATION DE CABLE	KABELBEFESTIGUNG
4	18375053/0	1	FASCETTA	FAIR LED	FIXATION DE CABLE	KABELBEFESTIGUNG
5	25598050/0	1	PROLUNGA SCARICO OLIO	OIL DISCHARGE EXTENSION	EXTENSION RALLONGE DE DECH. HUILE	ÖL ENTLEERUNGSVERLAEN- GERUNG
6	18737849/0	1	TAPPO PROLUNGA	OIL CAP	BOUCHON HUILE	OELVERSCHLUSS
7	18401001/0	1	GUARNIZIONE	OIL SEAL	GARNITURE	DICHTUNG
8	12691115/0	1	VITE	SCREW	VIS	SCHRAUBE
9	12540260/0	2	RONDELLA	WASHER	RONDELLE	SCHEIBE
10	12155010/0	1	DADO	NUT	ECROU	MUTTER
11	12691100/0	3	VITE	SCREW	VIS	SCHRAUBE
12	12293201/0	3	DADO	NUT	ECROU	MUTTER
13	18738202/0	1	TUBO RACCORDO SCARICO DX	EXHAUST RIGHT CONNECTING TUBE	TUBE DE CONNEXION DROIT POUR ECHAPP.	RECHTES VERBINDUNGS- ROHR FÜR ABGASUNG
14	18738203/0	1	TUBO RACCORDO SCARICO SX	EXHAUST LEFT CONNECTING TUBE	TUBE DE CONNEXION GAUCHE POUR ECHAPP.	LINKES VERBINDUNGS- ROHR FÜR ABGASUNG
15	12793101/0	4	VITE	SCREW	VIS	SCHRAUBE
16	12583500/0	4	GROWER	GROWER	GROWER	GROWER
17	25785095/0	1	SUPPORTO FILTRO	FILTER SUPPORT	SUPPORTE DU FILTRE	WECHSELFILTER HALTER
18	12791400/0	3	VITE	SCREW	VIS	SCHRAUBE
19	12689515/0	1	VITE	SCREW	VIS	SCHRAUBE
20	12791213/0	1	VITE	SCREW	VIS	SCHRAUBE
21	12582100/0	5	GROWER	GROWER	GROWER	GROWER
31	82785093/0	1	SUPPORTO SILENZIATORE	MUFFLER SUPPORT	SUPPORT SILENCIEUX	AUSPUFFHALTERSATZ
32	12793102/0	2	VITE	SCREW	VIS	SCHRAUBE
33	12583500/0	2	GROWER	GROWER	GROWER	GROWER
34	18716131/1	1	SILENZIATORE COMPLETO DI DEFLETTORE	MUFFLER WITH DEFLECTOR	SILENCEUX AVEC DEFLECTEUR	AUSPUFF MIT DEFLEKTOR
35	12735599/0	4	VITE	SCREW	VIS	SCHRAUBE



N.	CODE	Q.TY	DESCRIZIONE	DESCRIPTION	DESCRIPTION	BESCHREIBUNG
36	82598005/1	1	PROTEZIONE	GUARD	PROTECTION	SCHUTZE
37	12792610/0	2	VITE	SCREW	VIS	SCHRAUBE
38	12583500/0	2	GROWER	GROWER	GROWER	GROWER
39	18310005/0	1	DEFLETTORE	DEFLECTOR	DEFLECTEUR	DEFLEKTOR
40	12735106/0	4	VITE	SCREW	VIS	SCHRAUBE

PER LA SOSTITUZIONE DELLE PARTI CONTRASSEGNAE CON «*» RIVOLGERSI AL SERVIZIO ASSISTENZA DEL COSTRUTTORE DEL MOTORE.
 TO REPLACE THE PARTS MARKED «*» SEEK ASSISTANCE FROM THE ENGINE MANUFACTURER'S AFTER SALES SERVICE.
 POUR LE REMPLACEMENT DES PIÈCES MARQUÉES AVEC «*» S'ADRESSER AU SERVICE APRÈS VENTES DU CONSTRUCTEUR DU MOTEUR.
 ZUM AUSTAUSCH DER MIT «*» GEKENNZEICHNETEN TEILE, WENDEN SIE SICH AN DEN KUNDENDIENST DES HERSTELLERS DES MOTOR.

www.emc-motoculture.com

TC102 hy.

TCP102 hy.

TCR102 hy.

TC122 hy.

TCP122 hy.

TCR122 hy.

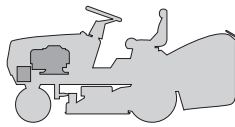

MOTORE
ENGINE
MOTEUR
MOTOR
13 HP TECUMSEH

2000

005c.0

1 / 2

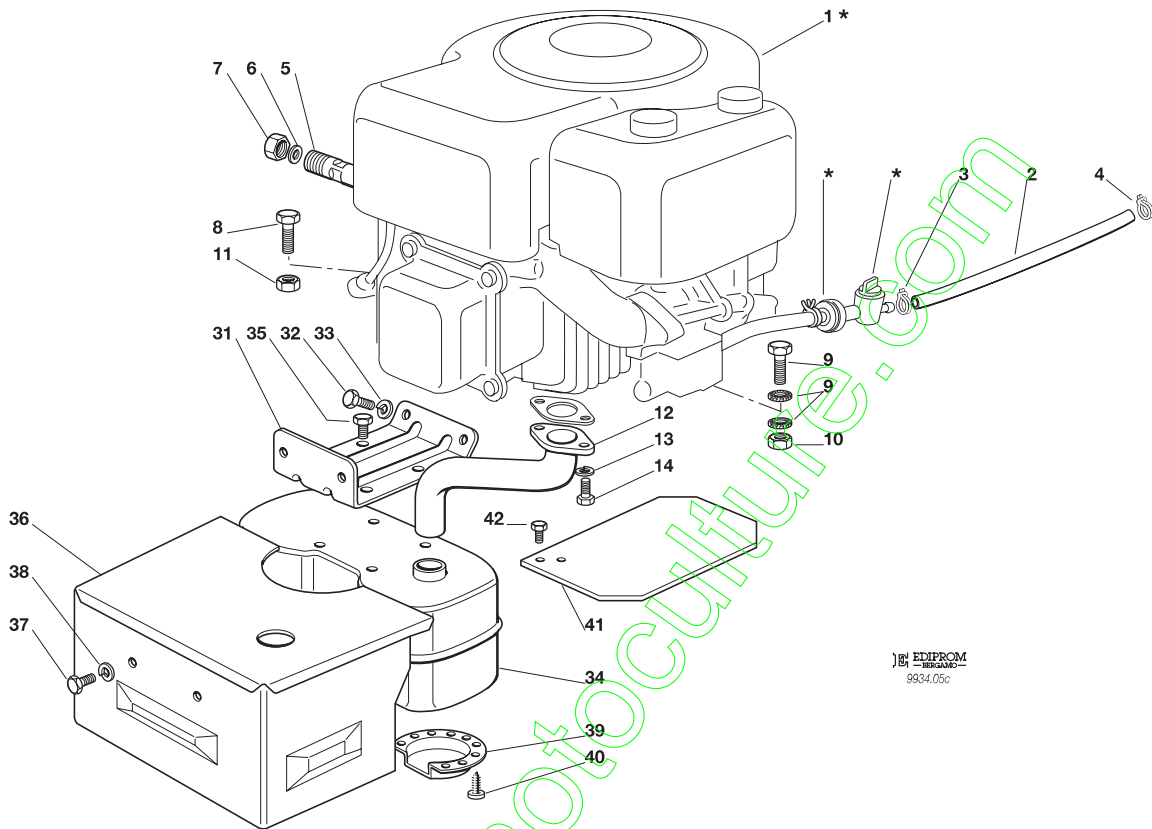

EDIPROM
9934.05c

N.	CODE	Q.TY	DESCRIZIONE	DESCRIPTION	DESCRIPTION	BESCHREIBUNG
1*	—	1	MOTORE	ENGINE	MOTEUR	MOTOR
2	25869027/0	1	TUBO COLLEGAMENTO	CONNECTING TUBE	TUBE DE CONNEXION	VERBINDUNGSROHR
3	18375051/1	1	FASCETTA	FAIR LED	FIXATION DE CABLE	KABELBEFESTIGUNG
4	18375053/0	1	FASCETTA	FAIR LED	FIXATION DE CABLE	KABELBEFESTIGUNG
5	25598050/0	1	PROLUNGA SCARICO OLIO	OIL DISCHARGE EXTENSION	EXTENSION RALLONGE DE DECH. HUILE	ÖL ENTLEERUNGSVERLAEN- GERUNG
6	18737849/0	1	TAPPO PROLUNGA	OIL CAP	BOUCHON HUILE	OELVERSCHLUSS
7	18401001/0	1	GUARNIZIONE	OIL SEAL	GARNITURE	DICHTUNG
8	12691100/0	4	VITE	SCREW	VIS	SCHRAUBE
9	12540260/0	2	RONDELLA	WASHER	RONDELLE	SCHEIBE
10	12293200/0	1	DADO	NUT	ECROU	MUTTER
11	12293201/0	3	DADO	NUT	ECROU	MUTTER
12	18738211/0	1	TUBO RACCORDO SCARICO	EXHAUST CONNECTING TUBE	TUBE DE CONNEXION POUR ECHAPPEMENT	VERBINDUNGSROHR FÜR ABGASUNG
13	12583500/0	2	GROWER	GROWER	GROWER	GROWER
14	12735530/0	2	VITE	SCREW	VIS	SCHRAUBE
31	82785093/0	1	SUPPORTO SILENZIATORE	MUFFLER SUPPORT	SUPPORT SILENCIEUX	AUSPUFFHALTERSATZ
32	12793102/0	2	VITE	SCREW	VIS	SCHRAUBE
33	12583500/0	2	GROWER	GROWER	GROWER	GROWER
34	18716132/0	1	SILENZIATORE COMPLETO DI DEFLETTORE	MUFFLER WITH DEFLECTOR	SILENCIEUX AVEC DEFLECTEUR	AUSPUFF MIT DEFLEKTOR
35	12735599/0	4	VITE	SCREW	VIS	SCHRAUBE
36	82598017/0	1	PROTEZIONE	GUARD	PROTECTION	SCHUTZE
37	12792611/0	2	VITE	SCREW	VIS	SCHRAUBE
38	12583500/0	2	GROWER	GROWER	GROWER	GROWER
39	18310005/0	1	DEFLETTORE	DEFLECTOR	DEFLECTEUR	DEFLEKTOR
40	12735106/0	4	VITE	SCREW	VIS	SCHRAUBE
41	25600031/0	1	PROTEZIONE SILENZIATORE	MUFFLER PROTECTION	PROTECTION SILENCIEUX	AUSPUFFSCHUTZ
42	12735106/0	2	VITE	SCREW	VIS	SCHRAUBE



N.	CODE	Q.TY	DESCRIZIONE	DESCRIPTION	DESCRIPTION	BESCHREIBUNG
----	------	------	-------------	-------------	-------------	--------------

PER LA SOSTITUZIONE DELLE PARTI CONTRASSEGNALE CON «*» RIVOLGERSI AL SERVIZIO ASSISTENZA DEL COSTRUTTORE DEL MOTORE.
 TO REPLACE THE PARTS MARKED «*» SEEK ASSISTANCE FROM THE ENGINE MANUFACTURER'S AFTER SALES SERVICE.
 POUR LE REMPLACEMENT DES PIÈCES MARQUÉES AVEC «*» S'ADRESSER AU SERVICE APRÈS VENTES DU CONSTRUCTEUR DU MOTEUR.
 ZUM AUSTAUSCH DER MIT «*» GEKENNZEICHNETEN TEILE, WENDEN SIE SICH AN DEN KUNDENDIENST DES HERSTELLERS DES MOTOR.

www.emc-motoculture.com

TC102 hy.

TCP102 hy.

TCR102 hy.

TC122 hy.

TCP122 hy.

TCR122 hy.

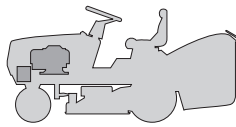

**MOTORE
ENGINE
MOTEUR
MOTOR**
15 HP TECUMSEH

2000

005d.0

1 / 2

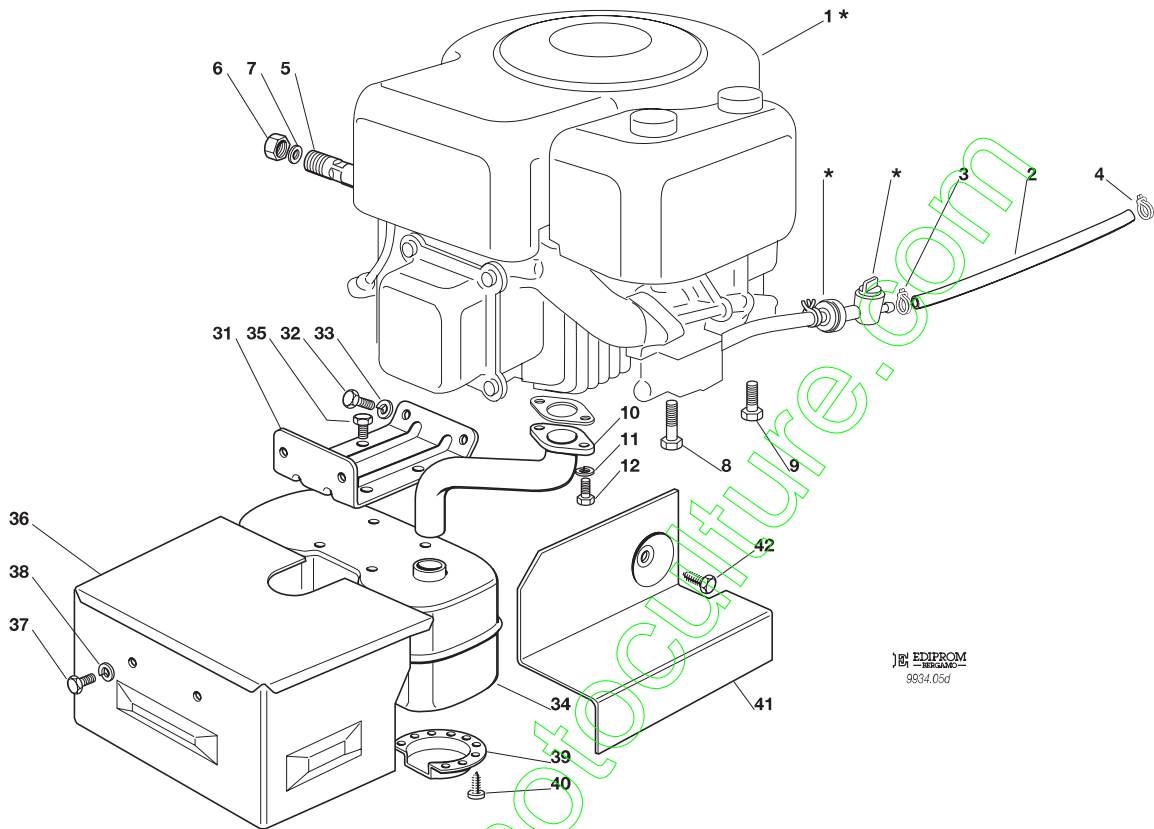

EDIPROM
9834.05d

N.	CODE	Q.TY	DESCRIZIONE	DESCRIPTION	DESCRIPTION	BESCHREIBUNG
1★	—	1	MOTORE	ENGINE	MOTEUR	MOTOR
2	25869027/0	1	TUBO COLLEGAMENTO	CONNECTING TUBE	TUBE DE CONNEXION	VERBINDUNGSROHR
3	18375051/1	1	FASCETTA	FAIR LED	FIXATION DE CABLE	KABELBEFESTIGUNG
4	18375053/0	1	FASCETTA	FAIR LED	FIXATION DE CABLE	KABELBEFESTIGUNG
5	25598050/0	1	PROLUNGA SCARICO OLIO	OIL DISCHARGE EXTENSION	EXTENSION RALLONGE DE DECH. HUILE	ÖL ENTLEERUNGSVERLAEN- GERUNG
6	18737849/0	1	TAPPO PROLUNGA	OIL CAP	BOUCHON HUILE	OELVERSCHLUSS
7	18401001/0	1	GUARNIZIONE	OIL SEAL	GARNITURE	DICHTUNG
8	12735108/0	1	VITE	SCREW	VIS	SCHRAUBE
9	12735109/0	3	VITE	SCREW	VIS	SCHRAUBE
10	18738212/0	1	TUBO RACCORDO SCARICO	EXHAUST CONNECTING TUBE	TUBE DE CONNEXION POUR ECHAPPEMENT	VERBINDUNGSROHR FÜR ABGASUNG
11	12583500/0	2	GROWER	GROWER	GROWER	GROWER
12	12735530/0	2	VITE	SCREW	VIS	SCHRAUBE
31	82785093/0	1	SUPPORTO SILENZIATORE	MUFFLER SUPPORT	SUPPORT SILENCIEUX	AUSPUFFHALTERSATZ
32	12793102/0	2	VITE	SCREW	VIS	SCHRAUBE
33	12583500/0	2	GROWER	GROWER	GROWER	GROWER
34	18716132/0	1	SILENZIATORE COMPLETO DI DEFLETTORE	MUFFLER WITH DEFLECTOR	SILENCEUX AVEC DEFLECTEUR	AUSPUFF MIT DEFLEKTOR
35	12735599/0	4	VITE	SCREW	VIS	SCHRAUBE
36	82598019/0	1	PROTEZIONE	GUARD	PROTECTION	SCHUTZE
37	12792611/0	2	VITE	SCREW	VIS	SCHRAUBE
38	12583500/0	2	GROWER	GROWER	GROWER	GROWER
39	18310005/0	1	DEFLETTORE	DEFLECTOR	DEFLECTEUR	DEFLEKTOR
40	12735106/0	4	VITE	SCREW	VIS	SCHRAUBE
41	25600038/0	1	PROTEZIONE SILENZIATORE	MUFFLER PROTECTION	PROTECTION SILENCIEUX	AUSPUFFSCHUTZ
42	12734995/0	1	VITE	SCREW	VIS	SCHRAUBE



N.	CODE	Q.TY	DESCRIZIONE	DESCRIPTION	DESCRIPTION	BESCHREIBUNG
----	------	------	-------------	-------------	-------------	--------------

PER LA SOSTITUZIONE DELLE PARTI CONTRASSEGNALE CON «*» RIVOLGERSI AL SERVIZIO ASSISTENZA DEL COSTRUTTORE DEL MOTORE.
 TO REPLACE THE PARTS MARKED «*» SEEK ASSISTANCE FROM THE ENGINE MANUFACTURER'S AFTER SALES SERVICE.
 POUR LE REMPLACEMENT DES PIÈCES MARQUÉES AVEC «*» S'ADRESSER AU SERVICE APRÈS VENTES DU CONSTRUCTEUR DU MOTEUR.
 ZUM AUSTAUSCH DER MIT «*» GEKENNZEICHNETEN TEILE, WENDEN SIE SICH AN DEN KUNDENDIENST DES HERSTELLERS DES MOTOR.

www.emc-motoculture.com

TC102 hy. TCP102 hy. TCR102 hy.

TC122 hy. TCP122 hy. TCR122 hy.

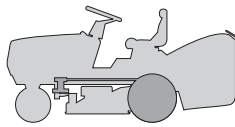

TRASMISSIONE
TRANSMISSION
TRANSMISSION
GETRIEBE

2000

006.0

1 / 2

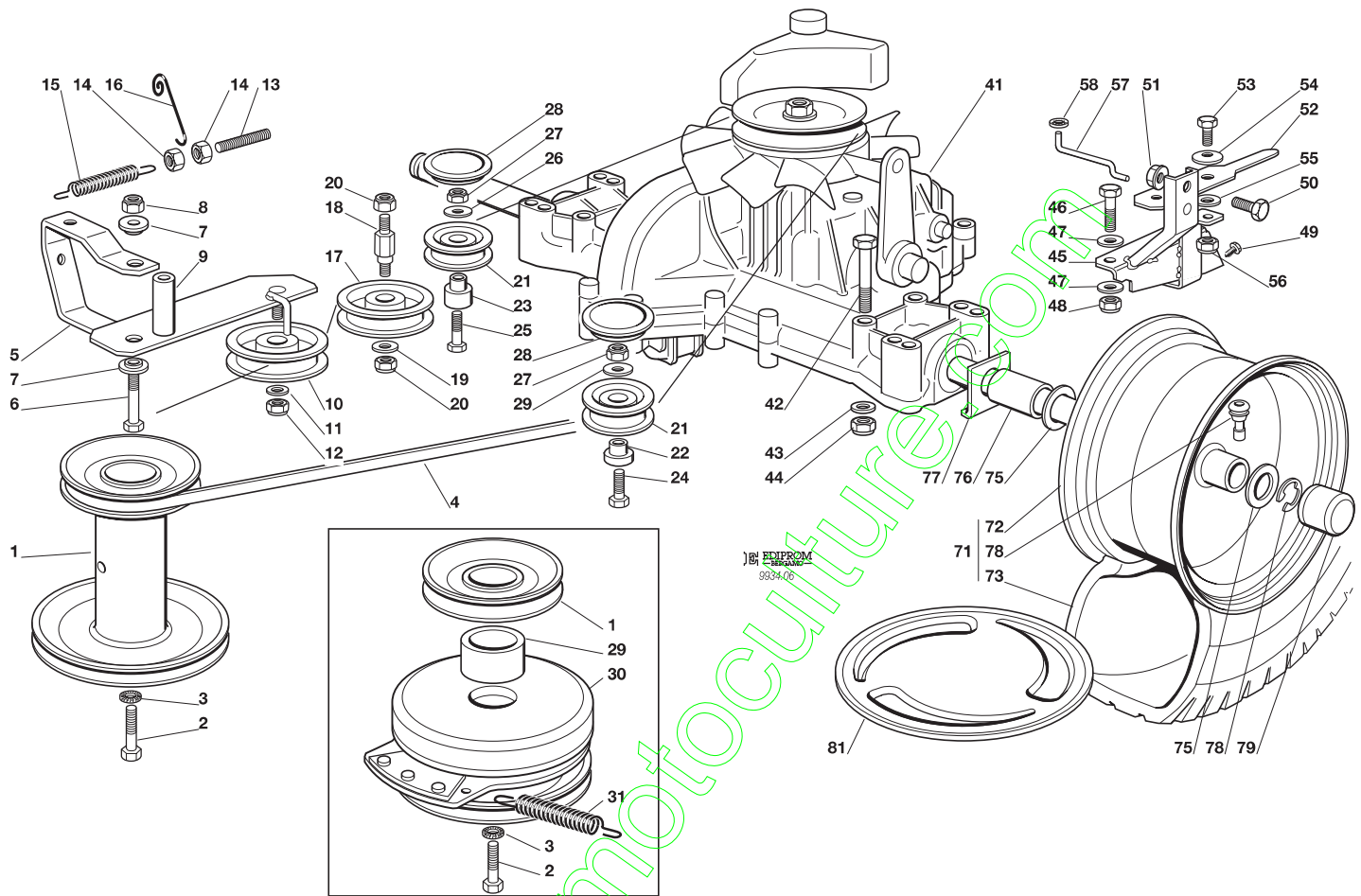

N.	CODE	Q.TY	DESCRIZIONE	DESCRIPTION	DESCRIPTION	BESCHREIBUNG
3	12543000/0	1	ROSETTA	WASHER	RONDELLE	SCHEIBE
4	35062001/0	1	CINGHIA	BELT	COURROIE	RIEMEN
5	82318165/0	1	LEVA	LEVER	LEVIER	HEBEL
6	12692000/0	1	VITE	SCREW	VIS	SCHRAUBE
7	25038002/1	2	BOCCOLA	BUSH	DOUILLE	BÜCHSE
8	12155000/0	1	DADO	NUT	ECROU	MUTTER
9	25160027/0	1	DISTANZIALE	SPACER	ENTRETOISE	ENTFERNUNGSSTÜCK
10	25601554/0	1	PULEGGIA	PULLEY	POULIE	RIEMENSCHLEIBE
11	12523060/0	1	RONDELLA	WASHER	RONDELLE	SCHEIBE
12	12155000/0	1	DADO	NUT	ECROU	MUTTER
13	25840010/0	1	TIRANTE	TIE ROD	TIRANT	SPANNSTANGE
14	12293200/0	2	DADO	NUT	ECROU	MUTTER
15	25430219/0	1	MOLLA	SPRING	RESSORT	FEDER
16	27430557/0	1	MOLLA	SPRING	RESSORT	FEDER
17	25601555/0	1	PULEGGIA	PULLEY	POULIE	RIEMENSCHLEIBE
18	25510036/0	1	PERNO	PIN	PIVOT	BOLZEN
19	12523060/0	1	RONDELLA	WASHER	RONDELLE	SCHEIBE
20	12155000/0	2	DADO	NUT	ECROU	MUTTER
21	25601558/1	2	PULEGGIA	PULLEY	POULIE	RIEMENSCHLEIBE
22	25160018/0	1	DISTANZIALE SINISTRO	LEFT SPACER	ENTRETOISE GAUCHE	LINKER ABSTANDSSTÜCK
23	25160024/0	1	DISTANZIALE DESTRO	RIGHT SPACER	ENTRETOISE DROITE	RECHTER ABSTANDSSTÜCK
24	12691100/0	1	VITE	SCREW	VIS	SCHRAUBE
25	12691400/0	1	VITE	RIGHT SCREW	VIS	SCHRAUBE
26	12523060/0	2	RONDELLA	WASHER	RONDELLE	SCHEIBE
27	12155000/0	2	DADO	NUT	ECROU	MUTTER
28	25109521/0	2	COPERCHIO	COVER	COUVERCLE	DECKEL
41★	18400950/0	1	ASSE POSTERIORE	REAR AXLE	AXE ARRIERE	HINTERACHSE
42	12691800/0	4	VITE	SCREW	VIS	SCHRAUBE
43	12521350/0	4	RONDELLA	WASHER	RONDELLE	SCHEIBE
44	12155000/0	4	DADO	NUT	ECROU	MUTTER



N.	CODE	Q.TY	DESCRIZIONE	DESCRIPTION	DESCRIPTION	BESCHREIBUNG
45	82785109/0	1	SUPPORTO	SUPPORT	SUPPORT	HALTER
46	12691200/0	1	VITE	SCREW	VIS	SCHRAUBE
47	12521350/0	2	RONDELLA	WASHER	RONDELLE	SCHEIBE
48	12155000/0	1	DADO	NUT	ECROU	MUTTER
49	12735120/0	1	VITE	SCREW	VIS	SCHRAUBE
50	12792611/0	1	VITE	SCREW	VIS	SCHRAUBE
51	12293201/0	1	DADO	NUT	ECROU	MUTTER
52	25318157/0	1	LEVA	LEVER	LEVIER	HEBEL
53	12793102/0	1	VITE	SCREW	VIS	SCHRAUBE
54	12369500/0	1	DISCO ELASTICO	ELASTIC WASHER	DISQUE ELASTIQUE	FEDERSCHEIBE
55	25670011/0	1	RONDELLA	WASHER	RONDELLE	SCHEIBE
56	12155000/0	1	DADO	NUT	ECROU	MUTTER
57	25033033/0	1	ASTA	ROD	BARRE	STANGE
58	12604896/0	1	FISSATORE A CORONA	CROWN FASTENER	FIXATEUR A COURONNE	KRONESCHEIBE
71	82680003/0	2	RUOTA POSTERIORE TURF SAVER CARLISLE	REAR WHEEL TURF SAVER CARLISLE	ROUE ARRIERE TURF SAVER CARLISLE	HINTERRAD TURF SAVER CARLISLE
	82680006/0		DELI TIRE	DELI TIRE	DELI TIRE	DELI TIRE
72	82000592/0	2	CERCHIO RUOTA	RIMM	BANDAGE ROUE	HINTRERRAD FELGER
73	25590001/0	2	PNEUMATICO TURF SAVER CARLISLE	SHOE TURF SAVER CARLISLE	PNEU TURF SAVER CARLISLE	REIFEN TURF SAVER CARLISLE
	25590003/0		DELI TIRE	DELI TIRE	DELI TIRE	DELI TIRE
74	25950000/0	2	VALVOLA	VALVE	SOUPAPE	VENTIL
75	25670005/1	2	RONDELLA	WASHER	RONDELLE	SCHEIBE
76	25160023/0	2	DISTANZIALE	SPACER	ENTRETOISE	ENTFERNUNGSSTÜCK
77	25670017/0	2	RONDELLA	WASHER	RONDELLE	SCHEIBE
78	12001010/0	2	ANELLO ELASTICO	SNAP RING	ANNEAU RESSORT	SPRENGRING
79	22110230/0	2	COPRIMOZZO	HUB COVER	COUVRE MOYEU	NABEDECKEL
81	82110251/1	2	COPRIRUOTA POST. (TC - TCR)	REAR WHEEL DECK (TC - TCR)	COUVRE ROUE POST. (TC - TCR)	HINTERRADDECKEL (TC - TCR)
	82110253/0	2	COPRIRUOTA POST. (TCP)	REAR WHEEL DECK (TCP)	COUVRE ROUE POST. (TCP)	HINTERRADDECKEL (TCP)
			Nei modelli con innesto delle lame a leva:	For models with engagement of the blades by lever:	Dans les modèles avec embrayage des lames à levier:	Bei Modellen mit Hebelschaltung der Messer:
1	25601568/0	1	PULEGGIA	PULLEY	POULIE	RIEMENSCHLEIBE
2	12737310/0	1	VITE	SCREW	VIS	SCHRAUBE
			Nei modelli con innesto delle lame elettromagnetico:	For models with engagement of the blades by electromagnetic clutch:	Dans les modèles avec embrayage des lames électromagnétique:	Bei Modellen mit elektromagnetischer Schaltung der Messer:
1	25601566/0	1	PULEGGIA	PULLEY	POULIE	RIEMENSCHLEIBE
2	12737320/0	1	VITE	SCREW	VIS	SCHRAUBE
29	25160021/0	1	DISTANZIALE	SPACER	ENTRETOISE	ENTFERNUNGSSTÜCK
30	18399060/0	1	FRIZIONE	CLUTC	EMBRAJAGE	KUPPLUNG
31	25430210/0	1	MOLLA	SPRING	RESSORT	FEDER

PER LA SOSTITUZIONE IN GARANZIA DELLE PARTI CONTRASSEGNAE CON «*» RIVOLGERSI AL SERVIZIO ASSISTENZA DEL COSTRUTTORE (TUFF TORQ).

TO REPLACE UNDER GUARANTEE THE PARTS MARKED «*» SEEK ASSISTANCE FROM MANUFACTURER'S AFTER SALES SERVICE (TUFF TORQ).
POUR LE REMPLACEMENT, SOUS GARANTIE DES PIÈCES MARQUÉES AVEC «*» S'ADRESSER AU SERVICE APRÈS VENTES DU CONSTRUCTEUR (TUFF TORQ).

ZUM AUSTAUSCH DER MIT «*» GEKENNZEICHNETEN TEILE IM RAHMEN DER GARANTIE, WENDEN SIE SICH AN DEN KUNDENDIENST DES HERSTELLERS (TUFF TORQ).

TC102 hy. TCP102 hy. TCR102 hy.

TC122 hy. TCP122 hy. TCR122 hy.

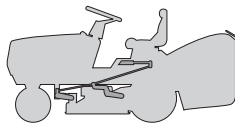

SOLLEVAMENTO PIATTO DI TAGLIO
CUTTING PLATE LIFTING
SOULEVEMENT PLATEAU DE COUPE
SCHNEIDWERKZEUG AUFHEBESATZ

2000

007.0

1 / 2

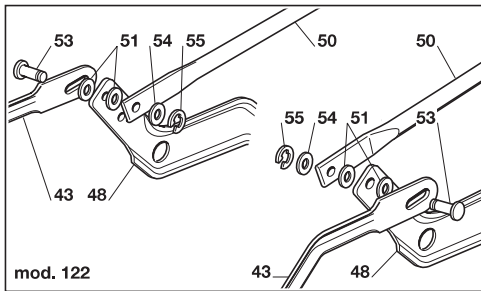

mod. 122

43

48

50

51

53

54

55

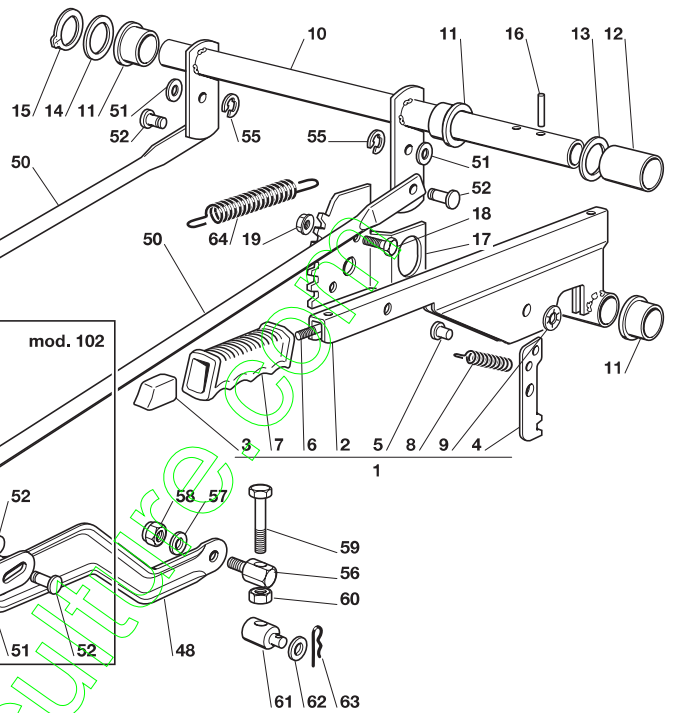

mod. 102

EDIPROM
9934.07

N.	CODE	Q.TY	DESCRIZIONE	DESCRIPTION	DESCRIPTION	BESCHREIBUNG
1	82300002/0	1	ASSIEME LEVA (2 ÷ 9)	LEVER ASS.Y (2 ÷ 9)	ENS. LEVIER (2 ÷ 9)	AUFHEBENHEBEL (2 ÷ 9)
2	82318139/0	1	LEVA	LEVER	LEVIER	HEBEL
3	25605000/1	1	PULSANTE	BUTTON	POUSSOIR	DRUCKKNOPF
4	25470901/0	1	NASELLO	DOG	DECLIC	NASE
5	25510011/0	1	PERNO	PIN	PIVOT	BOLZEN
6	25033002/0	1	ASTA	ROD	TIGE	STAB
7	25394504/0	1	MANOPOLA	KNOB	POIGNEE	GRIFF
8	25430208/0	1	MOLLA	SPRING	RESSORT	FEDER
9	12604899/0	1	FISSATORE A CORONA	CROWN FASTENER	FIXATEUR A COURONNE	KRONESCHEIBE
10	82000479/0	1	ASSE	AXLE	AXE	ACHSE
11	22034523/0	3	BOCCOLA	BUSH	DOUILLE	BÜCHSE
12	25160025/0	1	DISTANZIALE	SPACER	ENTRETOISE	ENTFERNUNGSSTÜCK
13	22672153/0	1	RONDELLA	WASHER	RONDELLE	SCHEIBE
14	12521410/0	1	RONDELLA	WASHER	RONDELLE	SCHEIBE
15	12609260/0	1	SEEGER	SEEGER	SEEGER	SEEGER
16	12620206/0	2	SPINA	PIN	GOUPILLE	STIFT
17	25735506/1	1	SETTORE	SECTOR	SECTEUR	SEKTOR
18	12792611/0	2	VITE	SCREW	VIS	SCHRAUBE
19	12293201/0	2	DADO	NUT	ECROU	MUTTER
31	82318155/0	1	LEVA ANTERIORE DESTRA (mod. 102)	FRONT RIGHT LEVER (mod. 102)	LEVIER ANT. DROITE (mod. 102)	RECHTER VORDERHEBEL (mod. 102)
	82318159/0	1	LEVA ANTERIORE DESTRA (mod. 122)	FRONT RIGHT LEVER (mod. 122)	LEVIER ANT. DROITE (mod. 122)	RECHTER VORDERHEBEL (mod. 122)
32	82318157/0	1	LEVA ANTERIORE SINISTRA (mod. 102)	FRONT LEFT LEVER (mod. 102)	LEVIER ANT. GAUCHE (mod. 102)	LINKER VORDERHEBEL (mod. 102)
	82318161/0	1	LEVA ANTERIORE SINISTRA (mod. 122)	FRONT LEFT LEVER (mod. 122)	LEVIER ANT. GAUCHE (mod. 122)	LINKER VORDERHEBEL (mod. 122)
33	25040605/0	4	BUSSOLA	BUSH	DOUILLE	BÜCHSE
34	25318161/0	2	LEVA	LEVER	LEVIER	HEBEL
35	12691700/0	2	VITE	SCREW	VIS	SCHRAUBE



N.	CODE	Q.TY	DESCRIZIONE	DESCRIPTION	DESCRIPTION	BESCHREIBUNG
36	12521350/0	2	RONDELLA	WASHER	RONDELLE	SCHEIBE
37	12155000/0	2	DADO	NUT	ECROU	MUTTER
38	25510076/0	2	PERNO	PIN	PIVOT	BOLZEN
39	12295200/0	2	DADO	NUT	ECROU	MUTTER
40	12156602/0	2	DADO	NUT	ECROU	MUTTER
41	25670008/0	4	RONDELLA	WASHER	RONDELLE	SCHEIBE
42	12156602/0	2	DADO	NUT	ECROU	MUTTER
43	82000477/0	2	ASTA COLLEGAMENTO	CONNECTING ROD	TIGE DE CONNEXION	VERBINDUNGSSTAB
44	12155000/0	4	DADO	NUT	ECROU	MUTTER
45	25510055/0	2	PERNO	PIN	PIVOT	BOLZEN
46	12521350/0	2	RONDELLA	WASHER	RONDELLE	SCHEIBE
47	12155000/0	2	DADO	NUT	ECROU	MUTTER
48	25318153/0	2	LEVA POSTERIORE	REAR LEVER	LEVIER ARRIERE	HINTERHEBEL
49	12609255/0	2	SEEGER	SEEGER	SEEGER	SEEGER
50	25033029/0	2	ASTA COLLEGAMENTO	CONNECTING ROD	TIGE DE CONNEXION	VERBINDUNGSSTAB
51	25670011/0	6	RONDELLA	WASHER	RONDELLE	SCHEIBE
52	25510053/0	6	PERNO (mod. 102)	PIN (mod. 102)	PIVOT (mod. 102)	BOLZEN (mod. 102)
		2	PERNO (mod. 122)	PIN (mod. 122)	PIVOT (mod. 122)	BOLZEN (mod. 122)
53	25510048/0	2	PERNO (mod. 122)	PIN (mod. 122)	PIVOT (mod. 122)	BOLZEN (mod. 122)
54	12521350/0	2	RONDELLA	WASHER	RONDELLE	SCHEIBE
55	12436050/0	6	PIASTRINA (mod. 102)	PLATE (mod. 102)	PLAQUETTE (mod. 102)	PLATTE (mod. 102)
		4	PIASTRINA (mod. 122)	PLATE (mod. 122)	PLAQUETTE (mod. 122)	PLATTE (mod. 122)
56	25510056/0	2	PERNO	PIN	PIVOT	BOLZEN
57	25670008/0	4	RONDELLA	WASHER	RONDELLE	SCHEIBE
58	12156602/0	2	DADO	NUT	ECROU	MUTTER
59	12794980/0	2	VITE	SCREW	VIS	SCHRAUBE
60	12295200/0	4	DADO	NUT	ECROU	MUTTER
61	25510051/0	2	PERNO	PIN	PIVOT	BOLZEN
62	12523100/0	2	RONDELLA	WASHER	RONDELLE	SCHEIBE
63	24487998/0	2	COPPIGLIA	COTTER PIN	GOUILLE	SPLIT
64	25430218/0	1	MOLLA	SPRING	RESSORT	FEDER
65	12543000/0	2	RONDELLA	WASHER	RONDELLE	SCHEIBE

www.emc-motostructure.com

TC102 hy. TCP102 hy. TCR102 hy.

TC122 hy. TCP122 hy. TCR122 hy.

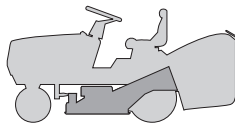

PIATTO DI TAGLIO (1)
CUTTING PLATE (1)
PLATEAU DE COUPE (1)
SCHNEIDWERKZEUG (1)

2000

008.0

1 / 2

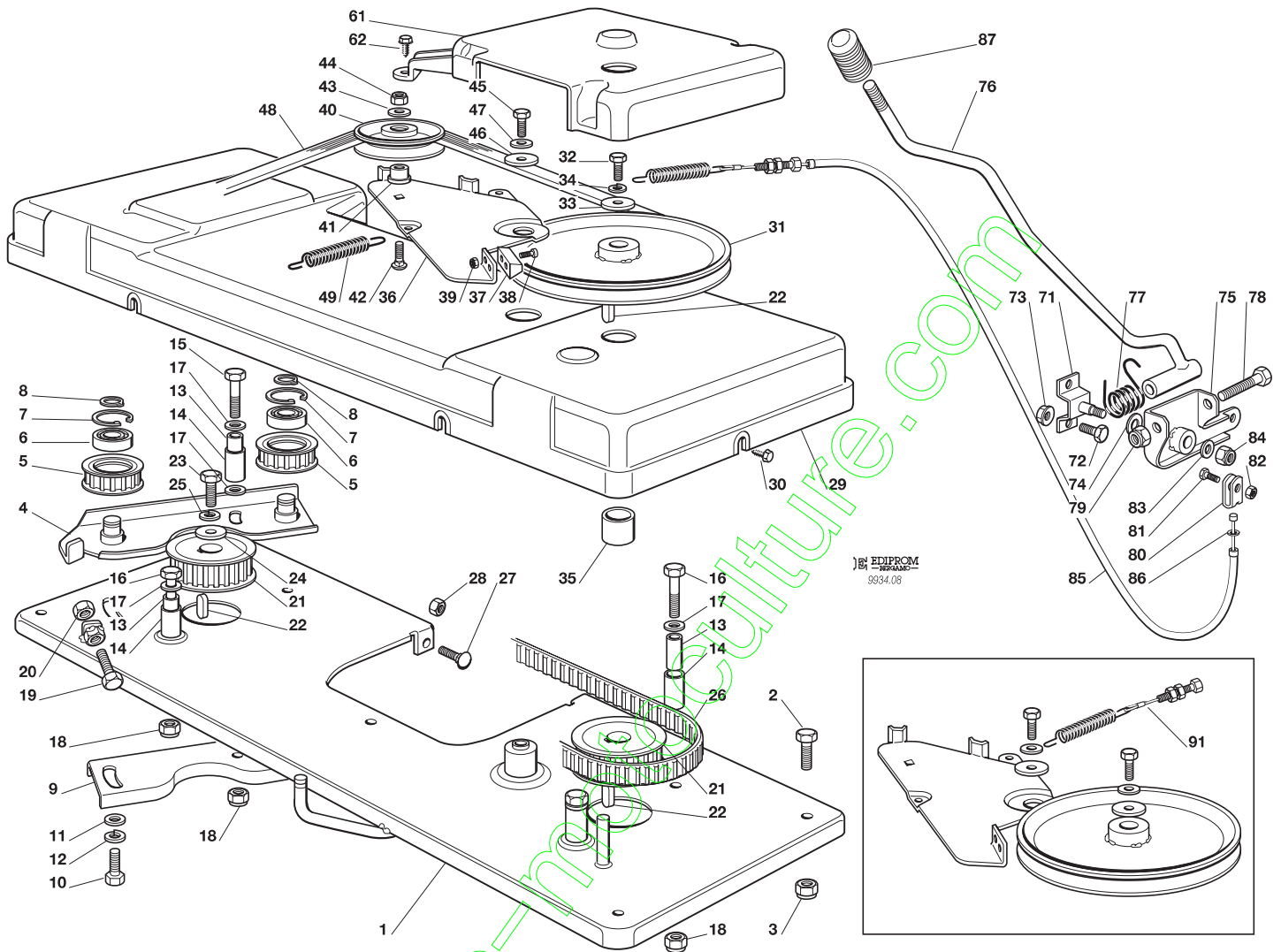

N.	CODE	Q.TY	DESCRIZIONE	DESCRIPTION	DESCRIPTION	BESCHREIBUNG
----	------	------	-------------	-------------	-------------	--------------

1	82547003/2	1	PIASTRA (mod. 102)	PLATE (mod. 102)	PLATE (mod. 102)	PLATTE (mod. 102)
	82547005/1	1	PIASTRA (mod. 122)	PLATE (mod. 122)	PLATE (mod. 122)	PLATTE (mod. 122)
2	12792611/0	4	VITE	SCREW	VIS	SCHRAUBE
3	12293201/0	4	DADO	NUT	ECROU	MUTTER
4	82785084/1	1	SUPPORTO	SUPPORT	SUPPORT	HALTERSATZ
5	25601559/1	2	PULEGGIA (mod. 102)	PULLEY (mod. 102)	POULIE (mod. 102)	RIEMENSCHLEIBE (mod. 102)
	25601561/0	2	PULEGGIA (mod. 122)	PULLEY (mod. 122)	POULIE (mod. 122)	RIEMENSCHLEIBE (mod. 122)
6	19216033/1	2	CUSCINETTO	BEARING	ROULEMENT	KUEGELLAGER
7	12610800/0	2	SEEGER	SEEGER	SEEGER	SEEGER
8	12609200/0	2	SEEGER	SEEGER	SEEGER	SEEGER
9	25650037/0	1	RINFORZO	STIFFENING	REINFORCEMENT	VERSTAERKUNG
10	12793102/0	2	VITE	SCREW	VIS	SCHRAUBE
11	12521350/0	2	RONDELLA	WASHER	RONDELLE	SCHEIBE
12	12583500/0	2	GROWER	GROWER	GROWER	GROWER
13	25160003/0	4	DISTANZIALE	SPACER	ENTRETOISE	DISTANZRING
14	25038000/0	4	BOCCOLA	BUSHING	DOUILLE	BUCHSE
15	12691700/0	1	VITE	SCREW	VIS	SCHRAUBE
16	12691200/0	3	VITE	SCREW	VIS	SCHRAUBE
17	12521350/0	5	RONDELLA	WASHER	RONDELLE	SCHEIBE
18	12155000/0	4	DADO	NUT	ECROU	MUTTER
19	12793900/0	1	VITE	SCREW	VIS	SCHRAUBE
20	12293200/0	1	DADO	NUT	ECROU	MUTTER
21	25601560/0	2	PULEGGIA (mod. 102)	PULLEY (mod. 102)	POULIE (mod. 102)	RIEMENSCHLEIBE (mod. 102)
	25601562/0	2	PULEGGIA (mod. 122)	PULLEY (mod. 122)	POULIE (mod. 122)	RIEMENSCHLEIBE (mod. 122)
22	12139480/0	3	CHIAVETTA	KEY	CLAVETTE	KEIL
23	12793102/0	1	VITE	SCREW	VIS	SCHRAUBE
24	25670007/0	1	RONDELLA	WASHER	RONDELLE	SCHEIBE
25	12583500/0	1	GROWER	GROWER	GROWER	GROWER



N.	CODE	Q.TY	DESCRIZIONE	DESCRIPTION	DESCRIPTION	BESCHREIBUNG
26	35065600/0	1	CINGHIA (mod. 102)	BELT (mod. 102)	COURROIRE (mod. 102)	KEILRIEMEN (mod. 102)
	35065601/0	1	CINGHIA (mod. 122)	BELT (mod. 122)	COURROIRE (mod. 122)	KEILRIEMEN (mod. 122)
27	12815200/0	3	VITE	SCREW	VIS	SCHRAUBE
28	12292102/0	3	DADO	NUT	ECROU	MUTTER
29	25060100/2	1	CARTER (mod. 102)	CASE (mod. 102)	CARTER (mod. 102)	BLECH (mod. 102)
	25060101/1	1	CARTER (mod. 122)	CASE (mod. 122)	CARTER (mod. 122)	BLECH (mod. 122)
30	12735110/0	6	VITE	SCREW	VIS	SCHRAUBE
31	25601550/0	1	PULEGGIA (mod. 102)	PULLEY (mod. 102)	POULIE (mod. 102)	RIEMENSCHIEBE (mod. 102)
	25601549/0	1	PULEGGIA (mod. 122)	PULLEY (mod. 122)	POULIE (mod. 122)	RIEMENSCHIEBE (mod. 122)
32	12793102/0	1	VITE	SCREW	VIS	SCHRAUBE
33	25670007/0	1	RONDELLA	WASHER	RONDELLE	SCHIEBE
34	12583500/0	1	GROWER	GROWER	GROWER	GROWER
35	25160002/0	1	DISTANZIALE	SPACER	ENTRETOISE	DISTANZRING
36	25318115/1	1	LEVA FRENO (mod. 102)	BRAKE LEVER (mod. 102)	LEVIER FREIN (mod. 102)	BREMSHEBEL (mod. 102)
	25318119/0	1	LEVA FRENO (mod. 102)	BRAKE LEVER (mod. 102)	LEVIER FREIN (mod. 102)	BREMSHEBEL (mod. 102)
40	25601555/0	1	PULEGGIA	PULLY	POULIE	RIEMENSCHIEBE
41	25160007/0	1	DISTANZIALE	SPACER	ENTRETOISE	DISTANZRING
42	12818900/0	1	VITE	SCREW	VIS	SCHRAUBE
43	12523060/0	1	RONDELLA	WASHER	RONDELLE	SCHIEBE
44	12155000/0	1	DADO	NUT	ECROU	MUTTER
45	12793102/0	1	VITE	SCREW	VIS	SCHRAUBE
46	12523070/0	1	RONDELLA	WASHER	RONDELLE	SCHIEBE
47	12583500/0	1	GROWER	GROWER	GROWER	GROWER
61	25600049/0	1	PROTEZIONE (mod. 102)	GUARD (mod. 102)	PROTECTION (mod. 102)	SCHUTZ (mod. 102)
	25600050/0	1	PROTEZIONE (mod. 122)	GUARD (mod. 122)	PROTECTION (mod. 122)	SCHUTZ (mod. 122)
62	12735402/0	3	VITE	SCREW	VIS	SCHRAUBE
			Nei modelli con innesto delle lame a leva:	For models with engagement of the blades by lever:	Dans les modèles avec embrayage des lames à levier:	Bei Modellen mit Hebelschaltung der Messer:
37	25207000/1	1	FERODO	LINING	PASTILLE FREIN	BREMSBELAG
38	12771400/0	2	VITE	SCREW	VIS	SCHRAUBE
39	12154330/0	2	DADO	NUT	ECROU	MUTTER
48	35062813/0	1	CINGHIA (mod. 102)	BELT (mod. 102)	COURROIE (mod. 102)	KEIL RIEMEN (mod. 102)
	35062814/0	1	CINGHIA (mod. 122)	BELT (mod. 122)	COURROIE (mod. 122)	KEIL RIEMEN (mod. 122)
49	25430210/0	1	MOLLA (mod. 102)	SPRING (mod. 102)	RESSORT (mod. 102)	FEDER (mod. 102)
	25430220/0	1	MOLLA (mod. 122)	SPRING (mod. 122)	RESSORT (mod. 122)	FEDER (mod. 122)
71	82774227/0	1	SUPPORTO	SUPPORT	SUPPORT	HALTER
72	12792611/0	2	VITE	SCREW	VIS	SCHRAUBE
73	12293201/0	2	DADO	NUT	ECROU	MUTTER
74	22672151/0	1	RONDELLA	WASHER	RONDELLE	SCHIEBE
75	82774204/1	1	STAFFA	CLAMP	BRIDE	BRIDE
76	82318162/0	1	LEVA	LEVER	LEVIER	HEBEL
77	25430227/0	1	MOLLA	SPRING	RESSORT	FEDER
78	12692050/0	1	VITE	SCREW	VIS	SCHRAUBE
79	12155000/0	1	DADO	NUT	ECROU	MUTTER
80	22061337/0	1	CAVALLOTTO	CONNECTING PLATE	PAQUE DE CONNEXION	BUGEL BOLZEN
81	12791213/0	1	VITE	SCREW	VIS	SCHRAUBE
82	12154510/0	1	DADO	NUT	ECROU	MUTTER
83	12523060/0	1	RONDELLA	WASHER	RONDELLE	SCHIEBE
84	12155010/0	1	DADO	NUT	ECROU	MUTTER
85	82004606/0	1	FILO (mod. 102)	WIRE (mod. 102)	FIL (mod. 102)	KABEL (mod. 102)
	82004607/0	1	FILO (mod. 122)	WIRE (mod. 122)	FIL (mod. 122)	KABEL (mod. 122)
86	12521350/0	1	RONDELLA	WASHER	RONDELLE	SCHIEBE
87	25394503/1	1	MANOPOLA	KNOB	POIGNEE	GRIFF
			Nei modelli con innesto delle lame elettromagnetico:	For models with engagement of the blades by electromagnetic clutch:	Dans les modèles avec embrayage des lames électromagnétique:	Bei Modellen mit elektromagnetischer Schaltung der Messer:
48	35062811/0	1	CINGHIA (mod. 102)	BELT (mod. 102)	COURROIE (mod. 102)	KEIL RIEMEN (mod. 102)
	35062812/0	1	CINGHIA (mod. 122)	BELT (mod. 122)	COURROIE (mod. 122)	KEIL RIEMEN (mod. 122)
91	82004608/0	1	FILO (mod. 102)	WIRE (mod. 102)	FIL (mod. 102)	KABEL (mod. 102)
	82004609/0	1	FILO (mod. 122)	WIRE (mod. 122)	FIL (mod. 122)	KABEL (mod. 122)

TC102 hy. TCP102 hy. TCR102 hy.

TC122 hy. TCP122 hy. TCR122 hy.

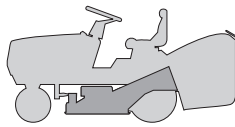

PIATTO DI TAGLIO (2)
CUTTING PLATE (2)
PLATEAU DE COUPE (2)
SCHNEIDWERKZEUG (2)

2000

009.0

1 / 2

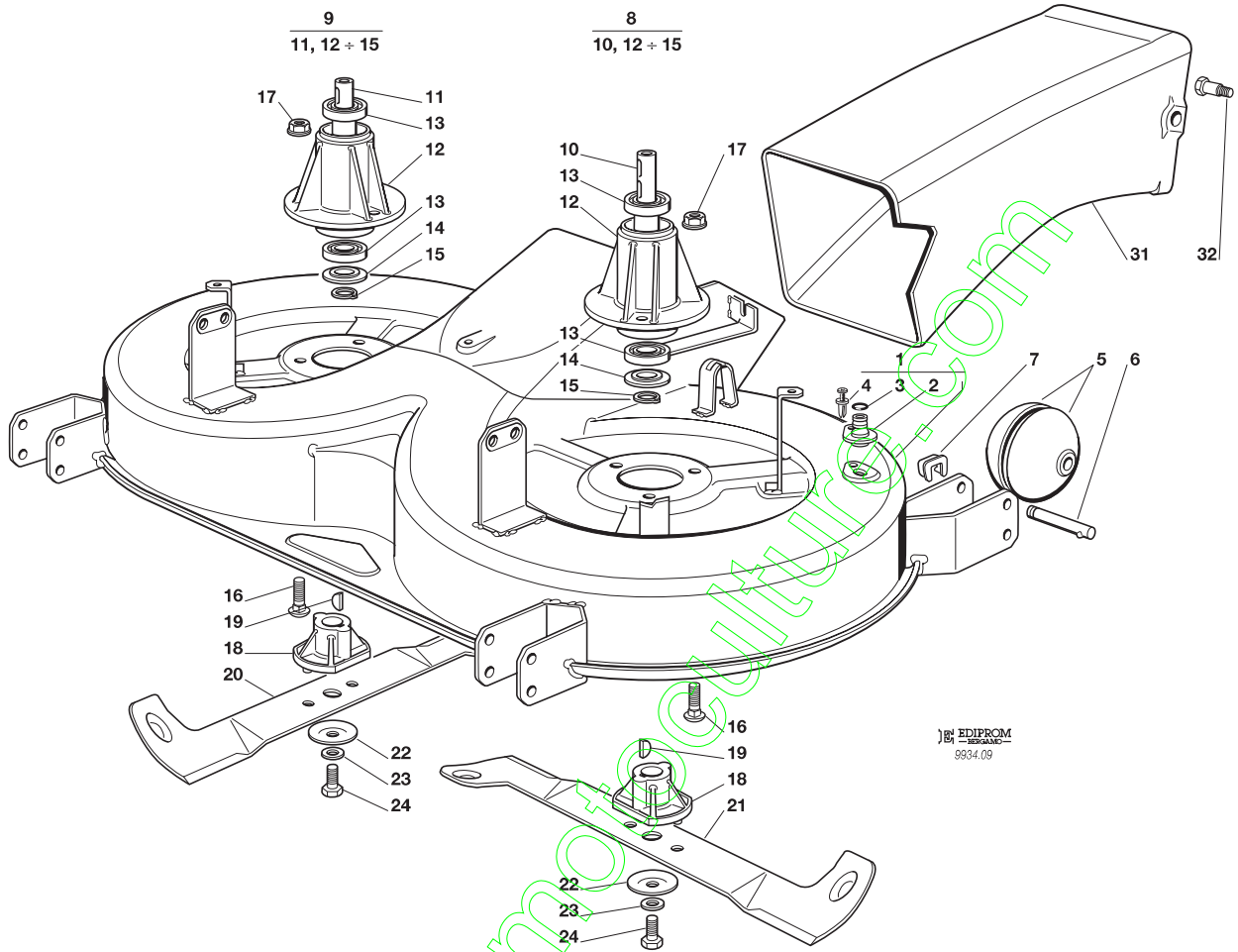

EDIPROM
9834.09

N.	CODE	Q.TY	DESCRIZIONE	DESCRIPTION	DESCRIPTION	BESCHREIBUNG
1	82565010/0	1	ASSIEME PIATTO DI TAGLIO (CON 2 - 3 - 4) (mod. 102)	CUTTING PLATE ASS.Y (WITH 2 - 3 - 4) (mod. 102)	ENS. PATEAU DE COUPE (AVEC 2 - 3 - 4) (mod. 102)	SCHNEIDWERKZEUG (MIT 2 - 3 - 4) (mod. 102)
	82565011/0	1	ASSIEME PIATTO DI TAGLIO (CON 2 - 3 - 4) (mod. 122)	CUTTING PLATE ASS.Y (WITH 2 - 3 - 4) (mod. 122)	ENS. PATEAU DE COUPE (AVEC 2 - 3 - 4) (mod. 122)	SCHNEIDWERKZEUG (MIT 2 - 3 - 4) (mod. 122)
2	25033060/0	2	ATTACCO TUBO ACQUA	WATER HOSE CONNECTION	RACCORD TUYAU D'EAU	WASSERANSCHLUSS
3	19035000/0	2	ANELLO OR	O RING	O RING	O RING
4	12500030/0	2	RIVETTO	RIVET	RIVET	NIET
5	82700000/0	4	RUOTINO ANTISCALPO	LEVELLING SMALL WHEEL	ROULETTES ANTISCALP	EBENUNGRAEDCHEN
6	25510006/0	4	PERNO	PIN	PIVOT	BOLZEN
7	12436030/0	4	PIASTRINA	PLATE	PLAQUE	PLATTE
8	82207200/1	1	ASS. FLANGIA ALBERO PRINCIPALE (10, 12÷15)	BLADE MAIN SHAFT SUPPORT (10, 12÷15)	SUPPORT ARBRE LAME PRINCIPAL (10, 12÷15)	MASSERWELLEHAPT- SATZ (10, 12÷15)
9	82207201/2	1	ASS. FLANGIA ALBERO SECONDARIO (11, 12÷15)	BLADE SECONDARY SHAFT SUPPORT (11, 12÷15)	SUPPORT ARBRE LAME SECONDAIRE (11, 12÷15)	MASSERWELLE ZWEITER- SATZ (11, 12÷15)
10	25020800/1	1	ALBERO LAMA PRINCIPALE	MAIN BLADE SHAFT	ARBRE LAME PRINCIPAL	HAUP MESSERWELLE
11	25020801/2	1	ALBERO LAMA SECONDARIO	SECONDARY BLADE SHAFT	ARBRE LAME SECONDAIRE	ZWEITE MESSERWELLE
12	25207200/0	2	FLANGIA ALBERO LAMA	BLADE SHAFT SUPPORT	SUPPORT ARBRE LAME	MESSERWELLE
13	19216032/0	4	CUSCINETTO	BEARING	ROULEMENT	KUEGELLAGER
14	25160501/0	2	DISCO PARAPOLVERE	DUST COVER	PROTEGE-POUSSIERE	STAUBSCHUTTSCHIEBE
15	12609260/0	2	SEEGER	SEEGER	SEEGER	SEEGER
16	12818700/0	6	VITE	SCREW	VIS	SCHRAUBE
17	12154210/0	6	DADO	NUT	ECROU	MUTTER
18	25463200/0	2	MOZZO COLTELLO	BLADE HUB	MOYEU LAME	MESSERHALTER
19	12139100/0	2	LINGUETTA	KEY	CLAVETTE	KEIL
20	82004341/0	1	COLTELLO DX (mod. 102)	RIGHT BLADE (mod. 102)	LAME DROITE (mod. 102)	RECHTER MESSER (mod. 102)
	82004343/0	1	COLTELLO DX (mod. 122)	RIGHT BLADE (mod. 122)	LAME DROITE (mod. 122)	RECHTER MESSER (mod. 122)
21	82004340/0	1	COLTELLO SX (mod. 102)	LEFT BLADE (mod. 102)	LAME GAUCHE (mod. 102)	LINKER MESSER (mod. 102)
	82004342/0	1	COLTELLO SX (mod. 122)	LEFT BLADE (mod. 122)	LAME GAUCHE (mod. 122)	LINKER MESSER (mod. 122)
22	22160400/0	2	DISCO ELASTICO	ELASTIC WASHER	RONDELLE ELASTIQUE	FEDERSCHIEBE
23	12523080/0	2	RONDELLA	WASHER	RONDELLE	SCHEIBE
24	12735694/0	1	VITE	SCREW	VIS	SCHRAUBE



N.	CODE	Q.TY	DESCRIZIONE	DESCRIPTION	DESCRIPTION	BESCHREIBUNG
25	12735695/1	1	VITE	SCREW	VIS	SCHRAUBE
31	25108009/0	1	CONVOGLIATORE POSTER.	REAR CONVEYOR ASS.Y	ENS. CONVOYEUR POST.	HINTERLEITBLECHSATZ
32	25510051/0	2	VITE	SCREW	VIS	SCHRAUBE
			Nei modelli con innesto delle lame a leva:	For models with engagement of the blades by lever:	Dans les modèles avec embrayage des lames à levier:	Bei Modellen mit Hebelschaltung der Messer:
—	82565015/0	1	PIATTO DI TAGLIO ASSEMBLATO (mod. 102) (008, 1÷62 + 009, 1÷25)	CUTTING PLATE, ASSEMBLED (mod. 102) (008, 1÷62 + 009, 1÷25)	PLATEAU DE COUPE, COMPLETE (mod. 102) (008, 1÷62 + 009, 1÷25)	CHNEIDWERKZEUG, KOMPLETT (mod. 102) (008, 1÷62 + 009, 1÷25)
—	82565016/0	1	PIATTO DI TAGLIO ASSEMBLATO (mod. 122) (008, 1÷62 + 009, 1÷25)	CUTTING PLATE, ASSEMBLED (mod. 122) (008, 1÷62 + 009, 1÷25)	PLATEAU DE COUPE, COMPLETE (mod. 122) (008, 1÷62 + 009, 1÷25)	CHNEIDWERKZEUG, KOMPLETT (mod. 122) (008, 1÷62 + 009, 1÷25)
			Nei modelli con innesto delle lame elettromagnetico:	For models with engagement of the blades by electromagnetic clutch:	Dans les modèles avec embrayage des lames électromagnétique:	Bei Modellen mit elektromagnetischer Schaltung der Messer:
—	82565020/0	1	PIATTO DI TAGLIO ASSEMBLATO (mod. 102) (008, 1÷62 + 009, 1÷25)	CUTTING PLATE, ASSEMBLED (mod. 102) (008, 1÷62 + 009, 1÷25)	PLATEAU DE COUPE, COMPLETE (mod. 102) (008, 1÷62 + 009, 1÷25)	CHNEIDWERKZEUG, KOMPLETT (mod. 102) (008, 1÷62 + 009, 1÷25)
—	82565021/0	1	PIATTO DI TAGLIO ASSEMBLATO (mod. 122) (008, 1÷62 + 009, 1÷25)	CUTTING PLATE, ASSEMBLED (mod. 122) (008, 1÷62 + 009, 1÷25)	PLATEAU DE COUPE, COMPLETE (mod. 122) (008, 1÷62 + 009, 1÷25)	CHNEIDWERKZEUG, KOMPLETT (mod. 122) (008, 1÷62 + 009, 1÷25)

www.emc-motoculture.com

TC102 hy. TCP102 hy. TCR102 hy.

TC122 hy. TCP122 hy. TCR122 hy.

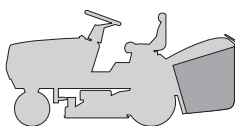

SACCO
GRASSCATCHER
BAC
AUFFANGSACK

2000

010.0

1 / 1

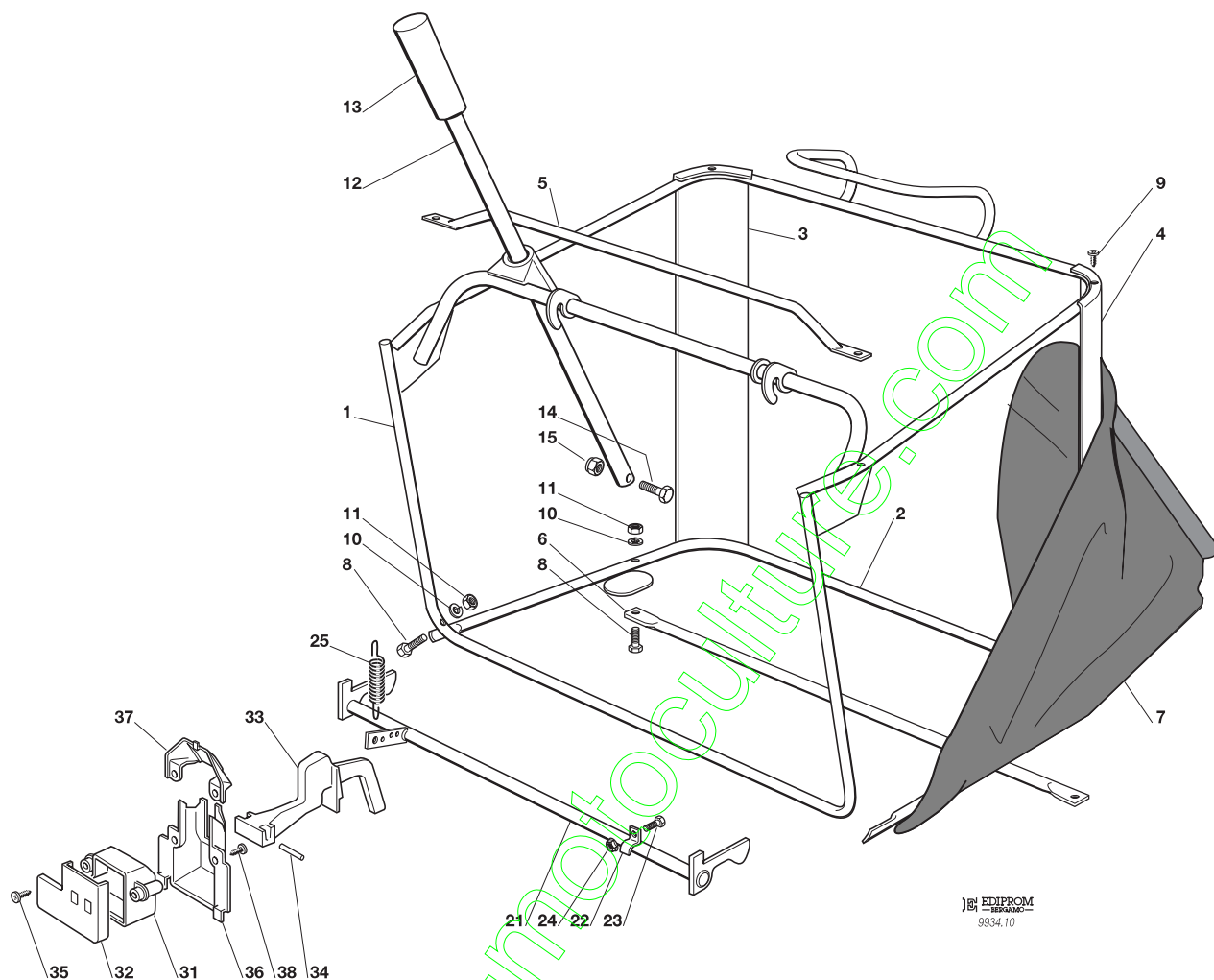

EDIPROM
9934.10

N.	CODE	Q.TY	DESCRIZIONE	DESCRIPTION	DESCRIPTION	BESCHREIBUNG
1	82800043/0	1	TELAIO SUPERIORE	UPPER FRAME	CHASSIS SUPERIEUR	OBERERRAHMEN
2	82800002/1	1	TELAIO INFERIORE	LOWER FRAME	CHASSIS INFERIEUR	UNTERERRAHMEN
3	25032001/1	1	ANGOLARE DESTRO	RIGHT ANGULAR SUPPORT	SUPPORT ANG. DROITE	RECHTER HALTER
4	25032002/1	1	ANGOLARE SINISTRO	LEFT ANGULAR SUPPORT	SUPPORT ANG. GAUCHE	LINKER HALTER
5	82394001/1	1	MANIGLIA ANTERIORE	FRONT HANDLE	POIGNEE ANTERIEURE	VORDERGRIFF
6	82650038/0	1	RINFORZO INFERIORE	LOWER STIFFENING	RENFORCEMENT SUPER.	OBERE VERSTAERKUNG
7	82106000/2	1	SACCO	GRASSCATCHER	SAC	SACK
8	12792099/0	2	VITE	SCREW	VIS	SCHRAUBE
9	12729601/0	4	VITE	SCREW	VIS	SCHRAUBE
10	12582101/0	2	GROWER	GROWER	GROWER	GROWER
11	12292100/0	2	DADO	NUT	ECROU	MUTTER
12	25869029/1	1	TUBO	ROD	TIGE	STANGE
13	25394508/0	1	MANOPOLA	HANDLE	POINGEE	GRIFF
14	12792099/0	1	VITE	SCREW	VIS	SCHRAUBE
15	12154510/0	1	DADO	NUT	ECROU	MUTTER
21	82000483/0	1	ASTA AGGANCIAMENTO SACCO	COUPLING ROD	TIGE D'ACCROCHAGE	KUPPLUNGSTANGE
22	25774220/0	2	STAFFA ANCORAGGIO	ANCHOR BRACKET	ETRIER	BRIDE
23	12791200/0	2	VITE	SCREW	VIS	SCHRAUBE
24	12292102/0	2	DADO	NUT	ECROU	MUTTER
25	25430210/0	1	MOLLA	SPRING	RESSORT	FEDER
31	25600041/0	1	PROTEZIONE MICRO	MICRO PROTECTION	PROTECTION MICRO	SCHUTZ
32	25600042/0	1	COPERCHIO PROTEZIONE	PROTECTION COVER	COUVERCLE PROTECTION	SCHUTZDEKEL
33	25318124/0	1	LEVA	LEVER	LEVIER	HEBEL
34	12400030/0	1	SPINA	PIN	GOUPILLE	STIFT
35	12728510/0	2	VITE	SCREW	VIS	SCHRAUBE
36	25600047/0	1	PROTEZIONE MICRO	MICRO PROTECTION	PROTECTION MICRO	SCHUTZ
37	25600048/0	1	COPERCHIO PROTEZIONE	PROTECTION COVER	COUVERCLE PROTECTION	SCHUTZDEKEL
38	12728450/0	2	VITE	SCREW	VIS	SCHRAUBE

TC102 hy. TCP102 hy. TCR102 hy.

TC122 hy. TCP122 hy. TCR122 hy.

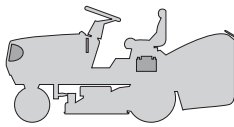

PARTI ELETTRICHE
ELECTRICAL PARTS
PARTIES ELECTRIQUES
ELETRISCHE TEILE

2000

011.0

1 / 2

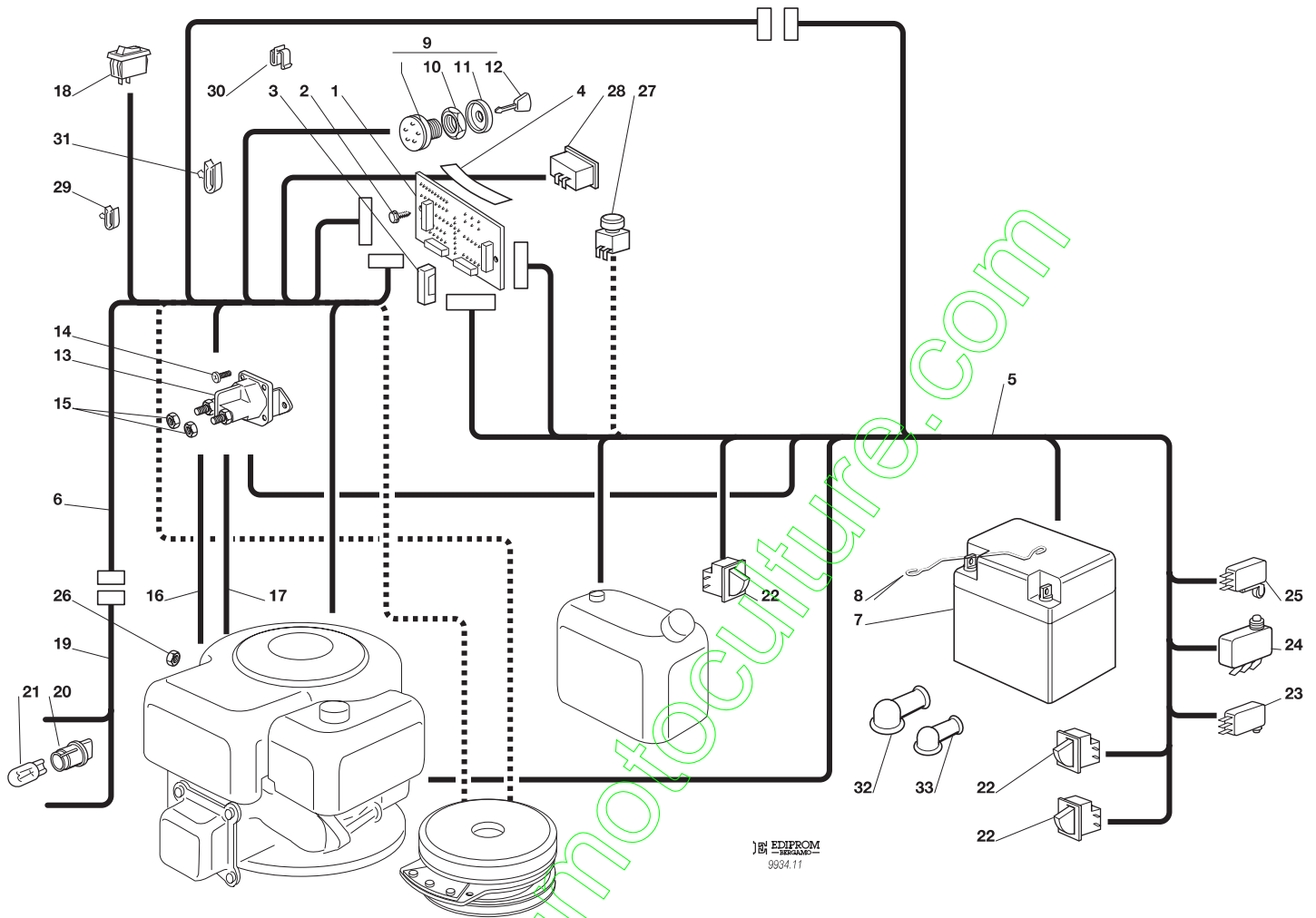

N.	CODE	Q.TY	DESCRIZIONE	DESCRIPTION	DESCRIPTION	BESCHREIBUNG
2	12735105/0	3	VITE	SCREW	VIS	SCHRAUBE
3	33340033/0	1	FUSIBILE	FUSE	FUSIBLE	SICHERUNG
4	25420004/0	1	MEMBRANA (6 FUNZIONI)	CHECK CONTROL (6 FUNCTIONS)	PANNEAU DE CONTROLE (6 INDICATIONS)	KONTROLLTAFEL (6 ANGABEN)
	25420005/0	1	MEMBRANA (8 FUNZIONI)	CHECK CONTROL (8 FUNCTIONS)	PANNEAU DE CONTROLE (8 INDICATIONS)	KONTROLLTAFEL (8 ANGABEN)
5	82040058/0	1	CABLAGGIO POSTERIORE 12,5 - 13 HP B&S	CABLES ASS.Y 12,5 - 13 HP B&S	ENS. CABLAGES 12,5 - 13 HP B&S	KABELSATZ 12,5 - 13 HP B&S
	82040065/0		13 - 15 HP TECUMSEH	13 - 15 HP TECUMSEH	13 - 15 HP TECUMSEH	13 - 15 HP TECUMSEH
	82040059/0		15 - 15,5 - 17 HP B&S	15 - 15,5 - 17 HP B&S	15 - 15,5 - 17 HP B&S	15 - 15,5 - 17 HP B&S
			18 - 20 HP B&S	18 - 20 HP B&S	18 - 20 HP B&S	18 - 20 HP B&S
6	82040060/0	1	CABLAGGIO ANTERIORE 12,5 - 13 HP B&S (senza contaore)	CABLES ASS.Y 12,5 - 13 HP B&S (without hour counter)	ENS. CABLAGES 12,5 - 13 HP B&S (sans compte-heurs)	KABELSATZ 12,5 - 13 HP B&S (ohne betriebsstundenzähler)
	82040066/0		13 - 15 HP TECUMSEH 12,5 - 13 HP B&S (con contaore)	13 - 15 HP TECUMSEH 12,5 - 13 HP B&S (with hour counter)	13 - 15 HP TECUMSEH 12,5 - 13 HP B&S (avec compte-heurs)	13 - 15 HP TECUMSEH 12,5 - 13 HP B&S (mit betriebsstundenzähler)
	82040061/0		15 - 15,5 - 17 HP B&S 18 - 20 HP B&S	15 - 15,5 - 17 HP B&S 18 - 20 HP B&S	15 - 15,5 - 17 HP B&S 18 - 20 HP B&S	15 - 15,5 - 17 HP B&S 18 - 20 HP B&S
7	18120002/1	1	BATTERIA	BATTERY	BATTERIE	BATTERIE
8	25430230/0	1	MOLLA	SPRING	RESSORT	FEDER
9	18450065/1	1	INTERRUTTORE AVVIAM.	STARTING SWITCH	INTERRUPTEUR DEMARR.	SCHALTER
10	18400861/0	1	GHIERA	RINGNUT	EMBOUT	NUTMUTTER
11	18565351/0	1	PROTEZIONE GHIERA	RINGNUT PROTECTION	PROTECTION EMBOUT	NUTMUTTER SCHUTZ
12	18210016/0	1	CHIAVE AVVIAMENTO	STARTING KEY	CLEF A DEMARRAGE	SCHLÜSSEL FÜR START
13	18736111/0	1	RELÉ AVVIAMENTO	STARTER RELAY	RELAIS D'ALLUMAGE	ANLASSRELAIS
14	12791213/0	2	VITE	SCREW	VIS	SCHRAUBE
15	12360352/0	2	DADO	NUT	ECROU	MUTTER
16	25065002/0	1	CAVO SOLEN. AVV.	CABLES ASS.Y	ENS. CABLAGES	KABELSATZ
17	25065003/0	1	CAVO RICARICA	CABLE	CABLES	KABEL
18	18450060/1	1	INTERRUTTORE	FARILAMP SWITCH	INTERRUPTEUR PHARES	LICHTEN SCHALTER



N.	CODE	Q.TY	DESCRIZIONE	DESCRIPTION	DESCRIPTION	BESCHREIBUNG
19	82040063/0	1	CABLAGGIO LAMPADE	CABLE	CABLES	KABEL
20	33500030/0	2	PORTALAMPADE	LAMP HOLDER	DOUILLE DE LAMPE	SCHEINWERFERLAMPE
21	18459100/0	2	LAMPADA	FARILAMP FOR LIGHTS	LAMPE POUR PHARES	LAMPENFASSUN
23	19410605/1	1	MICRO SACCO PIENO	FULL GRASSCAT. MICROSW.	MICRO BAC PLEIN	VOLLKORB VORRICHTUNG
24	19410603/1	1	MICRO SEDILE	MICRO	MICRO	MIKRO
25	19410609/0	1	MICRO FOLLE	NEUTRAL SWITCH	MICROINT. POINT MORT	LEERLAUF MIKROSCHALTER
26	12361005/0	1	DADO	NUT	ECROU	MUTTER
28	18230000/0	1	CONTAORE	HOUR COUNTER	COMPTE-HEURS	BETRIEBSSTUNDEZÄHLER
29	33320506/0	1	FERMACAVO	FAIRLED	FIXATION CABLE	KABELBEFESTIGUNG
30	33320504/0	1	FERMACAVO	FAIRLED	FIXATION CABLE	KABELBEFESTIGUNG
31	33320505/0	1	FERMACAVO	FAIRLED	FIXATION CABLE	KABELBEFESTIGUNG
32	18564861/0	1	CAPPUCCIO	PROTECTION	CAPUCHON	STECKER
33	18564862/0	1	CAPPUCCIO	PROTECTION	CAPUCHON	STECKER

Nei modelli con innesto delle lame a leva:

For models with engagement of the blades by lever:

Dans les modèles avec embrayage des lames à levier:

Bei Modellen mit Hebelschaltung der Messer:

1	27522412/0	1	SCHEDA ELETTRONICA	ELECTRONIC CARD	CARTE ELECTRONIQUE	ELEKTRONISCHE KARTE
22	19410606/0	3	MICRO INTERRUTTORE	MICRO	MICRO	MIKRO

Nei modelli con innesto delle lame elettromagnetico:

For models with engagement of the blades by electromagnetic clutch:

Dans les modèles avec embrayage des lames électromagnétique:

Bei Modellen mit elektromagnetischer Schaltung der Messer:

1	27522413/0	1	SCHEDA ELETTRONICA	ELECTRONIC CARD	CARTE ELECTRONIQUE	ELEKTRONISCHE KARTE
22	19410606/0	2	MICRO INTERRUTTORE	MICRO	MICRO	MIKRO
27	18450067/0	1	INTERRUTTORE FRIZIONE	CLUTCH SWITCH	INTERRUPTEUR EMBRAJAGE	KUPPLUNG SCHALTER

www.emc-motoculture.com

TC102 hy. TCP102 hy. TCR102 hy.

TC122 hy. TCP122 hy. TCR122 hy.

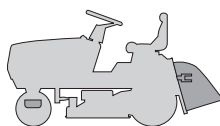

ACCESSORI A RICHIESTA
OPTIONALS ON REQUEST
ACCESSOIRES SUR DEMANDE
ZUBEHOERE NACH ANFRAGE

1999

012.0

1 / 1

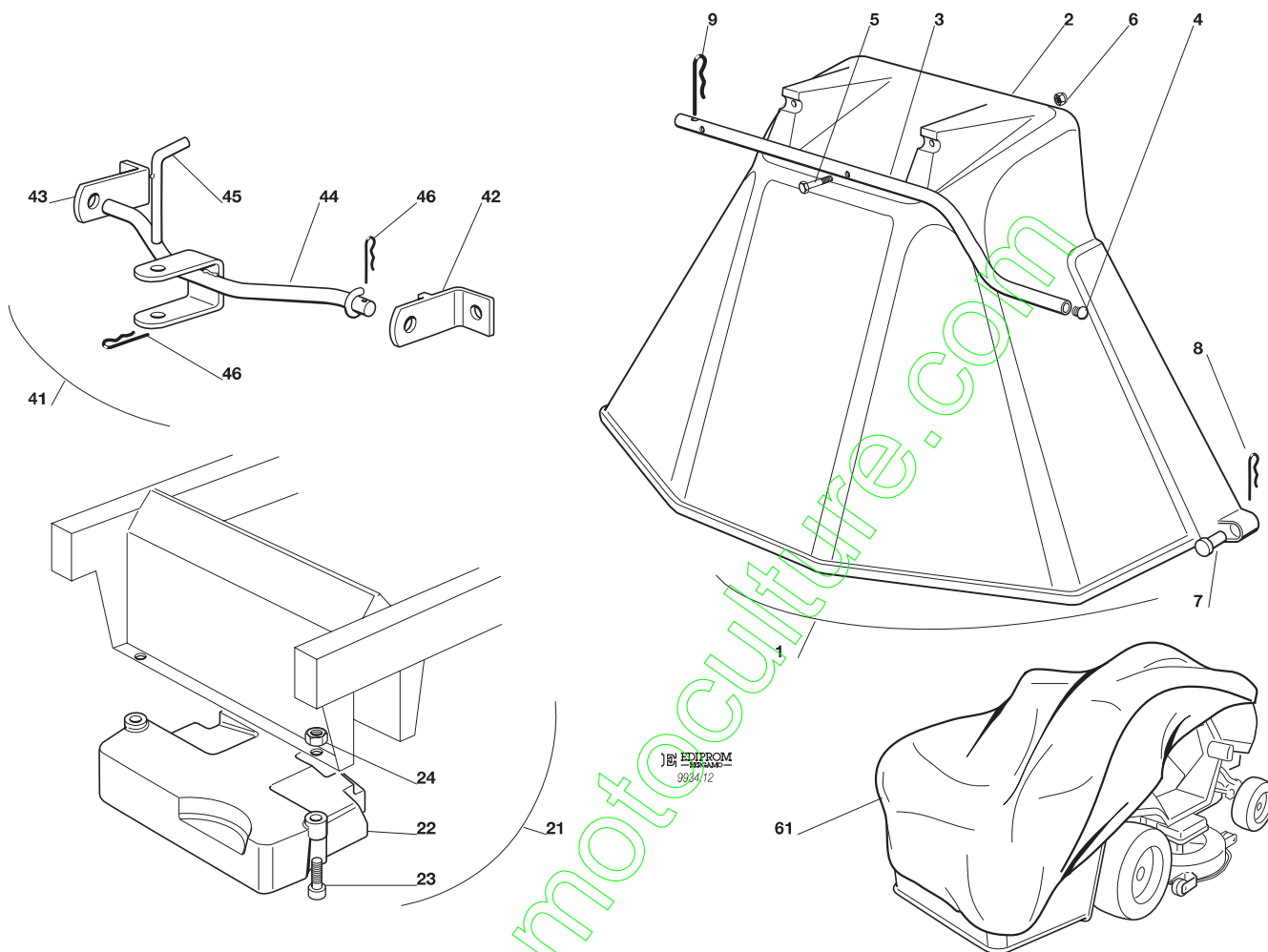

N.	CODE	Q.TY	DESCRIZIONE	DESCRIPTION	DESCRIPTION	BESCHREIBUNG
1	99900015/0	1	ASS. KIT PROTEZIONE USCITA	EJECTION-GUARD ASS.Y	KIT PROTECTION SORTIE	VORRICHTUNG FÜR AUSWURESCHUTZ
2	82400003/0	1	PROTEZIONE USCITA	EJECTION GUARD	PROTECTION SORTIE	AUSWURFSCHUTZ
3	25869043/0	1	TUBO DI AGGANCIO	SUPPORT	SOPPORT	HALTER
4	18566110/0	2	PUNTALE	CAP	BOUCHON	PFROPFEN
5	12689515/0	2	VITE	SCREW	VIS	SCHRAUBE
6	12154510/0	2	DADO	NUT	ECROU	MUTTER
7	25510022/0	2	PERNO	PIN	PIVOT	BOLZEN
8	24487998/0	2	COPPIGLIA	COTTER PIN	GOUPILLE	SPLIT
9	24487999/0	1	COPPIGLIA	COTTER PIN	GOUPILLE	SPLIT
21	99900030/5	1	ASS. KIT PESO ANT.	FRONT WEIGHT KIT	KIT POIDS ANTERIEUR	VORDERGEWICHT VORRICHTUNG
22	25519997/0	1	PESO	WEIGHT	POIDS	GEWICHT
23	12760520/0	3	VITE	SCREW	VIS	SCHRAUBE
24	12155000/0	3	DADO	NUT	ECROU	MUTTER
41	99900005/0	1	ASS. KIT TRAINO	HITCH KIT	KIT DE TRAINAGE	ZUGVORRICHTUNG
42	82735502/0	1	STAFFA SUPPORTO TRAINO DX	BRACKET RIGHT HITCH SUPPORT	ETRIER SUPPORT TRAINAGE DROITE	BUEGEL HALTER FÜR RECHTEN ZUG
43	25774213/0	1	STAFFA SUPPORTO TRAINO SX	BRACKET LEFT HITCH SUPPORT	ETRIER SUPPORT TRAINAGE GAUCHE	BUEGELHALTER FÜR LINKEN ZUG
44	82033105/0	1	BARRA	ROD	BARRE	STANGE
45	25510021/0	1	PERNO	PIN	PIVOT	BOLZEN
46	24487999/0	2	COPPIGLIA	COTTER PIN	GOUPILLE	SPLIT
51	18737950/0	1	TELO DI COPERTURA	CLOTH	BÂCHE	PLANE

TC102 hy. TCP102 hy. TCR102 hy.

TC122 hy. TCP122 hy. TCR122 hy.

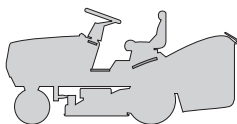

ETICHETTE
LABELS
ETIQUETTES
KLEBZETTEL

2000

013.0

1 / 1

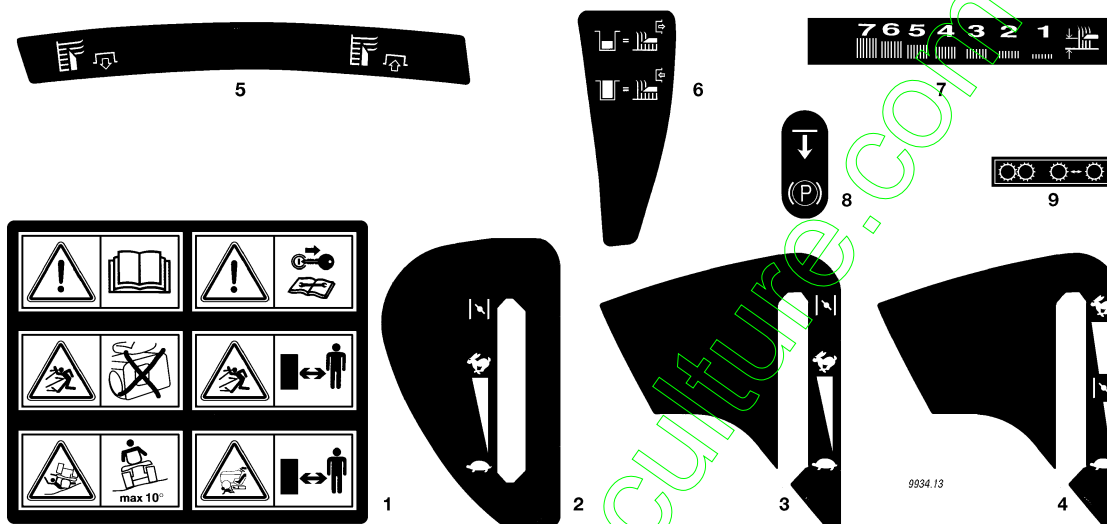

N.	CODE	Q.TY	DESCRIZIONE	DESCRIPTION	DESCRIPTION	BESCHREIBUNG
1	14357190/0	1	ETICHETTA	LABEL	ETIQUETTE	KLEBZETTEL
2	14356754/1	1	ETICHETTA (TCP)	LABEL (TCP)	ETIQUETTE (TCP)	KLEBZETTEL (TCP)
3	14356177/2	1	ETICHETTA (TC - TCR)	LABEL (TC - TCR)	ETIQUETTE (TC - TCR)	KLEBZETTEL (TC - TCR)
4	14357184/2	1	ETICHETTA (TC - TCR)	LABEL (TC - TCR)	ETIQUETTE (TC - TCR)	KLEBZETTEL (TC - TCR)
7	14357905/0	1	ETICHETTA	LABEL	ETIQUETTE	KLEBZETTEL
8	14357526/0	1	ETICHETTA	LABEL	ETIQUETTE	KLEBZETTEL
9	14357423/1	1	ETICHETTA	LABEL	ETIQUETTE	KLEBZETTEL
			<i>Nei modelli con innesto delle lame a leva:</i>	<i>For models with engagement of the blades by lever:</i>	<i>Dans les modèles avec embrayage des lames à levier:</i>	<i>Bei Modellen mit Hebelschaltung der Messer:</i>
5	14357906/0	1	ETICHETTA	LABEL	ETIQUETTE	KLEBZETTEL
			<i>Nei modelli con innesto delle lame elettromagnetico:</i>	<i>For models with engagement of the blades by electromagnetic clutch:</i>	<i>Dans les modèles avec embrayage des lames électromagnétique:</i>	<i>Bei Modellen mit elektromagnetischer Schaltung der Messer:</i>
6	14357967/0	1	ETICHETTA	LABEL	ETIQUETTE	KLEBZETTEL

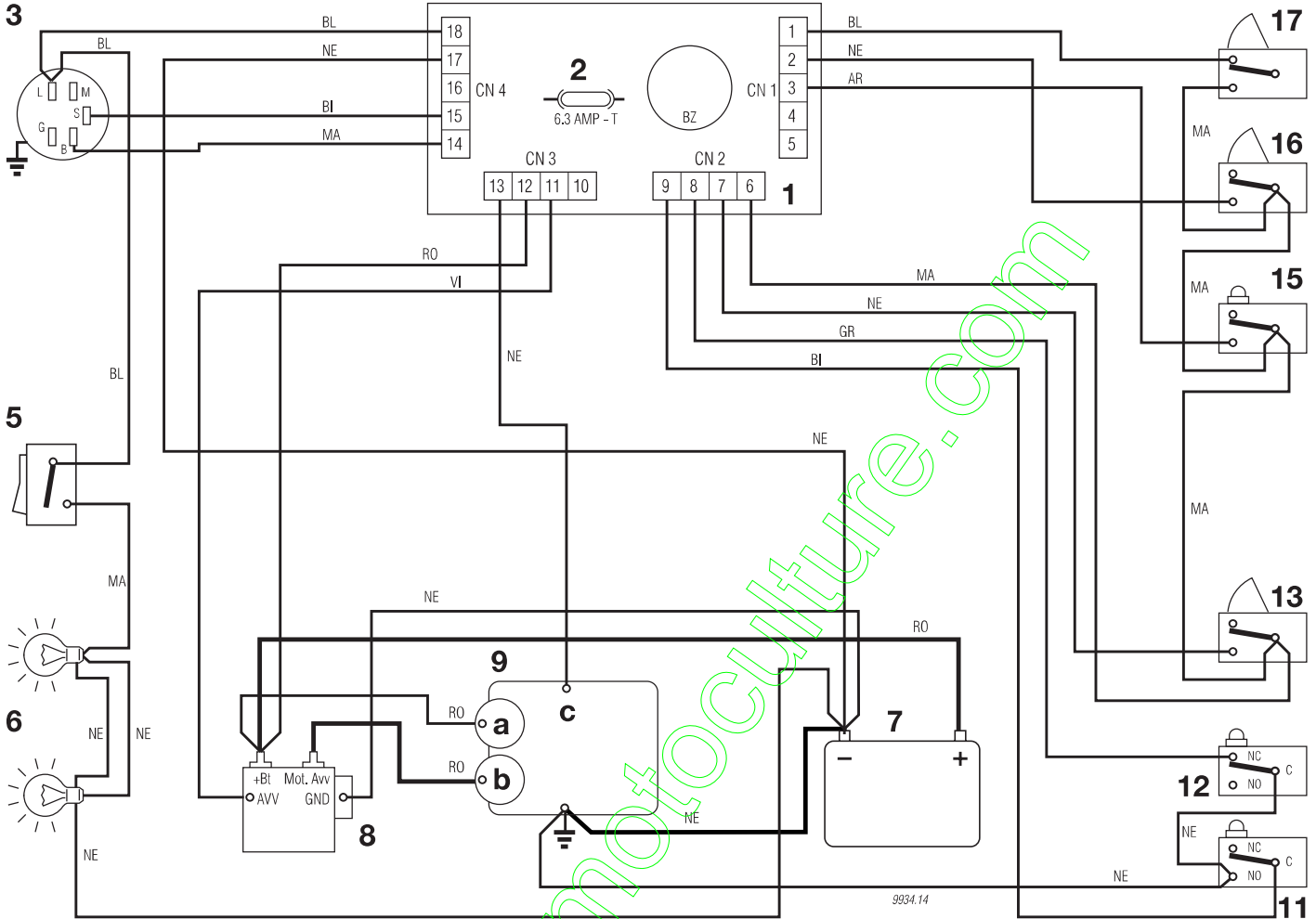

- | | | | |
|-----------------------------------------|--------------------------------|--------------------------|-------------------------|
| 1 SCHEDA | ELECTRONIC CARD | CARTE ELECTRONIQUE | ELECTRONISCHE KARTE |
| 2 FUSIBILE 6,3 Amp. T | FUSE 6,3 Amp. T | FUSIBLE 6,3 Amp. T | SICHERUNG 6,3 Amp. T |
| 3 INTERRUOTTORE A CHIAVE | ELECTROLOCK | INTERRUPTEUR D'ALLUMAGE | SCHLÜSSELSCHALTER |
| 5 INTERRUOTTORE FARI | HEADLIGHT SWITCH | INTERRUPTEUR PHARES | LICHTSCHALTER |
| 6 FARI | HEADLIGHT | PHARES | LICHT |
| 7 BATTERIA | BATTERY | BATTERIE | BATTERIE |
| 8 RELE AVVIAMENTO | STARTER RELAY | RELAIS DE DEMARRAGE | ANLASSER RELAIS |
| 9 MOTORE | ENGINE | MOTEUR | MOTOR |
| 9a Generatore | Generator | Generateur | Generator |
| 9b Motorino avviamento | Starter | Demarreur | Anlasser |
| 9c Stop motore | Engine stop | Calage du moteur | Motor abstellung |
| 11 MICROINTERRUPTORE SACCO PIENO | FULL GRASSCATCHER MICRO SWITCH | MICRO BAC PLEIN | VOLLKORB VORRICHTUNG |
| 12 MICROINTERRUPTORE FOLLE | NEUTRAL MICROSWITCH | MICRO INT. POINT MORT | LEERLAUF MICROSCHALTER |
| 13 MICROINTERRUPTORE SACCO | GRASSCATCHER MICRO SWITCH | MICRO INTERRUPTEUR BAC | GRASFANG. MIKROSCHALTER |
| 14 SERBATOIO | TANK | RESERVOIRE | TANK |
| 15 MICROINTERRUPTORE SEDILE | SEAT MICRO SWITCH | MICRO INTERRUPTEUR SIEGE | SITZMIKROSCHALTER |
| 16 MICROINTERRUPTORE FRENO | BRAKE MICRO SWITCH | MICRO INTERRUPTEUR FREIN | BREMSE MIKROSCHALTER |
| 17 MICROINTERRUPTORE LAME | BLADES MICRO SWITCH | MICRO INTERRUPTEUR LAMES | MESSER MIKROSCHALTER |

COLORI CAVI	CABLE COLOURS	COULEUR CABLES	KABEL FARBEN
AR ARANCIONE	ORANGE	ORANGE	ORANGE
BI BIANCO	WHITE	BLANC	WEISS
BL BLU	BLUE	BLEU	BLAU
GI GIALLO	YELLOW/GREEN	JAUNE/VERT	GELB/GRÜN
GR GRIGIO	GREY	GRIS	GRAU
MA MARRONE	BROWN	BRUN	BRAUN
NE NERO	BLACK	NOIR	SCHWARZ
RO ROSSO	RED	ROUGE	ROT
VI VIOLA	VIOLET	VIOLET	VIOLETT

TC102 hy. TCP102 hy. TCR102 hy.

TC122 hy. TCP122 hy. TCR122 hy.

SCHEMA ELETTRICO (innesto a leva)
WIRE DIAGRAM (engagement by lever)
SCHEMA ELECTRIQUE (embrayage à levier)
ELEKTRISCHE SCHEMA (Hebelschaltung)
15 - 15,5 - 17 HP B&S

2000

014a.0

1 / 1

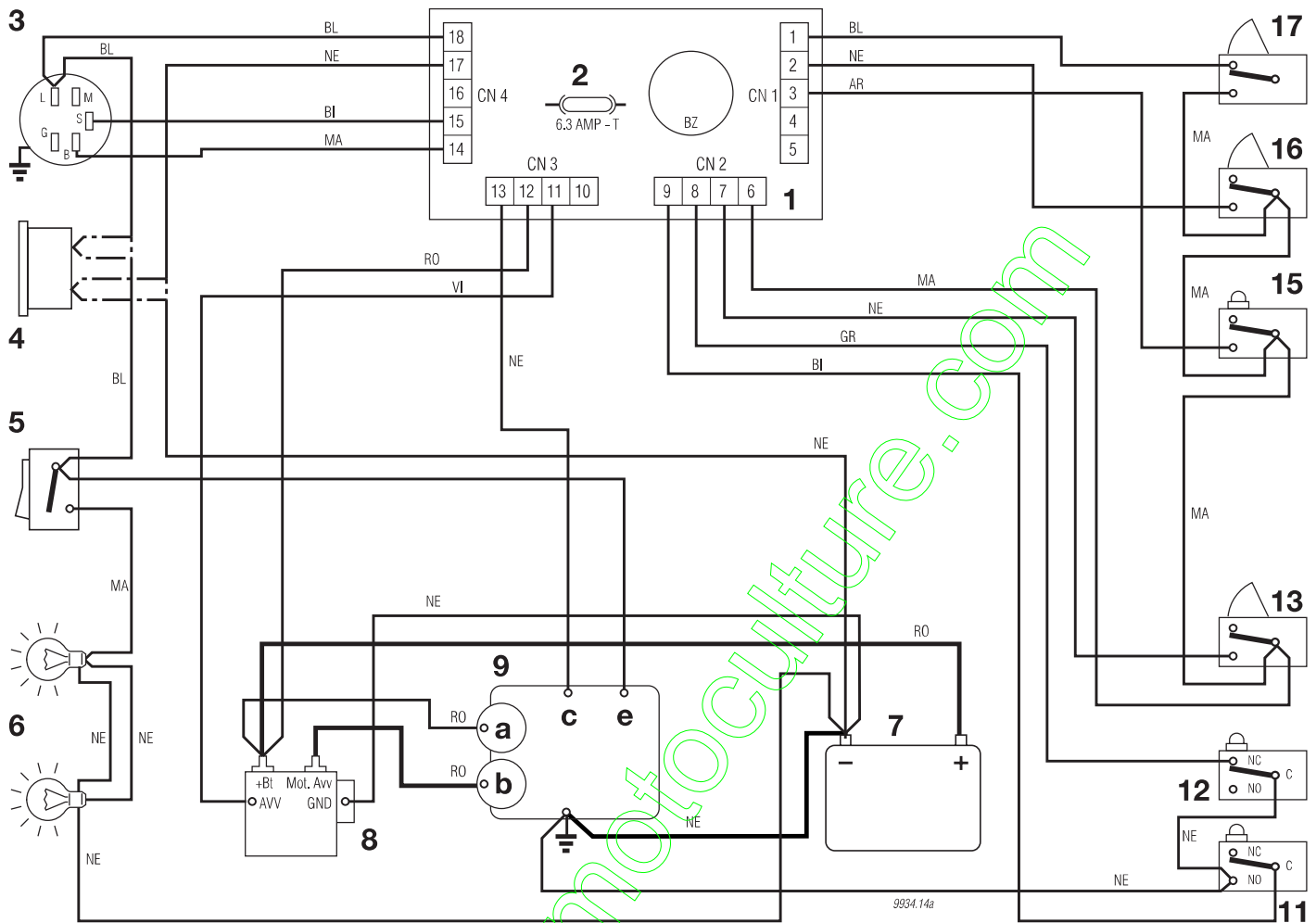

- | | | | |
|-----------------------------------------|--------------------------------|--------------------------|------------------------------|
| 1 SCHEDA | ELECTRONIC CARD | CARTE ELECTRONIQUE | ELECTRONISCHE KARTE |
| 2 FUSIBILE 6,3 Amp. T | FUSE 6.3 Amp. T | FUSIBLE 6,3 Amp. T | SICHERUNG 6,3 Amp. T |
| 3 INTERRUPTORE A CHIAVE | ELECTROLOCK | INTERRUPTEUR D'ALLUMAGE | SCHLÜSSELSCHALTER |
| 4 CONTAORE (TCP) | HOUR COUNTER (TCP) | COMPTE-HEURS (TCP) | BETRIEBESSTUNDENZÄHLER (TCP) |
| 5 INTERRUPTORE FARI | HEADLIGHT SWITCH | INTERRUPTEUR PHARES | LICHTSCHALTER |
| 6 FARI | HEADLIGHT | PHARES | LICHT |
| 7 BATTERIA | BATTERY | BATTERIE | BATTERIE |
| 8 RELE AVVIAMENTO | STARTER RELAY | RELAIS DE DEMARRAGE | ANLASSER RELAIS |
| 9 MOTORE | ENGINE | MOTEUR | MOTEUR |
| 9a Generatore | Generator | Generateur | Generator |
| 9b Motorino avviamento | Starter | Demarreur | Anlasser |
| 9c Stop motore | Engine stop | Calage du moteur | Motor abstellung |
| 9e Carburatore | Carburator | Carburateur | Vergaser |
| 11 MICROINTERRUPTORE SACCO PIENO | FULL GRASSCATCHER MICRO SWITCH | MICRO BAC PLEIN | VOLLKORB VORRICHTUNG |
| 12 MICROINTERRUPTORE FOLLE | NEUTRAL MICROSCHITCH | MICRO INT. POINT MORT | LEERLAUF MICROSCHALTER |
| 13 MICROINTERRUPTORE SACCO | GRASSCATCHER MICRO SWITCH | MICRO INTERRUPTEUR BAC | GRASFANG. MIKROSCHALTER |
| 15 MICROINTERRUPTORE SEDILE | SEAT MICRO SWITCH | MICRO INTERRUPTEUR SIEGE | SITZMIKROSCHALTER |
| 16 MICROINTERRUPTORE FRENO | BRAKE MICRO SWITCH | MICRO INTERRUPTEUR FREIN | BREMSE MIKROSCHALTER |
| 17 MICROINTERRUPTORE LAME | BLADES MICRO SWITCH | MICRO INTERRUPTEUR LAMES | MESSER MIKROSCHALTER |

COLORI CAVI

- AR** ARANCIONE
- BI** BIANCO
- BL** BLU
- GI** GIALLO
- GR** GRIGIO
- MA** MARRONE
- NE** NERO
- RO** ROSSO
- VI** VIOLA

CABLE COLOURS

- ORANGE
- WHITE
- BLUE
- YELLOW/GREEN
- GREY
- BROWN
- BLACK
- RED
- VIOLET

COULEUR CABLES

- ORANGE
- BLANC
- BLEU
- JAUNE/VERT
- GRIS
- BRUN
- NOIR
- ROUGE
- VIOLET

KABEL FARBEN

- ORANGE
- WEISS
- BLAU
- GELB/GRÜN
- GRAU
- BRAUN
- SCHWARZ
- ROT
- VIOLETT

TC102 hy.	TCP102 hy.	TCR102 hy.
TC122 hy.	TCP122 hy.	TCR122 hy.

SCHEMA ELETTRICO (innesto a leva)
WIRE DIAGRAM (engagement by lever)
SCHEMA ELECTRIQUE (embrayage à levier)
ELEKTRISCHE SCHEMA (Hebelschaltung)
18 - 20 HP B&S

2000
014b.0
1 / 1

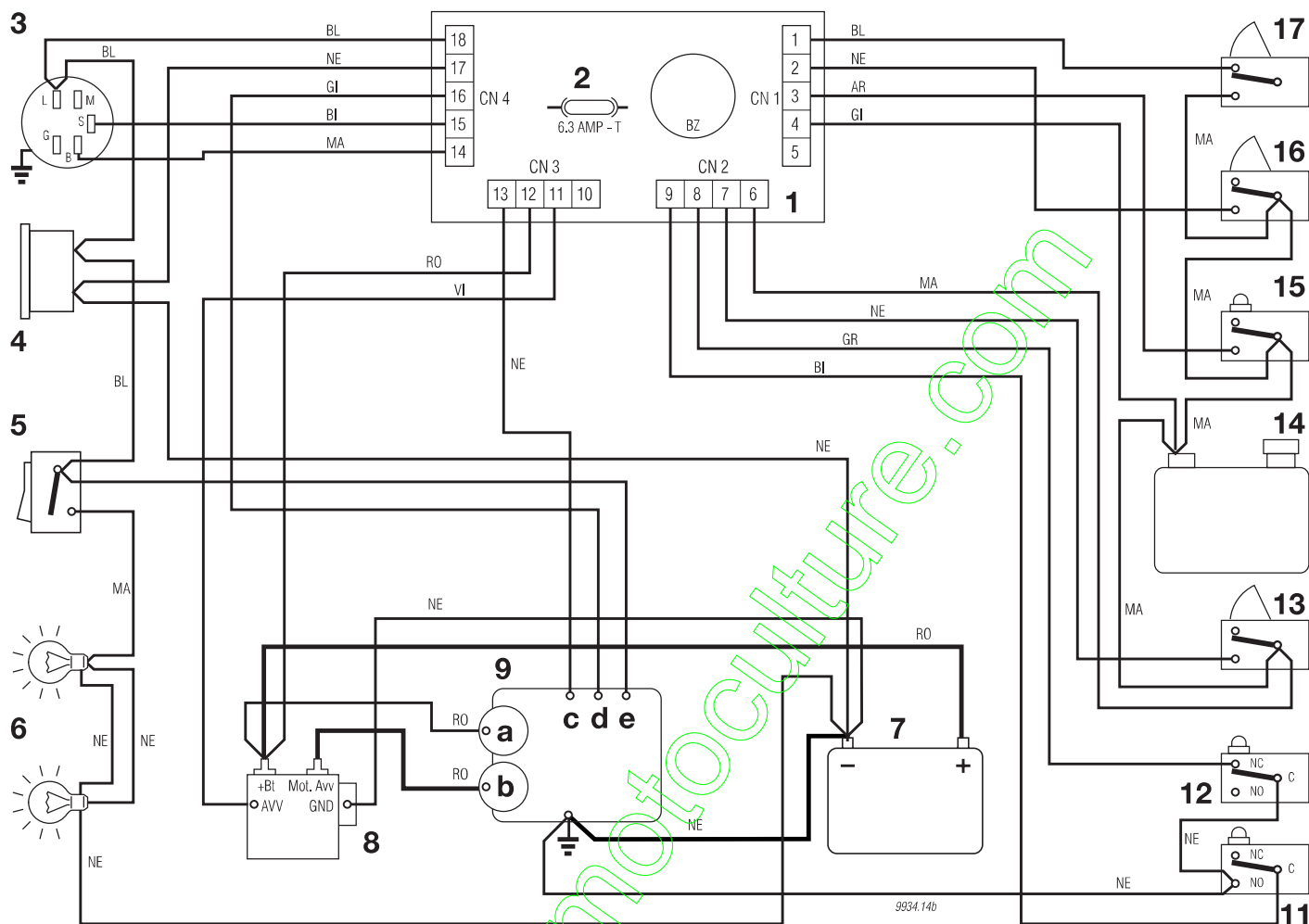

- | | | | |
|-----------------------------------------|--------------------------------|--------------------------|-------------------------|
| 1 SCHEDA | ELECTRONIC CARD | CARTE ELECTRONIQUE | ELECTRONISCHE KARTE |
| 2 FUSIBILE 6,3 Amp. T | FUSE 6.3 Amp. T | FUSIBLE 6,3 Amp. T | SICHERUNG 6,3 Amp. T |
| 3 INTERRUOTTORE A CHIAVE | ELECTROLOCK | INTERRUPTEUR D'ALLUMAGE | SCHLÜSSELSCHALTER |
| 4 CONTAORE | HOUR COUNTER | COMPTE-HEURS | BETRIEBESSTUNDENZÄHLER |
| 5 INTERRUOTTORE FARI | HEADLIGHT SWITCH | INTERRUPTEUR PHARES | LICHTSCHALTER |
| 6 FARI | HEADLIGHT | PHARES | LICHT |
| 7 BATTERIA | BATTERY | BATTERIE | BATTERIE |
| 8 RELE AVVIAMENTO | STARTER RELAY | RELAIS DE DEMARRAGE | ANLASSER RELAIS |
| 9 MOTORE | ENGINE | MOTEUR | MOTOR |
| 9a Generatore | Generator | Generateur | Generator |
| 9b Motorino avviamento | Starter | Demarreur | Anlasser |
| 9c Stop motore | Engine stop | Calage du moteur | Motor abstellung |
| 9d Olio | Oil | Huile | Öl |
| 9e Carburatore | Carburator | Carburateur | Vergaser |
| 11 MICROINTERRUPTORE SACCO PIENO | FULL GRASSCATCHER MICRO SWITCH | MICRO BAC PLEIN | VOLLKORB VORRICHTUNG |
| 12 MICROINTERRUPTORE FOLLE | NEUTRAL MICROSWITCH | MICRO INT. POINT MORT | LEERLAUF MICROSCHALTER |
| 13 MICROINTERRUPTORE SACCO | GRASSCATCHER MICRO SWITCH | MICRO INTERRUPTEUR BAC | GRASFANG. MIKROSCHALTER |
| 14 SERBATOIO | TANK | RESERVOIRE | TANK |
| 15 MICROINTERRUPTORE SEDILE | SEAT MICRO SWITCH | MICRO INTERRUPTEUR SIEGE | SITZMIKROSCHALTER |
| 16 MICROINTERRUPTORE FRENO | BRAKE MICRO SWITCH | MICRO INTERRUPTEUR FREIN | BREMSE MIKROSCHALTER |
| 17 MICROINTERRUPTORE LAME | BLADES MICRO SWITCH | MICRO INTERRUPTEUR LAMES | MESSER MIKROSCHALTER |

COLORI CAVI	CABLE COLOURS	COULEUR CABLES	KABEL FARBEN
AR ARANCIONE	ORANGE	ORANGE	ORANGE
BI BIANCO	WHITE	BLANC	WEISS
BL BLU	BLUE	BLEU	BLAU
GI GIALLO	YELLOW/GREEN	JAUNE/VERT	GELB/GRÜN
GR GRIGIO	GREY	GRIS	GRAU
MA MARRONE	BROWN	BRUN	BRAUN
NE NERO	BLACK	NOIR	SCHWARZ
RO ROSSO	RED	ROUGE	ROT
VI VIOLA	VIOLET	VIOLET	VIOLETT

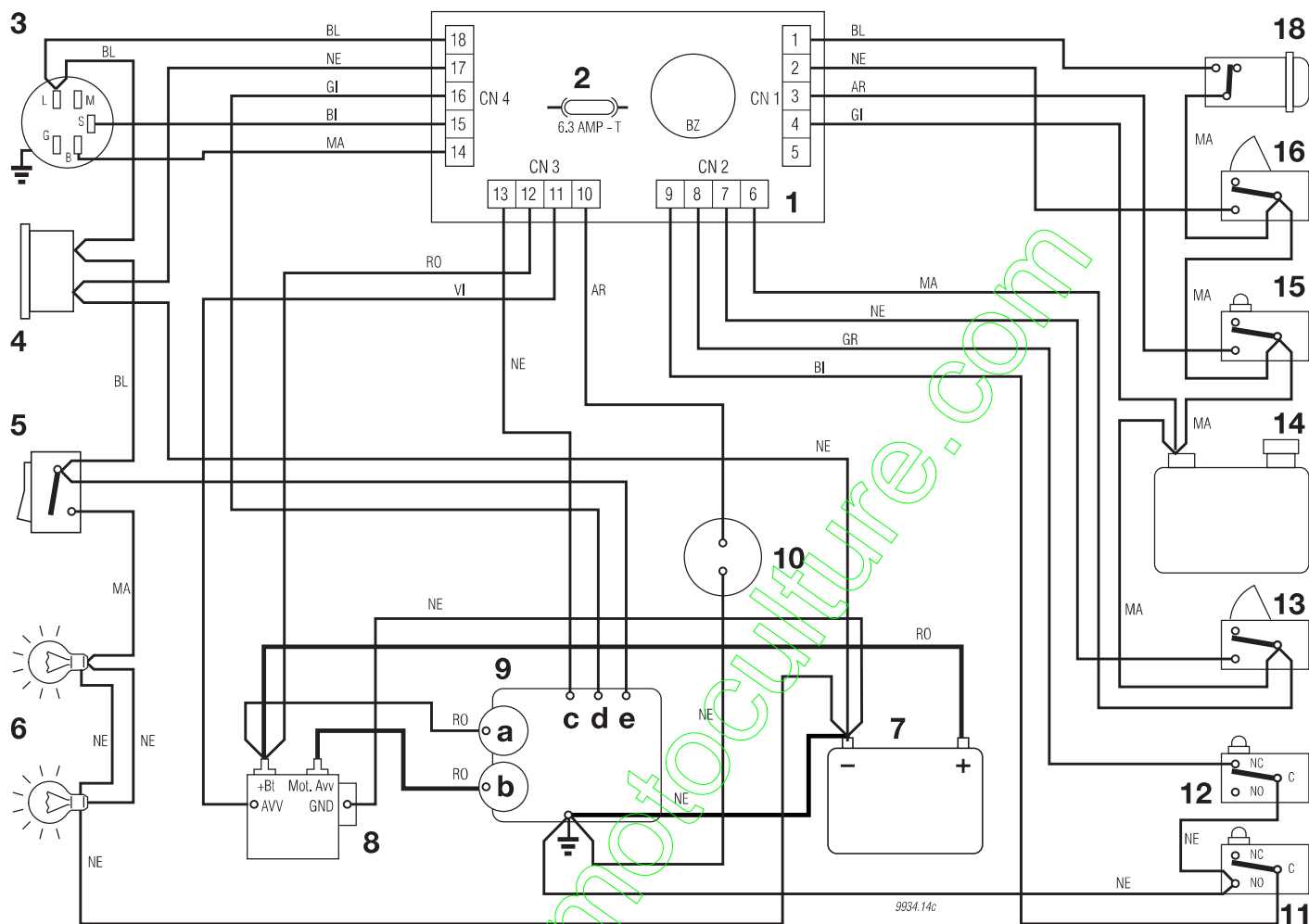

- | | | | |
|-----------------------------------------|--------------------------------|--------------------------|-------------------------|
| 1 SCHEDA | ELECTRONIC CARD | CARTE ELECTRONIQUE | ELECTRONISCHE KARTE |
| 2 FUSIBILE 6,3 Amp. T | FUSE 6.3 Amp. T | FUSIBLE 6,3 Amp. T | SICHERUNG 6,3 Amp. T |
| 3 INTERRUTTORE A CHIAVE | ELECTROLOCK | INTERRUPTEUR D'ALLUMAGE | SCHLÜSSELSCHALTER |
| 4 CONTAORE | HOUR COUNTER | COMPTE-HEURS | BETRIEBESSTUNDENZÄHLER |
| 5 INTERRUTTORE FARI | HEADLIGHT SWITCH | INTERRUPTEUR PHARES | LICHTSCHALTER |
| 6 FARI | HEADLIGHT | PHARES | LICHT |
| 7 BATTERIA | BATTERY | BATTERIE | BATTERIE |
| 8 RELE AVVIAMENTO | STARTER RELAY | RELAIS DE DEMARRAGE | ANLASSER RELAIS |
| 9 MOTORE | ENGINE | MOTEUR | MOTEUR |
| 9a Generatore | Generator | Generateur | Generator |
| 9b Motorino avviamento | Starter | Demarreur | Anlasser |
| 9c Stop motore | Engine stop | Calage du moteur | Motor abstellung |
| 9d Olio | Oil | Huile | Öl |
| 9e Carburatore | Carburator | Carburateur | Vergaser |
| 10 FRIZIONE | CLUTCH | EMBRAJAGE | KUPPLUNG |
| 11 MICROINTERRUTTORE SACCO PIENO | FULL GRASSCATCHER MICRO SWITCH | MICRO BAC PLEIN | VOLLKORB VORRICHTUNG |
| 12 MICROINTERRUTTORE FOLLE | NEUTRAL MICROSWITCH | MICRO INT. POINT MORT | LEERLAUF MICROSCHALTER |
| 13 MICROINTERRUTTORE SACCO | GRASSCATCHER MICRO SWITCH | MICRO INTERRUPTEUR BAC | GRASFANG. MIKROSCHALTER |
| 14 SERBATOIO | TANK | RESERVOIRE | TANK |
| 15 MICROINTERRUTTORE SEDILE | SEAT MICRO SWITCH | MICRO INTERRUPTEUR SIEGE | SITZMIKROSCHALTER |
| 16 MICROINTERRUTTORE FRENO | BRAKE MICRO SWITCH | MICRO INTERRUPTEUR FREIN | BREMSE MIKROSCHALTER |
| 18 INTERRUTTORE FRIZIONE | CLUTCH SWITCH | MICRO INTERR. EMBRAJAGE | KUPPLUNG SCHALTER |

- | | | | |
|---------------------|----------------------|-----------------------|---------------------|
| COLORI CAVI | CABLE COLOURS | COULEUR CABLES | KABEL FARBEN |
| AR ARANCIONE | ORANGE | ORANGE | ORANGE |
| BI BIANCO | WHITE | BLANC | WEISS |
| BL BLU | BLUE | BLEU | BLAU |
| GI GIALLO | YELLOW/GREEN | JAUNE/VERT | GELB/GRÜN |
| GR GRIGIO | GREY | GRIS | GRAU |
| MA MARRONE | BROWN | BRUN | BRAUN |
| NE NERO | BLACK | NOIR | SCHWARZ |
| RO ROSSO | RED | ROUGE | ROT |
| VI VIOLA | VIOLET | VIOLET | VIOLETT |