

REPAIR PARTS

TRACTOR -- MODEL NUMBER UM1136D

ELECTRICAL

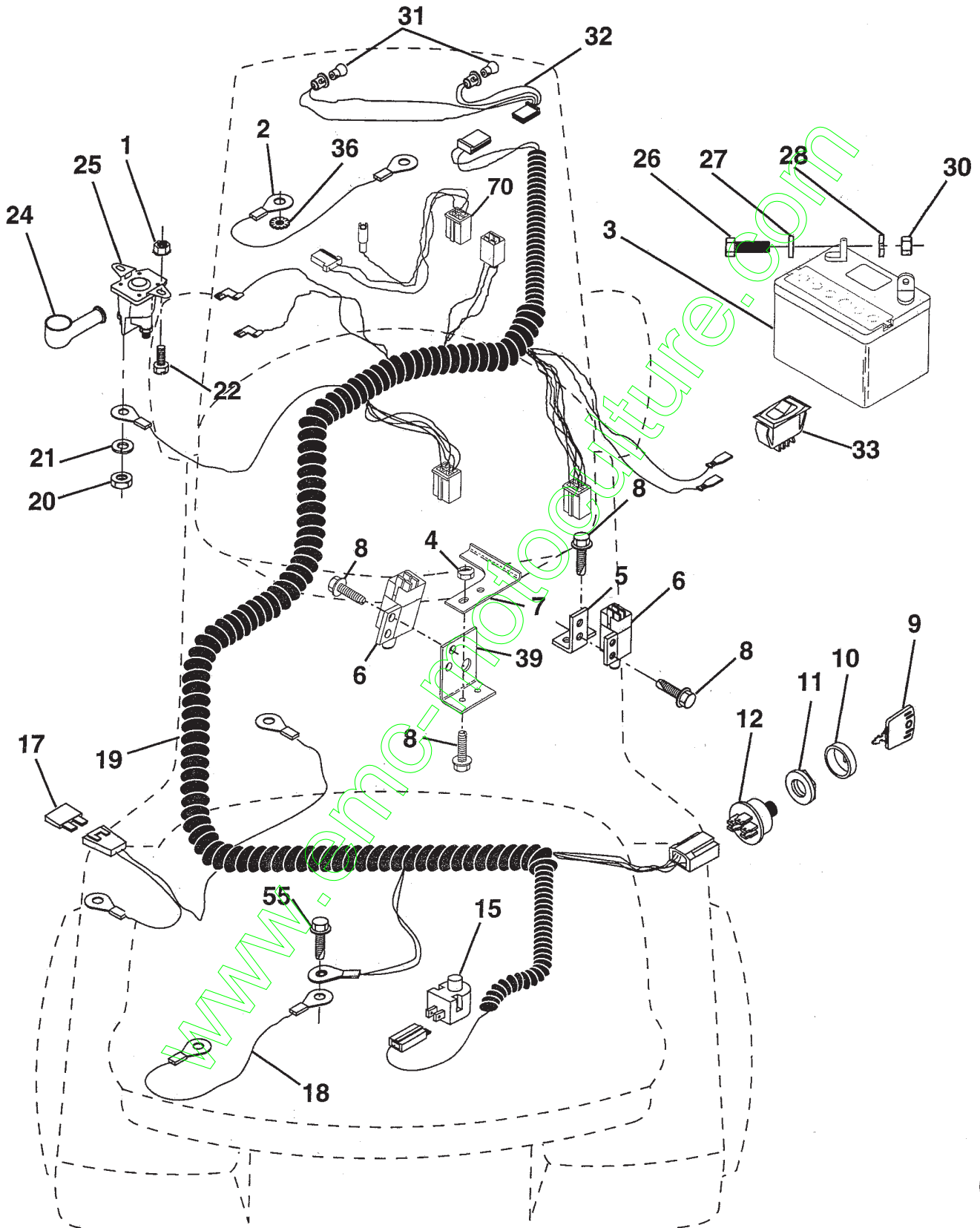

REPAIR PARTS

TRACTOR - - MODEL NUMBER UM1136D

ELECTRICAL

KEY NO.	PART NO.	DESCRIPTION
1	73640400	Nut, Hex, Keps. 1/4-20 UNC
2	108423X	Assembly, Cable
3	144924	Battery
4	69180	Nut, Lock #10-24 UNC
5	108236X	Bracket, Switch
6	109553X	Switch, Interlock 4 Terminal
7	146374	Keeper, Acuator
8	17021008	Screw, Hex Head, Tapping #10-24 x 1/2
9	140401	Key
10	141226	Cover, Ignition Key
11	140400	Nut, Ignition
12	144921	Switch, Ignition
15	121305X	Switch, Plunger
17	108824X	Fuse
18	128353	Assembly, Cable
19	146064	Harness, Ignition
20	73350400	Nut, Hex, Jam 1/4-20
21	10090400	Washer, Lock 1/4
22	71110408	Bolt, Hex, Fin. 1/4-20 UNC x 1/2 Grade 5
24	131563	Cover, Terminal
25	145673	Solenoid
26	74760412	Bolt, Hex Head 1/4-20 UNC x 3/4
27	19091016	Washer 9/32 x 5/8 x 16
28	10040400	Washer, Lock, Hvy. Hel. Spring 1/4
30	73220400	Nut, Hex, Fin. 1/4-20
31	4152J	Bulb, Light #1156
32	136850	Harness, Asm. Light w/4152J
33	110712X	Switch, Light Blk.Blk.Red
36	11150400	Washer Lock Internal Tooth 1/4
39	141735	Bracket, Switch Clutch
55	17490508	Screw, Thdrol. 5/16-18 x 1/2
70	140413	Harness, Engine

NOTE: All component dimensions given in U.S. inches.
♦ 1 inch = 25.4 mm

HARDWARE SHOWN LARGER FOR EASIER IDENTIFICATION

REPAIR PARTS

TRACTOR - - MODEL NUMBER UM1136D

FENDER / CHASSIS

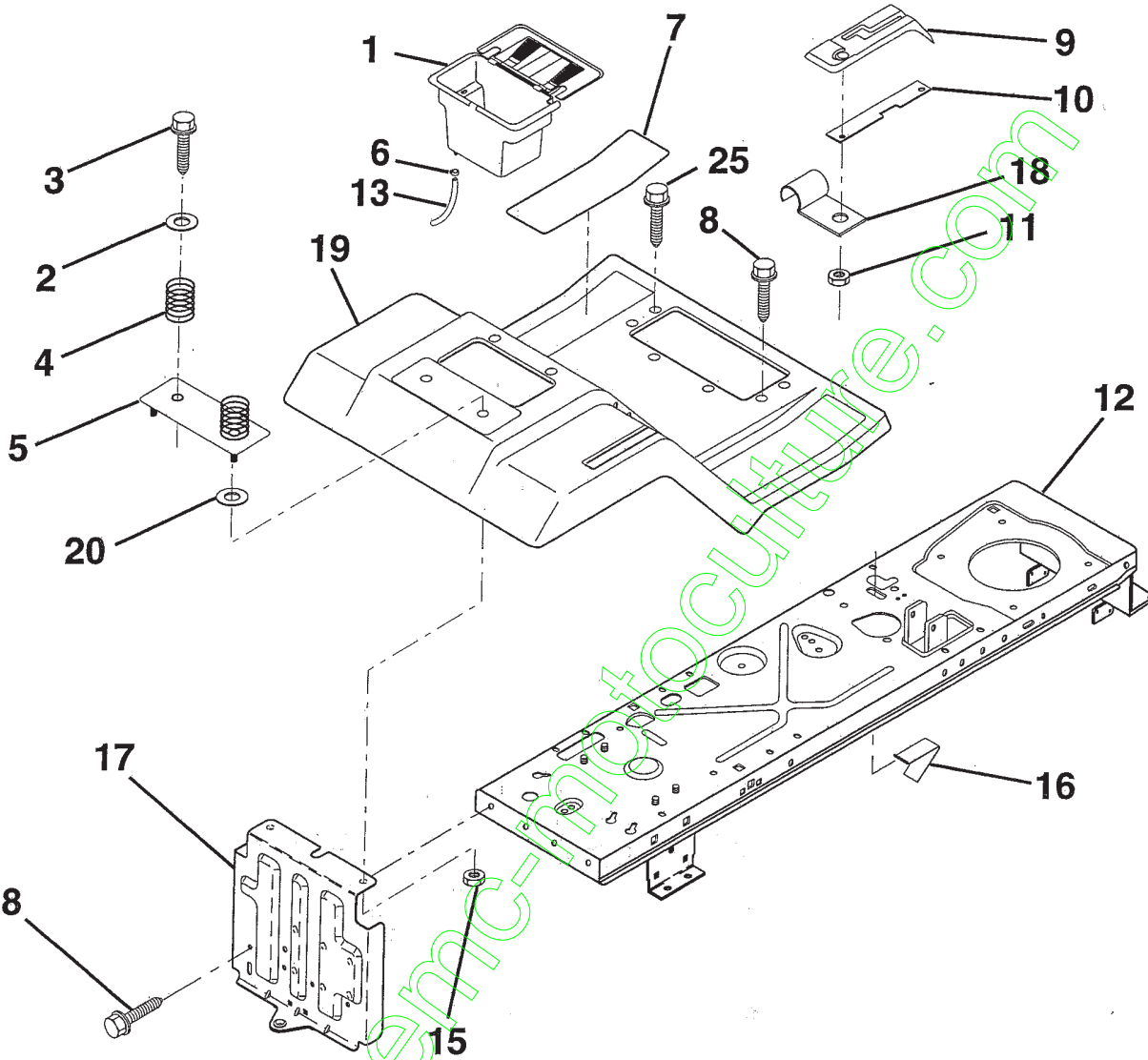

KEY NO.	PART NO.	DESCRIPTION
1	144940	Case Battery Hng Mech w/Lid
2	19132012	Washer 13/32 x 1 1/4 x 12 Ga
3	17490612	Screw Thdrol 3/8-16 x 3/4
4	124181X	Spring Seat
5	127115X505	Plate Asm Battery
6	109596X	Clamp Hose
7	124144X	Pad Footrest
8	17490512	Screw Thdrol 5/16-18 x 3/4
9	126994X	Console Shift
10	139783	Plate Lock Shift
11	124346X	Nut Self-Thd Wsh-Hd 1/4

KEY NO.	PART NO.	DESCRIPTION
12	145190	Chassis Asm
13	109238X	Tube Plastic
15	73640400	Nut Hex 1/4-20
16	141736	Swtich Activator
17	140782	Drawbar
18	126470X	Clip Insulated
19	140955X505	Fender/Footrest
20	19091413	Washer 9/32 x 7/8 x 13 Ga
25	17190516	Screw Thdrol 5/16-18 x 1

NOTE: All component dimensions given in U.S. inches.
1 inch = 25.4 mm

HARDWARE SHOWN LARGER FOR EASIER IDENTIFICATION

REPAIR PARTS

TRACTOR - - MODEL NUMBER UM1136D

HOOD

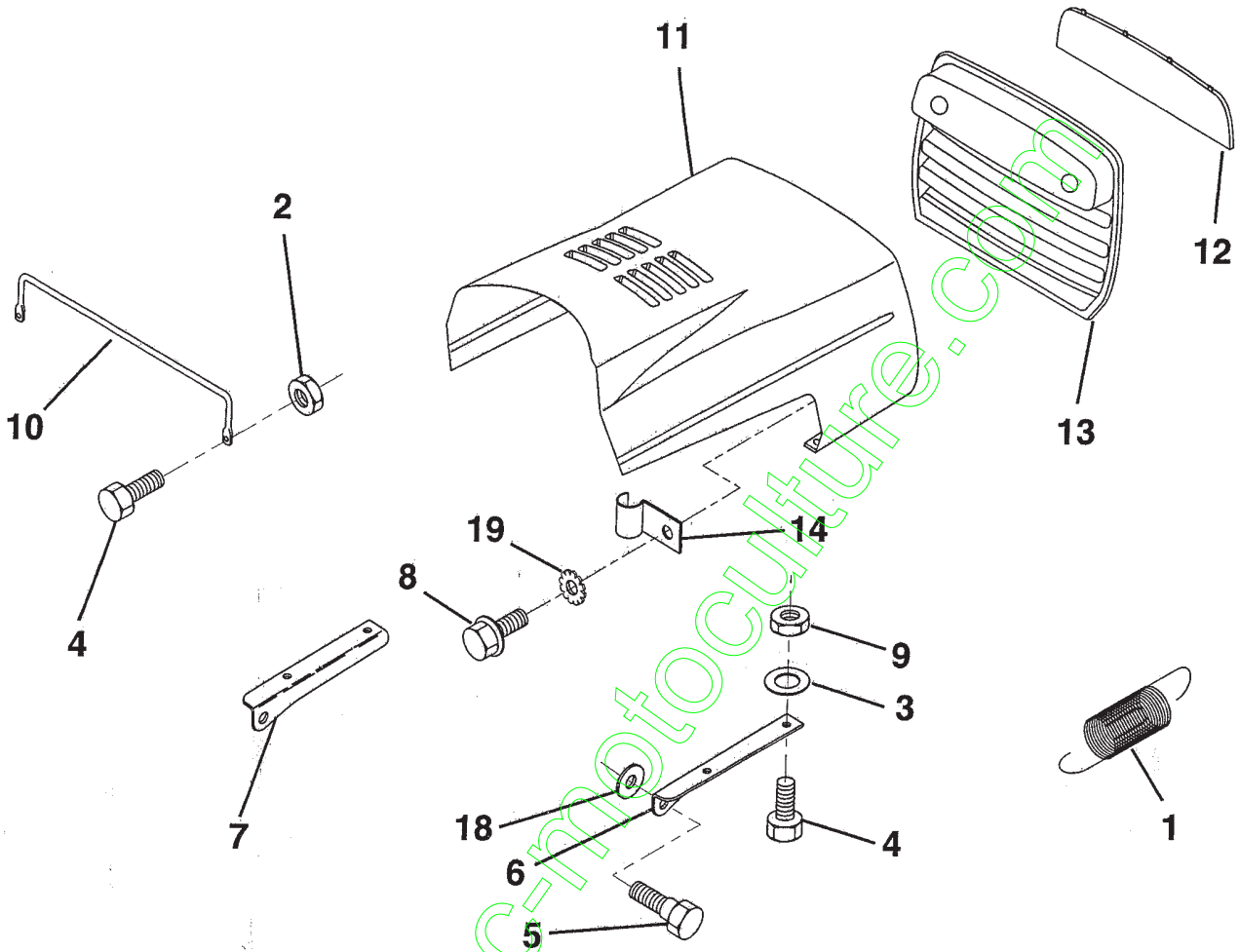

KEY NO.	PART NO.	DESCRIPTION
1	124657X	Spring
2	73640400	Nut 1/4-20
3	19091416	Washer 9/32 x 7/8 x 16 Ga.
4	74780412	Bolt Fin Hex 1/4-20 x .75
5	139888	Bolt Shoulder 5/16-18
6	122549X	Bracket Hood RH
7	122548X	Bracket Hood LH
8	17521312	Screw Slt'd Hex Hd w/Pl Washer
9	73800400	Nut Lock w/insert 1/4 - 20
10	123693X	Brace Hood

KEY NO.	PART NO.	DESCRIPTION
11	132918X550	Hood
12	122035X	Lens Clear Bar
13	127029X	Grille
14	2751R	Clip Line Fuel 13/32
18	19111116	Washer 11/32 x 11/16 x 16 Ga
19	11030400	Washer Lock 1/4 Int/Ext Tooth

NOTE: All component dimensions given in U.S. inches
1 inch = 25.4 mm

HARDWARE SHOWN LARGER FOR EASIER IDENTIFICATION

REPAIR PARTS

TRACTOR - - MODEL NUMBER UM1136D

SEAT

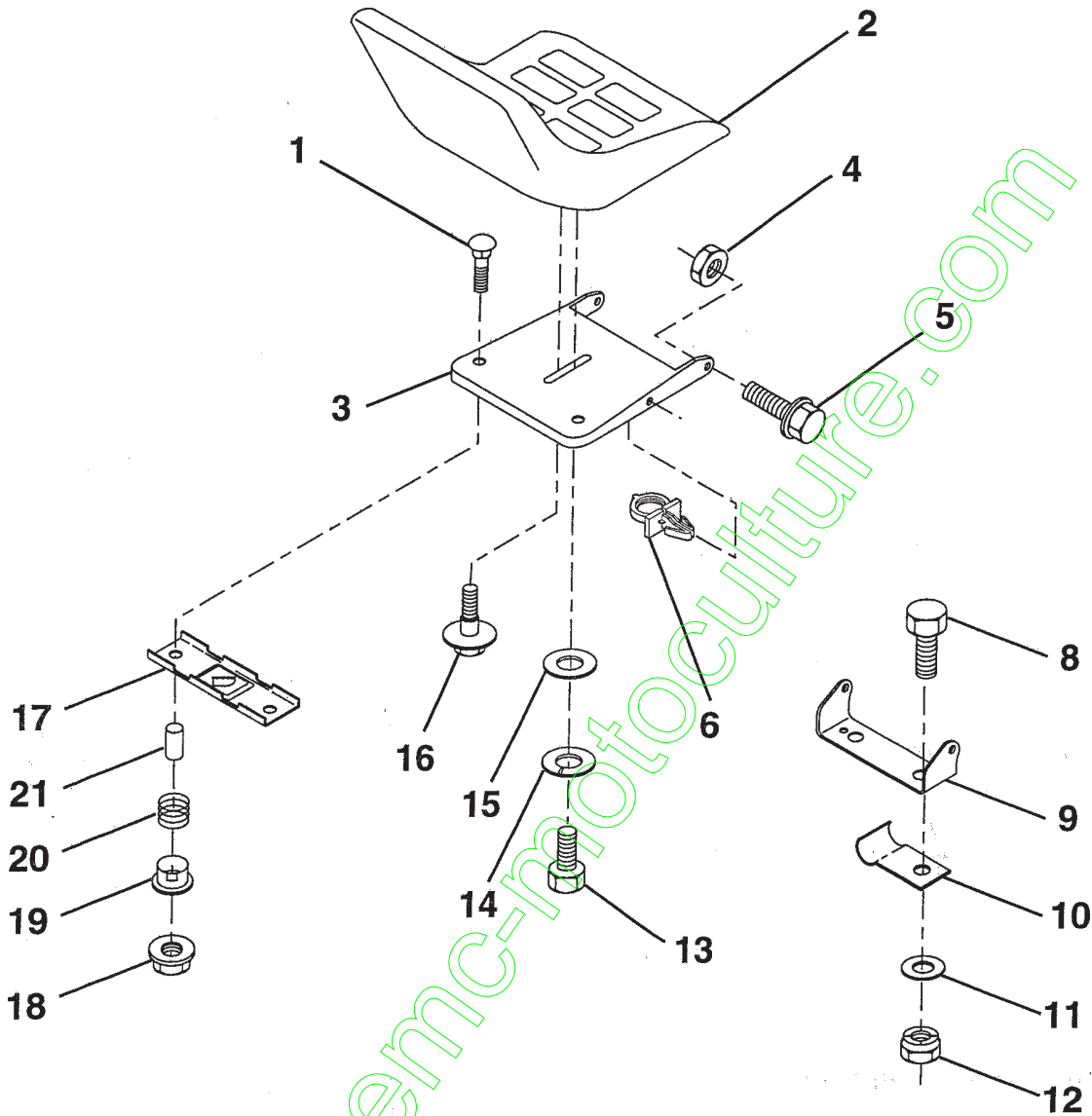

KEY NO.	PART NO.	DESCRIPTION
1	72050411	Bolt, Carriage 1/4-20 x 1-3/8
2	127428	Seat
3	140552	Pan, Seat
4	73800500	Nut, Hex W/Ins. 5/16-18 UNC
5	139888	Bolt Shld. 5/16-18
6	145006	Clip, Push-In
8	74760616	Bolt, Hex, Fin. 3/8-16 UNC x 3/4
9	140551	Bracket, Pivot, Seat
10	126471X	Clip Insulated
11	19133210	Washer 12/32 x 2 x 10 Gauge
12	73800600	Nut, Lock Hex w/Wsh 3/8-16

KEY NO.	PART NO.	DESCRIPTION
13	74780814	Bolt, Hex, Fin. 1/2-13 UNC x 7/8 Grade 5
14	10040800	Washer, Lock, Heavy Helical Spring
15	19171912	Washer 17/32 x 1-3/16 x 12 Ga.
16	127018X	Bolt, Shoulder
17	121246X	Bracket, Switch Mounting
18	123976X	Nut, Hex, Large, Flangelock
19	121248X	Bushing, Snap
20	121250X	Spring, Cprsn. Plate Sw.
21	134300	Spacer, Split

NOTE: All component dimensions given in U.S. inches.
1 inch = 25.4 mm

HARDWARE SHOWN LARGER FOR EASIER IDENTIFICATION

REPAIR PARTS

TRACTOR -- MODEL NUMBER UM1136D

DASH

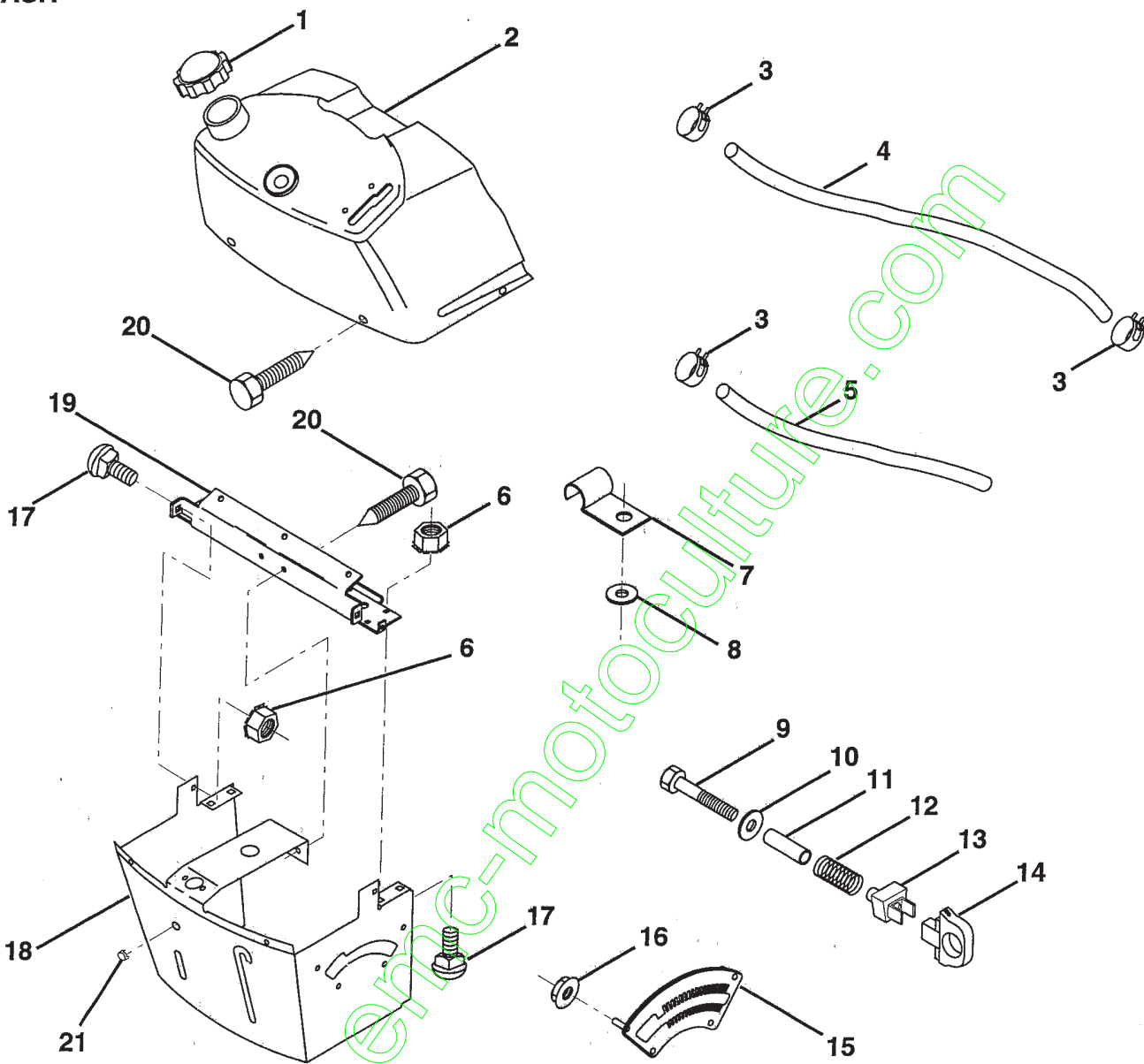

KEY NO.	PART NO.	DESCRIPTION
1	141523	Cap, Fuel
2	138392	Assembly, Dash & Fuel Tank
3	123487X	Clamp, Hose
4	8544R	Line, Fuel
5	8548R	Line, Fuel
6	73640400	Nut, Hex, Keps 1/4-20
7	2751R	Clip, Fuel Line
8	19091216	Washer 9/32 x 3/4 x 16 Ga.
9	74760428	Bolt, Hex, Fin. 1/4-20 x 1-3/4
10	19091413	Washer 11/32 x 11/16 x 16 Ga.
11	121249X	Spacer, Split
12	3720R	Spring

KEY NO.	PART NO.	DESCRIPTION
13	126450X	Clip, Height Adjustment
14	126115X	Knob, Height Stop
15	122023X	Adjustment, Quadrant Height
16	124346X	Nut, Self-Threading 3/16-18
17	72110404	Bolt, Carriage 1/4-20 x 1/2 Gr. 5
18	130745	Support Assembly, Dash
19	134744	Brace, Cross
20	17060408	Screw, Self-Tapping 1/4-20 x 1/2
21	134014	Plug, Dome

NOTE: All component dimensions given in U.S. inches.
1 inch = 25.4 mm

HARDWARE SHOWN LARGER FOR EASIER IDENTIFICATION

REPAIR PARTS

TRACTOR - - MODEL NUMBER UM1136D

STEERING WHEEL

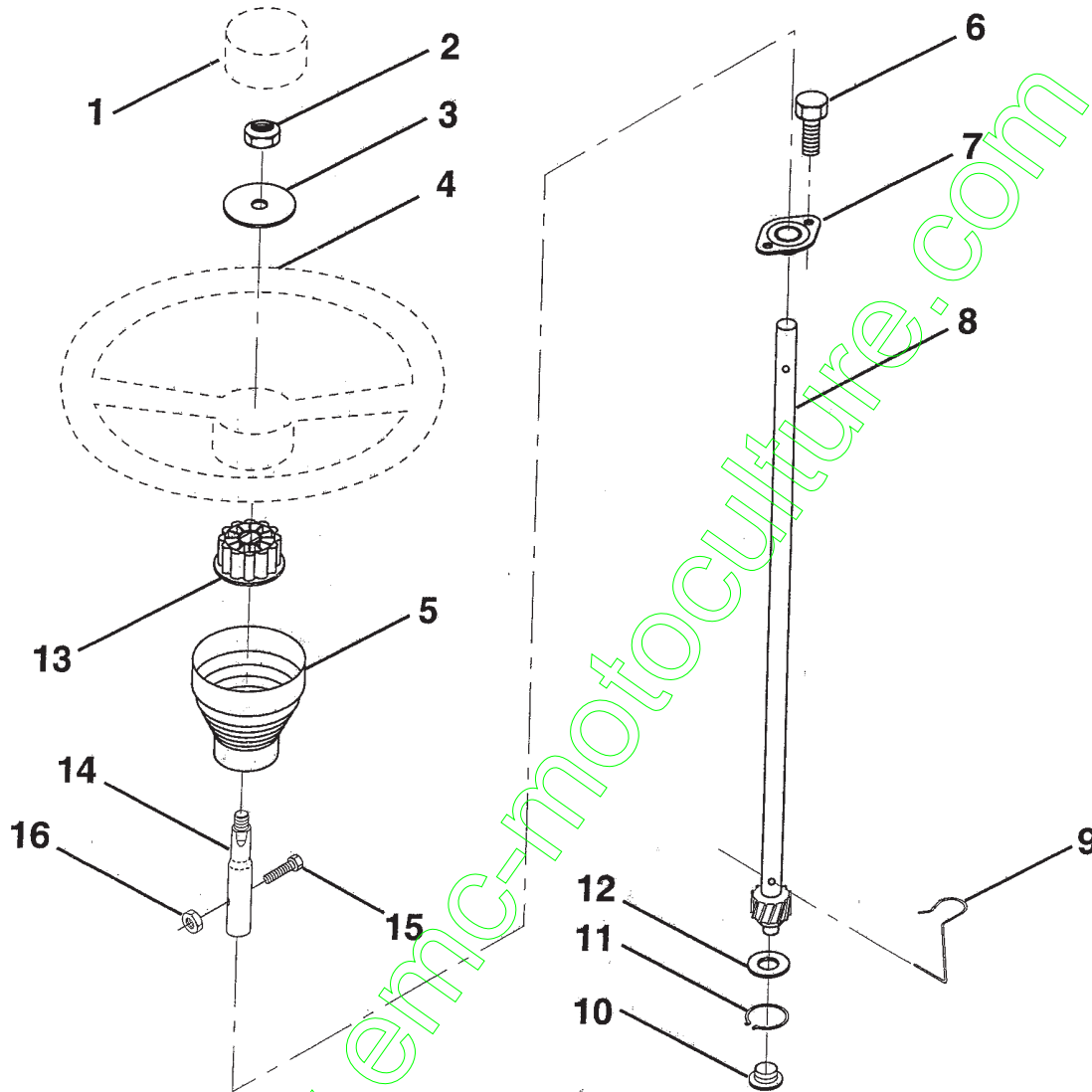

KEY NO.	PART NO.	DESCRIPTION
1	133742	Insert, Steering Wheel
2	7810H	Locknut 3/8-24 UNF
3	19133808	Washer 12/32 x 2-3/8 x 8 Gauge
4	133741	Steering Wheel
5	121897X	Sleeve, Steering
6	17431008	Screw, Hex #10-16 x 1/2 TY-B
7	102803X	Bushing, Steering
8	147391	Shaft, Steering
9	124210X	Clip, Steering

KEY NO.	PART NO.	DESCRIPTION
10	123438X	Bushing, Lower, Steering
11	12000045	Ring, Retaining
12	19211616	Washer 21/32 x 1 x 16 Gauge
13	104820X	Adaptor, Steering Wheel
14	147392	Extension, Shaft Steering
15	74780520	Bolt, Fin, Hex 5/16-18 UNC x 1-1/4
16	73800500	Nut, Lock Hex W/Ins. 5/16-18 UNC

NOTE: All component dimensions given in U.S. inches.
1 inch = 25.4 mm

HARDWARE SHOWN LARGER FOR EASIER IDENTIFICATION

REPAIR PARTS

TRACTOR -- MODEL NUMBER UM1136D

SECTOR GEAR / AXLE SUPPORT

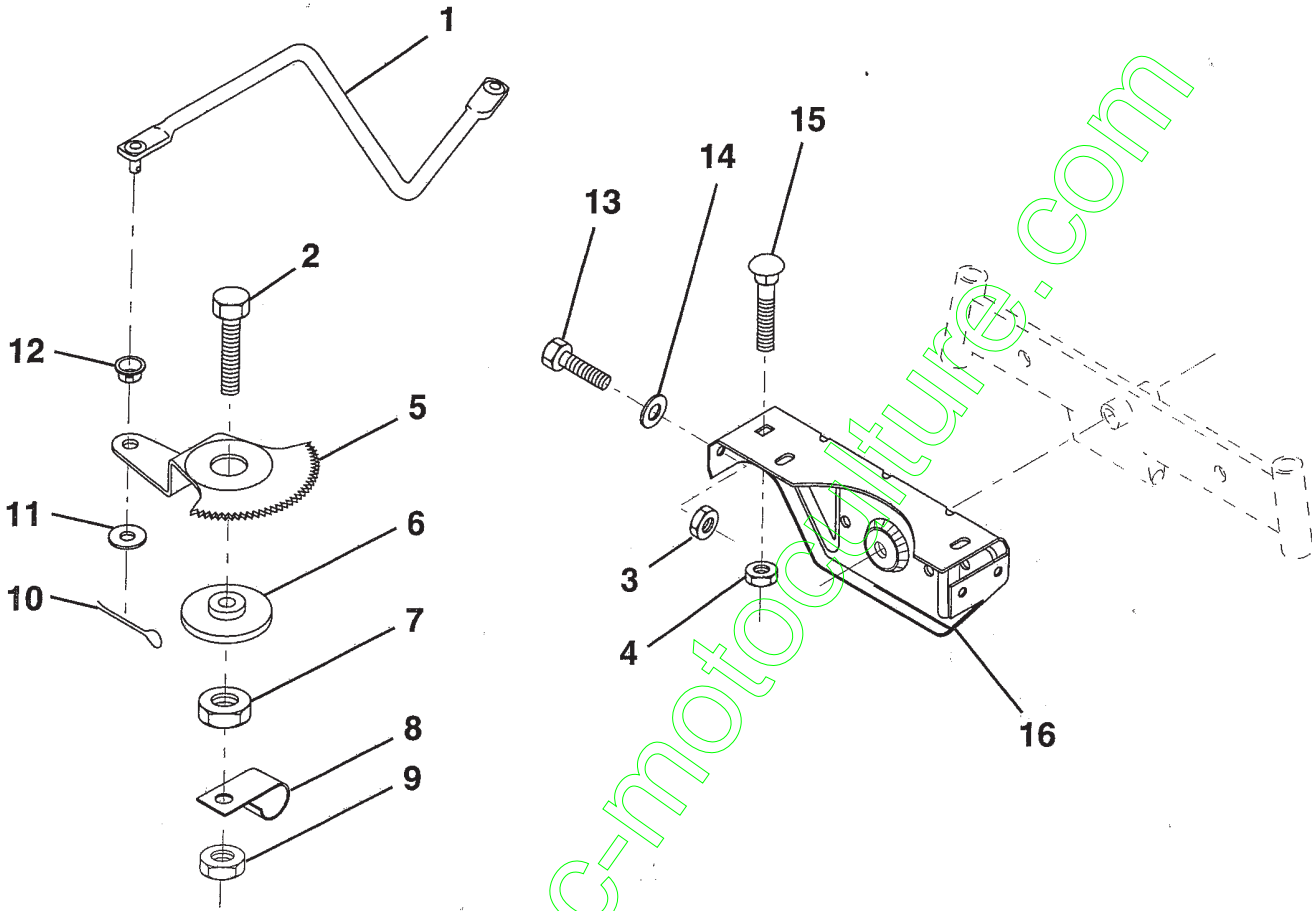

KEY NO.	PART NO.	DESCRIPTION
1	132566	Link, Drag
2	74780828	Bolt, Hex, Fin. 1/2-13 x 1-3/4
3	73680500	Nut, Crownlock 5/16-18
4	73680600	Nut, Crownlock 3/8-16
5	121926X	Gear, Sector
6	121927X	Bushing
7	73030800	Nut, Heavy Hex, Top Lock 1/2-13 UNC
8	126472X	Clip, Insulated
9	73680800	Nut, Crownlock 3/8-16

KEY NO.	PART NO.	DESCRIPTION
10	76020412	Pin, Cotter 1/8 x 3/4
11	19131316	Washer 13/32 x 13/16 x 16 Ga.
12	126847X	Bushing
13	74760512	Bolt, Hex Hd 5/16 - 18 x 3/4
14	19111416	Washer 11/32 x 7/8 x 16 Ga.
15	72110606	Bolt, Carriage 3/8-16 UNC x 3/4
16	137096	Support, Front Axle

NOTE: All component dimensions given in U.S. inches.
1 inch = 25.4 mm

HARDWARE SHOWN LARGER FOR EASIER IDENTIFICATION

REPAIR PARTS

TRACTOR -- MODEL NUMBER UM1136D

FRONT AXLE

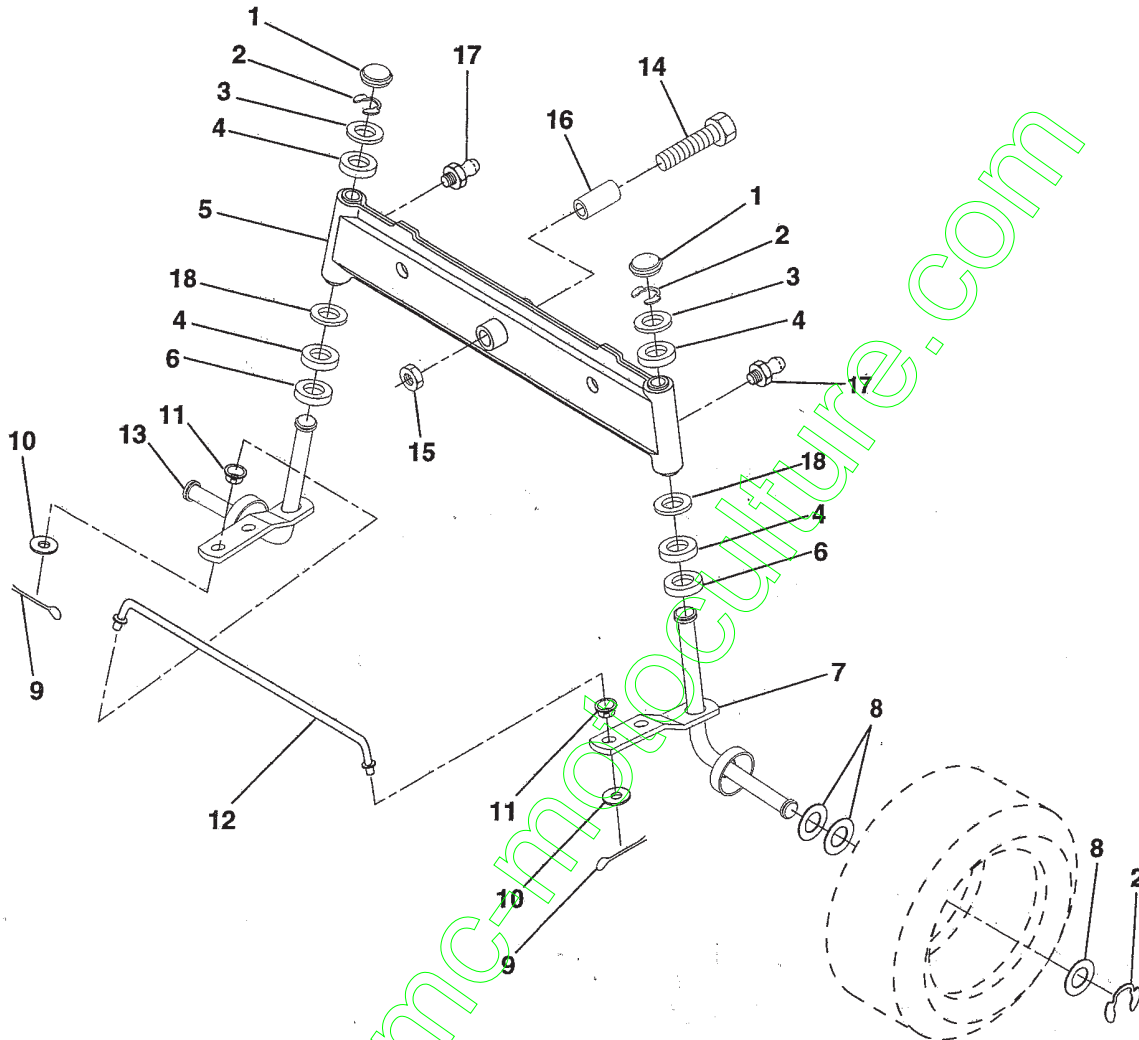

KEY NO.	PART NO.	DESCRIPTION
1	121232X	Cap, Spindle
2	1200029	Ring, Clip
3	121748X	Washer 25/32 x 1-5/8 x 16 Ga.
4	3366R	Bearing
5	142033	Axle, Front
6	6266H	Bearing, Thrust
7	137062	Spindle Assembly, R.H.
8	121749X	Washer 25/32 x 1-1/4 x 16 Ga.
9	76020412	Pin, Cotter 1/8 x 3/4
10	19131316	Washer 13/32 x 13/16 x 16 Ga.

KEY NO.	PART NO.	DESCRIPTION
11	126847X	Bushing
12	130465	Rod, Tie
13	137061	Spindle Assembly, L.H.
14	74011056	Bolt Hex 5/8-11 X 3-1/2
15	73901000	Nut, Lock Flange 5/8-11
16	110438X	Spacer, Bearing
17	6855M	Fitting, Grease
18	19272016	Washer 27/32 X 1-1/4 X 16 Ga.

NOTE: All component dimensions given in U.S. inches.
1 inch = 25.4 mm

HARDWARE SHOWN LARGER FOR EASIER IDENTIFICATION

REPAIR PARTS

TRACTOR -- MODEL NUMBER UM1136D

ENGINE / THROTTLE

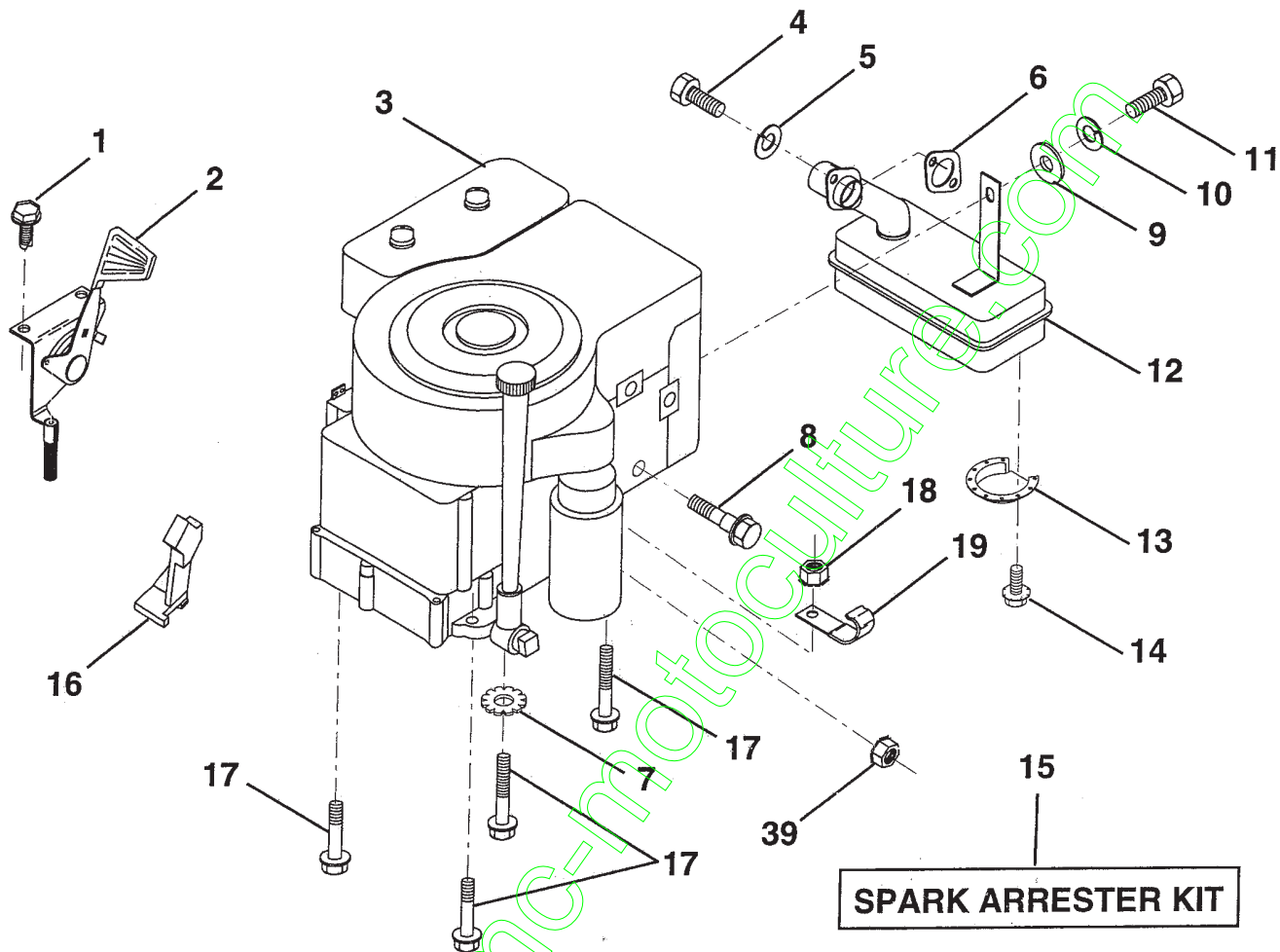

KEY NO.	PART NO.	DESCRIPTION
1	17060408	Screw 1/4-20 x 1/2
2	133025	Control, Throttle
3	----	Engine, B&S Model No. 282707
4	71070512	Screw, Hex Cap Head 5/16-18 x 3/4
5	10040500	Washer, Lock 5/16
6	272293	Gasket, Exhaust
7	11050600	Washer, Lock Ext. Tooth 3/8
8	121094X	Bolt, Shoulder 5/16
9	19101216	Washer 5/16 x 3/4 x 16 Ga.
10	10040400	Washer, Lock, Heavy Helical Spring 1/4

KEY NO.	PART NO.	DESCRIPTION
11	----	Bolt (Order from Engine Mfg.)
12	137437	Muffler
13	101326L	Deflector Muffler
14	17030808	Screw spiderloc Hex Hd. 8 X 1/2
15	137180	Arrester, Spark (Optional)
16	127951	Stop, Throttle
17	17490624	Screw, Hex Washer Head, Thd., Roll. 3/8-16 x 1-1/2
18	73510600	Nut, Keps Hex 3/8-16 Unc
19	2751R	Clip, Line Fuel 13/32 Mfg. Hole
39	128861	Nut Flange 1/4-20

NOTE: All component dimensions given in U.S. inches.
1 inch = 25.4 mm

HARDWARE SHOWN LARGER FOR EASIER IDENTIFICATION

REPAIR PARTS

TRACTOR -- MODEL NUMBER UM1136D

GROUND DRIVE

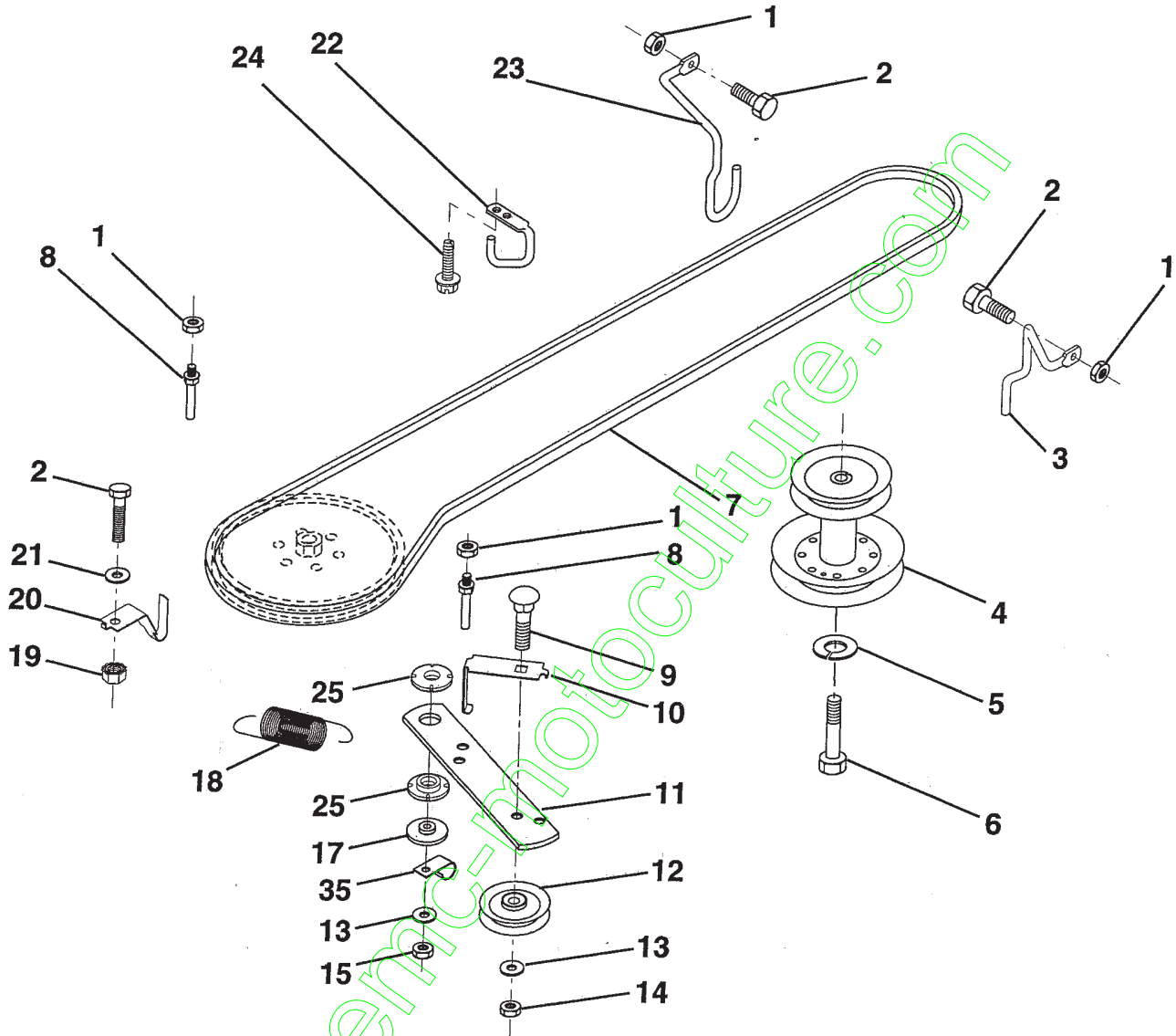

KEY NO.	PART NO.	DESCRIPTION
1	73680500	Nut, Crownlock 5/16-18
2	74760512	Bolt, Hex Hd. 5/16-18 UNC x 3/4
3	141342	Keeper, Mower Drive Belt, R.H.
4	138029	Pulley, Engine
5	10040700	Washer, Lock 7/16
6	71170744	Bolt, Hex, Fin. 7/16-20
7	124525X	Traction, V-Belt, Drive
8	123405X	Keeper, T/A, Ground Drive Belt
9	72140612	Bolt, Carriage 3/8-16 UNC x 1-1/2
10	123396X	Keeper, Ground Drive, Belt, Idler
11	150926	Clutch Arm, Ground Drive
12	123674X	Idler, Flat
13	19131316	Washer 13/32 x 13/16 x 16 Ga.
14	73930600	Nut, Centerlock 3/8-16 UNC

KEY NO.	PART NO.	DESCRIPTION
15	73680600	Nut, Crownlock 3/8-16
16	126471X	Clip Insulator
17	150932	Spacer, Retainer
18	131459	Spring Extension
19	73510500	Nut, Hex, Keps 5/16-18 UNC
20	139919	Keeper, T/A, Ground Drive Belt
21	19111016	Washer 11/32 x 5/8 x 16 Gauge
22	123404X	Keeper, Frame, Ground Drive Belt
23	140916	Keeper, Mower Drive Belt, L.H.
24	17720408	Screw Thd Cut 1/4-20X1/2
25	150935	Bushing, Nylon

NOTE: All component dimensions given in U.S. inches.
1 inch = 25.4 mm

HARDWARE SHOWN LARGER FOR EASIER IDENTIFICATION

REPAIR PARTS

TRACTOR -- MODEL NUMBER UM1136D

TRANSAXLE

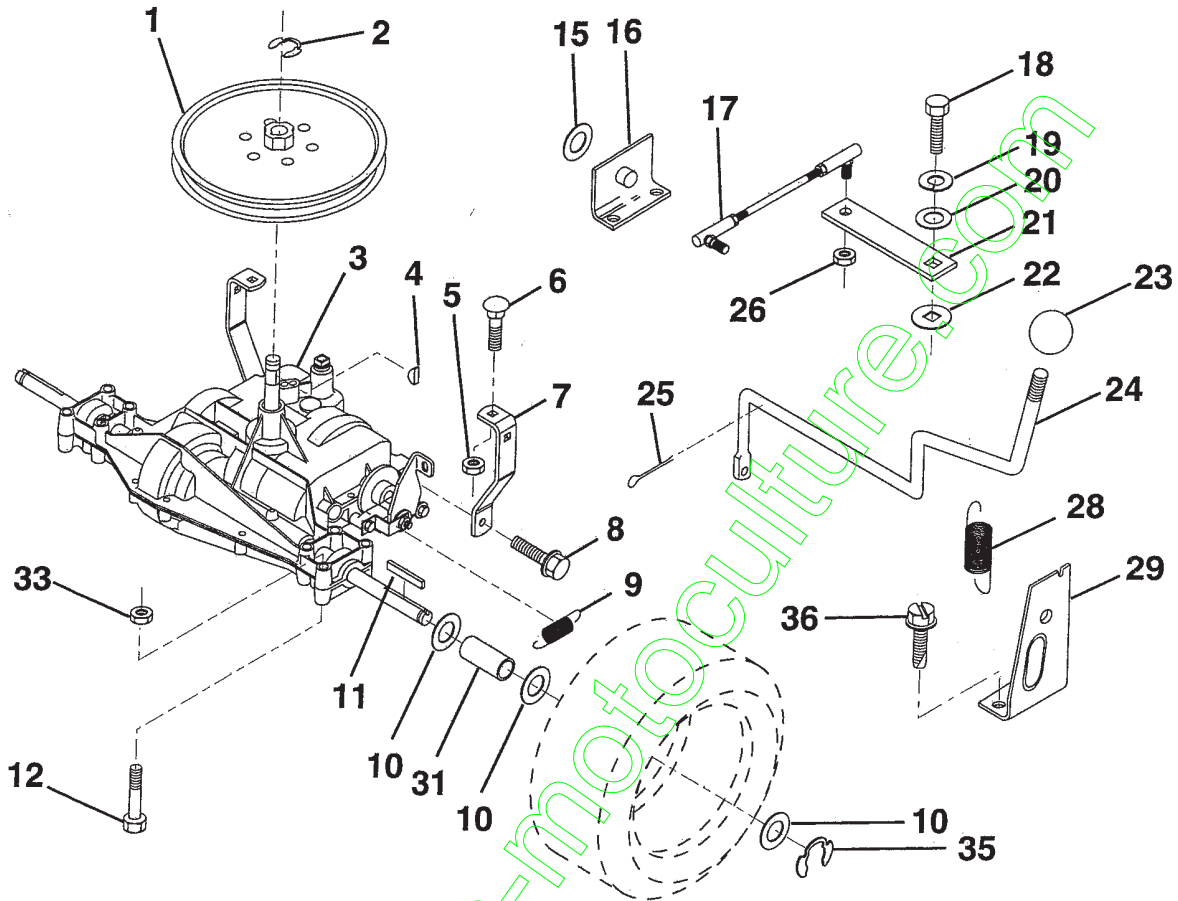

KEY NO.	PART NO.	DESCRIPTION
1	123385X	Pulley
2	12000028	Ring, Retainer
3	142602	Transaxle Dana, 5 Speed, Model Number 4360-78
4	2228M	Key, Woodruff #9
5	73680500	Nut, Crownlock 5/16-18
6	72140506	Bolt, Carriage 5/16-18 x 3/4
7	123378X	Strap, Torque
8	17490512	Screw, Hex, Thdrl H 5/16-18 x 3/4
9	146682	Spring, Brake
10	121749X	Washer 25/32 x 1-1/4 x 16 Ga.
11	123583X	Key, Square
12	74760644	Bolt Hex 3/8-16 x 2-3/4
15	19171616	Washer 17/32 x 1 x 16 Ga.
16	124600X	Support Handle Shift LH
17	123632X	Link, Shift

KEY NO.	PART NO.	DESCRIPTION
18	74550412	Bolt Hex 1/4-28 x 3/4 Cat. 8
19	10040400	Washer, Lock 1/4
20	19091210	Washer 9/32 x 3/4 x 10 Ga.
21	123484X	Arm, Shift
22	105701X	Washer, Shift Plate
23	106933X	Knob
24	128215	Rod, Shift
25	76020416	Pin, Cotter 1/8 x 1
26	73810500	Nut, Hex, Nylon 5/16-24
28	128085	Spring, Extension
29	128084	Support Handle Shift RH
31	109502X	Spacer
33	73680600	Nut, Crownlock 3/8-16
35	12000001	E Ring
36	17720408	Screw, Thd. Cut. 1/4-20 X 1/2

NOTE: All component dimensions given in U.S. inches.
1 inch = 25.4 mm

HARDWARE SHOWN LARGER FOR EASIER IDENTIFICATION

REPAIR PARTS

TRACTOR -- MODEL NUMBER UM1136D

BRAKE / REAR MOWER LIFT ASSEMBLY

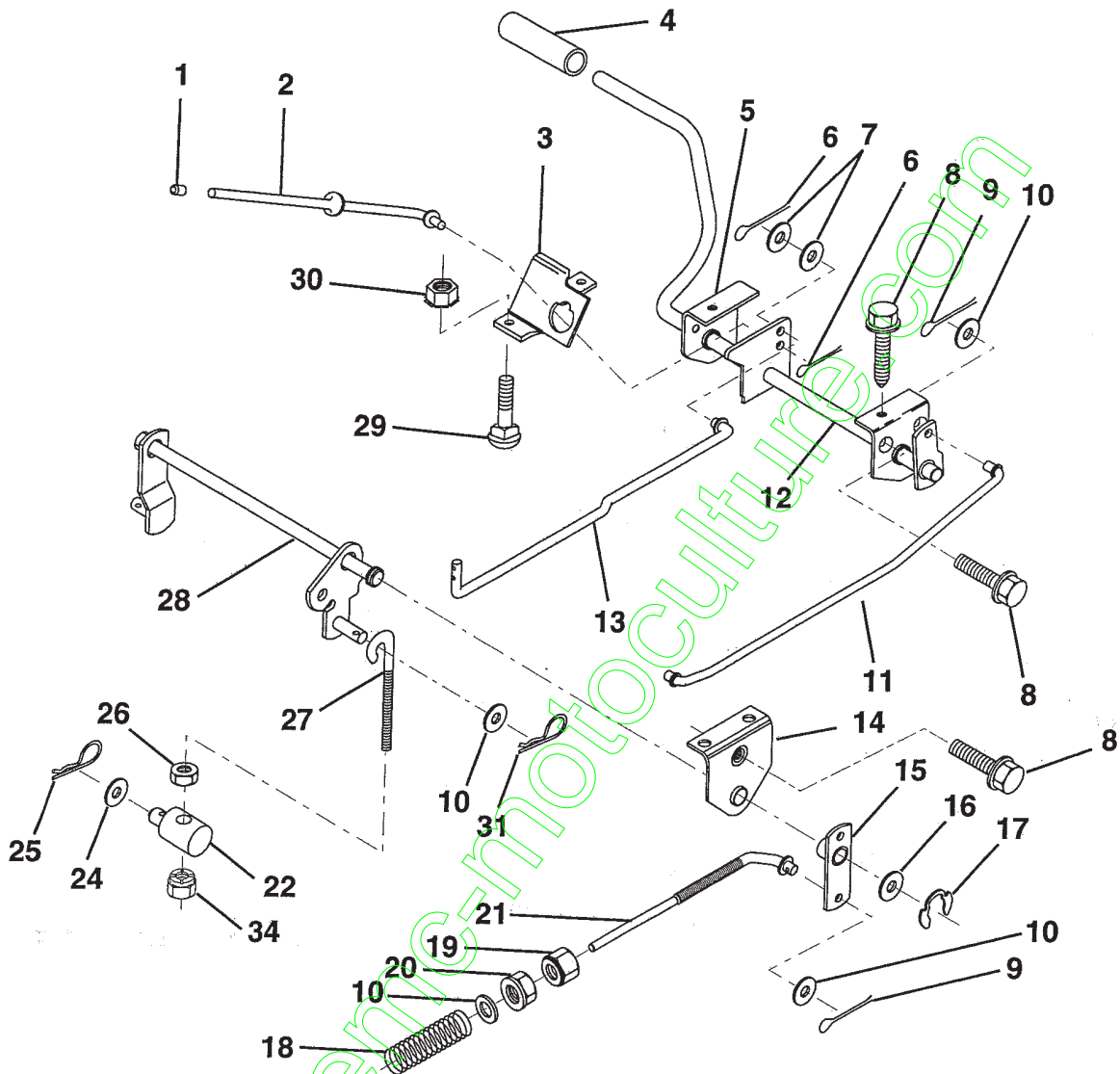

KEY NO.	PART NO.	DESCRIPTION	KEY NO.	PART NO.	DESCRIPTION
1	71673	Cap, Plunger	17	12000034	Ring, Klip
2	123436X	Rod, Parking Brake	18	150932	Spring, Brake Rod
3	123437X	Bracket, Parking Brake	19	73350600	Nut, Hex, Jam 3/8-16 UNC
4	8156H	Cover, Pedal	20	73800600	Nut, Lock Hex W/Ins 3/8-16 UNC
5	122504X	Bracket, Clutch/Brake Pedal, L.H.	21	131460	Rod, Rear, Brake
6	76020312	Pin, Cotter 3/32 x 3/4	22	144585	Trunnion, Lift
7	19131016	Washer 13/32 x 5/8 x 16 Gauge	24	19132012	Washer 13/32 x 1-1/4 x 12 Ga.
8	17490508	Screw, Hex Head, Thd., Roll. 5/16-18 x 1/2	25	4921H	Spring, Retainer
9	76020412	Pin, Cotter 1/8 x 3/4	26	73930600	Nut, Centerlock 3/8-16 UNC
10	19131316	Washer 13/32 x 13/16 x 16 Ga.	27	127369	Link, Threaded
11	123543X	Rod, Brake Front	28	140776	Assembly, Rear Mower Lift
12	139933	Assembly, Clutch/Brake Pedal	29	72110506	Bolt, Carriage 5/16-18 UNC x 3/4
13	123394X	Rod, Clutch	30	73510500	Nut, Hex, Keps 5/16-16 UNC
14	121978X	Bracket, Lift, Shaft	31	3146R	Retainer spring
15	133332	Assembly, Brake, Pivot, Arm	34	73680600	Nut, Crownlock 3/8-16
16	19251816	Washer 25/32 x 1-1/8 x 16 Ga.			

NOTE: All component dimensions given in U.S. inches.
1 inch = 25.4 mm

HARDWARE SHOWN LARGER FOR EASIER IDENTIFICATION

REPAIR PARTS

TRACTOR -- MODEL NUMBER UM1136D

MOWER LIFT LEVER

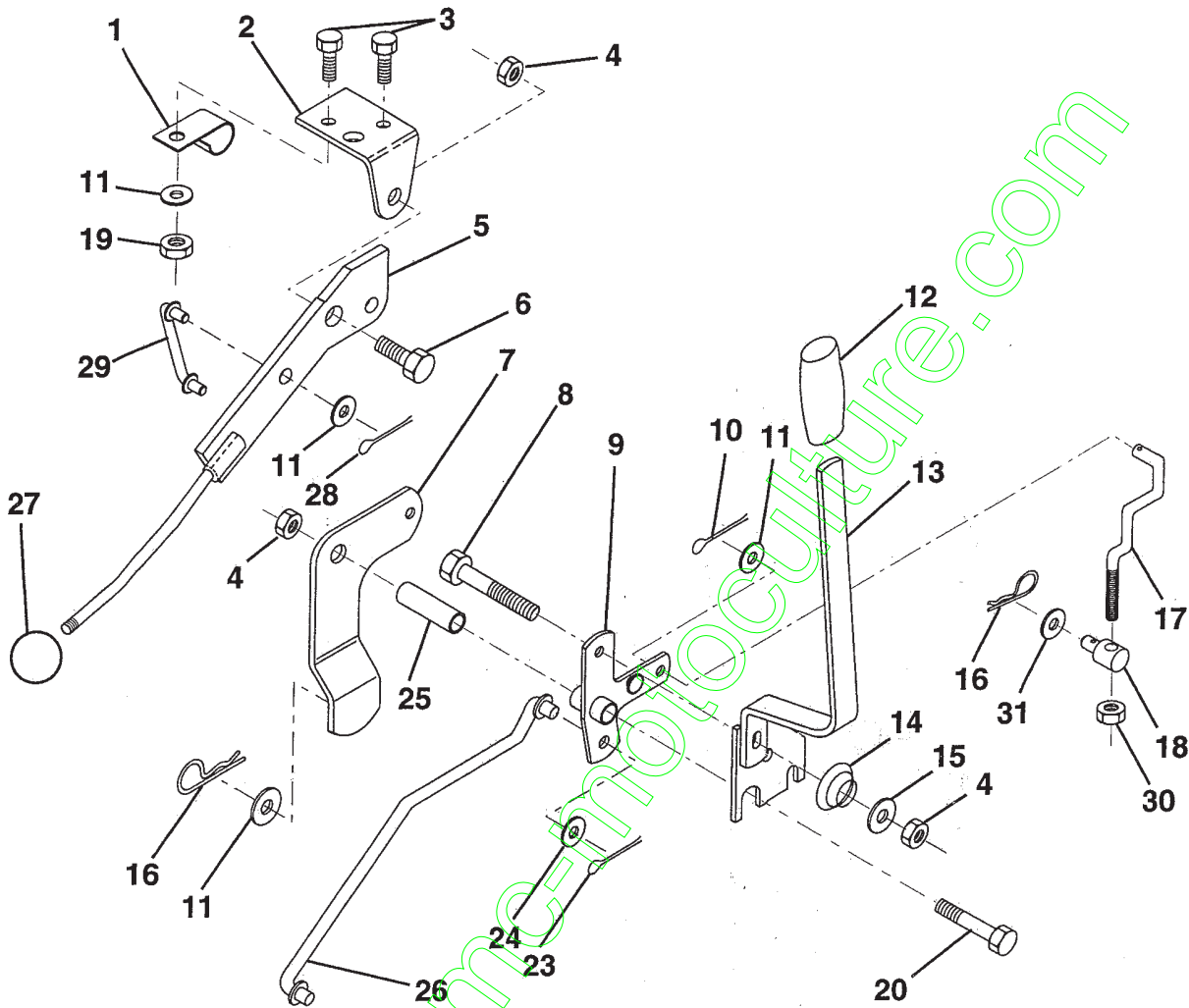

KEY NO.	PART NO.	DESCRIPTION	KEY NO.	PART NO.	DESCRIPTION
1	126470X	Clip, Insulated	16	4921H	Retainer, Spring
2	122018X	Bracket, Mower Clutch	17	127359	Link, Front Lift
3	71110408	Bolt, Hex Head, Fin. 1/4-20 UNC x 1/2 Grade 5	18	142028	Trunnion, Threaded 3/8-16
4	73680600	Nut, Crownlock 3/8-16	19	73680400	Nut, Crownlock 1/4-20
5	145187	Clutch Lever Assembly	20	74760644	Bolt, Hex Head, Fin. 3/8-16 UNC x 2-3/4
6	106451X	Bolt, Shoulder	23	76020416	Pin, Cotter 1/8 x 1
7	135371	Assembly, Mower Clutch Arm	24	19171612	Washer 17/32 x 1 x 12 Ga.
8	74760636	Bolt, Hex 3/8-16 UNC x 2-1/4	25	121933X	Tube, Spacer
9	121930X	Bellcrank Assembly	26	141470	Rod, Mower Lift
10	76020412	Pin, Cotter 1/8 x 3/4	27	106932X	Knob
11	19131316	Washer 13/32 x 13/16 x 16 Ga.	28	76020312	Pin, Cotter 3/32 x 3/4
12	131861	Grip, Handle	29	131655	Link, Mower Clutch
13	139352	Assembly, Lift Handle	30	73350600	Nut, Hex Jam 3/8 - 16
14	123496X	Spring, Compression	31	19132012	Washer 13/32 X 1-1/4 X 12 Ga.
15	19131212	Washer 13/32 x 3/4 x 12 Ga.			

NOTE: All component dimensions given in U.S. inches.
1 inch = 25.4 mm

HARDWARE SHOWN LARGER FOR EASIER IDENTIFICATION

REPAIR PARTS

TRACTOR -- MODEL NUMBER UM1136D

MOWER DECK

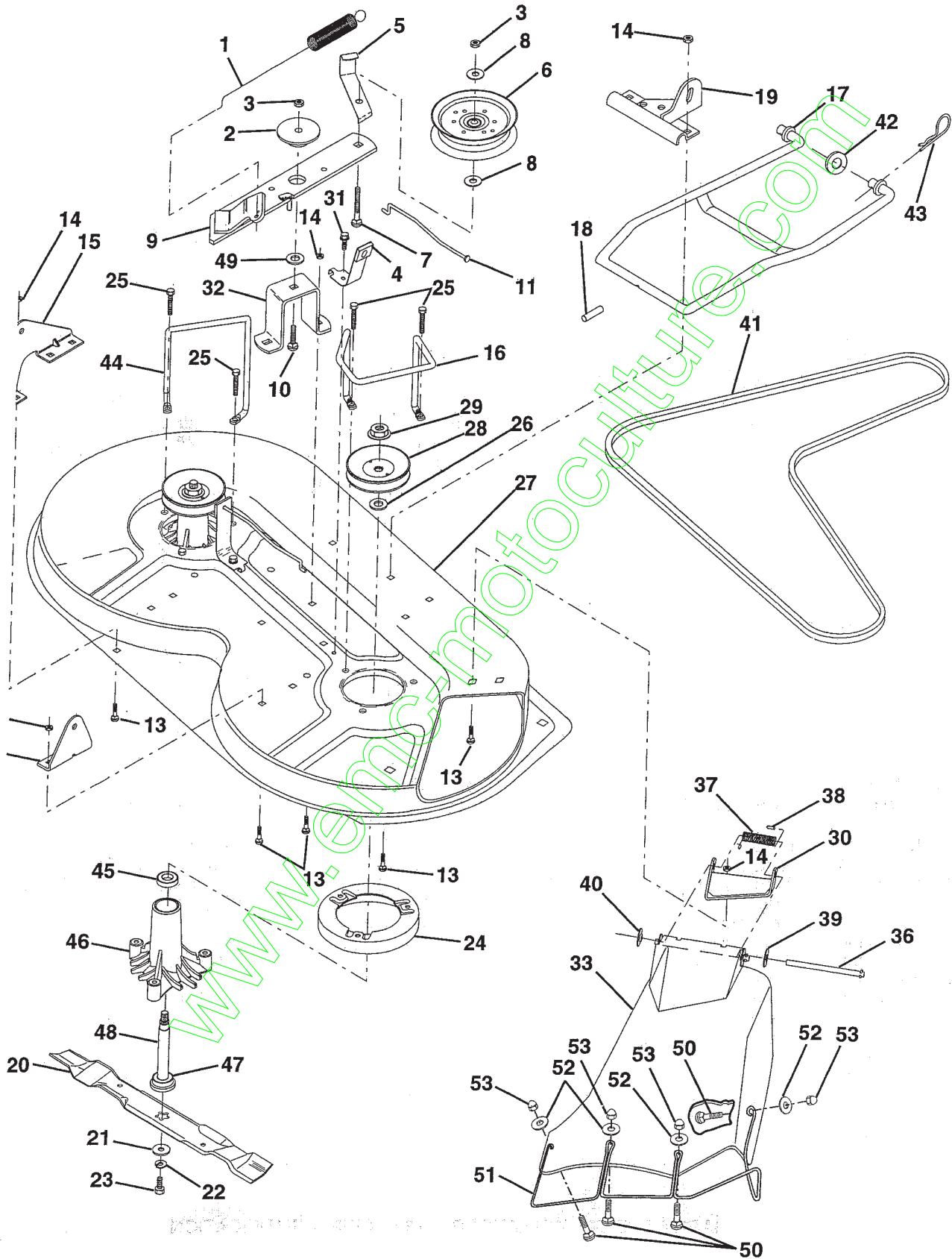

REPAIR PARTS

TRACTOR - - MODEL NUMBER UM1136D

MOWER DECK

KEY PART NO. NO.	DESCRIPTION	KEY PART NO. NO.	DESCRIPTION
1 140064	Spring, Mower Clutch	30 136631	Bracket, Assembly, Deflector
2 122052X	Spacer, Retainer	31 17490508	Screw, Hex Washer Head, Thdrol., 5/16-18 x 1/2
3 73680600	Nut, Crownlock 3/8-16	32 122051X	Arm, Support, Idler, Mower
4 130840	Brake Assembly	33 139083	Deflector
5 131251	Guide, Belt, Idler	36 121980X	Rod, Hinge
6 121316X	Pulley, Flat, Idler	37 123713X	Spring, Torsion, Deflector
7 72110616	Bolt, Carriage 3/8-16 x 2-1/4	38 105304X	Cap, Sleeve
8 19131410	Washer 13/21 x 7/8 x 10 Gauge	39 19111016	Washer 11/32 x 5/8 x 16 Gauge
9 127744	Arm Assembly, Idler, Mower	40 110452X	Push Nut
10 72140610	Bolt, Carriage 3/8-16 x 1-1/4	41 131264	V-Belt
11 130841	Rod, Brake	42 19171616	Washer 11/32 x 5/8 16 Gauge
12 127356	Bracket, Lift, Rear, R.H.	43 3146R	Retainer, Spring
13 72140506	Bolt, Carriage 5/16-18 x 5/8	44 140608	Keeper, L.H.
14 73680500	Nut, Crownlock 5/16-18	45 110485X	Bearing
15 127357	Bracket, Lift, Rear, L.H.	46 128774	Housing, Mandrel, Vented
16 140609	Keeper, R.H.	47 129895	Bearing
17 128508	Link Assembly, Mower Stabilizer	48 137645	Shaft, Mandrel (Includes Key Number 47)
18 128511	Pin, Drive	49 133943	Washer, Hardened
19 127380	Bracket, Assembly, Front	50 71161010	Screw, Truss, Hd. Phil 10-24 x 5/8
20 138496	Blade	51 136383	Guard, Deflector Mower 36" TUV
21 140296	Washer, Hardened	52 19070718	Washer 7/32 x 7/16 X 18 Ga.
22 10030600	Washer, Lock 3/8	53 53260867	Nut, Hex #10-24
23 850857	Bolt 3/8-24 x 1-1/4 Grade 8	-- 130794	Mandrel Assembly (Includes Key No.'s 21-23, 26, 29 and 45-48)
24 140329	Stripper	-- 144973	Mower Deck, Complete
25 138776	Screw Thdrol. Hex Head		
26 129963	Washer .150 Thick		
27 129983	Housing Assembly		
28 129207	Pulley, Mandrel		
29 137266	Nut, Flangelock 9/16		

NOTE: All component dimensions given in U.S. inches.
1 inch = 25.4 mm

HARDWARE SHOWN LARGER FOR EASIER IDENTIFICATION

REPAIR PARTS

TRACTOR - - MODEL NUMBER UM1136D

DECALS

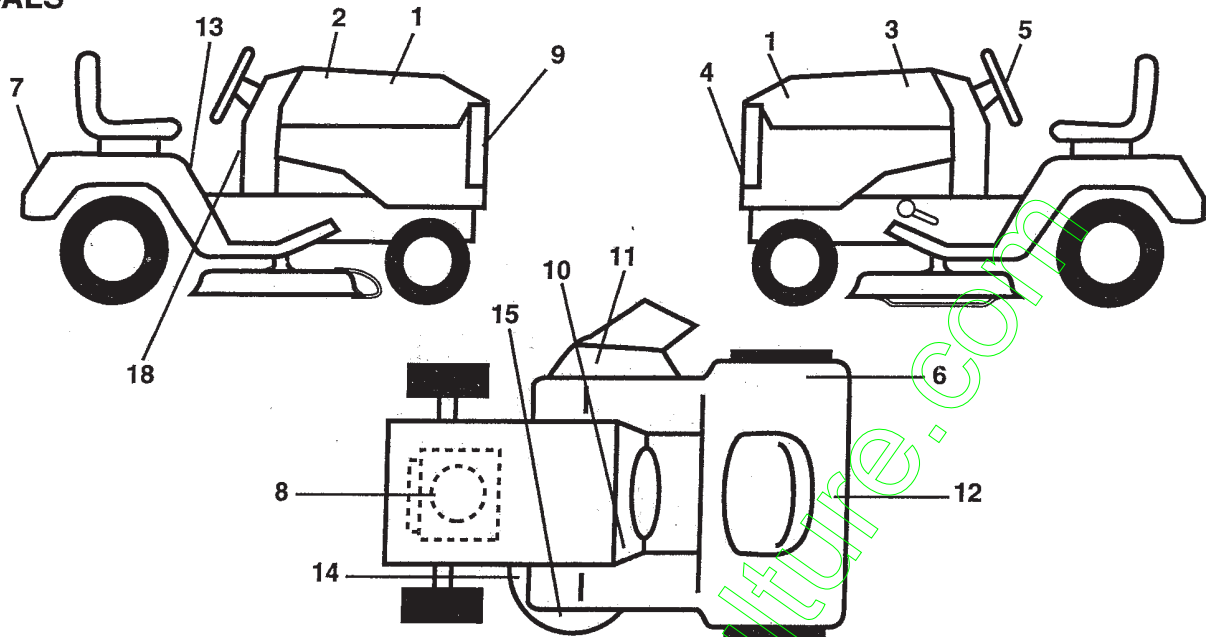

KEY NO.	PART NO.	DESCRIPTION
1	148367	Decal, Hood
2	141743	Decal, Stripe, Hood, R.H.
3	141744	Decal, Stripe, Hood, L.H.
4	132627	Decal, Grill
5	127075X	Decal, Steering Wheel
6	125690X	Decal 100 DBA
7	132628	Decal, Logo, Fender
8	272748	Decal, Engine
9	126860x	Decal, Lightbox
10	145545	Decal, Instruction, Warning (French/English/German/Dutch)

KEY NO.	PART NO.	DESCRIPTION
11	145494	Decal, Warning, Cut Finger Sym
12	145005	Decal, Battery
13	145498	Decal, Caution (English/French)
14	136830	Decal, V-Belt Sch.
15	135013	Decal, Enviro, Deck
18	145437	Decal, Europe, Stand, CE
--	138311	Decal Handle Lift
--	152633	Manual, Operator's (Euro)
--	151286	Manual, Parts

Available accessories not included with tractor:
 -- CE36 Bagger
 -- MK36 Mulcher Kit

WHEELS AND TIRES

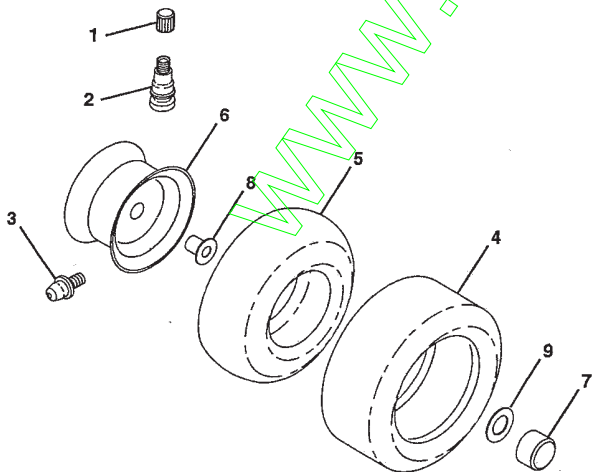

KEY NO.	PART NO.	DESCRIPTION
1	59192	Cap, Valve, Tire
2	65139	Stem, Valve
3	278H	Fitting, Grease
4	137422	Tire, Front
	132703	Tire, Rear
5	59904	Tube, Front Tire (Optional, Service Item Only)
	8134H	Tube, Rear Tire (Optional, Service Item Only)
6	137237X473	Rim Assembly, Front
	140325X473	Rim Assembly, Rear
7	104757X	Cap Axle
8	9040H	Bearing, Flange
9	121748X	Washer 25/32 x 1-5/8 x 16 Gauge
--	144334	Sealant, Tire (10 oz. Tube)

NOTE: All component dimensions given in U.S. inches
 1 inch = 25.4 mm.

REPAIR PARTS

TRACTOR - - MODEL NUMBER UM1136D

DANA TRANSAXLE - MODEL NUMBER 4360-78

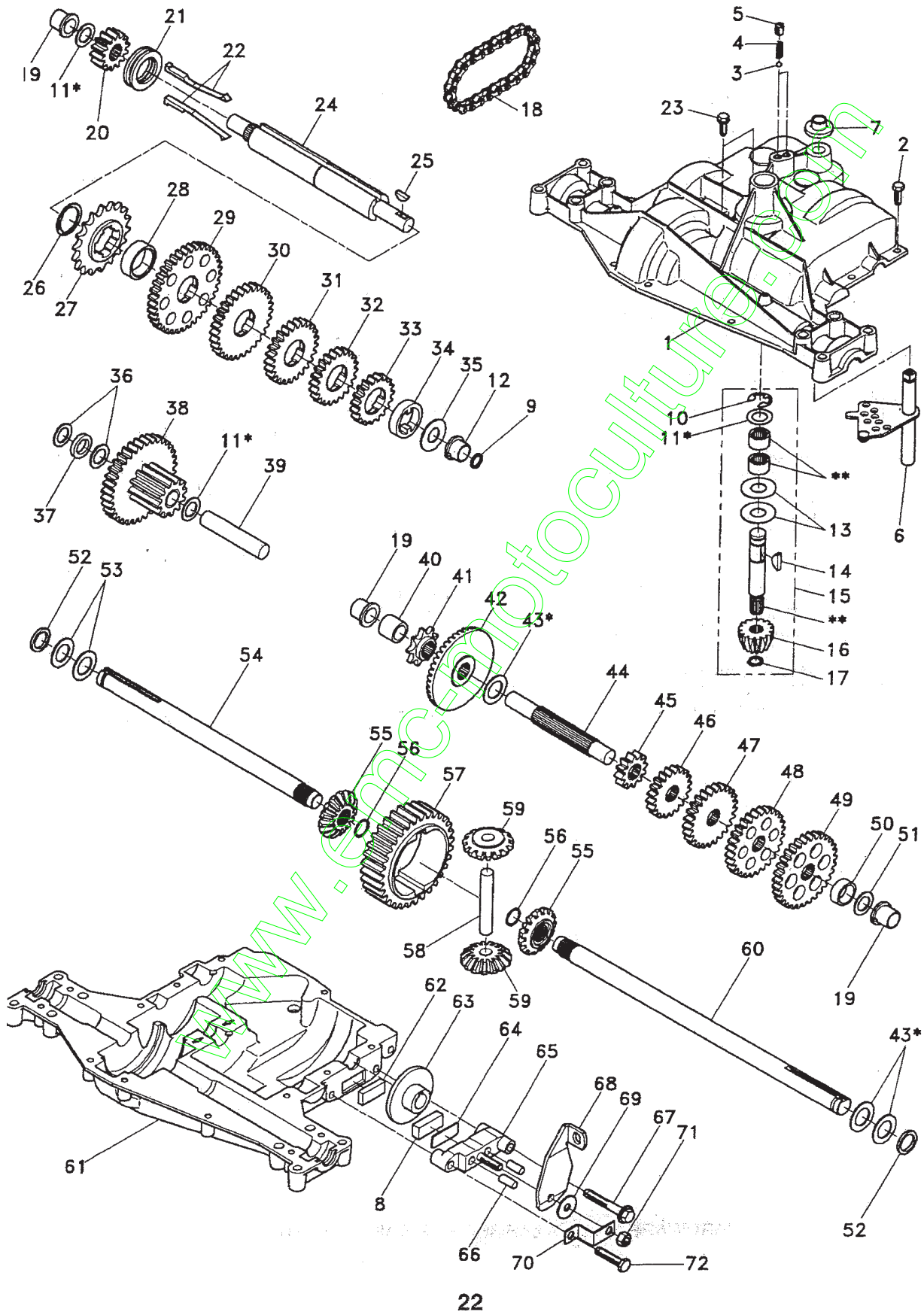

REPAIR PARTS

TRACTOR - - MODEL NUMBER UM1136D

DANA TRANSAXLE - MODEL NUMBER 4360-78

KEY PART NO. NO.	DESCRIPTION	KEY PART NO. NO.	DESCRIPTION
1 142671	Housing, Upper	41 105928X	Sprocket, 9 Teeth (Reverse)
2 2274J	Screw, Self-Tapping, Large 1/4-20 x .734	42 110084X	Gear, Bevel, 42 Teeth
3 134400	Ball, Detent	43 134394	* Assembly, Kit, Shim .750 Shaft
4 105904X	Spring, Detent	44 120473X	Shaft, Drive
5 105905X	Screw, Set	45 142678	Gear, Spur, 12 Teeth (1 st)
6 138235	Kit, Shifter Assembly	46 120407X	Gear, Spur, 20 Teeth (2 nd)
7 134399	Boot, Shifter	47 106589X	Gear, Spur, 25 Teeth (3 rd)
8 120951X	Puck, Friction	48 120408X	Gear, Spur, 28 Teeth (4 th)
9 143045	Seal, Oil	49 105937X	Gear, Spur, 31 Teeth (5 th)
10 142672	Ring, Retaining	50 105936X	Spacer .781 x 1.00 x .375
11 134793	* Assembly, Kit, Shim .625 Shaft	51 2226J	Washer, Plain .632 x 1.00 x .060
12 143051	Bearing, Flange	52 134401	Washer, Neoprene
13 120415X	Washer, Plain .632 x 1.38 x .046	53 2264J	Washer, Plain .758 x 1.25 x .031
14 142674	Key, Woodruff, #9	54 120474X	Axle, L.H.
15 138234	Assembly, Kit, Input Shaft	55 110081X	Gear, Miter, 15 Teeth
16 110078X	Pinion, Bevel, 14 Teeth	56 105941X	Ring, Retaining
17 105909X	Ring, Retaining	57 110071X	Gear, Spur, 32 Teeth
18 105910X	Chain, 24 Pitches	58 120952X	Shaft, Cross
19 105911X	Bearing, Flange	59 110082X	Gear, Miter, 15 Teeth
20 142675	Gear, Spur, 14 Teeth	60 120475X	Axle, R.H.
21 138246	Collar, Clutch	61 142680	Housing, Lower
22 138236	Assembly, Kit, Clutch Keys	62 120961X	Puck, Friction
23 134791	Screw, Tapping w/Sealer	63 7294J	Disc, Brake
24 142676	Shaft, Intermediate	64 108989X	Spacer
25 2244J	Key, Woodruff, #61	65 120953X	Jaw, Brake
26 105916X	Ring, Retaining	66 120954X	Pin, Dowel
27 120470X	Sprocket, 18 Teeth (Reverse)	67 134799	Screw, Self-Tapping, Large 5/16-18 x 2.25
28 110070X	Spacer	68 138244	Lever, Actuating
29 142677	Gear, Spur, 37 Teeth (1 st)	69 108996X	Washer, Plain .321 x 1.00 x .055
30 120405X	Gear, Spur, 30 Teeth (2 nd)	70 120956X	Bracket, Anti-Rotation
31 108980X	Gear, Spur, 25 Teeth (3 rd)	71 73810500	Locknut 5/16-24
32 120406X	Gear, Spur, 22 Teeth (4 th)	72 106596X	Screw, Self-Tapping, Large 5/16-18 x 1.44
33 134796	Gear, Spur, 19 Teeth (5 th)	73 120416X	Grease
34 134797	Spacer 1.133 x 1.50 x .375		
35 105925X	Washer, Plain .640 x 1.37 x .061		
36 2232J	Washer, Plain .632 x 1.00 x .026		
37 108978X	Spacer .630 x 1.00 x .169		
38 110079X	Assembly, Gear, Combination of 12 Teeth and 35 Teeth		
39 124639X	Shaft, Idler		
40 120472X	Spacer .635 x .875 x .755		

* Use in combinations to maintain proper clearances

** Order Key No. 15

NOTE: All component dimensions given in U.S. inches
1 inch = 25.4 mm

REPAIR PARTS

TRACTOR -- MODEL NUMBER UM1136D

BAGGER

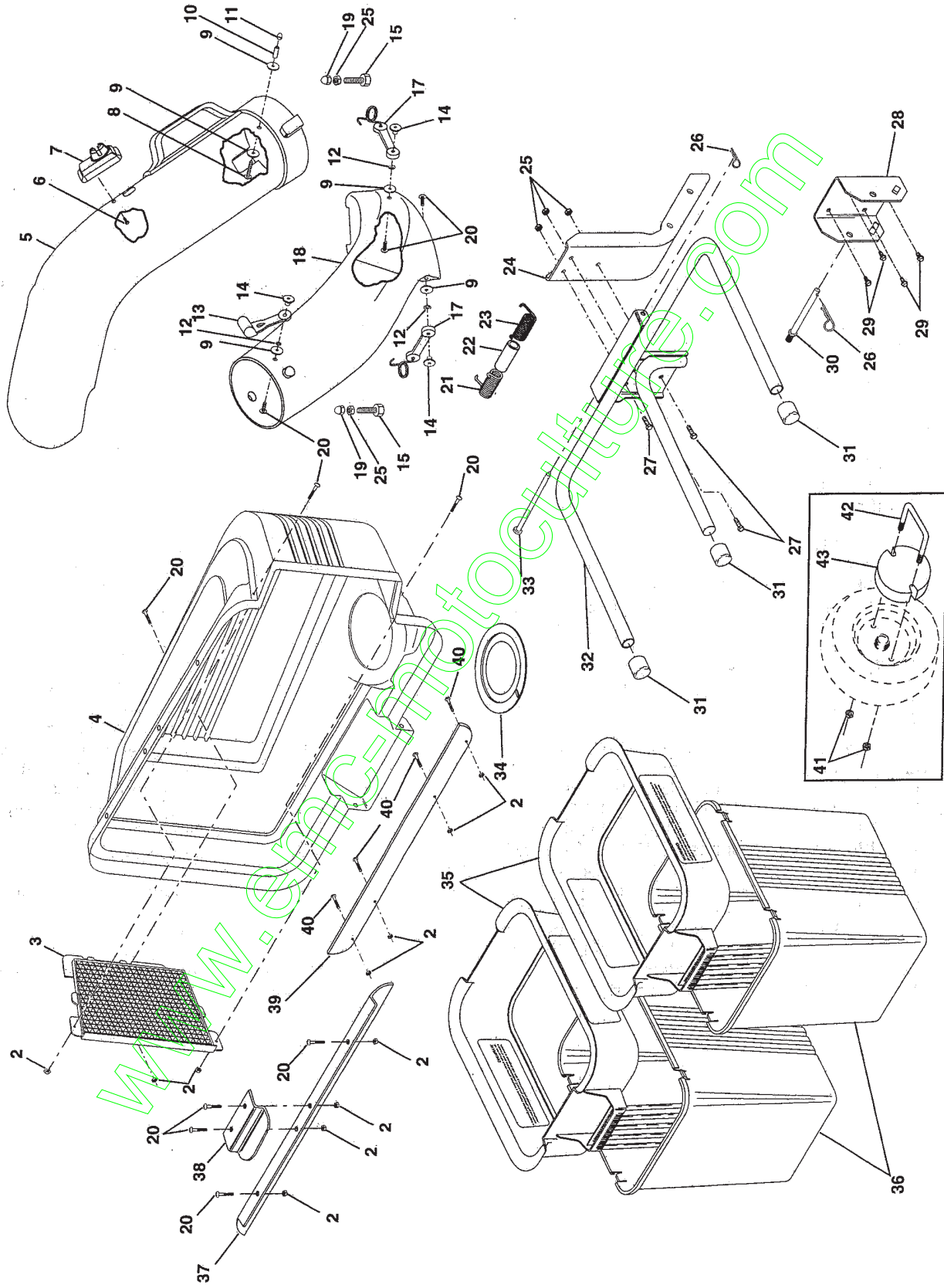

REPAIR PARTS

TRACTOR - - MODEL NUMBER UM1136D

BAGGER

KEY NO.	PART NO.	DESCRIPTION	KEY NO.	PART NO.	DESCRIPTION
2	69180	Locknut #10-24	25	63124	Locknut 5/16 x 18
3	127533	Screen, Cover	26	4939M	Spring, Retainer
4	140654	Cover	27	74760512	Bolt, Hex 5/16-18 x 3/4
5	128598	Chute, Upper	28	130889	Bracket, Mounting
6	18021008	Screw, Special	29	17490508	Screw, Thread Rolling 5/16-18 x 1/2
7	140572	Indicator, Dump Bag	30	131137	Pin, Support Post
8	87175	Screw, #10-24 x 1-1/8	31	134496	Cap, Tubing End
9	19061216	Washer 3/16 x 3/4 x 16 Ga.	32	126919X	Bagger, Frame
10	7206J	Spacer, Split	33	128600	Pin, Hinge
11	60867	Nut, Acorn #10-24	34	127534	Gasket, Cover
12	10071000	Washer, lock	35	129585	Container, Top
13	109808X	Latch, Chute	36	132431	Container, Bottom
14	2029J	Nut, Weld	37	132256	Seal, Cover
15	74930516	Bolt, Hex 5/16-18 x 1	38	130895	Latch Handle, Cover
17	130758	Latch Assy., Bagger	39	135495	Strip, Seal
18	128599	Chute, Lower	40	71141008	Screw #10-24 x 1/2
19	133841	Nut, Acorn 5/16-18	41	73800600	Locknut 3/8-16
20	71161010	Screw #10-24 x 5/8	42	137031	U-Bolt
21	132796	Spring, Cover L.H. (black)	43	123635X	Weight, Wheel
22	133235	Spacer, Cover	---	104419X	Bag, 3.0 mil. 30 Gallon Trash (not included with bagger)
23	132983	Spring, Cover R.H. (gray)	---	142001	Manual, Bagger Operator's
24	127720X	Post, Support			