

ILLUSTRATED PARTS LIST

MODEL NO. 96011002300

CUSTOMER CATALOG NO. UN15542SBHK

PRODUCT NO. 964 77 50-01

www.emc-motoculture.com

**TRACTOR-MODEL NO. UN15542SBHK (96011002300), PRODUCT NO. 964 77 50-01
SCHEMATIC**

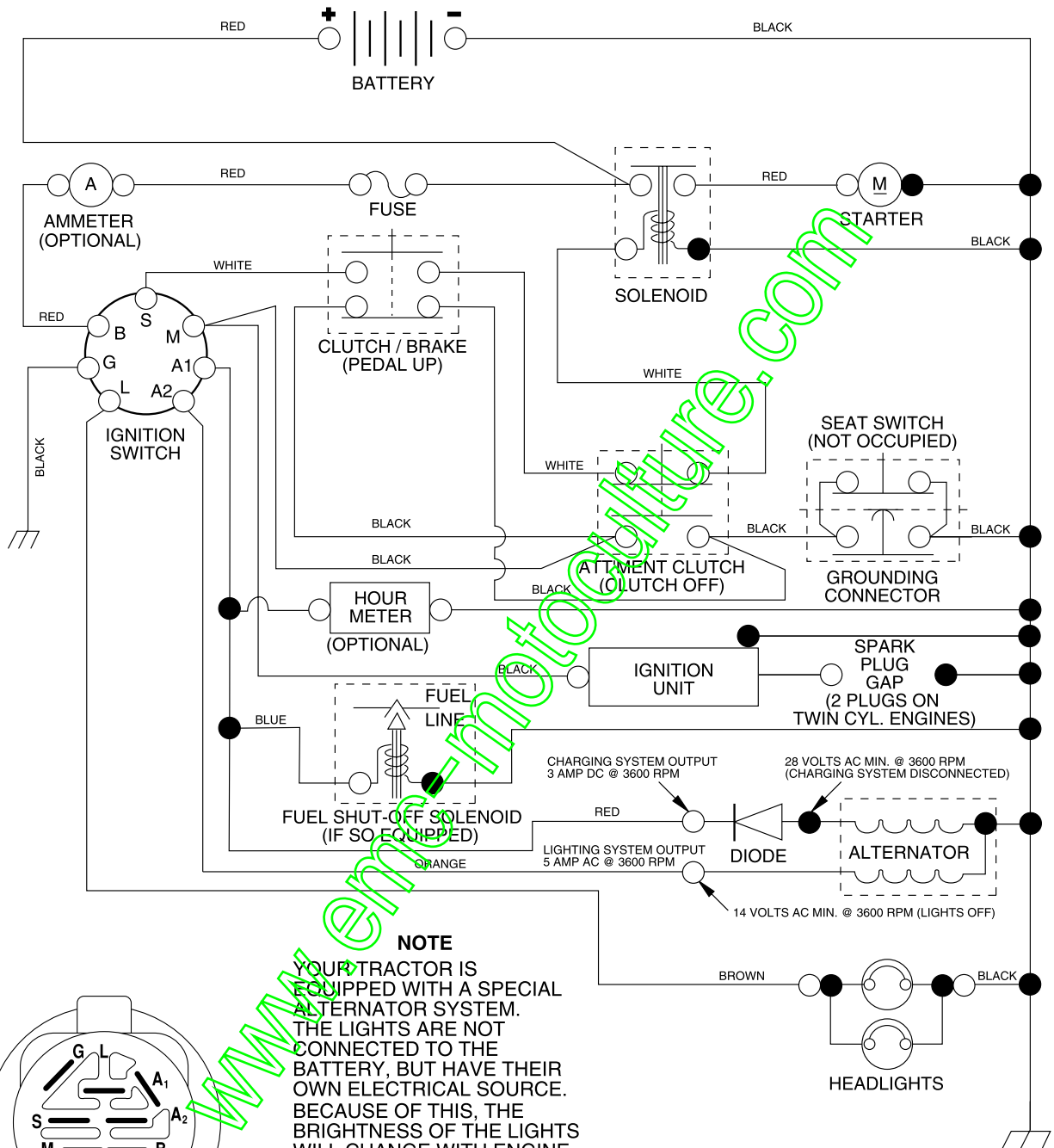

NOTE
YOUR TRACTOR IS EQUIPPED WITH A SPECIAL ALTERNATOR SYSTEM. THE LIGHTS ARE NOT CONNECTED TO THE BATTERY, BUT HAVE THEIR OWN ELECTRICAL SOURCE. BECAUSE OF THIS, THE BRIGHTNESS OF THE LIGHTS WILL CHANGE WITH ENGINE SPEED. AT IDLE THE LIGHTS WILL DIM. AS THE ENGINE IS SPEEDED UP, THE LIGHTS WILL BECOME THEIR BRIGHTEST.

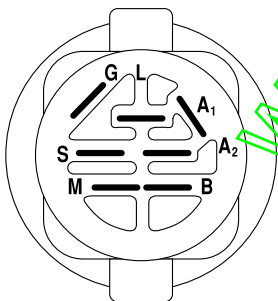

IGNITION SWITCH

POSITION	CIRCUIT	"MAKE"
OFF	M+G+A1	NONE
RUN/LIGHT	B+A1	A2+L
RUN	B+A1	NONE
START	B + S + A1	NONE

WIRING INSULATED CLIPS

NOTE: IF WIRING INSULATED CLIPS WERE REMOVED FOR SERVICING OF UNIT, THEY SHOULD BE REPLACED TO PROPERLY SECURE YOUR WIRING.

NON-REMOVABLE CONNECTIONS

REMOVABLE CONNECTIONS

REPAIR PARTS

TRACTOR-MODEL NO. UN15542SBHK (96011002300), PRODUCT NO. 964 77 50-01
ELECTRICAL

KEY NO.	PART NO.	DESCRIPTION
1	532 16 34-65	Battery 12 Volt 28 AMP
2	874 76 04-12	Bolt Hex Hd 1/4-20 unc x 3/4
8	532 17 66-89	Battery Box
16	532 17 61-38	Switch Interlock Push-In
21	532 18 37-59	Harness Asm Light W/4152j
22	532 00 41-52	Bulb Light #1156
24	532 12 47-80	Cable Battery 6 Ga. 11" red
25	532 14 61-47	Cable Battery 6 Ga. 44" red w/16 wire
26	532 17 51-58	Fuse 20 AMP
27	873 51 04-00	Nut Keps Hex 1/4-20 unc
28	532 12 47-73	Cable Ground 6 Ga. 12" black
29	532 12 13-05	Switch Seat
30	532 17 55-66	Switch Ign
33	532 14 04-01	Key Ign Molded Generic
40	532 17 97-20	Harness Ign.
41	871 11 04-08	Bolt Blk Fin Hex 1/4 - 20 x 1/2
42	532 13 15-63	Cover Terminal Red
43	532 17 88-61	Solenoid
48	532 14 08-44	Adapter Ammeter Rectangular
52	532 14 19-40	Protection Wire Loop
90	532 18 04-49	Cover Terminal Battery

NOTE: All component dimensions given in U.S. inches.
1 inch = 25.4 mm.

REPAIR PARTS

TRACTOR-MODEL NO. UN15542SBHK (96011002300), PRODUCT NO. 964 77 50-01
CHASSIS AND ENCLOSURES

KEY NO.	PART NO.	DESCRIPTION
1	532 17 46-19	Chassis Stamping
2	532 17 65-54	Drawbar
5	532 15 52-72	Bumper Hood/Dash
9	532 19 48-22	Dash
10	872 14 06-08	Bolt Carriage 3/8-16 x 1
11	532 17 49-96	Panel Dash Lh
13	532 18 69-52	Panel Dash Rh
14	817 49 06-08	Screw Thdrol 3/8-16 x 1/2
17	532 18 67-07	Hood
18	532 18 49-21	Bumper Hood
24	874 78 06-16	Bolt Fin Hex 3/8-16 unc x 1 Gr. 5
25	819 13 13-12	Washer 13/32 X 13/16 X 1/2 Ga.
26	873 80 06-00	Nut Lock Hex W/Ins 3/8-16 unc
28	532 18 82-24	Grille Asm. (Includes Key #'s 258, 259, 261, 263, 264)
30	532 19 57-70	Fender
31	532 13 66-19	Bracket Fender
33	532 18 11-93	Footrest LH
34	532 18 11-94	Footrest RH
35	872 11 06-06	Bolt Rdhd Sqnk 3/8-16 x 3/4
37	817 49 05-08	Screw Thdrol 5/16-18 x 1/2 TYT
38	532 17 57-10	Bracket Asm Pivot Mower Rear
39	532 17 47-14	Bracket Pivot Laser
58	532 15 01-27	Duct Air Engine
60	872 14 06-06	Bolt RD HD SQNK 3/8-1.6 UNC x 3/4
64	532 15 47-98	Dash Lower
74	873 68 06-00	Nut Lock 3/8-16 UNC
142	532 17 57-02	Plate Reinforcement
143	532 18 66-89	Bracket Swaybar Chassis
145	532 15 65-24	Rod Pivot Chassis/Hood
206	532 17 01-65	Bolt Shoulder 5/16-18 TT
207	817 67 05-08	Screw Thdrol 5/16-18 X 1/2
208	817 67 06-08	Screw Thdrol 3/8-16 x 1/2 TYT BI
209	817 00 06-12	Screw Hexwsh Thdr 3/8-16 x 3/4
258	532 18 97-55	Lens Grille Pro RH
259	532 18 97-54	Lens Grille Pro LH
261	532 18 97-53	Insert Grille Pro
263	532 18 38-33	Bezel Grille Pro RH
264	532 18 38-32	Bezel Grille Pro LH
278	532 19 16-11	Screw 10 x 3/4 Single Lead
-	532 00 54-79	Plug Button
--	532 19 39-35	Plug Switch Light

NOTE: All component dimensions given in U.S. inches
1 inch = 25.4 mm

REPAIR PARTS

TRACTOR-MODEL NO. UN15542SBHK (96011002300), PRODUCT NO. 964 77 50-01
DRIVE

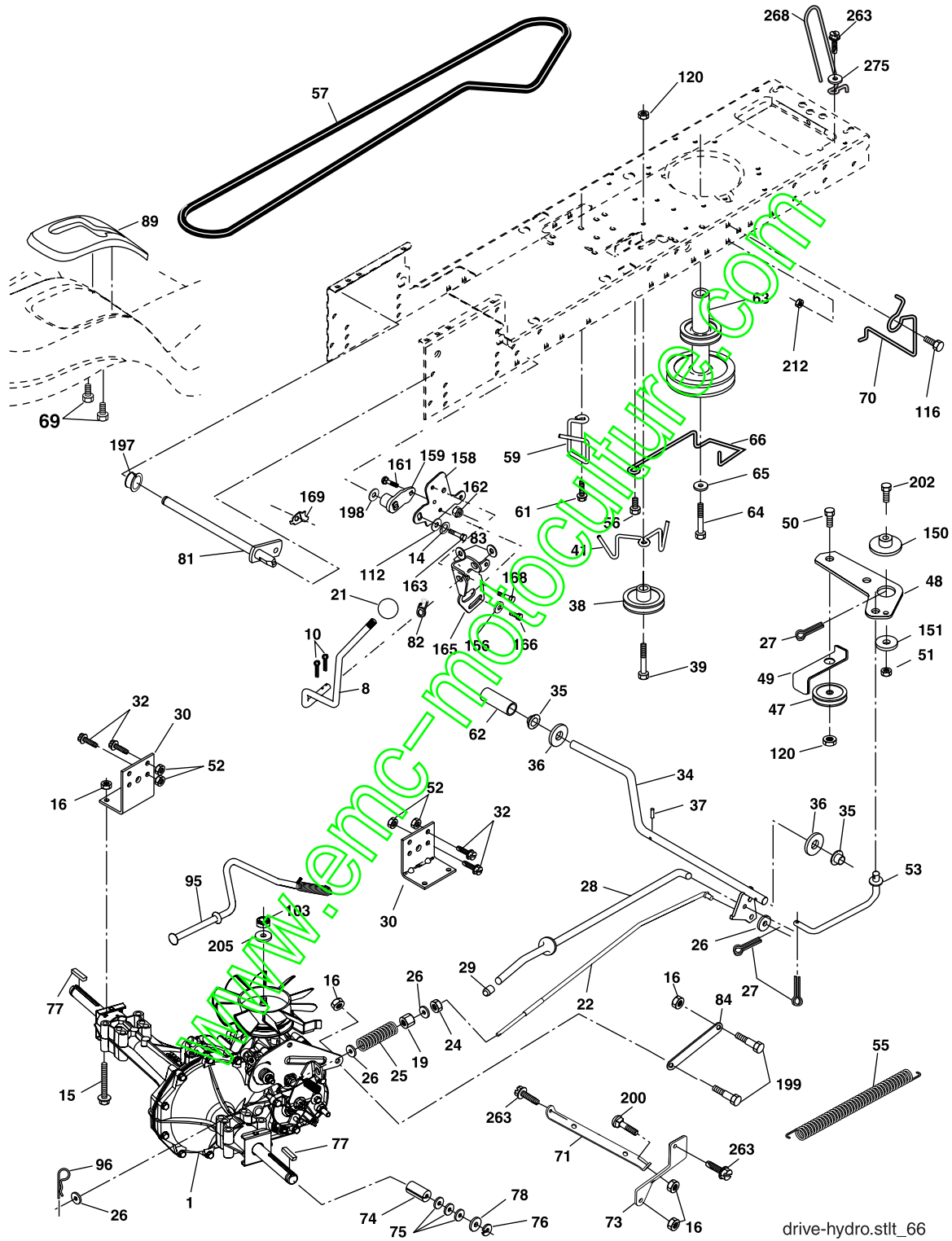

drive-hydro.stlt_66

REPAIR PARTS

TRACTOR-MODEL NO. UN15542SBHK (96011002300), PRODUCT NO. 964 77 50-01
DRIVE

KEY NO.	PART NO.	DESCRIPTION	KEY NO.	PART NO.	DESCRIPTION
1	-----	Transaxle Hydro Gr 322-0510 (Order parts from transaxle manufacturer)	70	532 18 02-18	Guide Belt Mower Drive RH
8	532 19 27-06	Rod Shift Fender	71	532 16 91-83	Strap Torque Lh Hydro
10	876 02 04-16	Pin Cotter 1/8 x 1 CAD	73	532 16 91-82	Strap Torque Rh Hydro
14	810 04 04-00	Washer Lock Hvy Helical 1/4	74	532 13 70-57	Spacer, Axle
15	874 49 05-44	Bolt Hex Flg Hd 5/16-18 x Gr.5	75	532 12 17-49	Washer 25/32 x 1-1/4 x 16 Gauge
16	873 80 05-00	Nut Lock Hex W/Ins. 5/16-18 unc P	76	812 00 00-01	E-Ring
19	873 80 06-00	Nut Lock Hex W/Wsh 3/8-16 unc	77	532 12 35-83	Key, Square
21	532 10 69-33	Knob	78	532 12 17-48	Washer 25/32 x 1-5/8 x 16 Gauge
22	532 16 94-98	Rod, Brake Hydro	81	532 16 55-96	Shaft Asm. Cross Hydro
24	873 35 06-00	Nut	82	532 16 57-77	Spring Torsion T/A
25	532 10 68-88	Spring, Brake Rod	83	819 17 12-16	Washer 17/32 x 3/4 x 16 Ga.
26	819 13 13-16	Washer	84	532 16 98-43	Link Transaxle
27	876 02 04-12	Pin Cotter 1/8 x 3/4 CAD.	89	532 19 49-72	Console, Shift
28	532 17 57-65	Rod, Parking Brake	95	532 17 02-01	Control Asm Bypass Hydro
29	532 07 16-73	Cap, Parking Brake	96	532 12 47-88	Retainer Spring 1" Zinc/Cad
30	532 17 49-73	Bracket, Transaxle	103	873 94 08-00	Nut Hex Jam Toplock 1/2-20 unf
32	874 76 05-12	Bolt Hex Hd 5/16-18 unc x 3/4	112	819 09 12-10	Washer 9/32 x 3/4 x 10 Ga.
34	532 17 55-78	Shaft, Foot Pedal	116	872 14 06-08	Bolt 3/8-16 Unc x 1
35	532 12 01-83	Bearing, Nylon	120	873 90 06-00	Nut Lock 3/8-16 Unc
36	819 21 16-16	Washer	150	532 17 54-56	Spacer Retainer
37	532 12 49-63	Pin, Roll	151	819 13 32-10	Washer 13/32 x 2 x 10 Ga.
38	532 17 91-14	Pulley, Idler, Composite	156	532 16 60-02	Washer Srrtd 5/16 ID x 1.0 x .125 Tk
39	872 11 06-22	Bolt RDHD 3/8-16 unc x 2-3/4 Gr. 5	158	532 16 55-89	Bracket Shift Mount
41	532 17 55-56	Keeper, Belt Idler	159	532 18 39-00	Hub Tapered Flange Shift LT
47	532 12 77-83	Pulley, Idler, V-Groove	161	872 14 04-06	Bolt Rdhd Sqnk 1/4-20 x 3/4 Gr. 5
48	532 15 44-07	Bellcrank Clutch Grnd Drv Stl	162	873 68 04-00	Nut Crownlock 1/4-20 Unc
49	532 12 32-05	Retainer, Belt	163	874 78 04-16	Bolt Hex Fin 1/4-20 unc x 1 Gr. 5
50	872 11 06-12	Bolt Carr. Sh 3/8-16 x 1-1/2 Gr. 5	165	532 16 56-23	Bracket Pivot Lever
51	873 68 06-00	Nut Crownlock 3/8-16	166	817 49 05-10	Screw 5/16-18 x 5/8
52	873 68 05-00	Nut Crownlock 5/16-18	168	532 16 54-92	Bolt Shoulder 5/16-18 x .561 TT
53	532 10 57-10	Link, Clutch	169	532 16 55-80	Plate Fastening
55	532 10 57-09	Spring, Return, Clutch	197	532 16 96-13	Nyliner Snap-In 5/8" ID
56	874 76 06-20	Bolt Fin Hex 3/8-16 unc x 1-1/4	198	532 16 95-93	Washer Nyl 7/8 ID x .105 HYD CRD
57	532 14 02-94	V-Belt, Ground Drive	199	532 16 96-12	Bolt Shoulder 5/16-18 unc
59	532 16 96-91	Keeper, Center Span	200	872 14 05-08	Bolt Rdhd Sqnk 5/16-18 unc x 1
61	817 12 06-14	Screw 3/8-16 x .875	202	872 11 06-14	Bolt Carr Sh 3/8-16 x 1-3/4 Gr. 5
62	532 12 48-72	Cover, Pedal	205	819 17 16-16	Washer 17/32 x 1 x 16 Ga.
63	532 18 02-19	Pulley, Eng	212	532 14 52-12	Nut Hexflange Lock
64	532 17 39-37	Bolt Hex 7/16-20 x 4 Gr. 5 - 1.5 THR	263	817 00 06-12	Screw Hex Wsh Thdr. 3/8-16 x 3
65	810 04 07-00	Washer	268	532 18 24-02	Guard Muffler RH
66	532 15 47-78	Keeper Belt Engine	275	819 13 16-14	Washer 13/32 x 1 x 14 Ga.
69	532 14 24-32	Screw Hex Wsh 1/4-1/2 unc			

NOTE: All component dimensions given in U.S. inches
1 inch = 25.4 mm

REPAIR PARTS

TRACTOR-MODEL NO. UN15542SBHK (96011002300), PRODUCT NO. 964 77 50-01
STEERING ASSEMBLY

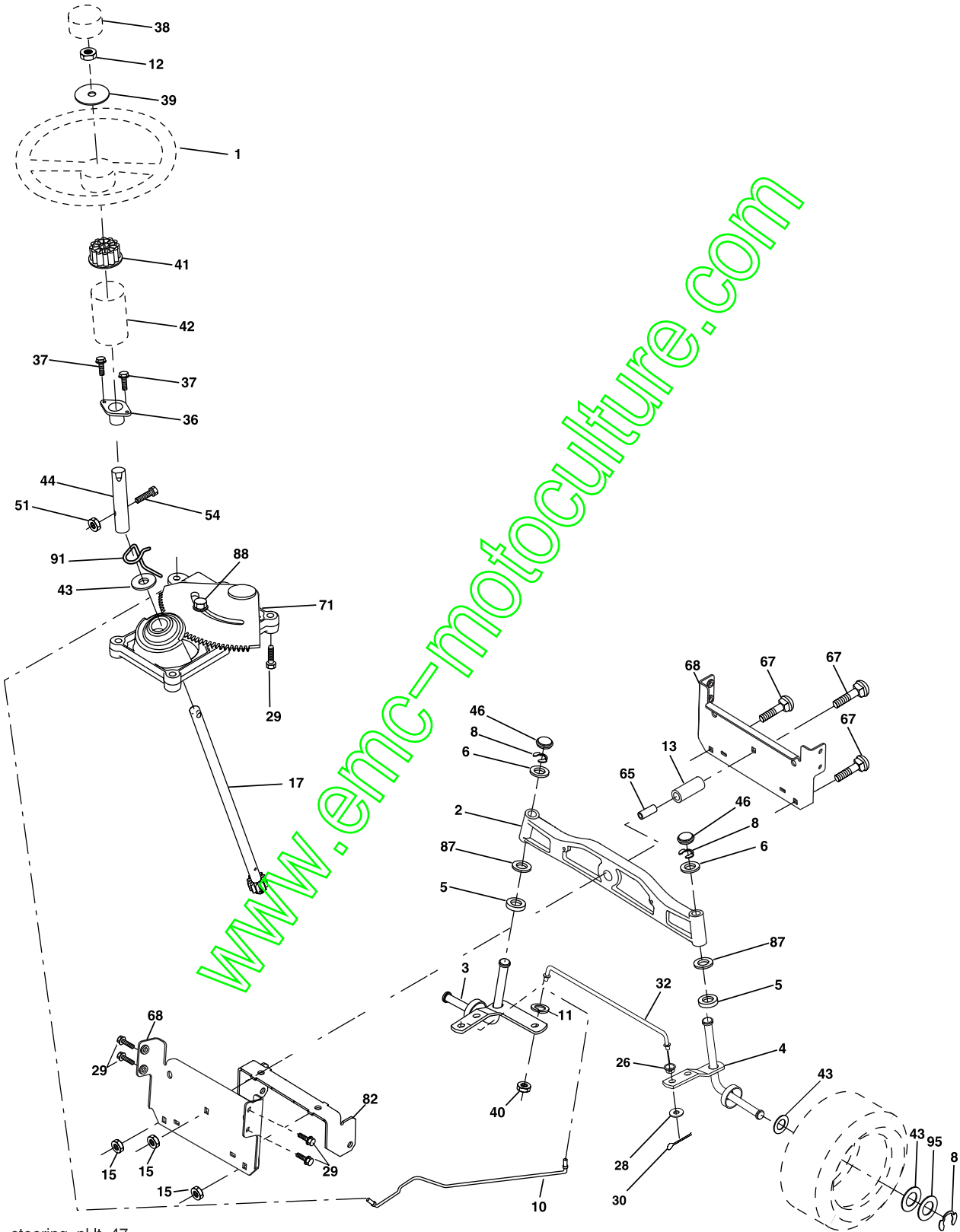

steering_pl.lt_47

REPAIR PARTS

TRACTOR-MODEL NO. UN15542SBHK (96011002300), PRODUCT NO. 964 77 50-01
STEERING ASSEMBLY

KEY NO.	PART NO.	DESCRIPTION
1	532 19 45-95	Wheel Steering
2	532 18 47-06	Axle Asm
3	532 16 98-40	Spindle Asm LH
4	532 16 98-39	Spindle Asm RH
5	532 12 49-31	Bearing Race Thrust Harden
6	532 12 17-48	Washer 25/32 X 1-5/8 X 16 Ga
8	812 00 00-29	Ring Klip #t5304-75
10	532 17 51-21	Link Drag
11	810 04 06-00	Washer Lock Hvy Hlcl Spr 3/8
12	873 94 08-00	Nut Hex Jam Toplock 1/2-20 Unf
13	532 13 65-18	Spacer Brg Axle Front
15	532 14 52-12	Nut Hex Flange Lock
17	532 18 06-41	Shaft Asm Strg
26	532 12 68-47	Bushing Link Drag Blk LR
28	819 13 14-16	Washer 13/32 X 7/8 X 16 Ga
29	817 00 06-12	Screw 3/8-16x3/4
30	876 02 04-12	Pin Cotter 1/8 X 3/4 Cad
32	532 19 27-57	Rod Tie
36	532 15 50-99	Bushing Strg
37	532 15 29-27	Screw
38	532 19 46-03	Cap Strg Wh
39	819 18 38-12	Washer 9/16 ID x 2-3/8 OD 12 Ga.
40	873 54 06-00	Nut Crownlock 3/8-24
41	532 18 67-37	Adaptor Wheel Strg
42	532 16 96-33	Boot Steering Shaft
43	532 12 17-49	Washer 25/32 X 1-1/4 X 16 Ga
44	532 18 06-40	Extension Steering Shaft
46	532 12 12-32	Cap Spindle Fr Top Blk
51	873 54 04-00	Nut Crownlock 1/4-28
54	871 13 04-20	Bolt Hex 1/4-28 Unf x 1-1/4 Gr. 8
65	532 16 03-67	Spacer Brace Axle
67	872 11 06-18	Bolt, Rdhd Sqnk 3/8-16 x 2-1/4
68	532 16 98-27	Axle, Brace
71	532 17 51-46	Steering Asm.
82	532 16 98-35	Bracket Susp Chassis Front
87	532 17 39-66	Washer Flat
88	532 17 51-18	Bolt Shoulder 7/16-20
91	532 17 55-53	Clip Steering
95	532 18 89-67	Washer Harden .739 x 1.637 x 060

NOTE: All component dimensions given in U.S. inches.
1 inch = 25.4 mm.

REPAIR PARTS

TRACTOR-MODEL NO. UN15542SBHK (96011002300), PRODUCT NO. 964 77 50-01
ENGINE

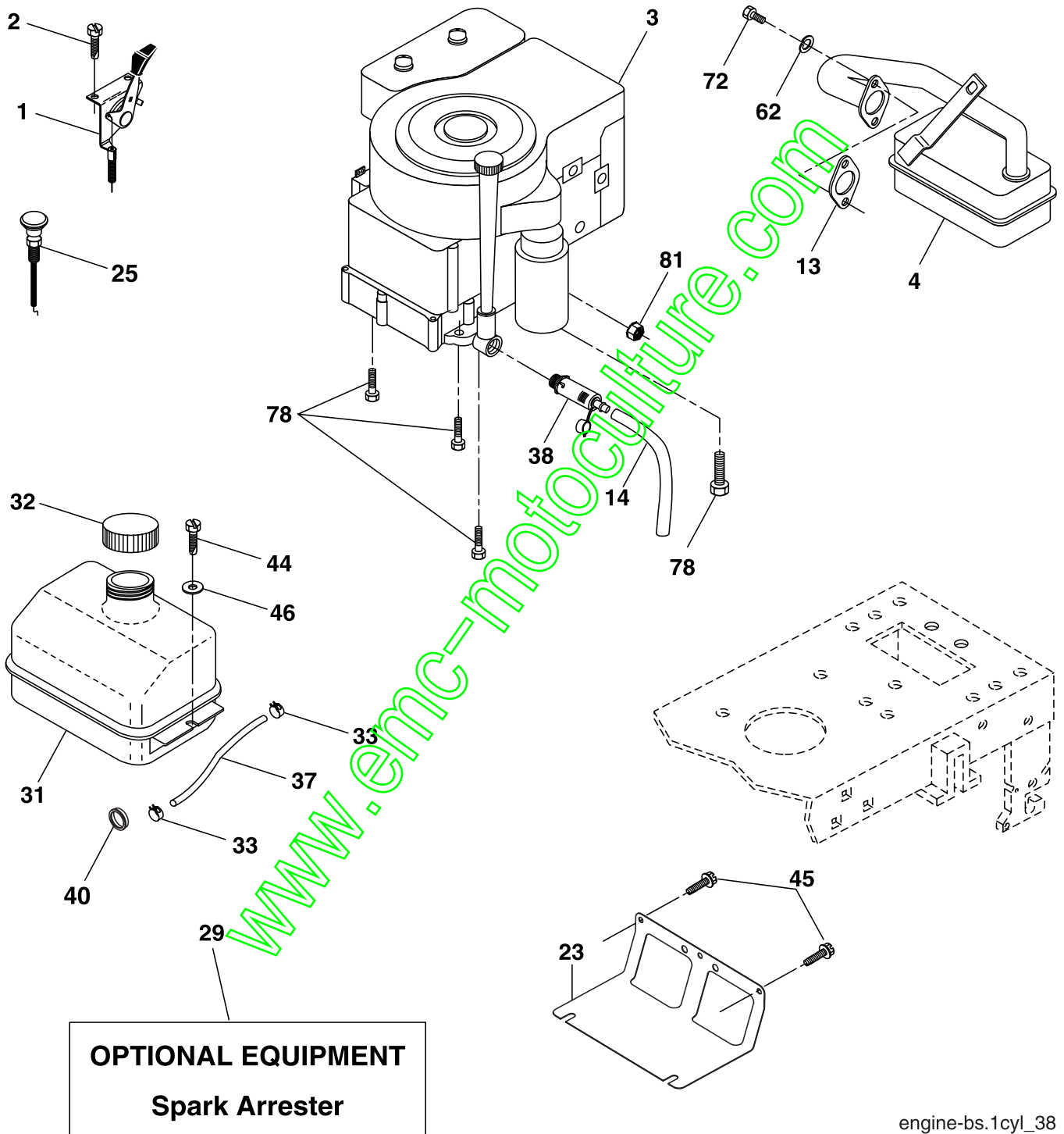

engine-bs.1cyl_38

REPAIR PARTS

TRACTOR-MODEL NO. UN15542SBHK (96011002300), PRODUCT NO. 964 77 50-01
ENGINE

KEY NO.	PART NO.	DESCRIPTION
1	532 17 05-51	Control Th/ch Flag
2	817 72 04-08	Screw Hex Thd Cut 1/4-20 x 1/2
3	-----	Engine B&S Model No. 282H07 (Order Parts From Engine Manufacturer)
4	532 13 73-52	Muffler
13	532 16 52-91	Gasket Eng 1 313 Id Tin Plated
14	532 14 84-56	Tube Drain Oil Easy
23	532 16 98-37	Shield Brn/Dbr Guard
25	532 19 06-95	Control Choke
29	532 13 71-80	Kit Spark Arrestor (Flat Scrn)
31	532 18 77-50	Tank Fuel Front
32	532 14 05-27	Cap Asm Fuel W/sym Vented
33	532 12 34-87	Clamp Hose Black
37	532 13 70-40	Line Fuel 20"
38	532 18 16-54	Plug Drain Oil Easy
40	532 12 40-28	Bushing Snap Nyl Blk Fuel Line
44	817 67 04-12	Screw Hexwsh Thdrol 1/4-20x3/4
45	817 00 06-12	Screw Hex Wsh Thdrol 3/8-16 x 3/4
46	819 09 14-16	Washer 9/32 X 7/8 X 16 Ga
62	810 01 05-00	Washer Split
72	871 07 05-12	Screw Hex Hd Cap 5/16-18 x 3/4
78	817 06 06-26	Screw 3/8-16x1-1/4
81	873 51 04-06	Nut 1/4-20

NOTE: All component dimensions given in U.S. inches
1 inch = 25.4 mm

REPAIR PARTS

TRACTOR-MODEL NO. UN15542SBHK (96011002300), PRODUCT NO. 964 77 50-01
SEAT ASSEMBLY

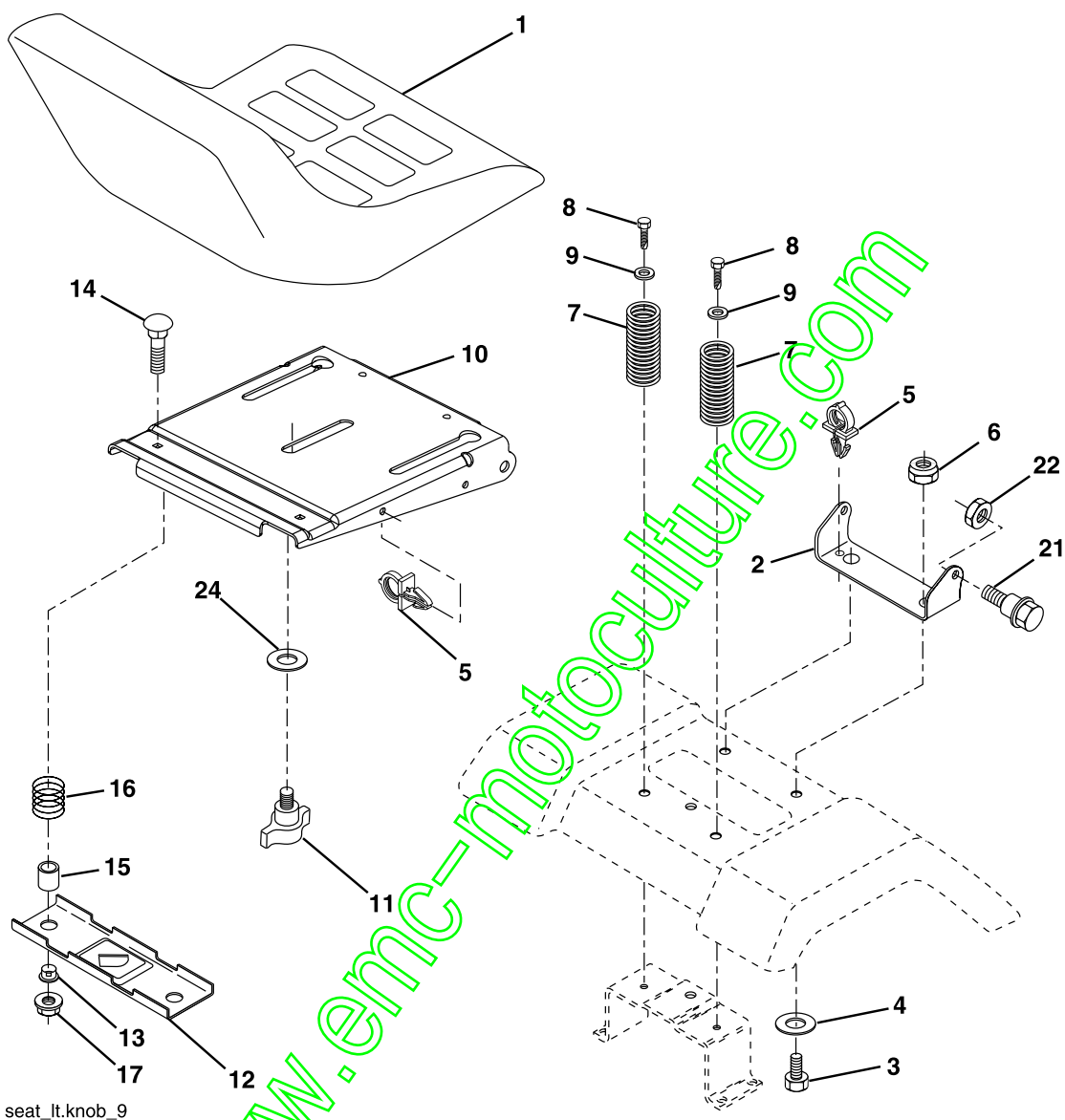

seat_lt.knob_9

KEY NO.	PART NO.	DESCRIPTION
1	532 18 87-06	Seat
2	532 18 01-66	Bracket Pivot Seat
3	871 11 06-16	Bolt Fin Hex 3/8-16unc X 1
4	819 13 16-10	Washer 13/32 X 1 X 10 Ga
5	532 14 50-06	Clip Push-In
6	873 80 06-00	Nut Hex w/Ins. 3/8-16 Unc
7	532 12 41-81	Spring Seat Cprsn 2 250 Blk Zi
8	817 00 06-16	Screw 3/8-16 X 1-1/2
9	819 13 16-14	Washer 13/32 X 1 X 14 Ga.
10	532 18 01-86	Pan Seat
11	532 16 63-69	Knob Seat

KEY NO.	PART NO.	DESCRIPTION
12	532 12 12-46	Bracket Mounting Switch
13	532 12 12-48	Bushing Snap Blk Nyl 50 Id
14	872 05 04-12	Bolt Rdhd Sqnk 1/4-20x1-1/2
15	532 12 12-49	Spacer Split
16	532 12 37-40	Spring Cprsn
17	532 12 39-76	Nut Lock 1/4 Lge Flg Gr 5 Zinc
21	532 17 18-52	Bolt Shoulder 5/16-18 Unc
22	873 80 05-00	Nut Hex Lock W/Ins 5/16-18
24	819 17 19-12	Washer 17/32 X 1-3/16 X 12 Ga.

NOTE: All component dimensions given in U.S. inches.
1 inch = 25.4 mm

REPAIR PARTS

TRACTOR-MODEL NO. UN15542SBHK (96011002300), PRODUCT NO. 964 77 50-01
DECALS

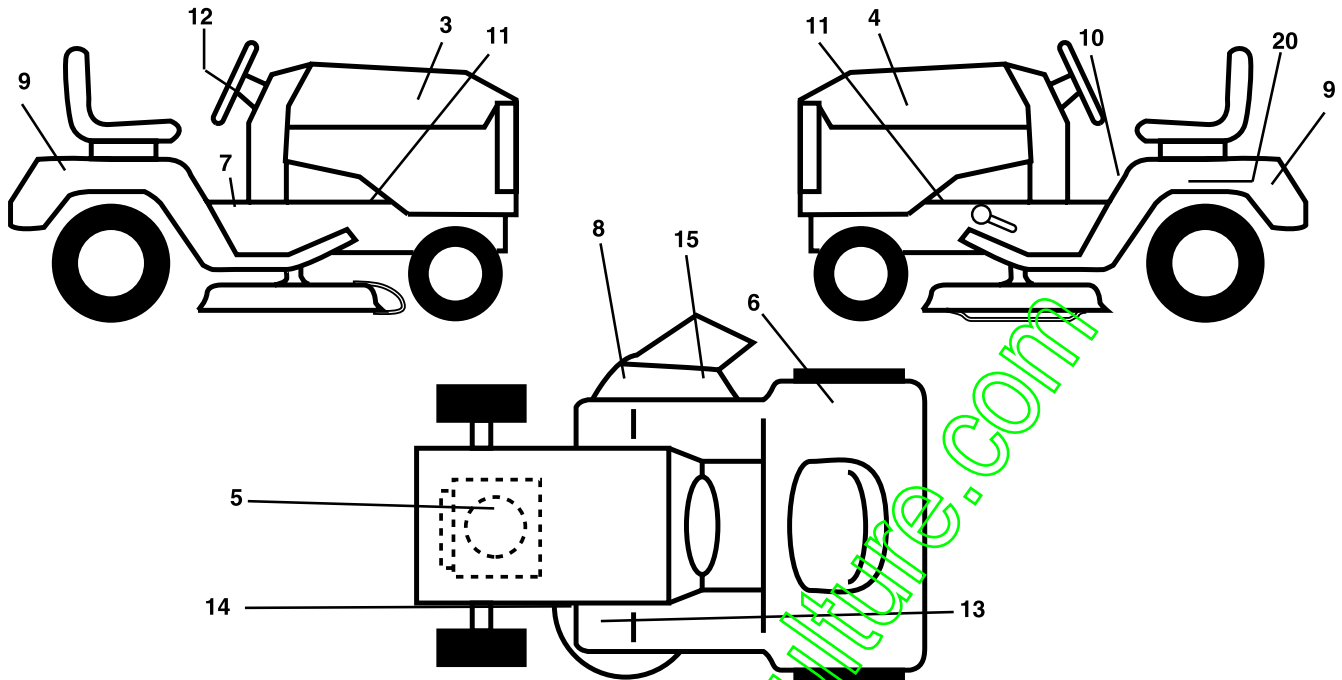

KEY NO.	PART NO.	DESCRIPTION
3	532 18 96-05	Decal Hood RH
4	532 18 96-06	Decal Hood LH
5	532 18 47-69	Decal HP Engine
6	532 18 04-32	Decal Fender 100 DB/CE
7	532 14 08-37	Decal Saddle Brake
8	532 17 91-28	Decal Deck "B" 42"
9	532 18 96-12	Decal Fender Sides
10	532 14 54-98	Decal Read Owner's Manual Syms.
11	532 15 97-36	Decal Chassis Hot Muffler
12	532 18 96-11	Decal Wheel Steering

KEY NO.	PART NO.	DESCRIPTION
13	532 15 97-37	Decal Brake/Clutch Symbol LT
14	532 16 03-96	Decal V-Belt Schematic
15	532 18 21-66	Decal Mower Cutfingher Symbol
20	532 14 50-05	Decal Bat Dan/Psn
--	532 16 25-98	Decal Drawbar Load Limit
--	532 16 69-60	Decal By-Pass Lt Hydro
--	532 13 83-11	Decal Handle Lft Height Adjust
--	532 18 52-36	Manual Operator's (Euro.)

WHEELS & TIRES

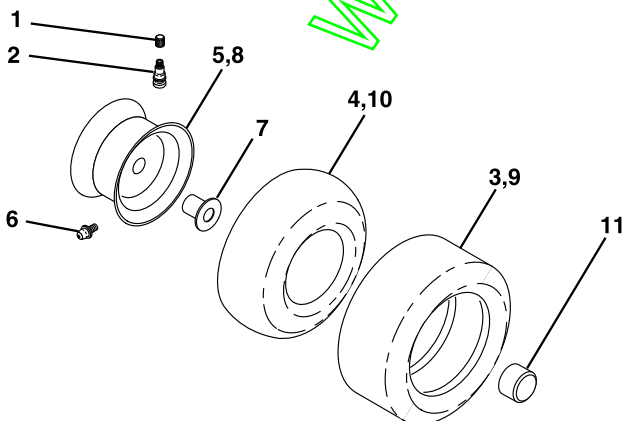

KEY NO.	PART NO.	DESCRIPTION
1	532 05 91-92	Cap Valve Tire
2	532 06 51-39	Stem Valve
3	532 12 41-57	Tire F Ts 15 X 6 0 - 6 Service
4	532 05 99-04	Tube Front (Service Item Only)
5	532 18 33-37	Rim Asm 6"front Service
6	532 12 49-57	Fitting Grease (Front Wheel Only)
7	532 12 49-59	Bearing Flange (Front Wheel Only)
8	532 18 33-38	Rim Asm 8"rear Service
9	532 12 39-69	Tire R Ts 18 x 8.5-8 C Service
10	532 12 49-26	Tube Rear (Service Item Only)
11	532 17 50-39	Cap Axle Blk 1 50 X 1 00
--	532 14 43-34	Sealant, Tire (10 oz. Tube)

NOTE: All component dimensions given in U.S. inches
1 inch = 25.4 mm

REPAIR PARTS

TRACTOR-MODEL NO. UN15542SBHK (96011002300), PRODUCT NO. 964 77 50-01
MOWER DECK

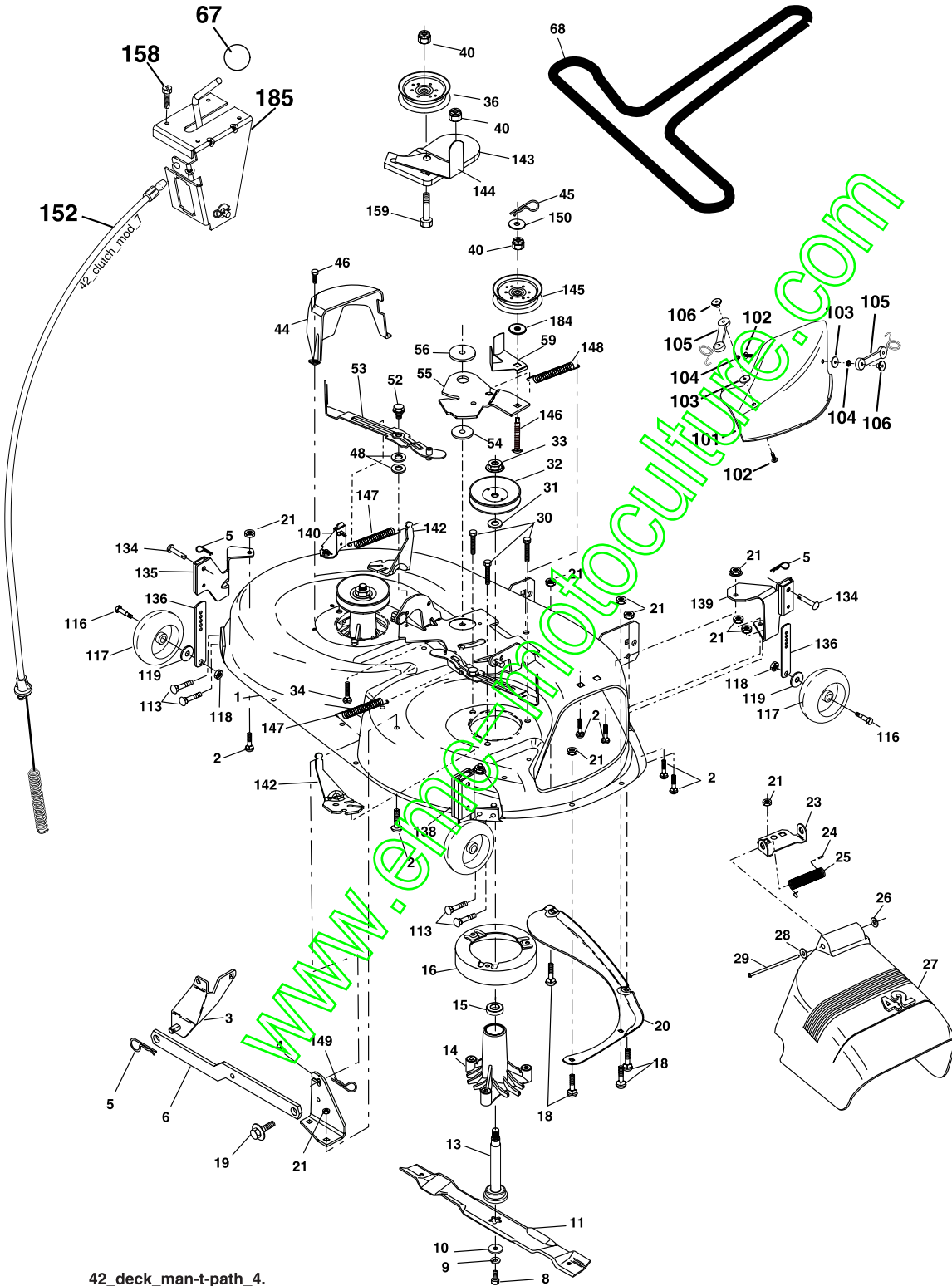

42_deck_man-t-path_4.

REPAIR PARTS

TRACTOR-MODEL NO. UN15542SBHK (96011002300), PRODUCT NO. 964 77 50-01
MOWER DECK

KEY NO.	PART NO.	DESCRIPTION	KEY NO.	PART NO.	DESCRIPTION
1	532 18 20-32	Deck Asm 42"weldment	68	532 18 02-15	V-Belt Mower 42"
2	872 14 05-06	Bolt Rdhd Sqnk 5/16-18unc X3/4	101	532 13 64-20	Cover Mulching
3	532 13 80-17	Bracket Asm Fr Sway Bar 38/42	102	871 08 10-10	Washer Lock #10
4	532 16 54-60	Bracket Asm Deck 42"sway Bar	103	819 06 12-16	Washer #10
5	532 12 46-70	Retainer Spring	104	810 07 10-00	Screw Pan Head Phillip 10-24 x 5/8
6	532 17 80-24	Bar Sway Deck	105	532 16 07-93	Latch Asm.
8	532 85 08-57	Bolt 3/8 - 24 X 1.25 Gr 8	106	532 12 50-04	Nut Weld
9	810 03 06-00	Washer Lock Hvy 3/8	113	817 00 05-10	Screw 5/16-18 x 3/4
10	532 14 02-96	Washer Hard Blade Mower Vented	116	532 19 34-06	Bolt Shoulder 3/8-16 x 3-5/8
11	532 13 41-49	Blade 42" Mulching Std (For mulching mowers only)	117	532 17 48-73	Wheel Gauge
13	532 13 76-45	Shaft Asm W/lower Bearing	118	873 93 06-00	Nut Centerlock 3/8-16
14	532 12 87-74	Housing Mandrel Vented	119	819 12 14-14	Washer 3/8 x 7/8
15	532 11 04-85	Bearing Ball Mandrel	134	532 15 69-41	Pin Head Rivet
16	532 17 44-93	Stripper Mower Vented	135	532 15 97-65	Bracket Asm Whl Ga. Rear LH
18	872 14 05-05	Bolt Rdhd Sqnk 5/16-18 X 5/8	136	532 15 59-86	Bar Adjusting Guage Wheel
19	532 13 28-27	Bolt Shoulder	138	532 15 97-63	Bracket Asm Whl Ga. Rear RH
20	532 15 97-70	Baffle Vortex 42	139	532 15 97-67	Bracket Asm Whl Ga. Front RH
21	873 68 05-00	Nut Crownlock 5/16-18 UNC	140	532 15 97-68	Bracket Asm Whl Ga. Front LH
23	532 17 75-63	Bracket Deflector Mower 42"	142	532 16 58-90	Arm Spring Brake Mower
24	532 10 53-04	Cap Sleeve 80x 112 Blk Mower	143	532 15 71-09	Bracket Arm Idler 42"
25	532 12 37-13	Spring Torsion Deflector 2 52	144	532 15 86-34	Keeper Belt 42" Clutch Idler
26	532 11 04-52	Nut Push Phos & Oil	145	532 16 58-88	Pulley Idler Flat
27	532 17 18-59	Shield Deflector Mower 42" Blk	146	532 17 19-77	Bolt Carriage Idler
28	819 11 10-16	Washer 11/32 X 5/8 X 16 Ga	147	532 17 97-48	Spring Extension
29	532 13 14-91	Rod Hinge 42"6 75 Wlg	148	532 16 90-22	Spring Return Idler
30	532 17 39-84	Screw Thd Rolling Washer Head	149	532 16 98-98	Retainer Spring Yellow
31	532 18 76-90	Washer Spacer	150	819 09 12-10	Washer 9/32 x 3/4 x 10 Ga.
32	532 15 35-35	Pulley Mandrel 42"	152	532 18 15-55	Clutch Cable 42"
33	532 17 83-42	Nut 9/16 Toplock Fling Oil Dip	158	817 72 04-08	Screw Hex Thd Cut 1/4-20 x 1/2
34	872 11 06-12	Bolt Carr Sh 3/8-16 x 1-1/2 Gr.5	159	872 14 06-14	Bolt Rdhd Sqn 3/8-16 unc x 1-3/4
36	532 13 14-94	Pulley Idler Flat 3 060	184	819 13 14-10	Washer 13/32 x 7/8 x 10 Ga.
40	873 90 06-00	Nut Lock FLG 3/8-16 unc	185	532 18 82-34	Head Asm Cable Clutch
44	532 14 00-88	Guard Mandrel LH Black	--	532 13 07-94	Mandrel Asm Service (Includes Housing, Shaft and Shaft Hardware Only-Pulley Not Included)
45	532 12 47-88	Spring Retainer 1" Zinc/cad	--	532 18 76-94	Replacement Mower, Complete (Std. deck-order separately mulch cover and gauge wheel components Key Nos. 101-106, 116-119,5, 134)
46	532 13 77-29	Screw Hex Thd Cut 1/4-20x5/8 T			
48	532 13 39-44	Washer Hardened Smaller			
52	532 13 98-88	Bolt Shoulder 5/16-18 Unc Blkz			
53	532 18 49-07	Arm Asm Pad Brake			
54	532 17 85-15	Washer Hardened			
55	532 15 50-46	Arm Idler 42" mower LT/YT			
56	532 16 57-23	Spacer Retainer Mower			
59	532 14 10-43	Guard TUV Idler			
67	532 10 69-32	Knob Rd 3/8-16 Plstc Thds Blk			

NOTE: All component dimensions given in U.S. inches
1 inch = 25.4 mm

REPAIR PARTS

TRACTOR-MODEL NO. UN15542SBHK (96011002300), PRODUCT NO. 964 77 50-01
MOWER LIFT

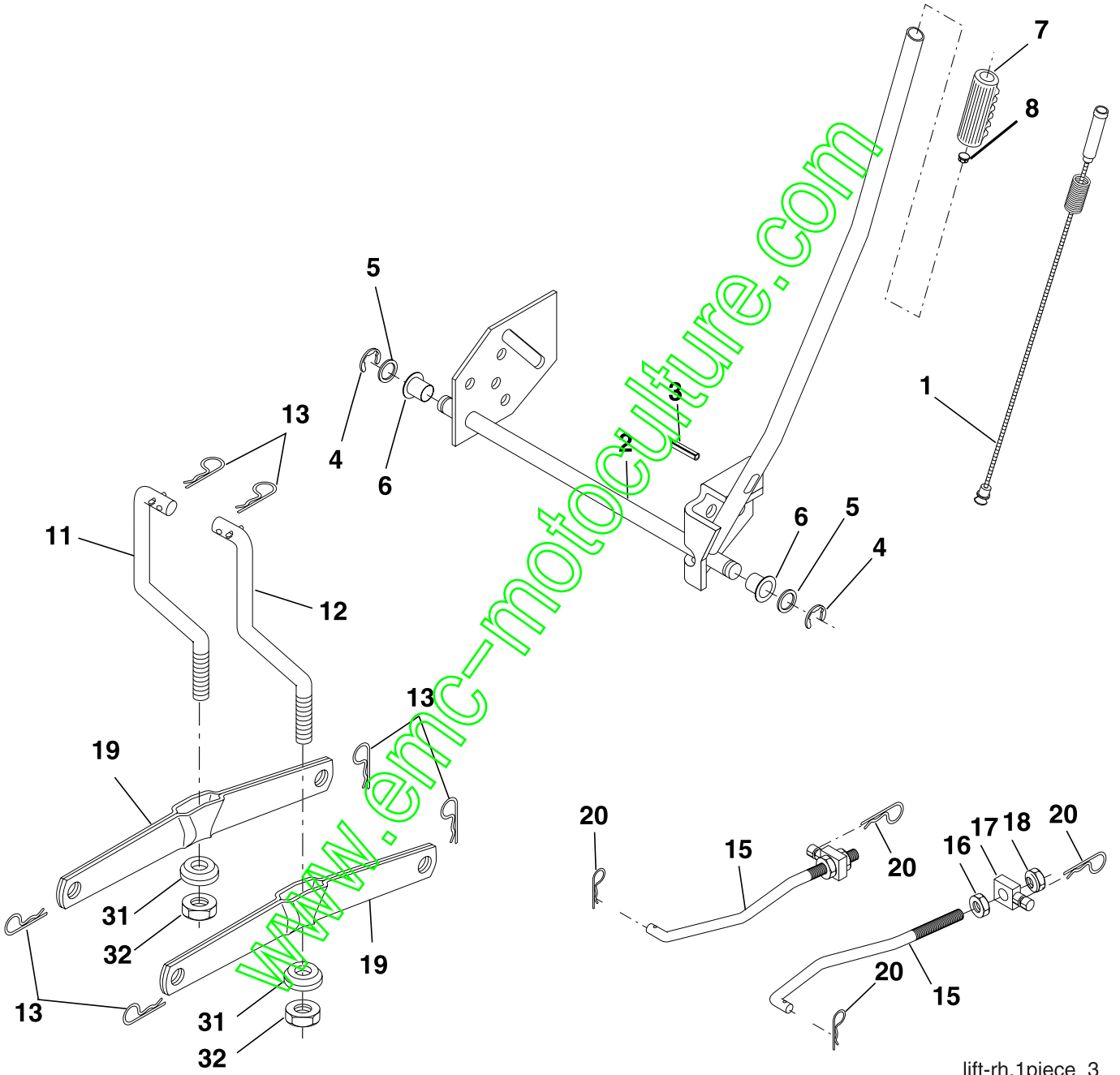

lift-rh.1piece_3

REPAIR PARTS

TRACTOR-MODEL NO. UN15542SBHK (96011002300), PRODUCT NO. 964 77 50-01
MOWER LIFT

KEY NO.	PART NO.	DESCRIPTION
1	532 15 94-61	Wire Asm Inner W/plunger 17 32
2	532 15 94-76	Shaft Asm Lift LH Inf Hgt P/L
3	532 18 88-22	Pin Groove
4	812 00 00-02	E Ring #5133-62
5	819 21 16-21	Washer 21/32 X 1-X 21 Ga
6	532 12 01-83	Bearing Nylon Blk 629 Id
7	532 10 94-13	Grip Handle
8	532 12 45-26	Button Plunger
11	532 13 98-65	Link Lift LH
12	532 13 98-66	Link Lift RH
13	532 12 46-70	Retainer Spring
15	532 17 32-88	Link Front
16	873 35 08-00	Nut Jam Hex 1/2-13 Unc
17	532 17 56-89	Trunnion Blk Zinc
18	873 80 08-00	Nut Lock W/wsh 1/2-13unc
19	532 13 98-68	Arm Suspension Rear
20	532 16 35-52	Retainer Spring
31	532 16 98-65	Bearing pvt. Lift
32	873 54 06-00	Nut Crownlock 3/8-24

NOTE: All component dimensions given in U.S. inches
1 inch = 25.4 mm

www.emc-motoculture.com