

Colombia

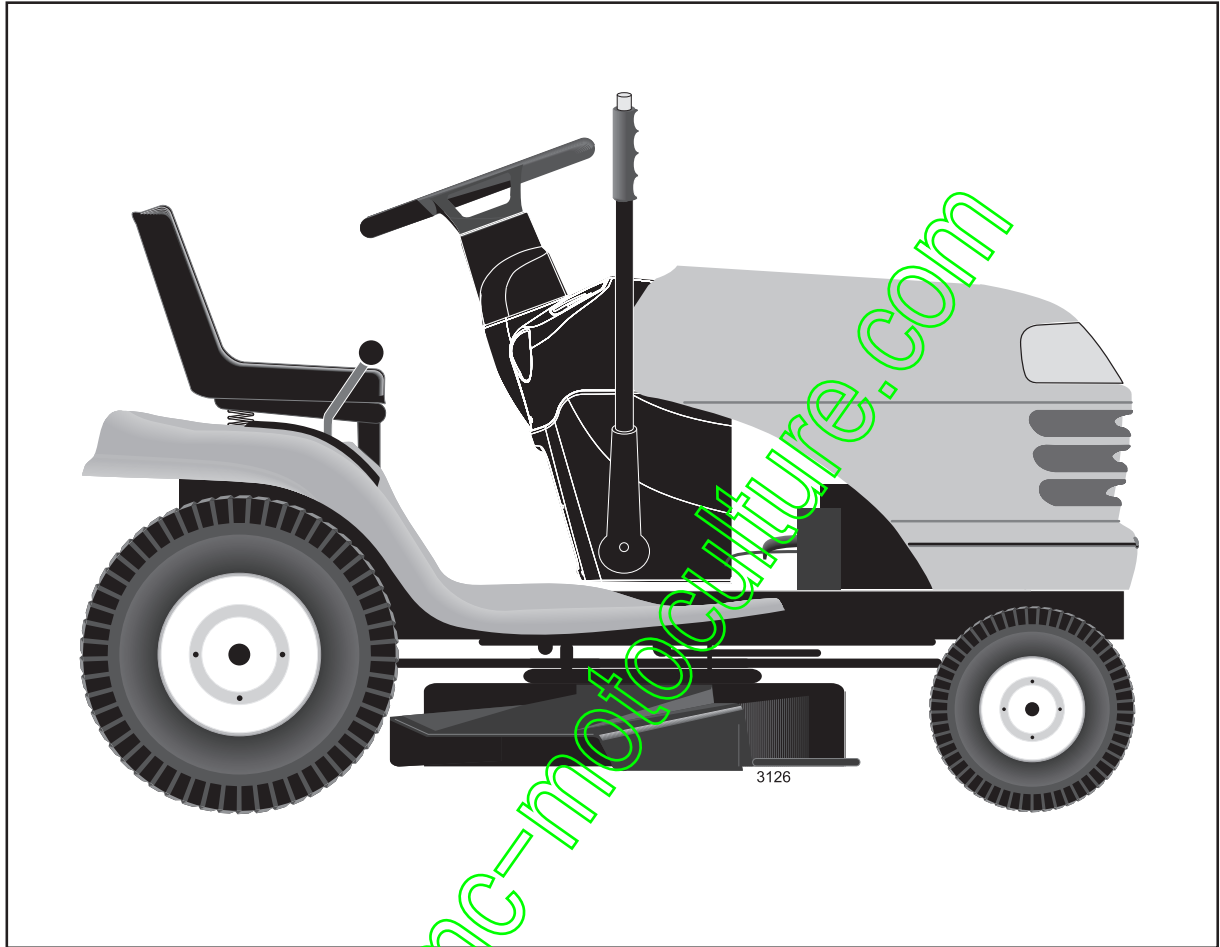

Venus

Repair Parts Manual

REPAIR PARTS

TRACTOR -- MODEL NUMBER VENUS (96011026001), PRODUCT NO. 960 11 02-60
DECALS

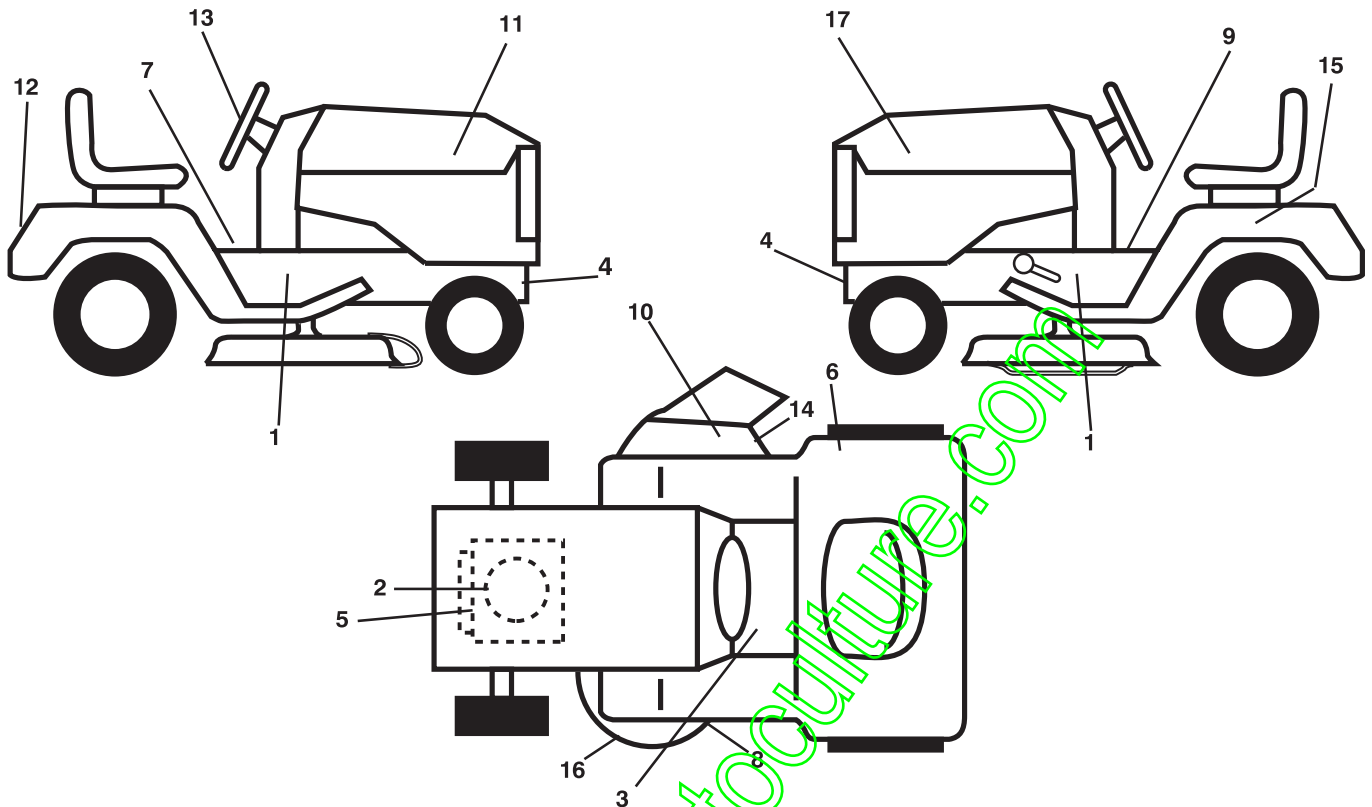

KEY NO.	PART NO.	DESCRIPTION
1	532 19 68-42	Decal, Chassis
2	532 19 68-41	Decal, Warning Eng. Sym.
3	532 15 97-37	Decal, Brake/Clutch
4	532 15 97-36	Decal, Hot Muffler
5	532 40 88-12	Decal, Eng. HP
6	532 18 04-32	Decal, DB/CE
7	532 40 03-89	Decal, Warning Sym. CE
8	532 19 43-02	Decal, V-Belt Sch.
9	532 14 08-37	Decal, Saddle Brake Parking
10	532 18 21-66	Decal, Cut Finger
11	532 41 18-93	Decal, Hood RH

KEY NO.	PART NO.	DESCRIPTION
12	532 41 18-97	Decal, Fender
13	532 41 18-96	Decal, Wheel Strg.
14	532 19 63-57	Decal, Defl. Warning
15	532 14 50-05	Decal, Caution, Battery
16	532 13 49-99	Decal, Mower Enviro
17	532 41 18-94	Decal, Hood LH
--	532 16 25-98	Decal, Drawbar
--	532 13 83-11	Decal, Handle Lft Height Adj.
--	532 41 17-69	Manual, Operator's, Euro
--	532 41 32-74	Manual, Parts

WHEELS & TIRES

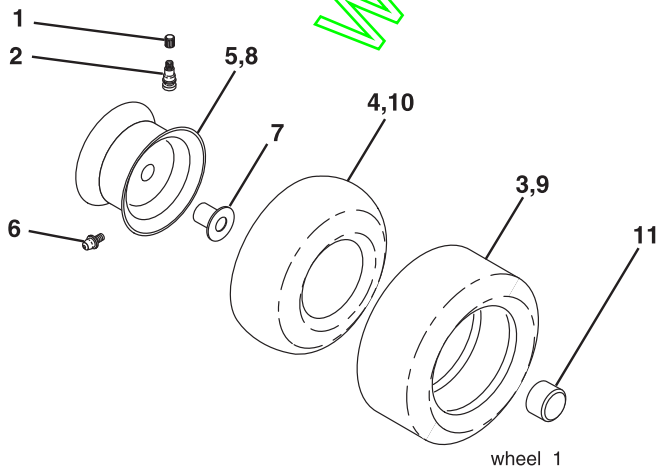

KEY NO.	PART NO.	DESCRIPTION
1	532 05 91-92	Cap, Tire Valve
2	532 06 51-39	Stem, Valve
3	532 10 62-22	Tire, Front
4	532 05 99-04	Tube, Front (Service Item Only)
5	532 13 83-36	Rim Assembly, 6" Front
6	532 12 49-57	Fitting, Grease (Front Wheel Only)
7	532 12 49-59	Bearing, Flange (Front Wheel Only)
8	532 13 83-37	Rim Assembly, 8" Rear
9	532 12 46-35	Tire, Rear
10	532 12 49-26	Tube, Rear (Service Item Only)
11	532 17 50-39	Cap, Hub Axle
--	532 14 43-34	Sealant, Tire (10 oz. Tube)

NOTE: All component dimensions given in U.S. inches
1 inch = 25.4 mm

TRACTOR -- MODEL NUMBER VENUS (96011026001), PRODUCT NO. 960 11 02-60 SCHEMATIC

SCH01

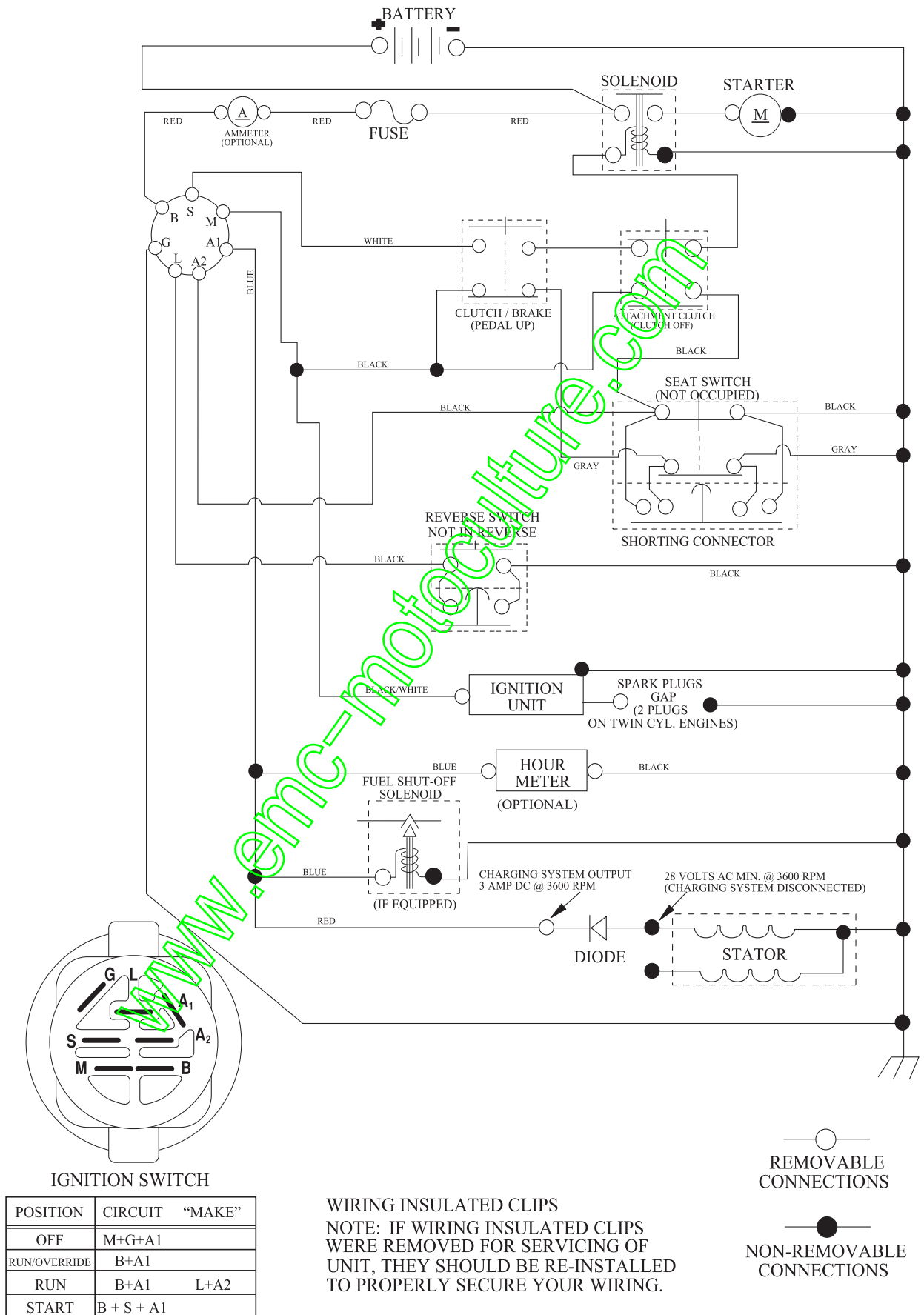

REPAIR PARTS

TRACTOR -- MODEL NUMBER VENUS (96011026001), PRODUCT NO. 960 11 02-60
ELECTRICAL

L04

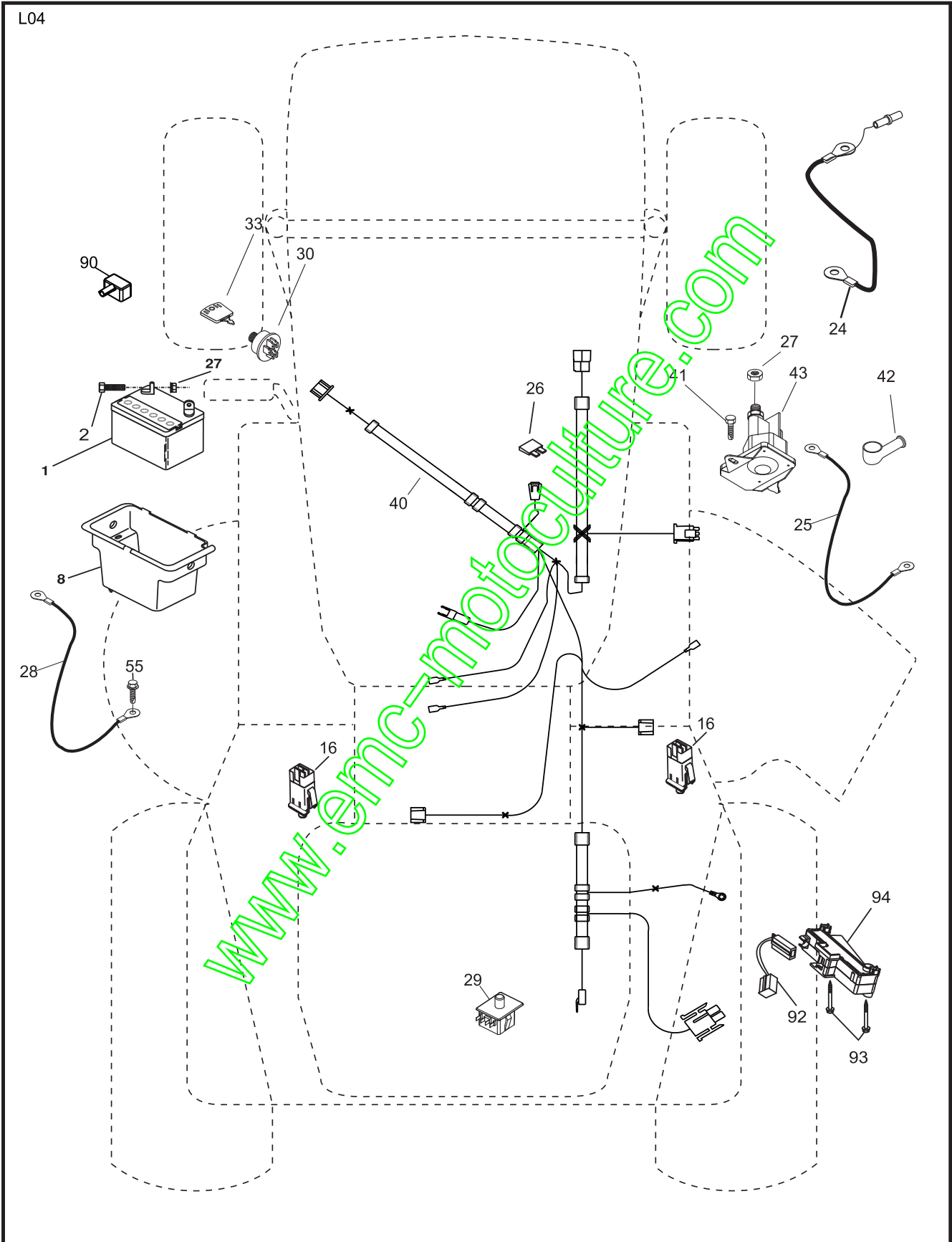

REPAIR PARTS

TRACTOR - - MODEL NUMBER VENUS (96011026001), PRODUCT NO. 960 11 02-60
ELECTRICAL

KEY NO.	PART NO.	DESCRIPTION
1	532 16 34-65	Battery 12 Volt 25 Amp
2	874 76 04-12	Bolt Hex Hd 1/4-20 unc x 3/4
8	532 17 66-89	Battery Box
16	532 17 61-38	Switch Interlock Push-In
24	532 12 47-80	Cable Battery 6 Ga. 11" Red
25	532 14 61-47	Cable Battery
26	532 17 51-58	Fuse
27	873 51 04-00	Nut Keps Hex 1/4-20 unc
28	532 12 47-73	Cable Ground 6 Ga. 12" Black
29	532 19 27-49	Switch Seat
30	532 19 33-50	Switch Ign
33	532 41 19-35	Key/Chain
40	532 19 74-28	Harness Ign
41	871 11 04-08	Bolt Blk Fin Hex 1/4-20
42	532 13 15-63	Cover Terminal Red
43	532 19 25-07	Solenoid
45	532 12 14-33	Ammeter Rectangular
55	817 00 06-12	Screw Hexwsh THDR 3/8-16 x 3/4
90	532 18 04-49	Cover Terminal Battery
92	532 19 66-15	Harness Pigtail ROS
93	532 19 25-40	Screw Plastite 10-14 x 2.0
94	532 19 18-34	Module Reverse ROS

NOTE: All component dimensions given in U.S. inches
1 inch = 25.4 mm

REPAIR PARTS

TRACTOR -- MODEL NUMBER VENUS (96011026001), PRODUCT NO. 960 11 02-60
CHASSIS AND ENCLOSURES

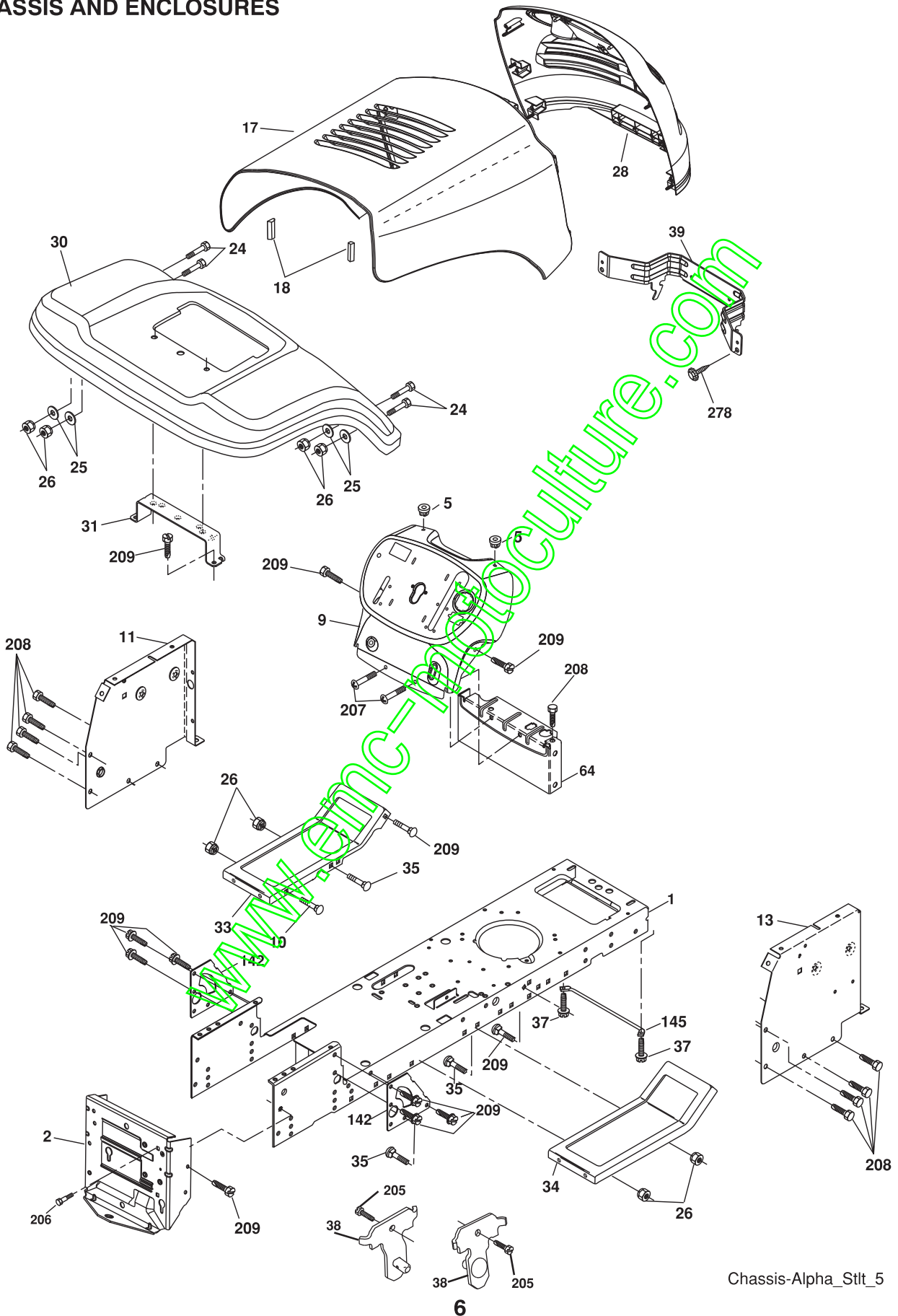

REPAIR PARTS

TRACTOR - - MODEL NUMBER VENUS (96011026001), PRODUCT NO. 960 11 02-60
CHASSIS AND ENCLOSURES

KEY NO.	PART NO.	DESCRIPTION
1	532 17 46-19	Chassis
2	532 17 65-54	Drawbar
5	532 15 52-72	Bumper, Hood/Dash
9	532 19 68-36	Dash
10	872 14 06-08	Bolt, Carriage 3/8-16 x 1
11	532 17 49-96	Panel Dash LH
13	532 18 17-19	Panel Slkscr Dash RH
17	532 41 24-35	Hood
18	532 18 49-21	Bumper Hood
24	874 78 06-16	Bolt Fin Hex 3/8-16 unc x 1 Gr. 5
25	819 13 13-12	Washer 13/32 x 13/16 x 12 Ga.
26	873 80 06-00	Nut Lock Hex w/lrs 3/8-16 unc
28	532 19 47-98	Grille
30	532 41 24-37	Fender
31	532 13 66-19	Bracket Fender Repl 109873x
33	532 41 24-46	Footrest Pnt LH
34	532 41 24-47	Footrest Pnt RH
35	872 11 06-06	Bolt Rdhg Shl Sqnk 3/8-16 x 3/4
37	817 49 05-08	Screw Thdrol 5/16-18 x 1/2 TYT
38	532 17 57-10	Bracket Asm. Pivot Mower Rear
39	532 18 75-68	Bracket Pivot
64	532 15 47-98	Dash Lower
142	532 17 57-02	Plate Reinforcement
145	532 40 91-67	Rod Pivot Chassis/Hood
205	817 49 06-08	Screw Thdrol 3/8-16 x 1/2
206	532 17 01-65	Bolt Shoulder 5/16-18
207	817 67 05-08	Screw Thdrol 5/16-18 x 1/2
208	817 67 06-08	Screw Thdrol 3/8-16 x 1/2
209	817 00 06-12	Screw Hex Wsh Thdrol 3/8-16 x 3/4
278	532 19 16-11	Screw 10 x 3/4 Single Lead-Hex
--	532 19 39-35	Plug Switch Light

NOTE: All component dimensions given in U.S. inches
1 inch = 25.4 mm.

REPAIR PARTS

TRACTOR - - MODEL NUMBER VENUS (96011026001), PRODUCT NO. 960 11 02-60
DRIVE

KEY NO.	PART NO.	DESCRIPTION	KEY NO.	PART NO.	DESCRIPTION
1	---	Transaxle DANA D6800-5	65	810 04 07-00	Washer Lock Hvy Hlcl Spr 7/16
2	532 14 66-82	Spring Return Brake T/A Zinc	66	532 15 47-78	Keeper Belt Engine Foolproof
3	532 12 36-66	Pulley Transaxle 18" Tires	69	532 14 24-32	Screw Hex 1/4-1/2 unc
4	812 00 00-28	Ring Retainer #5100-62	70	532 13 46-83	Guide Belt Mower Drive RH
5	532 12 15-20	Strap Torque 30 Degrees	75	532 12 17-49	Washer 25/32 x 1 1/4 x 16 Ga.
6	817 06 05-12	Screw Thdrol 5/16-18 x 3/4	76	812 00 00-01	E-ring #5133-75
8	532 19 27-06	Rod Shift Fender Adjust Lt	77	532 12 35-83	Key Square 2 0 x 1845/1865
10	876 02 04-16	Pin Cotter 1/8 x 1 Cad	78	532 12 17-48	Washer 25/32 x 1-5/8 x 16 Ga.
11	532 10 57-01	Washer Plate Shf 388 Sq Hole	79	532 12 50-96	Key Woodruff #9 3/16 x 3/4
13	874 55 04-12	Bolt 1/4-28 unF Gr. 8 w/Patch	80	532 13 14-88	Arm Shift
14	810 04 04-00	Washer Lock Hvy Helical	81	532 16 55-94	Shaft Asm Cross 18" T
15	874 49 05-44	Bolt Hex 5/16-18 Gr. 5	82	532 16 57-11	Spring Torsion T/A
16	873 80 05-00	Nut Lock Hex w/lns 5/16-18	83	819 17 12-16	Washer 17/32 x 3/4 x 16 Ga.
18	874 78 06-16	Bolt, Fin Hex 3/8-16 unc x 1 Gr. 5	84	532 16 62-29	Link Transaxle
19	873 80 06-00	Nut Lock 3/8-16 unc	85	532 15 03-60	Nut Lock Center 1/4-28 FNTHD
21	532 10 69-33	Knob	89	532 19 58-61	Console Shift STLT
22	532 13 08-04	Rod Brake Blk Zinc 26 840	96	532 12 47-88	Retainer Spring 1"
24	873 35 06-00	Nut Hex Jam 3/8-16 unc	112	819 09 12-10	Washer 9/32 x 3/4 x 10 Ga.
25	532 10 68-88	Spring Rod Brake 2 00 Zinc	113	532 12 72-85	Strap Torque LT
26	819 13 13-16	Washer 13/32 x 13/16 x 16 Ga.	116	872 14 06-08	Bolt Rdhd Sq Neck 3/8-16 x 1.0
27	876 02 04-12	Pin Cotter 1/8 x 3/4 Cad	120	873 90 06-00	Nut Lock Flg. 3/8-16 unc
28	532 17 57-65	Rod Brake Parking LT/YT	150	532 17 54-56	Spacer
29	532 07 16-73	Cap Brake Parking Black	151	819 13 32-10	Washer 13/32 x 2 x 10 Ga.
30	532 17 49-73	Bracket Mtg Transaxle	156	532 16 60-02	Washer Srrted 5/16 ID x 1.125
32	874 76 05-12	Bolt Hex Hd 5/16-18 unc x 3/4	158	532 16 55-89	Bracket Shift Mount
34	532 17 55-78	Shaft Asm Pedal Foot	159	532 18 39-00	Hub Shift
35	532 12 01-83	Bearing Nylon Blk 629 Id	161	872 14 04-06	Bolt Rdhd Sqnk 1/4-20 x 3/4 Gr. 5
36	819 21 16-16	Washer 21/32 x 1 x 16 Ga.	162	873 68 04-00	Nut Crownlock 1/4-20 unc
37	532 12 49-63	Pin Roll 3/16 x 1"	163	874 78 04-16	Bolt Hex Fin 1/4-20 unc x 1 Gr. 5
38	532 17 91-14	Pulley Idler Composite	165	532 16 56-23	Bracket Pivot Lever
39	872 11 06-22	Bolt Fin Hex 3/8-16 unc x 2-3/4 Gr. 5	166	817 49 05-10	Screw 5/16-18 x 5/8
41	532 17 55-56	Keeper Belt Idler Flat	168	532 16 54-92	Bolt Shoulder 5/16-18 x .561
47	532 12 77-83	Pulley Idler V Groove Plastic	169	532 16 55-80	Plate Fastening Lt
48	532 15 44-07	Bellcrank Clutch Grnd Driv	170	532 18 74-14	Keeper, Belt T/A
49	532 12 32-05	Retainer Belt Style Spring	197	532 16 96-13	Nyliner Snap-In
50	872 11 06-12	Bolt 3/8-16 x 1-1/2 Gr. 5	198	532 16 95-93	Washer Nyl
51	873 68 06-00	Nut Crownlock 3/8-16 unc	202	872 11 06-14	Bolt Carr. SH 3/8-16 x 1-3/4 Gr. 5
52	873 68 05-00	Nut Crownlock 5/16-18 unc	212	532 14 52-12	Nut, Hex Flange Lock
53	532 19 96-52	Link Clutch	263	817 00 06-12	Screw 3/8-16 x 3/4
55	532 10 57-09	Spring Return Clutch 6 75	268	532 18 24-02	Guard Muffler
56	817 06 06-20	Screw 3/8-16 x 3/4	275	819 13 16-14	Washer 13/32 x 1 x 14 Ga.
57	532 40 16-03	V-Belt Ground Drive 95 68			
59	532 16 96-91	Keeper Belt Span Ctr			
61	817 12 06-14	Screw 3/8-16 x .875			
62	532 12 48-72	Cover Pedal Round			
63	532 17 54-10	Engine Pulley			
64	532 17 39-37	Bolt Hex			

NOTE: All component dimensions given in U.S. inches
1 inch = 25.4 mm.

REPAIR PARTS

TRACTOR -- MODEL NUMBER VENUS (96011026001), PRODUCT NO. 960 11 02-60
STEERING

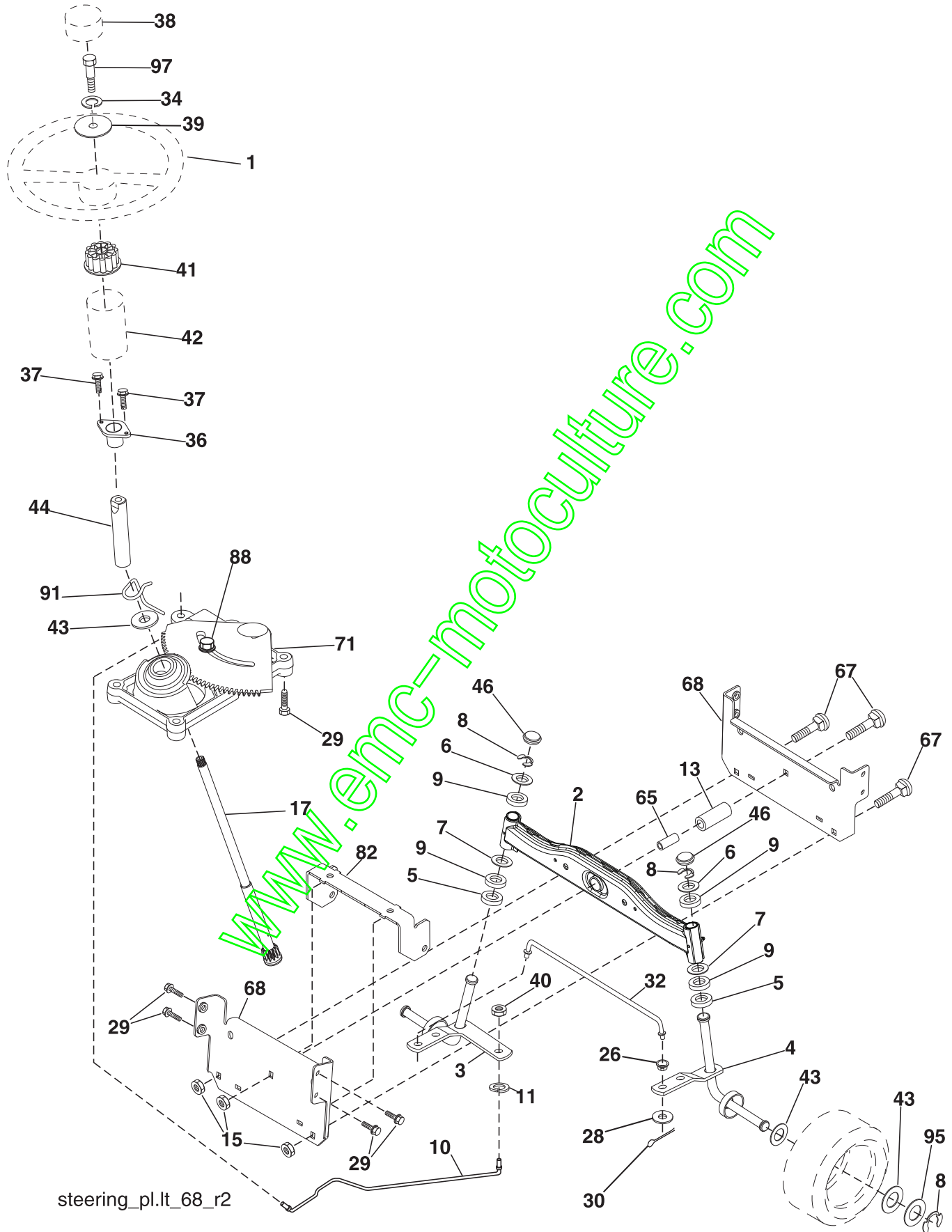

steering_pl.lt_68_r2

REPAIR PARTS

TRACTOR -- MODEL NUMBER VENUS (96011026001), PRODUCT NO. 960 11 02-60
STEERING

KEY NO.	PART NO.	DESCRIPTION
1	532 18 67-80	Wheel Steering
2	532 19 56-73	Axle Asm
3	532 16 98-40	Spindle Asm LH
4	532 16 98-39	Spindle Asm RH
5	532 12 49-31	Bearing Race Thrust Harden
6	532 12 17-48	Washer 25/32 x 1-5/8 x 16 Ga.
7	819 27 20-16	Washer 27/32 x 1-1/4 x 16 Ga.
8	812 00 00-29	Ring Clip #t5304-75
9	532 12 49-37	Bearing Col Strg Blk
10	532 17 51-21	Link Drag
11	810 04 06-00	Washer Lock Hvy Hlcl Spr 3/8
13	532 13 65-18	Spacer Bearing Axle Front
15	532 14 52-12	Hexflange Lock
17	532 19 07-53	Shaft Asm Strg
26	532 12 68-47	Bushing Link Drag Blk LR
28	819 13 14-16	Washer 13/32 x 7/8 x 16 Ga.
29	817 00 06-12	Screw 3/8-16 x 3/4
30	876 02 04-12	Pin Cotter 1/8 x 3/4 Cad
32	532 19 27-57	Rod Tie
34	810 04 05-00	Washer Lock Hvy Hlcl Spr. 5/16
36	532 15 50-99	Bushing Strg 5/8 Id Dash
37	532 15 29-27	Screw
38	532 19 29-16	Cap Wheel Steering
39	819 11 38-12	Washer 11/32 ID x 2-3/8OD 12 Ga.
40	873 54 06-00	Nut Crownlock 3/8-24
41	532 18 67-37	Adapter Wheel Strg
42	532 16 96-33	Boot Steering
43	532 12 17-49	Washer 25/32 x 1 1/4 x 16 Ga.
44	532 19 07-52	Extension Steering
46	532 12 12-32	Cap Spindle Fr Top Blk
65	532 41 47-36	Spacer Brace Axle
67	872 17 06-18	Bolt RdHd Sqnk 3/8-16 x 2-1/4
68	532 16 98-27	Brace Axle
71	532 17 51-46	Steering Asm
82	532 19 99-78	Bracket Susp Chassis Front
88	532 17 51-18	Bolt Shoulder 7/16-20
91	532 17 55-53	Clip Steering
95	532 18 89-67	Washer Hardened
97	874 78 05-64	Bolt 5/16-18 unc x 4" L Gr. 5

NOTE: All component dimensions given in U.S. inches
1 inch = 25.4 mm.

REPAIR PARTS

TRACTOR -- MODEL NUMBER VENUS (96011026001), PRODUCT NO. 960 11 02-60
ENGINE

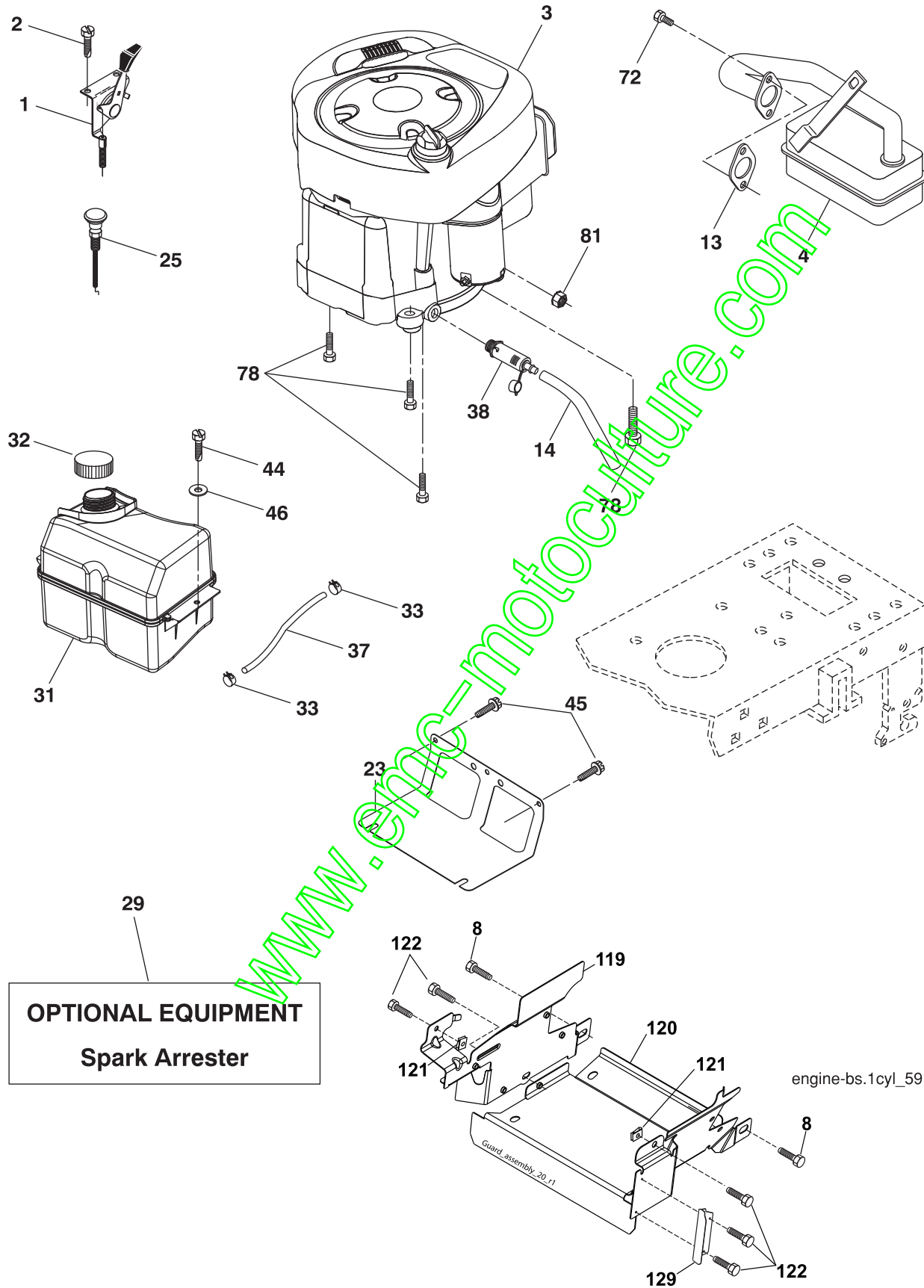

engine-bs.1cyl_59

REPAIR PARTS

TRACTOR - - MODEL NUMBER VENUS (96011026001), PRODUCT NO. 960 11 02-60 ENGINE

KEY NO.	PART NO.	DESCRIPTION
1	532 17 05-51	Control Throttle/Choke
2	817 72 04-08	Screw Hex Thd Cut 1/4-20 x 5/8 T
3	---	Engine Briggs Model 217807
4	532 17 97-58	Muffler Exhaust
8	532 17 18-77	Bolt 5/16-18 unc x 3/4
13	532 16 52-91	Gasket
14	532 14 84-56	Tube Drain Oil Easy
23	532 16 98-37	Shield Browning/Debris Guard
25	532 19 06-95	Control Choke
29	532 13 71-80	Arrester Spark
31	532 40 75-16	Tank Fuel
32	532 19 77-25	Cap Asm Fuel Top
33	532 12 34-87	Clamp Hose Blk
37	532 13 70-40	Line Fuel 20"
38	532 18 16-54	Plug Drain Oil Easy
44	817 67 04-12	Screw Hexwsh Thdrol 3/8-16 x 3/4
45	817 00 06-12	Screw 3/8-16 x 3/4
46	819 09 14-16	Washer 9/32 x 7/8 x 16 Ga.
72	532 19 23-34	Screw Socket HD 5/16-18 x .75
78	817 06 06-20	Screw 3/8-16 x 1-1/4
81	873 51 04-00	Nut Keys Hex 1/4-20 unc
119	532 19 79-49	Guard Pulley LH
120	532 19 79-48	Guard Pulley RH
121	532 19 66-88	Clip Threaded
122	532 13 77-29	Screw Thdrol. 1/4-20 x 5/6
129	532 40 06-28	Guard Pulley Eng. Adapter

NOTE: All component dimensions given in U.S. inches
1 inch = 25.4 mm

Engine Power Rating Information

The gross power rating for individual gas engine models is labeled in accordance with SAE (Society of Automotive Engineers) code J11940 (Small Engine Power & Torque Rating Procedure), and rating performance has been obtained and corrected in accordance with SAE J1995 (Revision 2002-5). Actual gross engine power will be lower and is affected by, among other things, ambient operating conditions and engine-to-engine variability. Given both the wide array of products on which engines are placed and the variety of environmental issues applicable to operating the equipment, the gas engine will not develop the rated gross power when used in a given piece of power equipment (actual "on-site" or net horsepower). This difference is due to a variety of factors including, but not limited to, accessories (air cleaner, exhaust, charging, cooling, carburetor, fuel pump, etc.), application limitations, ambient operating conditions (temperature, humidity, altitude), and engine-to-engine variability. Due to manufacturing and capacity limitations, Briggs & Stratton may substitute an engine of higher rated power for this Series engine.

REPAIR PARTS

TRACTOR -- MODEL NUMBER VENUS (96011026001), PRODUCT NO. 960 11 02-60
SEAT

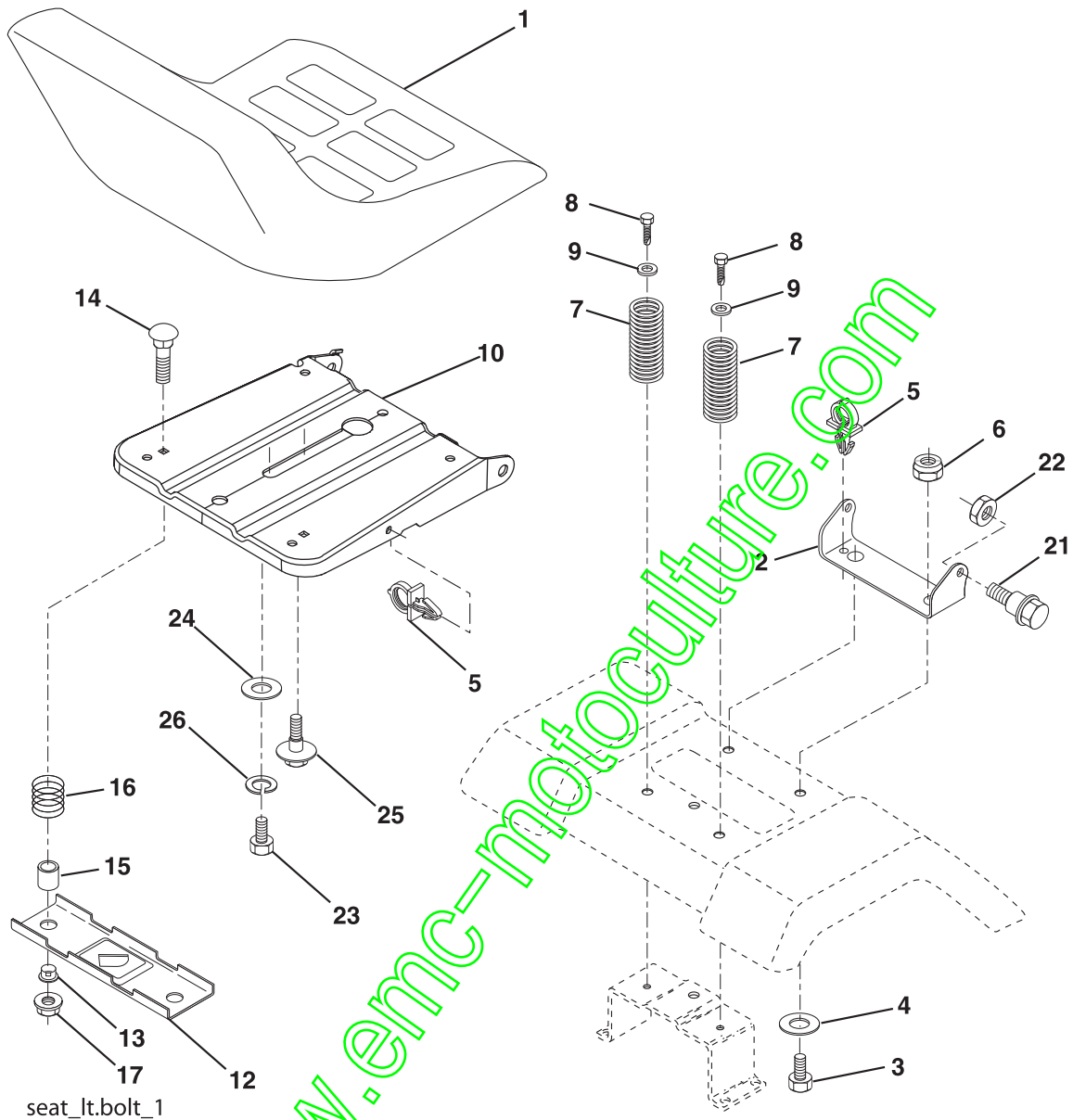

KEY NO.	PART NO.	DESCRIPTION
1	532 40 10-42	Seat
2	532 14 05-51	Bracket Seat Pivot
3	871 11 06-16	Bolt Hex 3/8-16 x 1
4	819 13 16-10	Washer 13/32 x 1 x 10 Ga.
5	532 14 50-06	Clip Push-In Hinged
6	873 80 06-00	Nut Lock Hex w/Ins 3/8-16
7	532 12 41-81	Spring Seat Cprsn 2 250 Blk Zi
8	817 00 06-16	Screw 3/8-16 x 1.5
9	819 13 16-14	Washer 13/32 x 1 x 14 Ga.
10	532 19 55-30	Pan Pnt Seat (Blk)
12	532 17 46-48	Bracket Pnt Mounting Switch
13	532 12 12-48	Bushing Snap Blk Nyl

KEY NO.	PART NO.	DESCRIPTION
14	872 05 04-12	Bolt Rdhd Sht Nk 1/4-20 x 1-1/2
15	532 13 43-00	Spacer Split .28 x .96
16	532 12 12-50	Spring Cprsn
17	532 12 39-76	Nut Lock 1/4 Lge Flg
21	532 17 18-52	Bolt Shoulder 5/16-18 unc-2A
22	873 80 05-00	Nut Lock Hex w/Ins 5/16-18
23	871 11 08-14	Bolt Hex Black
24	819 17 19-12	Washer 17/32 x 1-3/16 x 12 Ga.
25	532 12 70-18	Bolt Shoulder 5/16-18 x .62
26	810 04 08-00	Washer Lock Hvy Hlcl Spr 1/2

NOTE: All component dimensions given in U.S. inches
1 inch = 25.4 mm

REPAIR PARTS

TRACTOR - - MODEL NUMBER VENUS (96011026001), PRODUCT NO. 960 11 02-60
MOWER LIFT

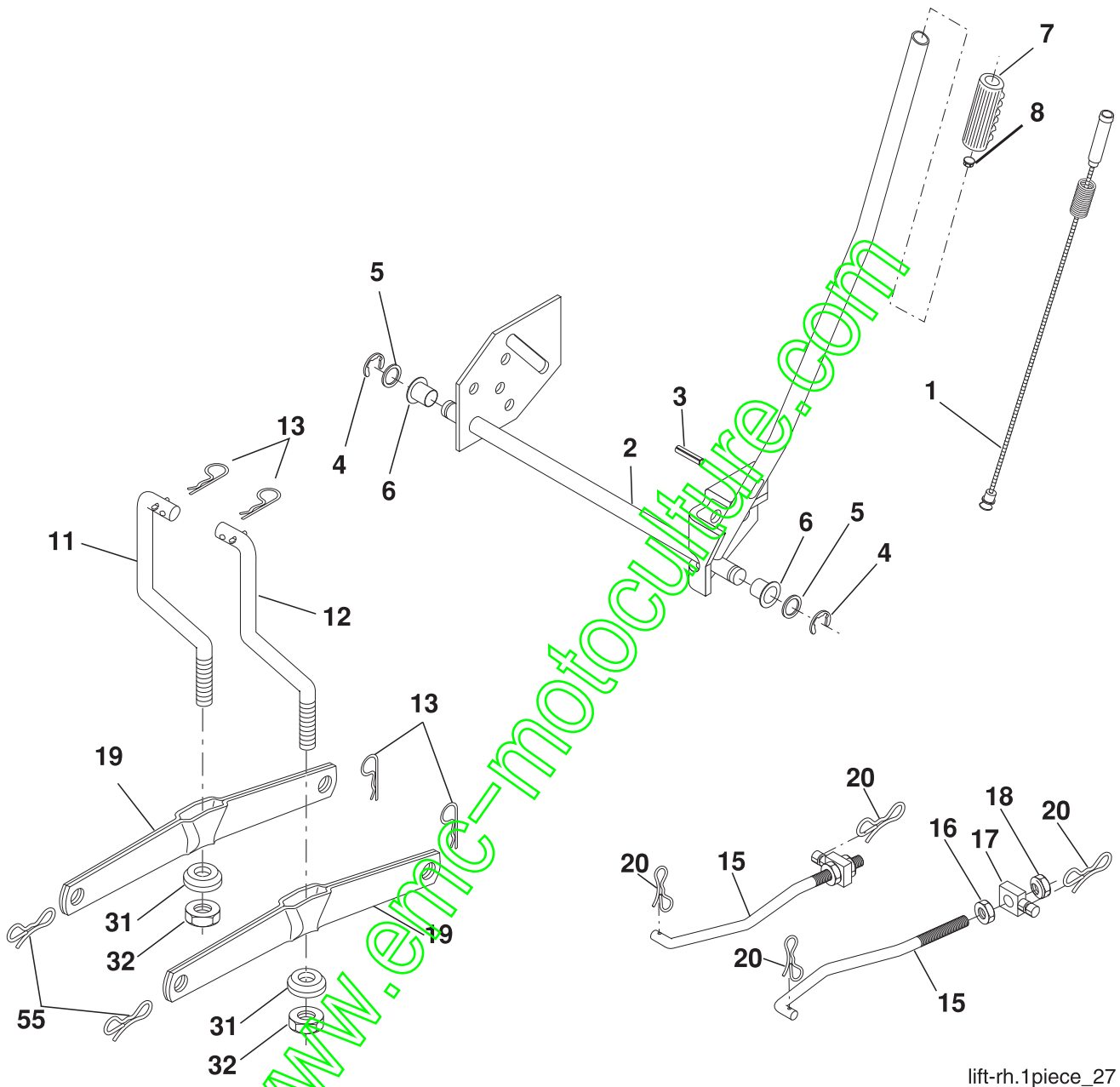

lift-rh.1piece_27

KEY NO.	PART NO.	DESCRIPTION
1	532 15 94-60	Wire Asm Inner/Sprg w/Plunger
2	532 15 94-71	Shaft Asm Lift RH
3	532 10 57-67	Pin Groove
4	812 00 00-02	E Ring #5133-62
5	819 21 16-21	Washer 21/32 x 1 x 21 Ga.
6	532 12 01-83	Bearing Nylon Blk 629 Id
7	532 10 94-13	Grip Handle Bicycle Matte Blk
8	532 12 45-26	Button Plunger Black
11	532 13 98-65	Link Lift LH Fixed Length
12	532 13 98-66	Link Lift RH Fixed Length
13	532 12 46-70	Retainer Spring

KEY NO.	PART NO.	DESCRIPTION
15	532 17 32-88	Link Front
16	873 35 08-00	Nut Jam Hex 1/2-13 unc
17	532 17 56-89	Trunnion
18	873 80 08-00	Nut Lock w/Wsh 1/2-13 unc
19	532 13 98-68	Arm Suspension Rear
20	532 19 42-09	Pin Cotter 7/16 Bow Tie Lock
31	532 16 98-65	Bearing Pvt Lift
32	873 54 06-00	Nut Crownlock 3/8-24
55	532 19 42 08	Pin Cotter 5/16 Bowtie Lock

NOTE: All component dimensions given in U.S. inches
1 inch = 25.4 mm

REPAIR PARTS

TRACTOR -- MODEL NUMBER VENUS (96011026001), PRODUCT NO. 960 11 02-60
MOWER DECK

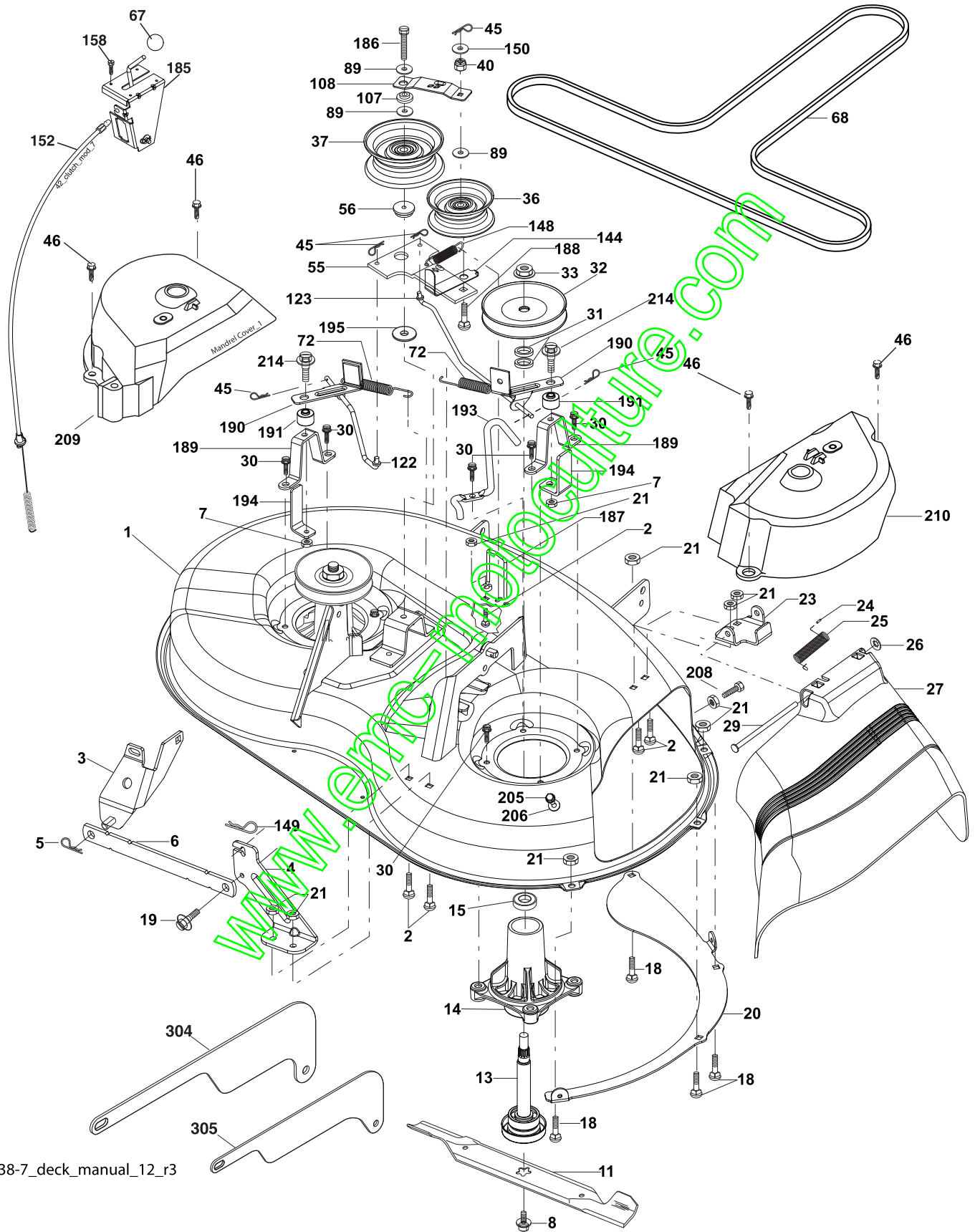

REPAIR PARTS

TRACTOR - - MODEL NUMBER VENUS (96011026001), PRODUCT NO. 960 11 02-60
MOWER DECK

KEY NO.	PART NO.	DESCRIPTION	KEY NO.	PART NO.	DESCRIPTION
1	532 19 25-56	Mower Housing Assembly	108	532 13 35-03	Stiffener, Idler Arm
2	872 14 05-06	Bolt Carriage 5/16-18 x 3/4	122	532 41 01-89	Rod, Brake LH Link
3	532 13 80-17	Bracket Asm Fr. Sway Bar	123	532 41 01-90	Rod, Brake RH Link
4	532 19 25-68	Bracket Deck Sway Bar 38"/42"	144	532 19 34-14	Keeper Belt Idler Tension
5	532 12 46-70	Retainer Spring	148	532 16 90-22	Spring Return Idler
6	532 17 80-24	Bar Sway Deck	149	532 16 58-98	Retainer, Spring Yellow
7	873 80 05-00	Nut Lock Hex w/Ins 5/16-18 unc	150	819 09 12-10	Washer 9/32 x 3/4 x 10 Ga.
8	532 19 30-03	Bolt 3/8-24 x 1.25 Gr. 8	152	532 19 32-35	Clutch Cable 38"/46"
11	532 19 39-57	Blade Mower	158	817 72 04-08	Screw Hex Thd Cut 1/4-20 x 1/2
13	532 19 28-72	Shaft Assembly, Mandrel, Vented	185	532 18 82-34	Head Asm Cable Clutch
14	532 18 72-81	Housing, Mandrel, Vented	186	817 49 06-44	Screw Hex Wsh Thdrol 3/8-16 x 2-3/4
15	532 11 04-85	Bearing, Ball, Mandrel	187	532 19 34-12	Keeper Belt
18	872 14 05-05	Bolt Rdhd Sqnk 5/16-18 x 5/8	188	532 16 58-91	Bolt Carriage Idler
19	532 13 28-27	Bolt, Shoulder	189	532 19 25-59	Stand, Brake
20	532 40 00-95	Baffle Vortex Front	190	532 19 25-60	Arm, Brake
21	873 68 05-00	Nut	191	532 19 25-61	Spacer, Brake
23	532 19 25-57	Bracket, Mower Deflector	193	532 19 34-13	Keeper Belt RH Mandrel
24	532 10 53-04	Cap, Sleeve	194	532 19 41-05	Guard Brake
25	532 19 70-26	Spring, Torsion, Deflector	195	819 13 32-10	Washer
26	532 11 04-52	Nut, Push	205	817 49 04-16	Screw 1/4-20 x 1.00
27	532 40 16-18	Shield, Deflector	206	819 09 14-16	Washer 9/32 x 7/8 x 16
29	532 13 14-91	Rod, Hinge	208	817 67 06-08	Screw Thdrol 3/8-16 x 1/2
30	532 17 39-84	Screw Thdrol.	209	532 40 92-56	Cover Mandrel LH
31	532 18 76-90	Washer, Spacer	210	532 40 92-57	Cover Mandrel RH
32	532 15 35-32	Pulley, Mandrel	214	532 19 37-82	Bolt/Washer Asm 5/16-18
33	532 40 02-34	Nut, Toplock	304	532 41 05-20	Shield Side LH
36	532 13 14-94	Pulley, Idler, Flat	305	532 41 05-21	Shield Side RH
37	532 19 31-98	Pulley Idler Flat	--	532 19 25-58	Brake Assembly (Includes Stand, Arm and Guard Components)
40	873 68 06-00	Nut, Crownlock 3/8-16 unc	--	532 19 28-70	Mandrel Assembly (Includes housing, shaft assembly, and bearing only - pulley/nut/washer and blade bolt/washers not included)
45	532 12 47-88	Retainer	--	532 19 36-46	Replacement Mower, Complete
46	532 13 77-29	Screw Thdrol 1/4-20 x 5/8			
55	532 13 38-40	Idler Arm Assembly			
56	532 16 57-23	Spacer, Retainer			
67	532 10 69-32	Knob			
68	532 19 32-14	V-Belt			
72	532 19 32-16	Spring Brake Return			
89	819 13 13-11	Washer 13/32 x 13/16 x 11 Ga.			
107	532 13 35-02	Spacer Retainer			

NOTE: All component dimensions given in U.S. inches
1 inch = 25.4 mm

SERVICE NOTES

www.emc-motoculture.com

SERVICE NOTES

www.emc-motoculture.com

www.emc-motoculture.com

www.emc-motoculture.com