



SPARE PARTS LIST

CHAIN SAWS: ELECTRIC

1400 ELECTRIC, 1998-10

www.emc-moculture.com

G

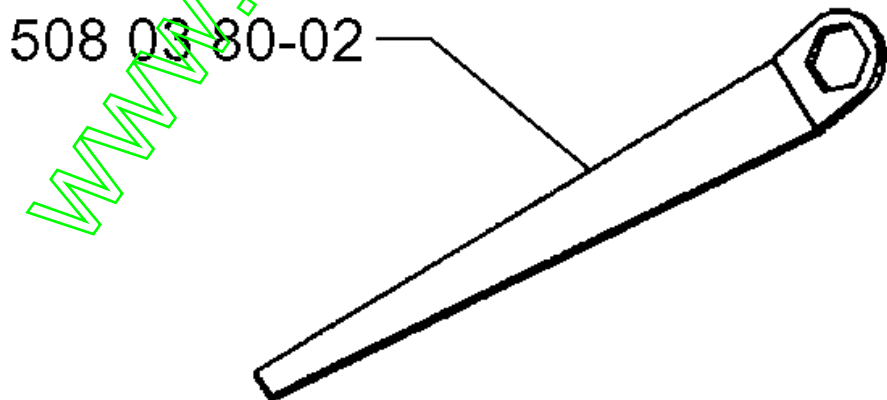
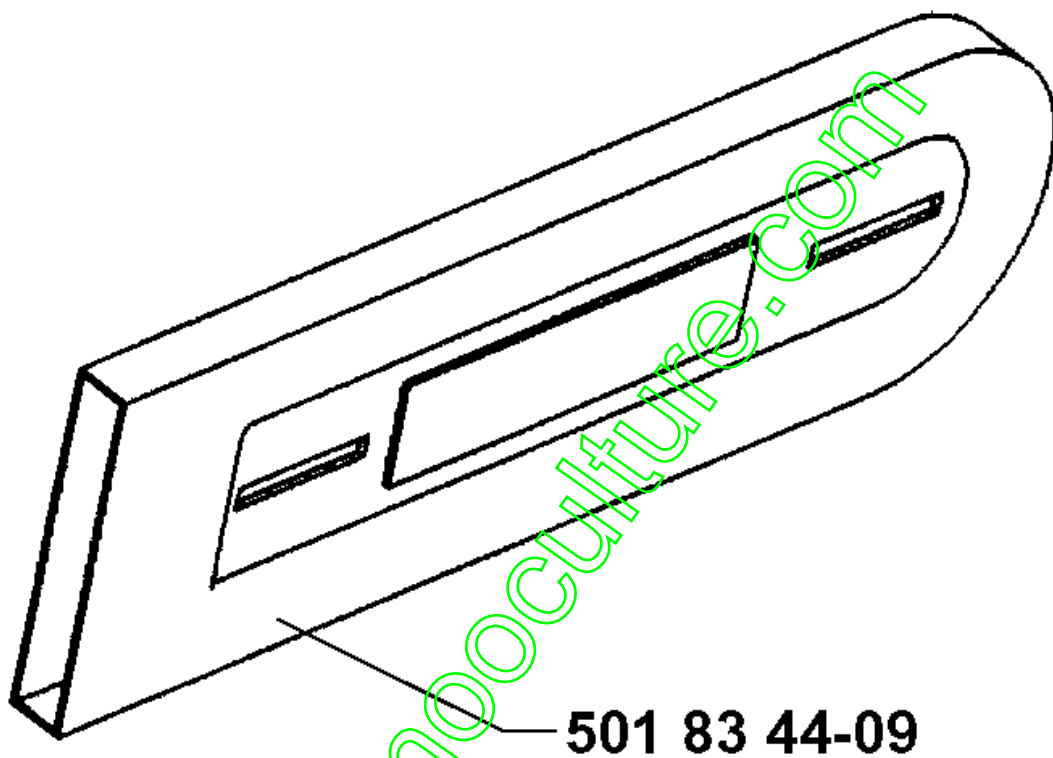

www.emc-mooculture.com

Numéro de Pièce	Description	Remarque	QTÉ Kit équipement
501 83 44-09	BAR COVER		1
508 03 80-02	CLE ALLEN		1

www.emc-mooculture.com

A

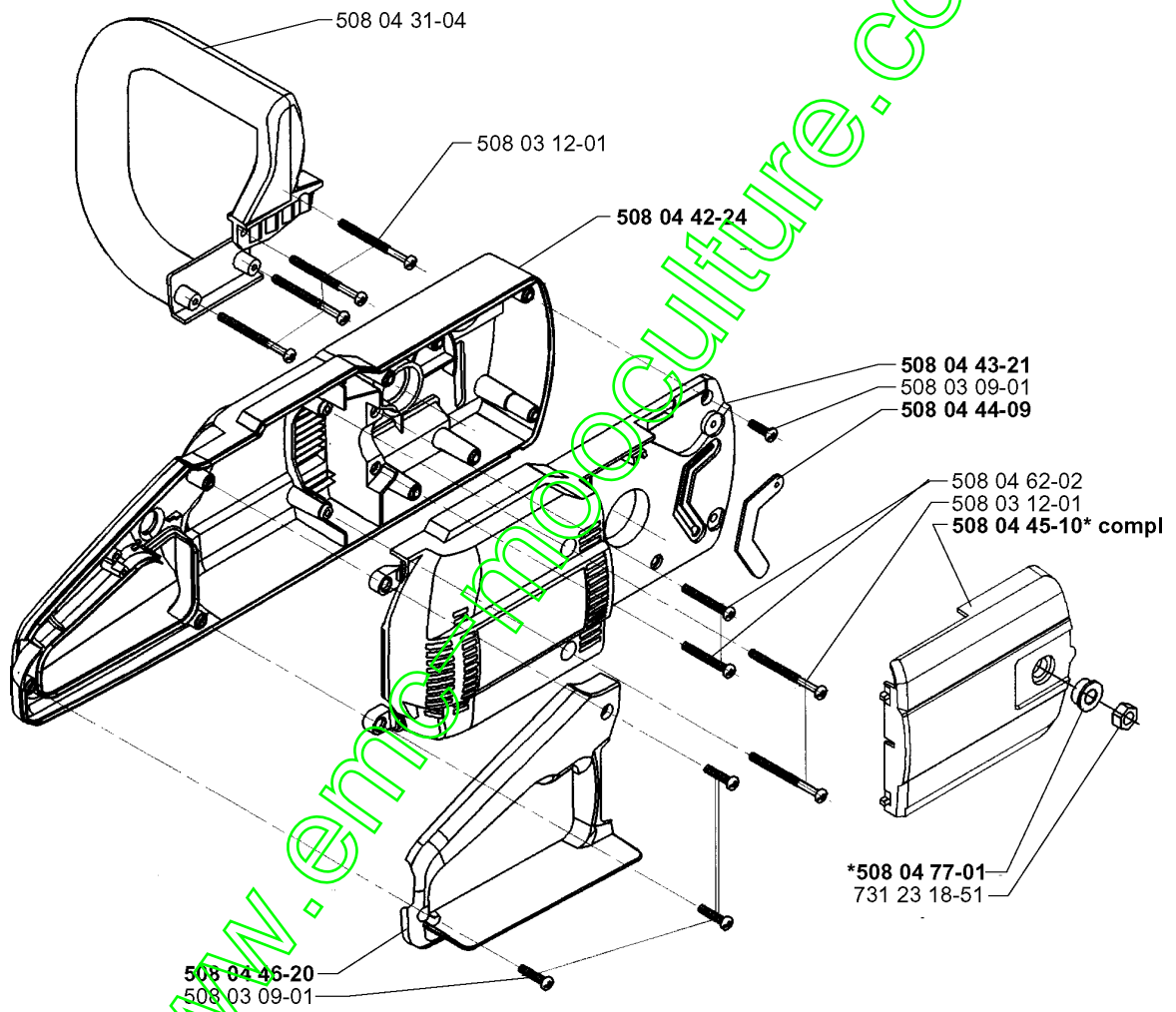

Numéro de Pièce	Description	Remarque	QTÉ Kit équipement
508 03 09-01	VIS		1
508 03 09-01	VIS		1
508 03 12-01	VIS		1
508 03 12-01	VIS		1
508 04 31-04	TUBULAR HANDLE		1
508 04 42-24	CARTER		1
508 04 43-21	CARTER		1
508 04 44-09	JOINT		1
508 04 45-10	CARTER		1
508 04 46-20	POIGNÉE		1
508 04 62-02	VIS		1
508 04 77-01	RONDELLE D'ESPACEMENT		1
731 23 18-51	ECROU HEXAGONAL		1

www.emc-mooculture.com

C



508 03 86-08
(1400)
508 03 86-09
(1600)

www.emc-motoculture.com

Numéro de Pièce	Description	Remarque	QTÉ Kit équipement
508 03 86-08	DECAL	1400	1
508 03 86-09	DECAL	1600	1

www.emc-mooculture.com

B

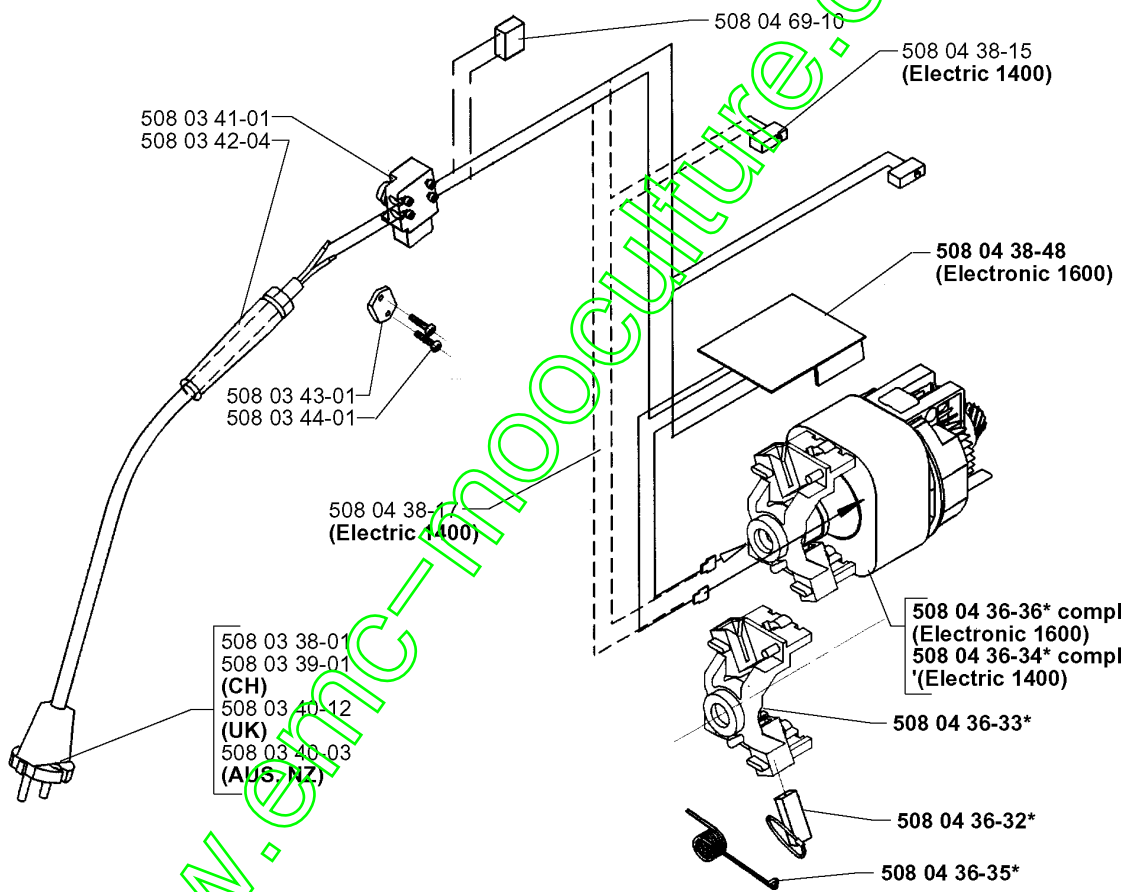

Numéro de Pièce	Description	Remarque	QTÉ Kit équipement
508 03 38-01	CABLE W/ PLUG		1
508 03 39-01	CABLE W/ PLUG	CH	1
508 03 40-03	CABLE W/ PLUG	AUS, NZ	1
508 03 40-12	CABLE W/PLUG	UK	1
508 03 41-01	INTERRUPTEUR		1
508 03 42-04	DOUILLE		1
508 03 43-01	COLLIER DE CABLE		1
508 03 44-01	VIS		1
508 04 36-32	BROSSE		1
508 04 36-33	BMC BRACKET		1
508 04 36-34	MOTEUR	ELECTRIC 1400	1
508 04 36-35	RESSORT		1
508 04 36-36	MOTEUR	ELECTRONIC 1600	1
508 04 38-15	MICRO INTERRUPTEUR	ELECTRIC 1400	1
508 04 38-17	LEAD	ELECTRIC 1400	1
508 04 38-48	PRINTED CIRCUIT CARD	ELECTRONIC 1600	1
508 04 69-10	CONDENSATEUR		1

www.emc-mooculture.com

E

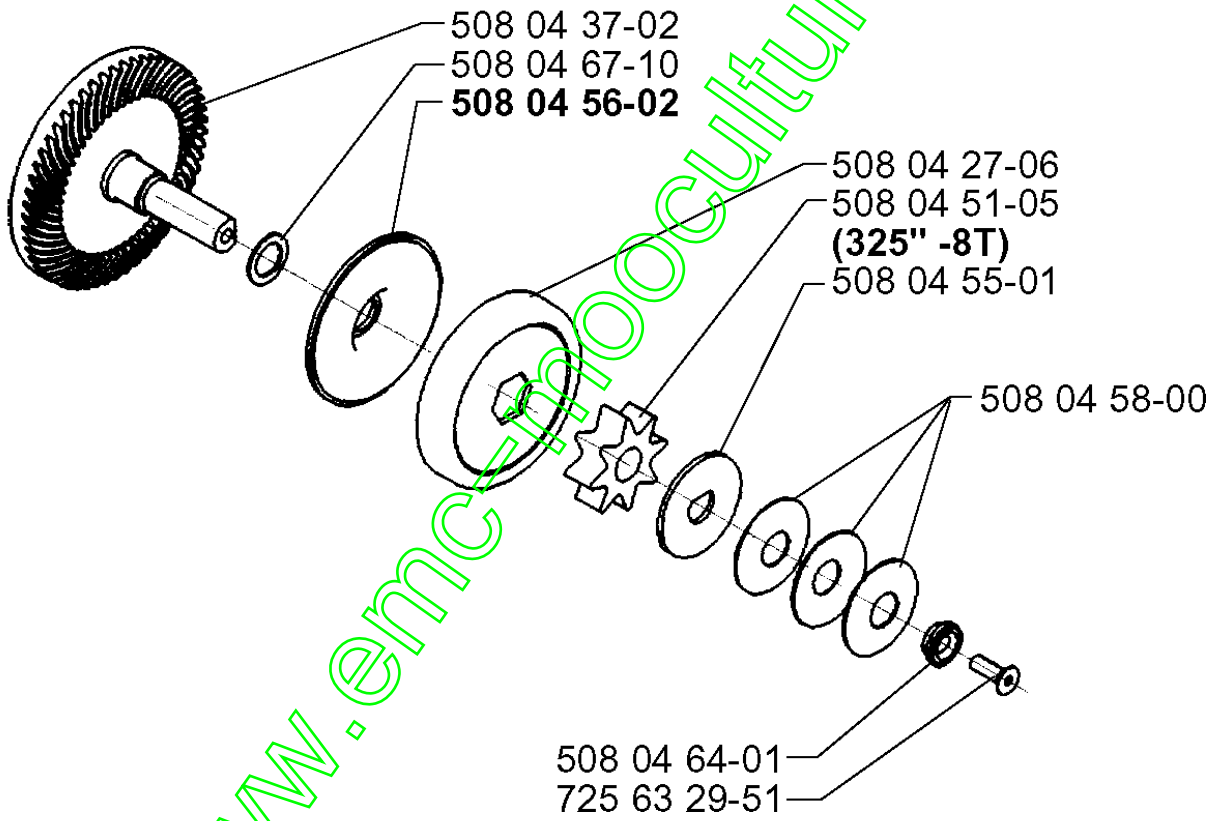

EMBAYAGE

1400 ELECTRIC, 1998-10

Numéro de Pièce	Description	Remarque	QTÉ Kit équipement
508 04 27-06	TAMBOUR D'EMBAYAGE		1
508 04 37-02	ROUE D'ENGRENAGE		1
508 04 51-05	ENGRENAGE	325 -8T	1
508 04 55-01	PLAQUE		1
508 04 56-02	PLAQUE		1
508 04 58-00	RONDELLE		1
508 04 64-01	CARRIER		1
508 04 67-10	RONDELLE		1
725 63 29-51	VIS IHCSFM		1

www.emc-mooculture.com

D

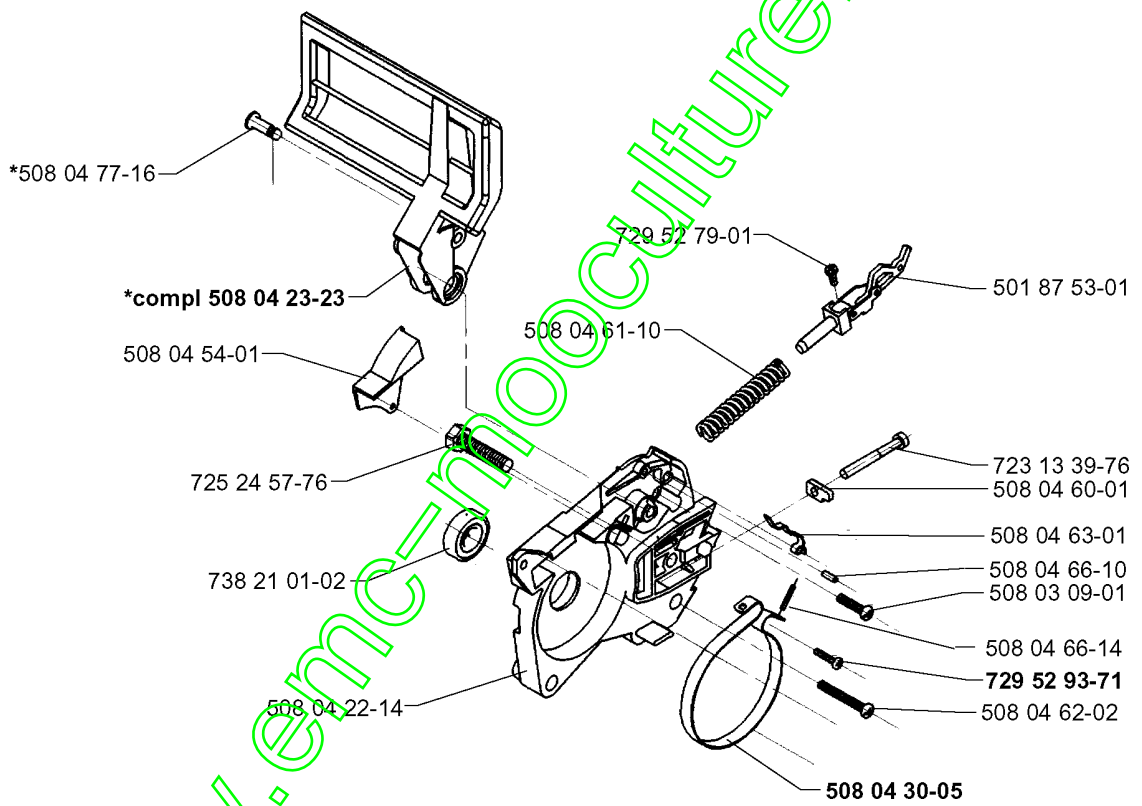

Numéro de Pièce	Description	Remarque	QTÉ Kit équipement
501 87 53-01	GENOUILLEÈRE COMPLÈTE		1
508 03 09-01	VIS		1
508 04 22-14	SUPPORT		1
508 04 23-23	OEILLET		1
508 04 30-05	BANDE DE FREIN		1
508 04 54-01	ISOLATEUR		1
508 04 60-01	DÉ DE TENSION DE CHAÎNE		1
508 04 61-10	RESSORT		1
508 04 62-02	VIS		1
508 04 63-01	RESSORT		1
508 04 66-10	STYLO		1
508 04 66-14	VIS		1
508 04 77-16	PIN RETAINING SCREW		1
723 13 39-76	VIS SLCHM		1
725 24 57-76	VIS EHHM		1
729 52 79-01	VIS CRPANT		1
729 52 93-71	VIS CRPANT		1
738 21 01-02	ROULEMENT À BILLES		1

www.emc-mooculture.com

F

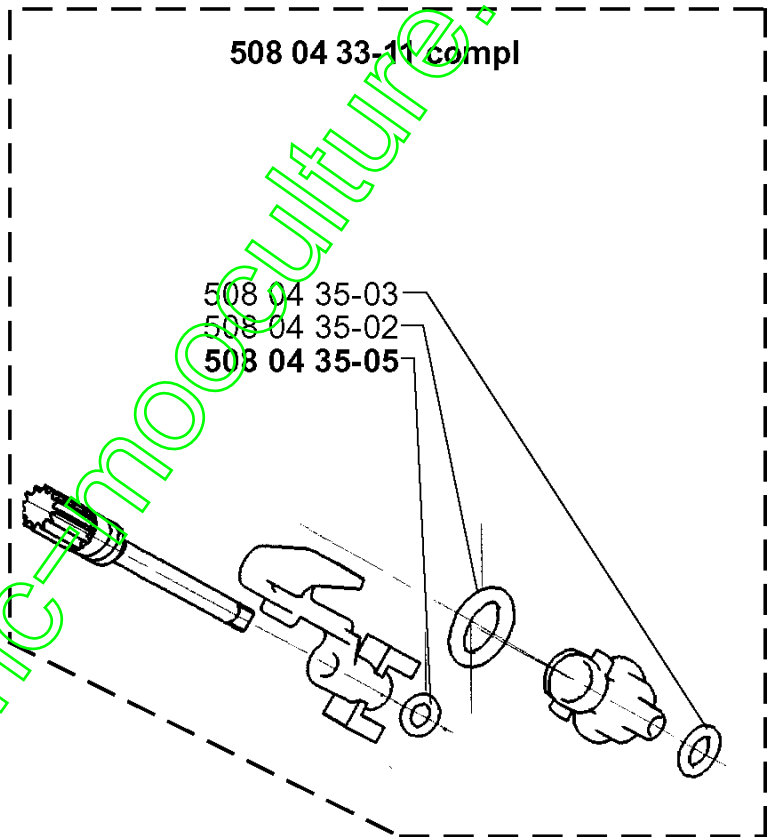
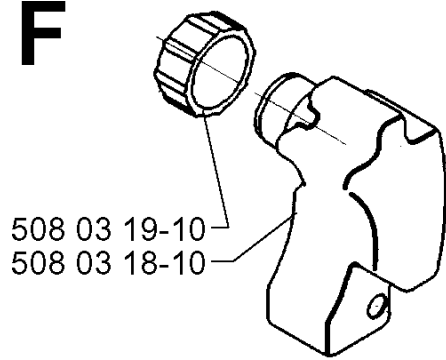

www.emc-motoculture.com

Numéro de Pièce	Description	Remarque	QTÉ Kit équipement
508 03 18-10	RÉSERVOIR D'HUILE		1
508 03 19-10	RÉSERVOIR		1
508 04 33-11	POMPE À HUILE		1
508 04 35-02	JOINT TORIQUE		1
508 04 35-03	JOINT TORIQUE		1
508 04 35-05	JOINT TORIQUE		1

www.emc-mooculture.com