

50

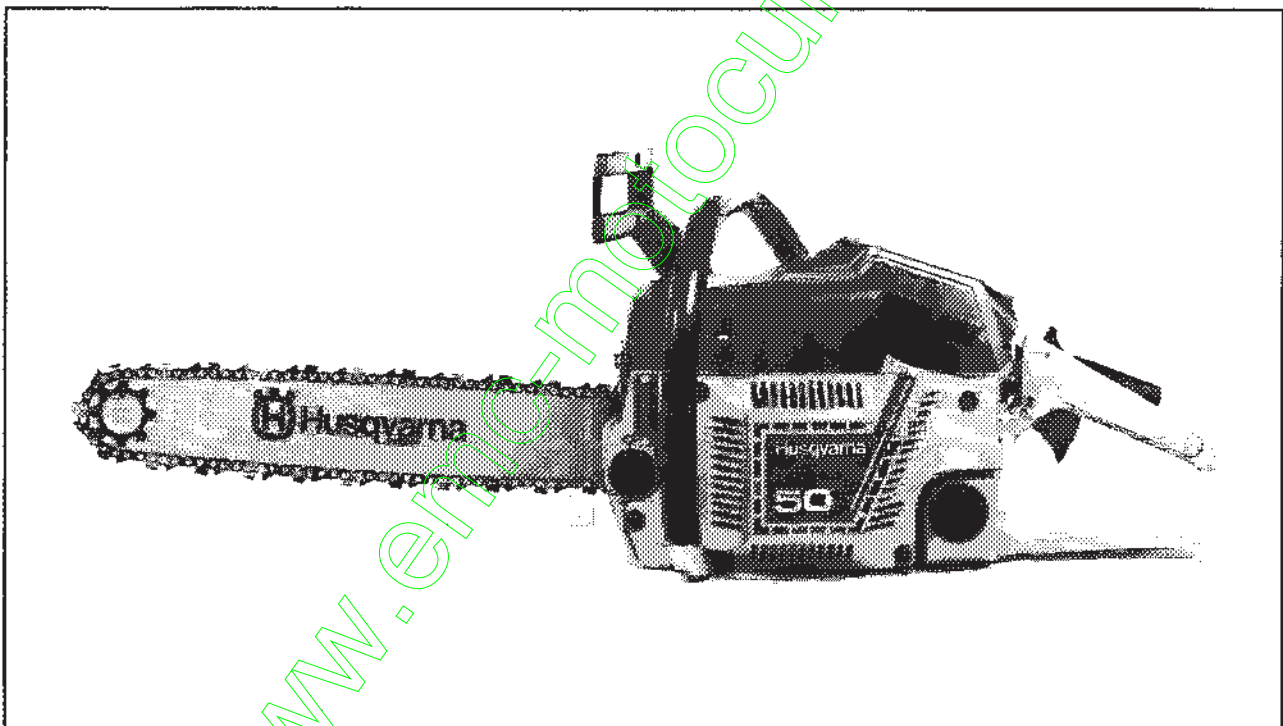

1. 1989

Spare parts

Ersatzteile

Pièces détachées

Repuestos

Reservdelar

A * compl 503 49 81-01
② compl 501 87 84-03

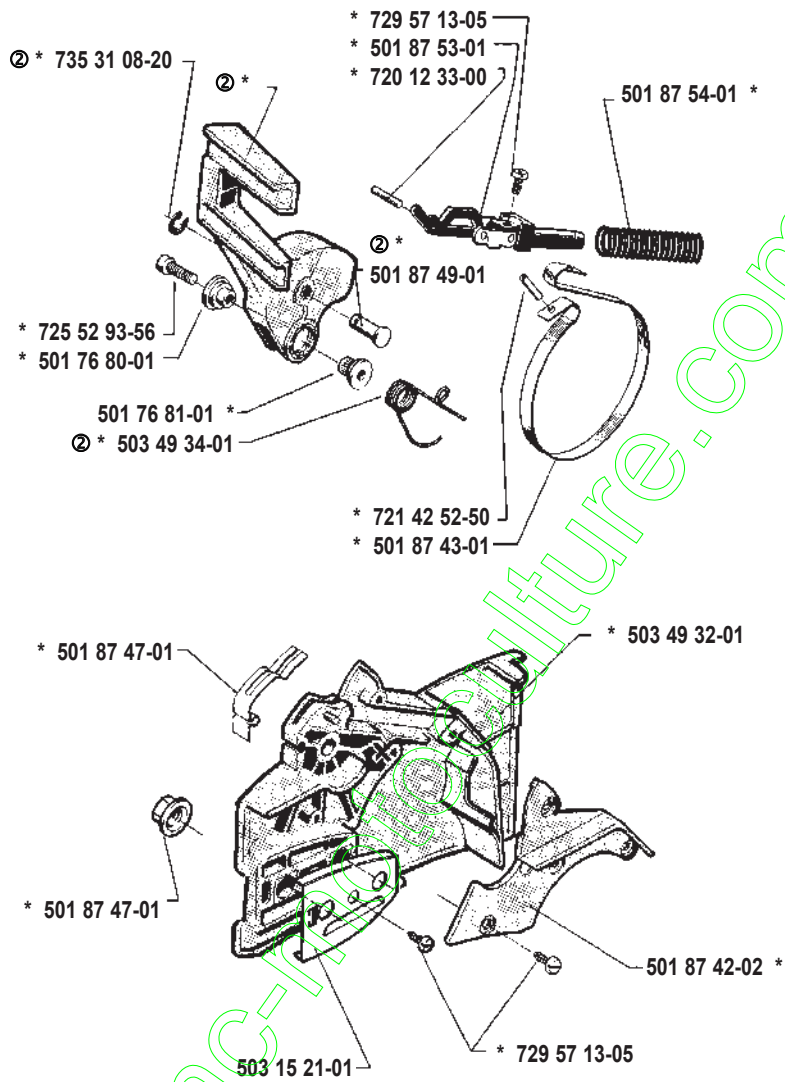

B * compl 503 15 17-03 (USA)
* compl 503 15 17-04

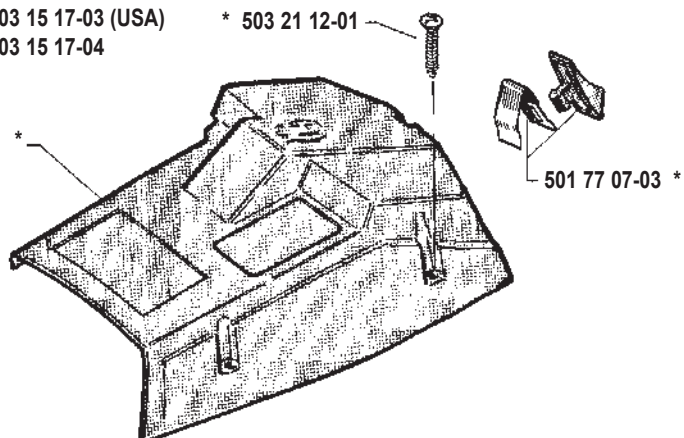

C * compl 503 16 83-01

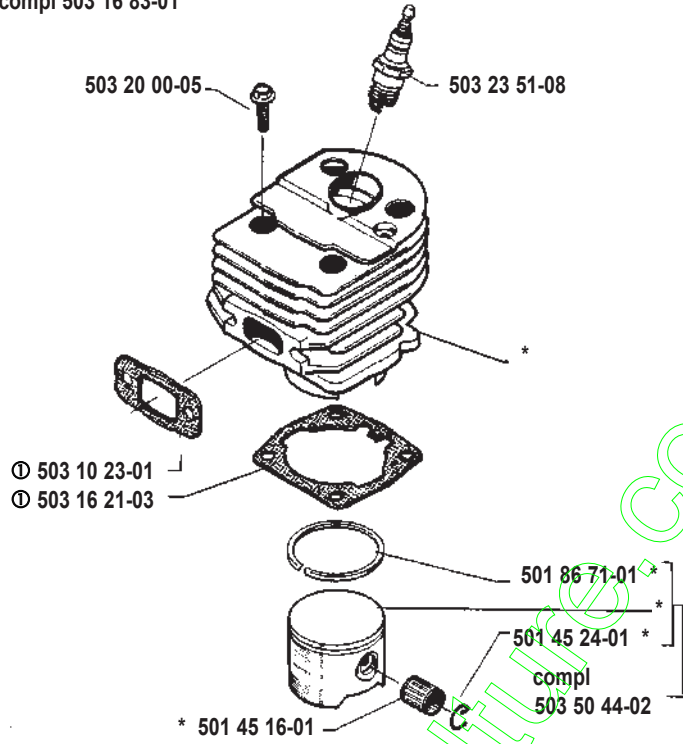

D

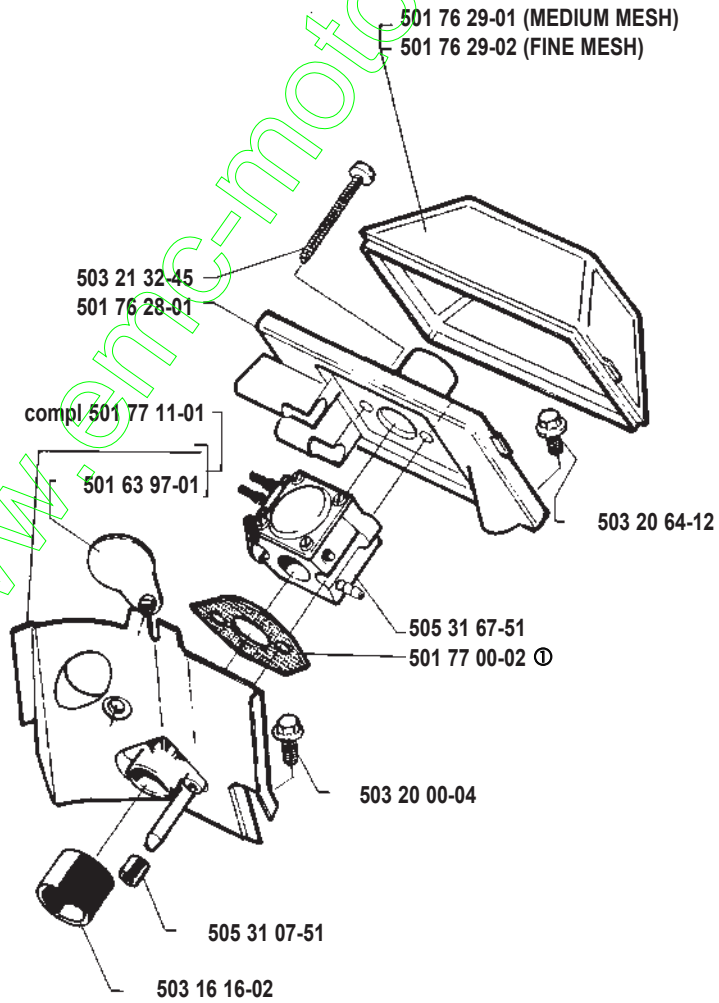

E * compl 501 76 13-06

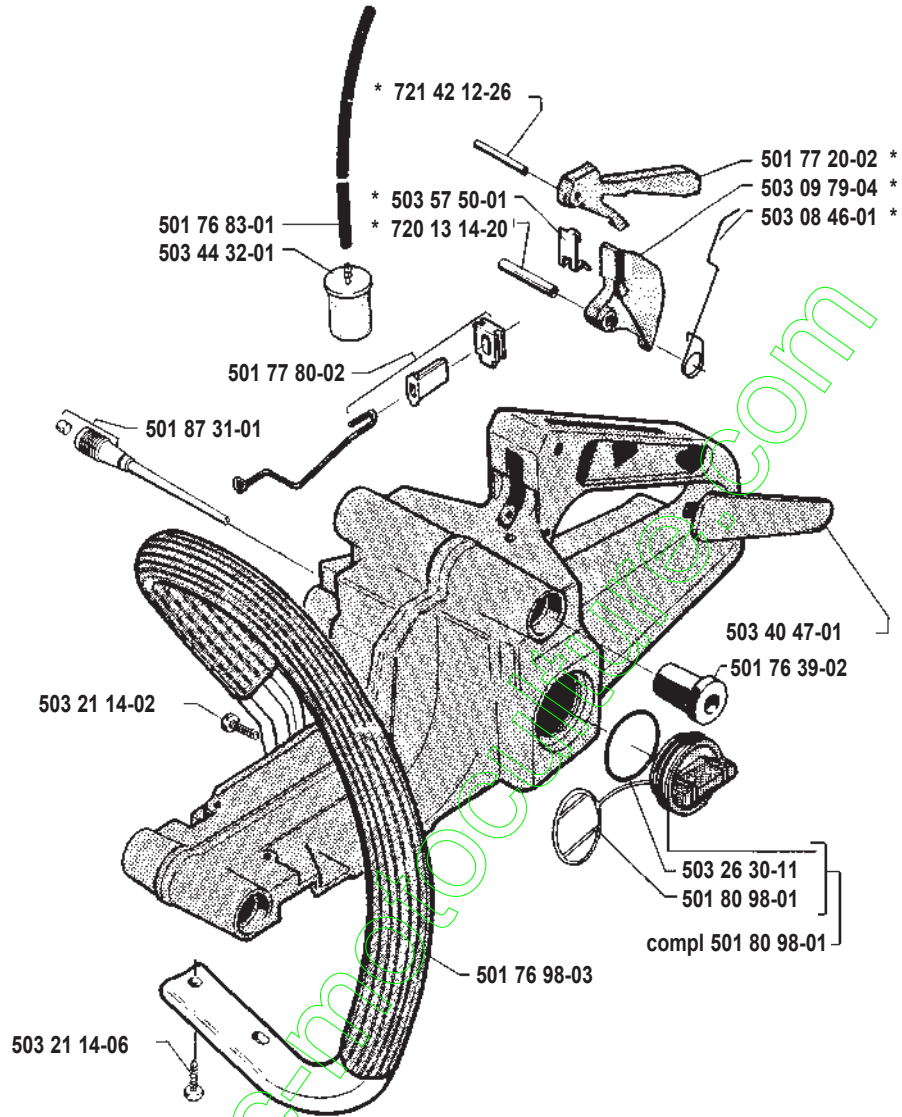

F * compl 501 76 66-02
** compl 501 79 84-01 (USA)

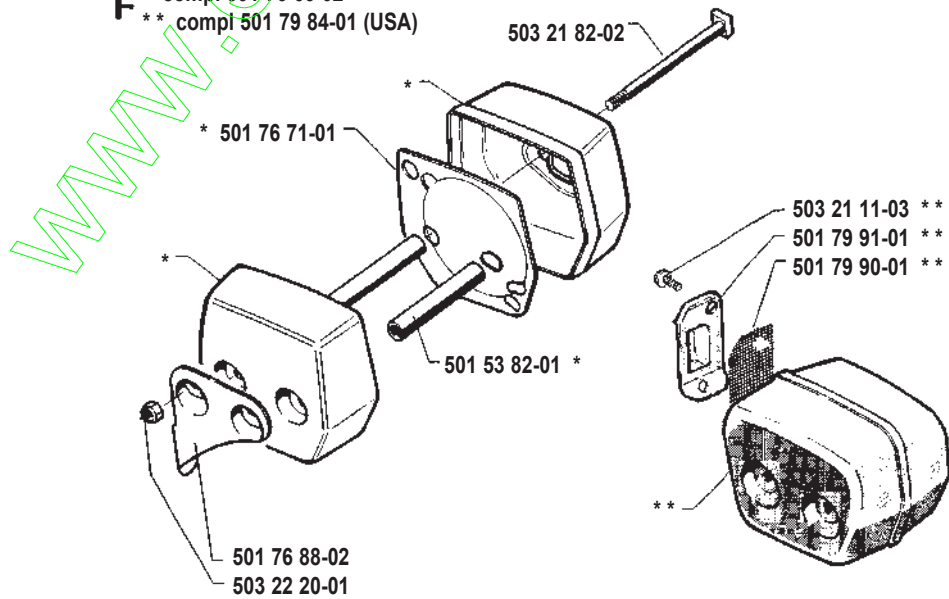

G * compl 503 11 21-01

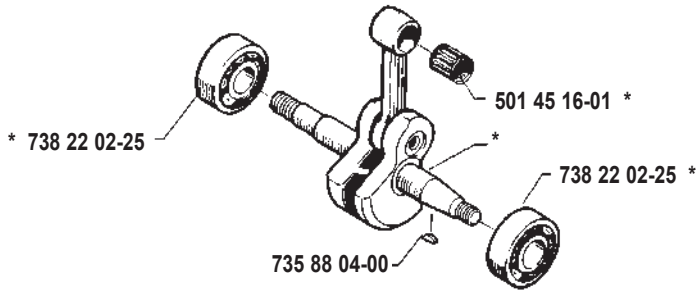

O * compl 501 77 21-01

Vintersats
Winter equipment
Winterausrüstung
Equipment d'hiver

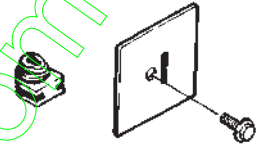

H

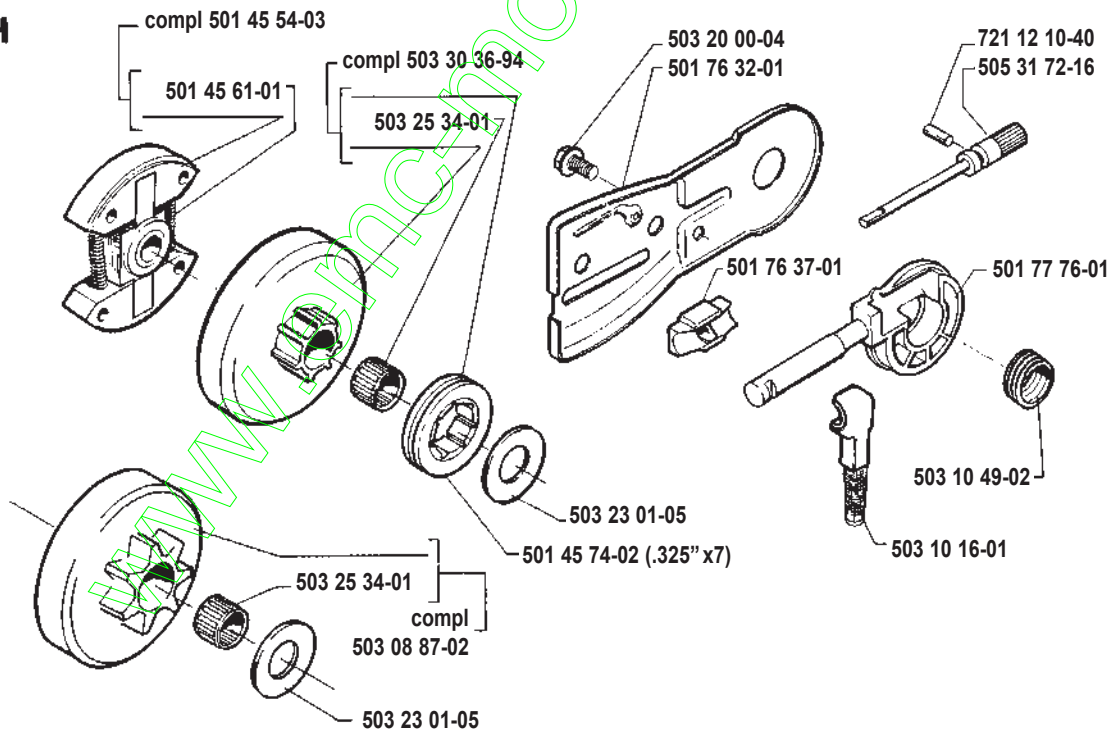

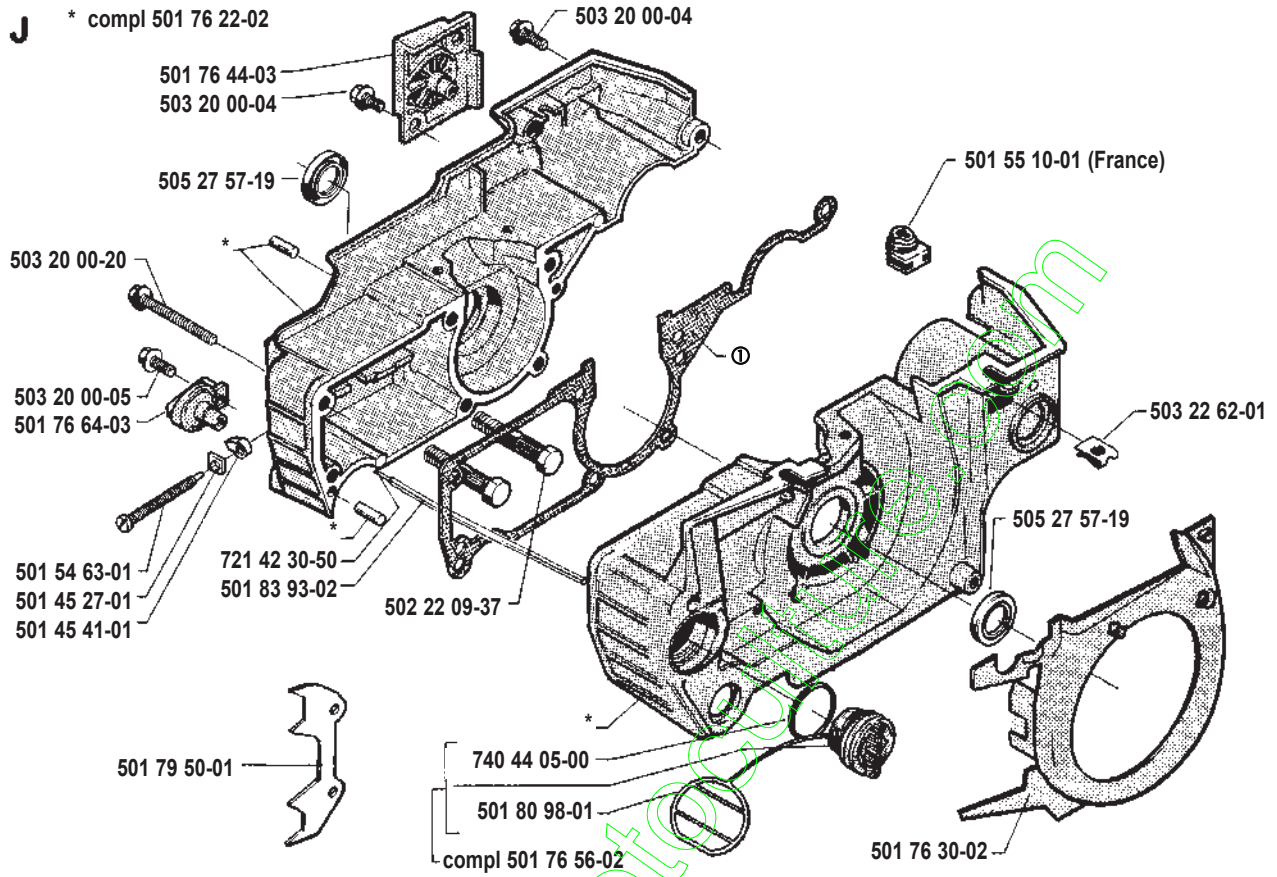

N
Tillbehör
Accessories
Accessoires
Zubehöre

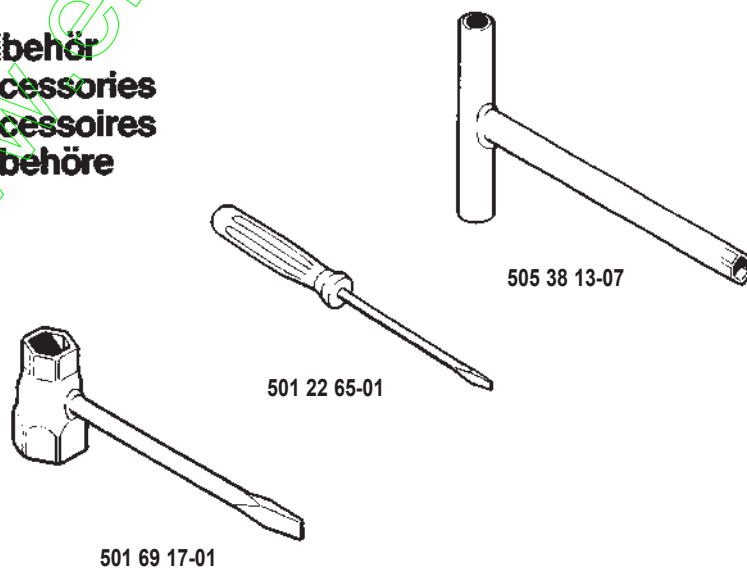

K

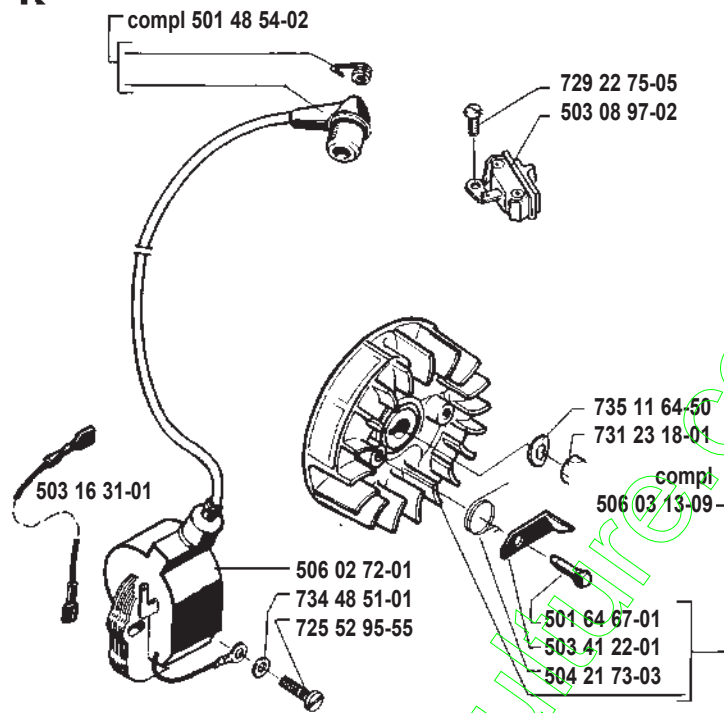

L * compl 503 15 18-01

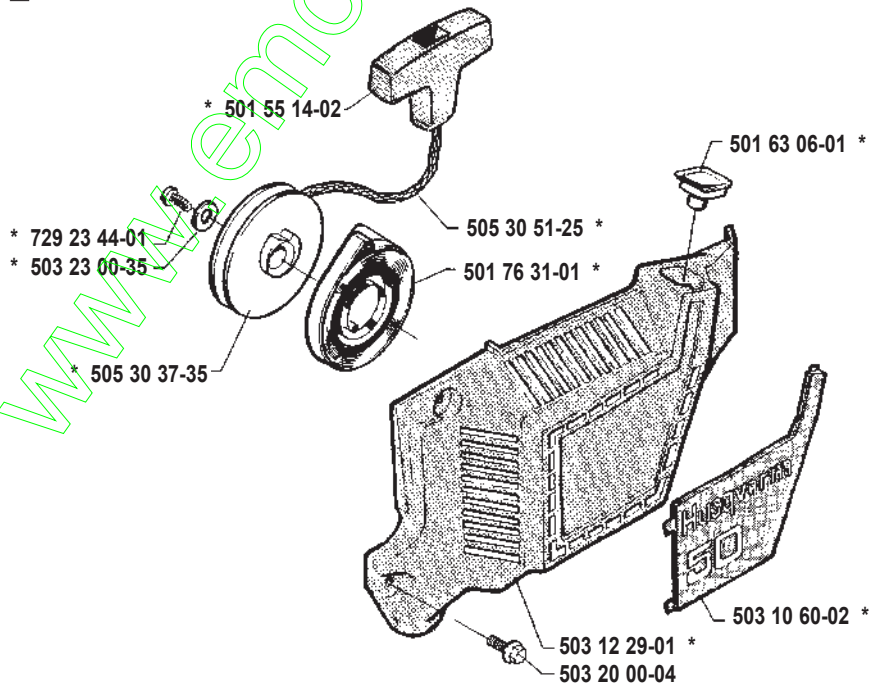

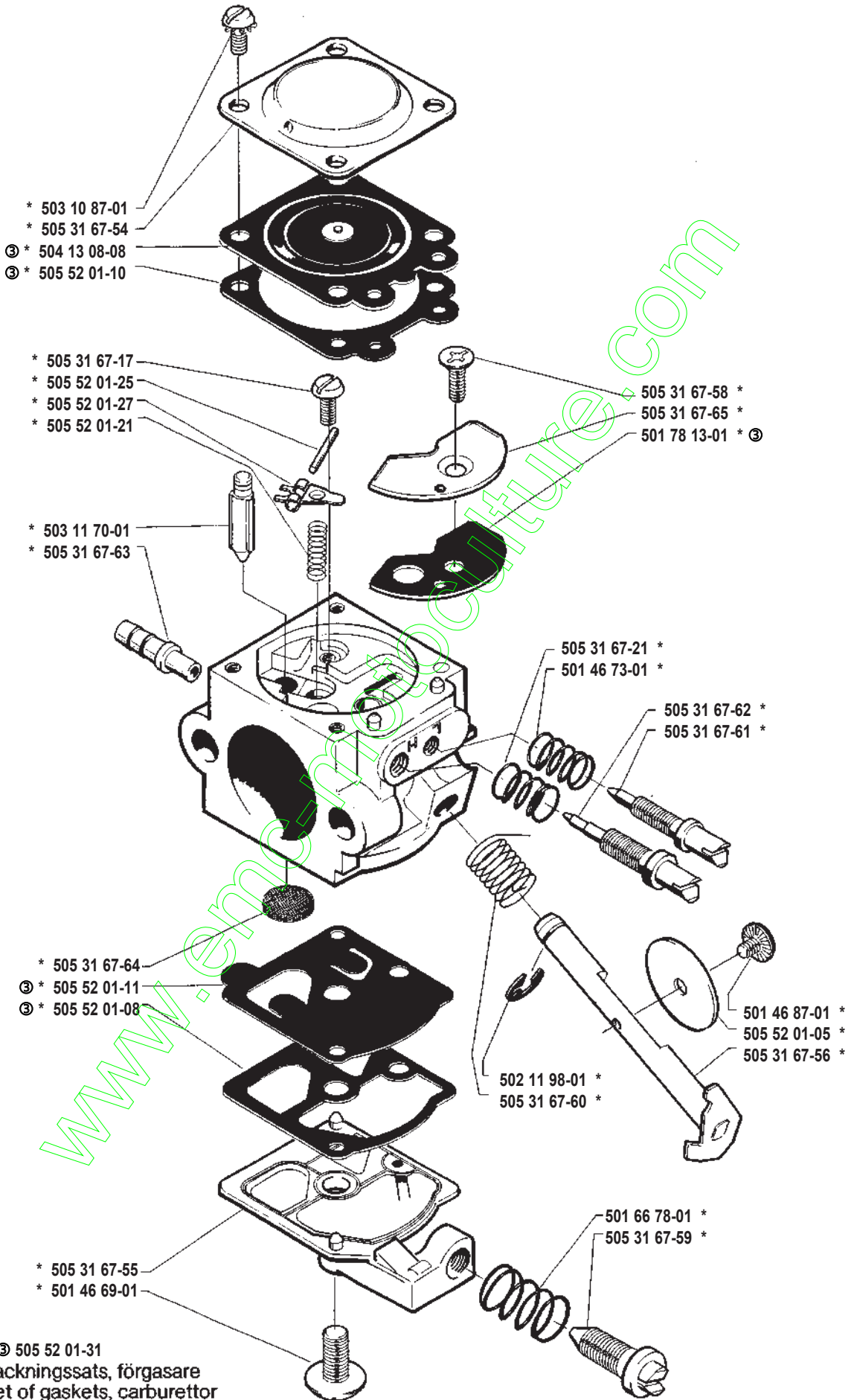

Ref.-No. Teil-Nr. N° de réf. N° ref. Ref. nr.	Square Viereck Carreau Cuadro Ruta	Remark Vermerk Notes Notes Observ. Anm.	Ref.-No. Teil-Nr. N° de réf. N° ref. Ref. nr.	Square Viereck Carreau Cuadro Ruta	Remark Vermerk Notes Notes Observ. Anm.	Ref.-Nr Teil-Nr. N° de réf. N° ref. Ref. nr.	Square Viereck Carreau Cuadro Ruta	Remark Vermerk Notes Notes Observ. Anm.
501 22 65-01	N		501 81 96-02	E		503 50 44-02	C	(N)
501 45 16-01	C, G		501 83 93-02	J		503 57 50-01	E	(N)
501 45 24-01	C		501 86 71-01	C	(N)	504 13 08-08	M	
501 45 27-01	J		501 87 31-01	E		504 21 73-03	K	
501 45 41-01	J		501 87 42-02	A	(N)	505 22 09-37	J	
501 45 54-03	H		501 87 43-01	A	(N)	505 27 57-19	J	
501 45 61-01	H		501 87 47-01	A	(N)	505 30 36-94	H	
501 45 74-02	H		501 87 49-01	A	(N)	505 30 37-35	L	
501 46 69-01	M		501 87 53-01	A	(N)	505 30 51-25	L	
501 46 73-01	M		501 87 54-01	A	(N)	505 31 07-51	D	
501 46 87-01	M		501 87 84-03	A	(N)	505 31 67-17	M	
501 48 54-02	K	(N)	502 11 98-01	M		505 31 67-21	M	
501 53 82-01	F		503 08 46-01	E		505 31 67-51	D, M	
501 54 63-01	J		503 08 87-02	H		505 31 67-54	M	
501 55 10-01	J		503 08 97-02	K	(N)	505 31 67-55	M	
501 55 14-02	L		503 09 79-04	E	(N)	505 31 67-56	M	
501 63 06-01	L		503 10 16-01	H		505 31 67-58	M	
501 63 97-01	D		503 10 23-01	H	(I)	505 31 67-59	M	
501 64 67-01	K		503 10 49-02	H		505 31 67-60	M	
501 66 78-01	M		503 10 60-02	L		505 31 67-61	M	
501 69 17-01	N		503 10 87-01	M		505 31 67-62	M	
501 76 13-06	E		503 11 21-01	G		505 31 67-63	M	
501 76 18-02	-	(I)	503 11 70-01	M	(N)	505 31 67-64	M	
501 76 22-02	J		503 12 29-01	L		505 31 67-65	M	
501 76 28-01	D		503 15 17-04	B		505 31 72-16	H	
501 76 29-01	D		503 15 18-01	L		505 38 13-07	N	
501 76 29-02	D	(N)	503 15 21-01	A		505 52 01-05	M	
501 76 30-02	J		503 16 16-02	D		505 52 01-08	M	
501 76 31-01	L		503 16 21-03	C	(I)	505 52 01-10	M	
501 76 32-01	H		503 16 31-01	K		505 52 01-11	M	
501 76 37-01	H		503 16 83-01	C	(N)	505 52 01-21	M	
501 76 39-02	E		503 20 00-04	D, H, J, L		505 52 01-25	M	
501 76 44-03	J		503 20 00-05	C, J		505 52 01-27	M	
501 76 56-02	J		503 20 00-20	J		505 52 01-31	M	
501 76 64-03	J		503 20 64-12	D		506 02 72-01	K	
501 76 66-02	F	(N)	503 21 11-03	F	(N)	506 03 13-09	K	
501 76 71-01	F		503 21 12-01	B		720 12 33-00	A	(N)
501 76 80-01	A		503 21 14-02	E		720 13 14-20	E	
501 76 81-01	A		503 21 14-06	E		721 12 10-40	H	
501 76 83-01	E		503 21 32-45	D		721 42 12-26	E	
501 76 88-02	F		503 21 82-02	F		721 42 30-50	J	
501 76 98-03	E		503 22 00-01	A		721 42 52-50	A	
501 77 00-02	D	(I)	503 22 20-01	F		725 52 93-56	A	
501 77 07-03	B	(N)	503 22 62-01	J		725 52 95-55	K	
501 77 11-01	D		503 23 00-35	L		729 22 75-05	K	
501 77 20-02	E		503 23 01-05	H		729 23 44-01	L	
501 77 21-01	O		503 23 51-08	C	(N)	729 57 13-05	A	(N)
501 77 76-01	H		503 25 34-01	H		731 23 18-01	K	
501 77 80-02	E		503 26 30-11	E		734 48 51-01	K	
501 78 13-01	M		503 40 47-01	E		735 11 64-50	K	
501 79 50-01	J		503 41 22-01	K		735 31 08-20	A	(N)
501 79 84-01	F	(N)	503 44 32-01	E		735 88 04-00	G	
501 79 90-01	F	(N)	503 49 32-01	A	(N)	738 22 02-25	G	
601 79 91-01	F	(N)	503 49 34-01	A	(N)	740 44 05-00	J	
501 80 98-01	E, J		503 49 81-01	A	(N)			

(I) = 501 76 18-02
Set of gaskets
Dichtungssatz
Jeu de joints
Juego de juntas
Packningssats

(N) = Newpart
Neues Teil
Nouvelle pièce
Nueva pieza
Ny det.