

REPAIR PARTS MANUAL
MODEL NO. 253714

CRAFTSMAN[®]

581897526

HOW TO USE THIS MANUAL

This manual is designed to provide the customer with a means to identify the parts on his/her tractor when ordering repair parts. The illustrations may or may not represent the actual assemblies; therefore, it is not recommended to use this manual as a guide to assemble or disassemble the tractor. Some hardware and parts are drawn larger in order to more readily identify them.

Each tractor has its own model number.

The model number for your tractor can be found on the fender under the seat.

When ordering parts, always give the following information:

- Product - Lawn Tractor
- MODEL NUMBER - **253714**
- Part Number
- Part Description

TABLE OF CONTENTS

SCHEMATIC	3
ELECTRICAL.....	4-5
CHASSIS	6-7
DRIVE.....	8-9
ENGINE.....	10-11
STEERING	12
SEAT	13
MOWER DECK	14-15
MOWER LIFT.....	16
DECALS.....	17
TRANSAXLE BREAKDOWN	18-19
ENGINE BREAKDOWN.....	20-26
WARRANTY.....	27

TRACTOR - - MODEL NUMBER 917.253714

SCHEMATIC

SCH12

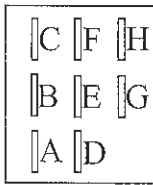
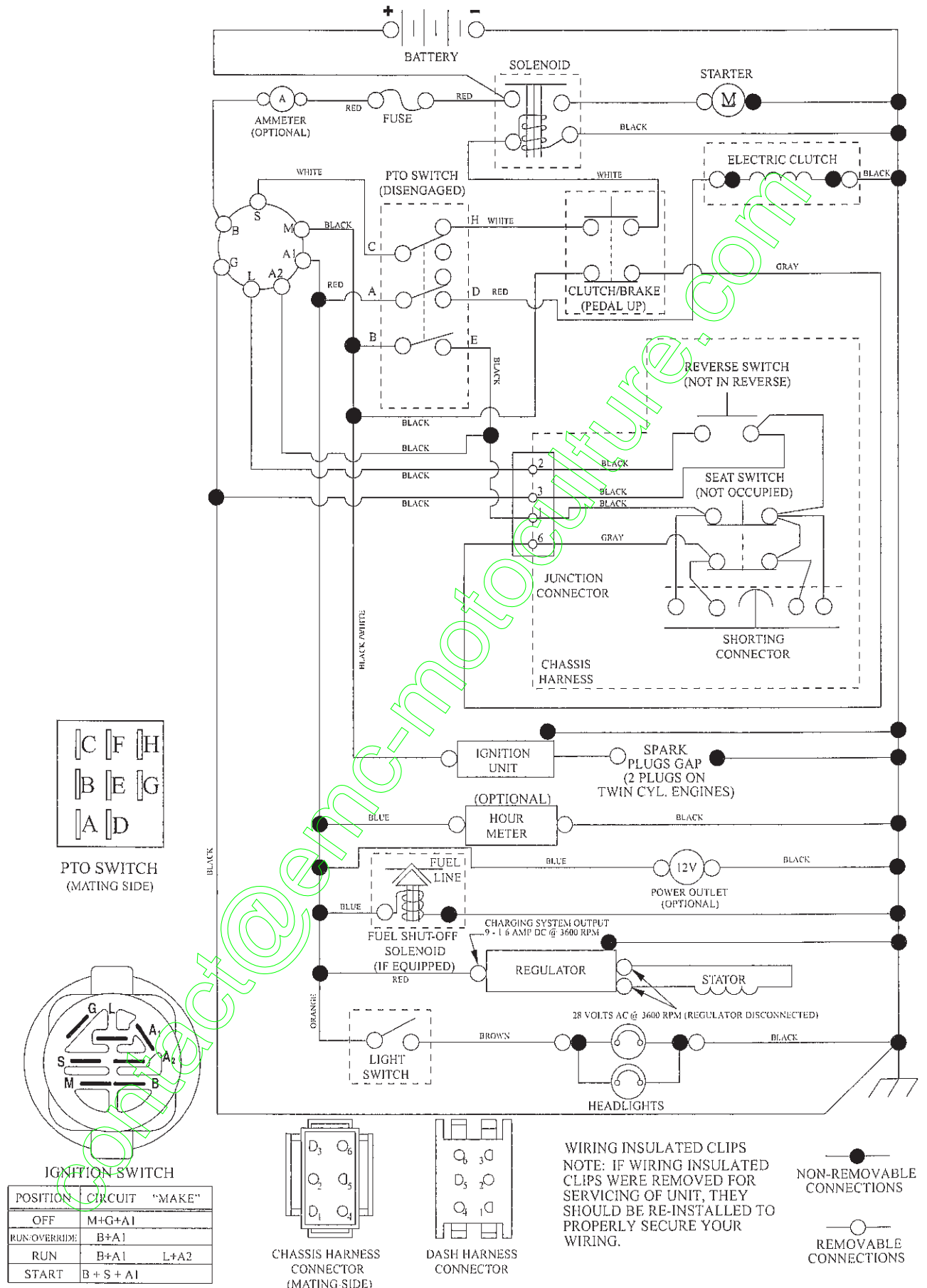

PTO SWITCH (MATING SIDE)

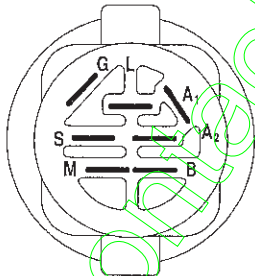

IGNITION SWITCH

POSITION	CIRCUIT	"MAKE"
OFF	M+G+A1	
RUN-OVERRIDE	B+A1	
RUN	B+A1	L+A2
START	B + S + A1	

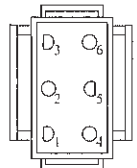

CHASSIS HARNESS CONNECTOR (MATING SIDE)

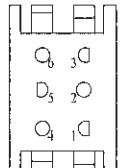

DASH HARNESS CONNECTOR

WIRING INSULATED CLIPS
 NOTE: IF WIRING INSULATED CLIPS WERE REMOVED FOR SERVICING OF UNIT, THEY SHOULD BE RE-INSTALLED TO PROPERLY SECURE YOUR WIRING.

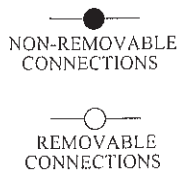

TRACTOR - - MODEL NUMBER 917.253714

ELECTRICAL

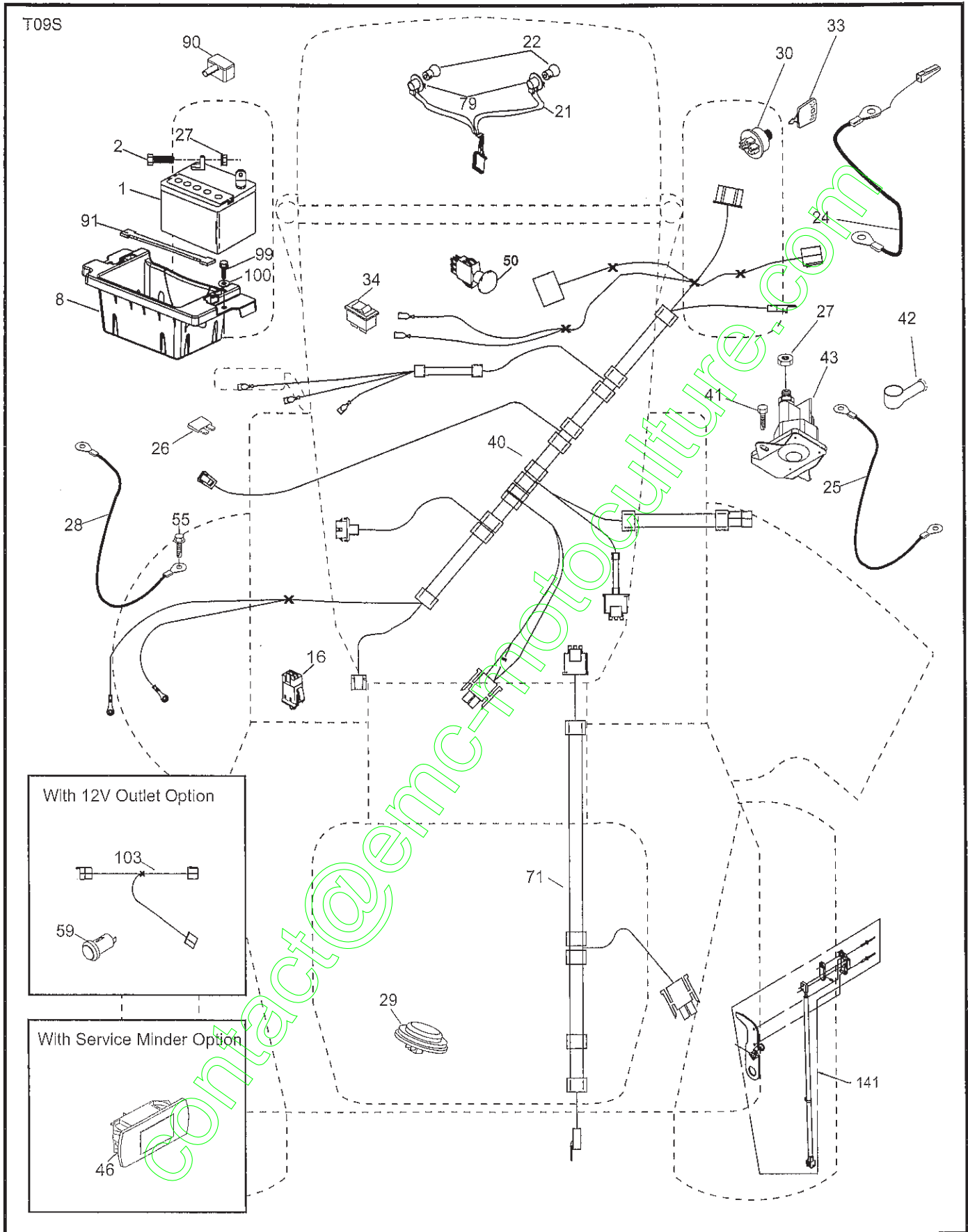

KEY NO.	PART NO.	DESCRIPTION
1	163465	Battery
2	74760412	Bolt Hex Head 1/4-20 x 3/4
8	186491	Box Battery
16	176138	Switch Interlock Push-In
21	400252	Harness Socket Light w/4152J
22	4152J	Bulb Light
24	400253	Cable Battery
25	412895	Cable Starter
26	175158	Fuse
27	73510400	Nut Keps Hex 1/4-20 unc
28	145491	Cable, Ground
29	401545	Switch, Seat
30	193350	Switch, Ign
33	411934	Key/Chain
34	110712X	Switch Light/Reset
40	401104	Harness Ign. Dash
41	17720408	Screw 1/4-20 x 1/2
42	131563	Cover, Terminal
43	192507	Solenoid
46	401763	Gauge Hourmeter
50	174652	Switch, PTO
55	17060512	Screw 5/16-18 x 3/4
71	194276	Harness Ignition Chassis
79	175242	Socket Asm. Bulb
90	435395	Cover Terminal Battery
91	190270	Strap Battery Mount Front
99	17670412	Screw Hexwsh Thdrol 1/4-20 x 3/4
100	19091416	Washer 9/32 x 7/8 x 16 Ga.
141	421225	Kit G700/G730 ROS Service

NOTE: All component dimensions given in U.S. inches
1 inch = 25.4 mm

TRACTOR -- MODEL NUMBER 917.253714

CHASSIS ASSEMBLY

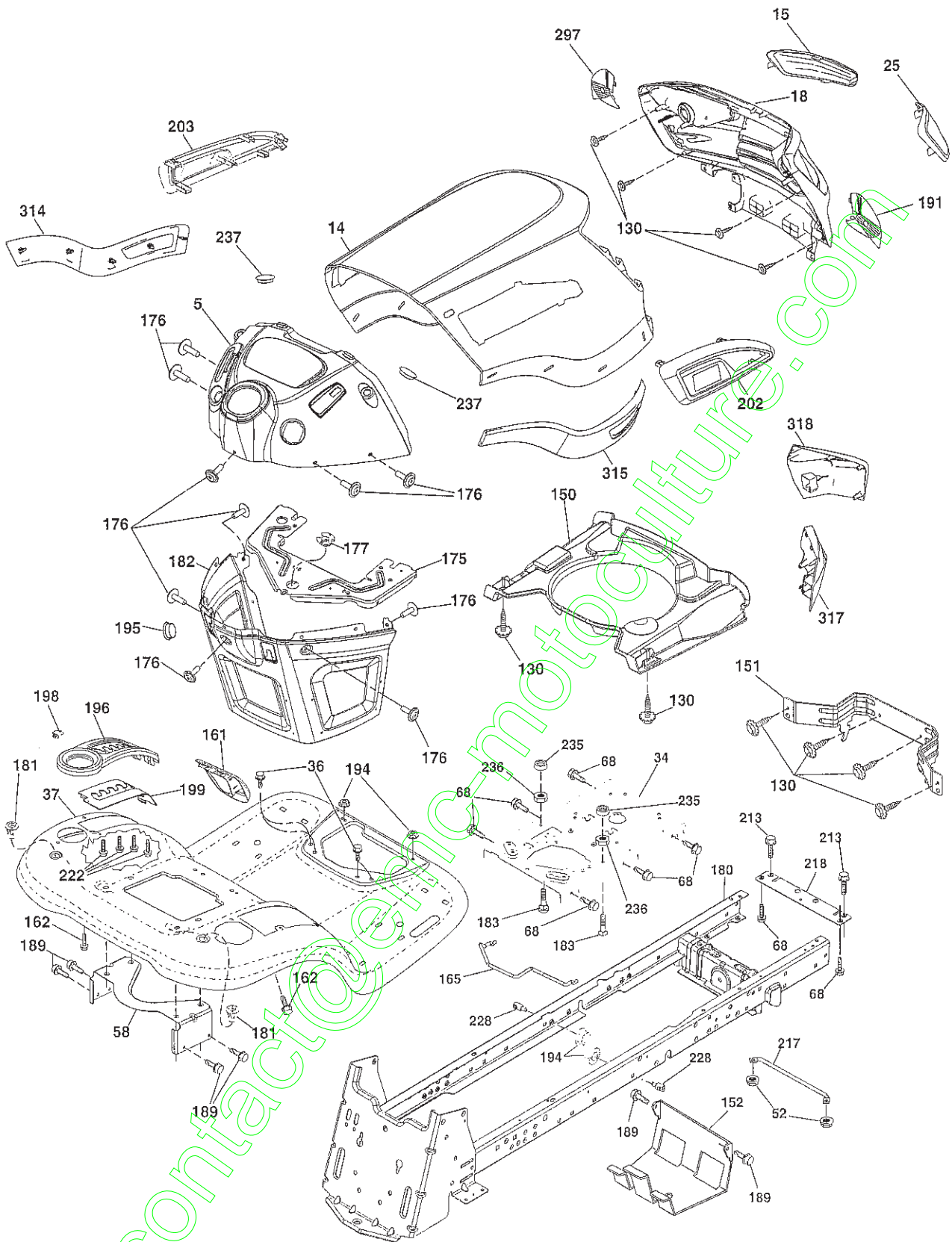

chassis-tex_PRED II GT_1

TRACTOR - - MODEL NUMBER 917.253714

CHASSIS ASSEMBLY

KEY NO.	PART NO.	DESCRIPTION	KEY NO.	PART NO.	DESCRIPTION
5	421811X428	Dash	191	425407	Insert Reflective RH
14	421154X428	Hood	194	73900500	Nut Lock Hex Flange 5/16-18
15	421493X599	Lens LH	195	401556X428	Plug Hole Dash
18	423158	Grille	196	196379X428	Console Asm. Deck Lift
25	421494X599	Lens RH	198	197300X667	Indicator Deck Lift
34	580910801	Plate Engine	199	196377	Plate Deck Lift
36	17060512	Screw 5/16-18 x 3/4	202	44172X428	Vent Side Hood RH
37	400009X428	Fender	203	441729X428	Vent Side Hood LH
52	73680500	Nut Lock 5/16-18	213	74760512	Bolt 5/16-18 unc x 3/4
58	194314	Brack Support Fender	217	409167	Rod Pivot Hood
68	17490508	Screw Thdrol 5/16-18 x 1/2	218	196395	X-Piece Hood Stop
130	416358	Screw #10 x 0.750	222	137729	Screw 1/4-20 x 5/8
150	199411	Duct Heat Hood	228	195161	Stud Fastener
151	445494	Bracket Pivot	235	406129	Spacer Fender
152	199535	Shield Browning/Debris	236	73930500	Nut 5/16-18 unc
161	193097X428	Window Fuel	237	403704	Plug Mount Cargo
162	142432	Screw Hex Wsh Hi-Lo 1/4 x 1/2	297	425406	Insert Reflective LH
165	196826	Support Tank Rear	314	426570	Trim Side LH
175	196304	Crossmember	315	426571	Trim Side RH
176	400776	Screw	317	421257X428	Cap Corner RH
177	195227	Bushing Steering	318	421258X428	Cap Corner LH
180	195477	Chassis			
181	193102X428	Bushing Mtg. Fender Crgo.			
182	406859	Dash Lower			
183	74520520	Bolt 5/16-18 x 1-1/4			
189	17000512	Screw 3/8-16 x 3/4			

NOTE: All component dimensions given in U.S. inches
1 inch = 25.4 mm

contact@emc-motors.com

TRACTOR - - MODEL NUMBER 917.253714

GROUND DRIVE

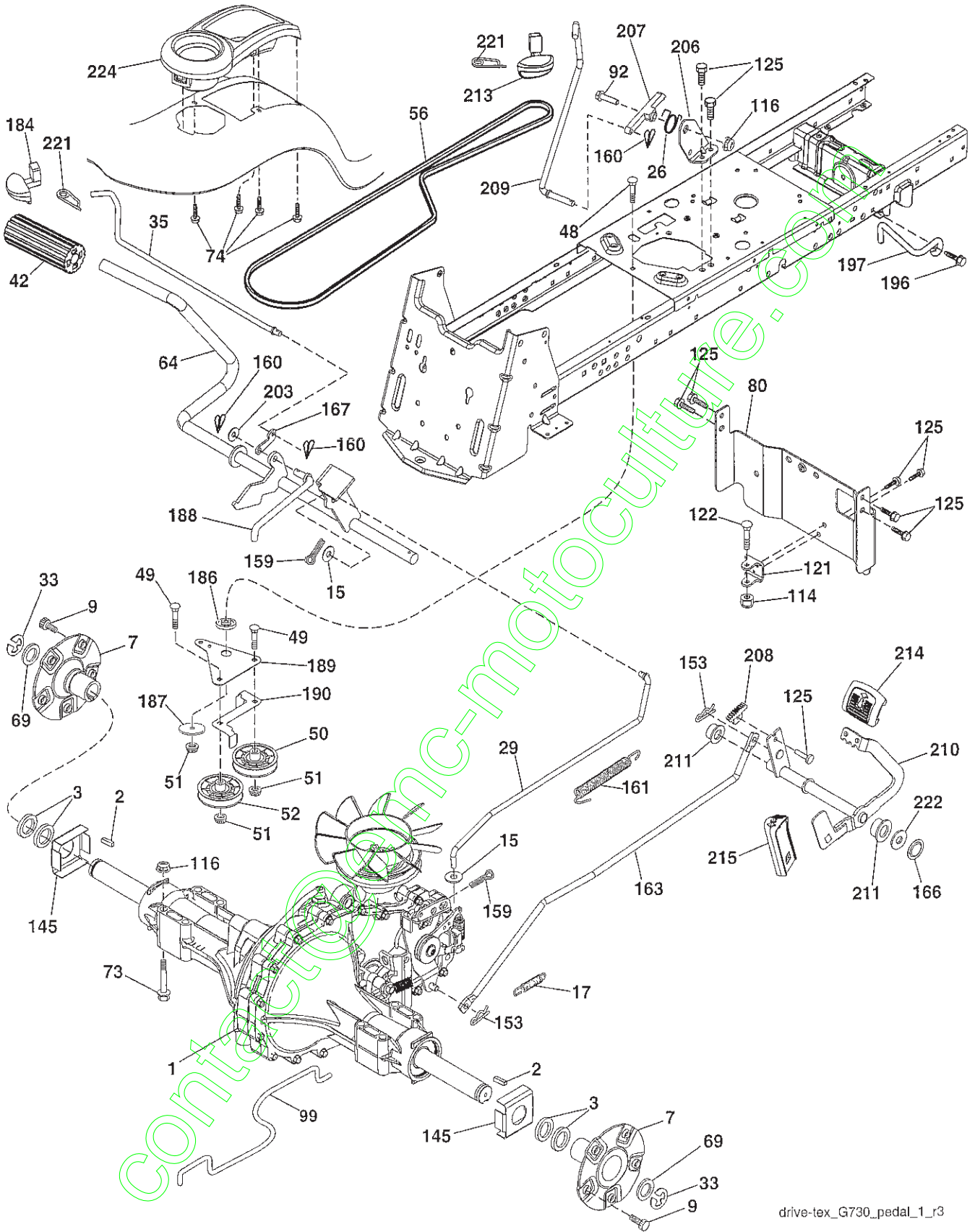

drive-tex_G730_pedal_1_r3

TRACTOR - - MODEL NUMBER 917.253714

GROUND DRIVE

KEY NO.	PART NO.	DESCRIPTION	KEY NO.	PART NO.	DESCRIPTION
1	---	Transaxle, Hydro Gear G7-BCBB-1XDC-1FCA (420331) (See Transaxle Breakdown.)	159	76020412	Pin Cotter 1/8 x 3/4
2	7070E	Key 1/4 x 2.5	160	169484	Retainer Clip
3	7563R	Washer Thrust Axle Hardened	161	105709X	Spring, Return, Clutch
7	199837	Hub Asm. Wheel	163	418185	Rod Pedal Control
9	140080	Bolt Hub Wheel	166	429164	Nut Push .625
15	19131316	Washer 13/32 x 13/16 x 16 Ga.	167	405257	Latch Brake Parking
17	197296	Spring, Brake	184	196439X667	Handle Parking Brake
26	199679	Spring Return Cruise	186	194321	Spacer Retainer
29	418186	Rod, Brake	187	19133210	Washer
33	12000053	Ring E	188	194323	Link Clutch Ground Drive
35	435486	Rod, Brake, Park	189	407504	Bellcrank Ground Drive
42	8883R	Cover, Foot Pedal	190	407505	Keeper Bellcrank Ground Drive
48	72110612	Bolt Carr Sh 3/8-16 x 1-1/2 Gr. 5	196	17000616	Screw 3/8-16 x 1
49	72110614	Bolt	197	199769	Bracket Clutch Anti-Rotation
50	194327	Pulley Idler Flat	203	19111116	Washer 11/32 x 11/16 x 16 Ga.
51	73900600	Lock Nut 3/8-16	206	44 85-96	Bracket Mount Latch Cruise
52	194326	Idler V-Groove 910" Offset	207	197868	Latch Control Cruise
56	420807	V-Belt, Drive	208	197869	Gear Sector Control Cruise
64	197865	Shaft Asm. Pedal Brake Control	209	199592	Rod Control Cruise
69	123800X	Washer 1-1/32 x 1-5/8 x 16 Ga.	210	197860	Rocker Asm. Pedal Control
73	74490548	Bolt Hex 5/16-18 x 3 Gr. 5	211	120183X	Bearing Nylon
74	142432	Screw 1/4 x 1/2	213	196441X428	Knob Control Cruise
80	418184	Strap Torque	214	421263	Pedal Forward
92	74760520	Bolt 5/16-18 x 1/2	215	197301X428	Pedal Reverse
99	418188	Spring Bypass	221	403187	Retainer Spring Clip Handle
114	73800500	Nut Lock Hex W/Ins. 5/16-18 unc	222	79212010	Washer 21/32 x 1-1/4 x 10 Ga.
116	73900500	Nut Lock Hex Flange 5/16-18	224	193099X428	Console Toolbox
121	175611	Bracket Strap Torque	306	76020416	Pin Cotter
122	72010520	Bolt 5/16-18 x 2.50			
125	17000512	Screw 5/16-18 x 3/4			
145	163168	Washer Axle Flange			
153	4497H	Retainer Spring			

NOTE: All component dimensions given in U.S. inches
1 inch = 25.4 mm

TRACTOR - - MODEL NUMBER 917.253714

ENGINE

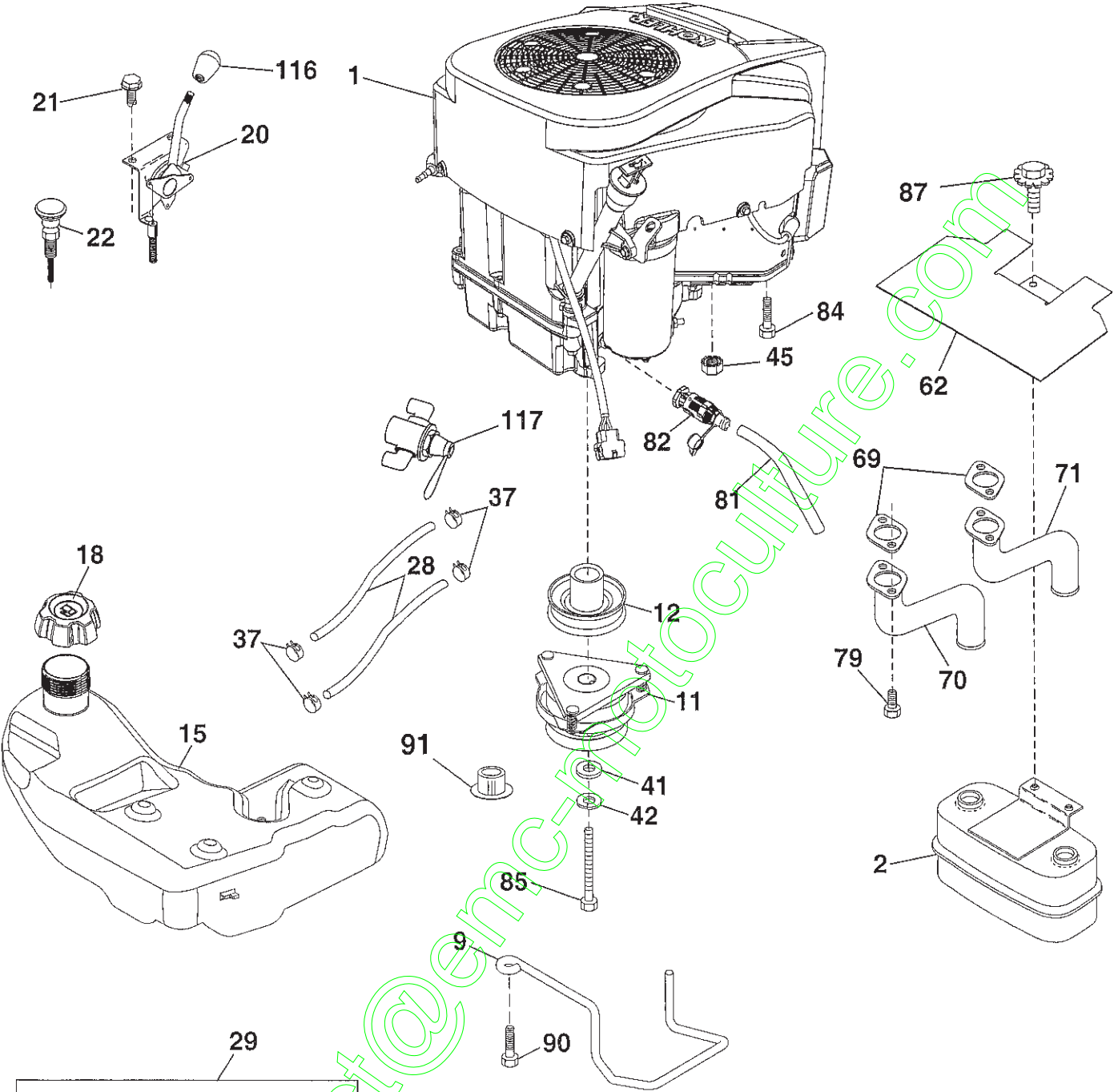

SPARK ARRESTER KIT

engine-tex_Kohl-2cyl_4_r2

TRACTOR - - MODEL NUMBER 917.253714

ENGINE

KEY NO.	PART NO.	DESCRIPTION
1	- - - -	Engine Kohler Model No. SV735 -3019 (438354)(See Engine Breakdown.)
2	149723	Muffler
9	408667	Keeper Belt Engine
11	179335	Clutch Electric
12	194343	Pulley Engine
15	422804	Tank Fuel 4.0
18	430218	Cap Asm
20	426184	Control Throttle
21	416358	Screw 10 x .750 BOS Thread
22	187767X428	Control Choke
28	8543R	Fuel Line
29	137180	Spark Arrester Kit
37	123487X	Clamp Hose
41	126197X	Washer 1-1/2 OD x 15/32 ID x .250
42	10040700	Washer Lock 7/16
45	73510400	Nut Keps Hex 1/4-20 unc
62	434017	Shield Heat Muffler
69	- - - - -	Gasket (Order from Eng. Mfgr.)
70	146699	Tube Exhaust LH
71	146700	Tube Exhaust RH
79	192334	Screw 5/16-18 x 3/4
81	148456	Tube Drain Oil Easy
82	428287	Valve Drain Oil
84	17120616	Screw 3/8-16 x 1
85	179953	Bolt Hex 7/16-20 x 3.75 Gr. 5
87	198239	Bolt 5/16-18 unc x 1 w/Sems
90	17000616	Screw 3/8-16 x 1
91	187495	Bushing
116	423109X659	Knob Oval Tapered 3/8-16
117	420828	Value Fuel Reserve

NOTE: All component dimensions given in U.S. inches
1 inch = 25.4 mm

TRACTOR - - MODEL NUMBER 917.253714

STEERING ASSEMBLY

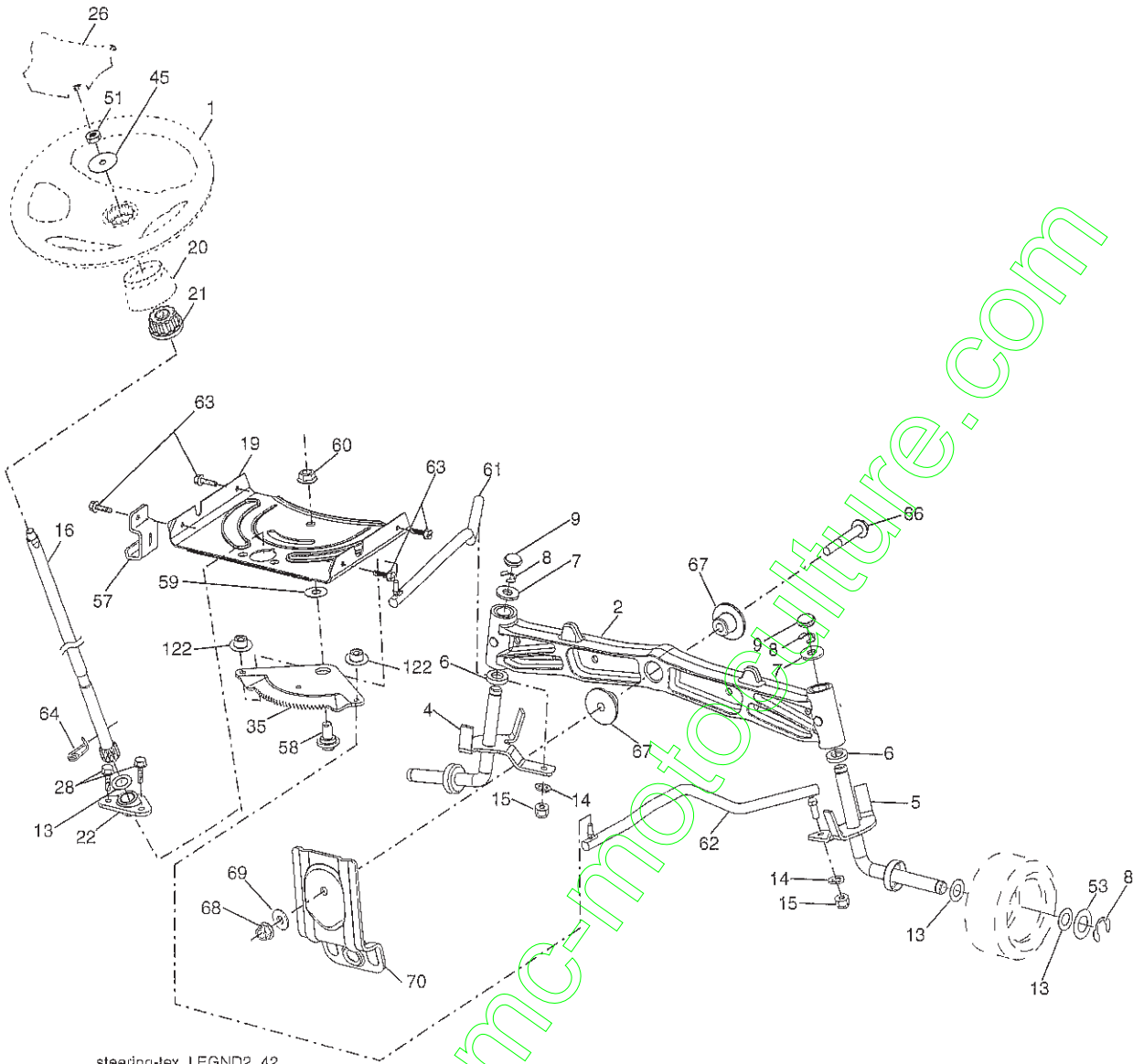

steering-tex_LEGND2_42

KEY NO.	PART NO.	DESCRIPTION
1	414851X659	Wheel, Steering
2	195968	Axle Asm., Front
4	403089	Spindle Asm., LH
5	403090	Spindle Asm., RH
6	6266H	Bearing, Race Thrust Harden
7	121748X	Washer 25/32 x 1-5/8 x 16 Ga.
8	12000029	Ring, Clip #175304-75
9	184946X667	Cap, Spindle
13	121749X	Washer 25/32 x 1-1/4 x 16 Ga.
14	STD551137	Washer Lock Hvy Hicl Spr 3/8
15	73540600	Nut, Crown Lock 3/8-24 unf
16	194746	Shaft Steering
19	194729	Plate Steering
20	199676X428	Boot, Steering
21	186737	Adapter, Wheel Steering
22	420537	Support Strg. Lower
26	414852X659	Insert, Wheel Steering
28	17000612	Screw 3/8-16 x 3/4
35	194732	Gear, Sector Plate
45	19183812	Washer 9/16 x 2-3/8 x 12 Ga.

KEY NO.	PART NO.	DESCRIPTION
51	73940800	Nut Hex Jam Toplock 1/2-20 unf
53	188967	Washer Hardened .793 x 1.637 x .060
57	197246	Bracket Upstop
58	194747	Bolt Shoulder Sector Pivot CFM
59	194748	Washer Thrust Sector Steering
60	73971000	Nut Flange Lock 5/8-11
61	194740	Draglink, LH
62	194741	Draglink, RH
63	17000512	Screw 5/16-18 x 3/4
64	199849	Retainer Clip Spring Steering
66	71020748	Bolt Hex Fghd 7/16-14 x 3 Serr
67	194737	Bushing PM Front Axle
68	73900700	Nut Lock Flange 7/16-14 Gr. 5
69	199162	Washer 1.5 x .505 x .118
70	196197	Bracket Deck Susp. Front
122	444962	Cap Gear Sector

NOTE: All component dimensions give in U.S. inches
1 inch = 25.4 mm

TRACTOR - - MODEL NUMBER 917.253714

SEAT ASSEMBLY

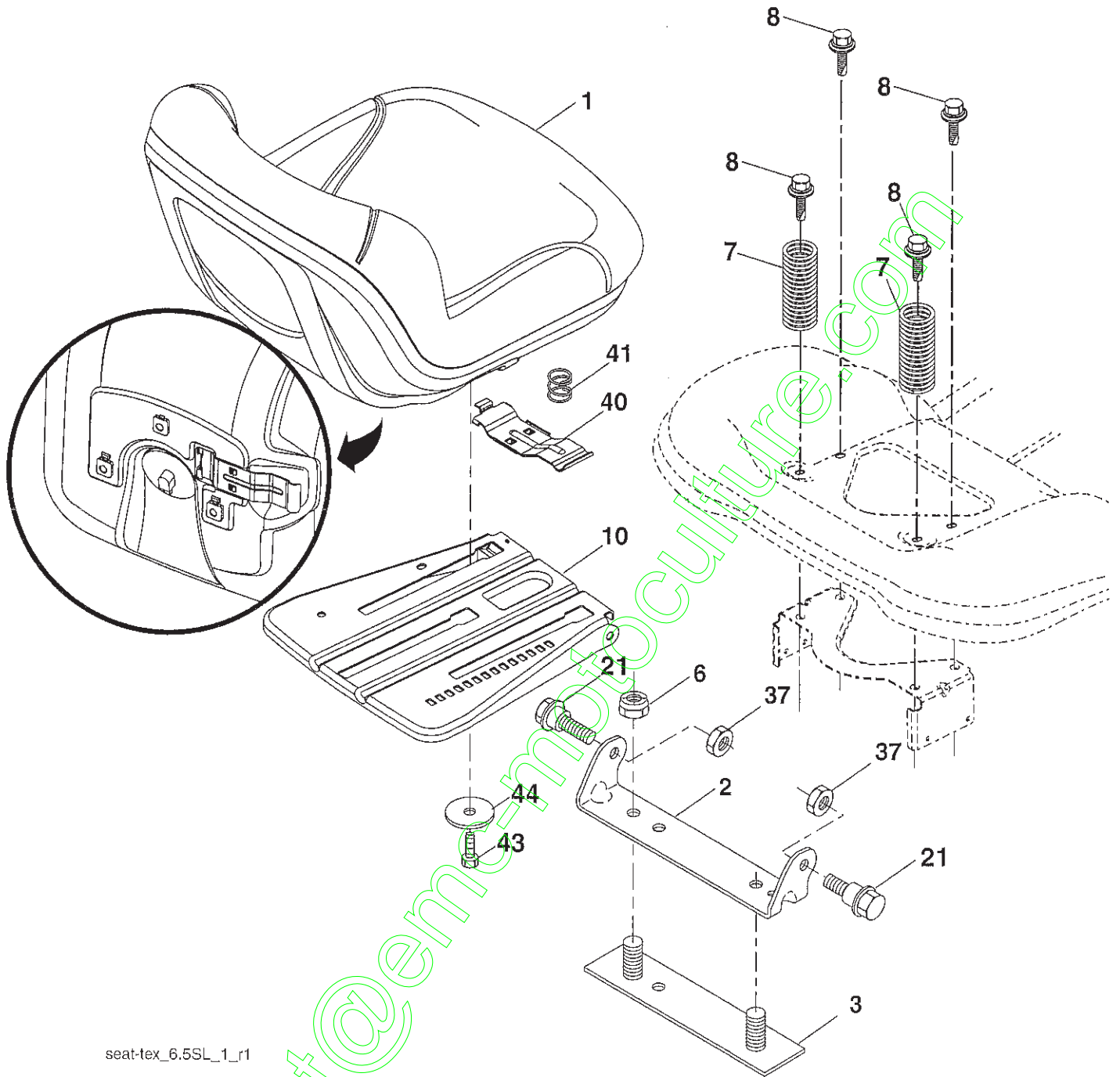

seat-tex_6.5SL_1_r1

KEY NO.	PART NO.	DESCRIPTION
1	423810	Seat
2	180166	Bracket Pivot Fender
3	140675	Strap, Asm Fender
6	STD541437	Nut, Lock w/Ins. 3/8-16 unc
7	124181X	Spring, Seat Cprsn
8	171877	Bolt 5/16-18 unc x 3/4 w/Sems
10	196977	Pan, Seat
21	171852	Bolt, Shoulder 5/16-18
37	STD541431	Nut, Lock 5/16-18 unc

KEY NO.	PART NO.	DESCRIPTION
40	197661	Handle Slide Seat
41	198200	Spring Latch Seat
43	74760612	Bolt 3/8-16 unc x 3/4
44	19133812	Washer 13/32 x 2-3/8 x 12 Ga.

NOTE: All component dimensions give in U.S. inches
1 inch = 25.4 mm

TRACTOR -- MODEL NUMBER 917.253714

MOWER DECK

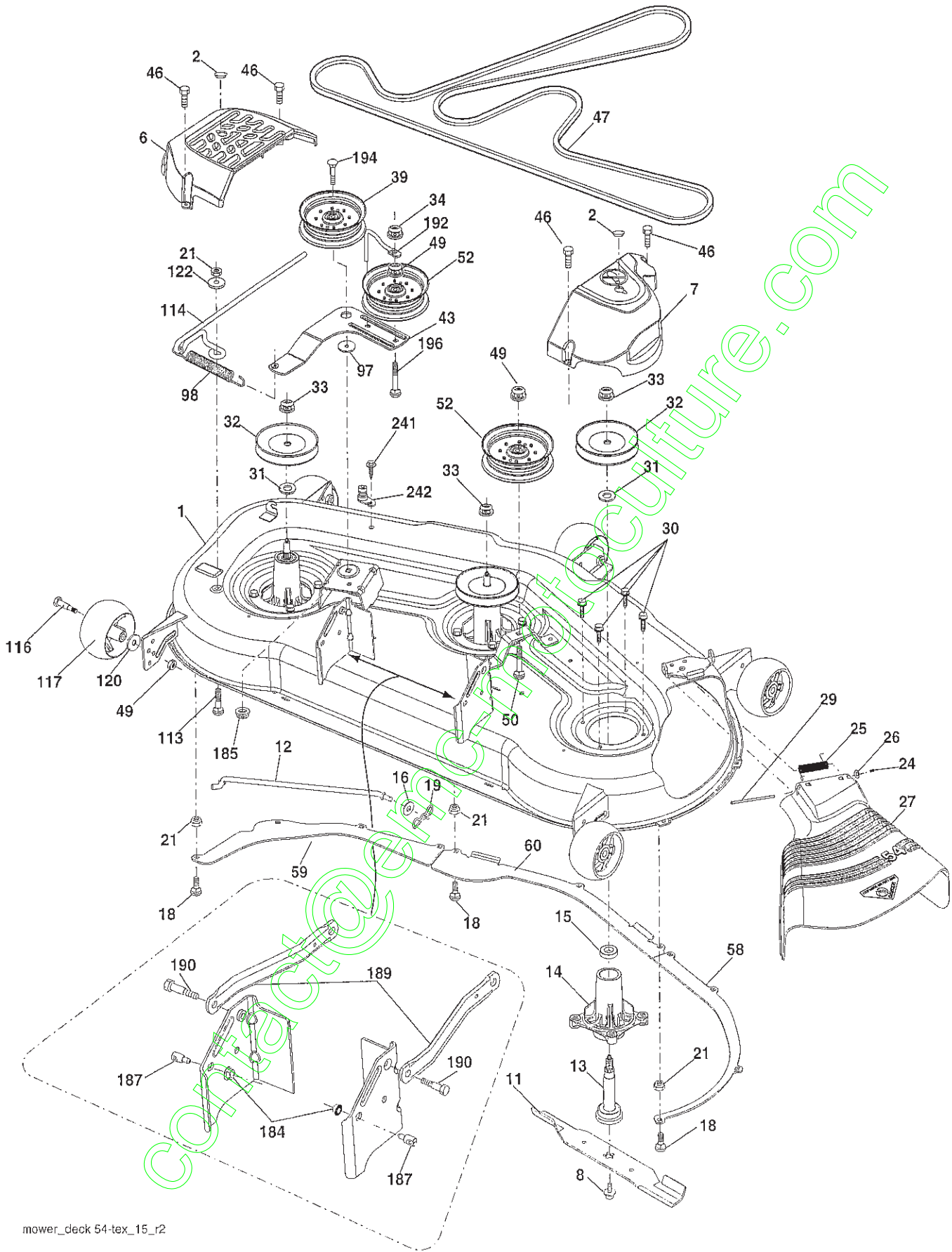

mower_deck 54-tex_15_r2

TRACTOR - - MODEL NUMBER 917.253714

MOWER DECK

KEY NO.	PART NO.	DESCRIPTION	KEY NO.	PART NO.	DESCRIPTION
1	195632X613	Deck Weldment Mower	60	187607	Baffle Center
2	178345	Plug Hole Mandrel	97	178515	Washer Hardened
6	196066	Cover Mandrel LH	98	196105	Spring Drive
7	197181	Cover Mandrel RH	113	72110508	Bolt RdHd Sqrk 5/16-18 x 3/4
8	193003	Bolt/Washer Asm. 7/16-20 unf	114	187556	Rod Tension Relief
11	187256	Blade Bagging	116	193406	Bolt, Shoulder
12	400337	Rod Anti Sway	117	174873	Gauge Wheel
13	187291	Shaft Asm. w/Lower Bearing	120	19132012	Washer 13/32 x 1-1/4 x 12 Ga.
14	187281	Housing, Mandrel	122	187557	Bushing Tension Relief
15	110485X	Bearing, Ball, Mandrel	184	73900500	Nut Lock Flange 5/16-18
16	19131312	Washer 13/32 x 13/16 x 12 Ga.	185	73900700	Nut Lock Flange 7/16-14 Gr. 5
18	72140505	Bolt RdHd 5/16-18 unc x 5/8	187	195161	Stud Fastener w/"D" Anti-Rotation
19	194208	Pin Cotter 5/16 Bow Tie Lock	189	195185	Arm Susp. Mower Rear
21	73680500	Nut, Crownlock 5/16-18 unc	190	196539	Bolt Shoulder
24	105304X	Cap Sleeve	192	198468	Keeper Belt Idler
25	178102	Spring, Torsion	194	74490736	Bolt Hex Washer Head
26	110452X	Nut, Push	196	72140620	Bolt RdHd 3/8-16 unc x 2-1/2 Gr. 5
27	187257X428	Deflector Shield	241	152927	Screw
29	131491	Rod, Hinge	242	415598	Washout Port
30	173984	Screw, Thdroll Washer Head	--	187292	Manderel Assembly (Includes Housing (Key #14), Shaft Assembly (Key #13) and Bearing Only (Key #15) and (Key #33) Pulley/Washer and Blade Bolt/Washers Not Included)
31	187690	Spacer Mandrel			
32	153535	Pulley, Mandrel			
33	400234	Nut, Flg. Top Lock			
34	73680600	Nut			
39	197380	Pulley, Idler			
43	196065	Arm, Idler	427610		Replacement Mower, Complete
46	137729	Screw Thd Roll 1/4-20 x 5/8			
47	196103	V-Belt, Mower			
49	73900600	Nut, Lock Flg. 3/8-16 unc			
50	72110616	Bolt, Carr. 3/8-16 x 2			
52	197379	Pulley Idler			
58	187342	Baffle Right			
59	187344	Baffle Left			

NOTE: All component dimensions given in U.S. inches
1 inch = 25.4 mm

contact@emc-moto.com

TRACTOR -- MODEL NUMBER 917.253714

LIFT ASSEMBLY

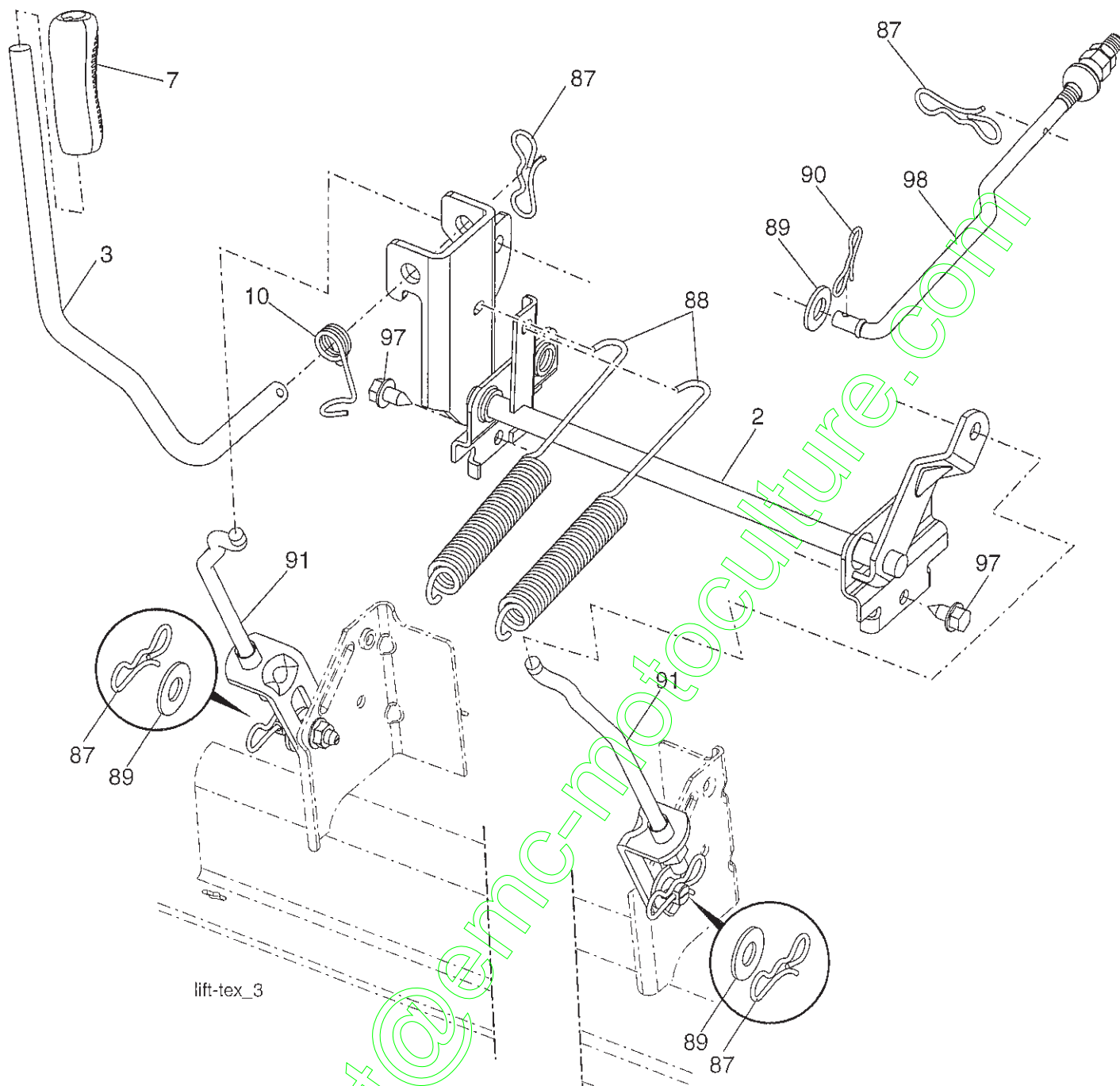

lift-tex_3

KEY NO.	PART NO.	DESCRIPTION
2	422027	Shaft Asm., Lift
3	195230	Lever Asm., Lift RH
7	445060X428	Grip, Lever
10	196314	Spring Torsion
87	194209	Pin Cotter 7/16 Bow Tie Lock
88	195304	Spring Lift Assist
89	19191912	Washer Clear Zinc
90	194208	Pin Cotter 5/16 Bow Tie Lock

KEY NO.	PART NO.	DESCRIPTION
91	403407	Link Lift Asm. Rear
97	17000612	Screw 3/8-16 x .75 R.Z.
98	195264	Link Asm. Susp. Front Mower

NOTE: All component dimensions give in U.S. inches
1 inch = 25.4 mm

TRACTOR - - MODEL NUMBER 917.253714

DECALS

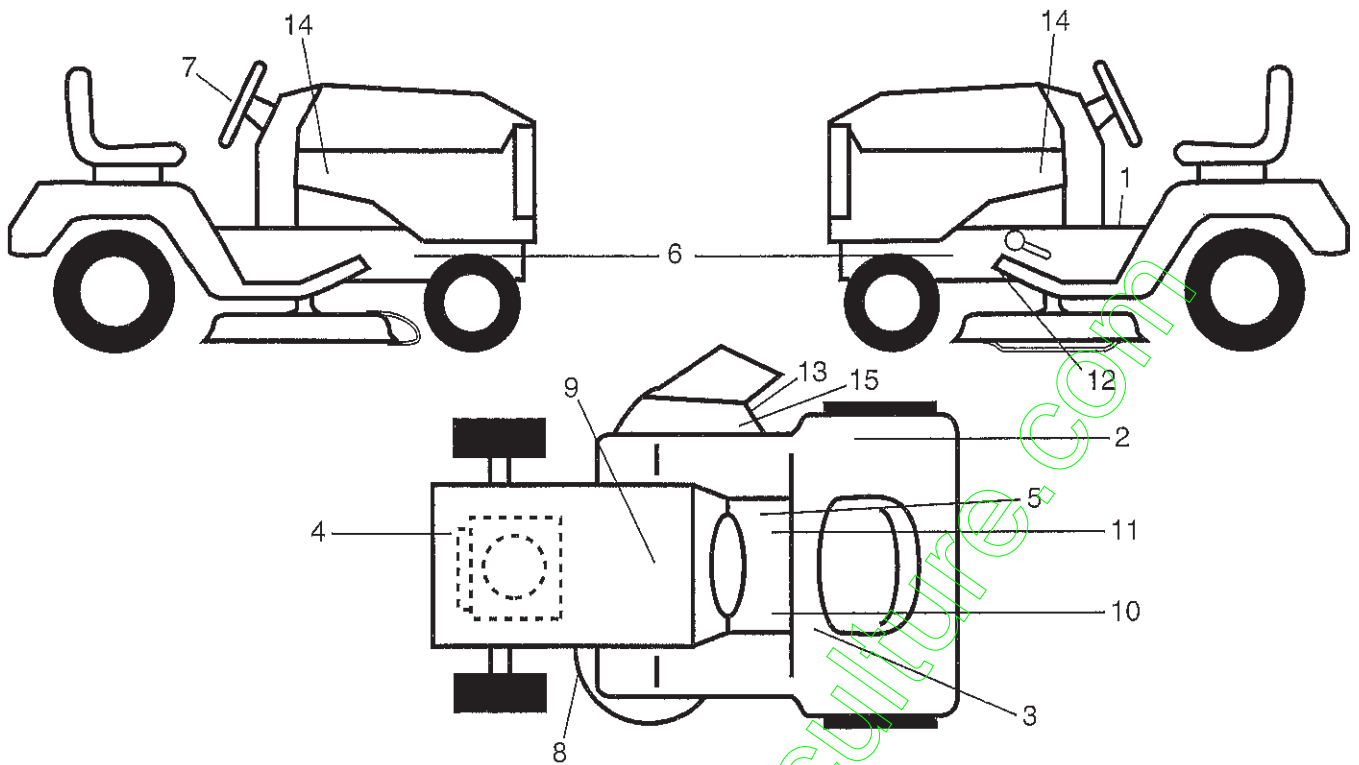

KEY NO.	PART NO.	DESCRIPTION	KEY NO.	PART NO.	DESCRIPTION
1	581578101	Decal, Oper./Warng	13	581579101	Decal, Cutfingr CE
2	581578201	Decal, Fender 105 DB/CE	14	443183	Decal, Hood RH/LH
3	581724201	Decal, Warn. Reserve Fuel	15	581579201	Decal, Deflector Wrn Cutfingr Symbol
4	581579701	Decal, Warning Engine Symbols	--	581724801	Decal Bypass
5	581578601	Decal, Operator Cruise Symbols	--	581724601	Decal Drawbar Load Limit
6	581579601	Decal, Chassis Hot Muffler	--	193279X428	Pad Footrest RH
7	439525	Decal, Steering	--	193101X428	Pad Footrest LH
8	581580002	Decal, Mower Schematic	--	581897540	Manual, Operator's (Euro)
9	145005	Decal, Battery Dnrg/Poi	--	581897550	Manual, Operator's (Scand)
10	581724001	Decal, Brake/Clutch Symbol	--	581897520	Manual, Operator's (E-Bloc)
11	581578001	Decal, Saddle Brake Parking	--	581897530	Manual, Operator's (Baltic)
12	421534	Decal, Mower V-Belt Schematic	--	581897526	Manual, Parts

WHEELS & TIRES

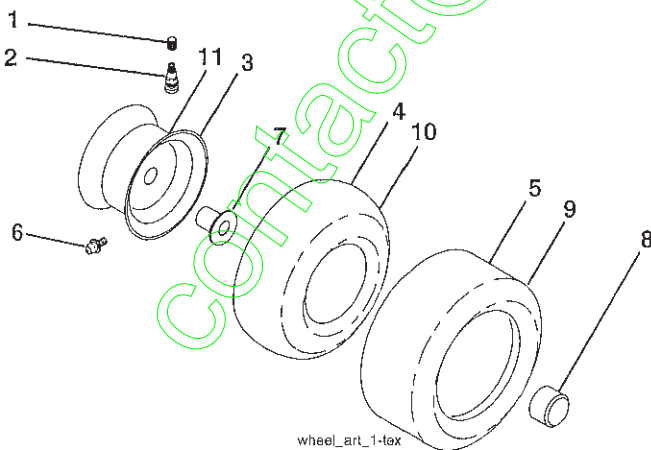

KEY NO.	PART NO.	DESCRIPTION
1	59192	Cap, Valve, Tire
2	65139	Stem, Valve
3	148736X613	Rim Assembly, Front
4	8134H	Tube, Front (Service Item Only)
5	106230X	Tire, Front
6	278H	Fitting, Grease (Front Wheel Only)
7	9040H	Bearing, Flange (Front Wheel Only)
8	104757X428	Cap, Axle
9	105588X	Tire, Rear
10	7154J	Tube, Rear (Service Item Only)
11	106277X613	Rim Assembly, Rear
--	144334	Sealant, Tire (10 oz. Tube)

NOTE: All component dimensions give in U.S. inches
1 inch = 25.4 mm

TRACTOR - - MODEL NUMBER 917.253714
HYDRO GEAR TRANSAXLE - - MODEL NUMBER G7-BCBB-1XDC-1FCA

G7-BCBB-1XDC-1FCA

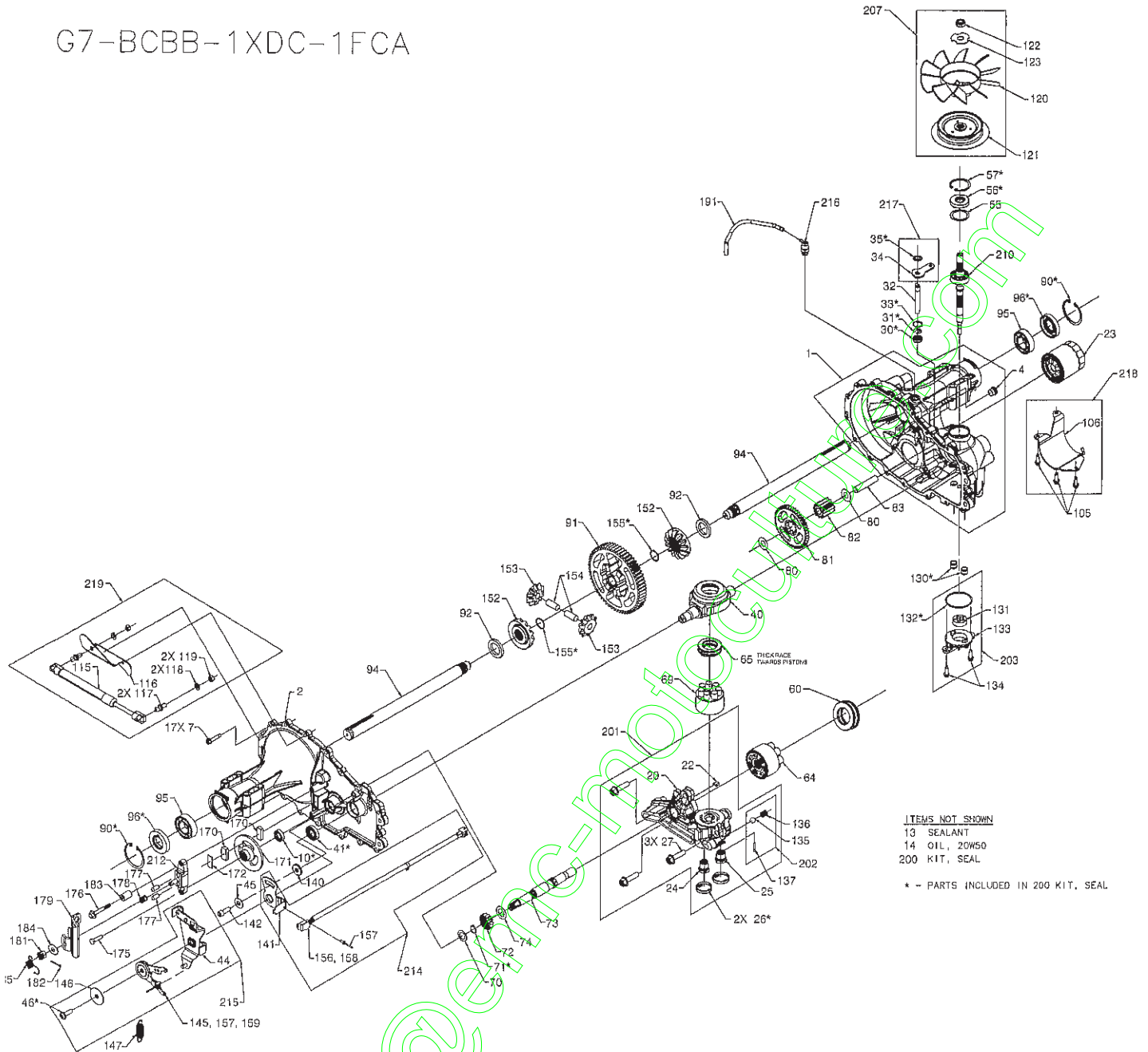

KEY NO.	PART NO.	DESCRIPTION
1	421183	Kit, Housing Main
(4)		Plug 9/16-18 (Metal)
		Housing, Main
		Pin, .25 X .375
		Bushing, .624 X .719 X .562
		Bushing, .865 X .985 X .790
		Bearing, Flange 1.0 X 1.376 X .99
2	421184	Kit, Housing, Side
		Housing, Side
		Bushing, .624 X .729 X .562
		Bushing, .865 X .985 .790
		Bearing, Flange 1.0 X 1.376 X .99
4	170434	Plug 9/16-18 (Metal)
7	170356	Hf hcs 1/4-20 X 1.25"
10	417764	Seal, Lip .625 X 1.0
13	178322	Tube, Sealant
14		Oil, 20w50

KEY NO.	PART NO.	DESCRIPTION
22	421185	Plate, Bypass
23	421186	Filter, Oil
26	421187	Seal, Plug 1.250 X .250
27	421188	Hf hcs 3/8-16 X 1.5 (Patch)
30	421189	Seal, Lip .375 X .75 X .25
31	421190	Ring, Retaining .375 External
32	421191	Rod, Bypass
33	421192	Ring, Retaining .750 Internal
35	421193	Retaining Ring
40	170354	Trunnion, Swashplate
41	170363	Seal, Lip 18 X 32 X 7
45	142884	Washer, .24 X .88 X .06
46	421194	Twhcs 5/16-24 X 1.00 (Patch)
55	170360	Washer, 1.23 X 1.56 X .04
56	170361	Seal, Lip 17 X 40 X 7
57	169870	Ring, Retaining 1.575 Internal
60	421195	Bearing, Thrust

TRACTOR - - MODEL NUMBER 917.253714

HYDRO GEAR TRANSAXLE - - MODEL NUMBER G7-BCBB-1XDC-1FCA

KEY NO.	PART NO.	DESCRIPTION	KEY NO.	PART NO.	DESCRIPTION
64	421196	Assembly, Block	(96)		Seal, Lip 25 X 52 X 10 Tc (Gray)
		Block	(130)		Tube, Connecting
		Spring	(132)		O-Ring, -137, .103 X 2.050
		Seat Washer	(155)		Ring, Spiral Ret .875
		Piston	201	421220	Kit, Center Section, Lh, Chrg
65	173159	Bearing, Thrust Ball 30 X 52 X 13	20		Center Section, Lh, Chrg
69	421197	Assembly, Block	(22)		Plate, Bypass
		Block	24		Check Plug
		Spring	25		Check Plug
		Seat Washer	(26)		Seal, Plug 1.250 X .250
		Piston	(27)		Hfhcs 3/8-16 X 1.5 (Patch) Brg, Jrnl
70	170404	Washer, .63 X 1.0 X .05	135		Ball, Steel 7/16"
71	170405	Ring, Retaining .625 External	136		Spring, Relief .42 X .75
72	421198	Gear, 14t	137		Pin, Spring .125 X .875
73	421199	Shaft, Motor	202	421221	Kit, Charge Relief
74	170433	Washer, .72 X 1.16 X .04	135		Ball Steel 7/16"
80	170418	Washer, .5 X 1.0 X .03	136		Spring, Relief .42 X .75
81	421200	Gear, 45t	137		Pin, Spring .125 X .875
82	421201	Gear, 11t	203	421222	Kit, Charge
83	170394	Pin, Jackshaft	(131)		Gerotor Assembly (1.9cc/Rev)
90	169539	Ring, Retaining 2.06 Internal	(132)		O-Ring 137 .103 X 2.050
91	421202	GEar, 60t	(133)		Cover, Charge Pump
92	421203	Spacer, 1.04 X 1.65 X .22	(134)		Screw, Hex Flange 1/4-20 X .75
94	421204	Shaft, Axle 1.00 X 14.48, Keyed	207	422128	Kit, Fan/Pulley
95	169535	Bearing, Ball 1.0 X 52 X 15	(120)		Fan Recess 7.0 (10 Blade)
96	161157	Seal, Lip 25 X 52 X 10 Tc (Gray)	(121)		Pulley 3.86 Inch
120	421205	Fan, Recess 7.0 (10 Blade)	(122)		Hex Lock Nut 1/2-20 (With Patch)
121	422126	Pulley 3.86 Inch	(123)		Washer, Slotted
122	150794	Hex Lock Nut 1/2-20 (With Patch)	210	421224	Kit, Input Shaft
123	199658	Washer, Slotted			Shaft, Input
130	421207	Tube, Connecting			Brg, Ball 17 X 40 X 12 OpeN 6203
131	169531	Gerotor Assembly (1.9cc/Rev)			Ring, Ret Wire .561 Id
132	421208	O-Ring, -137, .103 X 2.050	212	178329	Kit, Brake-Yoke
133	421209	Cover, Charge Pump			Bolt, Square Head
134	178343	Screw, Hex Flange 1/4-20 X .75			Brake-Yoke
140	421210	Spacer, .320 X 1.005 X .179	214	421225	Kit, G700 Ros
142	421211	Shcs 5/16-24 X 1 Patch	141		Assembly Rtn, Neutral
147	421212	Spring, Extention Rtn-44 Lbs	156		Retainer, Switch
152	421213	Gear, Bevel 14t Spline Id	157		Rivet, 5/32
153	421214	Gear, Bevel 10t	158		Switch, Rcs
154	421215	Pin, .499 X 1.20	215	421226	Kit, G700 Rtn/Ros
155	421216	Ring, Spiral Ret .875	44		Arm, Control
170	142883	Puck, Brake	(46)		Screw, 5/16-18 X 1
171	421217	Rotor, Brake	145		Assembly, Rtn
172	142882	Plate, Puck	146		Washer, .343 X 1.500 X .062
175	142892	Bolt, Hex Head 1/4-20 X 1 W/Patch	157		Rivet, 5/32
176	170410	Bolt, Hex Head 1/4-20 X 2 W/Patch	159		Clip, Actuator
177	170409	Pin, Brk .31 X .73 Plated	216	421227	Kit, Breather
178	170417	Spring, Comp Brake Anti-Drag			Fitting, 9/16 Sae
179	178330	Arm, Brake			Cap, Barbed Vent
181	170415	Nut, Castle 5/16-24 Pl	217	421228	Kit, Bypass
182	170416	Pin, Cotter 3/32 X 3/4	34		Bypass Arm
183	170411	Spacer, .26 X .57 X .87	(35)		Retaining Ring
184	142884	Washer, .27 X .88 X .12	218	421229	Kit, Filter Guard
185	178335	Spring, Brake Arm Bias	105		Hfhcs 1/4-20 X .75
191	421218	Tube .16 X .28 X 9.25	106		Guard, Filter, Lh
200	421219	Kit, Seal	219	422129	Kit, Damper
		Pin .25 X .375	115		Damper
(10)		Seal, Lip .625 X 1.0	116		Bracket
(26)		Seal, Plug 1.250 X .250	117		Stud, Threaded Ball
(30)		Seal, Lip .375 X .75 X .25	118		Washer, 5/16 Lock
(31)		Ring, Retaining .375 External	119		Nut, Hex 5/16-18
(33)		Ring, Retaining .750 Internal			
(35)		Ring, Retaining .375 External			
(41)		Seal, Lip 18 X 32 X 7			
(46)		TwHcs 5/16-24 X 1.00 (Patch)			
(56)		Seal, Lip 17 X 40 X 7			
(57)		Ring, Retaining 1.575 Internal			
(71)		Ring, Retaining .625 External			
(90)		Ring, Retaining 2.06 Internal			

*() * Indicates that part is listed elsewhere and is available as an individual part.

NOTE: All component dimensions given in U.S. inches
1 inch = 25.4 mm

TRACTOR - - MODEL NUMBER 917.253714

KOHLER ENGINE-MODEL NUMBER SV735, TYPE NUMBER 3019

BLOWER HOUSING & BAFFLES

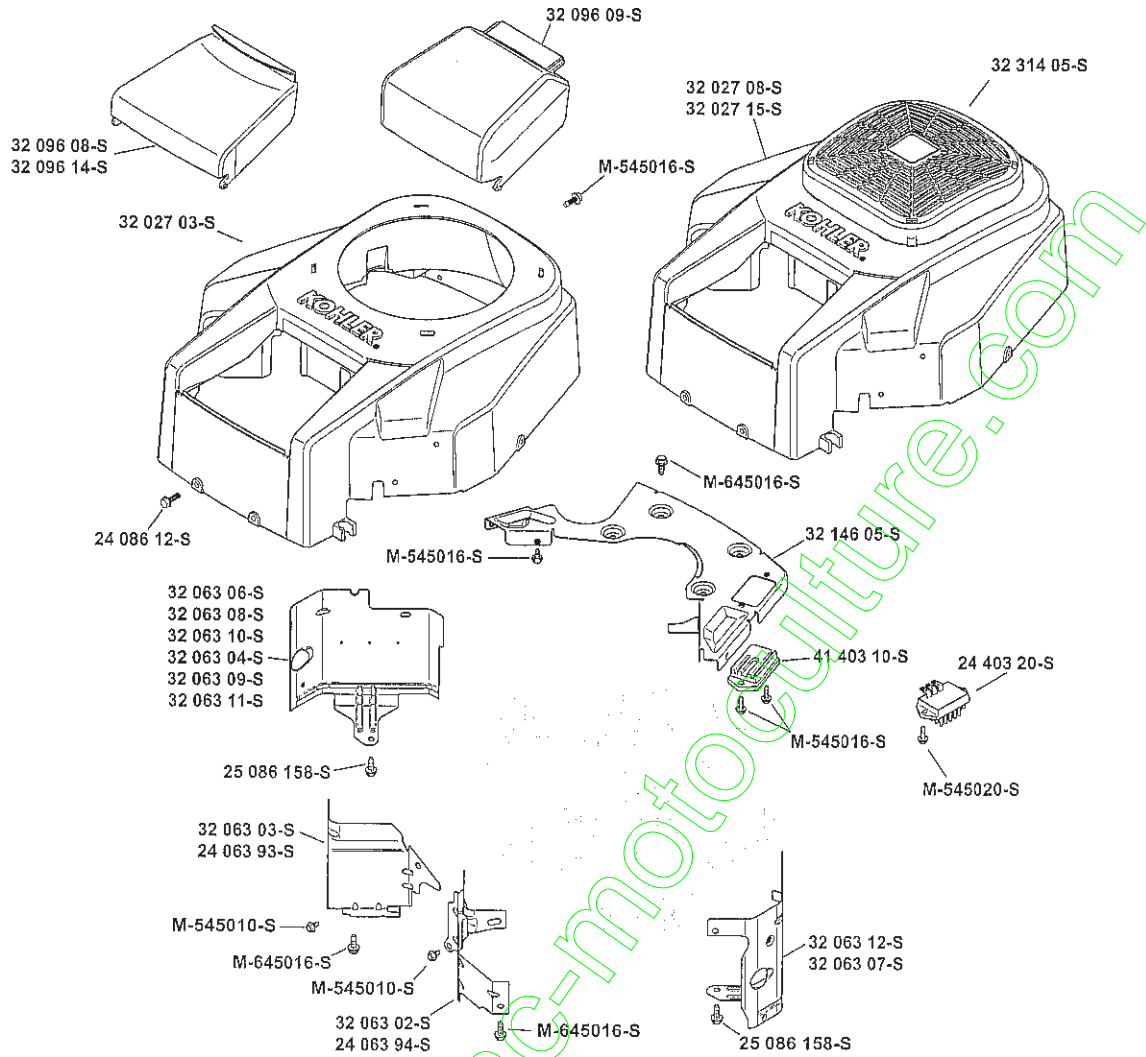

STARTING SYSTEM

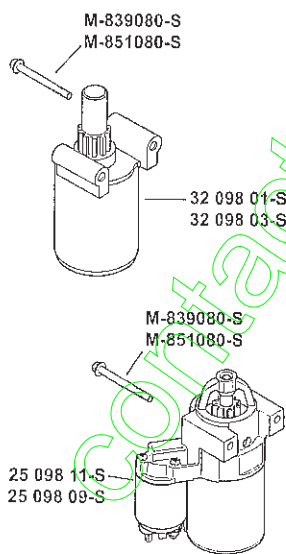

CRANKSHAFT

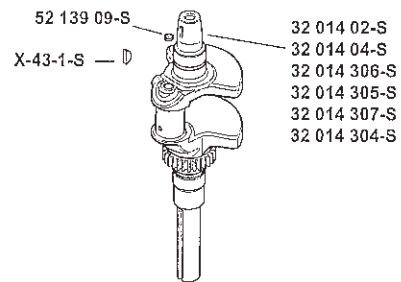

EXHAUST

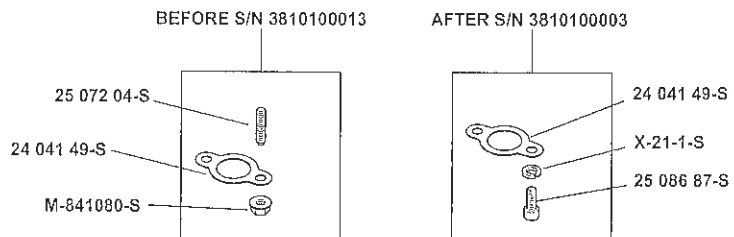

TRACTOR - - MODEL NUMBER 917.253714

KOHLER ENGINE-MODEL NUMBER SV735, TYPE NUMBER 3019

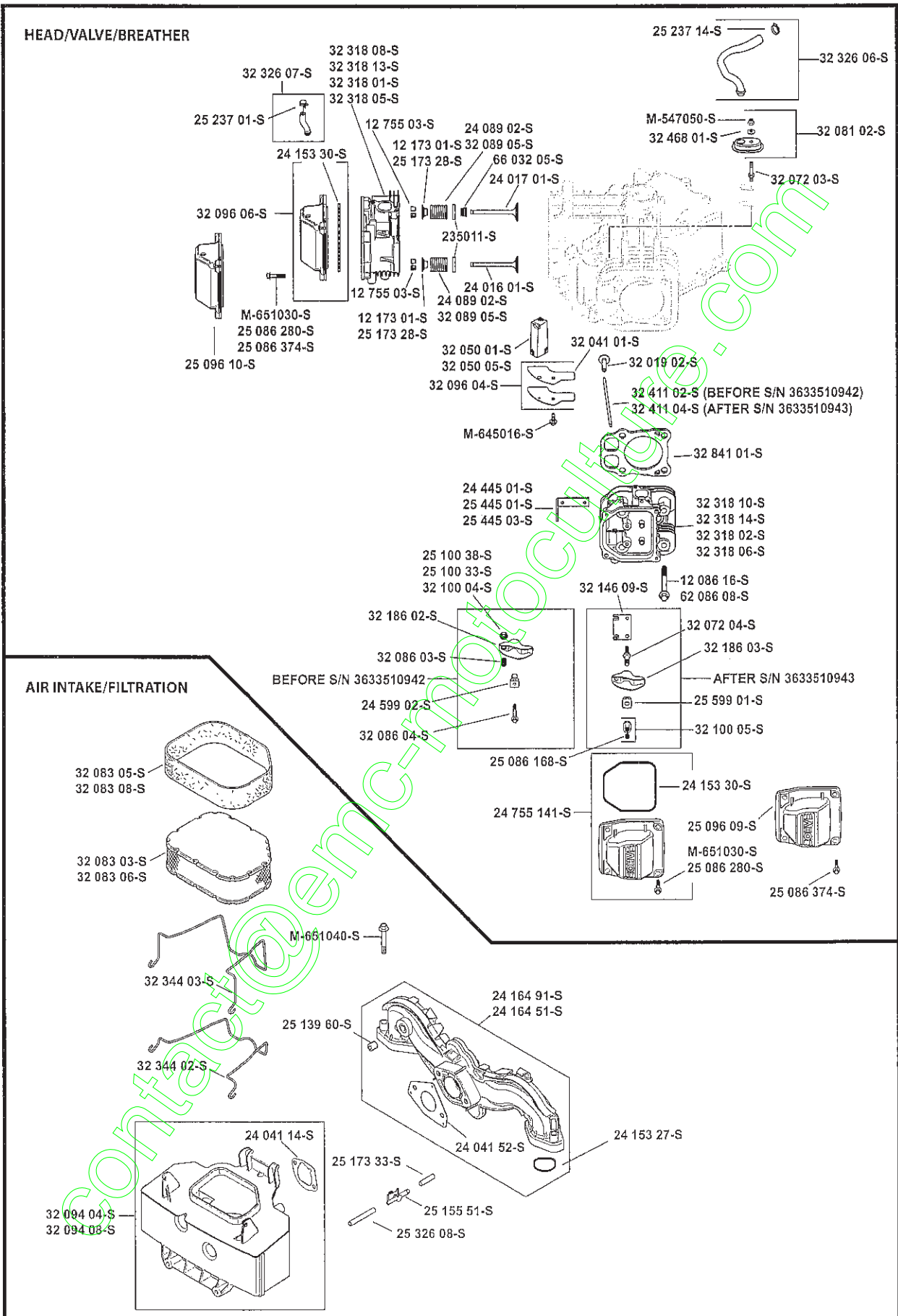

TRACTOR - - MODEL NUMBER 917.253714

KOHLER ENGINE-MODEL NUMBER SV735, TYPE NUMBER 3019

OIL PAN/LUBRICATION

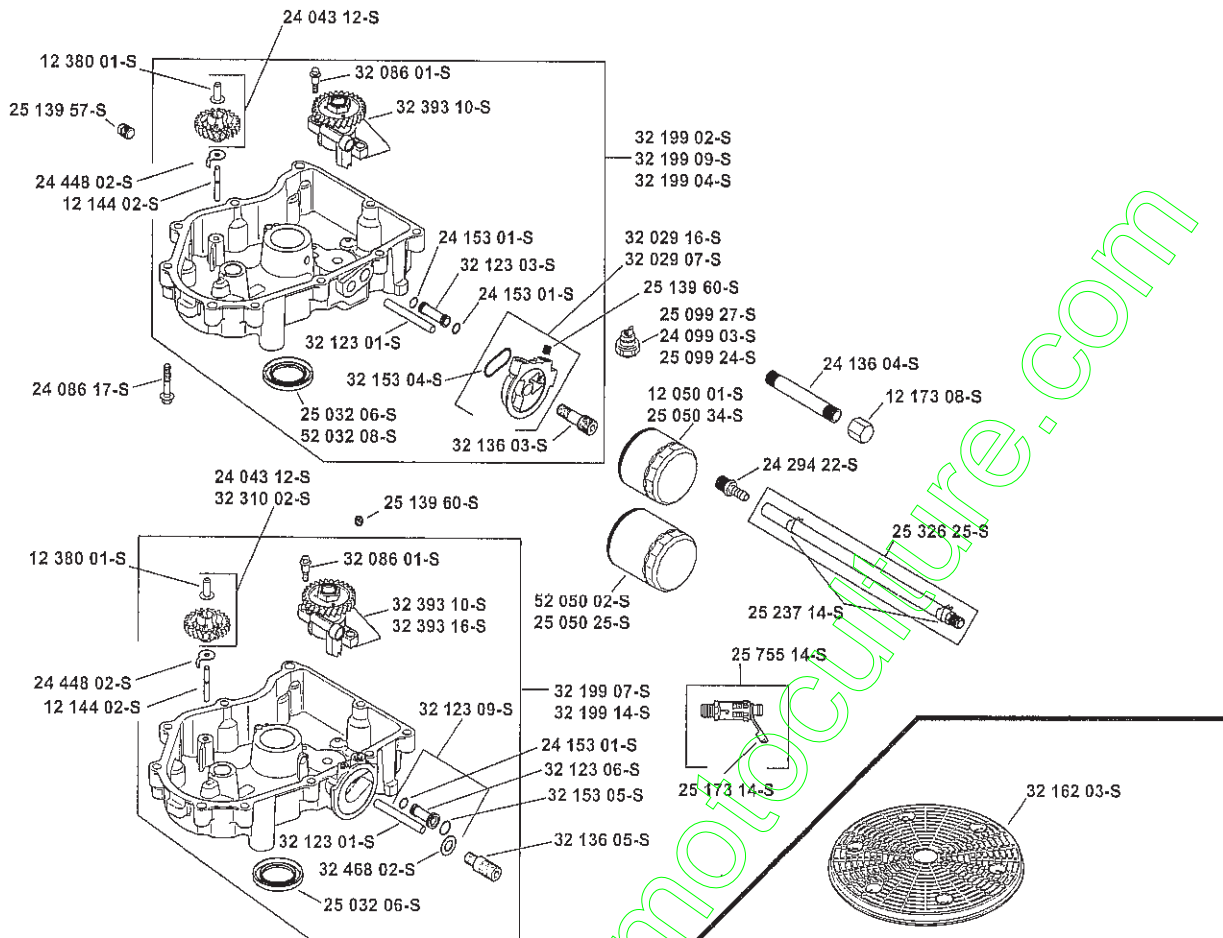

IGNITION/ELECTRICAL

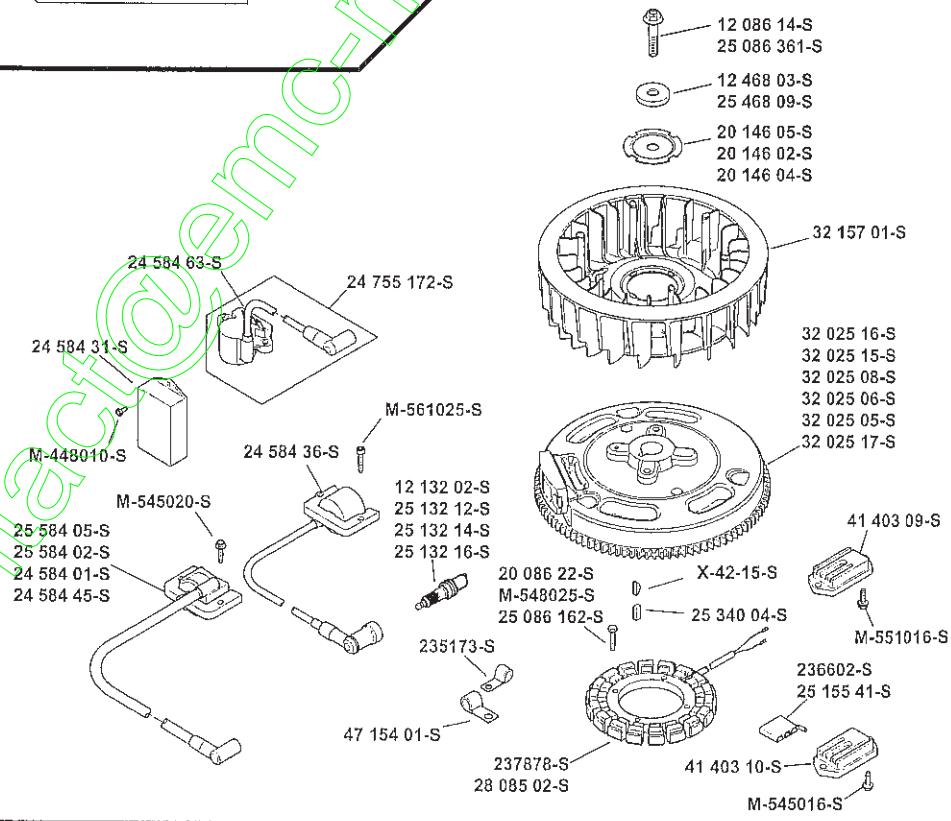

TRACTOR - - MODEL NUMBER 917.253714

KOHLER ENGINE-MODEL NUMBER SV735, TYPE NUMBER 3019

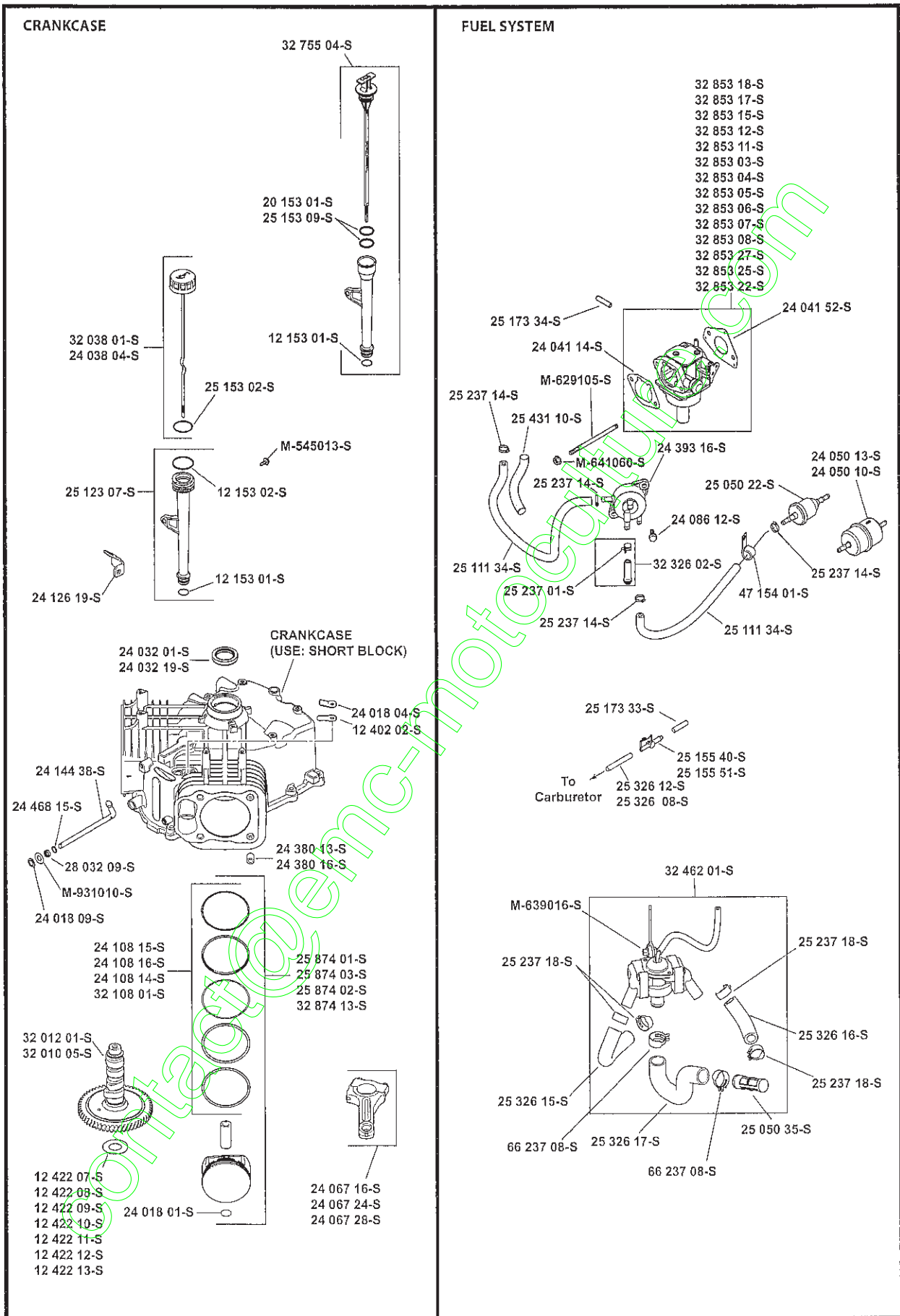

TRACTOR - - MODEL NUMBER 917.253714

KOHLER ENGINE-MODEL NUMBER SV735, TYPE NUMBER 3019

ENGINE CONTROLS

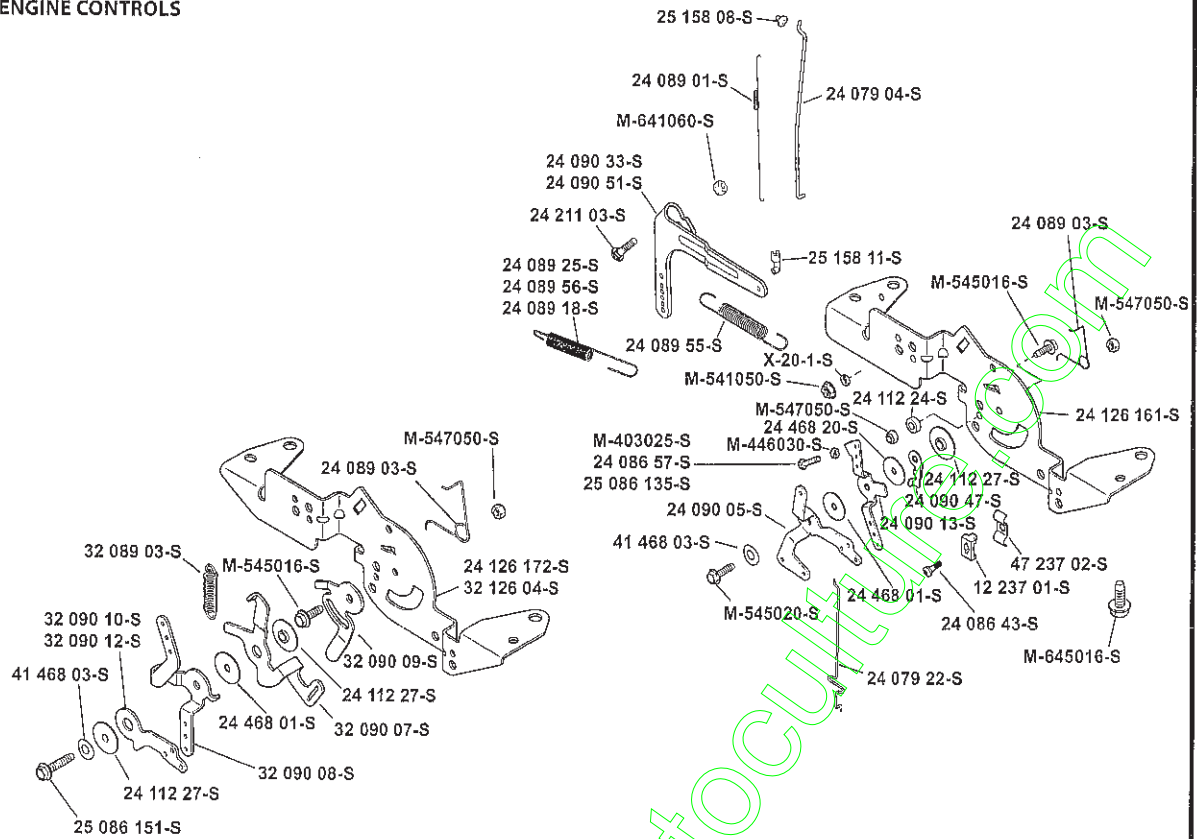

DECALS

- 32 113 06-S
- 32 113 07-S
- 32 113 08-S
- 32 113 09-S
- 32 113 12-S
- 32 113 13-S
- 32 113 14-S
- 32 113 16-S
- 32 113 17-S
- 32 113 18-S
- 32 113 19-S
- 32 113 21-S
- 32 113 22-S
- 32 113 24-S
- 32 113 25-S
- 32 113 26-S
- 32 113 27-S
- 32 113 28-S
- 32 113 29-S
- 32 113 35-S
- 32 113 36-S
- 32 113 37-S
- 32 113 38-S
- 32 113 39-S
- 32 113 42-S
- 32 113 43-S
- 32 113 44-S
- 32 113 46-S
- 32 113 48-S
- 32 113 49-S
- 32 113 50-S
- 32 113 54-S
- 32 113 57-S
- 32 113 58-S
- 32 113 64-S
- 32 113 61-S
- 32 113 62-S
- 32 113 63-S

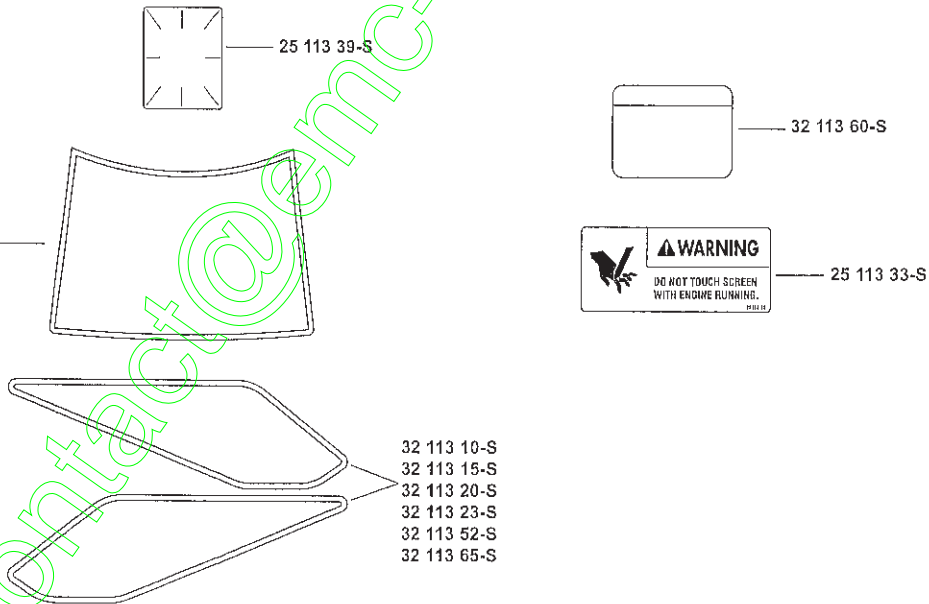

Artwork is representative.
Actual labels may differ depending on model and specification number.

TRACTOR - - MODEL NUMBER 917.253714

KOHLER ENGINE-MODEL NUMBER SV735, TYPE NUMBER 3019

PART NO.	DESCRIPTION	QTY	PART NO.	DESCRIPTION	QTY
AIR INTAKE/FILTRATION 10-32-4			ENGINE CONTROLS 9-32-4		
24 041 14-S	GASKET, AIR CLEANER BASE	1	24 211 03-S	BOLT, RD HD SQ NECK M6X1.0X25	1
32 344 02-S	LATCH, AIR CLEANER ELEMENT	1	24 090 51-S	LEVER, GOVERNOR	1
32 083 03-S	ELEMENT, AIR FILTER	1	M-641060-S	NUT, FLG M6X1.0	1
24 164 91-S	KIT, INTAKE MANIFOLD	1	24 089 01-S	SPRING, LINKAGE	1
M-651040-S	SCREW, FLG M6X1.0X40	4	25 158 08-S	BUSHING, LINKAGE RETAINING	1
25 139 60-S	PLUG, CTSK PIPE 1/8"	1	24 079 04-S	LINKAGE, THROTTLE	1
24 041 52-S	GASKET, CARBURETOR	1	25 158 11-S	BUSHING, THROTTLE LINKAGE	1
24 153 27-S	O-RING, INTAKE PORT	2	M-545016-S	SCREW, FLG THD FRM M5X0.8X16	1
32 094 08-S	BASE, AIR CLEANER	1	M-547050-S	NUT, LOCK M5X 8	2
25 326 08-S	HOSE, EVAPORATIVE, 20"	1	24 089 03-S	SPRING, CHOKE RETURN	1
25 173 33-S	CAP, MASKING	1	32 126 04-S	BRACKET, CONTROL	1
25 155 51-S	CONNECTOR, EVAPORATIVE	1	M-645016-S	SCREW, FLG THD FRM M6X1.0X16	4
BLOWER HOUSING & BAFFLES 6-32-1			12 237 01-S	CLAMP, CABLE	2
32 027 03-S	KIT, HOUSING BLOWER (41 037 10-S)	1	24 086 43-S	SCREW, LBD THD FRM M5x0.8x16	2
32 096 08-S	COVER, AIR CLEANER	1	24 079 22-S	LINKAGE, CHOKE	1
M-545016-S	SCREW, FLG THD FRM M5X0.8X16	6	24 111 2 27-S	SPACER, CONTROL ASSEMBLY	1
M-645016-S	SCREW, FLG THD FRM M6X1.0X16	8	24 090 47-S	LEVER, THROTTLE ACTUATOR	1
32 146 05-S	KIT, BACKING PLATE	1	24 090 13-S	LEVER, THROTTLE CONTROL	1
32 063 12-S	BAFFLE, CYL BARREL - #2 SIDE	1	24 468 01-S	WASHER, FLAT 5.5 MM	1
24 063 94-S	BAFFLE, VALLEY #2 CYLINDER	1	M-545020-S	SCREW, FLG THD! FRM M5X.8X20	1
M-545010-S	SCREW, FLG THD FRM M5X.8X10	2	41 468 03-S	WASHER, SPRING 1/4"	1
24 063 93-S	BAFFLE, VALLEY #1 CYLINDER	1	24 090 05-S	LEVER, CHOKE	1
32 063 10-S	BAFFLE, CYL BARREL - #1 SIDE	1	25 086 135-S	SCREW, HEX HD CAP (W/LOCTITE)	1
24 086 12-S	SCREW, TAP M6X1.7X18	2	24 468 20-S	WASHER, FLAT 5 MM	1
25 086 158-S	SCREW, FLNG THD FRM M6X1.0 X10	2	24 112 24-S	SPACER	1
NOT ILLUSTRATED			CRANKCASE GROUP 2-32-5		
41 403 10-S	REGULATOR/RECTIFIER	1	12 402 02-S	REED, BREATHER	1
41 037 10-S	NAMEPLATE, SERVICE	1	24 018 04-S	REI TAINER, BREATHER REED	1
NOT ILLUSTRATED			24 380 16-S	PIN, LOCATING	6
FUEL SYSTEM GROUP 8-32-35			24 032 19-S	SEAL, OIL (HELIX LIP)	1
32 853 25-S	KIT, CARBURETOR	1	12 422 07-S	SHIM, CAMSHAFT (WHITE .028")	1
M-629105-S	STUD, M6X1.0X106 USE 25 072 25-S	1	12 422 08-S	SHIM, CAMSHAFT (BLUE .03")	1
M-641060-S	NUT, FLG M6X1.0	2	12 422 09-S	SHIM, CAMSHAFT (RED .032")	1
47 154 01-S	CLIP, CABLE	1	12 422 10-S	SHIM, CAMSHAFT (YELLOW .034")	1
24 086 12-S	SCREW, TAP M6X1 7X18	2	12 422 11-S	SHIM, CAMSHAFT (GREEN .036")	1
24 393 16-S	PUMP, FUEL	1	12 422 12-S	SHIM, CAMSHAFT (GRAY .038")	1
25 11 11 34-S	LINE, FUEL (24" CUT TO LENGTH)	1	12 422 13-S	SHIM, CAMSHAFT (BLACK .04")	1
25 237 14-S	CLAMP, HOSE 1/2" USE 25 237 31-S	2	24 018 01-S	RETAINER, PISTON PIN	1
24 050 13-S	FILTER, FUEL	1	24 067 28-S	ROD, ASSEMBLY CONNECTING (STD)	1
24 041 14-S	GASKET, AIR CLEANER BASE	1	24 018 09-S	RETAINER, RING	1
24 041 52-S	GASKET, CARBURETOR	1	24 468 15-S	WASHER, FLAT 11/32"	1
CRANKSHAFT 1-32-5			28 032 09-S	SEAL, GOVERNOR CROSS SHAFT	1
52 139 09-S	PLUG, CUP	1	24 144 38-S	SHAFT, GOVERNOR CROSS	1
32 014 304-S	CRANKSHAFT	1	24 126 19-S	BRACKET, OIL FILL TUBE	1
X-43-1-S	KEY, 1/8" X 1/2"	1	M-545013-S	SCREW, FLG THD FRM M5X0.8X13	1
			M-931010-S	WASHER, FLAT 9 MM	1
				< /td>	
			32 755 04-S	KIT, DIPSTICK AND TUBE	1
			25 153 09-S	O-RING	2
			12 153 01-S	O-RING, LOWER OIL FILL TUBE	1
			32 010 05-S	CAMSHAFT ASSEMBLY	1
			32 874 13-S	KIT, PISTON W/RING (STD)	1
			32 108 01-S	RING SET, PISTON (STD)	1

TRACTOR - - MODEL NUMBER 917.253714

KOHLER ENGINE-MODEL NUMBER SV735, TYPE NUMBER 3019

PART NO.	DESCRIPTION	QTY	PART NO.	DESCRIPTION	QTY
HEAD/VALVE/BREATHER 4-32-4					
12 755 03-S	KIT, RETAINER	4	25 132 14-S	SPARK PLUG, RFI	2
235011-S	RETAINER, SPRING	4	237878-S	KIT, 15 / 20 AMP STATOR	1
66 032 05-S	SEAL, VALVE STEM	2	M-548025-S	SCREW, THD FRM M5X0.8X25	2
24 016 01-S	VALVE, EXHAUST (STD)	2	25 086 361-S	SCREW, HEX FLANGE	1
24 017 01-S	VALVE, INTAKE (STD)	2	25 340 04-S	KEY, SQUARE	1
32 326 06-S	KIT, BREATHER HOSE (INCLUDES 25 237 14-S)	1	25 468 09-S	WASHER, FLAT	1
25 237 14-S	CLAMP, HOSE 1/2" USE 25 237 31-S	5	32 025 15-S	FLYWHEEL ASSEMBLY (SV735/740)	1
32 081 02-S	KIT, BREATHER HOUSING (INCLUDES M-547050-S, 32 468 01-S)	1	20 146 05-S	PLATE, FAN MOUNTING	1
M-547050-S	NUT, LOCK M5X.8	1	32 157 01-S	FAN	1
32 468 01-S	WASHER, SEALING	1	32 162 03-S	SCREEN, GRASS	1
32 072 03-S	STUD, BREATHER COVER	1	24 584 63-S	MODULE, SPARK ADV (DSAI) ASS! Y2	1
32 019 02-S	TAPPET	4	M-545020-S	SCREW, FLG THD FRM M5X.8X20	4
32 841 01-S	KIT, CYLINDER HEAD GASKET	2	25 155 41-S	CONNECTOR	1
62 086 08-S	SCREW, FLG M10X1.5X90	8	25 454 05-S	TIE	1
M-645016-S	SCREW, FLG THD FRM M6X1.0X16	1	NOT ILLUSTRATED		
32 096 04-S	COVER, BREATHER (INCLUDES 32 041 01-S)	1	32 176 17-S	KIT, HARNESS, WIRING	1
32 318 13-S	KIT, #1 CYLINDER HEAD ASSEMBLY 1 (includes EXHAUST MOUNTING HARDWARE)(AFTER S/N 3810100003)	1	NOT ILLUSTRATED		
32 318 14-S	KIT, #2 CYLINDER HEAD ASSEMBLY 1 (INCLUDES EXHAUST MOUNTING HARDWARE) (AFTER S/N 38101 00003)	1	47 154 01-S	CLIP, CABLE	1
32 146 09-S	PLATE, GUIDE	2	EXHAUST 11-32-2		
32 072 04-S	STUD, ROCKER (after S/N 3633510943)	4	24 041 49-S	GASKET, EXHAUST	2
32 186 03-S	ARM, ROCKER	4	25 454 05-S	TIE	1
32 100 05-S	HEX NUT ASSEMBLY (INCLUDES 25 086 168-S) (AFTER S/N 3633510943)	4	NOT ILLUSTRATED		
25 599 01-S	PIVOT, ROCKER ARM (after S/N 3633510943)	4	LUBRICATION GROUP 3-32-24		
32 411 04-S	ROD, PUSH (after S/N 3633510943)	4	24 086 17-S	SCREW, FLG M8X1.25X45	10
32 755 03-S	KIT, CYLINDER HEAD HARDWARE	2	25 032 06-S	SEAL, OIL	1 < /tr>
NOT ILLUSTRATED			25 139 57-S	PLUG, SQ HD PIPE 3/8"	2
(Services 1 Head. Quantities listed are for both heads)(12 755 03-S, 12 173 01-S, 24 089 02-S, 235011-S, 66 032 05-S, 24 017 01-S, 24 016 01-S, 32 146 09-S, 32 072 04-S, 32 186 03-S, 32 100 05-S, 25 086 168-S, 25 599 01-S, 32 411 04-S)			32 199 14-S	OIL PAN ASSEMBLY	1
32 326 07-S	KIT, FUEL PUMP HOSE	1	12 144 02-S	SHAFT, GOVERNOR GEAR	1
32 050 05-S	FILTER, BREATHER	1	24 448 02-S	TAB, LOCKING	1
32 089 05-S	SPRING, VALVE	4	32 31 10 02-S	KIT, GOVERNOR GEAR	1
25 086 374-S	SCREW, FAN HEAD	8	24 153 01-S	O-RING, OIL PICK-UP	1
25 237 01-S	CLAMP, HOSE	1	32 086 01-S	SCREW, SHD THD FRM M6X.0X6.5	2
25 096 10-S	COVER, ROCKER STAMPED STEEL	1	32 393 16-S	PUMP, OIL ASSEMBLY	1
25 096 09-S	COVER, ROCKER STAMPED STEEL	1	52 050 02-S	FILTER, OIL	1
32 050 05-S	FILTER, BREATHER	1	32 123 01-S	TUBE, OIL FEED - FILTER TO PAN	1
25 173 28-S	CAP, VALVE SPRING	2	32 123 09-S	OIL FEED TUBE ASSEMBLY	1
25 445 03-S	STRAP, LIFT	1	32 136 05-S	NIPPLE, OIL FILTER	1
			25 139 60-S	PLUG, CTSK PIPE 1/8"	1
			32 468 02-S	WASHER, FLAT	1
			12 380 01-S	PIN, GOVERNOR REGULATING	1
			32 123 06-S	TUBE, OIL FEED	1
			32 153 05-S	O-RING	1
			STARTING SYSTEM 7-32-4		
			M-851080-S	SCREW, FLG M8X1.25X80	2
			32 098 03-S	STARTER ASSEMBLY	1
			DECALS 12-32-21		
			25 113 39-S	DECAL, CLEAR LAMINATE	1
			32 113 23-S	DECAL, SEAR! S 2PC WNG ST	1
			32 113 27-S	DECAL, 26 HP	1

IGNITION/CHARGING GROUP 5-32-53

LIMITED WARRANTY ON CRAFTSMAN RIDING EQUIPMENT

For two (2) years from the date of purchase, if this Craftsman Riding Equipment is maintained, lubricated and tuned up according to the instructions in the owner's manual, Sears will repair or replace free of charge any parts that are found to be defective in material or workmanship according to the guidelines of coverage listed below. Sears will also provide free labor for these applicable warranted parts for the two full years. During the first 30 days of purchase, there will be no charges to service the product at your home for issues covered by this warranty. (See exclusions below). For your convenience, IN HOME warranty service will still be available after the first 30 days of purchase, but a trip charge will apply. This charge will be waived if the Craftsman product is dropped off at an authorized Sears location. For the nearest authorized Sears location, please call 1-800-4-MY-HOME®. This warranty applies only while this product is within the United States.

This Warranty does not cover:

- Expendable items which become worn during normal use, including but not limited to blades, spark plugs, air cleaners, belts, and oil filters.
- Standard Maintenance Servicing, oil changes, or tune-ups
- Tire replacement or repair caused by punctures from outside objects, such as nails, thorns, stumps, or glass.
- Repairs necessary because of operator abuse, including but not limited to, damage caused by towing objects beyond the capability of the riding equipment, impacting objects that bend the frame or crankshaft, or over-speeding the engine.
- Repairs necessary because of operator negligence, including but not limited to, electrical and mechanical damage caused by improper storage, failure to use the proper grade and amount of engine oil, failure to keep the deck clear of flammable debris, or failure to maintain the equipment according to the instructions contained in the owner's manual.
- Engine (fuel system) cleaning or repairs caused by fuel determined to be contaminated or oxidized (stale). In general, fuel should be used within 30 days of its purchase date.
- Normal deterioration and wear of the exterior finishes, or product label replacement.
- Riding equipment used for commercial or rental purposes.

LIMITED WARRANTY ON BATTERY

For ninety (90) days from date of purchase, if any battery included with this riding equipment proves defective in material or workmanship and our testing determines the battery will not hold a charge, Sears will replace the battery at no charge. During the first 30 days of purchase, there will be no charges to replace the battery at your HOME. After the first 30 days, for your convenience, IN-HOME warranty service will still be available but a trip charge will apply. This charge will be waived if the Craftsman product is dropped off at an authorized Sears location. For the nearest authorized Sears location, please call 1-800-4-MY-HOME®.

This battery warranty applies only while this product is within the United States.

This warranty gives you specific legal rights, and you may also have other rights, which vary, from state to state.

Sears Brands Management Corporation, Dept.817WA, Hoffman Estates, IL 60179

contact@enc-motoculture.com

