

REPAIR PARTS MANUAL
MODEL NO. 917.259441
Lawn Tractor

CRAFTSMAN®

HOW TO USE THIS MANUAL

This manual is designed to provide the customer with a means to identify the parts on his/her tractor when ordering repair parts. The illustrations may or may not represent the actual assemblies; therefore, it is not recommended to use this manual as a guide to assemble or disassemble the tractor. Some hardware and parts are drawn larger in order to more readily identify them.

Each tractor has its own model number.

The model number for your tractor can be found on the fender under the seat.

When ordering parts, always give the following information:

- Product - "Tractor"
- Model Number - "917.259441"
- Part Number
- Part Description

TABLE OF CONTENTS

SCHEMATIC.....	3
ELECTRICAL.....	4-5
CHASSIS.....	6-7
DRIVE.....	8-9
STEERING.....	10-11
SEAT.....	12
DECALS.....	13
ENGINE.....	14-15
MOWER LIFT.....	16-17
MOWER DECK.....	18-19
BAGGER.....	20-21
TRANSAXLE.....	22-23
ENGINE BREAKDOWN.....	24-28

REPAIR PARTS

TRACTOR- -MODEL NO. 917.259441

SCHEMATIC

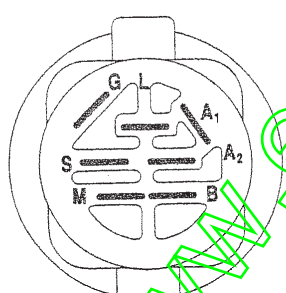
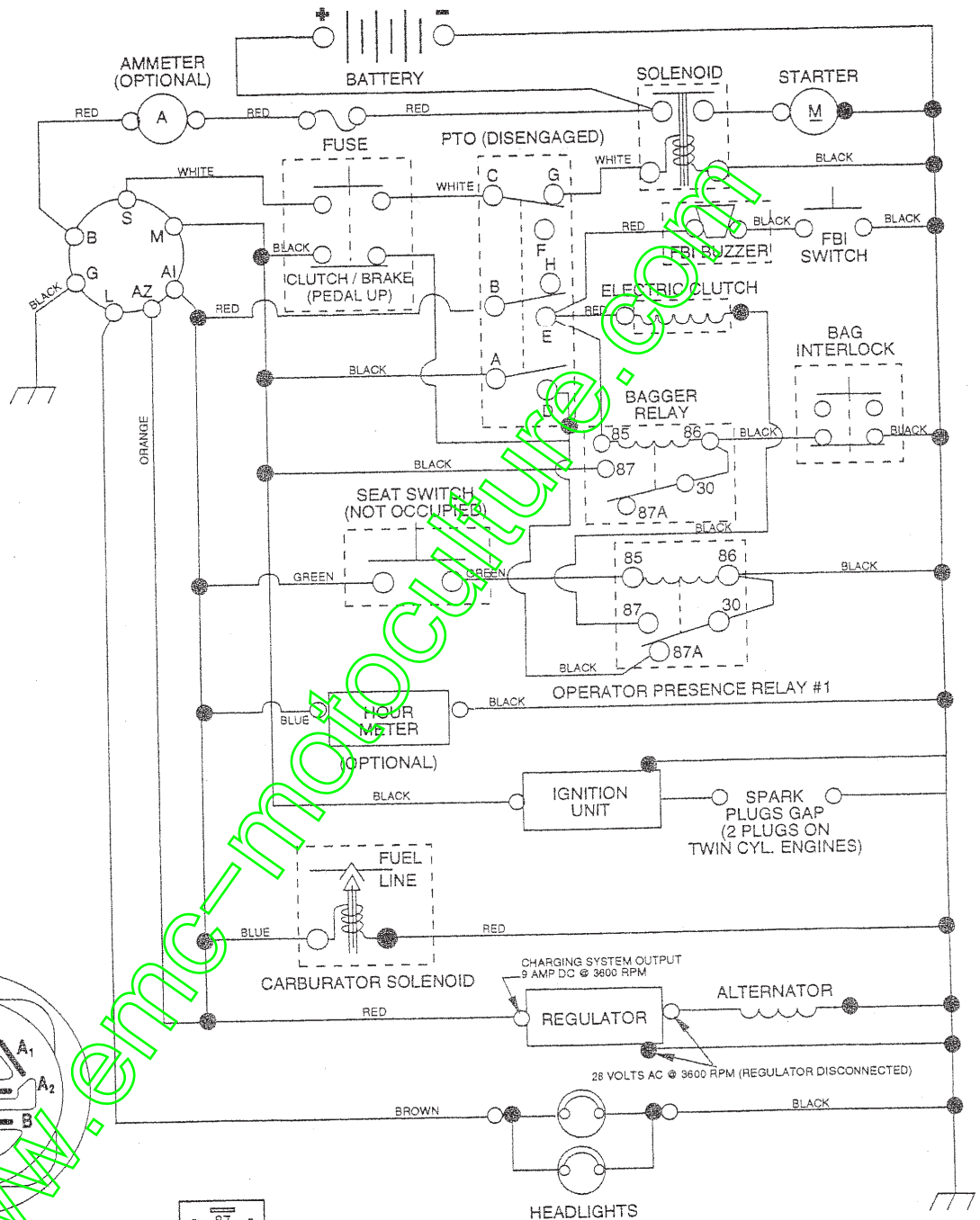

IGNITION SWITCH

POSITION	CIRCUIT	"MAKE"
OFF	M-G+A1	NONE
RUN/LIGHT	B+A1	A2+L
RUN	B+A1	NONE
START	B+S+A1	NONE

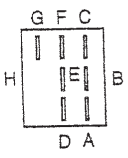
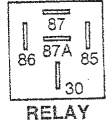

POSITION	CIRCUIT
OFF	C+G, B+H
ON	C+F, B+E, A+D

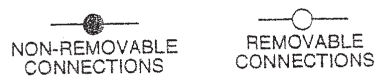

WIRING INSULATED CLIPS
 NOTE: IF WIRING INSULATED CLIPS WERE REMOVED FOR SERVICING OF UNIT, THEY SHOULD BE REPLACED TO PROPERLY SECURE YOUR WIRING.

REPAIR PARTS

TRACTOR- -MODEL NO. 917.259441

ELECTRICAL

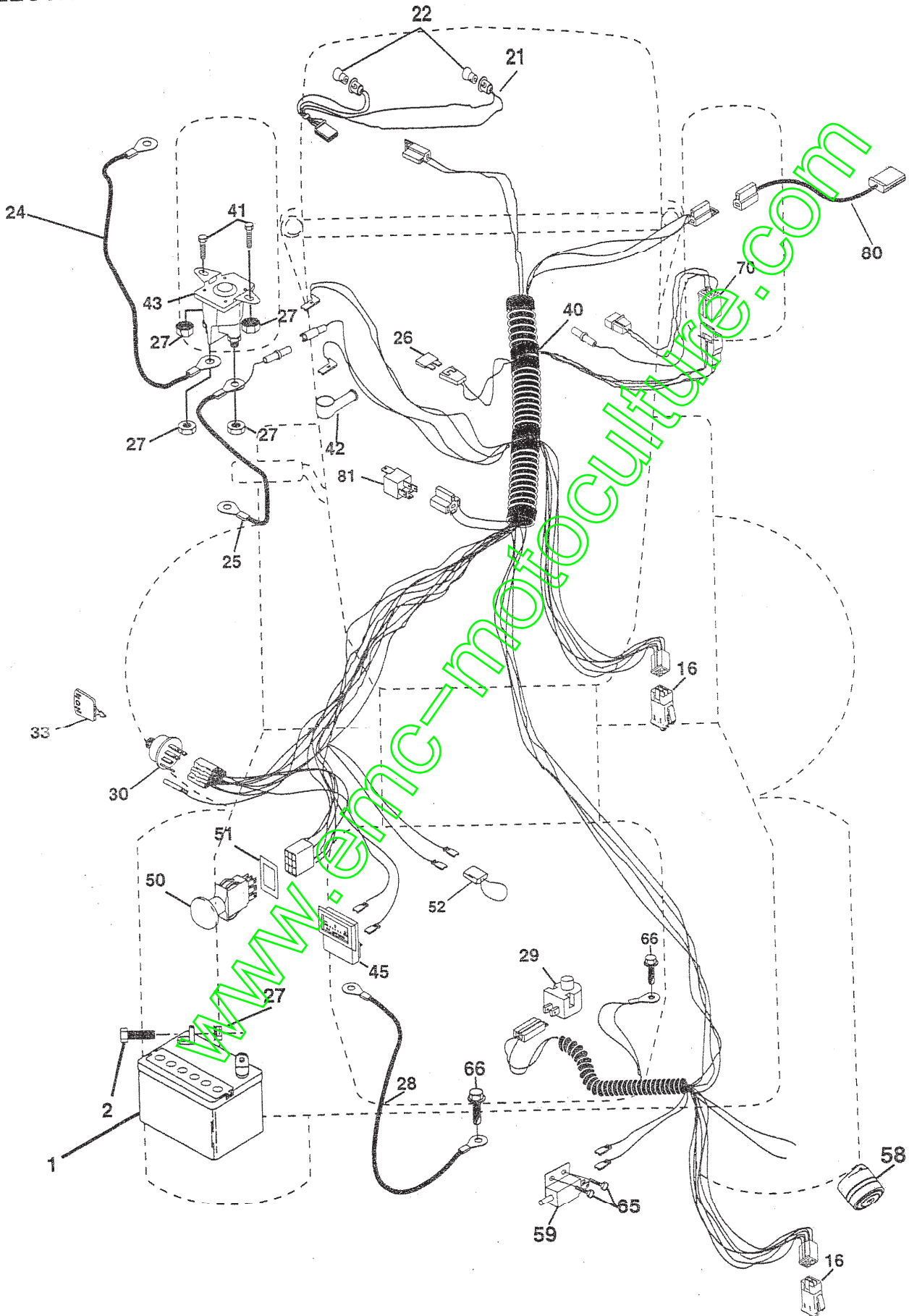

REPAIR PARTS

TRACTOR- -MODEL NO. 917.259441

ELECTRICAL

KEY NO.	PART NO.	DESCRIPTION
1	144925	Battery
2	74760412	Bolt Hex Hd 1/4-20 Unc X 3/4
16	153664	Switch Interlock Push-In
21	166182	Harness Asm Light W/4152J
22	4152J	Bulb Light #1156
24	4799J	Cable Starter 6Ga 11" Red
25	165987	Cable Battery Crd 56" Red
26	166180	Fuse 15 Amp
27	STD541425	Nut Keps Hex 1/4-20 Unc
28	127725X	Cable Ground 6Ga 18" Black
29	160784	Switch Plunger Normal Op Olive
30	163968	Switch Ignition
33	109310X	Key Ign Molded 140403
40	170214	Harness Ign Crd Elect
41	71110408	Bolt Flk Fin Hex 1/4-20 Unc X 1/2
42	131563	Cover Terminal Red
43	145673	Solenoid
45	122822X	Ammeter Rectangular 15 amp
50	169416	Switch PTO
51	140405	Ring Retainer PTO
52	141940	Protection Wire Loop
58	169419	Buzzer Crd
59	166299	Switch FBI CRD
65	STD611005	Screw Slftp #10-16 x 1/2 Ty-Ab
66	17490608	Screw Thdrol 3/8-16 x 1/2 Ty-Tt
70	170247	Harness Engine
80	166182	Harness Clutch EVX 146635
81	109748X	Relay Asm

NOTE: All component dimensions given in U.S. inches.
1 inch = 25.4 mm.

REPAIR PARTS

TRACTOR- -MODEL NO. 917.259441

CHASSIS AND ENCLOSURES

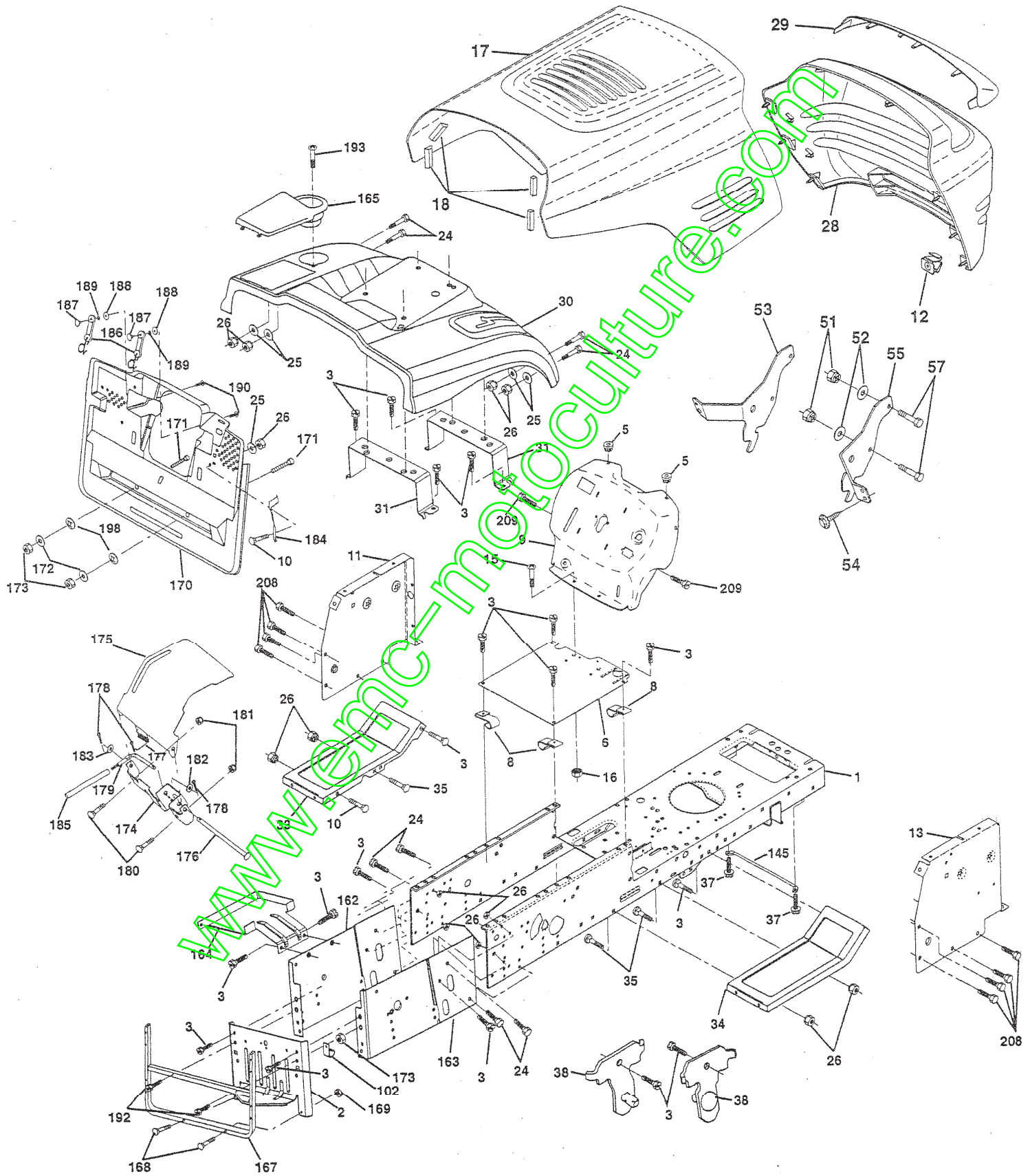

REPAIR PARTS

TRACTOR- -MODEL NO. 917.259441

CHASSIS AND ENCLOSURES

KEY NO.	PART NO.	DESCRIPTION	KEY NO.	PART NO.	DESCRIPTION
1	169831	Chassis Assembly	145	165624	Rod Pivot Chassis/Hood
2	165606	Drawbar	162	165672	Bracket Exten Chassis Lh CRD
3	17060612	Screw 3/8-16 x .75	163	165673	Bracket Exten Chassis Rh CRD
5	155272	BumperHood/Dash	164	165605	Support Battery CRD
6	155923	Saddle	165	165742X428	Cover Battery CRD Lt
8	126471X	Clip Insulator 13/32 Mtg. Hole	167	165779	Support Asm. Backplate WLDMM
9	168352X010	Dash SIKscr	168	72050412	Bolt, RDHD SHT NK 1/4-20 x 1-
10	STD533710	Bolt, Carriage 3/8-16 x 1	169	123976X	Nut, Lock 1/4 LGE FLG Gr. 5 Zir
11	155927	Panel, Dash, L.H.	170	165607	Cover, Backplate Plastic Black
12	145660	Clip, Tinnerman Grille P/L	171	74520640	Bolt, Fin Hex 3/8-16 x 2-1/2 Gr. 5
13	169117X010	Panel, Asm. Dash R.H.	172	19732616	Washer 13/32 x 1-1/4 x 16 Ga.
14	17670608	Screw Thdrol 3/8-16 x 1/2 TYT	173	STD541437	Nut, Keps Hex 3/8-16 UNC
15	74180512	Screw, Machine, Truss Head 5/16-18 UNC x 3/4	174	165939	Bracket Switch FBI CRD
16	STD541431	Nut Keps 5/16-18 UNC	175	166212	Guard Door Rear CRD
17	144983X558	Hood Assembly	176	128600	Pin Hinge Pivot
18	126938X	BumperHood	177	132796	Spring Bagger Top LH Black
24	STD523710	Bolt Fin Hex 3/8-16 UNC x 1. Gr 5	178	STD560907	Pin Cotter 3/32 x 3/4 Cad Zinc
25	19131312	Washer 13/32 x 13/16 x 12 Gauge	179	165942	Rod Pivot FBI CRD
26	STD541437	Nut Lock Hex w/Ins 3/8-16 UNC	180	74760516	Bolt Hex HD 5/16-18 UNC x 1
28	166271X558	Grille PL	181	STD541431	Nut Crownlock 5/16-18
29	155217X599	Lens, Grille	182	138200	Washer .385 x .625 x 11 Ga.
30	165714X558	Fender	183	STD551037	Washer 13/32 x 13/16 x 16 Ga.
31	165156	Bracket, Fender Support	184	166139	Bracket Actuator Bagger CRD
33	145244X558	Footrest, L.H.	185	165940	Tube Lever Switch FBI CRD
34	145243X558	Footrest, R.H.	186	160793	Latch Asm Mulch/Bagger
35	STD533107	Bolt RDHD SHT SQNK 3/8-16 x 3/4	187	2029J	Nut Weld .327/.304 #10-24
37	17490508	Screw Thdrol 5/16-18 x 1/2 TYT	188	19061216	Washer #10
38	169834	Pivot Bracket Assembly	189	STD551110	Washer Lock #10
51	73800400	Nut Lock w/Insert 1/4-20 UNC	190	71161010	Screw Truss Hd Phil 10-24 x 5/16
52	19091416	Washer 9/32 x 7/8 x 16 Ga.	192	17490624	Screw Thdrol 3/8-16 x 1-1/2
53	145201	Bracket, Grille LH	193	17070412	Screw Truss 1/4-20 x 3/4 Tap/F
54	161464	Screw Hex WSHD 5/16 x 7/8	198	168937	Nut, Push
55	145202	Bracket, Grille RH	209	17000612	Screw Hex Wsh Thdrol 3/8-16
57	STD522507	Bolt, Fin Hex 1/4-20 UNC x .75	--	5479J	Plug, Button
102	2751R	Clip line File 13/32 Mtg Hole			

NOTE: All component dimensions given in U.S. in 1 inch = 25.4 mm.

REPAIR PARTS

TRACTOR- -MODEL NO. 917.259441

DRIVE

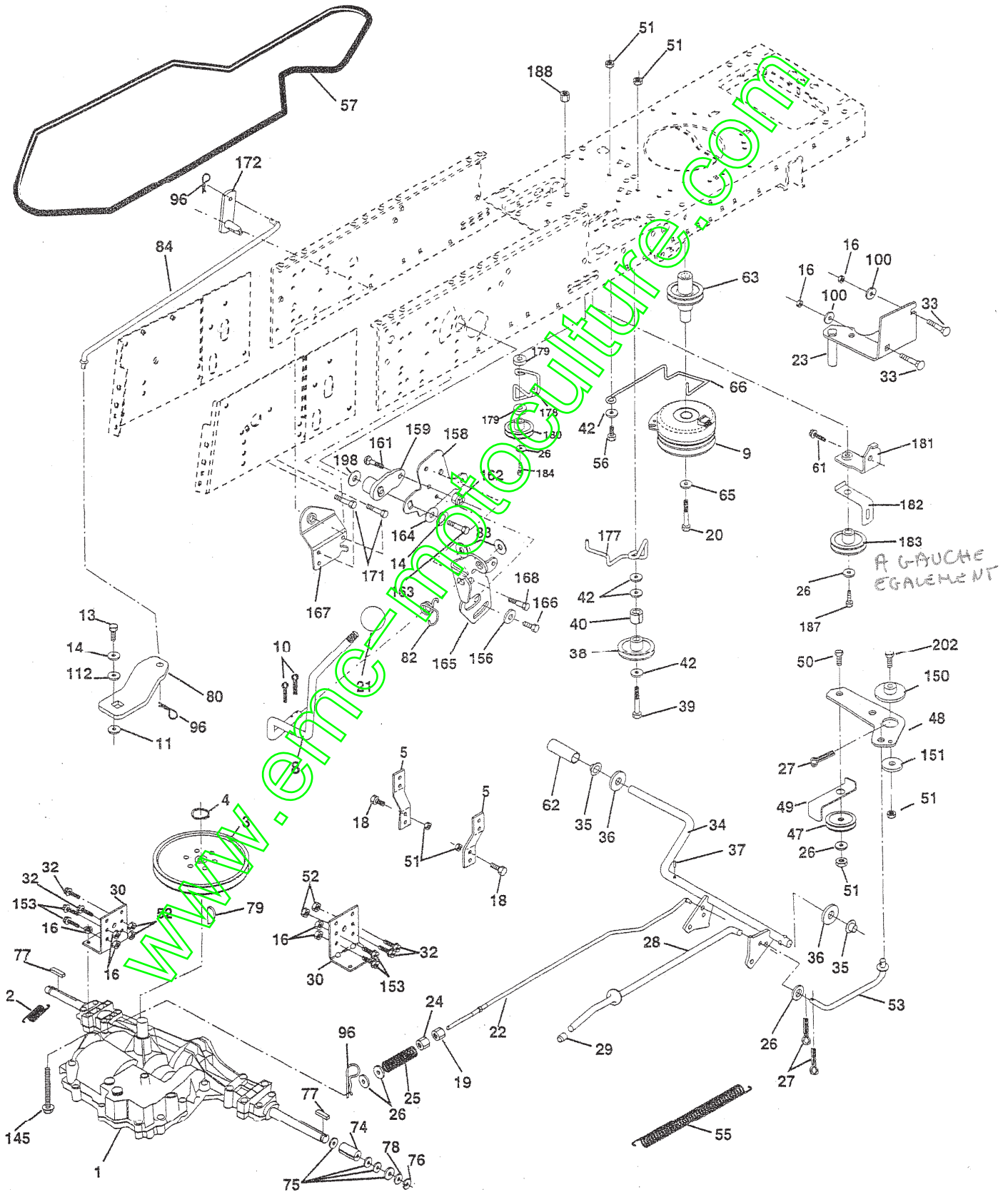

REPAIR PARTS

TRACTOR- -MODEL NO. 917.259441

DRIVE

KEY NO.	PART NO.	DESCRIPTION	KEY NO.	PART NO.	DESCRIPTION
1	-----	Transaxle (See Breakdown)	63	145868	Pulley, Clutch elect EVX 1"
2	146682	Peerless 206-546	65	STD551143	Washer
3	165999	Spring Brake Return	66	154778	Keeper, Belt Engine F-Proof
4	12000028	Pulley Transaxle	74	137057	Spacer, Axle
5	121520X	Ring Retainer #5100-62	75	121749X	Washer 25/32 x 1-1/4 x 16 Ga.
8	165619	Strap Torque 30 Degrees	76	STD581075	Ring, E
9	167162	Rod, Shift Fender Adjust Lt	77	123583X	Key, Square
10	STD561210	Clutch Ele EVX 80 W/Hard Brake	78	121748X	Washer 25/32 x 1-5/8 x 16 Ga.
11	105701X	Pin, Cotter 1/8 x 1	79	STD580025	Key Woodruff #9 3/16 x 3/4
13	74550412	Wash Plate Sht .388 Square Hole	80	145090	Arm Shift Pmst 20" Tires
14	STD551125	Bolt 1/4-28 Unf Gr 8 w/Patch	82	123782X	Spring, Torsion
16	STD541431	Washer, Lock Hvy Helical	83	19171216	Washer 17/32 x 3/4 x 16 Ga.
18	STD523710	Nut Lock Hex W/Wsh 5/16-18 Unc	84	165621	Link, Shift
19	STD541437	Bolt Hex 3/8-16 UNC x 1 Gr.5	96	STD624003	Spring, Retainer 1"
20	150280	Nut Lock Hex W/Wsh 3/8-16 Unc	100	19111216	Washer 11/32 x 3/4 x 16 Ga.
21	106933X	Bolt, Hex 7/16-20 x 4-1/4 5 Ga 1.38	112	19091210	Washer 9/32 x 3/4 x 10 Ga
22	165811	Knob Rd 1/2-13 Plstc Thds Blk	145	74490540	Bolt Hex FGHD 5/16-18 x Gr 5
23	171258	Rod, Brake CRD Pmst	150	165850	Bushing, Bellcrank Grnd Dr
24	STD541237	Bracket asm Clutch Mtg. EVX	151	19133210	Washer 13/32 x 2 x 10 Ga.
25	106888X	Nut Hex Jam 3/8-16 UNC	153	74760516	Bolt Hex Hd 5/16-18 Unc x 1
26	STD551037	Spring, Rod, Brake	156	166002	Washer Srrtd 5/16ID x 1.125
27	STD561210	Washer 13/32 x 13/16 x 16 Ga.	158	165589	Bracket Shift Mount
28	145204	Pin, Cotter 1/8 x 3/4	159	165494	Hub Tapered Flange Shift Lt
29	71673	Rod, Parking Brake	161	72140406	Bolt Rdhd Sqnk 1/4-20 x 3/4 Gr 5
30	130807	Cap, Parking Brake	162	73680400	Nut Crownlock 1/4-20 Unc
32	STD523107	Bracket, Mfg. Transaxle	163	74780416	Bolt Hex Fin 1/4-20 Unc x 1 Gr 5
33	STD533107	Bolt Hex 5/16-18 UNC x 3/4	164	19091010	Washer 5/8 x .281 x 10 Ga.
34	165496	Bolt Rdhd Sqnk 5/16-18 Unc x 3/4	165	165623	Bracket Pivot Lever
35	120183X	Shaft, Asm Pedal Foot CRD	166	166880	Screw 5/16-18 x 5/8
36	STD551062	Bearing, Nylon	167	165588	Bracket Support Shift CRD
37	STD571810	Washer 21/32 x 1 x 16 Ga.	168	165492	Bolt Shoulder 5/16-18 x .561
38	165936	Pin, Roll 3/16 x 1"	171	17490608	Screw Thdrol 3/8-16 x 1/2 Ty-Tt
39	72110622	Pulley Flat Composite 3.06"	172	165635	Shaft Shift Front CRD
40	4470J	Bolt RDHD 3/8-16 x 2-3/4 Gr. 5	177	165932	Keeper Flat Idler 3.06" CRD
42	19131312	Spacer, Split 395 x .59 Bzp	178	165933	Keeper Belt Idler 1.88" CRD
44	127783	Washer 13/32 x 13/16 x 12 Ga.	179	120958X	Washer Sintered
46	154407	Pulley, Idler, V-Groove Plstic	180	165630	Pulley Flat Idler 1.88"
47	123205X	Bellcrank Clutch Grnd Drv	181	165797	Bracket Idler Ground Drive CRD
48	123205X	Retainer, Belt Style Spring	182	165634	Keeper Belt 2.5" Od V-Idler CRD
49	STD523715	Bolt Hex Hd 3/8-16 UNC x 1-1/2	183	165626	Pulley V-Idler 2.50" Od CRD
50	STD541437	Nut, Crownlock 3/8-16 UNC	184	17490644	Screw Hexwsh Thdrol 3/8-16 x 2-
51	STD541431	Nut Crownlock 5/16-18	187	17490620	Screw Thdrol 3/8-16 x 1-1/4 TT
52	105710X	Nut Crownlock 5/16-18	188	110436X	Bushing Snap Split
53	105709X	Link, Clutch 7.66	198	169593	Washer Nyl 7/8 ID x 105" Hyd CF
54	105709X	Spring, Return, Clutch	202	72110612	Bolt Carr. SH 3/8-16 x 1-1/2 Gr. 5
55	105709X	Bolt, Hex 3/8-16 UNC x 1-1/4			
56	STD523712	V-Belt Kev 111" Pmst CRD			
57	165631	Screw 3/8-16 x .75 SMGML Tap/R			
61	17060612	Cover, Pedal			
62	8883R				

NOTE: All component dimensions given in U.S. inc
1 inch = 25.4 mm

REPAIR PARTS

TRACTOR- -MODEL NO. 917.259441

STEERING ASSEMBLY

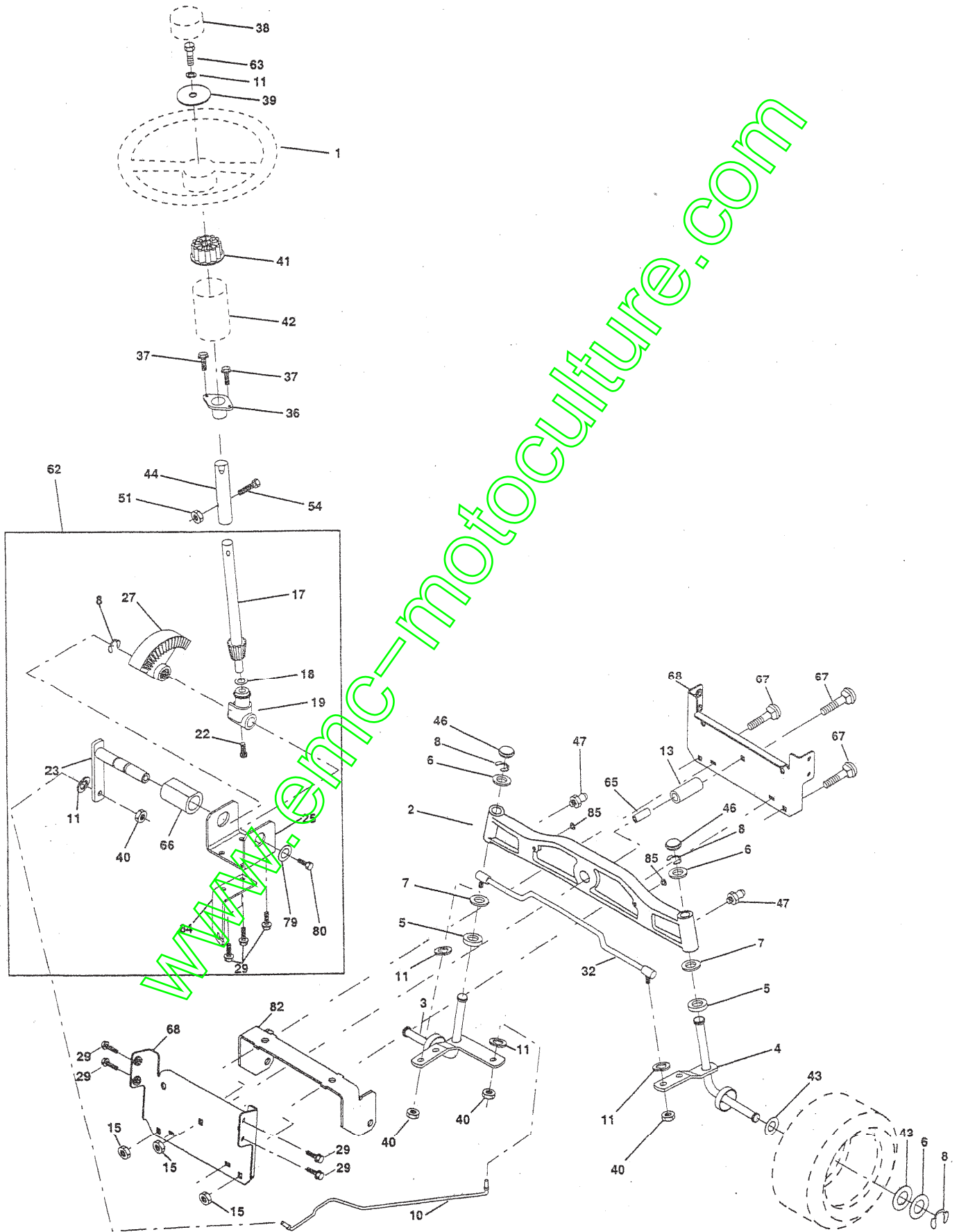

REPAIR PARTS

TRACTOR- -MODEL NO. 917.259441

STEERING ASSEMBLY

KEY NO.	PART NO.	DESCRIPTION
1	139768	Steering Wheel
2	165854	Front Axle Assembly
3	169840	Spindle Assembly, L.H.
4	169839	Spindle Assembly, R.H.
5	6266H	Bearing, Race, Thrust, Hardened
6	121748X	Washer 25/32 x 1-5/8 x 16 Gauge
7	19272016	Washer 27/32 x 1-1/4 x 16 Gauge
8	12000029	Ring, Klip
10	169832	Link, Drag
11	STD551137	Washer, Lock
13	136518	Spacer Axle
15	145212	Nut, Hexflange Lock
17	156546	Shaft Assembly, Steering
18	57079	Washer, Thrust 515 x .750 x .033
19	160395	Support, Shaft
22	165857	Screw Hex Wshhd Torx
23	165851	Pittman Shaft Assembly
25	154406	Bracket, Steering
27	136874	Gear, Sector
29	17060612	Screw 3/8-16 x 3/4 SMGML Tap/R
32	170162	Rod, Tie
36	155099	Bushing, Steering
37	152927	Screw TT #10-32 x 5 x 3/8 Flange
38	139769	Cap Wheel Steering
39	19133812	Washer 13/32 x 2-3/8 x 12 Gauge
40	STD541537	Nut Lock Center 3/8-24 Unf
41	100711L	Adaptor, Steering Wheel
42	145054X428	Boot, Steering Dash
43	121749X	Washer 25/32 x 1-1/4 x 16 Gauge
44	158720	Extension Steering Non-Adjust
46	121232X	Cap, Spindle
47	6855M	Fitting, Grease
51	STD541431	Nut Lock Hx W/Ins 5/16-18 UNC
54	STD523112	Bolt Fin Hex 5/16-18 UNC x 1-1/4
52	167902	Kit, Steering Assembly, Service
63	STD523710	Bolt Fin Hex 3/8-16 unc. x 1 Gr. 5
65	160367	Spacer Brace Axle
66	154404	Bearing Arm Pittman
67	72110618	Bolt RDHD SQNK 3/8-16 x 2-1/4
68	169827	Brace Axle
79	19132012	Washer 13/32 x 1-1/4 x 12 Ga
80	74950612	Bolt Hex Nylon 3/8-16 x 3/4
82	169835	Bracket Susp Chassis Front
84	170016	Bracket Cable Clutch Chassis
85	133835	Fastener Christmas Tree

NOTE: All component dimensions given in U.S. inches.
1 inch = 25.4 mm.

REPAIR PARTS

TRACTOR- -MODEL NO. 917.259441

SEAT ASSEMBLY

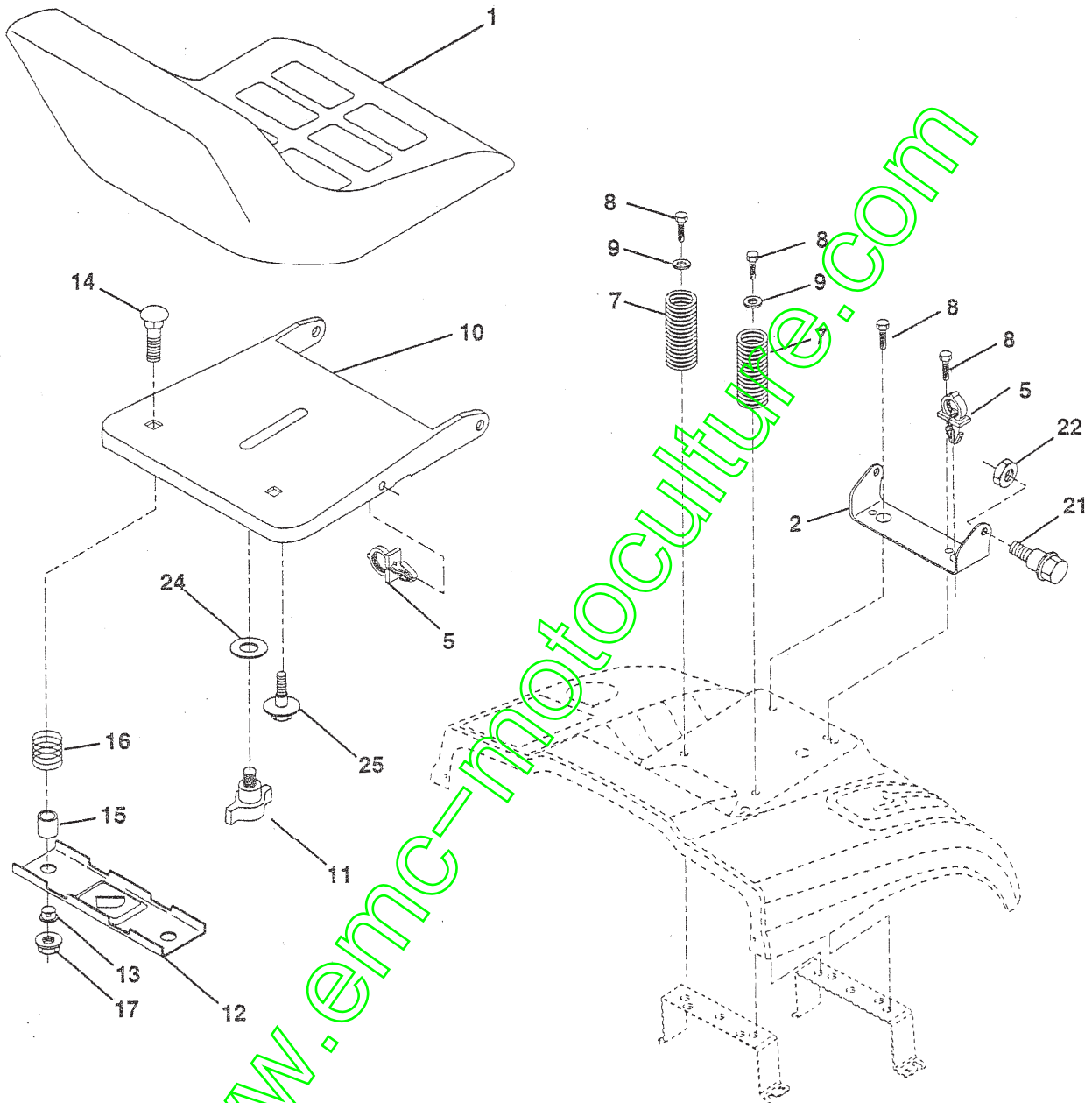

KEY NO.	PART NO.	DESCRIPTION
1	140122	Seat
2	140551	Bracket Pnt Pivot Seat (blk)
5	145006	Clip Push In Hinged
7	124181X	Spring Seat Cprsn 2 250 Blk Zi
9	19131614	Washer 13/32 X 1 X 14 Ga
10	155925	Pan Pnt Seat (blk)
11	166369	Knob Seat Adj Wingnut
12	121246X	Bracket Pnt Mounting Switch
13	121248X	Bushing Snap Blk Nyl 50 Id
14	72050412	Bolt Rdhd Sht Nk 1/4-20x1-1/2

KEY NO.	PART NO.	DESCRIPTION
15	134300	Spacer Split .28 X .96 Zinc
16	121250X	Spring Cprsn
17	123976X	Nut Lock 1/4 Lge Flg Gr 5 Zinc
21	171852	Bolt Shoulder 5/16-18 Unc-2A
22	73800500	Nut Hex Lock w/Ins 5/16-18
24	19171912	Washer 17/32 X 1-3/16 X 12 Ga.
25	127018X	Bolt Shoulder 5/16-18 X 62

NOTE: All component dimensions given in U.S. inches.
1 inch = 25.4 mm

REPAIR PARTS

TRACTOR- -MODEL NO. 917.259441

DECALS

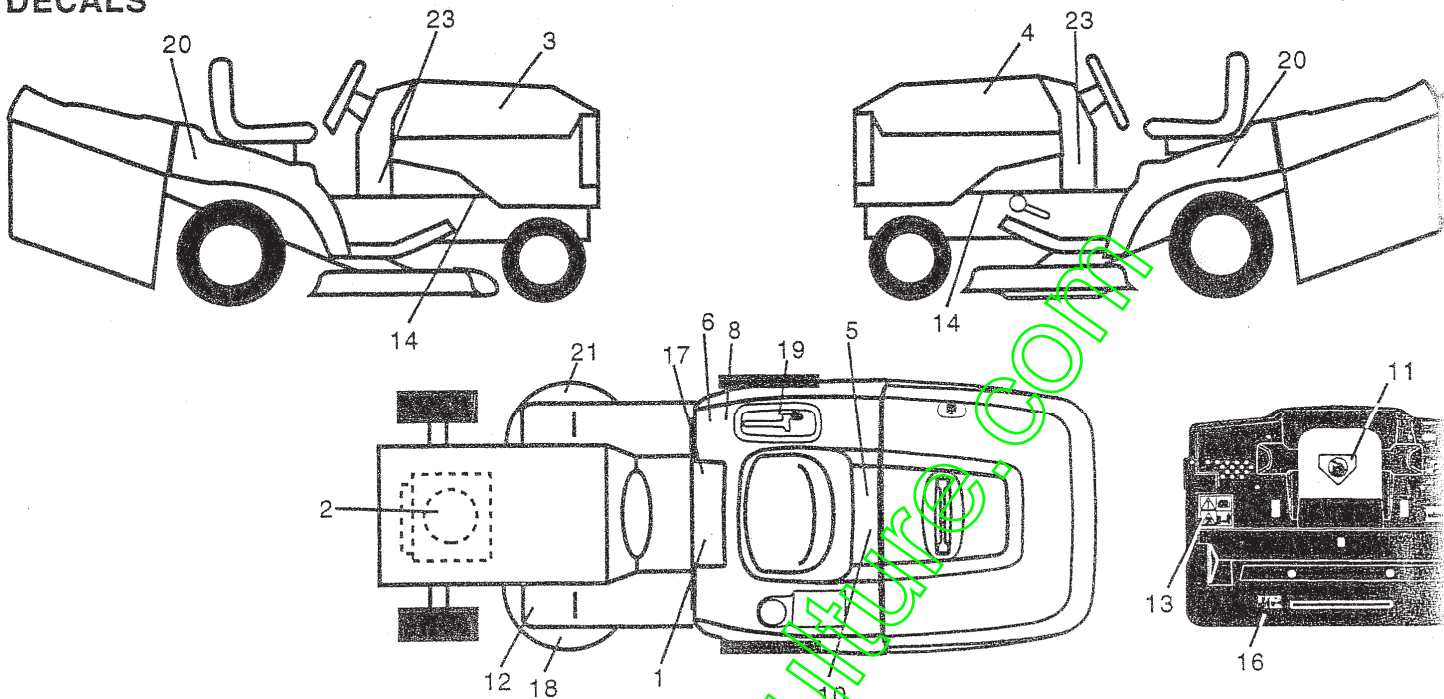

KEY NO.	PART NO.	DESCRIPTION	KEY NO.	PART NO.	DESCRIPTION
1	145498	Decal Read Owner's Manual Sym	15	166961	Decal Oper Bag Presence CRD
2	165393	Decal Hp Engine	16	162598	Decal Drawbar Load Limit
3	171696	Decal Hood Rh	17	140837	Decal Saddle Brake Parking
4	171697	Decal Hood Lh	18	133179	Decal Mower QC System
5	166960	Decal Bypass Fender	19	166963	Decal Console CRD White
6	126187X	Decal 100 DBA	20	168663	Decal Fender 6/36 Sears Euro
8	145437	Decal Europe Stand Ce	21	166286	Decal Deck Sch 92 CRD
9	163204	Decal Fender Logo	23	163249	Decal Panel Dash
10	145005	Decal Bat Dan/Poi P/L Sym Wpn	—	138311	Decal Lift Handle
11	145494	Decal Mower Cut Finger Symbol	—	157199X428	Pad Footrest
12	159737	Decal Brake/Clutch Symbol Lt	—	172039	Manual Operator's (Euro)
13	166959	Decal Warn Back Plate CRD	—	172040	Manual Operator's (Scand)
14	159736	Decal Chassis Hot Muffler	—	172041	Manual Parts

WHEELS & TIRES

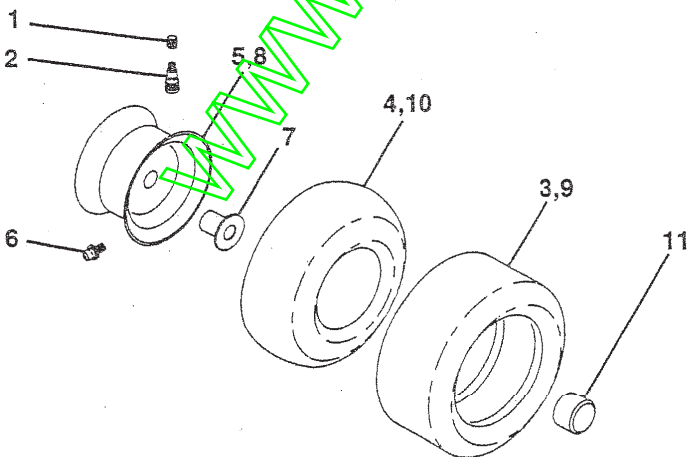

KEY NO.	PART NO.	DESCRIPTION
1	59192	Cap Value Tire
2	65139	Stem Value
3	106222X	Tire F Ts 15 X 6 0 - 6 Service
4	59904	Tube Inner Front #35060
5	106732X427	Rim Asm 6" front White Service
6	278H	Fitting Grease
7	9040H	Bearing Flange
8	106108X427	Rim Asm 8" rear White Service
9	106268X	Tire R Ts 18 x 9.5-8 Service
10	7152J	Tube Rear 9 5 X 8 Service
11	104757X	Cap Axle Blk 1 50 X 1 00
--	144334	Sealant, Tire (10 oz. tube)

NOTE: All component dimensions given in U.S. inch
1 inch = 25.4 mm

REPAIR PARTS

TRACTOR- -MODEL NO. 917.259441

ENGINE

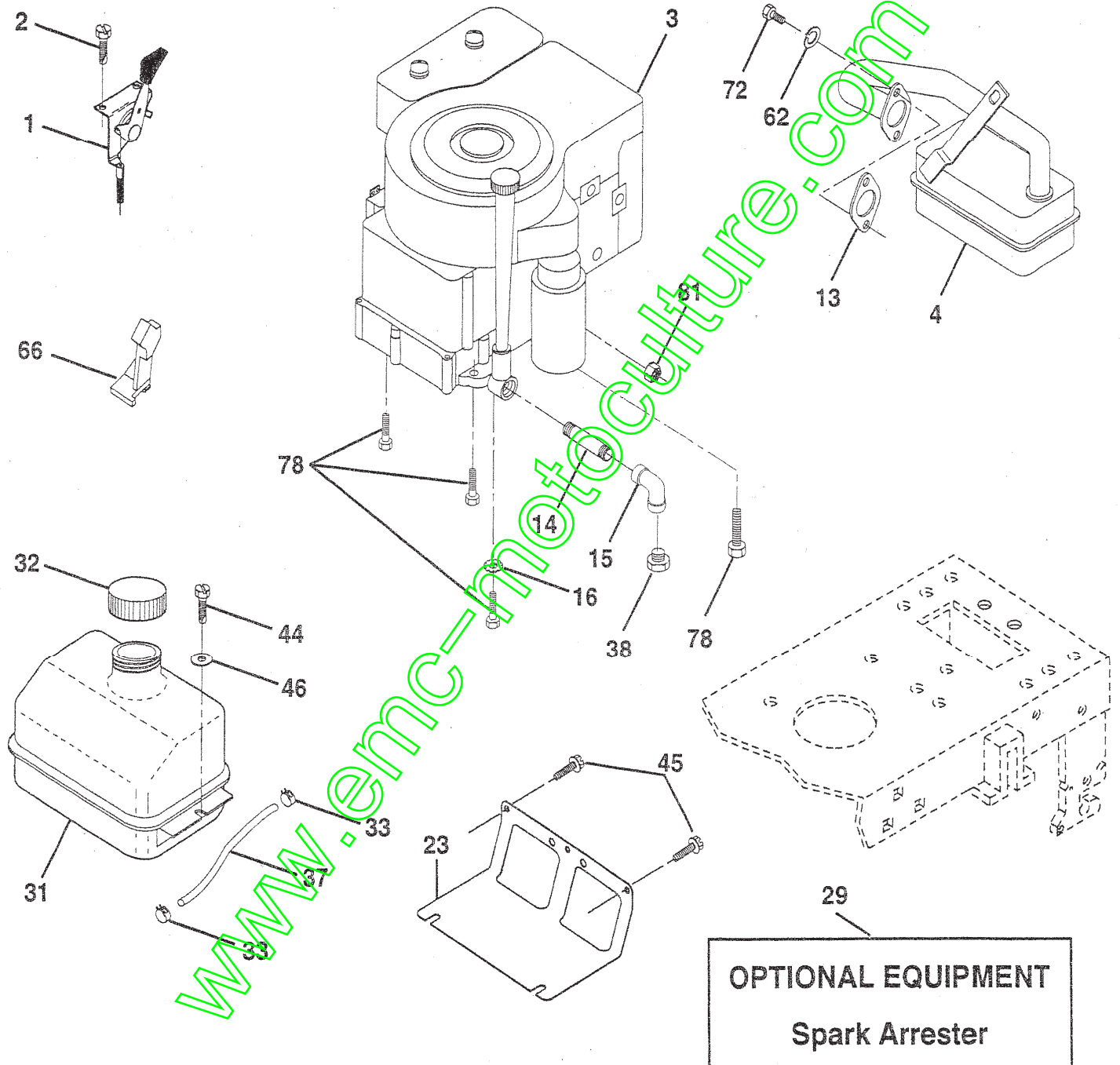

REPAIR PARTS

TRACTOR- -MODEL NO. 917.259441

ENGINE

KEY NO.	PART NO.	DESCRIPTION
1	162158	Control Throt/Ch Lh
2	17720410	Screw Hex Thd Cut 1/4-20x5/8 T
3	-----	Engine (See Breakdown) Briggs Model 287707-1277-E1
4	137352	Muffler Exhaust B&S Lt
13	165291	Gasket 1 313 Id Tin Plated
14	13280324	Nipple Pipe 3/8 Npt X 3"
15	13200300	Elbow Std 90 Degree 3/8-18 Npt
16	STD551237	Washer Lock Ext Tooth 3/8
23	169837	Shield Browning/Debris Guard
29	137180	Arrestor Spark
31	109202X	Tank Fuel 1.25 Fr
32	158990	Cap Asm Fuel
33	123487X	Clamp Hose Blk
37	137040	Line Fuel 20"
38	-----	Plug Oil Drain (See Engine Breakdown)
44	17490412	Screw Hexwsh Thdrol 1/4-20x3/4
45	17060612	Screw 3/8-16 x .75 SMGML Tap/R
46	19091416	Washer 9/32 X 7/8 X 16ga
62	STD551131	Washer Lock Hvy Hchl Spr 5/16
66	127951	Stop Throttle 3000 Rpm
72	71070512	Screw Hexhd Cap 5/16-18x3/4
78	17490620	Screw Thdrol 3/8-16x1-1/4 Tytt
81	128861	Nut Flange 1/4-20 Starter Nut

NOTE: All component dimensions given in U.S. inches
1 inch = 25.4 mm

REPAIR PARTS

TRACTOR- -MODEL NO. 917.259441

MOWER LIFT

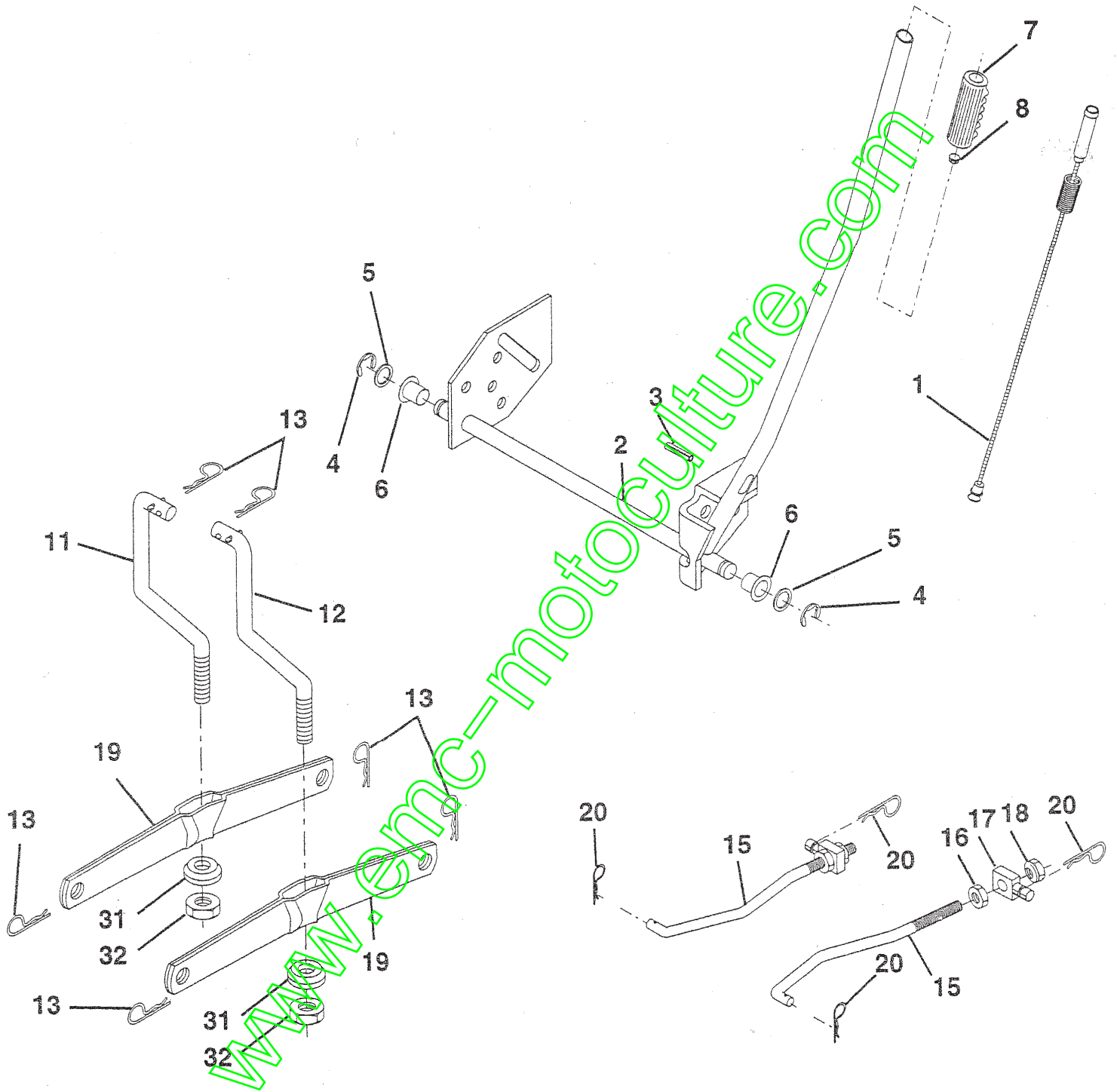

REPAIR PARTS

TRACTOR- -MODEL NO. 917.259441

MOWER LIFT

KEY NO.	PART NO.	DESCRIPTION
1	159460	Washer Asm Inner Spring W/Plunger
2	159471	Shaft Asm. Lift
3	105767X	Pin Groove
4	STD581062	ERing #5133-62
5	19211621	Washer 21/32 x 1 x 21 Ga.
6	120183X	Bearing Nylon
7	125631X	Grip Handle
8	122365X	Button Plunger Red
11	165829	Link Asm Lift L.H.
12	165831	Link Asm Lift R.H.
13	STD624008	Retainer Spring
15	167253	Link Front
16	73350800	Nut Jam Hex 1/2-13 Unc
17	130171	Trunnion Blk Zinc
18	73680800	Nut Crownlock 1/2-13 Unc
19	139868	Arm Suspension Mower
20	163552	Retainer Spring
31	140302	Bearing Pvt. Lift. Spherical
32	73540600	Nut Crownlock 3/8-24

NOTE: All component dimensions given in U.S. inches
1 inch = 25.4 mm

REPAIR PARTS

TRACTOR- -MODEL NO. 917.259441

MOWER

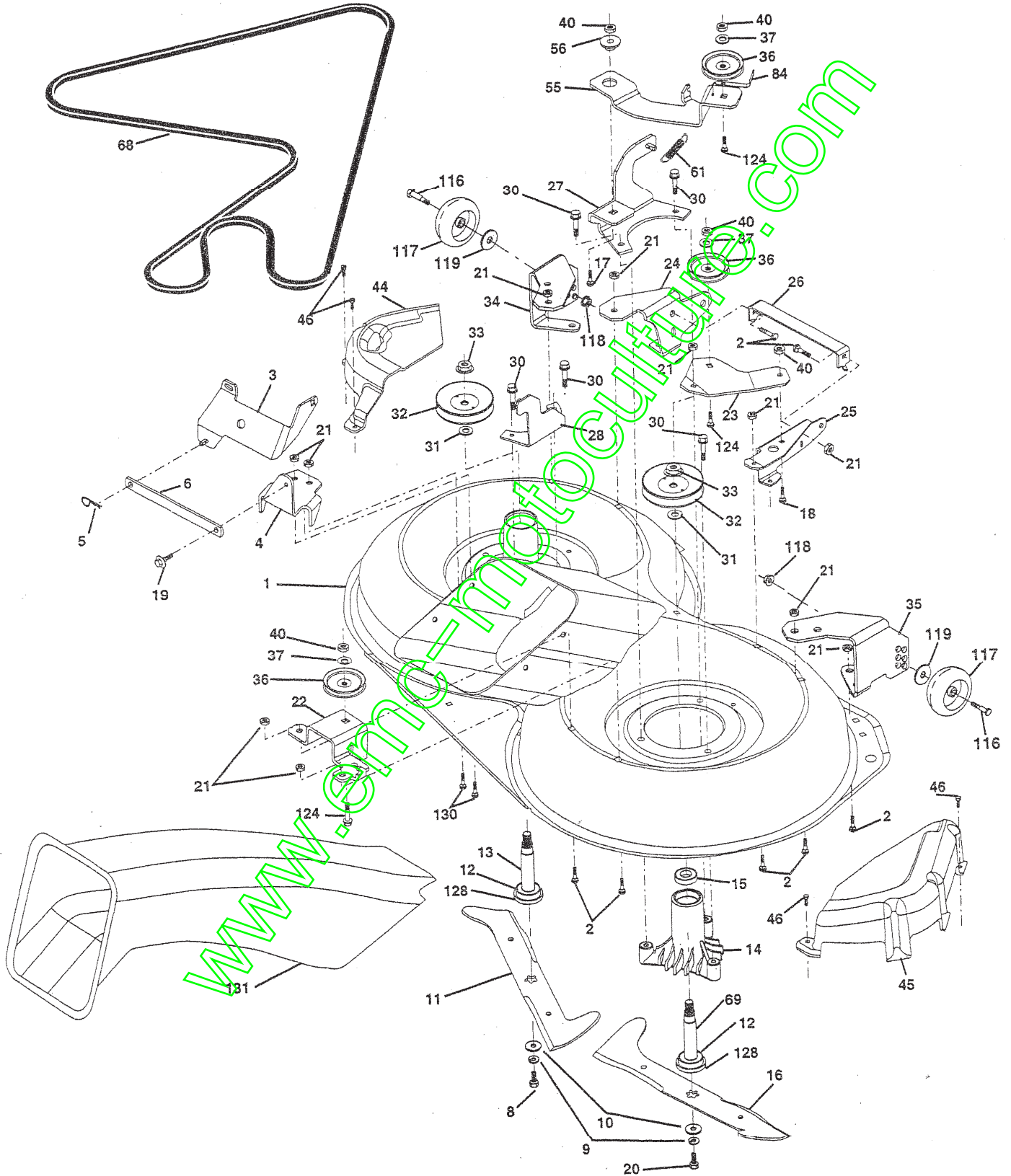

REPAIR PARTS

TRACTOR- -MODEL NO. 917.259441

MOWER

KEY NO.	PART NO.	DESCRIPTION	KEY NO.	PART NO.	DESCRIPTION
1	165552	Housing Asm. Mower 92 CRD	37	STD551037	Washer 11/32 x 13/16 x 16 Ga
2	STD533107	Bolt Rdhd Sqnk 5/16-18 Unc x 3/4	40	STD541437	Nut Crownlock 3/8-16 Unc
3	165569	Bracket Asm. S-Bar Chass 92 CRD	44	165724	Cover Mandrel Lh 92 CRD
4	165558	Bracket Bar Sway Deck 92 CRD	45	165556	Cover Mandrel Rh 92 CRD
5	STD624008	Retainer Spring	46	137729	Screw Thd Roll 1/4-20 x 5/8
6	165557	Bar Sway 92 CRD	55	165445	Arm Idler 92 CRD
8	850857	Bolt 3/8-24 x 1.25 Gr8 Patched	56	165723	Spacer Retainer PM Mower
9	STD551137	Washer Lock Hvy 3/8 Unplated	61	165945	Spring Tension Belt
10	140296	Washer Hard Blade Mower vented	67	1069323	Knob Rd 3/8-16 Plstc Thds
11	170037	Blade 3-1 Lh 92 CRD	68	165555	Hex-Belt 92 Mower 105AA
12	129895	Bearing Ball #6204 (Mandrel)	69	165482	Shaft Asm W/Lwr Brg Rh Thd CRD
13	137645	Shaft Asm. W/Lower Bearing	84	156085	Keeper Belt Idler
14	128774	Housing Mandrel Vented (Machd)	116	137644	Bolt Shoulder
15	110485X	Bearing Ball Mandrel	117	133957	Wheel Gauge
16	170038	Blade 3-1 Rh 92 CRD	118	13930600	Nut Centerlock 3/8-16 Unc.
17	STD533712	Bolt Carriage 3/8-16 x 1-1/4	119	19121414	Washer 3/8 x 7/8 x 14 Ga
18	STD533710	Bolt Rdhd Sqnk 3/8-16 x 1 Gr5	124	72110612	Bolt Carr Sh 3/8-16 x 1-1/2 Gr5
19	132827	Bolt Shoulder 5/16-18 Thd Form	128	153390	Washer Felt
20	165484	Bolt 3/8-24 x 1.25 Gr8 Ptch Lhthd	130	STD533107	Bolt Rdhdsqnk 5/16-18 Unc x 3/4
21	STD541431	Nut Crown Lock 5/16-18	131	165661	Chute Bagger CRD 92cm
22	165243	Bracket Idler Sprt RR 92 CRD	151	169670	Bracket Clutch Cable
23	165446	Bracket Idler Sprt RF 92 CRD	152	170300	Cable Clutch
24	165242	Bracket Suspension LF 92 CRD	153	169674	Washer Flat 3/8" Type B
25	165244	Bracket Suspension RF 92 CRD	154	169675	Spring Retainer
26	165237	Brace Support Susp Frt CRD	155	169671	Spring Retainer
27	165568	Bracket Asm. Susp RR 92 CRD	156	169672	Spacer Clutch Cable
28	165567	Bracket Asm. Susp LR 92 CRD	157	169669	Rod Clutch Cable 3/8"
30	157722	Screw Thd Rolling Washer Head	158	17720410	Screw Hex Thdcut 1/4-20 x 5/8
31	129963	Washer Spacer Mower vented	-	130794	Mandrel Asm Service
32	153531	Mandrel Pulleys 36 & 46	-	165579	Mandrel Asm CRD Lh Threads SV
33	137266	Nut Flg Top Lock Ontr B 9/16	-	165578	Deck Mower Complete
34	165239	Bracket Gauge Wheel Lf 92 CRD			
35	165238	Bracket Gauge Wheel Rf 92 CRD			
36	146763	Pulley Idler V-Groove Dim 4.25			

NOTE: All component dimensions given in U.S. inches
1 inch = 25.4 mm

REPAIR PARTS

TRACTOR- -MODEL NO. 917.259441

BAGGER

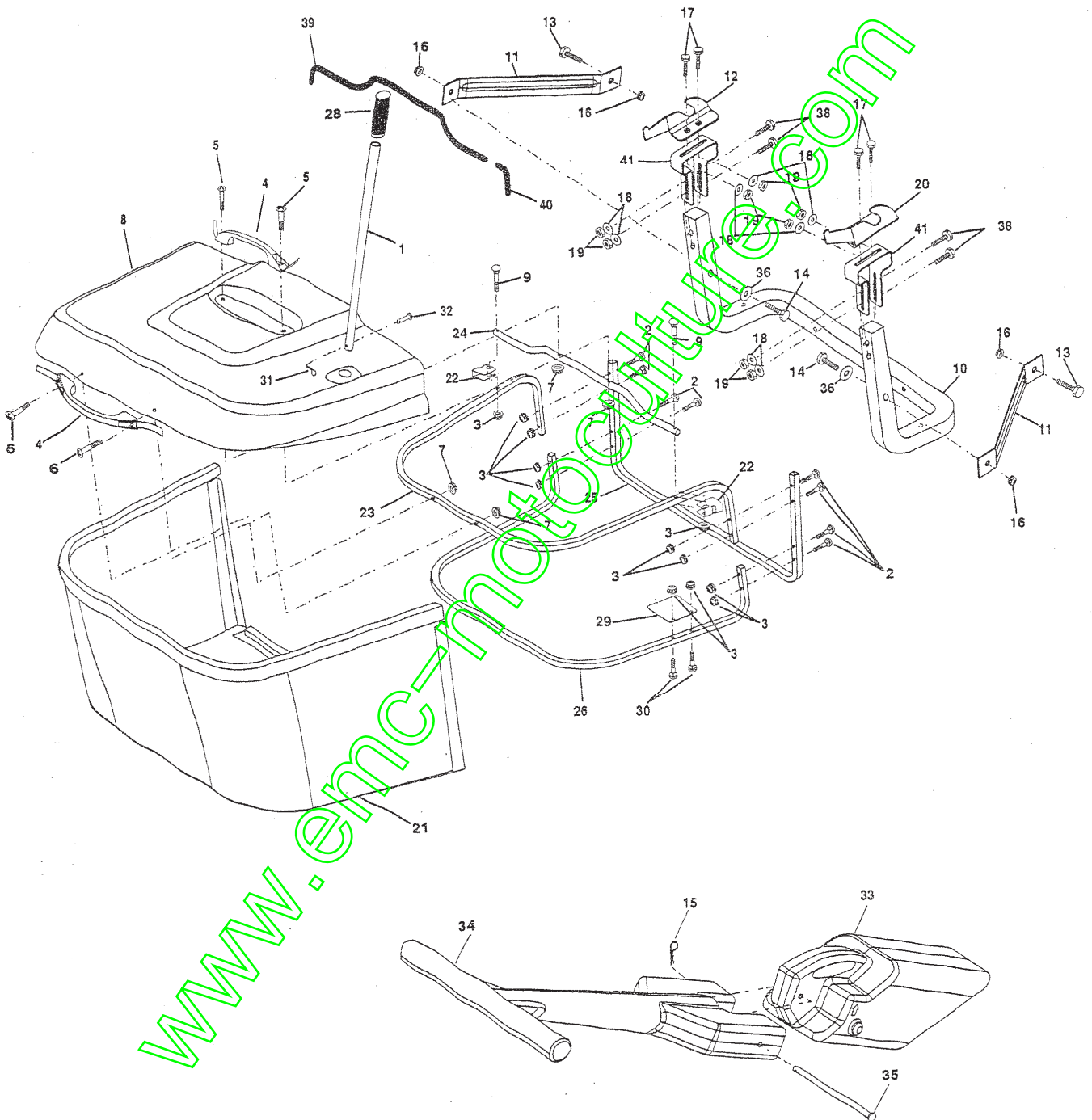

REPAIR PARTS

TRACTOR- -MODEL NO. 917.259441

BAGGER

KEY NO.	PART NO.	DESCRIPTION
1	165249	Tube Handle Bagger CRD
2	72140416	Bolt Carriage 1/4-20 x 2.0 Gr.5
3	123976X	Nut Lock 1/4 Lge Fig Gr. 5 Zinc
4	169916	Handle Bagger
5	74981024	Screw Pan Head #10-24 x 1.50 Blk
6	74981032	Screw Pan Hd
7	73401000	Nut Wiz Lock Hex Serr/Hd 10-24
8	165715X558	Cover Bagger Plastic CRD
9	72140418	Bolt Carriage 1/4-20 x 2.05d x Gr.5
10	169688	Tube Support Bagger CRD
11	165719	Bracket Support Upper Bag CRD
12	169685	Bracket Pivot Bagger Lh CRD
13	STD533707	Bolt Rdhd Sht Sqnk 3/8-16 x 3/4
14	74520640	Bolt Hex 3/8-16 x 2-1/2 Gr.5
15	4939M	Retainer Spring
16	73900600	Nut Lock Fig 3/8-16 Unc
17	STD533107	Bolt Rdhd Sht Sqnk 5/16 -18 Unc x 3/4
18	19111216	Washer 11/32 x 3/4 x 16 Ga.
19	STD541431	Nut Lock Hex W/Ins 5/16-18 Unc Pl
20	169684	Bracket Horiz Adj Bagger RH CRD
21	165780	Bag Asm CRD
22	165781	Bracket Side Bagger CRD
23	165782	Tube Upper Bagger CRD
24	165783	Tube Pivot Bagger CRD
25	165784	Tube Front Bagger CRD
26	165785	Tube Lower Bagger CRD
27	169692	Bushing Snap Bagger CRD
28	165787	Grip Handle Black
29	165839	Plate Stop Bagger handle CRD
30	72140410	Bolt Carriage 1/4-20 x 1 Gr.5
31	STD624003	Retainer Spring 1" Zinc/Cad
32	126875X	Rivet Rd Hd Drilled 3/8 Dia
33	165571	Plug Mulcher
34	165570	Handle Mulcher
35	165572	Pin Mulcher
36	19132016	Washer 13/32 x 1-1/4 x 16 Ga.
38	72010520	Bolt 5/16-18 x 5.20
39	169999	Seal 26" (Long)
40	170000	Seal 7" (Short)
41	169683	Bracket Vert Adj Bagger CRD

NOTE: All component dimensions given in U.S. inches
1 inch = 25.4 mm

REPAIR PARTS

TRACTOR - - MODEL NUMBER 917.259441

PEERLESS PMST TRANSAXLE - MODEL NUMBER 206-546

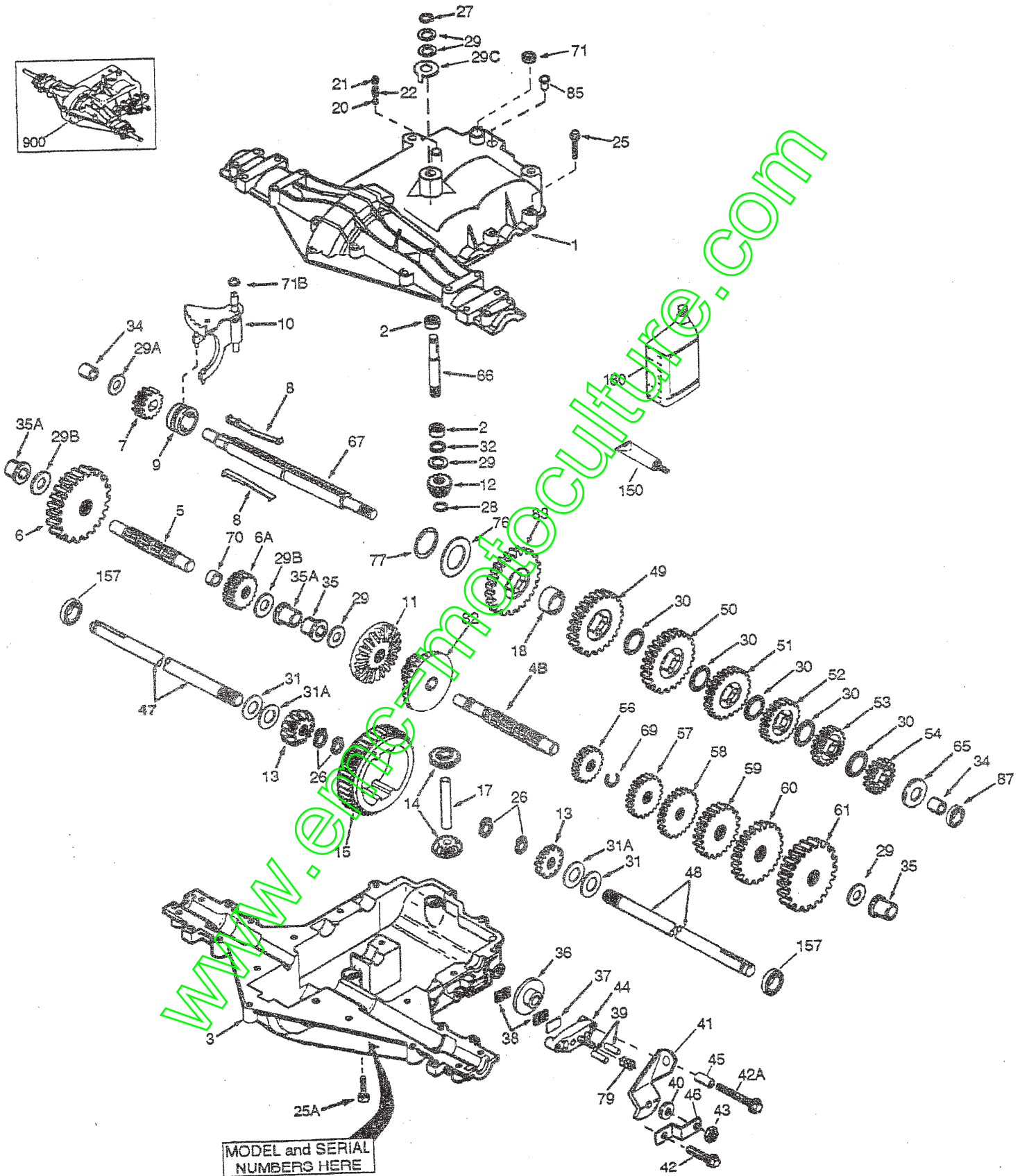

REPAIR PARTS

TRACTOR - - MODEL NUMBER 917.259441

PEERLESS PMST TRANSAXLE - MODEL NUMBER 206-546

KEY NO.	PART NO.	DESCRIPTION	KEY NO.	PART NO.	DESCRIPTION
1	772147	Transaxle Cover	42	792073A	Screw 1/4-20 x 1-1/4"
2	780086A	Needle Bearing 5/8"	42A	792085A	Screw 1/4-20 x 2-1/4"
3	770128	Transaxle Case	43	792075	Locknut 5/16-24
4B	776406	Countershaft	44	790025	Brake Pad Holder
5	776409	Output Shaft	45	786066	Spacer .2625 x 1.0
6	778364	Spur Gear (38 teeth)	46	786086	Brake Lever Bracket
6A	778369	Spur Gear (15 teeth-steel)	47	774690	Axle (1 1/2-15/16" long)
7	778330	Spur Gear (11 teeth)	48	774691	Axle (1 1/2" long)
8	792180	Shift Key	49	778336	Spur Gear (30 teeth)
9	784352	Shift Collar	50	778338	Spur Gear (27 teeth)
10	784378	Shift Rod & Fork	51	778340	Spur Gear (24 teeth)
11	778334	Bevel Gear (30 teeth)	52	778342	Spur Gear (22 teeth)
12	778309	Input Bevel Pinion (13 teeth)	53	778352	Spur Gear (19 teeth)
13	778368	Bevel Gear (13 teeth) (Incl. 14)	54	778350	Spur Gear (16 teeth)
14	778368	Bevel Pinion (13 teeth) (Incl. 13)	56	778335	Spur Gear (10 teeth-steel)
15	778370	Ring Gear (43 teeth)	57	778337	Spur Gear (13 teeth)
17	786188	Drive Pin	58	778339	Spur Gear (16 teeth)
18	786102	Spacer 1.130 X .695	59	778341	Spur Gear (18 teeth)
20	792077A	Ball 5/16" dia	60	778351	Spur Gear (21 teeth)
21	792078	Set Screw 3/8-16 x 3/8"	61	778349	Spur Gear (24 teeth)
22	792079	Spring .310 OD x .625 L	65	780189	Flat Washer .563 ID x .062W
25	792073A	Screw 1/4-20 x 1-1/4" 17	66	776422	Input Shaft
25A	792177	Screw 1/4-20 x 1-3/8" 2	67	776396	Shifter & Brake Shaft
26	792125	Retaining Ring (pkg of 2)	69	792170	Retaining Ring
27	792035	Retaining Ring	70	786187	Spacer .890
28	788040	Retaining Ring	71	788069	Square Cut Ring
29	780072	Thrust Washer .627ID x .031W	71B	788092	"O" Ring
29A	780160	Thrust Washer .563 ID x .031W	76	780090	Flat Washer 1.128 ID x .058W
29B	780051	Thrust Washer .762 ID x .031W	77	788078A	Inverted Retaining Ring
29C	780199	Anti-Rotation Washer .632	79	792144	Spring .430 OD x .5000 L
30	780108	Cup Washer 1.127ID x .032W	82	778363	Bevel & Spur Gear (30 & 13 teeth)
31	780001	Flat Washer .750ID x .056W(Use As Needed)	83	778338	Spur Gear (27 teeth)
31A	780195	Flat Washer .750ID x .062W	85	792154	Oil Fill Plug
32	788083	Oil Seal 5/8"	87	788089A	Oil Seal 9/16"
34	780194	Bushing .563	150	788093A	Liquid Gasket RTV Silicone
35	780193	Flanged Bushing 5/8" ID 2	157	788088A	Oil Seal 3/4"
35A	780197	Flanged Bushing .751 2	180	730229A	Gear Oil 80W90
36	790075	Brake Disk	900	794715	Replacement 206-546 Transaxle
37	790007	Brake Pad Plate			
38	799021	Brake Pad (pkg of 2)			
39	786026	Dowel Pin 5/16 x 3/4			
40	792076A	Flat Washer .312 ID x .059W			
41	790094	Brake Lever			

Parts must be ordered from Tecumseh Products Co.

NOTE: All component dimensions given in U.S. inches
1 inch = 25.4 mm