

REPAIR PARTS MANUAL
MODEL NO. 259463
LAWN TRACTOR



HOW TO USE THIS MANUAL

This manual is designed to provide the customer with a means to identify the parts on his/her tractor when ordering repair parts. The illustrations may or may not represent the actual assemblies; therefore, it is not recommended to use this manual as a guide to assemble or disassemble the tractor. Some hardware and parts are drawn larger in order to more readily identify them.

Each tractor has its own model number.

The model number for your tractor can be found on the fender under the seat.

When ordering parts, always give the following information:

- Product - "Tractor"
- Model Number - "259463"
- Part Number
- Part Description

TABLE OF CONTENTS

SCHEMATIC.....	3
ELECTRICAL.....	4-5
CHASSIS.....	6-7
DRIVE.....	8-9
STEERING.....	10-11
SEAT.....	12
DECALS.....	13
ENGINE.....	14-15
MOWER LIFT.....	16-17
MOWER DECK.....	18-19
BAGGER.....	20-21
TRANSAXLE.....	22-23
ENGINE BREAKDOWN.....	24-29
WARRANTY.....	32

SCHEMATIC

TRACTOR- -MODEL NO. 917. 259463

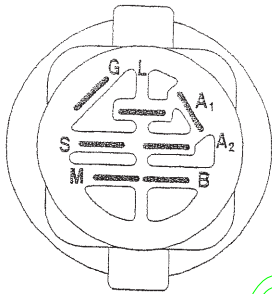
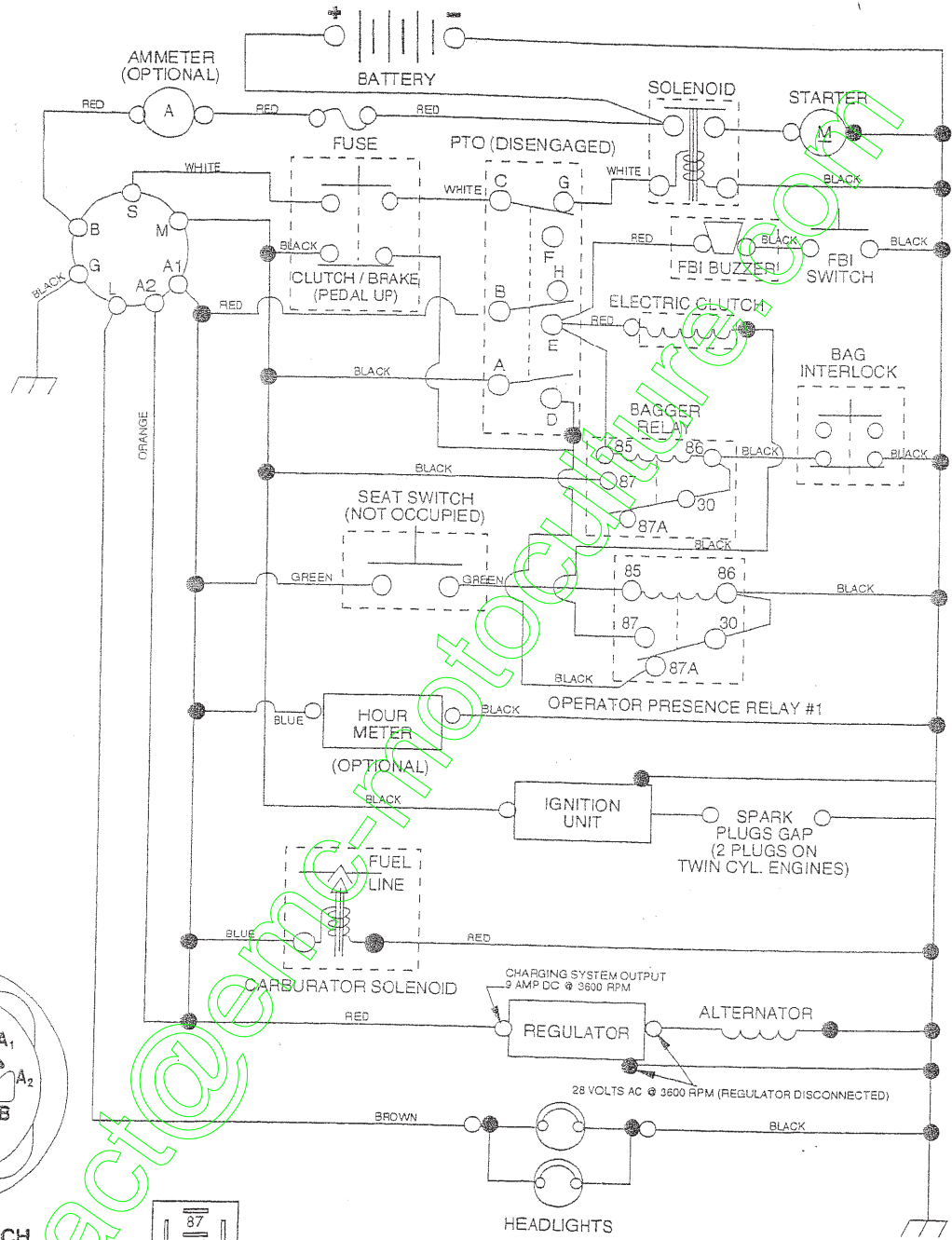

IGNITION SWITCH

POSITION	CIRCUIT	"MAKE"
OFF	M+G+A1	NONE
RUN/LIGHT	B+A1	A2+L
RUN	B+A1	NONE
START	B+S+A1	NONE

WIRING INSULATED CLIPS
 NOTE: IF WIRING INSULATED CLIPS WERE REMOVED FOR SERVICING OF UNIT, THEY SHOULD BE REPLACED TO PROPERLY SECURE YOUR WIRING.

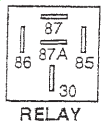

RELAY

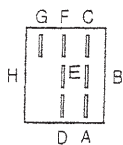

PTO SWITCH

POSITION	CIRCUIT
OFF	C+G, B+H
ON	C+F, B+E, A+D

NON-REMOVABLE CONNECTIONS

REMOVABLE CONNECTIONS

REPAIR PARTS

TRACTOR - MODEL NO. 917. 259463

ELECTRICAL

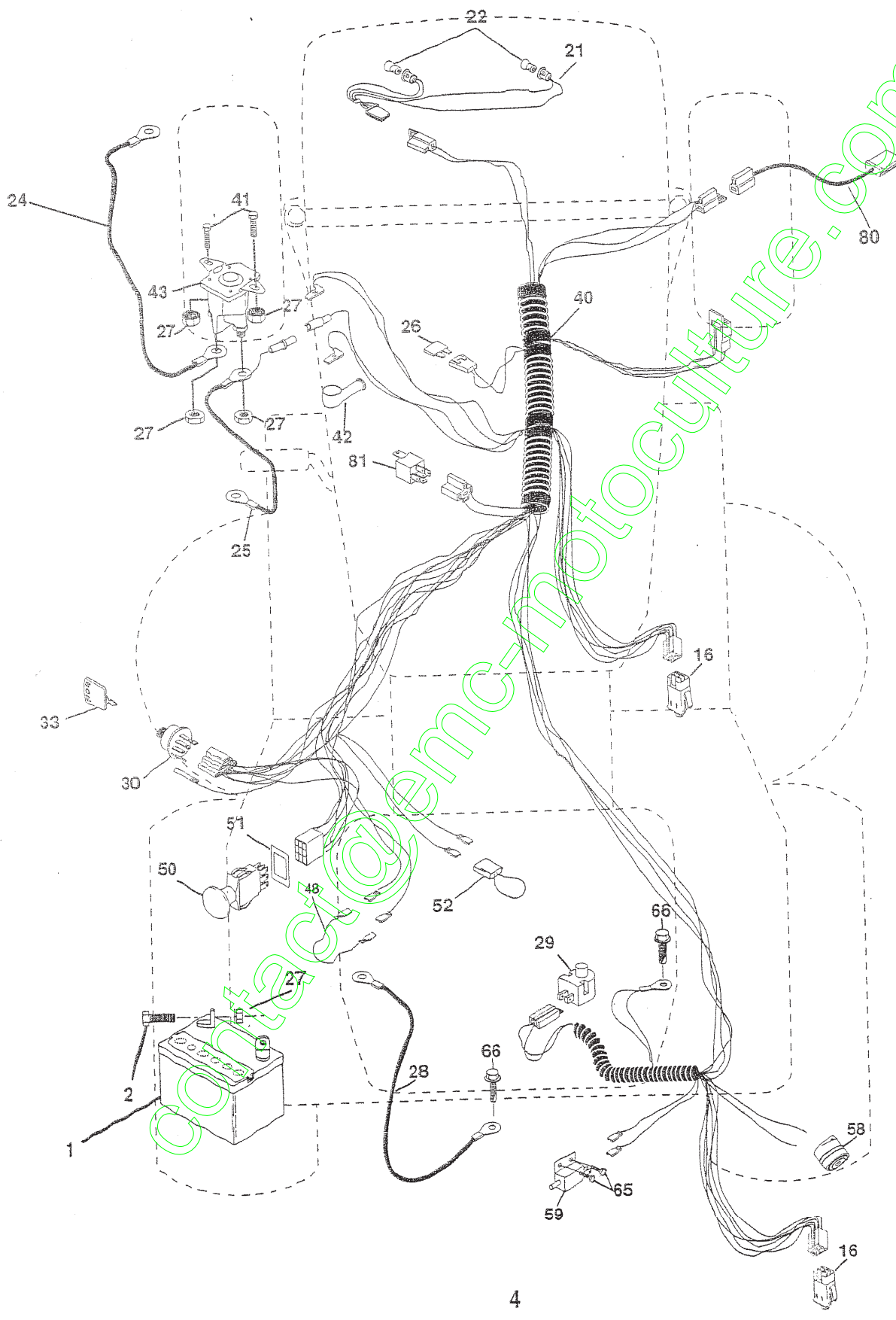

REPAIR PARTS

TRACTOR- -MODEL NO. 917. 259463

ELECTRICAL

KEY NO.	PART NO.	DESCRIPTION
1	144925	Battery 12 Volt 25 AMP Wet
2	74760412	Bolt Hex Hd 1/4-20 Unc X 3/4
16	153664	Switch Interlock Push-In
21	166182	Harness Asm Light W/4152J
22	4152J	Bulb Light #1 156
24	4799J	Cable Starter 6Ga 11" Red
25	165987	Cable Battery Crd 56" Red
26	175158	Fuse 20 Amp
27	73510400	Nut Keps Hex 1/4-20 Unc
28	127725X	Cable Ground 6Ga 18" Black
29	160784	Switch Plunger Normal Op Olive
30	175566	Switch Ignition
33	140403	Key Ign
40	170214	Harness Ign Crd Elect
41	71110408	Bolt Flk Fin Hex 1/4-20 Unc X 1/2
42	131563	Cover Terminal Red
43	175141	Solenoid
48	140844	Adapter Ammeter Rectangular
50	174652	Switch PTO
51	140405	Ring Retainer PTO
52	141940	Protection Wire Loop
58	169419	Buzzer Crd
59	166299	Switch FBI CRD
65	17211008	Screw Slftp #10-16 x 1/2 Ty-Ab
66	17490608	Screw Thdrol 3/8-16 x 1/2 Ty-Tt
80	146685	Harness Clutch EVX
81	109748X	Relay Asm

NOTE: All component dimensions given in U.S. inches.
1 inch = 25.4 mm.

REPAIR PARTS

TRACTOR- -MODEL NO. 917.259463

CHASSIS AND ENCLOSURES

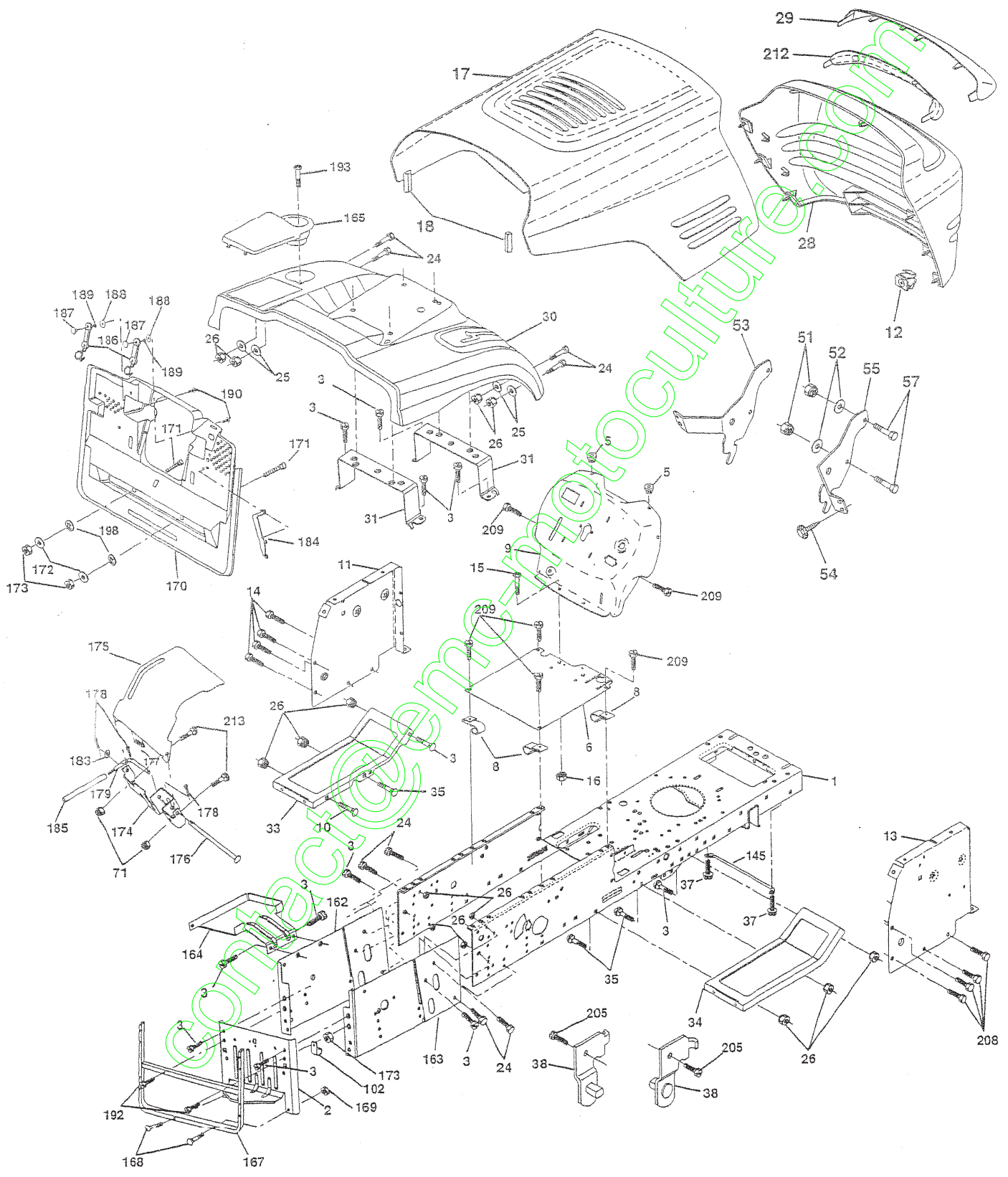

REPAIR PARTS

TRACTOR- -MODEL NO. 917.259463

CHASSIS AND ENCLOSURES

KEY NO.	PART NO.	DESCRIPTION	KEY NO.	PART NO.	DESCRIPTION
1	169831	Chassis	145	156524	Rod Pivot Chassis/Hood
2	165606	Drawbar	162	170256	Bracket Exten Chassis Lh CRD
3	17060612	Screw 3/8-16 x 3/4	163	175770	Bracket Exten Chassis Rh CRD
5	155272	Bumper Hood/Dash	164	165605	Support Battery CRD
6	155923	Saddle	165	165742X428	Cover Battery CRD Lt
8	126471X	Clip Insulator 13/32 Mtg. Hole	167	165779	Support Asm. Backplate WLD MNT
9	168350X011	Dash	168	72050412	Bolt, RDHD SHT NK 1/4-20 x 1-1/2
10	72140608	Bolt, Carriage 3/8-16 x 3/4	169	123976X	Nut, Lock 1/4 LGE FLG Gr. 5 Zinc
11	155927	Panel, Dash, L.H.	171	72140620	Bolt Hex 3/8-16 x 2-1/2 Gr 5
12	145660	Clip, Tinnerman Grille P/L	170	175264	Cover, Backplate Plastic Black
13	172108	Panel, Asm. Dash R.H.	172	19132016	Washer 13/32 x 1-1/4 x 16 Ga.
15	74180512	Screw, Machine, Truss Head 5/16-18 UNC x 3/4	173	73510600	Nut, Keps Hex 3/8-16 UNC
16	73510500	Nut	174	165939	Bracket Switch FBI CRD
17	144983X558	Hood Assembly	175	166212	Guard Door Rear CRD
18	126938X	Bumper Hood	176	128600	Pin Hinge Pivot
24	74780616	Bolt	177	132796	Spring Bagger Top LH Black
25	19131312	Washer 13/32 x 13/16 x 12 Gauge	178	76020312	Pin Cotter 3/32 x 3/4 Cad Zinc
26	73800600	Nut	179	165942	Rod Pivot FBI CRD
28	156725X558	Grille PL	183	19131316	Washer 13/32 x 13/16 x 16 Ga.
29	155217X599	Lens, Grille	184	174662	Bracket Actuator Bagger CRD
30	170139X558	Fender	185	165940	Tube Lever Switch FBI CRD
31	165156	Bracket, Fender Support	186	160793	Latch Asm Mulch/Bagger
33	145244X558	Footrest, L.H.	187	2029J	Nut Weld .327/.304 #10-24
34	145243X558	Footrest, R.H.	188	19061216	Washer #10
35	72110606	Bolt	189	10071000	Washer Lock #10
37	17490508	Screw Thdrol 5/16-18 x 1/2 TYT	190	71081010	Screw Truss Hd Phil 10-24 x 5/8
38	169834	Bracket Asm Pivot Mower Rear	193	17070412	Screw Truss 1/4-20 x 3/4
51	73800400	Nut Lock w/Insert 1/4-20 UNC	192	17060624	Screw Thdrol 3/8-16 x 1-1/2
52	19091416	Washer 9/32 x 7/8 x 16 Ga.	198	168937	Nut, Push
53	145201	Bracket, Grille LH	205	17490608	Screw Thdrol 3/8-16 x 1/2
54	161464	Screw Hex WSHD 8-18 x 7/8	208	17670608	Screw Thdrol 3/8-16 x 1/2
55	145202	Bracket, Grille RH	209	17000612	Screw Hex Wsh Thdrol 3/8-16
57	74780412	Bolt, Fin Hex 1/4-20 UNC x .75	212	165919	Insert Lens Reflect
71	73680400	Nut Crownlock 1/4-20	213	72110406	Bolt Carr
102	2751R	Clip line Fule 13/32 Mtg Hole	--	5479J	Plug, Button

NOTE: All component dimensions given in U.S. inches
1 inch = 25.4 mm.

REPAIR PARTS

TRACTOR- -MODEL NO. 917.259463

DRIVE

KEY NO.	PART NO.	DESCRIPTION	KEY NO.	PART NO.	DESCRIPTION
1	-----	Transaxle (Order part from transaxle manufacturer)	78	121748X	Washer 25/32 x 1-5/8 x 16 Gauge
		Hydro Gear Model 321-0510	81	170006	Shaft Asm. Cross
8	165619	Rod Shift Fender Adjust	82	123782X	Spring Torsion
9	167162	Clutch Elect Evx	83	19171216	Washer 17/32 x 3/4 x 16 Ga.
10	76020416	Pin Cotter 1/8 x 1 CAD	84	170007	Link Transaxle
14	10040400	Washer Lock Hvy Helical	95	170015	Rod Bypass CRD
15	74490544	Bolt Hex 5/16-18 Gr. 5	96	4497H	Retainer Spring 1" Zinc/Cad
16	73800500	Nut Lock Hex W/Ins 5/16-18 Unc P	120	73900600	Nut Lock Fig 3/8-16unc
19	73800600	Nut Lock Hex W/Ins 3/8-16	144	19111016	Washer 11/32 x 5/8 x 16 Ga.
21	130564	Knob	150	165850	Bushing Bellcrank
22	170137	Rod, Brake Hydro	151	19133210	Washer 13/32 x 2 x 10 Ga.
23	171258	Bracket Asm	153	74760516	Bolt Hex Hd 5/16-18 UNC x 1
24	73350600	Nut Hex Jam 3/8-16	156	166002	Washer Srted 5/16ID x 1.125
25	106888X	Spring, Brake Rod	158	165589	Bracket Shift Mount
26	19131316	Washer 13/32 x 13/16 x 16 Ga.	159	165494	Hub Tapered Flange Shift Lt
27	76020412	Pin Cotter 1/8 x 3/4 CAD.	160	19292016	Washer 29/32 x 1-1/4 x 16 Ga
28	145204	Rod, Parking Brake	161	72140406	Bolt Rdhd Sqnk 1/4-20 x 3/4 Gr. 5
29	71673	Cap, Parking Brake	162	73680400	Nut Crownlock 1/4-20 Unc
30	169592	Bracket, Transaxle	163	74780416	Bolt Hex Fin 1/4-20 Unc x 1 Gr 5
32	74760512	Bolt Hex Hd 5/16-18 Unc x 3/4	164	19091010	Washer 5/8 x .281 x 10 Ga
33	72140506	Bolt Rdhd Sqnk 5/16-18 unc x 3/4	165	165623	Bracket Pivot Lever
34	165496	Shaft, Foot Pedal	166	166880	Screw 5/16-18 x 5/8
35	120183X	Bearing, Nylon	167	165588	Bracket Support Shift CRD
36	19211616	Washer 21/32 x 1 x 16 Ga	168	165492	Bolt Shoulder 5/16-18 x .561
37	1572H	Pin, Roll	169	165580	Plate Fastening Cross Shf. Stlt/CR
38	165936	Pulley, Flat, Composite	171	17490608	Screw Thdrol 3/8-16 x 1/2
39	74760644	Bolt Fin Hex 3/8-16 x 2 3/4	172	170271	Shaft Asm Shifter Frt CRD
40	4470J	Spacer, Split	174	10090400	Washer Lock 1/4
42	19131312	Washer 13/32 x 13/16 x 12 Gauge	177	165932	Keeper Flat Idler
47	127783	Pulley, Idler, V-Groove	178	165933	Keeper Belt Idler
48	154407	Bellcrank Assembly	179	120958X	Washer Sintered
49	123205X	Retainer, Belt	180	165630	Pulley Flat Idler
50	74760624	Bolt Hex Hd 3/8-16 x 1-1/2	181	165797	Bracket Idler Ground Drive CRD
51	73680600	Nut Crownlock 3/8-16 UNC	182	165634	Keeper Belt 2.5"OD V-Idler CRD
52	73680500	Nut Crownlock 5/16-18 UNC	183	165626	Pulley V-Idler 2.50"OD CRD
53	105710X	Link, Clutch	184	17490644	Scr Hexwsh Thdrol 3/8-16 x 2-3/4
55	105709X	Spring, Return, Clutch	185	170008	Link shift CRD Hydro
56	74760620	Bolt Fin Hex 3/8-16 UNC x 1-1/4	186	165614	Hub Tapered Round CRD
57	170140	V-Belt, Ground Drive	187	17060620	Screw Thdrol 3/8-16 x 1-1/4
61	17060612	Screw 3/8-16 x 3/4	188	110436X	Bushing Snap Split
62	8883R	Cover, Pedal	197	169613	Nyliner Snap-In 5/8" ID
63	145868	Pulley, Engine	199	169612	Bolt Shoulder 5/16-18unc
65	10040700	Washer	200	72140508	Bolt RDHD SQNK 5/16-18unc x 1
66	154778	Keeper Belt Engine	202	72110612	Bolt Carr Sh 3/8-16 x 1-1/2 Gr. 5
71	169183	Strap Torque Lh Hydro	203	71170780	Bolt, Hex 7/16-20 x 5
73	169182	Strap Torque Rh Hydro	206	19131416	Washer 13/32 x 7/8 x 16
74	137057	Spacer, Split	207	169845	Washer Nylon Rear
75	121749X	Washer 25/32 x 1-1/4 x 16 Gauge	208	169844	Bracket Idler Rear LH CRD
76	12000001	E-Ring	209	72110606	Bolt RDHD SHT SQNK 3/8-16 x 3/4
77	123583X	Key, Square			

NOTE: All component dimensions given in U.S. inch
1 inch = 25.4 mm

REPAIR PARTS

TRACTOR- -MODEL NO. 917.259463

STEERING ASSEMBLY

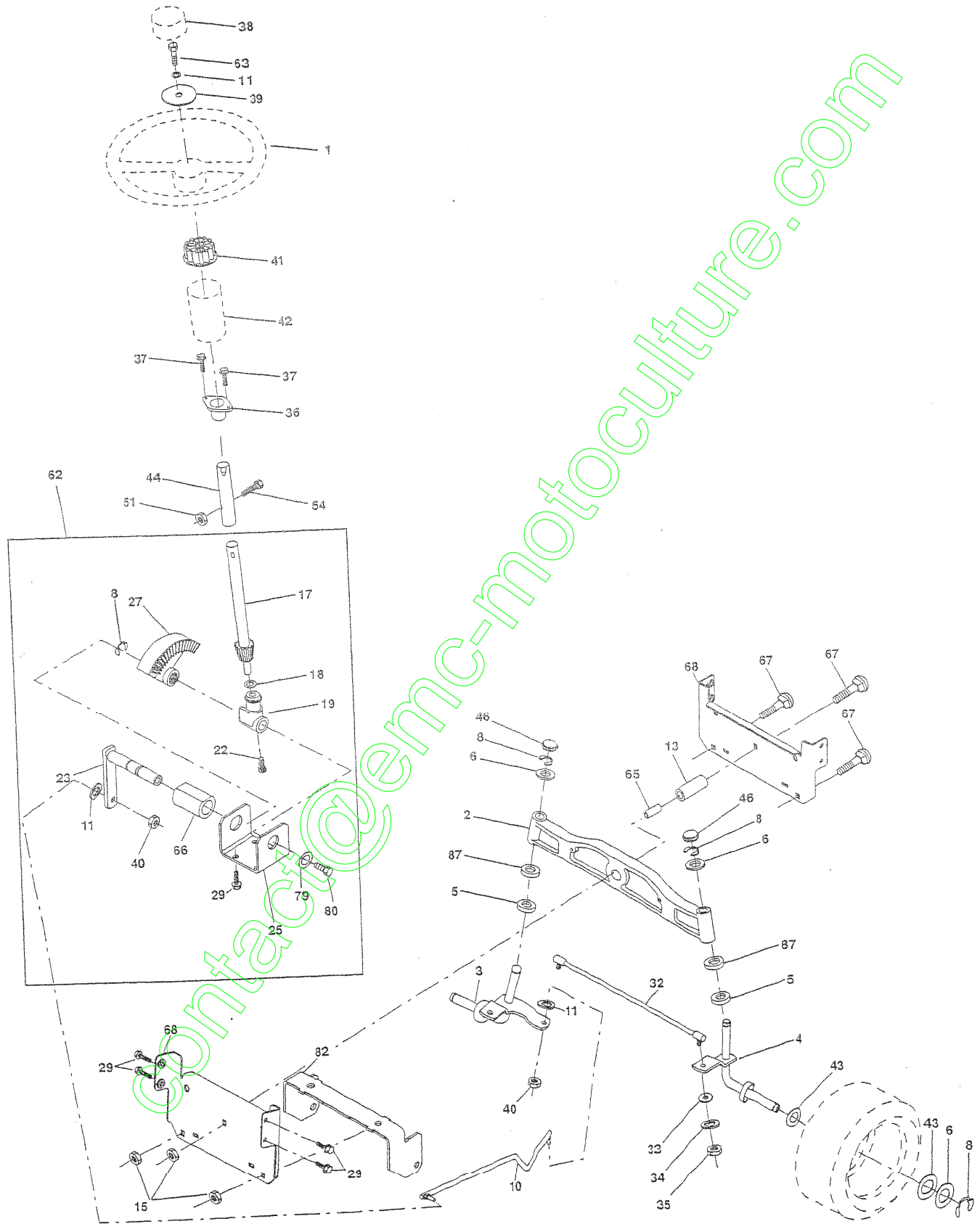

REPAIR PARTS

TRACTOR- -MODEL NO. 917.259463

STEERING ASSEMBLY

KEY NO.	PART NO.	DESCRIPTION
1	139768	Steering Wheel
2	172393	Axle Cast Lt Machined
3	169840	Spindle Assembly, L.H.
4	169839	Spindle Assembly, R.H.
5	6266H	Bearing, Race, Thrust, Hardened
6	121748X	Washer 25/32 x 1-5/8 x 16 Gauge
8	1200029	Ring, Klip
10	169832	Link, Drag
11	10040600	Washer, Lock
13	136518	Spacer Brg Axle Front
15	145212	Nut, Hex Flange Lock
17	156546	Shaft Assembly, Steering
18	57079	Washer, Thrust .515 x .750 x .033
19	160395	Support, Shaft
22	165857	Screw Hex Wshhd Torx
23	165851	Pittman Shaft Assembly
25	154406	Bracket, Steering
27	136874	Gear, Sector
29	17060612	Screw, 3/8-16 x 3/4
32	171888	Rod, Tie
33	19111216	Washer 11/32 x 3/4 x 16
34	10040500	Washer Lock Hvy HLCL SPR 5/16
35	73540500	Crownlock Nut 5/16-24
36	155099	Bushing, Steering
37	152927	Screw T ₁ #10-32 x 5 x 3/8 Flange
38	139769	Cap Wheel Steering
39	19133812	Washer 13/32 x 2-3/8 x 12 Gauge
40	7810H	Nut Lock Center 3/8-24 Unf
41	100711L	Adaptor, Steering Wheel
42	145054X428	Boot, Steering Dash P/L Mtl
43	121749X	Washer 25/32 x 1-1/4 x 16 Gauge
44	153720	Extension Steering Non-Adjust
46	121232X	Cap, Spindle
51	73800500	Nut Lock Hx W/Ins 5/16-18 UNC
54	74780520	Bolt Fin Hex 5/16-18 UNC x 1-1/4
62	167902	Kit, Steering Assembly, Service
63	74780616	Bolt Fin Hex 3/8-16 unc. x 1 Gr. 5
65	160367	Spacer Brace Axle
66	154404	Bearing Arm Pittman
67	72140618	Bolt Rdhd Sqnk 3/8-16 x 2-1/4
68	169827	Brace Axle
79	19132012	Washer 13/32 x 1-1/4 x 12 Ga
80	74950612	Bolt Hex Nylon 3/8-16 x 3/4
82	169835	Bracket Susp Chassis Front
87	173966	Washer Flat .781 x 1-1/2 x .14

NOTE: All component dimensions given in U.S. inches.
1 inch = 25.4 mm.

REPAIR PARTS

TRACTOR- -MODEL NO. 917.259463

SEAT ASSEMBLY

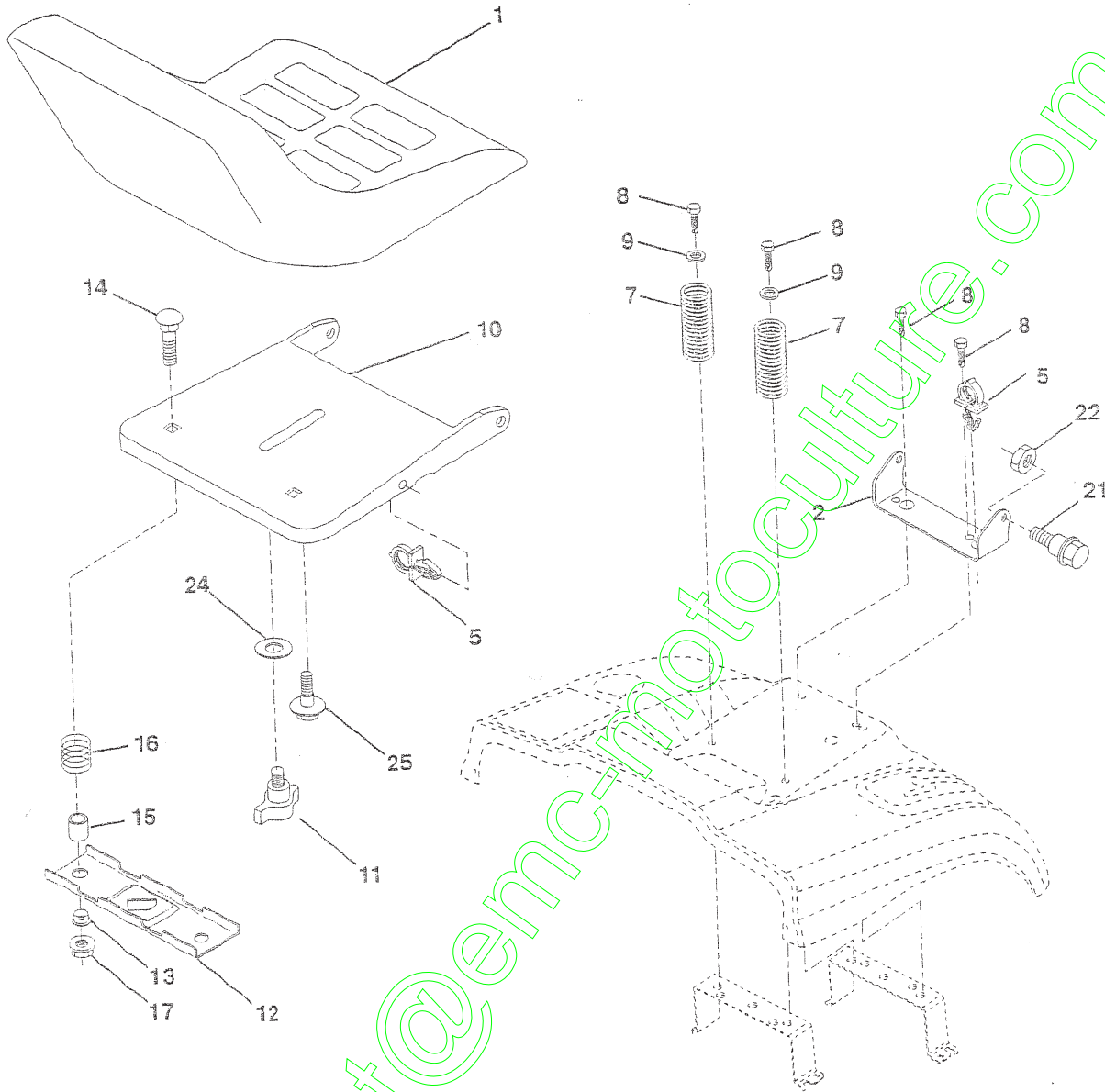

KEY NO.	PART NO.	DESCRIPTION
1	140123	Seat
2	140551	Bracket Pnt Pivot Seat (blk)
5	145006	Clip Push In Hinged
7	124181X	Spring Seat Cprsn 2 250 Blk Zi
8	17000616	Screw 3/8-16 X 1-1/2
9	19131614	Washer 13/32 X 1 X 14 Ga
10	174894	Pan Pnt Seat (blk)
11	166369	Knob Seat Adj Wingnut
12	121246X	Bracket Pnt Mounting Switch
13	121248X	Bushing Snap Blk Nyl 50 Id

KEY NO.	PART NO.	DESCRIPTION
14	72050412	Bolt Rdhd Sht Nk 1/4-20x1-1/2
15	134300	Spacer Split .28 X .96 Zinc
16	121250X	Spring Cprsn
17	123976X	Nut Lock 1/4 Lge Flg Gr 5 Zinc
21	171852	Bolt Shoulder 5/16-18 Unc-2A
22	73800500	Nut Hex Lock w/Ins 5/16-18
24	19171912	Washer 17/32 X 1-3/16 X 12 Ga.
25	127018X	Bolt Shoulder 5/16-18 X 62

NOTE: All component dimensions given in U.S. inches.
1 inch = 25.4 mm

REPAIR PARTS

TRACTOR- -MODEL NO. 917.259463

DECALS

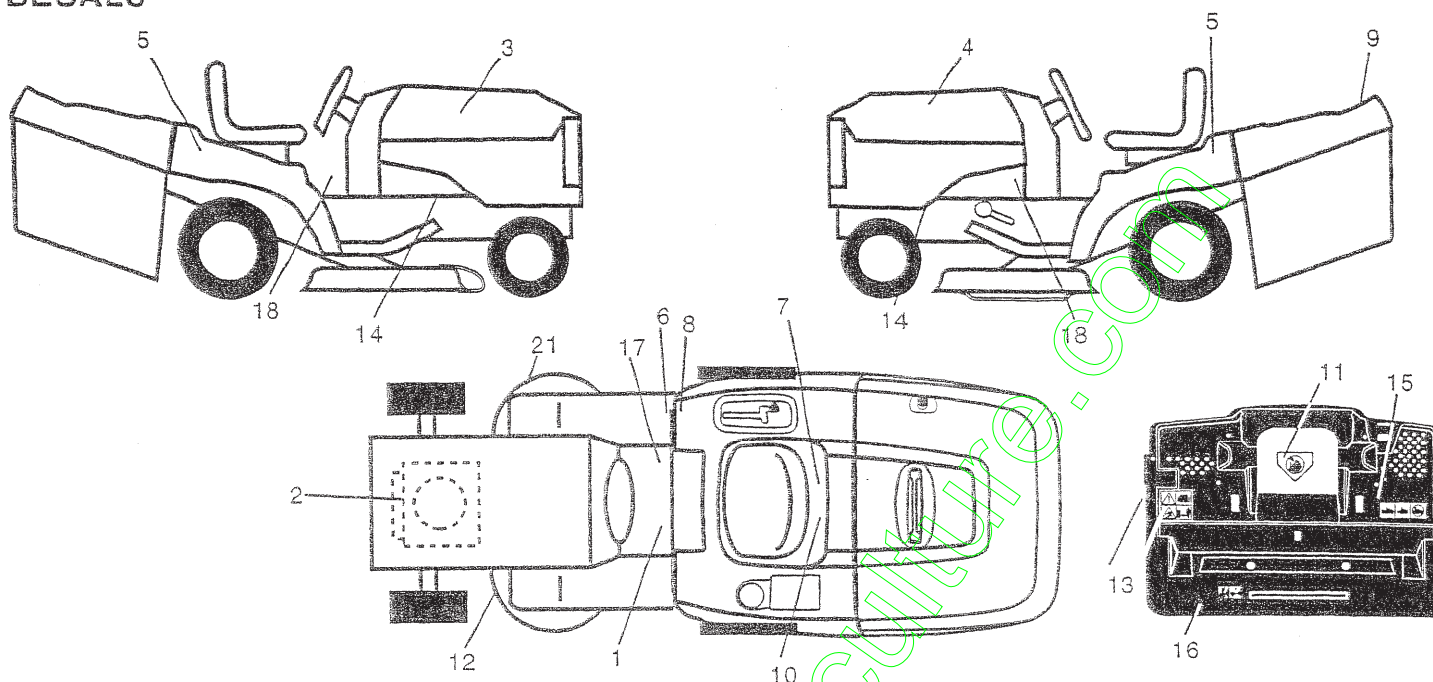

KEY NO.	PART NO.	DESCRIPTION
1	145498	Decal Read Owner's Manual Sym
2	165404	Decal Hp Engine
3	171696	Decal Hood Rh
4	171697	Decal Hood Lh
5	168322	Decal Fend Auto
6	126187X	Decal 100 DBA
7	166960	Decal Bypass Fender
8	145437	Decal Europe Stand Ce
9	163204	Decal Fender
10	145005	Decal Bat Dan/Poi P/L Sym Wpr
11	145494	Decal Mower Cut Finger Symbol
12	159737	Decal Brake/Clutch Symbol Lt

KEY NO.	PART NO.	DESCRIPTION
13	166959	Decal Warn Back Plate CRD
14	159736	Decal Chassis Hot Muffler
15	166961	Decal Oper Bag Presence CRD
16	162598	Decal Drawbar Load Limit
17	140837	Decal Saddle Brake Parking
18	163252	Decal, Dash Panel
21	166286	Decal Deck Sch 92 CRD
--	138311	Decal Lift Handle
--	157199X428	Pad, Footrest
--	178033	Manual Operator's (Euro)
--	178034	Manual Operator's (Scand)
--	178015	Manuai Parts

WHEELS & TIRES

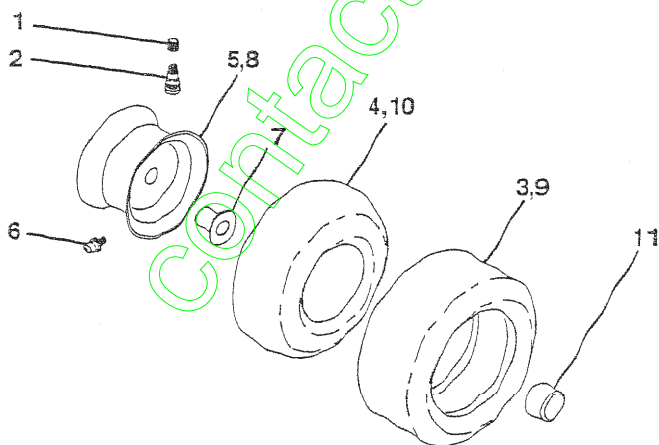

KEY NO.	PART NO.	DESCRIPTION
1	59192	Cap Value Tire
2	65139	Stem Value
3	106222X	Tire F Ts 15 X 6 0 - 6 Service
4	59904	Tube Inner Front #35060
5	106732X427	Rim Asm 6"front White Service
6	278H	Fitting Grease
7	9040H	Bearing Flange
8	106108X427	Rim Asm 8" rear White Service
9	138468	Tire R Ts 20 x 8-8 Service
10	7152J	Tube Rear 9 5 X 8 Service
11	104757X428	Cap Axle Blk 1 50 X 1 00
--	144334	Sealant, Tire (10 oz. tube)

NOTE: All component dimensions given in U.S. inches
1 inch = 25.4 mm

PAIR PARTS

TRACTOR- -MODEL NO. 917.259463

INE

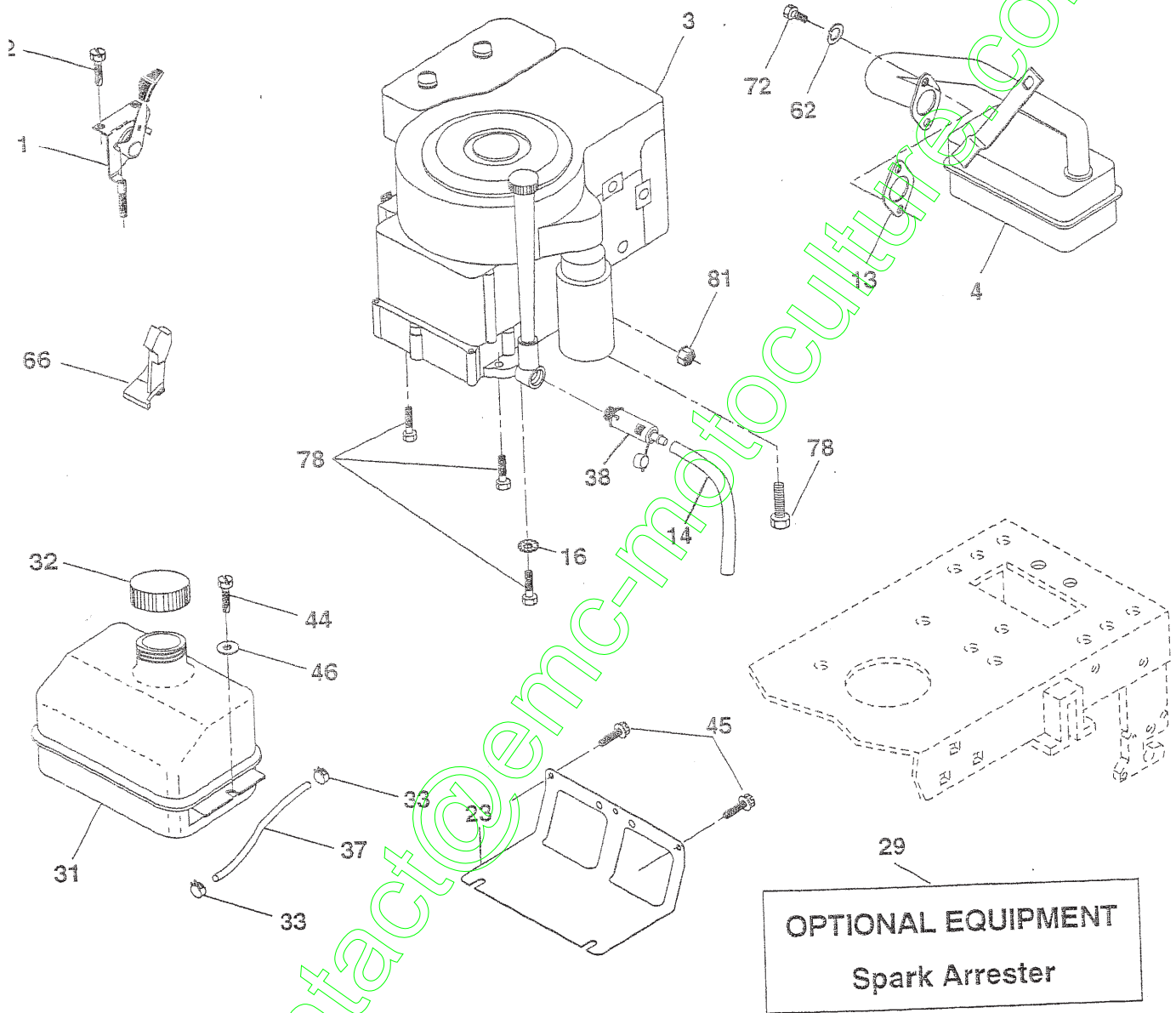

REPAIR PARTS

TRACTOR- -MODEL NO. 917.259463

ENGINE

KEY NO.	PART NO.	DESCRIPTION
1	170549	Control Throt/Ch Lh
2	17720410	Screw Hex Thd Cut 1/4-20x5/8 T
3	-----	Engine Briggs Model 28U707-1175-E3
4	137352	Muffler Exhaust B&S Lt
13	165291	Gasket 1 313 Id Tin Plated
14	148456	Tube Drain Oil Easy
16	11050600	Washer Lock Ext Tooth 3/8
23	169837	Shield Browning/Debris Guard
29	137180	Arrestor Spark
31	109202X	Tank Fuel 1.25 Fr
32	158990	Cap Asm Fuel
33	123487X	Clamp Hose Blk
37	137040	Line Fuel 20"
38	148315	Plug Drain Oil Easy
44	17670412	Screw Hexwsh Thdrol 1/4-20x3/4
45	17000612	Srew 3/8-16 x 3/4
46	19091416	Washer 9/32 X 7/8 X 16ga
62	10040500	Washer Lock Hvy Hlcl Spr 5/16
66	127951	Stop Throttle 3000 Rpm
72	71070512	Screw Hexhd Cap 5/16-18x3/4
78	17060620	Screw 3/8-16x1-1/4
81	73510400	Nut Flange 1/4-20 Starter Nut

NOTE: All component dimensions given in U.S. inches
1 inch = 25.4 mm

PAIR PARTS

TRACTOR- -MODEL NO. 917.259463

WER LIFT

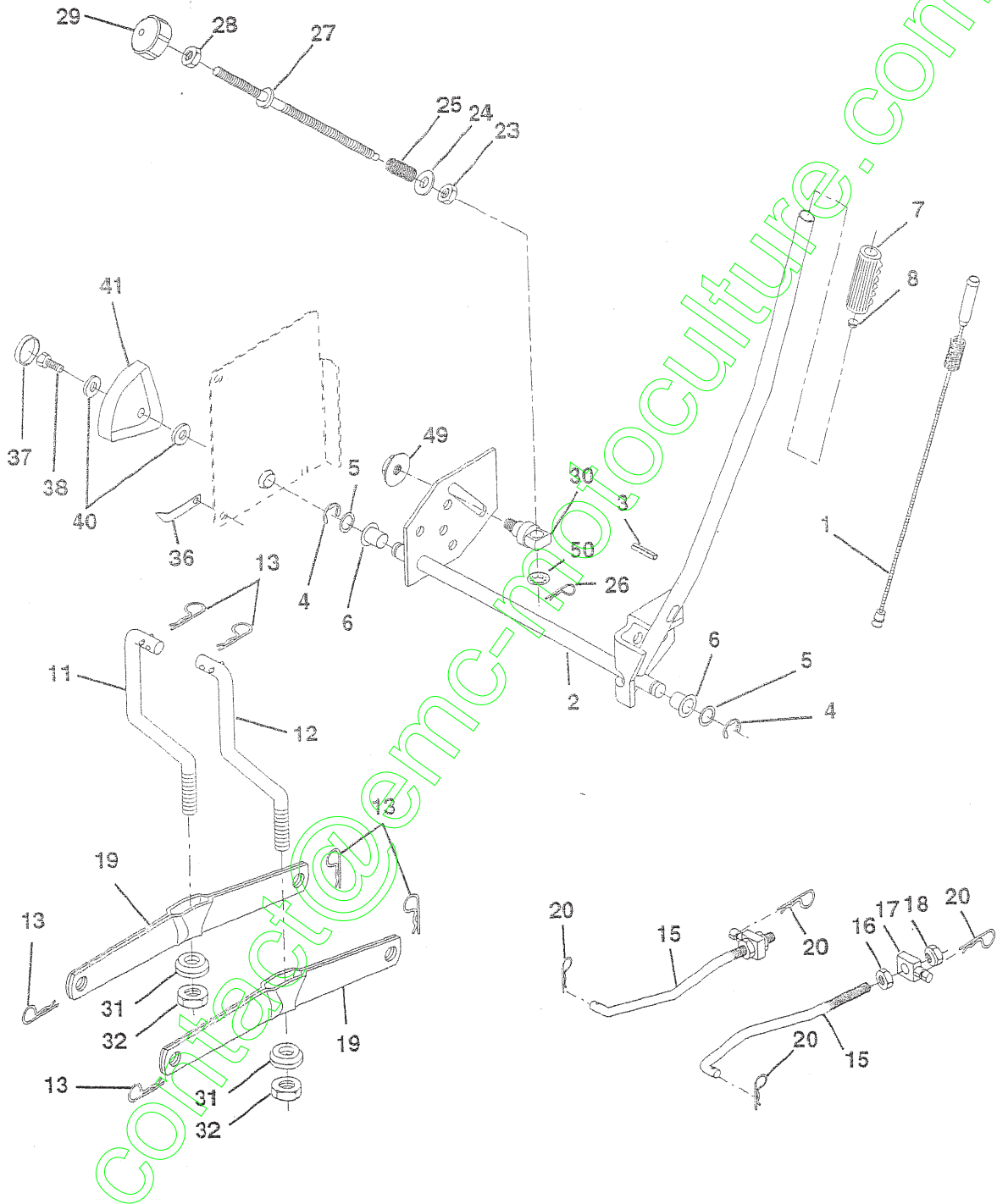

REPAIR PARTS

TRACTOR- -MODEL NO. 917.259463

MOWER LIFT

KEY NO.	PART NO.	DESCRIPTION
1	159460	Washer Asm Inner Spring W/Plunger
2	159471	Shaft Asm. Lift
3	105767X	Pin Groove
4	12000002	E Ring #5133-62
5	19211621	Washer 21/32 x 1 x 21 Ga.
6	120183X	Bearing Nylon
7	125631X	Grip Handle Fluted
8	122365X	Button Plunger Black
11	165829	Link Asm Lift L.H.
12	165831	Link Asm Lift R.H.
13	4939M	Retainer Spring
15	173288	Link Front
16	73350800	Nut Jam Hex 1/2-13 Unc
17	130171	Trunnion Blk Zinc
18	73800800	Nut Lock W/wsh 1/2-13 Unc
19	139868	Arm Suspension Mower
20	163552	Retainer Spring
23	110807X	Nut Special
24	19131016	Washer 13/32 x 5/8 x 16 Ga.
25	2876H	Spring 2-1/8"
26	169484	Retainer Clip
27	126971X	Rod Adj Lift Zinc 7.49 Wrk Lg
28	73350600	Nut Hex Jam 3/8-16 Unc
29	138057	Knob Inf 3/8-16 Unc Blk w/sym
30	150233	Trunnion Infin Height
31	169865	Bearing, Pvt. Lift.
32	73540600	Nut Crownlock 3/8-24
36	155097	Pointer Height Indicator
37	123935X	Plug Hole Blk 1.485/1.515 Dia
38	17060516	Screw 5/16-18 x 1
40	19112410	Washer 11/32 x 1-1/2 x 10 Ga.
41	123934X	Scale Ind Height Blk
49	145212	Nut hex Flange Lock
50	140452X	Nut Push Phos & Oil

NOTE: All component dimensions given in U.S. inches
1 inch = 25.4 mm

PAIR PARTS

TRACTOR- -MODEL NO. 917.259463

VER

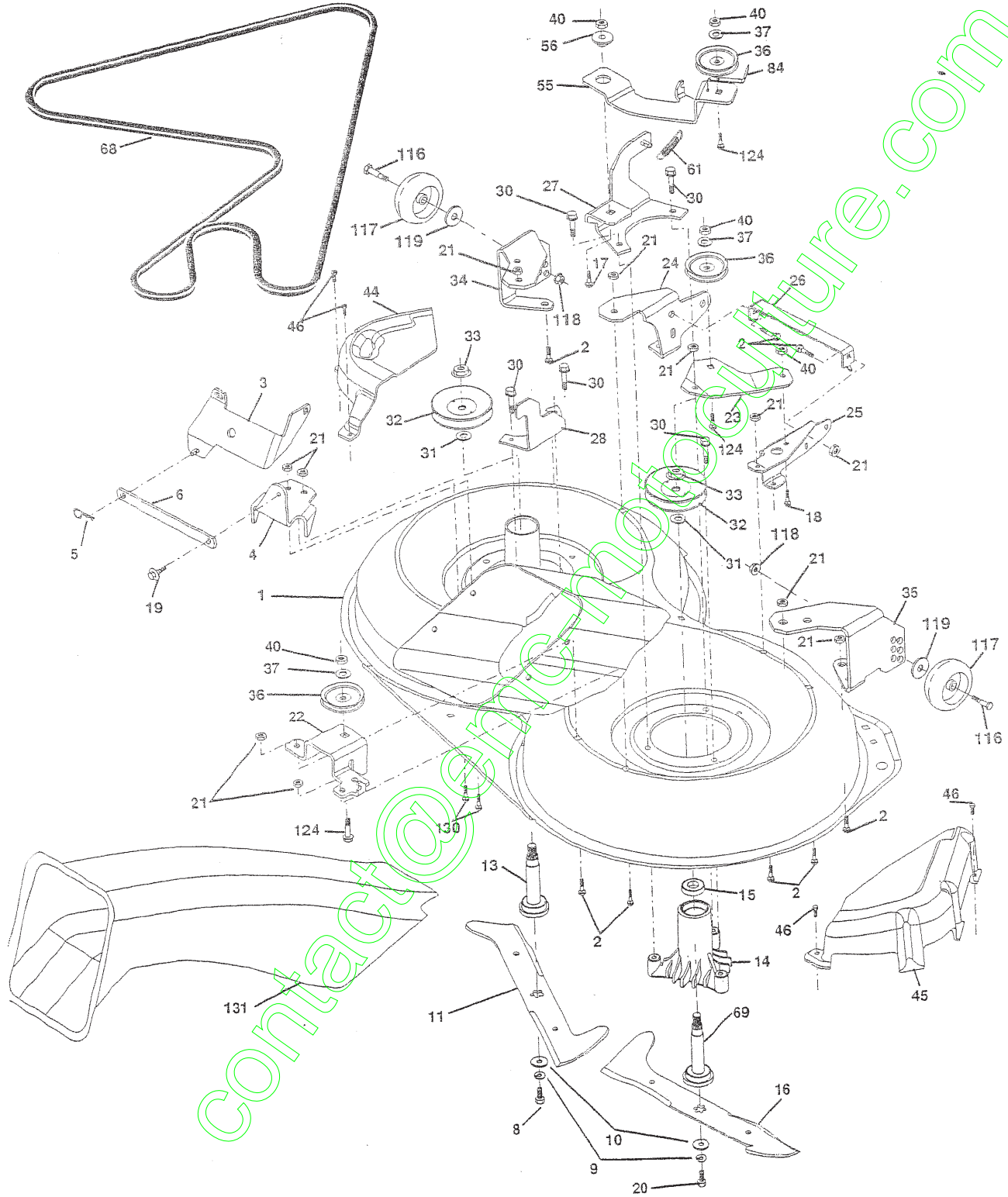

REPAIR PARTS

TRACTOR- -MODEL NO. 917.259463

MOWER

KEY NO.	PART NO.	DESCRIPTION	KEY NO.	PART NO.	DESCRIPTION
1	165552	Housing Asm. Mower 92 CRD	32	153531	Mandrel Pulleys 36 & 46
2	72140506	Bolt Rdhd Sqnk 5/16-18 Unc x 3/4	33	137266	Nut Flg Top Lock Cntr B 9/16
3	165569	Bracket Asm. S-Bar Chass 92 CRD	34	165239	Bracket Gauge Wheel Lf 92 CRD
4	165558	Bracket Bar Sway Deck 92 CRD	35	165238	Bracket Gauge Wheel Rf 92 CRD
5	4939M	Retainer Spring	36	146763	Pulley Idler V-Groove Dim 4.25
6	165557	Bar Sway 92 CRD	37	19131316	Washer 11/32 x 13/16 x 16 Ga
8	850857	Bolt 3/8-24 x 1.25 Gr8 Patched	40	73680600	Nut Crownlock 3/8-16 Unc
9	10030600	Washer Lock Hvy 3/8 Unplated	44	165724	Cover Mandrel Lh 92 CRD
10	140296	Washer Hard Blade Mower vented	45	165556	Cover Mandrel Rh 92 CRD
11	170037	Blade 3-1 Lh	46	137729	Screw Thd Roll 1/4-20 x 5/8
13	137645	Shaft Asm. W/Lower Bearing	55	165445	Arm Idler 92 CRD
14	128774	Housing Mandrel Vented (Machd)	56	165723	Spacer Retainer Mower
15	110485X	Bearing Ball Mandrel	61	165945	Spring Tension Belt
16	170038	Blade 3-1 Rh	68	165555	Hex-Belt 92 Mower 105AA
17	72140610	Bolt Carriage 3/8-16 x 1-1/4	69	165482	Shaft Asm W/Lwr Brg Rh Thd CRD
18	72110608	Bolt Rdhd Sqnk 3/8-16 x 1 Gr5	84	156085	Keeper Belt Idler
19	132827	Bolt Shoulder 5/16-18 Thd Form	116	137644	Bolt Shoulder
20	165484	Bolt 3/8-24 x 1.25 Gr8 Ptch Lhthd	117	133957	Wheel Gage
21	73680500	Nut Crown Lock 5/16-18	118	73930600	Nut Centerlock 3/8-16 Unc
22	165243	Bracket Idler Sprt RR 92 CRD	119	19121414	Washer 3/8 x 7/8 x 14 Ga.
23	165446	Bracket Idler Sprt RF 92 CRD	124	72110612	Bolt Carr Sh 3/8-16 x 1-1/2 Gr5
24	165242	Bracket Suspension LF 92 CRD	130	72110506	Bolt Rdhdsqnk 5/16-18 Unc x 3/4
25	165244	Bracket Suspension RF 92 CRD	131	165661	Chute Bagger CRD 92cm
26	165237	Brace Support Susp Frt CRD	-	130794	Mandrel Asm Service
27	165568	Bracket Asm. Susp RR 92 CRD	-	165579	Mandrel Asm CRD Lh Threads SVC
28	165567	Bracket Asm. Susp LR 92 CRD	-	173549	Deck Mower Complete
30	157722	Screw Thd Rolling Washer Head			
31	129963	Washer Spacer Mower Vented			

NOTE: All component dimensions given in U.S. inches
1 inch = 25.4 mm

PAIR PARTS

TRACTOR- -MODEL NO. 917.259463

SEGER

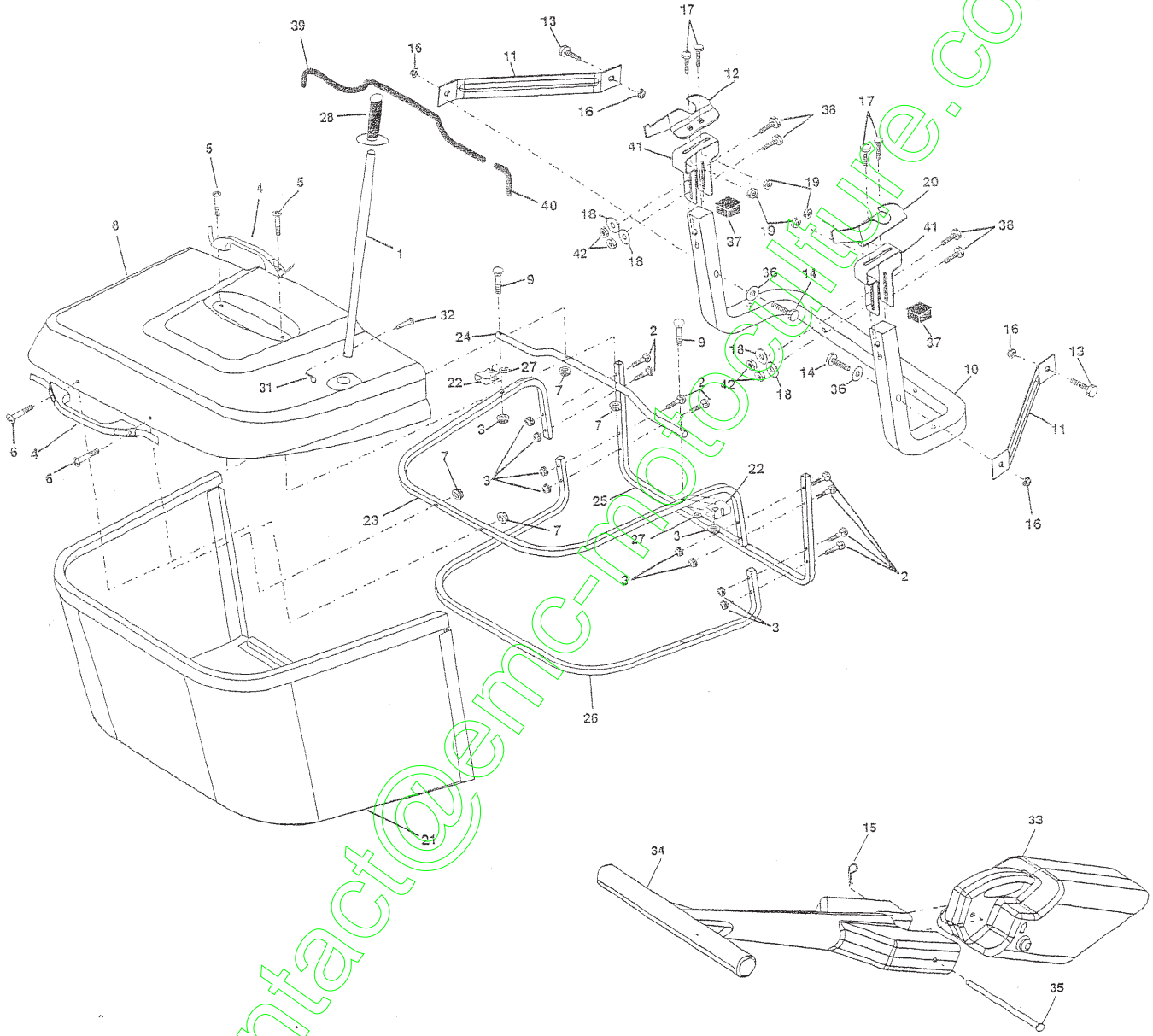

REPAIR PARTS

TRACTOR- -MODEL NO. 917.259463

BAGGER

KEY NO.	PART NO.	DESCRIPTION
1	170690	Tube Handle Bagger CRD
2	72140416	Bolt Carriage 1/4-20 x 2.0 Gr.5
3	123976X	Nut Lock 1/4 Lge Flg Gr. 5 Zinc
4	169916	Handle Bagger W/Lvrs
5	74981024	Screw Pan Head #10-24 x 1.50 BIK
6	74981032	Screw Pan Hd
7	73401000	Nut Wiz Lock Hex Serr/Hd 10-24
8	165715X558	Cover Bagger Plastic CRD
9	72140418	Bolt Carriage 1/4-20 x 2.25 Gr.5
10	169688	Tube Support Bagger CRD
11	165719	Bracket Support Upper Bag CRD
12	169685	Bracket Horiz Adj Bggr Lh CRD
13	72110606	Bolt Rdhd Sht Sqnk 3/8-16 x 3/4
14	74520640	Bolt Hex 3/8-16 x 2-1/2 Gr.5
15	493M	Retainer Spring
16	73900600	Nut Lock Flg 3/8-16 Unc
17	72140506	Bolt Rdhd Sht Sqnk 5/16 -18 Unc x 3/4
18	19111216	Washer 11/32 x 3/4 x 16 Ga.
19	73900500	Nut Lock Hex Flange 5/16-18
20	169684	Bracket Horiz Adj Bggr RH CRD
21	165780	Bag Asm CRD
22	165781	Bracket Side Bagger CRD
23	165782	Tube Upper Bagger CRD
24	165783	Tube Pivot Bagger CRD
25	165784	Tube Front Bagger CRD
26	165785	Tube Lower Bagger CRD
27	169692	Bushing Snap Bagger CRD
28	170696	Grip Handle Black
31	4497H	Retainer Spring 1" Zinc/Cad
32	126875X	Rivet Rd Hd Drilled 3/8 Dia
33	165571	Plug Mulcher
34	165570	Handle Mulcher
35	165572	Pin Mulcher
36	19132016	Washer 13/32 x 1-1/4 x 16 Ga.
37	175401	Plug Support
38	72010520	Bolt 5/16-18 x 2-1/2
39	169999	Seal.16600
40	170000	Seal.58300
41	169683	Bracket Vert Adj Bagger CRD
42	73800500	Nut Lock Hex W/Ins 5/16-18 Unc PI

NOTE: All component dimensions given in U.S. inches
1 inch = 25.4 mm

REPAIR PARTS

TRACTOR - - MODEL NUMBER 917.259463

DRO GEAR TRANSAXLE - MODEL NUMBER 321-0510

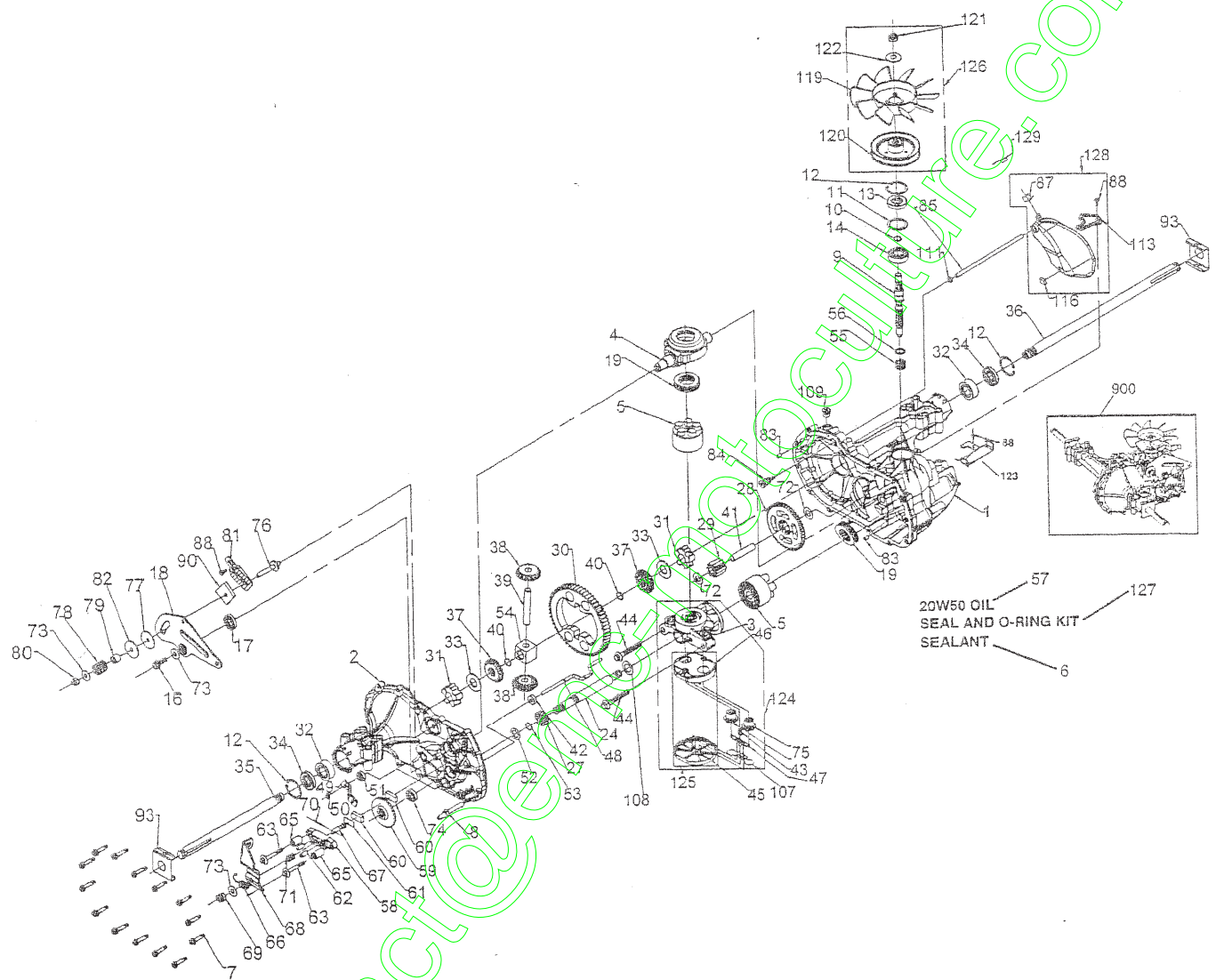

REPAIR PARTS

TRACTOR - - MODEL NUMBER 917.259463

HYDRO GEAR TRANSAXLE - MODEL NUMBER 321-0510

KEY PART NO. NO.	DESCRIPTION	KEY PART NO. NO.	DESCRIPTION
1 170351	Main Housing, Assembly	60 142883	Brake Puck
2 170352	Side Housing, Assembly	61 142882	Puck Plate
3 170353	Center Section, Assembly	62 170409	Brake Actuating Pin
4 170354	Swashplate, Trunion Machined	63 170410	HFHCS 1/4-20X2 W/Patch, Special Flange
5 169898	Block - Assembly	64 142892	Bolt, 1/4-20 X 1 W/Patch
6 170355	Sealant	65 170411	Spacer
7 170356	Hex Flange Screw 1/4-20 X 1.25	66 170412	Spring, Brake Arm Bias
8 170357	Stud, 5/16-24 Hex Double End	67 170413	SO. HD. BOLT 5/16-24-Ribbed
9 170358	Shaft, Input	68 178157	Arm, Brake
10 170359	Ring - Retaining	69 170415	Slotted Hex Nut 5/16-24
11 170360	Spacer	70 170416	Cotter Pin 3/32 X 3/4
12 169870	Ring - Retaining	71 170417	Compression Spring Brake Anti-Drag
13 170361	Seal, Lip .67 X 1.58 X .276	72 170418	Washer, HT .5 I.D. X 1 O.D. X .032
14 173158	Ball Brg 17MM ID X 40MM OD X 12MM	73 142884	Flat - Washer 1 1/32 I.D. X 7/8 O.D.
16 170362	Hex Flange Head Screw 5/16-24 X 0.75	74 170419	Oil Seal .625 X 1.0 X .25
17 170363	Lip Seal 18 X 32 X 7	75 170420	Check Plug Assembly, .027, Washer
18 170364	Arm, Control	76 170421	Stud, 5/16-24 Friction Pack
19 173159	Bearing, 30X52X13 Thrust	77 170422	Puck, .330 X 1.50 X .0975
23 170365	Check Plug Assembly, Washer	78 142969	Spring, Helical Comp
24 170366	Shaft, Motor 1	79 142980	Spacer
27 170367	Gear - Pinion, 13T	80 150778	Hex Lock Nut 5/16-24 UNJF(Nylon Insert)
28 170368	10T/48T GEAR	81 170423	Wedge, Friction Pack
29 170369	Gear, 10T Jackshaft	82 170424	Clip, Washer .316X1.50X.1046 (Plated)
30 170370	60T Bull Gear	83 161168	Pin, Standard Headless
31 170371	Sleeve Bearing .75 X 1.575 X .625	84 170425	Fitting, 5/16 Sae 5/32 Tube
32 170389	Sleeve Bearing (Outboard).75X1.750X.625	85 170426	Hose, Expansion Tank
33 142991	Washer, 3/4 ID X 1-1/2 OD X .13 THK	87 173160	Cap, Vent
34 170390	Lip Seal Axle Seal	88 170428	Bolt, Self Tapping 10-32 X 1/2
35 170391	Shaft, Axle .75 X 11.39 (Key, R.H.)	90 170430	Puck, Inner Wedge
36 170392	Shaft, Axle .75 X 16.99 (Key, L.H.)	93 170431	Spring Clip - Housing Thrust
37 150792	Miter Gear (SPLINED)	107 170432	Deflector
38 150793	Miter Gear 15T (0.5 ID)	108 170433	Washer, Motorshaft .711DX1.15ODX.030THK
39 150809	Shaft	109 170434	Plug, Sae #6
40 170393	Ring, Spiral Retaining	111 170435	O-ring .07 x .301 I.D.
41 170394	Pin, Jackshaft	113 170437	Bracket, Support Expansion Tank
42 170395	Magnet, Ring	116 170438	Silicon Sponge
43 170396	Spring, Bypass	119 178158	Fan
44 150797	Hydro mtg Screw 3/8-24 X 2.5 Long	120 178159	Pulley
45 170397	Filter	122 173162	#12 T.F. Screw-Indented Hex Washer Head
46 170398	Base, Filter	123 178160	Bracket Belt Keeper
47 170399	Actuator, Bypass	124 170444	Center Section-Filter-Bypass Assembly
48 170400	Rod, Bypass Actuator	125 170445	Filter Assembly
49 178156	Arm, Bypass	126 173164	Fan - Pulley Service Assembly
50 170402	Retaining Ring .250 External	127 170447	Seal - O-ring Kit
51 170403	Seal, Lip .741 X .250 X .250 TC	128 173165	Kit, Expansion Tank
52 170404	Flat Washer, 5/8 ID X 1.0 OD X .05 THK	900 171613	Transaxle, complete
53 170405	Retaining Ring		
54 170406	Bearing, Center Block		
55 142977	Spring - Helical Compression		
56 142978	Washer		
57 150798	20W-50 OIL 72.8oz		
58 170407	Brake Yoke		
59 170408	Rotor, Brake		

NOTE: All component dimensions given in U.S. inches 1 inch = 25.4 mm