



REPAIR PARTS MANUAL

MODEL NO. 277020

Lawn Tractor

00020734

MCAUSE 96CM EJ LATERALE



HOW TO USE THIS MANUAL

This manual is designed to provide the customer with a means to identify the parts on his/her tractor when ordering repair parts. The illustrations may or may not represent the actual assemblies; therefore, it is not recommended to use this manual as a guide to assemble or disassemble the tractor. Some hardware and parts are drawn larger in order to more readily identify them.

Each tractor has its own model number.

The model number for your tractor can be found on the fender under the seat.

When ordering parts, always give the following information:

- Product - "Tractor"
- Model Number - "277020"
- Part Number
- Part Description

TABLE OF CONTENTS

SCHEMATIC	3
ELECTRICAL	4-5
CHASSIS	6-7
DRIVE	8-9
STEERING	10-11
SEAT	12
DECALS	13
ENGINE	14-15
MOWER LIFT	16-17
MOWER DECK	18-19
TRANSAXLE	20-21
ENGINE BREAKDOWN	22-27
WARRANTY	28

SCHEMATIC

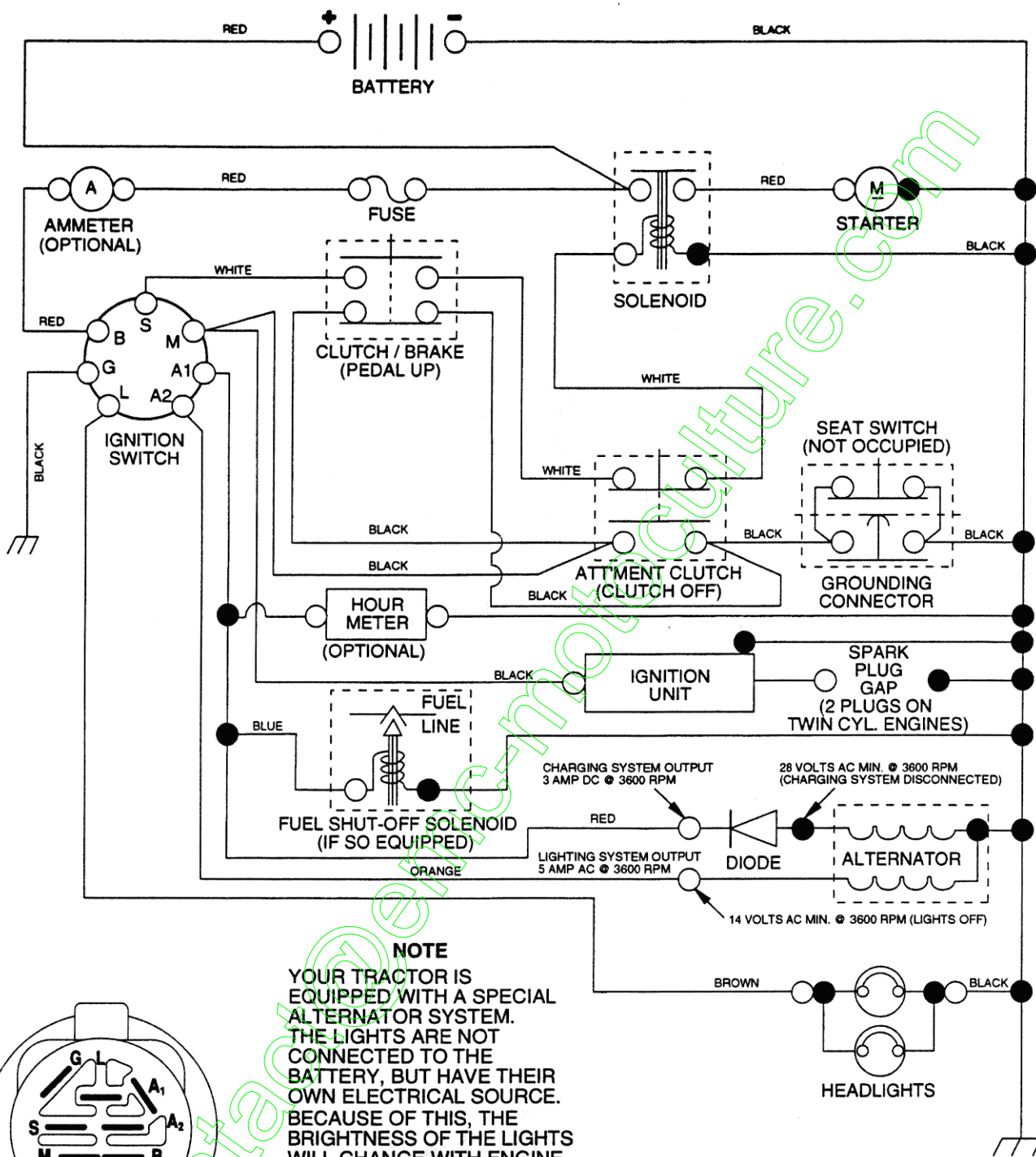

NOTE

YOUR TRACTOR IS EQUIPPED WITH A SPECIAL ALTERNATOR SYSTEM. THE LIGHTS ARE NOT CONNECTED TO THE BATTERY, BUT HAVE THEIR OWN ELECTRICAL SOURCE. BECAUSE OF THIS, THE BRIGHTNESS OF THE LIGHTS WILL CHANGE WITH ENGINE SPEED. AT IDLE THE LIGHTS WILL DIM. AS THE ENGINE IS SPEEDED UP, THE LIGHTS WILL BECOME THEIR BRIGHTEST.

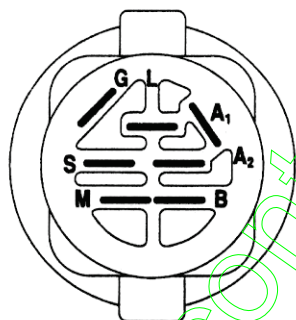

IGNITION SWITCH

POSITION	CIRCUIT	"MAKE"
OFF	M+G+A1	NONE
RUN/LIGHT	B+A1	A2+L
RUN	B+A1	NONE
START	B + S + A1	NONE

WIRING INSULATED CLIPS

NOTE: IF WIRING INSULATED CLIPS WERE REMOVED FOR SERVICING OF UNIT, THEY SHOULD BE REPLACED TO PROPERLY SECURE YOUR WIRING.

NON-REMOVABLE CONNECTIONS

REMOVABLE CONNECTIONS

REPAIR PARTS

TRACTOR- -MODEL NO. 917. 277020

ELECTRICAL

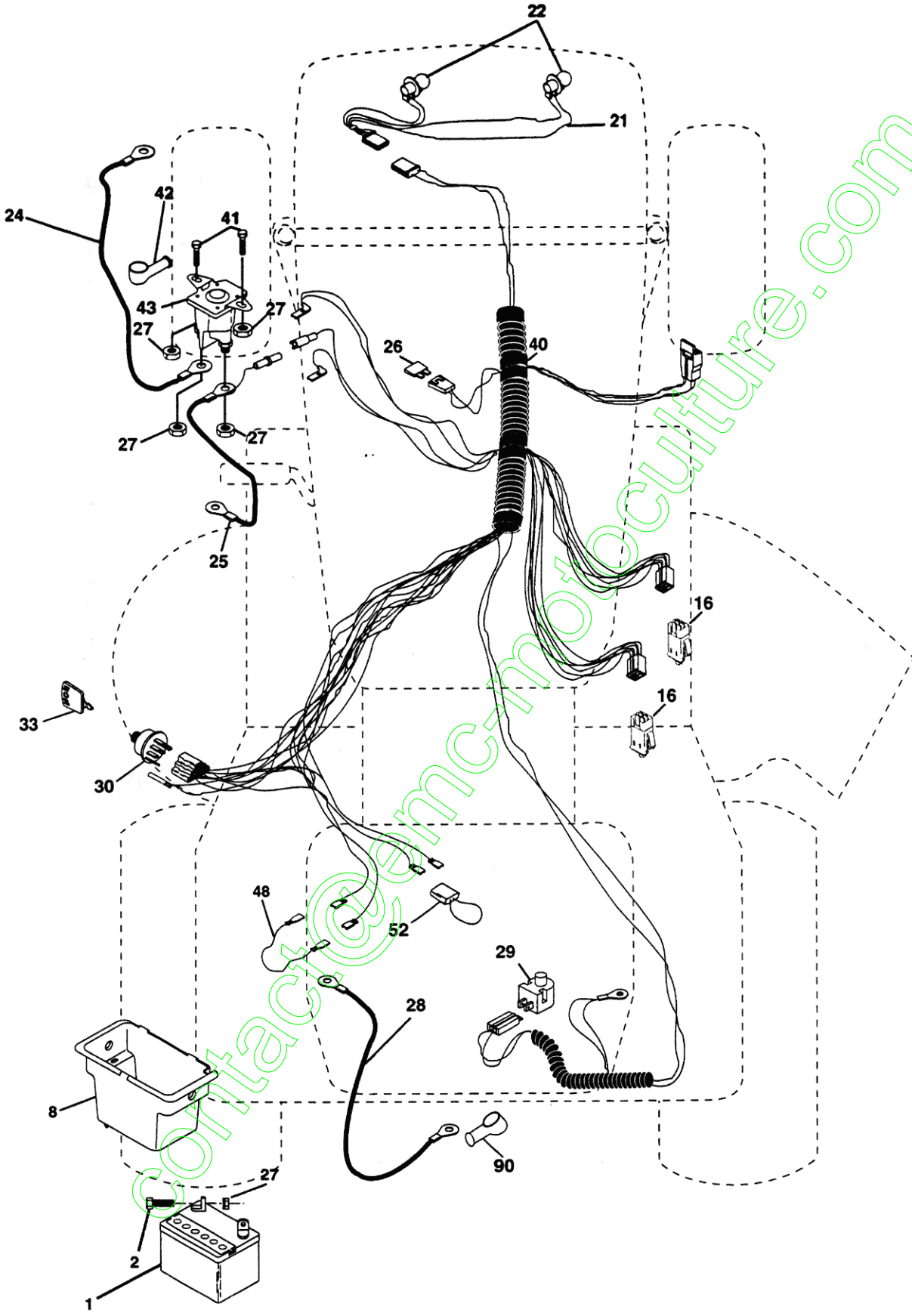

REPAIR PARTS

TRACTOR- -MODEL NO. 917. 277020

ELECTRICAL

KEY NO.	PART NO.	DESCRIPTION
1	163465	Battery 12 VOLT 28 AMP
2	74760412	Bolt Hex Hd 1/4-20unc x 3/4
8	176689	Battery Box
16	176138	Switch, Interlock Push-In
21	175685	Harness Asm Light W/4152j
22	4152J	Bulb Light #1156
24	4799J	Cable Battery 6 Ga 11" red
25	146147	Cable Battery 6 Ga w/16 wire red
26	175158	Fuse 20 AMP
27	73510400	Nut, Keps Hex 1/4-20 UNC
28	4207J	Cable Ground 6 Ga 12" black
29	121305X	Switch Plunger Nc Gray
30	175566	Switch Ign
33	140403	Key Ign Molded Craftsman
40	179720	Harness Ign
41	71110408	Bolt Blk. Fin Hex 1/4-20 Unc x 1/2
42	131563	Cover Terminal Red
43	178861	Solenoid
48	140844	Adapter Ammeter
52	141940	Protection Wire Loop
90	180449	Cover Terminal

NOTE: All component dimensions give in U.S. inches
1 inch = 25.4 mm

REPAIR PARTS

TRACTOR- -MODEL NO. 917. 277020

CHASSIS AND ENCLOSURES

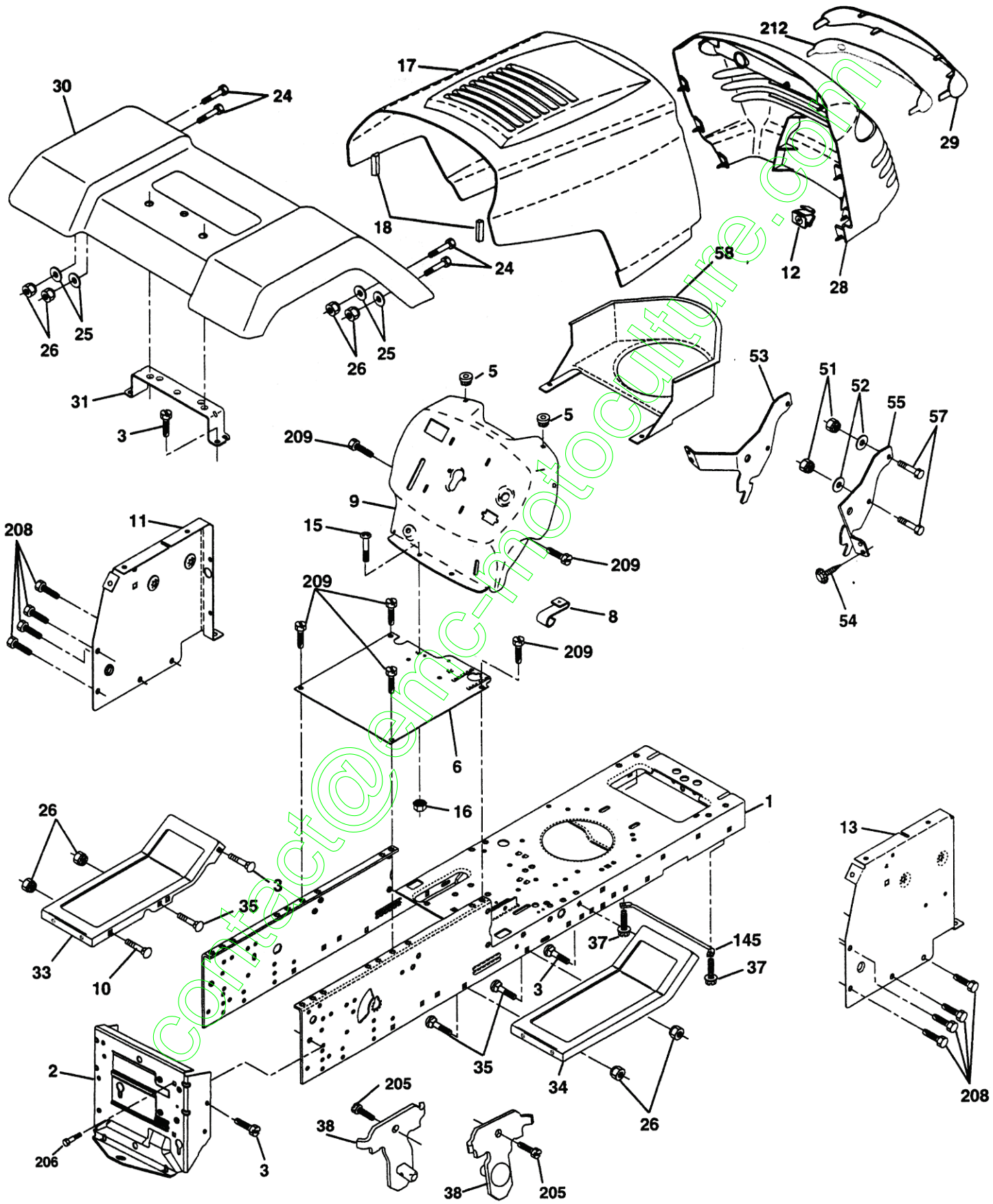

REPAIR PARTS

TRACTOR- -MODEL NO. 917. 277020

CHASSIS AND ENCLOSURES

KEY NO.	PART NO.	DESCRIPTION
1	174620	Chassis
2	176554	Drawbar
3	17060612	Screw 3/8-16 x 3/4
5	155272	Bumper Hood/Dash
6	174643X014	Saddle
8	126471X	Clip
9	168347X011	Dash
10	STD533710	Bolt, Carriage 3/8-16 x 3/4
11	174996	Panel, Dash, L.H.
12	145660	Clip Tinnerman Grille P/L
13	172105X010	Panel, Asm. SLKSCR Dash R.H.
15	74180512	Screw Mach Thrd 5/16-18 UNC 3/4
16	73510500	Nut Keps 5/16-18 UNC
17	159639X558	Hood Assembly
18	126938X	Bumper Hood
24	74780616	Bolt Fin Hex 3/8-16 UNC x 1 Gr. 5
25	19131312	Washer 13/32 x 13/16 x 12 Gauge
26	STD541437	Nut, Lock Hex W/Ins. 3/8-16 UNC
28	179777	Grille w/Lens Asm.
29	150209X599	Lens, Grille
30	169465X558	Fender
31	136619	Bracket, Fender Support
33	179716X558	Footrest LH
34	179717X558	Footrest RH
35	72140608	Bolt RDHD Sqnk 3/8-16 UNC x 1
37	17490508	Screw Thdrol 5/16-18 x 1/2 TYT
38	175710	Bracket Asm Pivot
51	73800400	Nut Lock w/Insert 1/4-20 UNC
52	19091416	Washer 9/32 x 7/8 x 16 Ga.
53	144697	Bracket Grille LH
54	161464	Screw Hex WSHD 8-18 x 7/8
55	144696	Bracket Grille RH
57	STD522507	Bolt, Fin Hex 1/4-20 UNC x .75
58	150127	Duct Air Engine
145	156524	Rod Pivot Chassis/Hood
205	17490608	Screw Hexwsh Thdrol 3/8-16 x 1/2
206	170165	Bolt Shoulder 5/16-18 TT
208	17670608	Screw Thdrol 3/8-16 x 1/2
209	17000612	Screw Hexwsh Thdrl 3/8-16 x 3/4
212	156494	Insert Lens Reflective
--	5479J	Plug, Button

NOTE: All component dimensions give in U.S. inches
1 inch = 25.4 mm

REPAIR PARTS

TRACTOR- -MODEL NO. 917. 277020

DRIVE

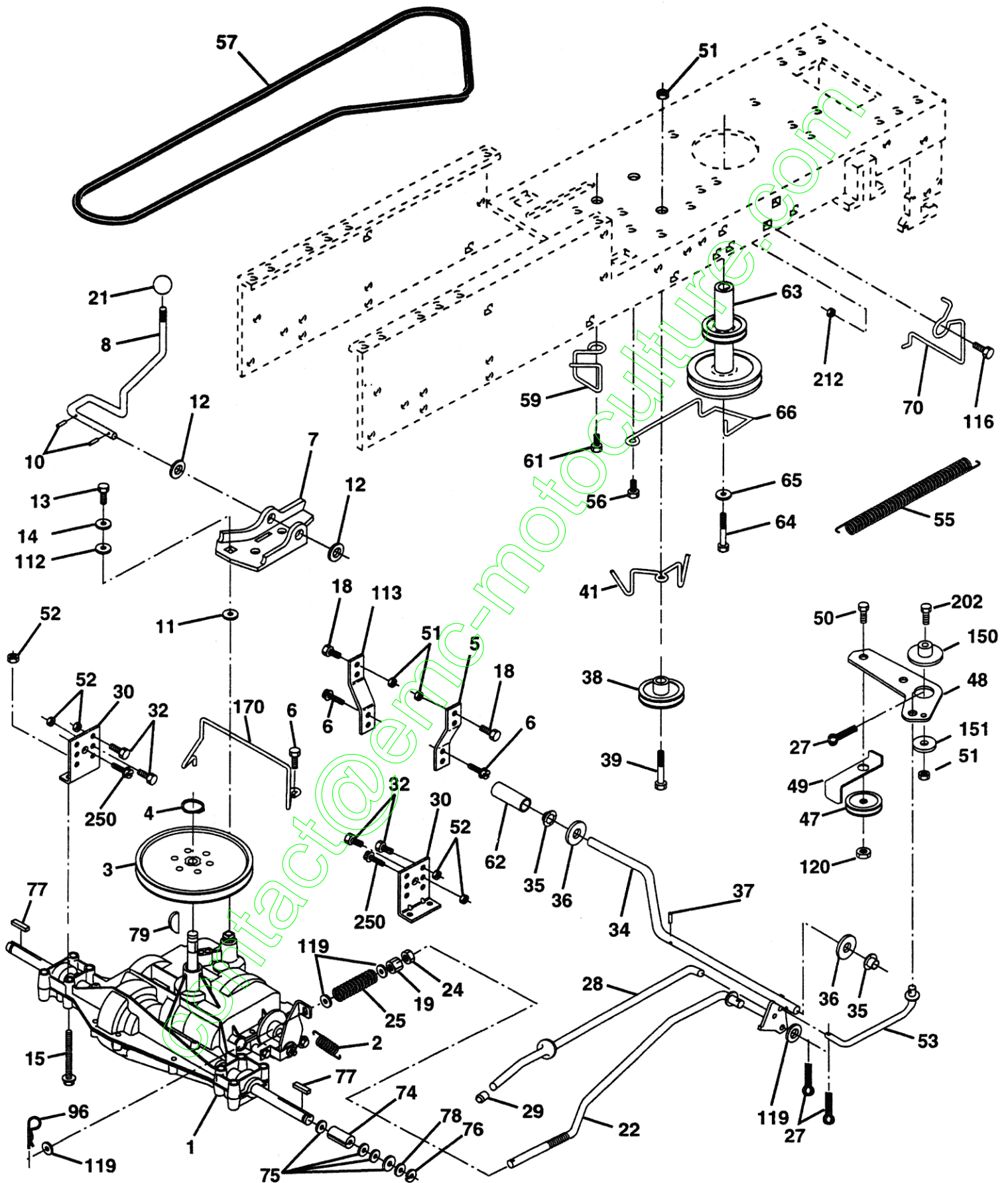

REPAIR PARTS

TRACTOR- -MODEL NO. 917. 277020

DRIVE

KEY NO.	PART NO.	DESCRIPTION	KEY NO.	PART NO.	DESCRIPTION
1	-----	Transaxle Dana D4360-139 (Order parts from transaxle Manufacturer)	49	123205X	Retainer Belt Style Spring
2	146682	Spring Return Brake T/a Zinc	50	74760624	Bolt Hex Hd 3/8-16unc x1-1/2
3	123666X	Pulley Transaxle 18/20" tires	51	73680600	Nut Crownlock 3/8-16 UNC
4	12000028	Ring Retainer # 5100-62	52	73680500	Nut Crown Lock 5/16-18
5	121520X	Strap Torque 30 Degrees	53	105710X	Link Clutch 7 66
6	17000512	Screw 5/16-18 x 3/4	55	105709X	Spring Return Clutch 6 75
7	162240	Bracket Saddle Shift T/a	56	17060620	Screw 3/8-16 x 1-1/4
8	131679	Rod Shf Sdl LY/YT Str Blk	57	160855	V-Belt Gd Drive 9530
10	76020416	Pin Cotter 1/8 x 1 Cad	59	169691	Keeper Belt Centerspan
11	105701X	Washer Plate 388 Sq Hole	61	17120614	Screw 3/8-16 x .875
12	19151216	Washer 15/32 x 3/4 x 16ga	62	8883R	Cover Pedal Blk Round
13	74550412	Bolt 1/4-28unf Gr8 W/Patch	63	180219	Pulley Eng
14	10040400	Washer Lock Hvy Helical 1/4	64	71170764	Bolt Hex 7/16-20 x 4 Gr 5
15	74490544	Bolt Hex Flghd 5/16-18 x Gr. 5	65	10040700	Washer Lock Hlcl Spr 7/16
18	74780616	Bolt Fin Hex 3/8-16 UNC x 1 Gr. 5	66	154778	Keeper Belt Engine FP
19	73800600	Nut Lock Hex W/Ins. 3/8-16 Unc	70	180218	Guide Belt Mower Drive RH
21	106933X	Knob Rd 1/2-13 Plstc Thds	74	109502X	Spacer Axle
22	130804	Rod Brake Blk Zinc 26 840	75	121749X	Washer 25/32 x 1-1/4 x16 Ga
24	73350600	Nut Hex Jam 3/8-16 Unc	76	12000001	E-ring #5133-75
25	106888X	Spring Rod Brake 2 00 Zinc	77	123583X	Key Square 2 0 x 1845/ 1865
27	76020412	Pin Cotter 1/8 x 3/4 Cad	78	121748X	Washer 25/32 x1-5/8 x 16 Ga
28	175765	Rod Brake Parking Lt/Yt	79	2228M	Key Woodruff
29	71673	Cap Brake Parking	96	4497H	Retainer Spring 1"
30	174973	Bracket Mtg Transaxle	112	19091210	Washer 9/32 x 3/4 x 10 Ga
32	74760512	Bolt Hex Hd 5/16-18unc x 3/4	113	127285X	Strap Torque LH LT
34	175578	Shaft Asm Pedal Foot	116	72140608	Bolt RDHD Sqnk 3/8-16 UNC x 1
35	120183X	Bearing Nylon Blk 629 Id	119	19131016	Washer 13/32 x 5/8 x 16 Ga.
36	19211616	Washer 21/32 x 1 x 16 Ga	120	73900600	Nut Lock Flg. 3/8-16 UNC
37	1572H	Pin Roll 3/16 x 1"	150	175456	Retainer Spacer
38	179114	Pulley Composite Flat	151	19133210	Washer 13/32 x 2 x 10 Ga.
39	74760648	Bolt Fin Hex 3/8-16 UNC x 2-3/4 Gr. 5	170	178394	Keeper Belt Transaxle Gear
41	175556	Keeper Belt Idler	202	72110614	Bolt Carr. Sh 3/8-16 x 1-3/4 Gr. 5
47	127783	Pulley Idler V Groove Plastic	212	145212	Nut Hex Flange Lock
48	154407	Bellcrank Asm. Clutch	250	17060612	Screw 3/8-16 x .75

NOTE: All component dimensions given in U. S. inches 1 inch = 25.4 mm

REPAIR PARTS

TRACTOR- -MODEL NO. 917. 277020

STEERING ASSEMBLY

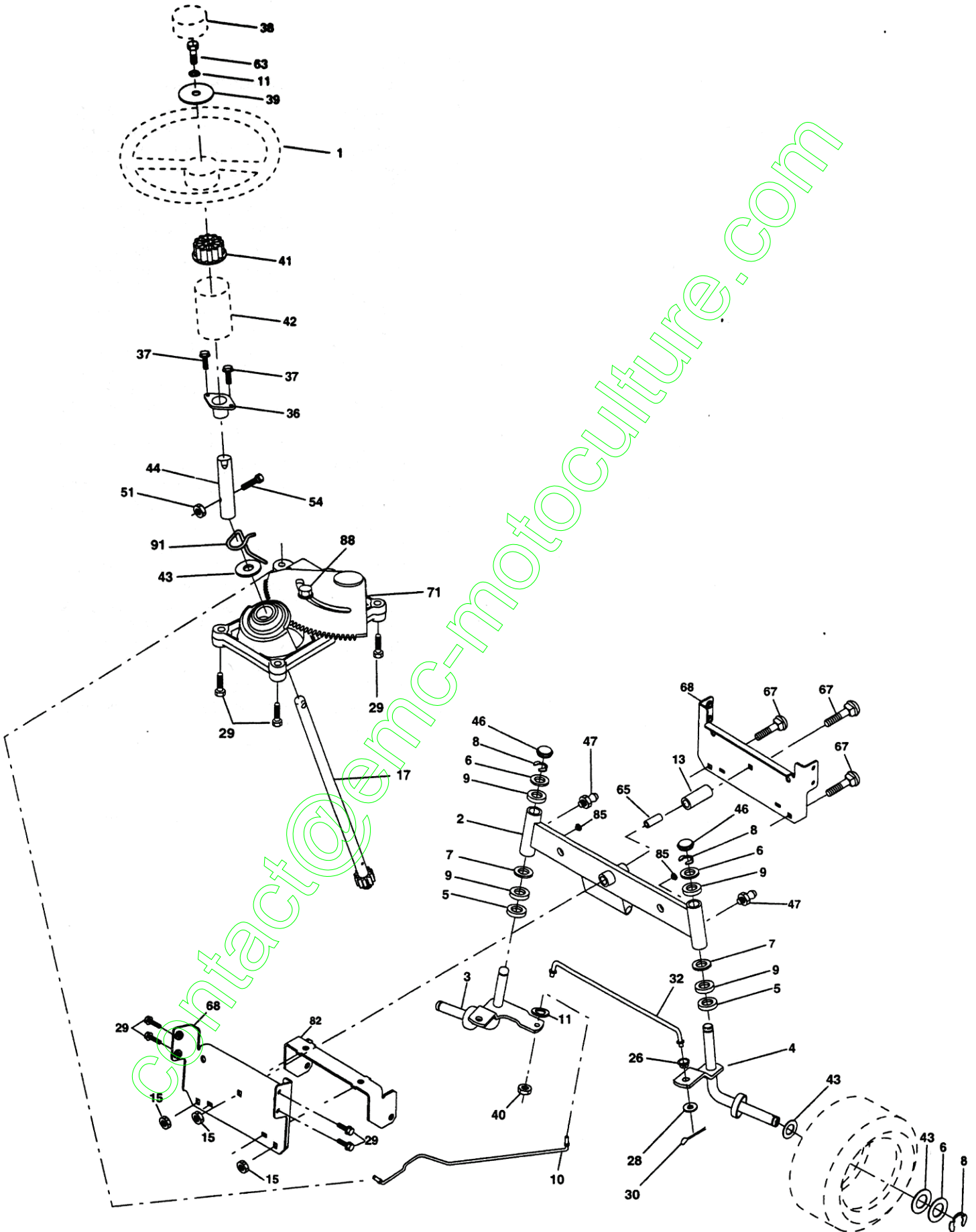

REPAIR PARTS

TRACTOR- -MODEL NO. 917. 277020

STEERING ASSEMBLY

KEY NO.	PART NO.	DESCRIPTION
1	140044X428	Steering Wheel
2	175131	Front Axle Assembly
3	169840	Spindle Assembly, L.H.
4	169839	Spindle Assembly, R.H.
5	6266H	Bearing, Race, Thrust, Hardened
6	121748X	Washer 25/32 x 1-5/8 x 16 Gauge
7	19272016	Washer 27/32 x 1-1/4 x 16 Gauge
8	12000029	Ring, Klip
9	3366R	Bearing, Steering Column
10	175121	Link, Drag
11	STD551137	Washer, Lock
13	136518	Spacer, Bearing, Front Axle
15	145212	Nut Lock Hex Flange
17	177876	Shaft Assembly, Steering
26	126847X	Bushing, Link, Drag
28	19131416	Washer 13/32 x 7/8 x 16 Gauge
29	17060612	Screw 3/8-16 x 3/4
30	STD561210	Pin
32	130465	Rod, Tie
36	155099	Bushing, Steering
37	152927	Screw TT #10-32 x 5 x 3/8 Flange
38	140045X428	Cap Wheel Steer Blk
39	19133812	Washer 13/32 x 2-3/8 x 12 Gauge
40	STD541537	Nut Lock Center 3/8-24 UNF
41	100711L	Adaptor, Steering Wheel
42	145054X428	Boot, Steering Dash P/L Mtl Blk
43	121749X	Washer 25/32 x 1-1/4 x 16 Gauge
44	153720	Extension Steering Non-Adjust
46	121232X	Cap, Spindle
47	6855M	Fitting, Grease
51	STD541431	Nut Lock Hx W/Ins 5/16-18 UNC
54	74780520	Bolt Fin Hex 5/16-18 UNC x 1-1/4
63	STD523710	Bolt Fin Hex 3/8-16 unc. x 1 Gr. 5
65	160367	Spacer Brace Axle
67	72140618	Bolt Rdhd Sq 3/8-16 x 2-1/4
68	169827	Brace Axle
71	175146	Steering Asm.
82	169835	Bracket Susp Chassis Front
85	133835	Fastener Christmas Tree
88	175118	Bolt Shoulder 7/16-20
91	175553	Clip Steering

NOTE: All component dimensions given in U.S. inches 1 inch = 25.4 mm

REPAIR PARTS

TRACTOR- -MODEL NO. 917. 277020

SEAT ASSEMBLY

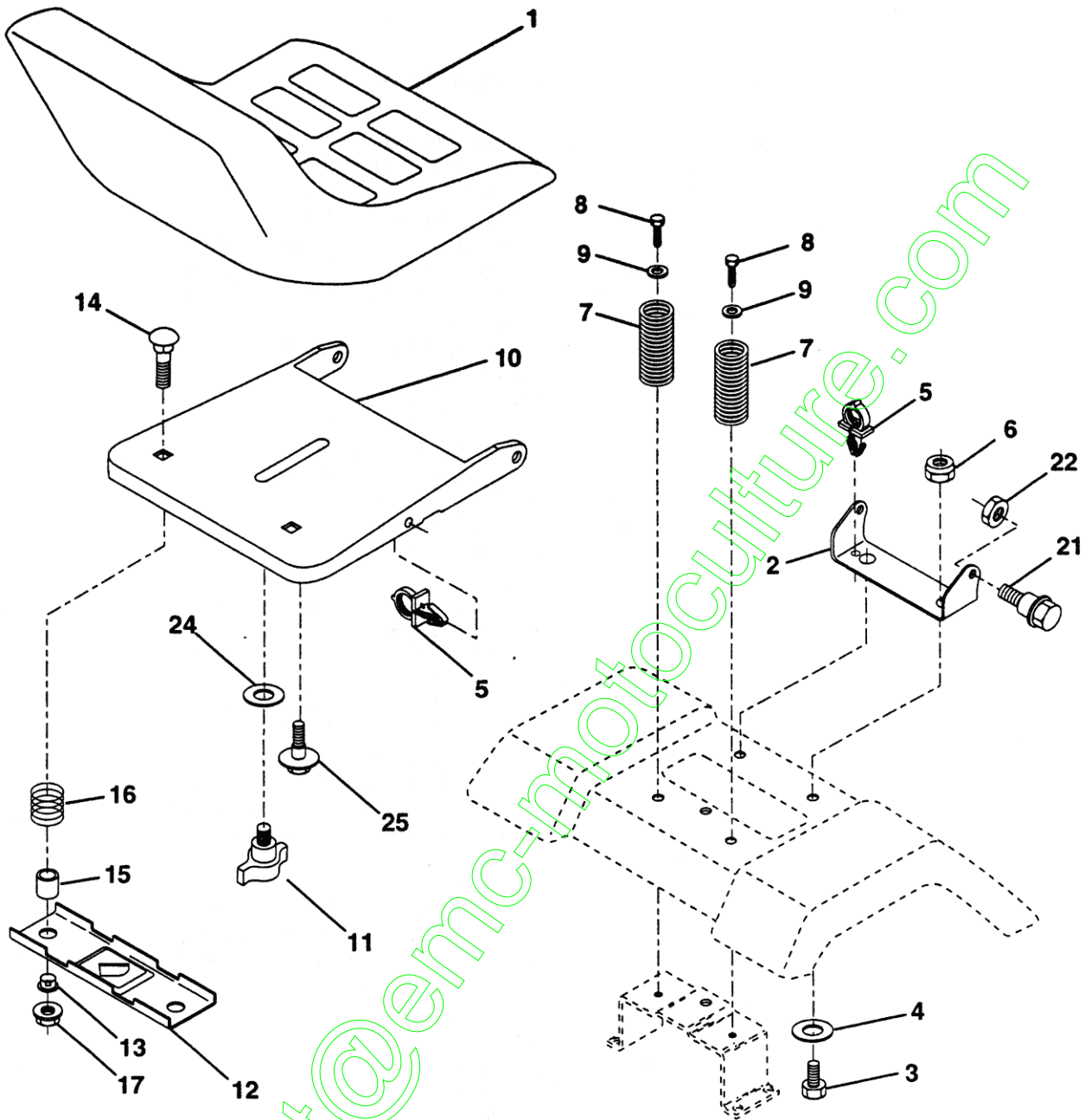

KEY NO.	PART NO.	DESCRIPTION
1	127427	Seat
2	140551	Bracket Pnt Pivot Seat (blk)
3	71110616	Bolt Fin Hex 3/8-16unc X 1
4	19131610	Washer 13/32 X 3/4 X 10 Ga
5	145006	Clip Push In Hinged
6	STD541437	Nut Hex Lock w/Ins 3/8-16 Unc
7	124181X	Spring Seat Cprsn 2 250 Blk Zi
8	17000616	Screw 3/8-16 X 1 -1/2
9	19131614	Washer 13/32 X 1 X 14 Ga
10	174894	Pan Pnt Seat (blk)
11	166369	Knob Seat
12	121246X	Bracket Pnt Mounting Switch

KEY NO.	PART NO.	DESCRIPTION
13	121248X	Bushing Snap Blk Nyl 50 Id
14	72050412	Bolt Rdhd Sht Nk 1/4-20x1-1/2
15	134300	Spacer Split 28 X 96 Zinc
16	121250X	Spring Cprsn 1 27 Blk Pnt
17	123976X	Nut Lock 1/4 Lge Flg Gr 5 Zinc
21	171852	Bolt Shoulder 5/16-18 Unc-2A
22	STD541431	Nut Hex Lock w/Ins 5/16-18
24	19171912	Washer 17/32 X 1-3/16 X 12 Ga
25	127018X	Bolt Shoulder 5/16-18 X 62

NOTE: All component dimensions given in U.S. inches
1 inch = 25.4 mm

REPAIR PARTS

TRACTOR- -MODEL NO. 917. 277020

DECALS

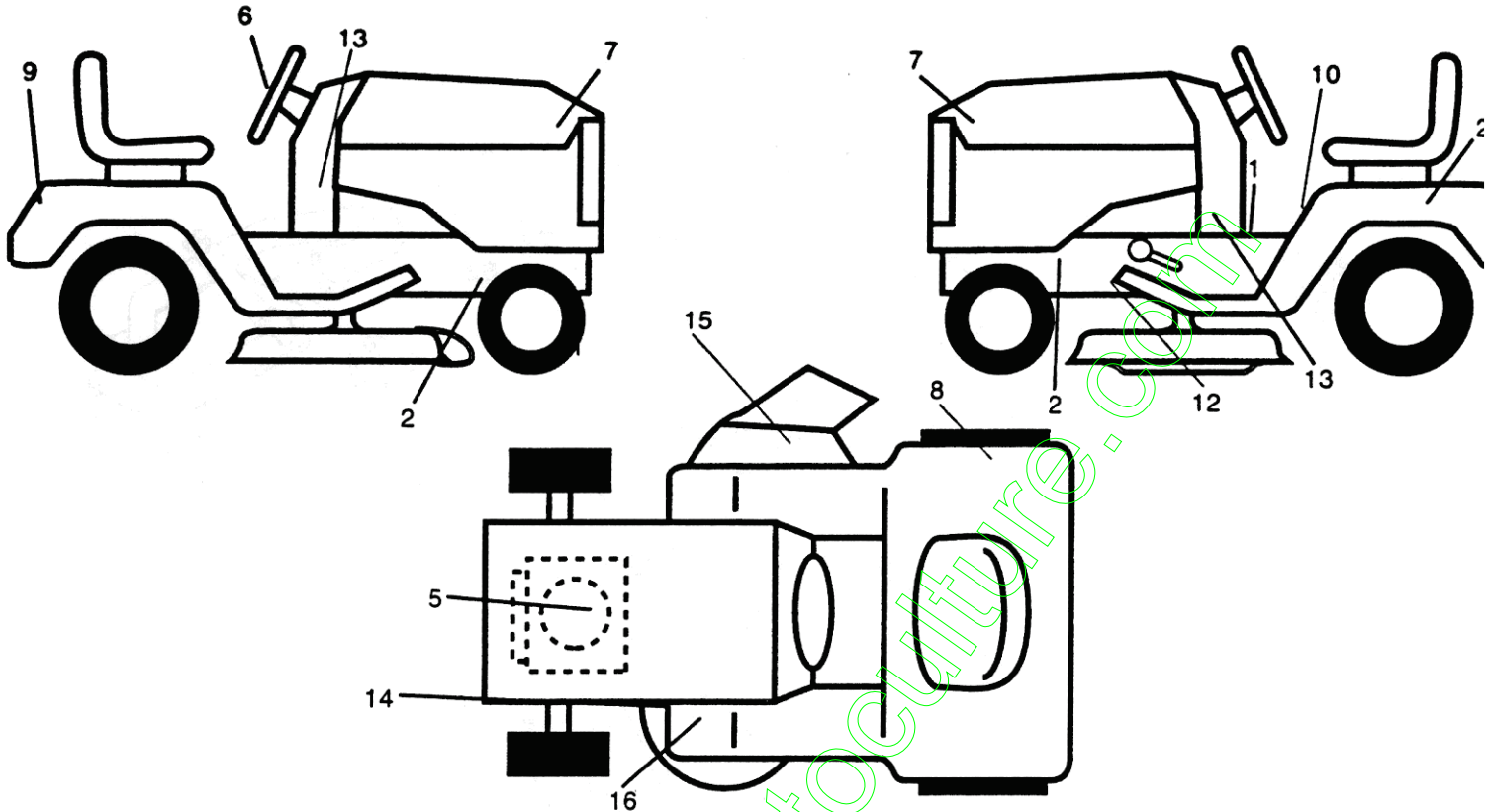

KEY NO.	PART NO.	DESCRIPTION	KEY NO.	PART NO.	DESCRIPTION
1	140837	Decal, Brake Parking Saddle	14	136832	Decal, V-belt Schematic
2	159736	Decal, Chassis Hot Muffler	15	182166	Decal, Cut Finger
5	176675	Decal, Hp Engine	16	159737	Decal, Brake/Clutch
6	172275	Decal, Steering Wh	20	145005	Decal, Battery Dngr/Psn Eng
7	171704	Decal, Hood	--	162598	Decal, Drawbar Load Limit
8	180432	Decal, 100 DB/CE	--	138311	Decal, Lift Handle
9	163204	Decal, Fender Craftsman	--	182547	Manual, Oper (Euro)
10	145498	Decal, Read Owners Manual	--	182548	Manual, Oper (Scan)
12	146046	Decal, V-belt Dr Sch	--	182549	Manual, Parts
13	177097	Decal, Dash, Panel			

WHEELS & TIRES

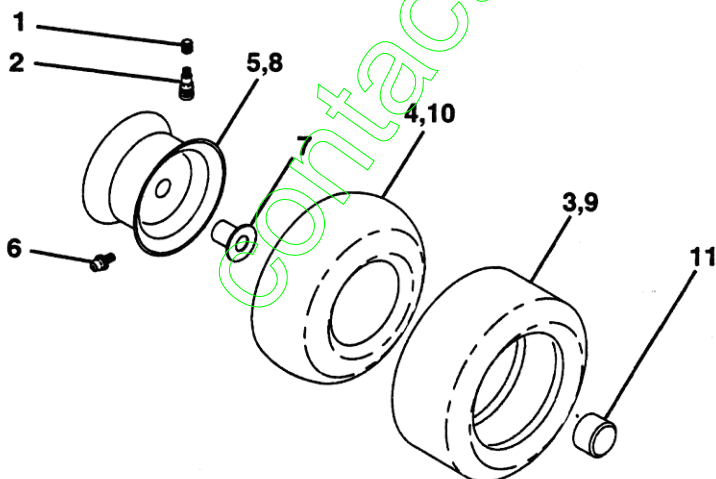

KEY NO.	PART NO.	DESCRIPTION
1	59192	Cap Value Tire
2	65139	Stem Value
3	106222X	Tire F Ts 15 X 6 0 - 6 Service
4	59904	Tube Inner Front #35060
5	106732X427	Rim Asm 6"front White Service
6	278H	Fitting Grease
7	9040H	Bearing Flange
8	106108X427	Rim Asm 8"rear White Service
9	124635X	Tire R Ts 18 X 8 5-8 Service
10	7152J	Tube Rear 9 5 X 8 Service
11	104757X428	Cap Axle Blk 1 50 X 1 00
--	144334	Sealant, Tire (10 oz. tube)

NOTE: All component dimensions given in U.S. inches
1 inch = 25.4 mm

REPAIR PARTS

TRACTOR- -MODEL NO. 917. 277020

ENGINE

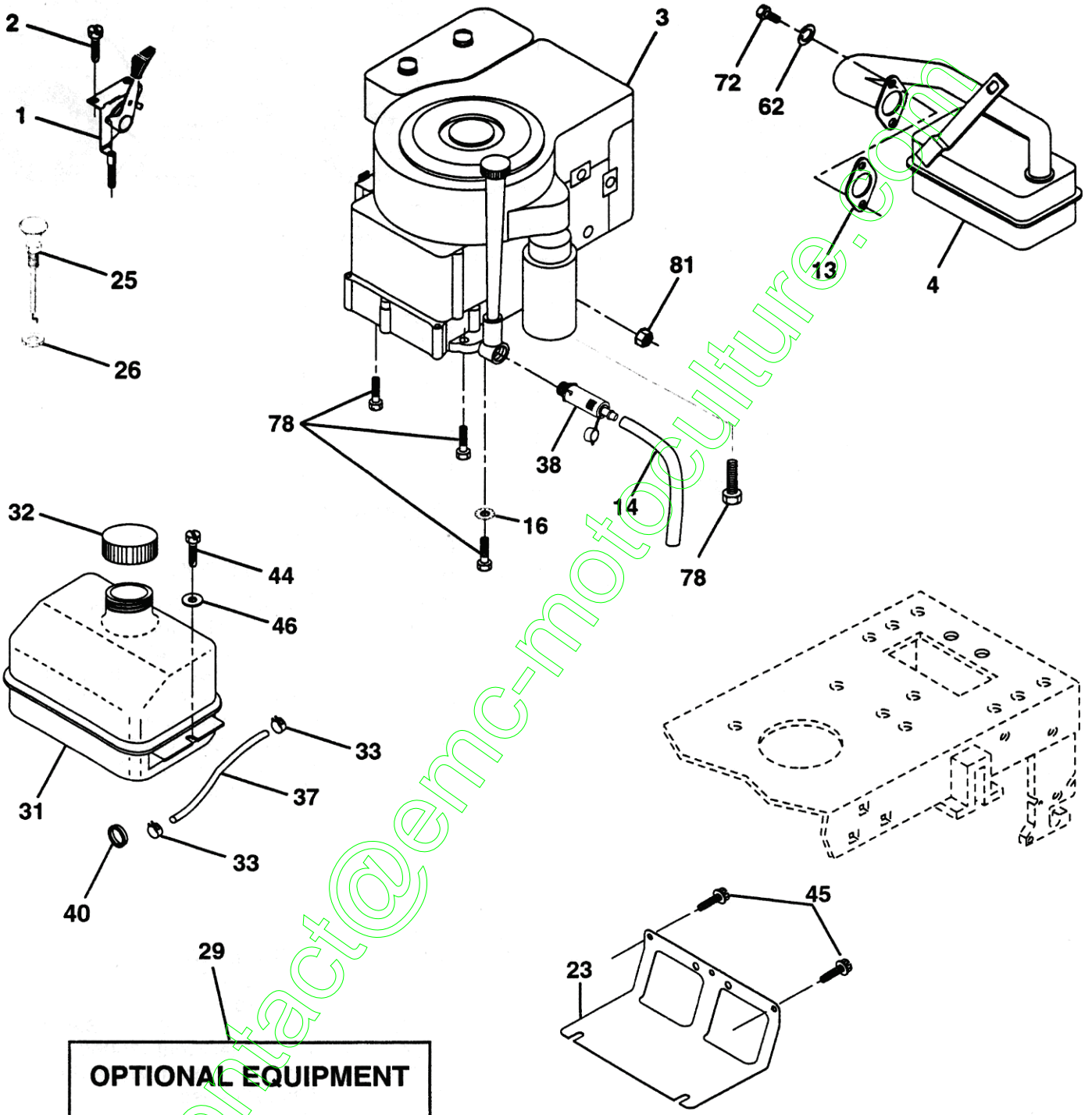

OPTIONAL EQUIPMENT
Spark Arrester

REPAIR PARTS

TRACTOR- -MODEL NO. 917. 277020

ENGINE

KEY NO.	PART NO.	DESCRIPTION
1	170551	Control Throttle
2	17720408	Screw Hex Thd Cut 1/4-20x1/2
3	-----	Engine (See Breakdown) Briggs Model 287707-1286-E1
4	137352	Muffler
13	165291	Gasket 1 313 Id Tin Plated
14	148456	Tube Drain Oil
16	STD551237	Washer Lock Ext Tooth 3/8
23	169837	Shield BRN/DBR Guard
25	180945	Control Choke
26	73920600	Nut Keps 3/8-24 UNF
29	137180	Arrestor Spark
31	109202X	Tank Fuel 1 25 Fr
32	158990	Cap Asm Fuel W/sym Vented
33	123487X	Clamp Hose Blk
37	137040	Line Fuel 20"
38	148315	Plug Oil Drain
40	124028X	Bushing Snap Nyl Blk Fuel Line
44	17670412	Screw Hexwsh Thdrol 1/4-20x3/4
45	17000612	Screw Hexwsh Thdr 3/8-16 x 3/4
46	19091416	Washer 9/32 X 7/8 X 16ga
62	STD551131	Washer Lock Hvy Hlcl Spr 5/16
72	71070512	Screw Hexhd Cap 5/16-18x3/4
78	17060620	Screw 3/8-16x1-1/4
81	73510400	Nut Keps Hex 1/4-20unc

NOTE: All component dimensions given in U.S. inches
1 inch = 25.4 mm

REPAIR PARTS

TRACTOR- -MODEL NO. 917. 277020

MOWER LIFT

KEY NO.	PART NO.	DESCRIPTION
1	159460	Washer Asm Inner Spring W/Plunger
2	159471	Shaft Asm. Lift RH
3	105767X	Pin Groove
4	12000002	E Ring #5133-62
5	19211621	Washer 21/32 x 1 x 21 Ga.
6	120183X	Bearing Nylon
7	125631X	Grip Handle Fluted
8	122365X	Button Plunger Read
11	139865	Link Asm Lift L.H.
12	139866	Link Asm Lift R.H.
13	STD624008	Retainer Spring
15	173288	Link Front
16	73350800	Nut Jam Hex 1/2-13 Unc
17	175689	Trunnion Blk Zinc
18	73800800	Nut Lockw/wsh 1/2-13 Unc
19	139868	Arm Suspension Mower
20	163552	Retainer Spring
31	169865	Bearing, Pvt. Lift.
32	73540600	Nut Crownlock 3/8-24

NOTE: All component dimensions given in U.S. inches
1 inch = 25.4 mm

REPAIR PARTS

TRACTOR- -MODEL NO. 917. 277020

MOWER

KEY NO.	PART NO.	DESCRIPTION	KEY NO.	PART NO.	DESCRIPTION
1	170280	Mower Housing Assembly	69	76020312	Pin, Cotter 3/32 x 3/4
2	72140506	Bolt, Carriage 5/16-18 x 3/4	86	7631J	Runner, LH
3	138017	Bracket Asm. Fram Sway Bar	87	128772	Runner, RH
4	169970	Bracket, Asm. Deck Sway Bar	88	19111216	Washer 11/32 x 3/4 x 16 Ga
5	4939M	Retainer, Spring	89	19131612	Washer 13/32 x 1 x 12 Ga
6	178024	Bar Sway Deck	96	74930620	Bolt 3/8-16 x 1-1/4
8	850857	Bolt, Hex 3/8-24 x 1-1/4 Gr 8	97	73930600	Nut Centerlock 3/8-16 Unc
9	10030600	Washer, Lock, Hlcl Sprg 3/8	98	19132016	Washer 13/32 x 1-1/4 x 16 Ga.
10	140296	Washer, Hard Blade Mower Vented	99	10040600	Washer Lock 3/8
11	134148	Blade, Mower, Mulching 38"	100	135651	Nut Wing
13	137645	Shaft and Bearing Assembly (Includes Key Number 15)	101	132803	Cover Asm. Mulching
14	128774	Mandrel Housing, Vented	107	133502	Spacer, Retainer
15	110485X	Ball Bearing, Mandrel	108	133503	Stiffener, Idler Arm
16	174493	Stripper, Mower, Vented	109	74760640	Bolt, Hex Head 3/8-16 x2-1/2
19	132827	Bolt, Shoulder	110	142587	Upstop Deck Front 38"
21	73680500	Nut, Crownlock 5/16-18	113	17060512	Screw 5/16-18 x 3/4
23	137607	Bracket, Mower Deflector	122	131289	Rod, Brake, LH
24	105304X	Cap, Sleeve	123	169971	Rod, Brake, RH
25	123713X	Spring, Deflector	146	165891	Bolt Carriage Idler
26	110452X	Nut, Push	148	169022	Spring Return Idler
27	106736X428	Shield, Deflector	149	165898	Retainer Spring Yellow Zinc
28	19111016	Washer 11/32 x 3/4 x 16 Ga	150	19091216	Washer 9/32 x 3/4 x 16 Ga.
29	106735X	Rod, Hinge	151	169670	Bracket Clutch
30	173984	Screw, Thdro Washer Hd	152	172758	Cable Clutch 38 In
31	129963	Washer, Spacer	153	169674	Washer Flat 3/8" Type B
32	153532	Pulley, Mandrel	154	169675	Spring Retainer
33	178342	Nut, Flangelock 9/16	155	169671	Spring Retention Lever
36	131494	Pulley, Idler, Flat	156	169672	Spacer
40	73680600	Nut Crownlock 3/8-16 UNC	157	169669	Rod Clutch
45	4497H	Retainer, Spring	158	17720408	Screw Hex Thd Cut 1/4-20x1/2
53	130840	Brake Assembly	--	130794	Mandrel Assembly (Includes Housing, Shaft and Shaft Hardware Only - Pulley Not Included)
54	133943	Washer Hardened	--	181209	Mower Replacement, Complete
55	133840	Idler Arm Assembly			
56	165723	Spacer, Retainer			
67	149846	Knob			
68	180214	Belt			

NOTE: All component dimensions given in U.S. inches
1 inch = 25.4 mm

REPAIR PARTS

TRACTOR- -MODEL NO. 917. 277020

DANA TRANSAXLE - MODEL NUMBER 4360-139

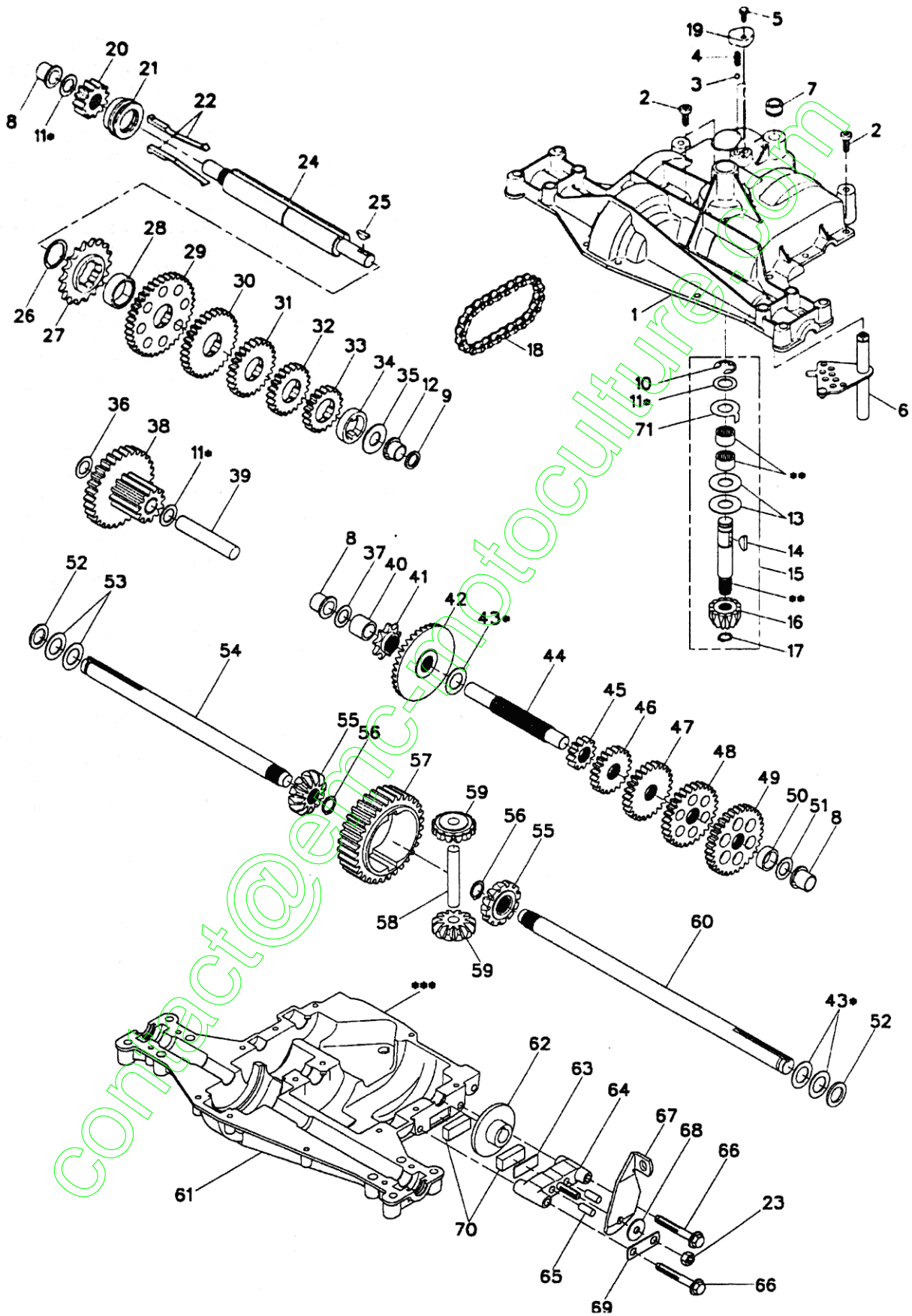

REPAIR PARTS

TRACTOR- -MODEL NO. 917. 277020

DANA TRANSAXLE - MODEL NUMBER 4360-139

KEY NO.	PART NO.	DESCRIPTION	KEY NO.	PART NO.	DESCRIPTION
1	170981	Housing, Upper	41	105928X	Sprocket, 9T
2	2274J	Screw, Tapping, 1/4-20 X .734	42	170988	Gear, Bevel, 36T
3	134400	Ball, Detent	43	134394	*Assy, Kit, Shim, .750 Shaft
4	105904X	Spring, Detent	44	120473X	Shaft, Drive
5	160940	Screw, Tapping, No. 10-24 X .482	45	142678	Gear, Spur, 12T
6	138235	Assy, Kit, Shifter	46	124641 X	Gear, Spur, 20T
7	108727X	V-Ring	47	106589X	Gear, Spur, 25T
8	148266	Bearing, Flange	48	120408X	Gear, Spur, 28T
9	148269	Seal, Oil	49	105937X	Gear, Spur, 31T
10	2225J	Ring, Retaining	50	105936X	Spacer, .781 X 1.00 X .375
11	134793	*Assy, Kit, Shim, .625 Shaft	51	2226J	Washer, Plain, .632 X 1.00 X .060
12	148268	Bearing, Flange	52	134401	Washer, Neoprene
13	120415X	Washer, Plain, .632 X 1.38 X .046	53	2264J	Washer, Plain, .758 X 1.25 X .031
14	142674	Key, Woodruff, No. 9	54	160946	Axle, LH
15	170983	Assy, Kit, Input Shaft	55	170990	Gear, Miter, T, Splined
16	170986	Pinion, Bevel, 12T	56	160948	Ring, Retaining
17	105909X	Ring, Retaining	57	110071X	Gear, Spur, 32T
18	105910X	Chain, 24 Pitches	58	120952X	Shaft, Cross
19	160942	Cover, Detent	59	170991	Gear, Miter, 1 2T, Idler
20	160943	Gear, Spur, 1 2T	60	160950	Axle, RH
21	148267	Collar, Clutch	61	170992	Housing, Lower
22	138236	Assy, Kit, Clutch Keys	62	7294J	Disc, Brake
23	73810500	Nut, Lock, 5/16-24	63	108989X	Spacer, Brake Puck
24	142676	Shaft, Intermediate	64	160952	Jaw, Brake
25	2244J	Key, Woodruff, No. 61	65	120954X	Pin, Dowel
26	105916X	Ring, Retaining	66	160953	Screw, Tapping, 5/16-18 X 2.35
27	120470X	Sprocket, 1 8T	67	138244	Lever, Actuating
28	110070X	Spacer, 1. 131 X 1.45 X .494	68	108996X	Washer, Plain, .321 X 1.00 X .055
29	142677	Gear, Spur, 37T	69	160954	Bracket, Anti-Rotation
30	124644X	Gear, Spur, 30T	70	120951X	Puck, Friction
31	108980X	Gear, Spur, 25T	71	174256	Washer, Anti Rotation
32	120406X	Gear, Spur, 22T	72	120416X	Grease
33	134796	Gear, Spur, 1 9T			
34	134797	Spacer, 1. 133 X 1.50 X .375			
35	105925X	Washer, Plain, .640 X 1.37 X .061			
36	2228J	Washer, Plain, .632 X 1.00 X .046			
37	170987	Washer, Plain, .632 X 1.00 X .031			
38	174255	Assy, Gear, Comb., 12T & 30T			
39	124639X	Shaft, Idler			
40	120472X	Spacer, .633 X .87 X .755			

NOTE: All component dimensions given in U.S. inches
1 inch = 25.4 mm

- * Use in various combinations to maintain proper clearances.
- ** Order Key No. 15.
- *** Silicone Sealant to be applied between Upper and Lower Housings (use Loctite Ultra Gray Silicone 5699 or equivalent).

REPAIR PARTS

TRACTOR- -MODEL NO. 917. 277020

BRIGGS & STRATTON ENGINE - - MODEL NUMBER 287707, TYPE NUMBER 1286-E1

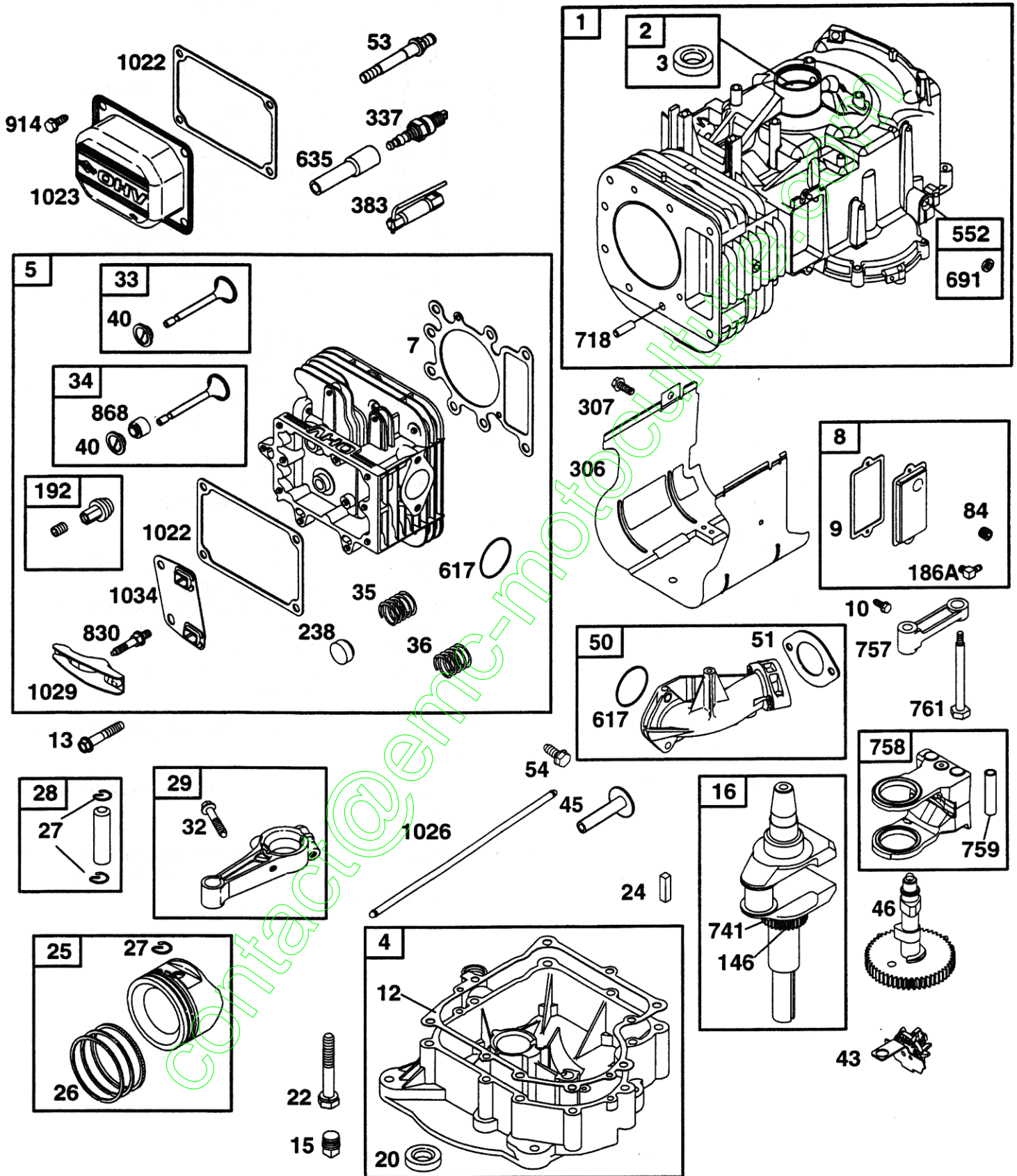

287707-1286-E1

REPAIR PARTS

TRACTOR- -MODEL NO. 917. 277020

BRIGGS & STRATTON ENGINE - - MODEL NUMBER 287707, TYPE NUMBER 1286-E1

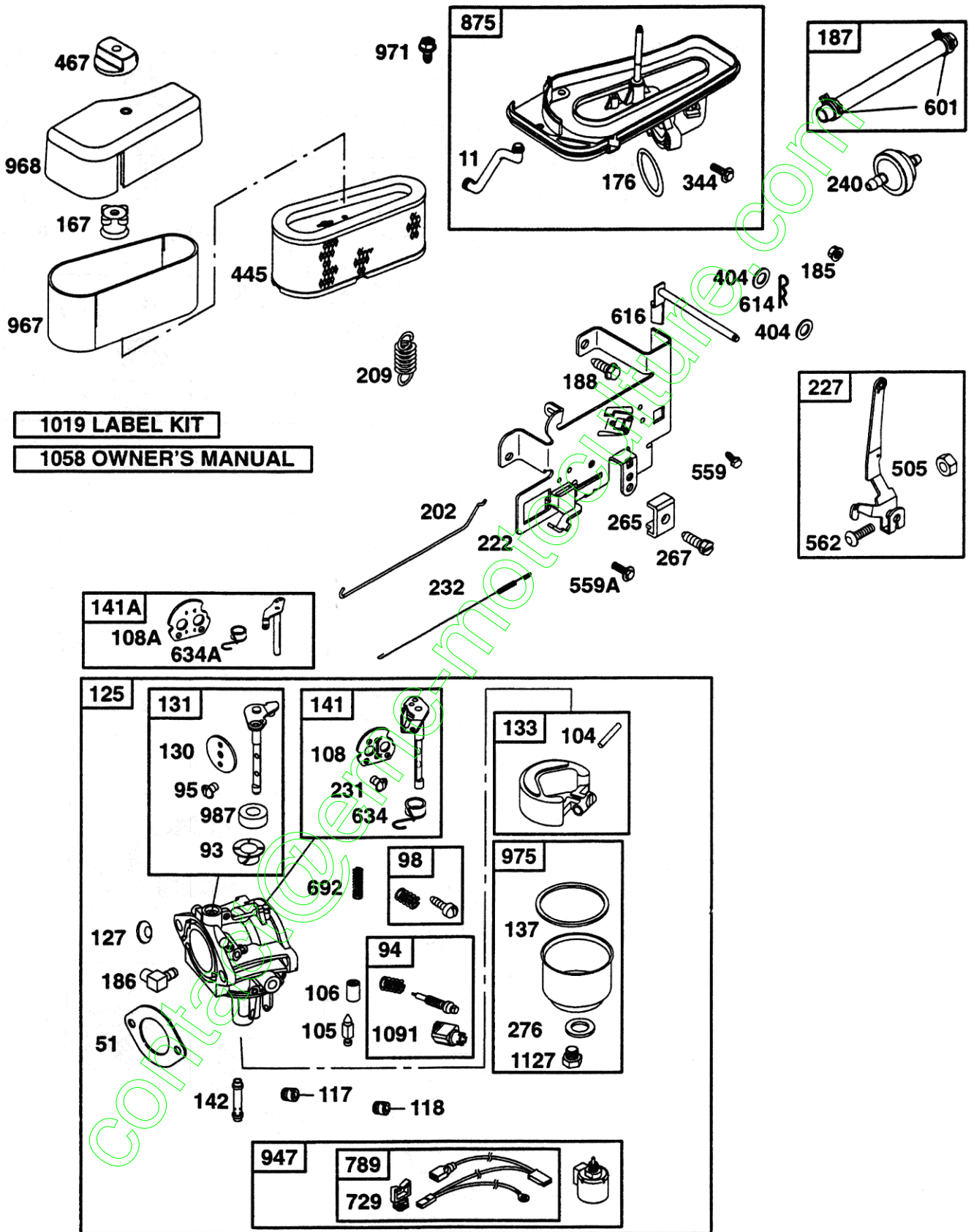

287707-1286-E1

REPAIR PARTS

TRACTOR- -MODEL NO. 917. 277020

BRIGGS & STRATTON ENGINE - - MODEL NUMBER 287707, TYPE NUMBER 1286-E1

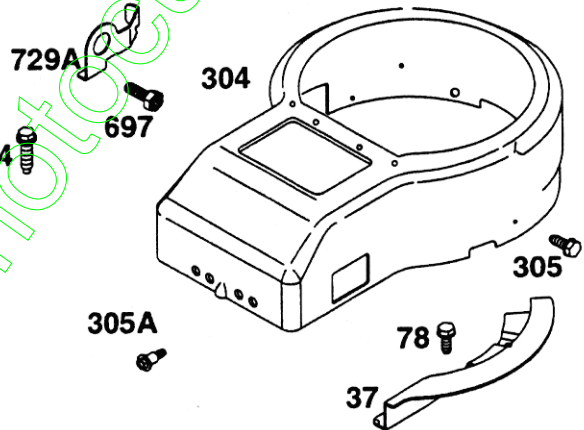
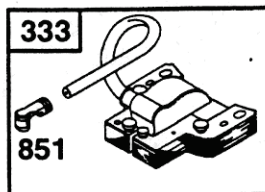
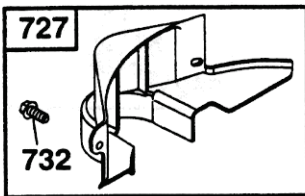
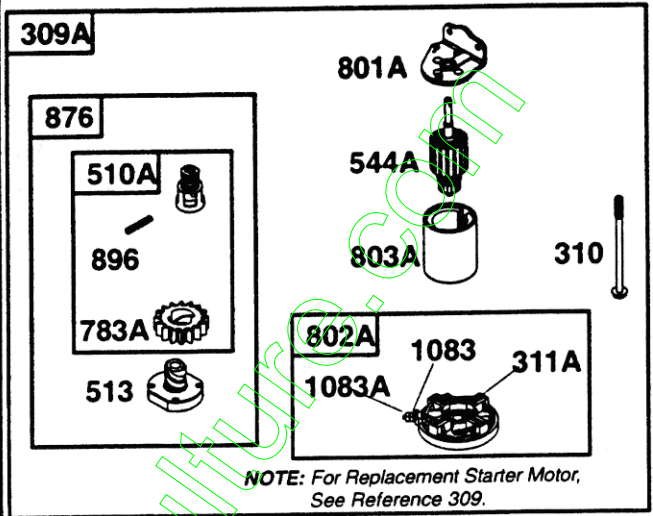
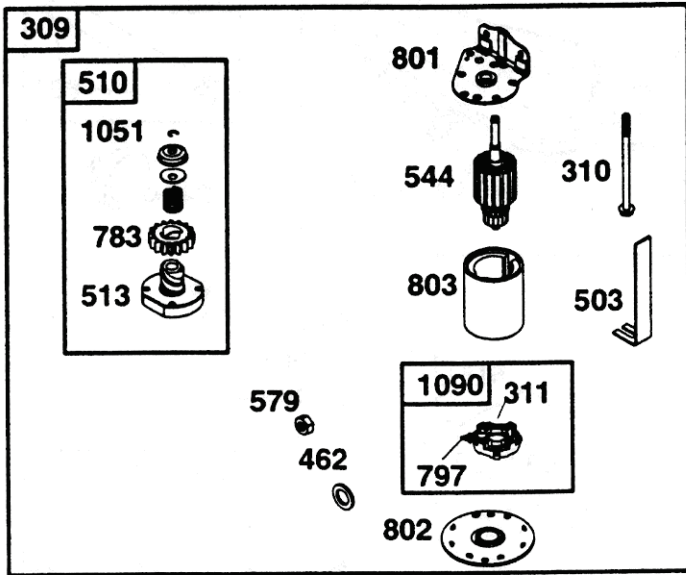

1036 LABEL-EMISSION

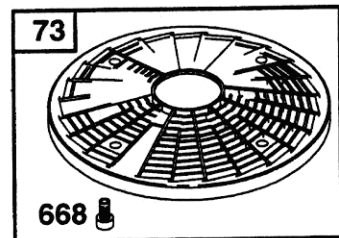
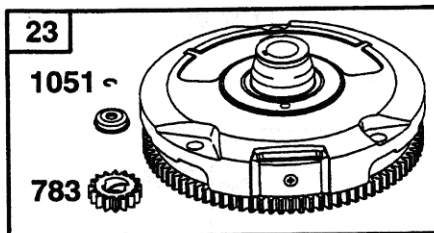
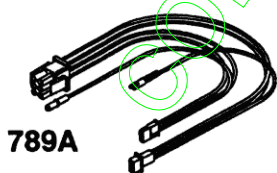
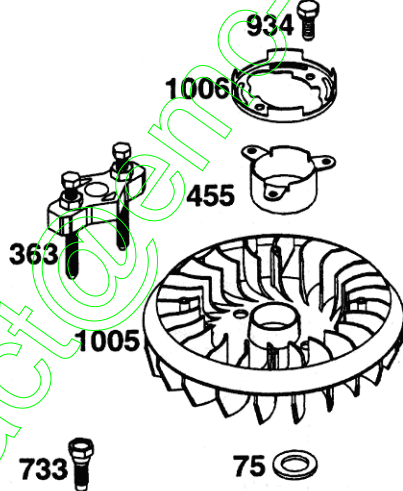
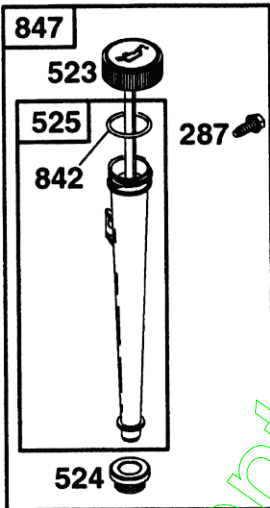

287707-1286-E1

PARTS

TRACTOR- -MODEL NO. 917. 277020
 & STRATTON ENGINE - - MODEL NUMBER 287707, TYPE NUMBER 1286-E1

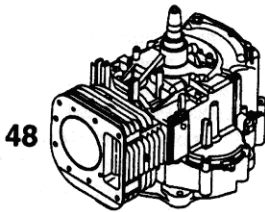
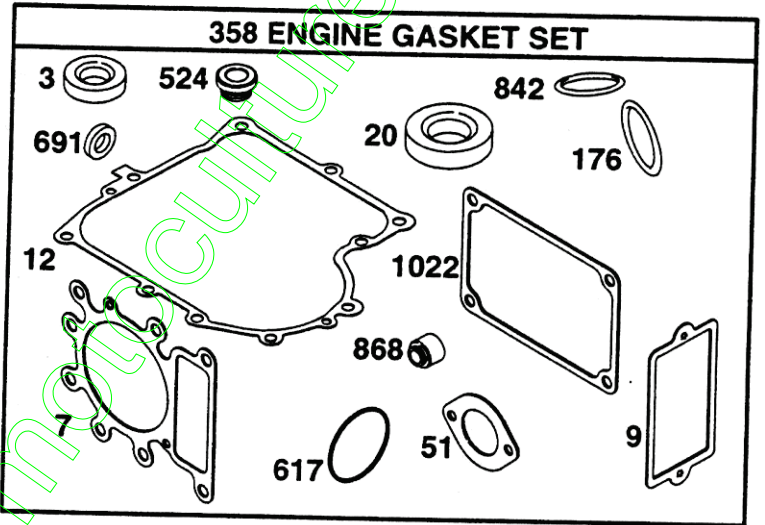
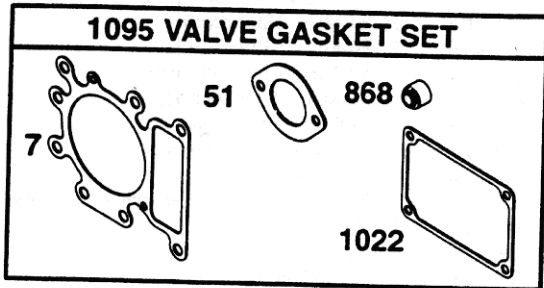
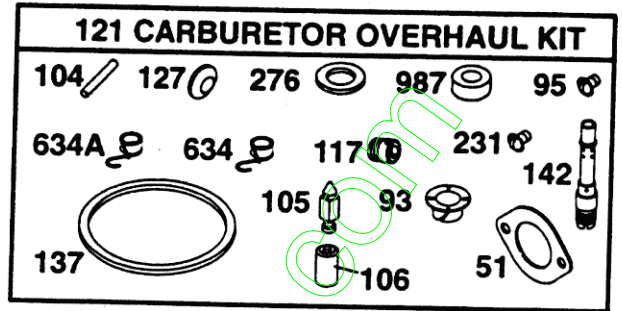
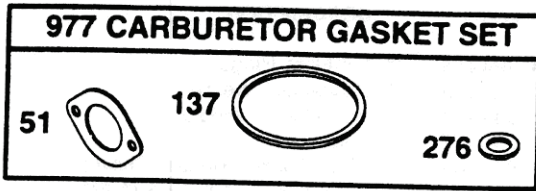

NIKKI

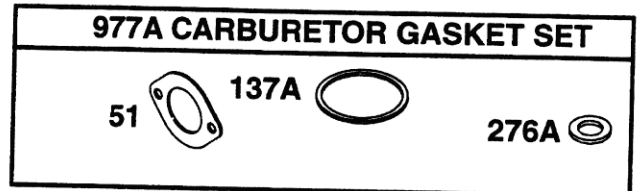
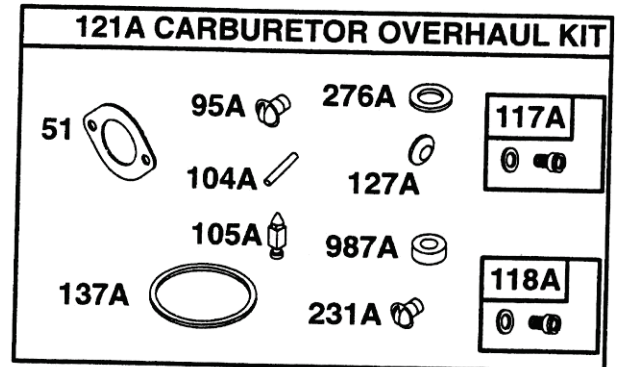
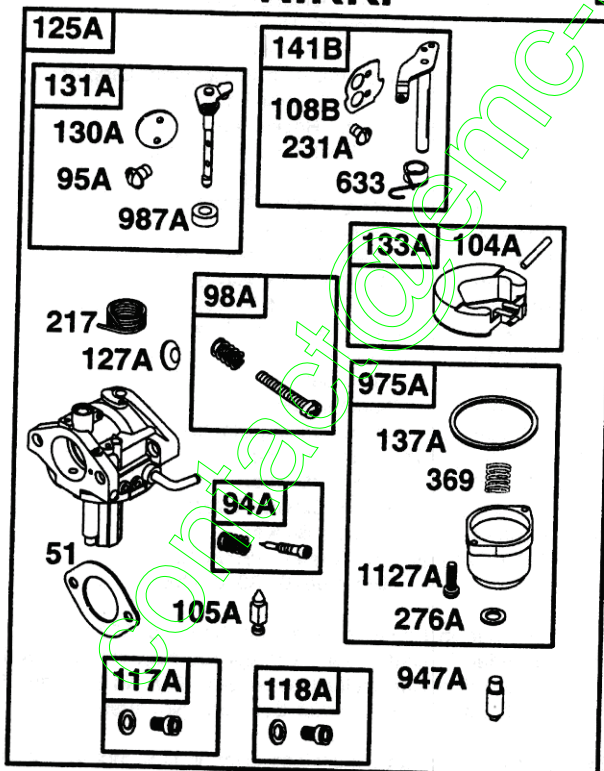

287707-1286-E1

REPAIR PARTS

TRACTOR- -MODEL NO. 917. 277020

BRIGGS & STRATTON ENGINE - - MODEL NUMBER 287707, TYPE NUMBER 1286-E1

KEY NO.	PART NO.	DESCRIPTION	KEY NO.	PART NO.	DESCRIPTION
1	496412	Cylinder Assembly	104A	694918	Ø Pin-Float Hinge
2	399265	Kit-Bushing/Seal (Magneto Side)	105	231855	Ø Valve-Float Needle
3	391086	• Seal-Oil (Magneto Side)	105A	694922	Ø Valve-Float Needle
4	494238	Sump-Engine	106	690577	Ø Seat-Inlet
5	691165	Head-Cylinder	108	690464	Valve-Choke (Manual Choke)
7	273280	•+ Gasket-Cylinder Head	108A	692344	Valve-Choke (Choke-A-Matic)
8	696126	Breather Assembly	108B	695419	Valve-Choke (Nikki Carburetor)
9	27803	• Gasket-Breather	117	692408	Ø Jet-Main (Standard)
10	691666	Screw (Breather Assembly)	117A	695415	Ø Jet-Main (Standard)
11	691328	Tube-Breather	118	692411	Jet-Main (High Altitude)
12	692226	• Gasket-Crankcase (.015" Thick, Standard)	118A	695416	Ø Jet-Main (High Altitude)
	692406	• Gasket-Crankcase (.005" Thick)	121	690191	Kit-Carburetor Overhaul
	692405	• Gasket-Crankcase (.009" Thick)	121A	695427	Kit-Carburetor Overhaul
13	690360	Screw (Cylinder Head)	125	690194	Carburetor
15	690946	Plug-Oil Drain	125A	---	Carburetor (Nikki) (Service with Walbro Carburetor)
16	690136	Crankshaft	127	695005	Ø Plug-Welch
20	291675	• Seal-Oil (PTO Side)	127A	690727	Ø Plug-Welch
22	692125	Screw (Crankcase Cover)	130	691750	Valve-Throttle
23	693557	Flywheel	130A	695418	Valve-Throttle
24	222698	Key-Flywheel	131	494379	Kit-Throttle Shaft
25	696397	Piston Assembly (Standard)	131A	695421	Kit-Throttle Shaft
	696398	Piston Assembly (.010" Oversize)	133	494381	Float-Carburetor
	696399	Piston Assembly (.020" Oversize)	133A	694914	Float-Carburetor
	696400	Piston Assembly (.030" Oversize)	137	281165	Ø‡ Gasket-Float Bowl
26	696403	Ring Set-Piston (Standard)	137A	695426	Ø‡ Gasket-Float Bowl
	696404	Ring Set-Piston (.010" Oversize)	141	495097	Kit-Choke Shaft (Manual Choke)
	696405	Ring Set-Piston (.020" Oversize)	141A	495931	Kit-Choke Shaft (Choke-A-Matic)
	696406	Ring Set-Piston (.030" Oversize)	141B	695420	Kit-Choke Shaft (Nikki)
27	691299	Lock-Piston Pin	142	692412	Ø Nozzle-Carburetor
28	498319	Pin-Piston (Standard)	146	691639	Key-Timing
	498320	Pin-Piston (.020" Oversize)	167	692297	Air Cleaner Stud Seal
29	692419	Rod-Connecting (Standard)	176	691917	• O-Ring Seal (Air Cleaner)
	499940	Rod-Connecting (.020" Undersize)	185	690958	Nut (Air Cleaner Base)
32	692852	Screw (Connecting Rod)	186	692317	Connector-Hose
33	495856	Valve-Exhaust	186A	691609	Connector-Hose
34	495857	Valve-Intake	187	691050	Line-Fuel (Cut to Required Length)
35	691279	Spring-Valve (Intake)	188	691693	Screw (Control Bracket)
36	691279	Spring-Valve (Exhaust)	192	691986	Adjuster-Rocker Arm
37	690456	Guard-Flywheel	202	691841	Link-Mechanical Governor
40	691752	Retainer-Valve	209	692208	Spring-Governor
43	691968	Slinger-Governor/Oil	217	695409	Spring-Choke Return
45	690564	Tappet-Valve	222	694042	Bracket-Control
46	697687	Camshaft	227	691374	Control Lever-Governor
48	496050	Short Block (311707-0028-E1 Replacement Engine)	231	691636	Ø Screw (Choke Valve)
50	690193	Manifold-Intake	231A	690718	Ø Screw (Choke Valve)
51	692137	•Ø‡+ Gasket-Intake	232	691842	Spring-Governor Link
53	690227	Stud (Carburetor)	238	691843	Cap-Valve
54	691148	Screw (Intake Manifold)	240	394358	Filter-Fuel
73	690492	Screen-Rotating	265	691024	Clamp-Casing
74	691655	Screw (Rotating Screen)	267	695134	Screw (Casing Clamp)
75	690582	Washer (Flywheel)	276	692255	Ø‡ Sealing Washer
78	690661	Screw (Flywheel Guard)	276A	695410	Ø‡ Sealing Washer
84	690343	Plug-Breather	287	691002	Screw (Dipstick Tube)
93	690602	Ø Bushing-Throttle Shaft	304	690844	Housing-Blower
94	498030	Kit-Idle Mixture			RPM Settings: Low Speed: 1900-2100 High Speed: 3000-3200
94A	695425	Kit-Idle Mixture			
95	691636	Ø Screw (Throttle Valve)			• Included in Engine Gasket Set, Key. No. 358
95A	690718	Ø Screw (Throttle Valve)			Ø Included in Carburetor Overhaul Kit, Key. No. 121 and 121A
98	495800	Kit-Idle Speed			‡ Included in Carburetor Gasket Set, Key. No. 977 and 977A
98A	695408	Kit-Idle Speed			+ Included in Valve Gasket Set, Key. No. 1095
104	690525	Ø Pin-Float Hinge			

NOTE: All component dimensions given in U.S. inches 1 inch = 25.4 mm

LIMITED WARRANTY ON CRAFTSMAN RIDING EQUIPMENT

For one (1) year from the date of purchase, if this Craftsman Riding Equipment is maintained, lubricated and tuned up according to the instructions in the owner's manual, Sears will repair or replace free of charge any parts that are found to be defective in material or workmanship according to the guidelines of coverage listed below. Sears will also provide free labor for these applicable warranted parts for the full year. During the first 30 days of purchase, there will be no charges to service the product at your home for issues covered by this warranty. (See exclusions below). For your convenience, IN HOME warranty service will still be available after the first 30 days of purchase, but a trip charge will apply. This charge will be waived if the Craftsman product is dropped off at an authorized Sears location. For the nearest authorized Sears location, please call 1-800-4-MY-HOME®. This warranty applies only while this product is within the United States.

This Warranty does not cover:

- Expendable items which become worn during normal use, including but not limited to blades, spark plugs, air cleaners, belts, and oil filters.
- Standard Maintenance Servicing, oil changes, or tune-ups
- Tire replacement or repair caused by punctures from outside objects, such as nails, thorns, stumps, or glass.
- Repairs necessary because of operator abuse, including but not limited to, damage caused by towing objects beyond the capability of the riding equipment, impacting objects that bend the frame or crankshaft, or over-speeding the engine.
- Repairs necessary because of operator negligence, including but not limited to, electrical and mechanical damage caused by improper storage, failure to use the proper grade and amount of engine oil, failure to keep the deck clear of flammable debris, or failure to maintain the equipment according to the instructions contained in the owner's manual.
- Engine (fuel system) cleaning or repairs caused by fuel determined to be contaminated or oxidized (stale). In general, fuel should be used within 30 days of its purchase date.
- Normal deterioration and wear of the exterior finishes, or product label replacement.
- Riding equipment used for commercial or rental purposes.

LIMITED WARRANTY ON BATTERY

For ninety (90) days from date of purchase, if any battery included with this riding equipment proves defective in material or workmanship and our testing determines the battery will not hold a charge, Sears will replace the battery at no charge. During the first 30 days of purchase, there will be no charges to replace the battery at your HOME. After the first 30 days, for your convenience, IN-HOME warranty service will still be available but a trip charge will apply. This charge will be waived if the Craftsman product is dropped off at an authorized Sears location. For the nearest authorized Sears location, please call 1-800-4-MY-HOME®.

This battery warranty applies only while this product is within the United States.

This warranty gives you specific legal rights, and you may also have other rights, which vary, from state to state.

Sears, Roebuck and Co., Dept. 817WA, Hoffman Estates, IL 60179

CRAFTSMAN®