

REPAIR PARTS MANUAL
MODEL NO. 277150
Lawn Tractor



HOW TO USE THIS MANUAL

This manual is designed to provide the customer with a means to identify the parts on his/her tractor when ordering repair parts. The illustrations may or may not represent the actual assemblies; therefore, it is not recommended to use this manual as a guide to assemble or disassemble the tractor. Some hardware and parts are drawn larger in order to more readily identify them.

Each tractor has its own model number.

The model number for your tractor can be found on the fender under the seat.

When ordering parts, always give the following information:

- Product - "Tractor"
- Model Number - "277150"
- Part Number
- Part Description

TABLE OF CONTENTS

SCHEMATIC	3
ELECTRICAL.....	4-5
CHASSIS.....	6-7
DRIVE.....	8-9
STEERING	10-11
SEAT	12
DECALS.....	13
ENGINE.....	14-15
MOWER LIFT	16-17
MOWER DECK	18-19
TRANSAXLE.....	20-21
ENGINE BREAKDOWN.....	22-27
WARRANTY	28

TRACTOR- -MODEL NO. 917. 277150

SCHEMATIC

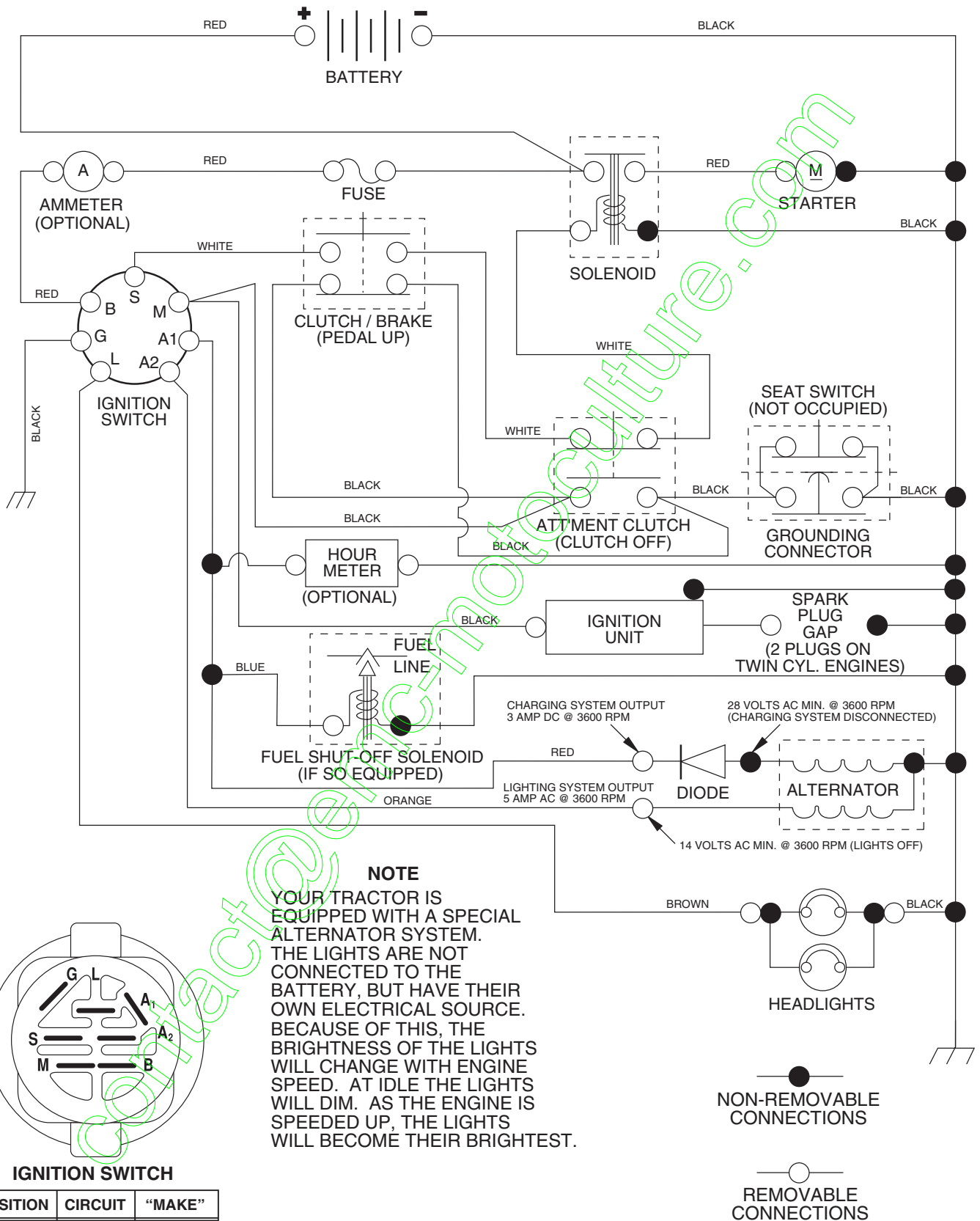

REPAIR PARTS

TRACTOR- -MODEL NO. 917. 277150

ELECTRICAL

KEY NO.	PART NO.	DESCRIPTION
1	163465	Battery
2	74760412	Bolt, Hex Head 1/4-20 unc x 3/4
8	176689	Box Battery Fender
16	176138	Switch, Interlock
21	175685	Harness, Light Socket (Includes 4152J)
22	4152J	Bulb, Light
24	4799J	Cable, Battery, 6 Gauge, Red, 11"
25	146147	Cable, Battery, 6 Gauge, Red, W/16 Wire
26	175158	Fuse
27	73510400	Nut Keps Hex 1/4-20 UNC
28	4207J	Cable, Ground, 6 Gauge, Black, 12"
29	121305X	Switch, Plunger
30	175566	Switch, Ignition
33	140403	Key, Ignition
40	179720	Harness, Ignition
41	71110408	Bolt, Hex Head, Fin. 1/4-20 x 1/2
42	131563	Cover, Terminal, Red
43	178861	Solenoid
48	140844	Adaptor Ammeter Rectangular
52	141940	Protection Wire Loop
90	180449	Cover Terminal Battery

NOTE: All component dimensions given in U. S. inches 1 inch = 25.4 mm

REPAIR PARTS

TRACTOR- -MODEL NO. 917. 277150

CHASSIS AND ENCLOSURES

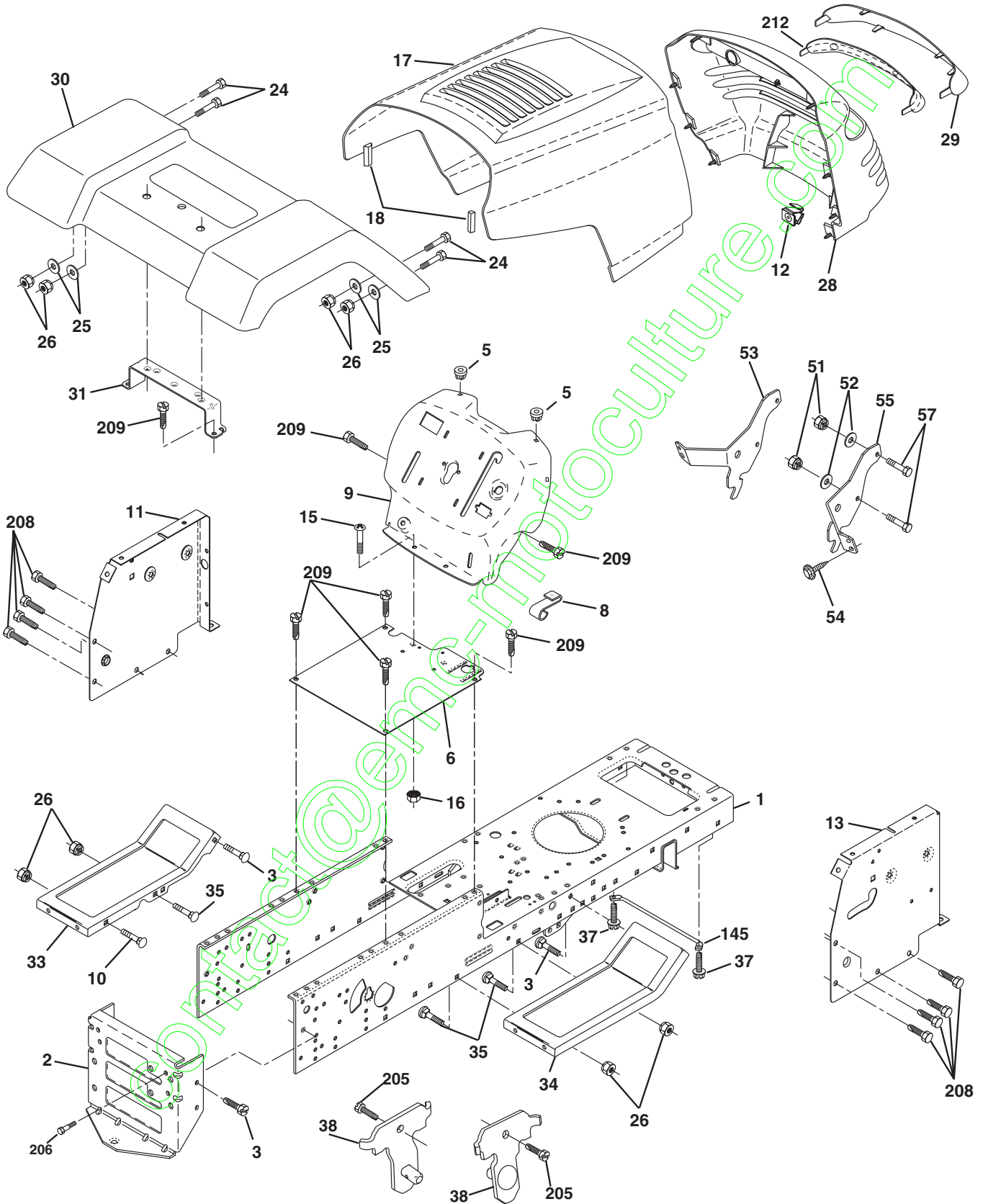

REPAIR PARTS

TRACTOR- -MODEL NO. 917. 277150

CHASSIS AND ENCLOSURES

KEY NO.	PART NO.	DESCRIPTION
1	174620	Chassis
2	176554	Drawbar
3	17060612	Screw 3/8-16 x 3/4
5	155272	Bumper Hood/Dash
6	174643X014	Saddle Slkscr Flt LT
8	155138	Clip Retainer Slide-On
9	168347X015	Dash
10	72140608	Bolt Rdhd Sqnk 3/8-16unc X 1
11	174996	Panel Dash LH
12	145660	Clip Tinnerman Grille P/L
13	172105X010	Panel Slkscr Dash RH
15	74180512	Screw Mach TRHD 5/16-18 unc x 3/4
16	73510500	Nut Keps 5/16-18 Unc
17	159639X558	Hood Asm
18	184921	Bumper Hood
24	74780616	Bolt Fin Hex 3/8-16 unc x 1 Gr. 5
25	19131312	Washer 13/32 X 13/16 x 12 Ga
26	73800600	Nut Hex Lock W/Ins. 3/8-16 Unc
28	179777	Grille/Lens Asm
29	150209X599	Lens Headlight Bar Clear
30	169465X558	Fender
31	136619	Bracket Fender Repl 109873x
33	179716X558	Footrest Pnt Lh
34	179717X558	Footrest Pnt Rh
35	72110606	Bolt Rdhd Sht Sqnk 3/8-16 x 3/4
37	17490508	Screw Thdrol 5/16-18 x 1/2
38	175710	Bracket Asm Pivot Mower Rear
51	73800400	Nut Lock Hex w/Ins 1/4-20
52	19091416	Washer 9/32 x 7/8 x 16 Ga.
53	144697	Bracket, Grille LH
54	161464	Screw
55	144696	Bracket, Grille RH
57	74780412	Bolt Hex 1/4-20 x 3/4
145	156524	Rod Pivot Chassis/Hood
205	17490608	Screw Thdrol 3/8-16 x 1/2
206	170165	Bolt Shoulder 5/16-18
208	17670608	Screw thdrol 3/8-16 x 1/2
209	17000612	Screw Hex Wsh Thdrol 3/8-16
212	156494	Insert Lens Reflective
-	5479J	Plug Button Blk 359 Dia Choke

NOTE: All component dimensions given in U. S.
inches 1 inch = 25.4 mm

REPAIR PARTS

TRACTOR- -MODEL NO. 917. 277150

DRIVE

KEY NO.	PART NO.	DESCRIPTION	KEY NO.	PART NO.	DESCRIPTION
1	-----	Transaxle Dana D4360-139 (Order parts from transaxle Manufacturer)	49	123205X	Retainer Belt Style Spring
2	146682	Spring Return Brake T/a Zinc	50	72110612	Bolt 3/8-16 x 1-1/2 Gr. 5
3	123666X	Pulley Transaxle 18/20" tires	51	73680600	Nut Crownlock 3/8-16 UNC
4	12000028	Ring Retainer # 5100-62	52	73680500	Nut Crown Lock 5/16-18
5	121520X	Strap Torque 30 Degrees	53	105710X	Link Clutch 7 66
6	17000512	Screw 5/16-18 x 3/4	55	105709X	Spring Return Clutch 6 75
7	162240	Bracket Saddle Shift T/a	56	17060620	Screw 3/8-16 x 1-1/4
8	131679	Rod Shf Sdl LY/YT Str Blk	57	160855	V-Belt Gd Drive 9530
10	76020416	Pin Cotter 1/8 x 1 Cad	59	169691	Keeper Belt Centerspan
11	105701X	Washer Plate 388 Sq Hole	61	17120614	Screw 3/8-16 x .875
12	19151216	Washer 15/32 x 3/4 x 16ga	62	8883R	Cover Pedal Blk Round
13	74550412	Bolt 1/4-28unf Gr8 W/Patch	63	180219	Pulley Eng
14	10040400	Washer Lock Hvy Helical 1/4	64	173937	Bolt Hex 7/16-20 x 4 Gr 5
15	74490544	Bolt Hex Flghd 5/16-18 x Gr. 5	65	10040700	Washer Lock Hlcl Spr 7/16
18	74780616	Bolt Fin Hex 3/8-16 UNC x 1 Gr. 5	66	154778	Keeper Belt Engine FP
19	73800600	Nut Lock Hex W/Ins. 3/8-16 Unc	70	180218	Guide Belt Mower Drive RH
21	106933X	Knob Rd 1/2-13 Plstc Thds	74	109502X	Spacer Axle
22	130804	Rod Brake Blk Zinc 26 840	75	121749X	Washer 25/32 x 1-1/4 x16 Ga
24	73350600	Nut Hex Jam 3/8-16 Unc	76	12000001	E-ring #5133-75
25	106888X	Spring Rod Brake 2 00 Zinc	77	123583X	Key Square 2 0 x 1845/ 1865
26	19131316	Washer 13/32 x 13/16 x 16 Ga.	78	121748X	Washer 25/32 x1-5/8 x 16 Ga
27	76020412	Pin Cotter 1/8 x 3/4 Cad	79	2228M	Key Woodruff #9 3/16 x 3/4
28	175765	Rod Brake Parking Lt/Yt	96	4497H	Retainer Spring 1
29	71673	Cap Brake Parking	112	19091210	Washer 9/32 x 3/4 x 10 Ga
30	174973	Bracket Mtg Transaxle	113	127285X	Strap Torque LH LT
32	74760512	Bolt Hex Hd 5/16-18unc x 3/4	116	72140608	Bolt 3/8-16 x 1
34	175578	Shaft Asm Pedal Foot Nibbed	120	73900600	Nut Lock Flg 3/8-16
35	120183X	Bearing Nylon Blk 629 Id	150	175456	Spacer Retainer
36	19211616	Washer 21/32 x 1 x 16 Ga	151	19133210	Washer 13/32 x 2 x 10 Ga.
37	1572H	Pin Roll 3/16 x 1"	170	178394	Keeper Belt Transaxle Gear
38	179114	Pulley Composite Flat	202	72110614	Bolt Carr. Sh 3/8-16 x 1-3/4 Gr. 5
39	74760648	Bolt Fin Hex 3/8-16 UNC x 3 Gr. 5	212	145212	Nut Hex Flange Lock
41	175556	Keeper Belt Idler	250	17060612	Screw 3/8-16 x 3/4
47	127783	Pulley Idler V Groove Plastic	263	17000612	Screw 3/8-16 x 3/4
48	154407	Bellcrank Asm. Clutch	269	182402	Guard Muffler

NOTE: All component dimensions given in U. S.
inches 1 inch = 25.4 mm

REPAIR PARTS

TRACTOR- -MODEL NO. 917. 277150

STEERING ASSEMBLY

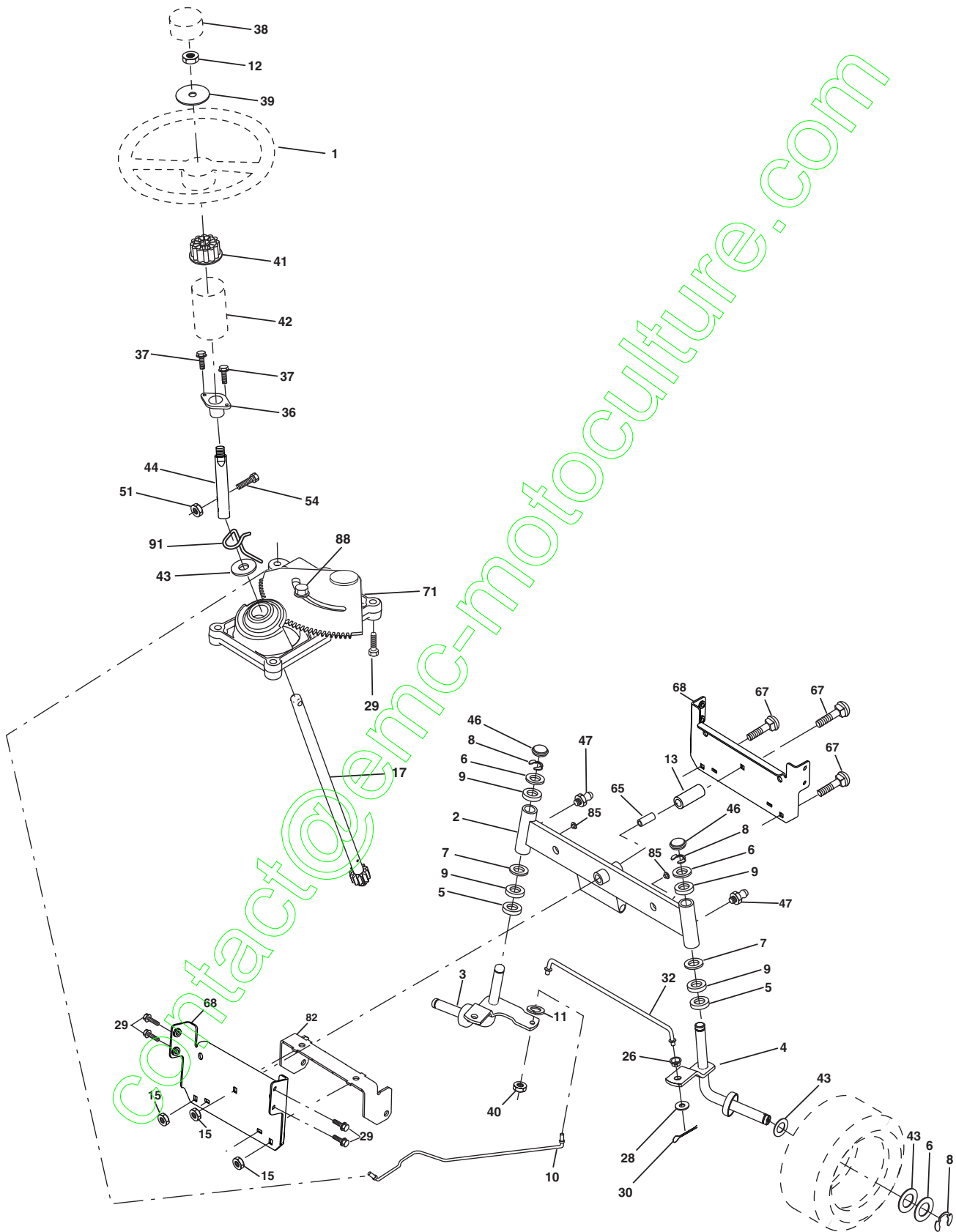

REPAIR PARTS

TRACTOR- -MODEL NO. 917. 277150

STEERING ASSEMBLY

KEY NO.	PART NO.	DESCRIPTION
1	140044X428	Steering Wheel
2	175131	Axle Assembly
3	169840	Spindle Assembly, L.H.
4	169839	Spindle Assembly, R.H.
5	6266H	Bearing, Race, Thrust, Hardened
6	121748X	Washer 25/32 x 1-5/8 x 16 Gauge
7	19272016	Washer 27/32 x 1-1/4 x 16 Gauge
8	12000029	Ring, Klip
9	3366R	Bearing, Steering Column
10	175121	Draglink
11	10040600	Washer, Lock
12	73940800	Nut Hex Jam Toplock 1/2-20 Unf
13	136518	Spacer Bearing Axle Front
15	145212	Hexflange Lock
17	180641	Shaft Assembly, Steering
26	126847X	Bushing, Link, Drag
28	19131416	Washer 13/32 x 7/8 x 16 Gauge
29	17060612	Screw, 3/8-16 x 3/4
30	76020412	Pin
32	130465	Rod, Tie
36	155099	Bushing, Steering
37	152927	Screw
38	140045X428	Cap, Steering Wheel
39	19183812	Washer 9/16 x 2-3/8 12 Gauge
40	7810H	Gripco Nut
41	100711L	Adaptor, Steering Wheel
42	145054X428	Boot, Steering
43	121749X	Washer 25/32 x 1-1/4 x 16 Gauge
44	180640	Shaft Extension Steering
46	121232X	Cap, Spindle
47	183226	Fitting, Grease
51	73540400	Nut Crownlock 1/4-28
54	71130420	Bolt Hex 1/4-28unf x 1-1/4 Gr. 8
65	160367	Spacer Brace Axle
67	72140618	Bolt, Rdhd Sq 3/8-16 UNC x 2-1/4
68	169827	Axle, Brace
71	175146	Steering Asm
82	169835	Bracket Susp Chassis Front
85	133835	Fastener Christmas Tree
88	175118	Shoulder Bolt
91	175553	Clip Steering

NOTE: All component dimensions given in U. S. inches
1 inch = 25.4 mm

REPAIR PARTS

TRACTOR- -MODEL NO. 917. 277150

SEAT ASSEMBLY

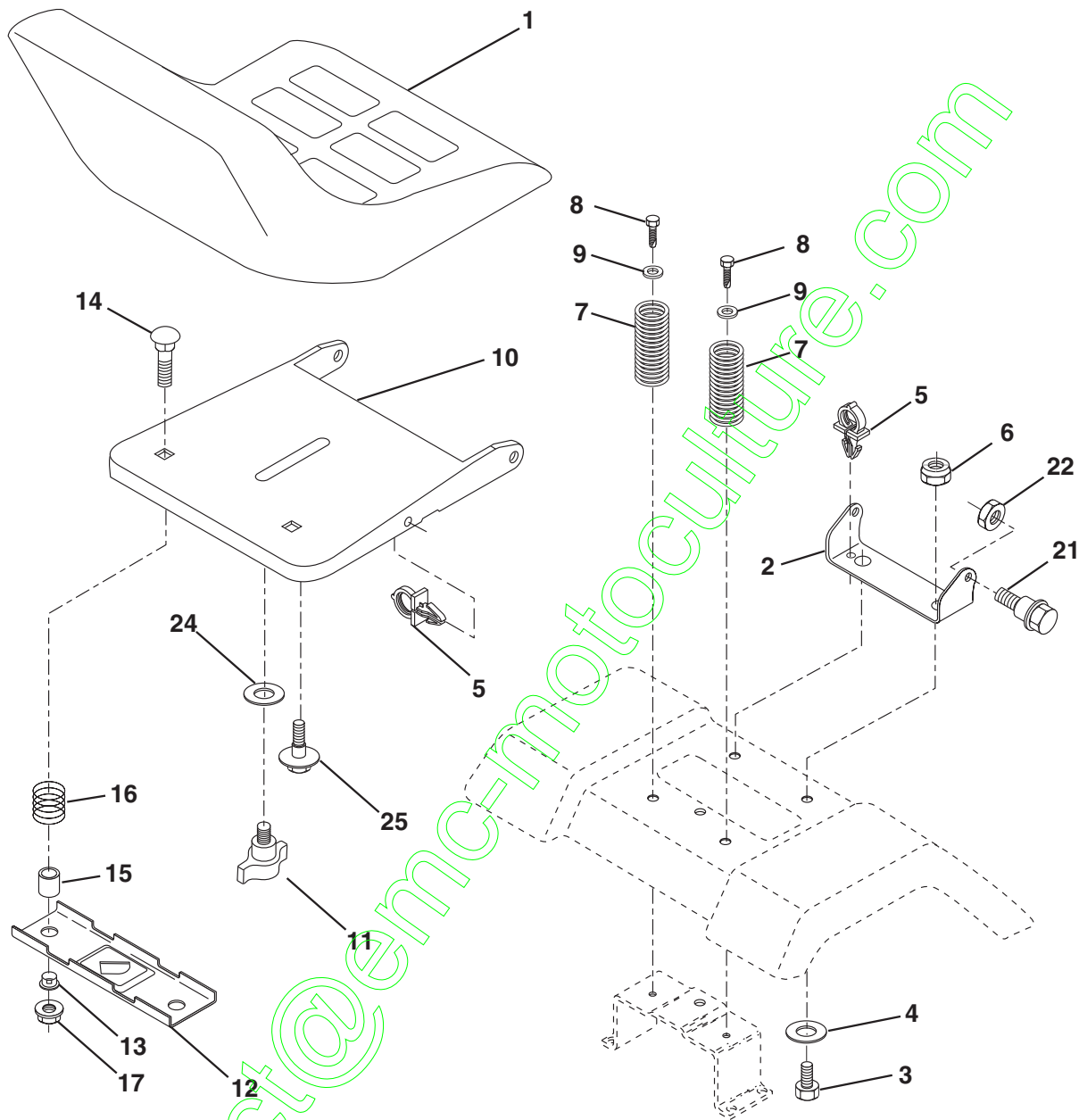

KEY NO.	PART NO.	DESCRIPTION
1	127427	Seat
2	140551	Bracket Pvt St
3	71110616	Bolt Fin Hex 3/8-16unc x 1
4	19131610	Washer Flat 13/32 x1 x10 Ga
5	145006	Clip Push-In Hinged
6	73800600	Locknut Hex W/Wsh 3/8-16
7	124181X	Spring Seat Cprsn 2 250 Blk
8	17000616	Screw 3/8-16 x 1
9	19131614	Washer 13/32 x 1 x 14 Ga
10	182493	Pan Seat
11	166369	Knob Seat Adj. Wingnut
12	121246X	Bracket Mounting Switch

KEY NO.	PART NO.	DESCRIPTION
13	121248X	Bushing Snap Blk Nyl 50 Id
14	72050412	Bolt Rdhd Sht 1/4-20x1-1/2
15	134300	Spacer Split 28x 96 Yel Zinc
16	121250X	Spring Cprsn 1 27 Blk Pnt
17	123976X	Nut Lock 1/4 Lge Flg Gr 5
21	171852	Bolt Shld 5/16-18 Unc
22	73800500	Nut Lock Hex W/Ins 5/16-18
24	19171912	Washer 17/32 x1-3/16x12 Ga
25	127018X	Bolt Shoulder 5/16-18 x 62

NOTE: All component dimensions given in U. S. inches 1 inch = 25.4 mm

REPAIR PARTS

TRACTOR- -MODEL NO. 917. 277150

DECALS

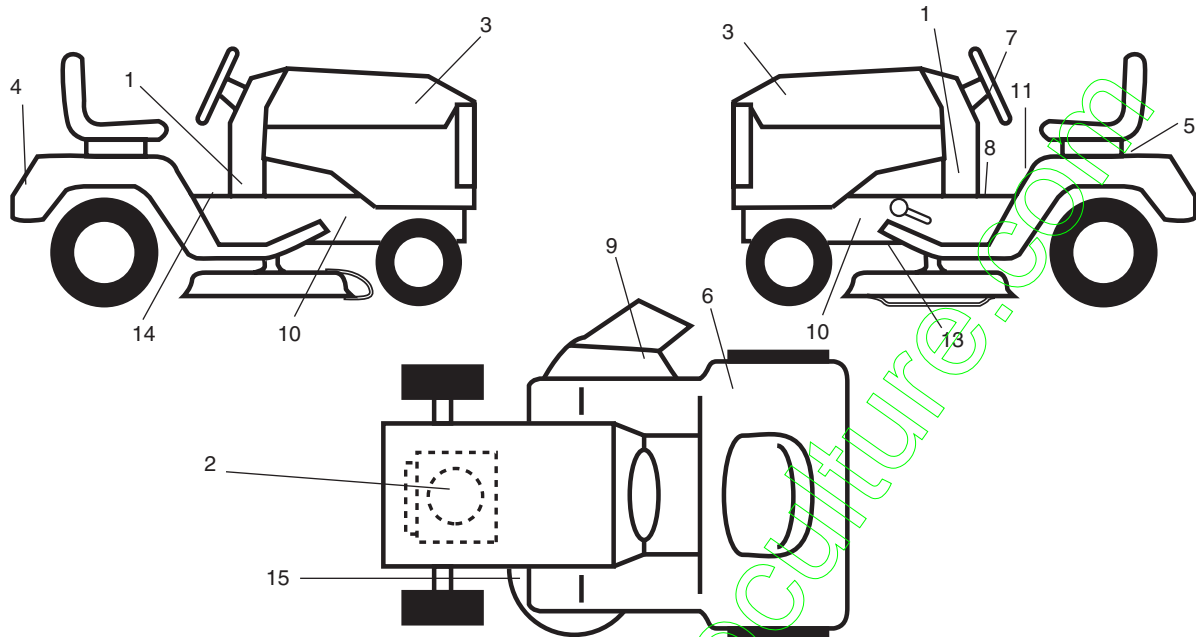

KEY NO.	PART NO.	DESCRIPTION	KEY NO.	PART NO.	DESCRIPTION
1	177109	Decal Lower Dash	11	145498	Decal Read Owners Manual
2	185845	Decal Engine	13	146046	Decal V-Belt Dr Sch tractor
3	171704	Decal Hood	14	159737	Decal, Brake/Clutch
4	163204	Decal Fender	15	136832	Decal V-Belt sch
5	145005	Decal Battery Danger	--	138311	Decal Handle Lft Height Adjust (Lift Handle)
6	180432	Decal, Fend 100/CE	--	162598	Decal, Drawbar
7	172275	Decal Steering	--	186531	Manual Oper, Euro
8	140837	Decal, Brake Park	--	186532	Manual Oper, Scan
9	182166	Decal, Cut Finger	--	186533	Manual, Parts
10	159736	Decal, Chassis Hot Muffler			

WHEELS AND TIRES

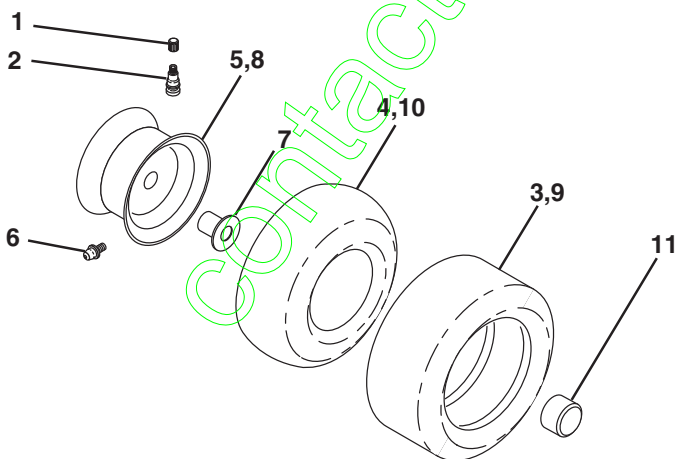

KEY NO.	PART NO.	DESCRIPTION
1	59192	Cap Valve Tire
2	65139	Stem Valve
3	106222X	Tire F Ts 15 X 6 0 - 6 Service
4	59904	Tube Front (Service Item Only)
5	106732X624	Rim Asm 6"front Service
6	278H	Fitting Grease (Front Wheel Only)
7	9040H	Bearing Flange (front Wheel Only)
8	106108X624	Rim Asm 8"rear Service
9	124635X	Tire Rear
10	7152J	Tube Rear (Service Item Only)
11	104757X428	Cap Axle Blk 1 50 X 1 00
--	144334	Sealant, Tire (10 oz. Tube)

NOTE: All component dimensions given in U. S. inches 1 inch = 25.4 mm

REPAIR PARTS

TRACTOR- -MODEL NO. 917. 277150

ENGINE

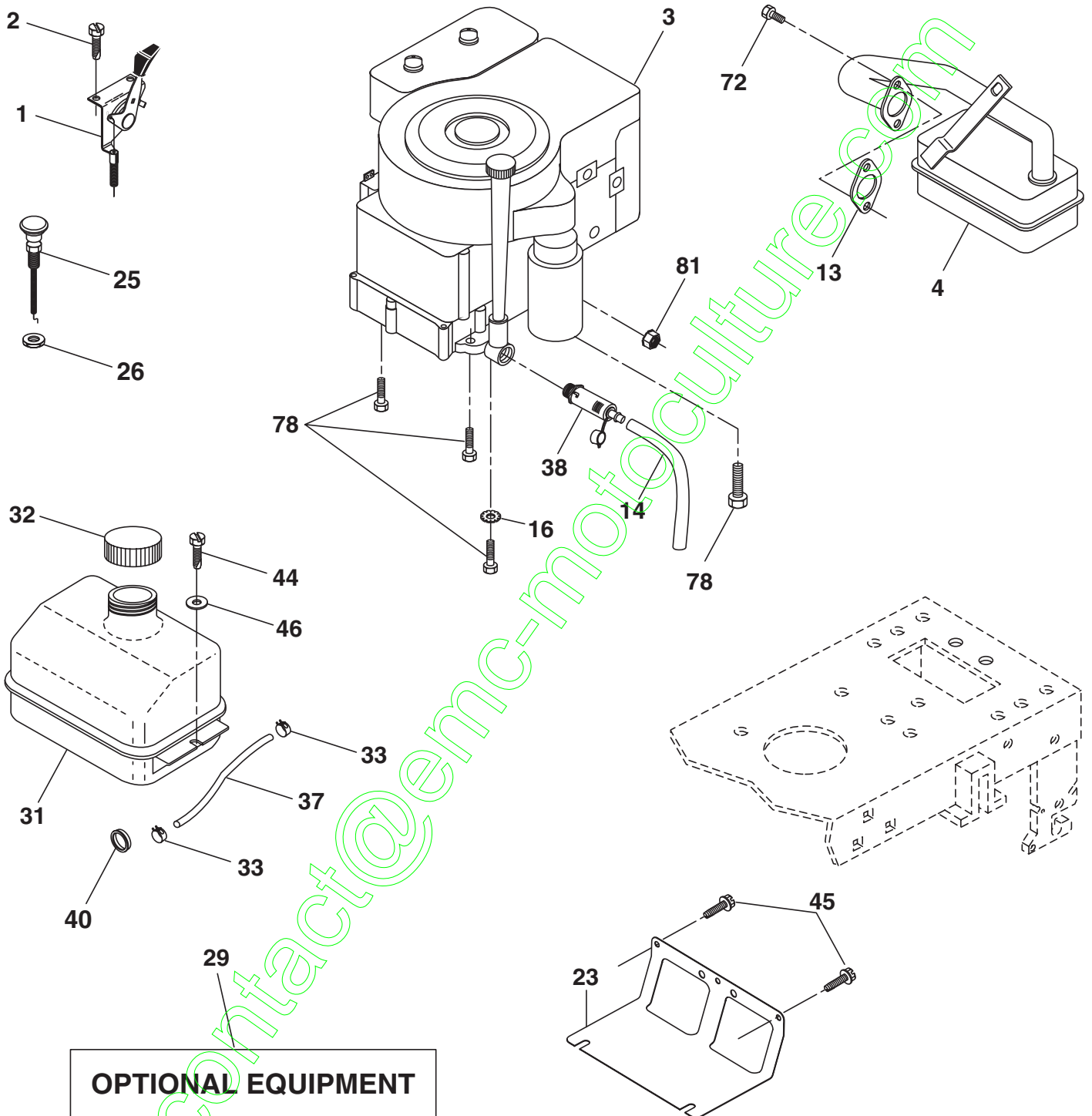

OPTIONAL EQUIPMENT
Spark Arrester

REPAIR PARTS

TRACTOR- -MODEL NO. 917. 277150

ENGINE

KEY NO.	PART NO.	DESCRIPTION
1	170551	Control Th/ch
2	17720408	Screw Hex Thd Cut 1/4-20 x 1/2
3	-----	Engine Briggs Model 282H07-0239-E1 (Order parts from Engine Manufacturer)
4	137352	Muffler
13	165291	Gasket Eng 1 3/13 Id Tin Plated
14	148456	Tube Easy Oil Drain
16	11050600	Washer Lock Ext Tooth 3/8
23	169837	Shield Browning
25	180945	Control Choke 1 Cyl
26	73920600	Nut Keps 3/8-24 Unf
29	137180	Kit Spark Arrestor (Flat Scrn)
31	184900	Tank Fuel Front 1 25
32	140527	Cap Asm Fuel
33	123487X	Clamp Hose Blk
37	137040	Line Fuel 20"
38	181654	Plug Oil Drain
40	124028X	Bushing Snap Nyl Blk Fuel Line
44	17670412	Screw Hexwsh Thdrol 1/4-20 x 3/4
45	17000612	Screw Hex Wsh Thdrol 3/8-16
46	19091416	Washer 9/32 x 7/8 x 16 ga
72	183906	Screw Socket Head 5/16-18 x 1
78	17060620	Screw 3/8-16 x 1-1/4
81	73510400	Nut Keps Hex 1/4-20 UNC

NOTE: All component dimensions given in U. S. inches 1 inch = 25.4 mm

REPAIR PARTS

TRACTOR- -MODEL NO. 917. 277150

MOWER LIFT

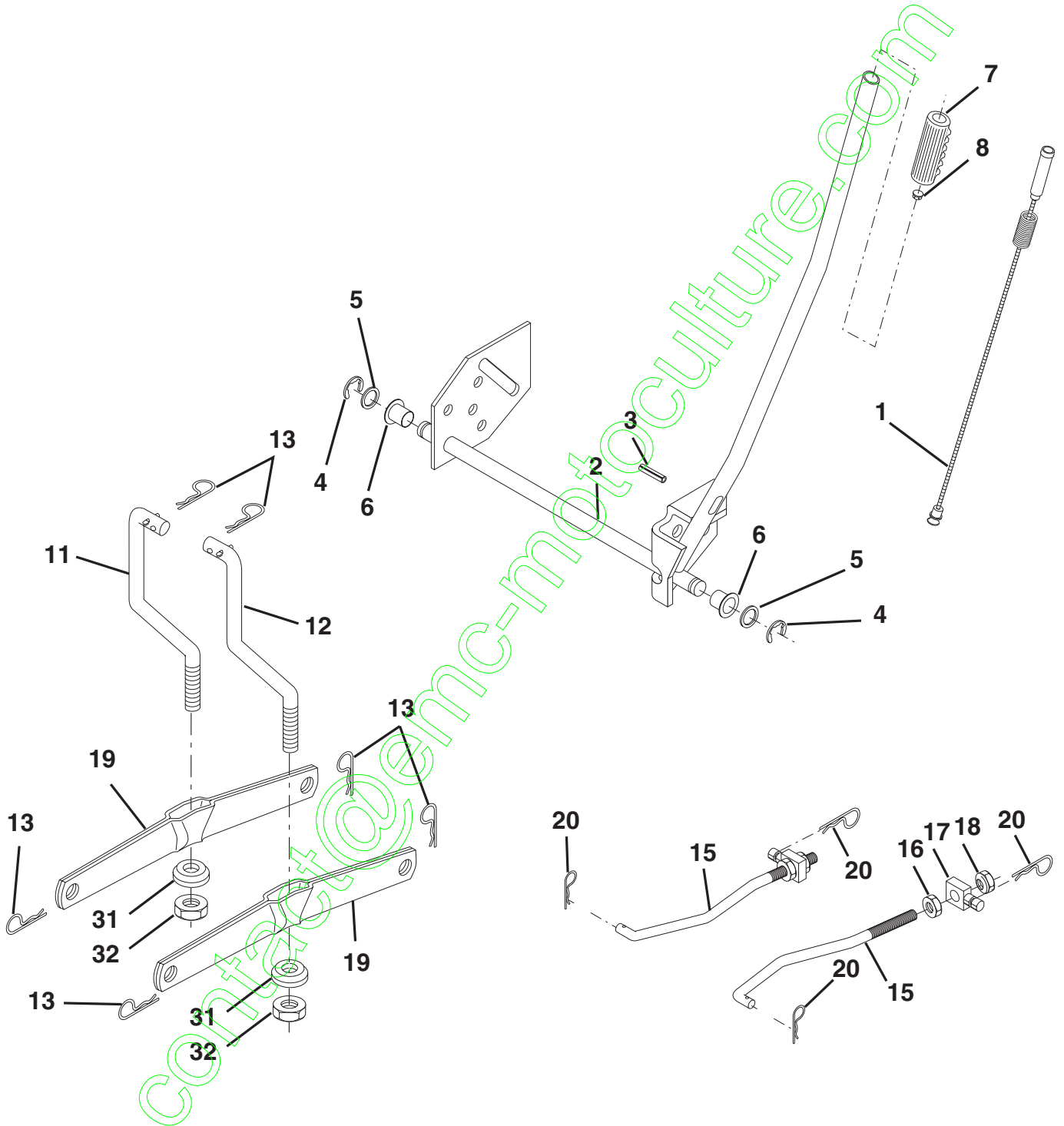

REPAIR PARTS

TRACTOR- -MODEL NO. 917. 277150

MOWER LIFT

KEY NO.	PART NO.	DESCRIPTION
1	159460	Wire Asm Inner W/plunger
2	159471	Shaft Asm Lift
3	105767X	Pin Groove 1 500 Zinc
4	12000002	E Ring #5133-62
5	19211621	Washer Pltd 21/32 X 1 X 21ga
6	120183X	Bearing Nylon Blk 629 Id
7	125631X	Grip Handle Fluted Blk
8	122365X	Button Plunger Red
11	139865	Link Lift LH
12	139866	Link Lift RH
13	4939M	Retainer Spring
15	173288	Link Front
16	73350800	Nut Jam Hex 1/2-13 Unc
17	175689	Trunnion Blk Zinc
18	73800800	Nut Lock w/Wsh 1/2-13 UNC
19	139868	Arm Suspension Rear
20	163552	Retainer Spring Zinc
31	169865	Bearing Pvt Lift
32	73540600	Nut Crownlock 3/8-24

NOTE: All component dimensions given in U. S. inches 1 inch = 25.4 mm

REPAIR PARTS

TRACTOR- -MODEL NO. 917. 277150

MOWER

KEY NO.	PART NO.	DESCRIPTION	KEY NO.	PART NO.	DESCRIPTION
1	170280	Mower Housing Assembly	69	76020312	Pin, Cotter 3/32 x 3/4
2	72140506	Bolt, Carriage 5/16-18 x 3/4	86	7631J	Runner, LH
3	138017	Bracket Asm. Fram Sway Bar	87	128772	Runner, RH
4	169970	Bracket, Asm. Deck Sway Bar	88	19111216	Washer 11/32 x 3/4 x 16 Ga
5	4939M	Retainer, Spring	89	19131612	Washer 13/32 x 1 x 12 Ga
6	178024	Bar Sway Deck	96	74930620	Bolt 3/8-16 x 1-1/4
8	850857	Bolt, Hex 3/8-24 x 1-1/4 Gr 8	97	73930600	Nut Centerlock 3/8-16
9	10030600	Washer, Lock, Hlcl Sprg 3/8	98	19132016	Washer 13/32 x 1-1/4 x 16 Ga.
10	140296	Washer, Hard Blade Mower Vented	99	10040600	Washer Lock Hvy HLCL Spr. 3/8
11	134148	Blade, 38" Mulching Std (For mulching mowers only)	100	135651	Nut Wing
13	137645	Shaft and Bearing Assembly (Includes Key Number 15)	101	132803	Cover Asm Mulch
14	128774	Mandrel Housing, Vented	107	133502	Spacer, Retainer
15	110485X	Ball Bearing, Mandrel	108	133503	Stiffener, Idler Arm
16	174493	Stripper, Mower, Vented	109	74760640	Bolt, Hex Head 3/8-16 x2-1/2
19	132827	Bolt, Shoulder	110	142587	Upstop Deck Front 38"
21	73680500	Nut, Crownlock 5/16-18	113	17060512	Screw 5/16-18 x 3/4
23	137607	Bracket, Mower Deflector	122	131289	Rod, Brake, LH
24	105304X	Cap, Sleeve	123	169971	Rod, Brake, RH
25	123713X	Spring, Deflector	146	165891	Bolt Carriage Idler
26	110452X	Nut, Push	148	169022	Spring Return Idler
27	106736X428	Shield, Deflector	149	165898	Retainer Spring Yellow Zinc
28	19111016	Washer 11/32 x 3/4 x 16 Ga	150	19091216	Washer 9/32 x 3/4 x 16 Ga.
29	106735X	Rod, Hinge	151	169670	Bracket Clutch
30	173984	Screw, Thdro	152	172758	Cable Clutch 38 In
31	129963	Washer, Spacer	153	169674	Washer Flat 3/8" Type B
32	153532	Pulley, Mandrel	154	169675	Spring Retainer
33	178342	Nut, Flangelock 9/16	155	169671	Spring Retention Lever
36	131494	Pulley, Idler, Flat	156	169672	Spacer
40	73680600	Nut Crownlock 3/8-16	157	169669	Rod Clutch
45	4497H	Retainer, Spring	158	17720408	Screw Hex Thd Cut 1/4-20 x 1/2
53	130840	Brake Assembly	--	130794	Mandrel Assembly (Includes Housing, Shaft and Shaft Hardware Only-Pulley Not Included)
54	178515	Washer Hardened	--	181209	Replacement Mower, Complete
55	133840	Idler Arm Assembly			
56	165723	Spacer, Retainer			
67	149846	Knob			
68	180214	Belt			

NOTE: All component dimensions given in U.S. inches
1 inch = 25.4 mm

REPAIR PARTS

TRACTOR- -MODEL NO. 917. 277150

DANA TRANSAXLE - MODEL NUMBER D4360-139

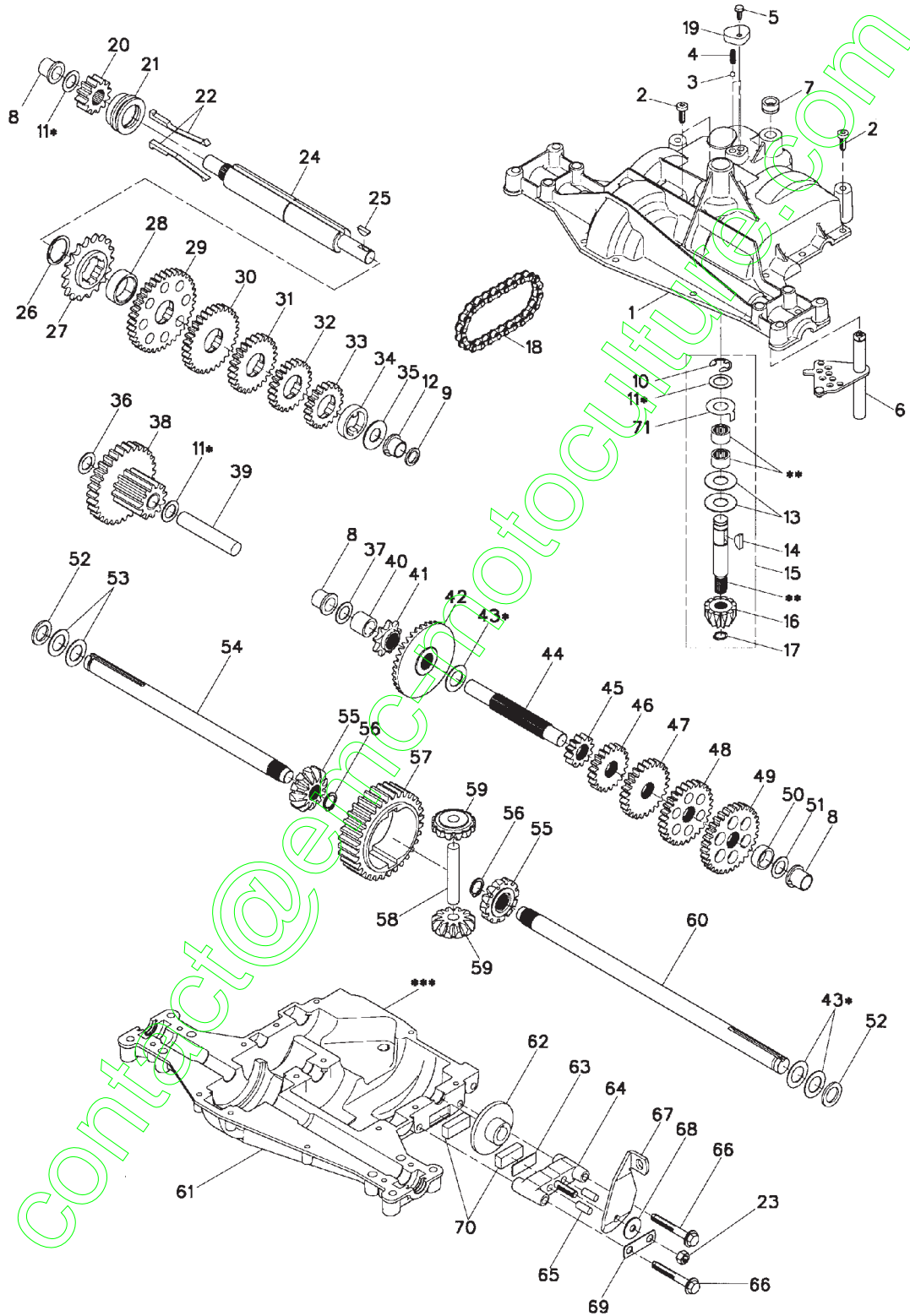

REPAIR PARTS

TRACTOR- -MODEL NO. 917. 277150

DANA TRANSAXLE - MODEL NUMBER D4360-139

KEY NO.	PART NO.	DESCRIPTION	KEY NO.	PART NO.	DESCRIPTION
1	170981	Housing, Upper	41	105928X	Sprocket, 9T
2	2274J	Screw, Tapping, 1/4-20 X .734	42	170988	Gear, Bevel, 36T
3	134400	Ball, Detent	43	134394 *	Assy, Kit, Shim, .750 Shaft
4	105904X	Spring, Detent	44	120473X	Shaft, Drive
5	160940	Screw, Tapping, No. 10-24 X .482	45	142678	Gear, Spur, 12T
6	138235	Assy, Kit, Shifter	46	124641 X	Gear, Spur, 20T
7	108727X	V-Ring	47	106589X	Gear, Spur, 25T
8	148266	Bearing, Flange	48	120408X	Gear, Spur, 28T
9	148269	Seal, Oil	49	105937X	Gear, Spur, 31T
10	2225J	Ring, Retaining	50	105936X	Spacer, .781 X 1.00 X .375
11	134793 *	Assy, Kit, Shim, .625 Shaft	51	2226J	Washer, Plain, .632 X 1.00 X .060
12	148268	Bearing, Flange	52	134401	Washer, Neoprene
13	120415X	Washer, Plain, .632 X 1.38 X .046	53	2264J	Washer, Plain, .758 X 1.25 X .031
14	142674	Key, Woodruff, No. 9	54	160946	Axle, LH
15	170983	Assy, Kit, Input Shaft	55	170990	Gear, Miter, T, Splined
16	170986	Pinion, Bevel, 12T	56	160948	Ring, Retaining
17	105909X	Ring, Retaining	57	110071X	Gear, Spur, 32T
18	105910X	Chain, 24 Pitches	58	120952X	Shaft, Cross
19	160942	Cover, Detent	59	170991	Gear, Miter, 1 2T, Idler
20	160943	Gear, Spur, 1 2T	60	160950	Axle, RH
21	148267	Collar, Clutch	61	170992	Housing, Lower
22	138236	Assy, Kit, Clutch Keys	62	7294J	Disc, Brake
23	73810500	Nut, Lock, 5/16-24	63	108989X	Spacer, Brake Puck
24	142676	Shaft, Intermediate	64	160952	Jaw, Brake
25	2244J	Key, Woodruff, No. 61	65	120954X	Pin, Dowel
26	105916X	Ring, Retaining	66	160953	Screw, Tapping, 5/16-18 X 2.35
27	120470X	Sprocket, 1 8T	67	138244	Lever, Actuating
28	110070X	Spacer, 1. 131 X 1.45 X .494	68	108996X	Washer, Plain, .321 X 1.00 X .055
29	142677	Gear, Spur, 37T	69	160954	Bracket, Anti-Rotation
30	124644X	Gear, Spur, 30T	70	120951X	Puck, Friction
31	108980X	Gear, Spur, 25T	71	174256	Washer, Anti Rotation
32	120406X	Gear, Spur, 22T	72	120416X	Grease
33	134796	Gear, Spur, 1 9T			
34	134797	Spacer, 1. 133 X 1.50 X .375			
35	105925X	Washer, Plain, .640 X 1.37 X .061			
36	2228J	Washer, Plain, .632 X 1.00 X .046			
37	170987	Washer, Plain, .632 X 1.00 X .031			
38	174255	Assy, Gear, Comb., 12T & 30T			
39	124639X	Shaft, Idler			
40	120472X	Spacer, .633 X .87 X .755			

NOTE: All component dimensions given in U.S. inches
1 inch = 25.4 mm

* Use in various combinations to maintain proper clearances.

** Order Key No. 15.

*** Silicone Sealant to be applied between Upper and Lower Housings (use Loctite Ultra Gray Silicone 5699 or equivalent).

REPAIR PARTS

TRACTOR- -MODEL NO. 917. 277150

BRIGGS & STRATTON ENGINE - - MODEL NUMBER 282H07, TYPE NUMBER 0239-E1

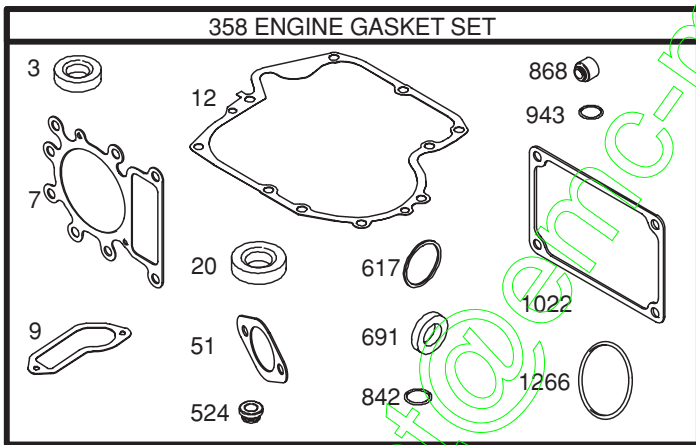
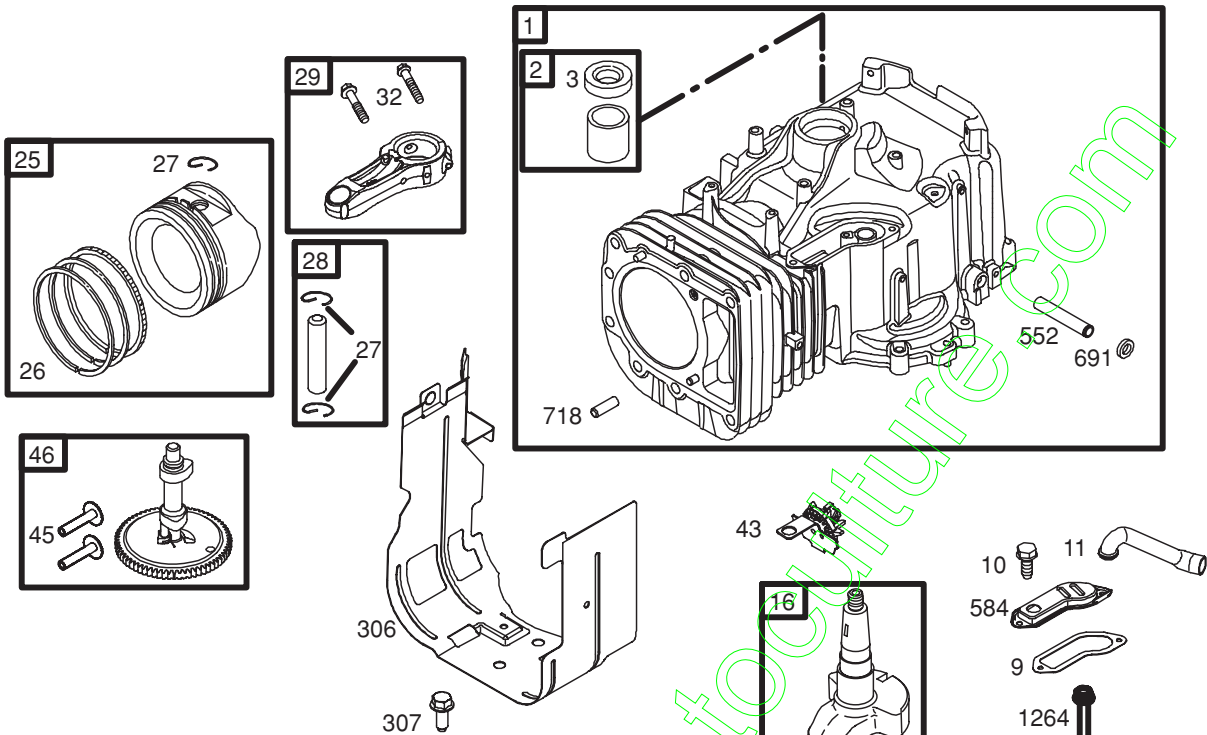

1019 LABEL KIT

1058 OWNER'S MANUAL

1036 EMISSION LABEL

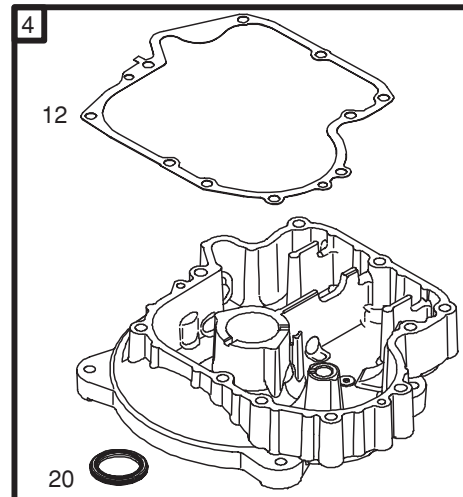

REPAIR PARTS

TRACTOR- -MODEL NO. 917. 277150

BRIGGS & STRATTON ENGINE - - MODEL NUMBER 282H07, TYPE NUMBER 0239-E1

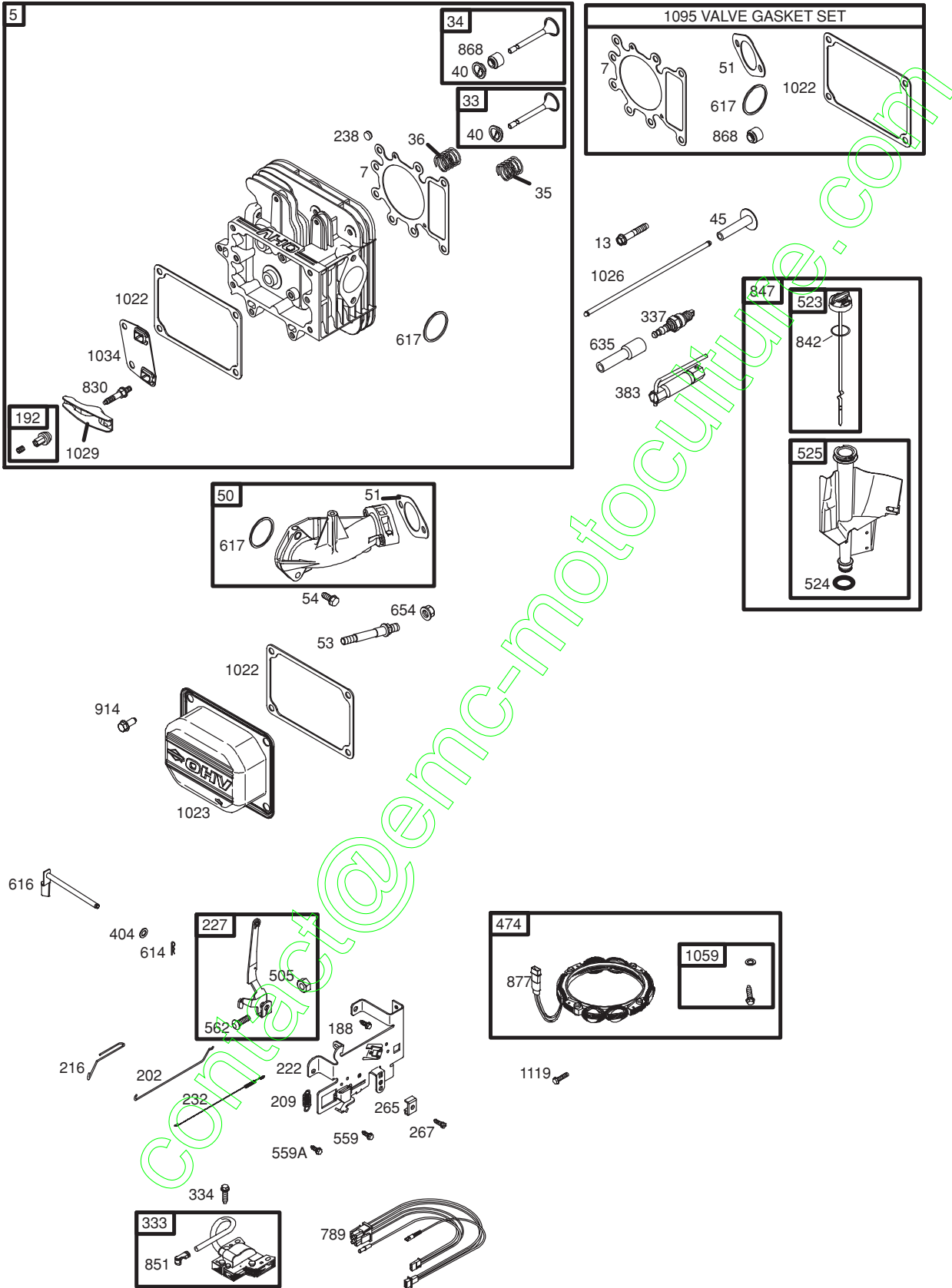

REPAIR PARTS

TRACTOR- -MODEL NO. 917. 277150

BRIGGS & STRATTON ENGINE - - MODEL NUMBER 282H07, TYPE NUMBER 0239-E1

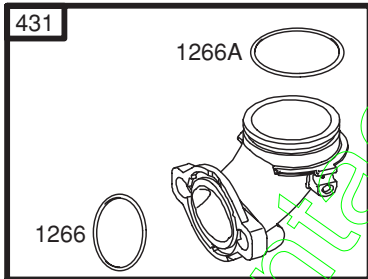
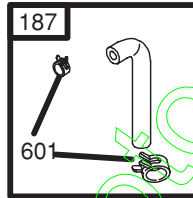
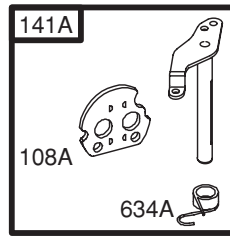
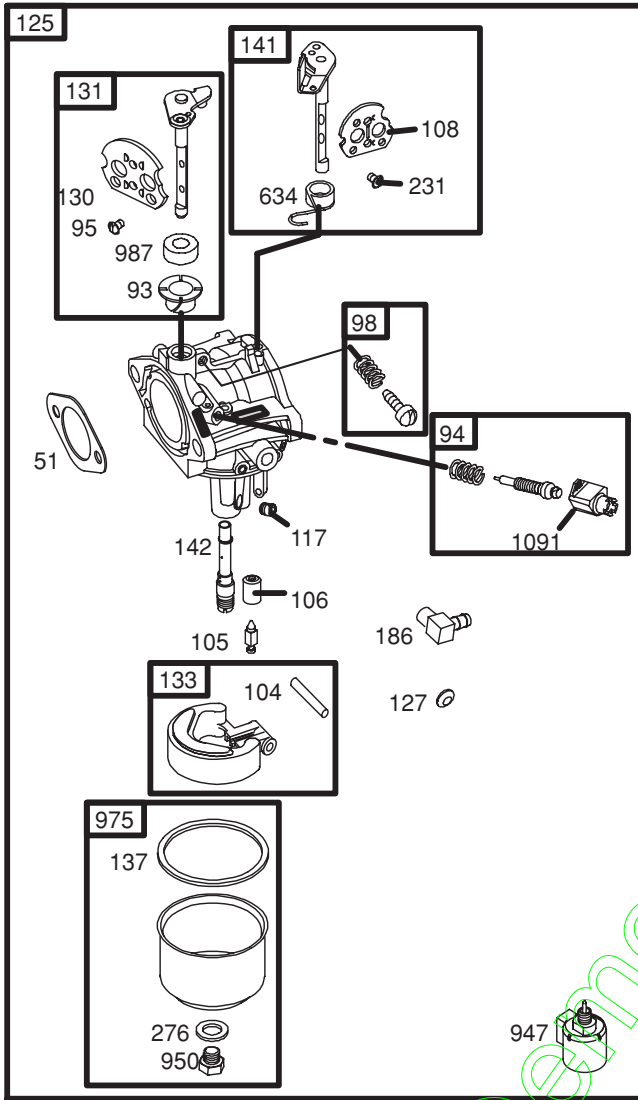

121 CARBURETOR OVERHAUL KIT					
51	104	127	231	987	
93	105	137	276	1266	
95	106	142	634	617	1266A
	117				

977 CARBURETOR GASKET SET		
51	137	276

REPAIR PARTS

TRACTOR- -MODEL NO. 917. 277150

BRIGGS & STRATTON ENGINE - - MODEL NUMBER 282H07, TYPE NUMBER 0239-E1

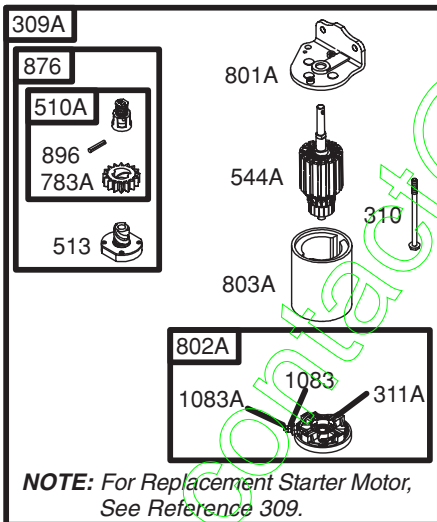
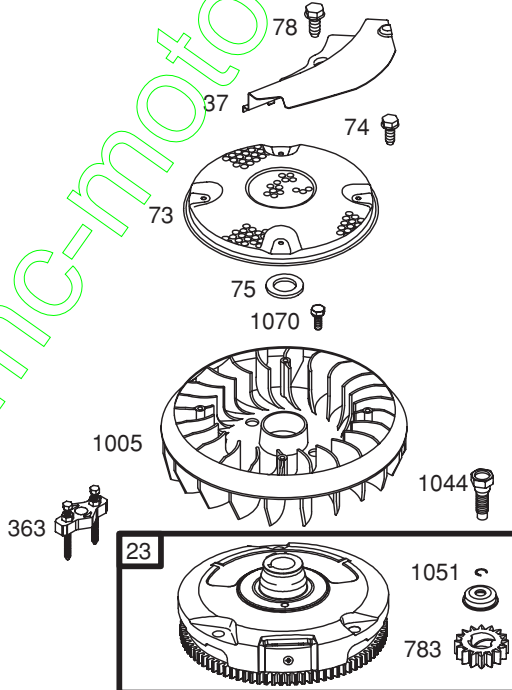
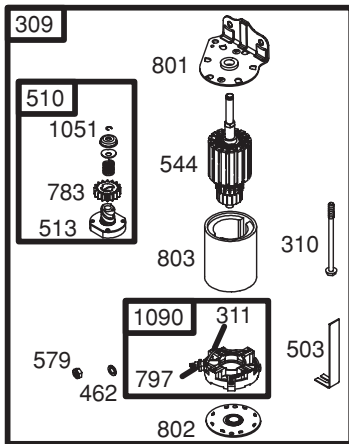
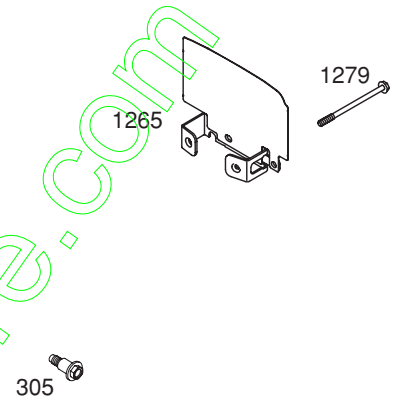
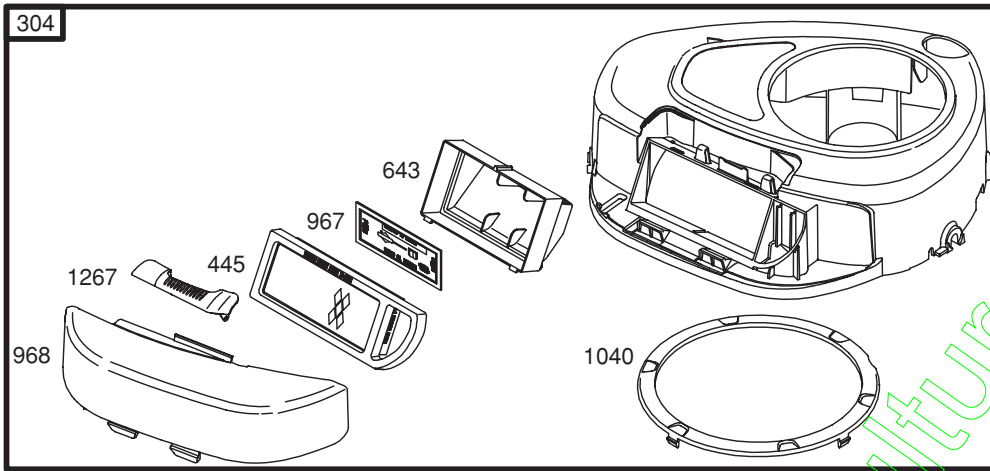

REPAIR PARTS

TRACTOR- -MODEL NO. 917. 277150

BRIGGS & STRATTON ENGINE - - MODEL NUMBER 282H07, TYPE NUMBER 0239-E1

KEY NO.	PART NO.	DESCRIPTION	KEY NO.	PART NO.	DESCRIPTION
1	697132	Cylinder Assembly	108	690464	Valve-Choke (Manual Choke)
2	399265	Kit-Bushing/Seal (Magneto Side)	108A	692344	Valve-Choke (Choke A Matic)
3	391086 •	Seal-Oil (Magneto Side)	117	694352 Ø	Jet-Main (Standard)
4	697106	Sump-Engine	118	697228	Jet-Main (High Altitude)
5	698148	Head-Cylinder	121	697241	Kit-Carburetor Overhaul
7	273280 •+	Gasket-Cylinder Head	125	697190	Carburetor
9	697109 •	Gasket-Breather	127	695005	Plug-Welch
10	697157	Screw (Breather Assembly)	130	691750	Valve-Throttle
11	697113	Tube-Breather	131	494379	Kit-Throttle Shaft
12	697110 •	Gasket-Crankcase	133	494381	Float-Carburetor
13	690360	Screw (Cylinder Head)	137	281165 Ø‡	Gasket-Float Bowl
15	690946	Plug-Oil Drain	141	495097	Kit-Choke Shaft (Manual Choke)
16	697127	Crankshaft	141A	495931	Kit-Choke Shaft (Choke A Matic)
20	690947 •	Seal-Oil (PTO Side)	142	697140 Ø	Nozzle-Carburetor
22	692125	Screw (Crankcase Cover/Sump)	146	691639	Key-Timing
23	693557	Flywheel	186	698174	Connector-Hose
24	222698	Key-Flywheel	187	697098	Line-Fuel
25	697114	Piston Assembly (Standard)	188	691693	Screw (Control Bracket)
	697116	Piston Assembly (.010" Oversize)	192	691986	Adjuster-Rocker Arm
	697117	Piston Assembly (.020" Oversize)	202	691841	Link-Mechanical Governor
	697118	Piston Assembly (.030" Oversize)	209	692208	Spring-Governor
26	697115	Ring Set (Standard)	216	691840	Link-Choke
	697119	Ring Set (.010" Oversize)	222	694042	Bracket-Control
	697120	Ring Set (.020" Oversize)	227	691374	Lever-Governor Control
	697121	Ring Set (.030" Oversize)	231	691636	Screw (Choke Valve)
27	698469	Lock-Piston Pin	232	691842	Spring-Governor
28	697099	Pin-Piston	238	691843	Cap-Valve
29	697126	Rod-Connecting (Standard)	240	394358	Filter-Fuel
32	692852	Screw (Connecting Rod)	265	691024	Clamp-Casing
33	495856	Valve-Exhaust	267	695134	Screw (Casing Clamp)
34	495857	Valve-Intake	276	692255 Ø‡	Washer-Sealing
35	691279	Spring-Valve (Intake)	304	698402	Housing-Blower
36	691279	Spring-Valve (Exhaust)	305	697102	Screw (Blower Housing)
37	697352	Guard-Flywheel	305A	697103	Screw (Blower Housing)
40	691752	Retainer-Valve	306	697107	Shield-Cylinder
43	691968	Slinger-Governor/Oil	307	691003	Screw (Cylinder Shield)
45	690564	Tappet-Valve	309	693551	Motor-Starter
46	697687	Camshaft	309A	--- -- --	Motor-Starter (For Replacement Starter Motor, See Reference 309)
48	697761	Short Block (31C707-0230-E2 Replacement Engine-art not available)	310	690323	Bolt (Starter Motor)
50	690193	Manifold-Intake	311	497608	Brush Set
51	692137 •Ø‡+	Gasket-Intake	311A	395538	Brush Set
53	690227	Stud (Carburetor)	333	492341	Armature-Magneto
54	691148	Screw (Intake Manifold)	334	691061	Screw (Magneto Armature)
73	697384	Screen-Rotating	337	691043	Plug-Spark
74	697987	Screw (Rotating Screen)	358	697151	Gasket Set-Engine
75	690582	Washer (Flywheel)	363	19203	Flywheel Puller
78	691003	Screw (Flywheel Guard)	383	89838	Wrench-Spark Plug
93	690602 Ø	Bushing-Throttle Shaft			RPM Settings: Low Speed: 1900-2100 High Speed: 3000-3200
94	498030	Kit-Idle Mixture			
95	691636	Screw (Throttle Valve)			
98	495800	Kit-Idle Speed			
104	690525 Ø	Pin-Float Hinge			• Included in Engine Gasket Set, Key. No. 358
105	231855 Ø	Valve-Float Needle			Ø Included in Carburetor Overhaul Kit, Key. No. 121
106	690577 Ø	Seat-Inlet			‡ Included in Carburetor Gasket Set, Key. No. 977
					+ Included in Valve Gasket Set, Key. No. 1095

NOTE: All component dimensions given in U.S. inches
1 inch = 25.4 mm

REPAIR PARTS

TRACTOR- -MODEL NO. 917. 277150

BRIGGS & STRATTON ENGINE - - MODEL NUMBER 282H07, TYPE NUMBER 0239-E1

KEY NO.	PART NO.	DESCRIPTION	KEY NO.	PART NO.	DESCRIPTION
404	691691	Washer (Governor Crank)	868	690968 •+	Seal-Valve
431	697122	Elbow-Intake	876	495877	Kit-Pinion Spring
445	698083	Filter-Air Cleaner Cartridge	877	393456	Wire-Connector/Alternator
462	691261	Washer (Starter Cable)	896	691641	Pin-Drive Retainer
474	696459	Alternator	914	690960	Screw (Rocker Cover)
503	691532	Strap-Starter	947	694393	Solenoid-Fuel
505	691251	Nut (Governor Control Lever)	950	691657	Screw (Float Bowl)
510	693699	Drive-Starter	967	697015	Filter-Pre Cleaner
510A	497606	Drive-Starter	968	698403	Cover-Air Cleaner
513	692024	Clutch-Drive	975	495933	Bowl-Float
523	697086	Dipstick	977	690192	Gasket Set-Carburetor
524	691032 •	Seal-Dipstick Tube	987	691326 Ø	Seal-Throttle Shaft
525	697184	Tube-Dipstick	1005	697853	Fan-Flywheel
544	692034	Starter-Armature	1019	697143	Kit-Label
544A	390837	Starter-Armature	1022	272475 •+	Gasket-Rocker Cover
552	697144	Bushing-Governor Crank	1023	692492	Cover-Rocker Arm
559	697561	Screw (Remote Choke)	1026	692003	Rod-Push (Intake)
559A	693675	Screw (Remote Choke)	-- --	692011	Rod-Push (Exhaust)
562	691119	Bolt (Governor Control Lever)	1029	691751	Arm-Rocker
579	691029	Nut (Starter Cable)	1034	690822	Guide-Push Rod
584	697112	Cover-Breather Passage	1036	695700	Label-Emission
601	95162	Clamp-Hose	1040	698368	Plate-Trim
614	691620	Pin-Cotter	1044	691658	Screw (Flywheel)
616	692012	Crank-Governor	1051	691265	Ring-Retaining
617	692138 Ø •	Seal-O Ring (Intake Manifold)	1058	275038	Owner's Manual
634	690801 Ø	Spring/Seal Assembly (Manual Choke)	1059	698516	Kit-Screw/Washer
634A	690802 Ø	Spring/Seal Assembly (Choke A Matic)	1070	690372	Screw (Flywheel Fan)
635	691909	Boot-Spark Plug	1083	691626	Nut (Starter Terminal)
643	698401	Retainer-Air Filter	1083A	690958	Nut (Starter Terminal)
654	690958	Nut (Carburetor)	1090	691293	Retainer-Brush
691	692407 •	Seal-Governor Shaft	1091	691333	Cap-Limiter
697	690372	Screw (Drive Cap)	1095	691581	Gasket Set-Valve
718	690959	Pin-Locating	1119	691183	Screw (Alternator)
729	691224	Clip-Wire	1263	697124	Reed-Breather
741	697128	Gear-Timing	1264	697104	Screw (Breather Reed)
757	697607	Link-Counterweight	1265	697125	Support-Blower Housing
758	697134	Counterweight	1266	691917 •Ø	Seal-O Ring (Intake Elbow)
759	697392	Pin-Counterweight	1266A	697123 Ø	Seal-O Ring (Intake Elbow)
783	693713	Gear-Pinion	1267	697575	Latch-Blower Housing
783A	693059	Gear-Pinion	1270	697156	Plug-AVS Counterweight
789	698329	Harness-Wiring	1279	690960	Screw (Blower Housing Support)
797	693167	Nut (Brush Retainer)	RPM Settings:		Low Speed: 1900-2100
801	691283	Cap-Drive			High Speed: 3000-3200
801A	394856	Cap-Drive	• Included in Engine Gasket Set, Key. No. 358		
802	691286	Cap-End	Ø Included in Carburetor Overhaul Kit, Key. No. 121		
802A	395537	Cap-End	‡ Included in Carburetor Gasket Set, Key. No. 977		
803	693757	Housing-Starter	+ Included in Valve Gasket Set, Key. No. 1095		
803A	398159	Housing-Starter			
830	691095	Stud (Rocker Arm)	NOTE: All component dimensions given in U.S. inches		
842	691031 •	Seal-O Ring (Dipstick Tube)	1 inch = 25.4 mm		
847	697611	Dipstick/Tube Assembly			
851	692424	Terminal-Spark Plug			

LIMITED WARRANTY ON CRAFTSMAN RIDING EQUIPMENT

For one (1) year from the date of purchase, if this Craftsman Riding Equipment is maintained, lubricated and tuned up according to the instructions in the owner's manual, Sears will repair or replace free of charge any parts that are found to be defective in material or workmanship according to the guidelines of coverage listed below. Sears will also provide free labor for these applicable warranted parts for the full year. During the first 30 days of purchase, there will be no charges to service the product at your home for issues covered by this warranty. (See exclusions below). For your convenience, IN HOME warranty service will still be available after the first 30 days of purchase, but a trip charge will apply. This charge will be waived if the Craftsman product is dropped off at an authorized Sears location. For the nearest authorized Sears location, please call 1-800-4-MY-HOME®. This warranty applies only while this product is within the United States.

This Warranty does not cover:

- Expendable items which become worn during normal use, including but not limited to blades, spark plugs, air cleaners, belts, and oil filters.
- Standard Maintenance Servicing, oil changes, or tune-ups
- Tire replacement or repair caused by punctures from outside objects, such as nails, thorns, stumps, or glass.
- Repairs necessary because of operator abuse, including but not limited to, damage caused by towing objects beyond the capability of the riding equipment, impacting objects that bend the frame or crankshaft, or over-speeding the engine.
- Repairs necessary because of operator negligence, including but not limited to, electrical and mechanical damage caused by improper storage, failure to use the proper grade and amount of engine oil, failure to keep the deck clear of flammable debris, or failure to maintain the equipment according to the instructions contained in the owner's manual.
- Engine (fuel system) cleaning or repairs caused by fuel determined to be contaminated or oxidized (stale). In general, fuel should be used within 30 days of its purchase date.
- Normal deterioration and wear of the exterior finishes, or product label replacement.
- Riding equipment used for commercial or rental purposes.

LIMITED WARRANTY ON BATTERY

For ninety (90) days from date of purchase, if any battery included with this riding equipment proves defective in material or workmanship and our testing determines the battery will not hold a charge, Sears will replace the battery at no charge. During the first 30 days of purchase, there will be no charges to replace the battery at your HOME. After the first 30 days, for your convenience, IN-HOME warranty service will still be available but a trip charge will apply. This charge will be waived if the Craftsman product is dropped off at an authorized Sears location. For the nearest authorized Sears location, please call 1-800-4-MY-HOME®.

This battery warranty applies only while this product is within the United States.

This warranty gives you specific legal rights, and you may also have other rights, which vary, from state to state.

Sears, Roebuck and Co., Dept. 817WA, Hoffman Estates, IL 60179

