

**REPAIR PARTS MANUAL**  
**MODEL NO. 277153**  
**Lawn Tractor**

---

**CRAFTSMAN®**

# HOW TO USE THIS MANUAL

This manual is designed to provide the customer with a means to identify the parts on his/her tractor when ordering repair parts. The illustrations may or may not represent the actual assemblies; therefore, it is not recommended to use this manual as a guide to assemble or disassemble the tractor. Some hardware and parts are drawn larger in order to more readily identify them.

Each tractor has its own model number.

The model number for your tractor can be found on the fender under the seat.

When ordering parts, always give the following information:

- Product - "Tractor"
- Model Number - "277153"
- Part Number
- Part Description

## TABLE OF CONTENTS

SCHEMATIC .....	3
ELECTRICAL.....	4-5
CHASSIS.....	6-7
DRIVE.....	8-9
STEERING .....	10-11
SEAT .....	12
DECALS.....	13
ENGINE.....	14
MOWER LIFT .....	15
MOWER DECK .....	16-17
TRANSAXLE.....	18-19
ENGINE BREAKDOWN.....	20-25
WARRANTY.....	27

# TRACTOR- -MODEL NO. 917.277153

## SCHEMATIC

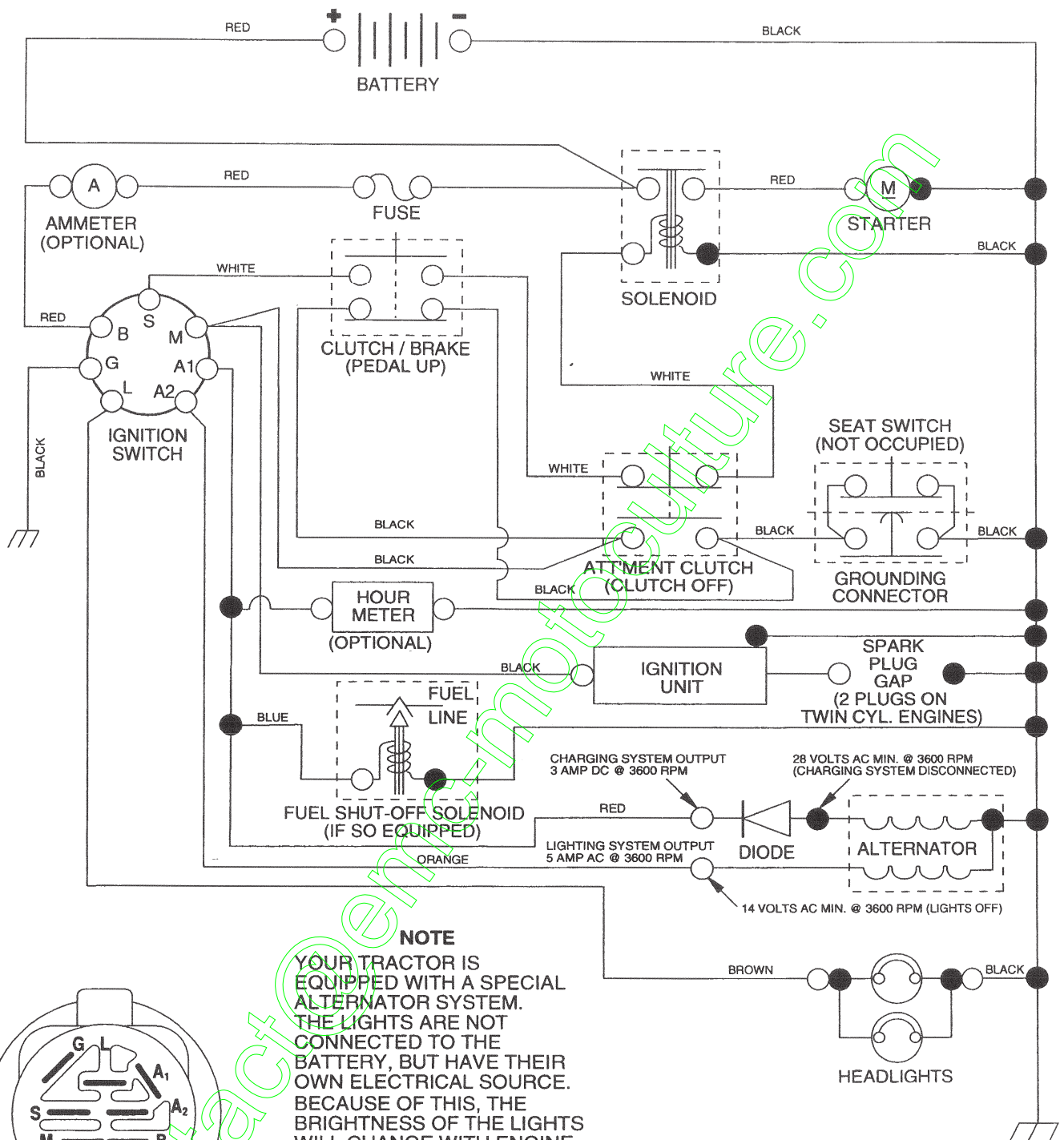

### NOTE

YOUR TRACTOR IS EQUIPPED WITH A SPECIAL ALTERNATOR SYSTEM. THE LIGHTS ARE NOT CONNECTED TO THE BATTERY, BUT HAVE THEIR OWN ELECTRICAL SOURCE. BECAUSE OF THIS, THE BRIGHTNESS OF THE LIGHTS WILL CHANGE WITH ENGINE SPEED. AT IDLE THE LIGHTS WILL DIM. AS THE ENGINE IS SPEEDED UP, THE LIGHTS WILL BECOME THEIR BRIGHTEST.

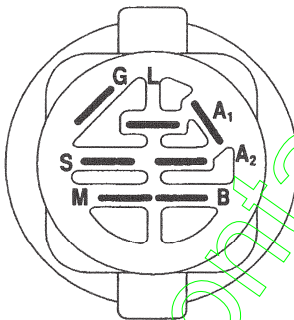

IGNITION SWITCH

POSITION	CIRCUIT	"MAKE"
OFF	M+G+A1	NONE
RUN/LIGHT	B+A1	A2+L
RUN	B+A1	NONE
START	B + S + A1	NONE

### WIRING INSULATED CLIPS

NOTE: IF WIRING INSULATED CLIPS WERE REMOVED FOR SERVICING OF UNIT, THEY SHOULD BE REPLACED TO PROPERLY SECURE YOUR WIRING.

02363

NON-REMOVABLE CONNECTIONS

REMOVABLE CONNECTIONS

# REPAIR PARTS

TRACTOR- -MODEL NO. 917.277153

## ELECTRICAL

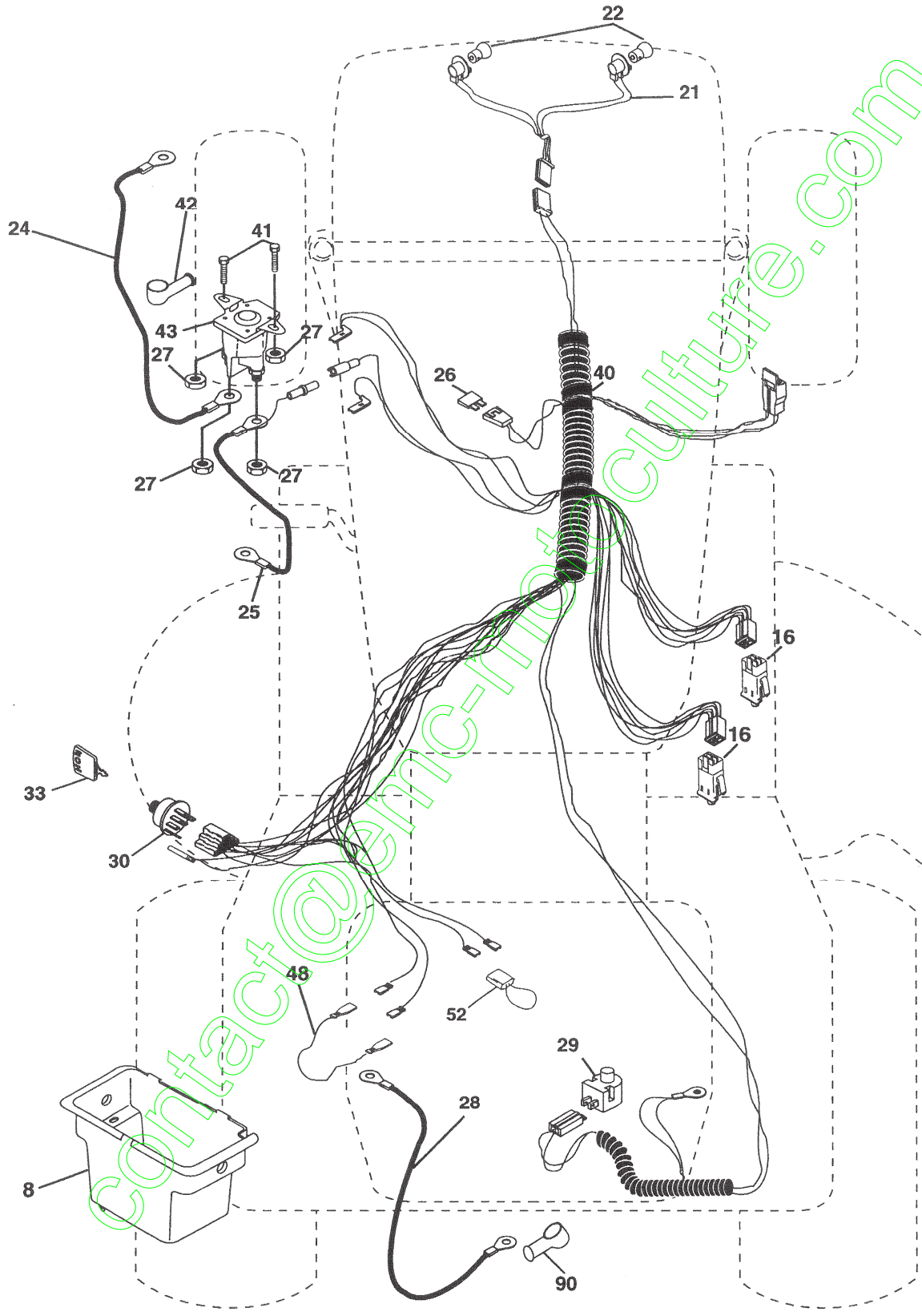

# REPAIR PARTS

TRACTOR- -MODEL NO. 917.277153

## ELECTRICAL

KEY NO.	PART NO.	DESCRIPTION
1	163465	Battery
2	74760412	Bolt Hex Hd 1/4-20 unc x 3/4
8	176689	Box Battery
16	176138	Switch Interlock
21	183759	Harness Asm Light W/4152j
22	4152J	Bulb Light #1156
24	4799J	Cable Battery 6 Ga. 11"red
25	146147	Cable Battery
26	175158	Fuse 20 AMP
27	73510400	Nut Keps Hex 1/4-20 unc
28	4207J	Cable Ground 6 Ga. 12"black
29	121305X	Switch Plunger N6 Gray
30	175566	Switch Ign
33	140403	Key Ign
40	179720	Harness Ign
41	71110408	Bolt Blk Fin Hex 1/4-20
42	131563	Cover Terminal Red
43	178861	Solenoid
48	140844	Adapter Ammeter
52	141940	Protection Wire Loop
90	180449	Cover Terminal Battery

**NOTE:** All component dimensions given in U.S. inches.  
1 inch = 25.4 mm.

# REPAIR PARTS

TRACTOR- -MODEL NO. 917.277153

## CHASSIS AND ENCLOSURES

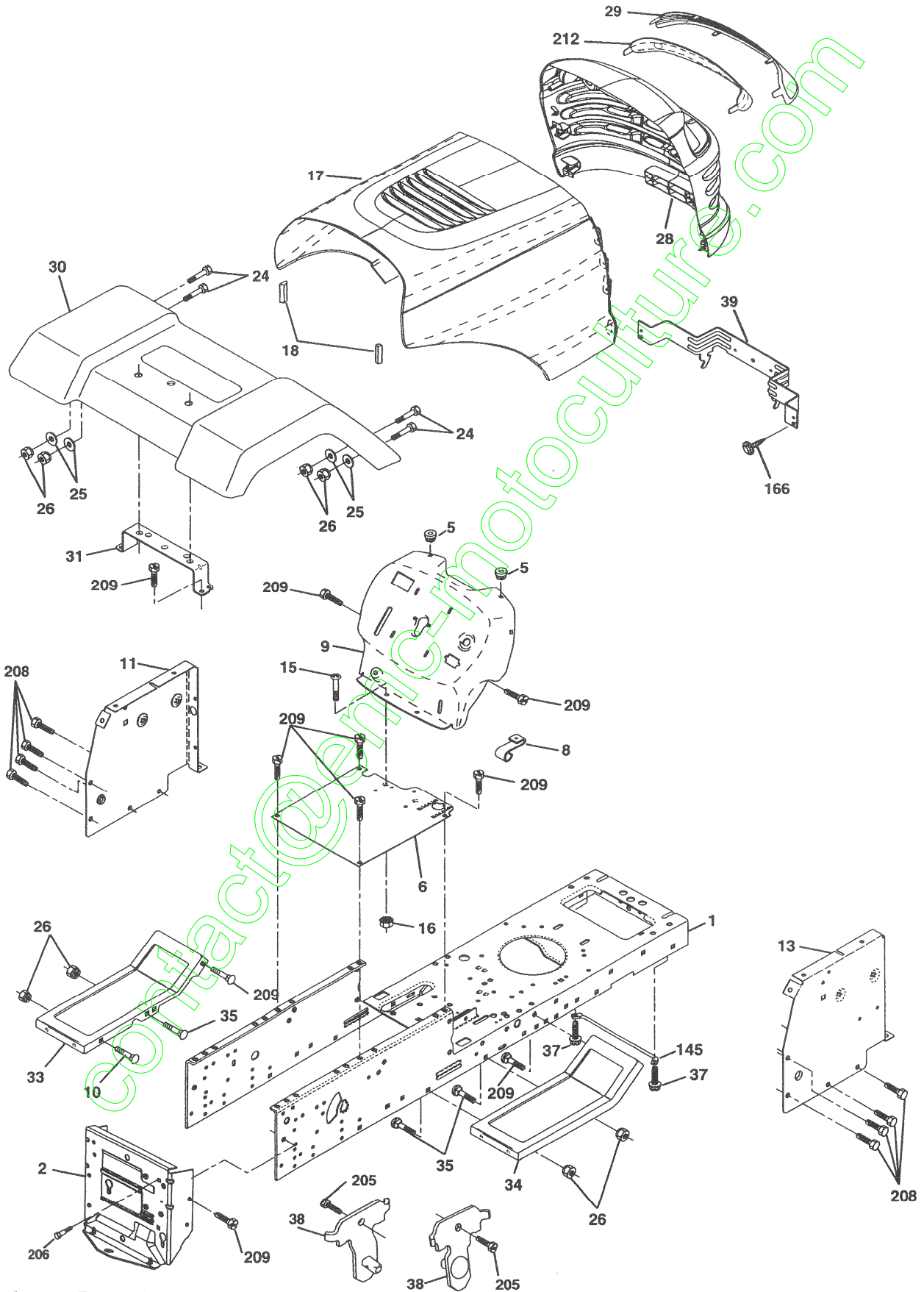

# REPAIR PARTS

TRACTOR- -MODEL NO. 917.277153

## CHASSIS AND ENCLOSURES

KEY NO.	PART NO.	DESCRIPTION
1	174620	Chassis
2	176554	Drawbar, Stretch
5	155272	Bumper, Hood/Dash
6	174643X013	Saddle Silkscreen
8	155138	Clip Retainer Slide-On
9	187834X011	Dash
10	72140608	Bolt, Carriage 3/8-16 x 1
11	174996	Panel Dash LH
13	172105X010	Panel Silkscr Dash RH
15	74180512	Screw Mach TRHD 5/16-18 unc x 3/4
16	73510500	Nut Keps-5/16-18 unc
17	185682X558	Hood
18	184921	Bumper Hood
24	74780616	Bolt Fin Hex 3/8-16 unc x 1 Gr. 5
25	19131312	Washer 13/32 x 13/16 x 12 Ga.
26	73800600	Nut Lock Hex w/Ins 3/8-16 unc
28	190380	Grille/Lens Asm. (Includes Key nos. 29 and 212)
29	174332X599	Lens Grille Basic Bar
30	169465X558	Fender
31	136619	Bracket Fender Repl 109873X
33	179716X558	Footrest Pnt LH
34	179717X558	Footrest Pnt RH
35	72110606	Bolt Rdhd Sht Sqnk 3/8-16 x 3/4
37	17490508	Screw Thdrol 5/16-18 x 1/2 TYT
38	175710	Bracket Asm. Pivot Mower
39	174714	Bracket Pivot
145	156524	Rod Pivot Chassis/Hood
166	171875	Screw Hwhd Hi-Lo #13-16 x 5/8
205	17490608	Screw Thdrol 3/8-16 x 1/2
206	170165	Bolt Shoulder 5/16-18
208	17670608	Screw Thdrol 3/8-16 x 1/2
209	17000612	Screw Hex Wsh Thdrol 3/8-16
212	175143	Insert Lens Reflect
---	5479J	Plug Button Blk 359 Dia Choke

**NOTE:** All component dimensions given in U.S. inches.  
1 inch = 25.4 mm.

# REPAIR PARTS

TRACTOR- -MODEL NO. 917.277153

## DRIVE

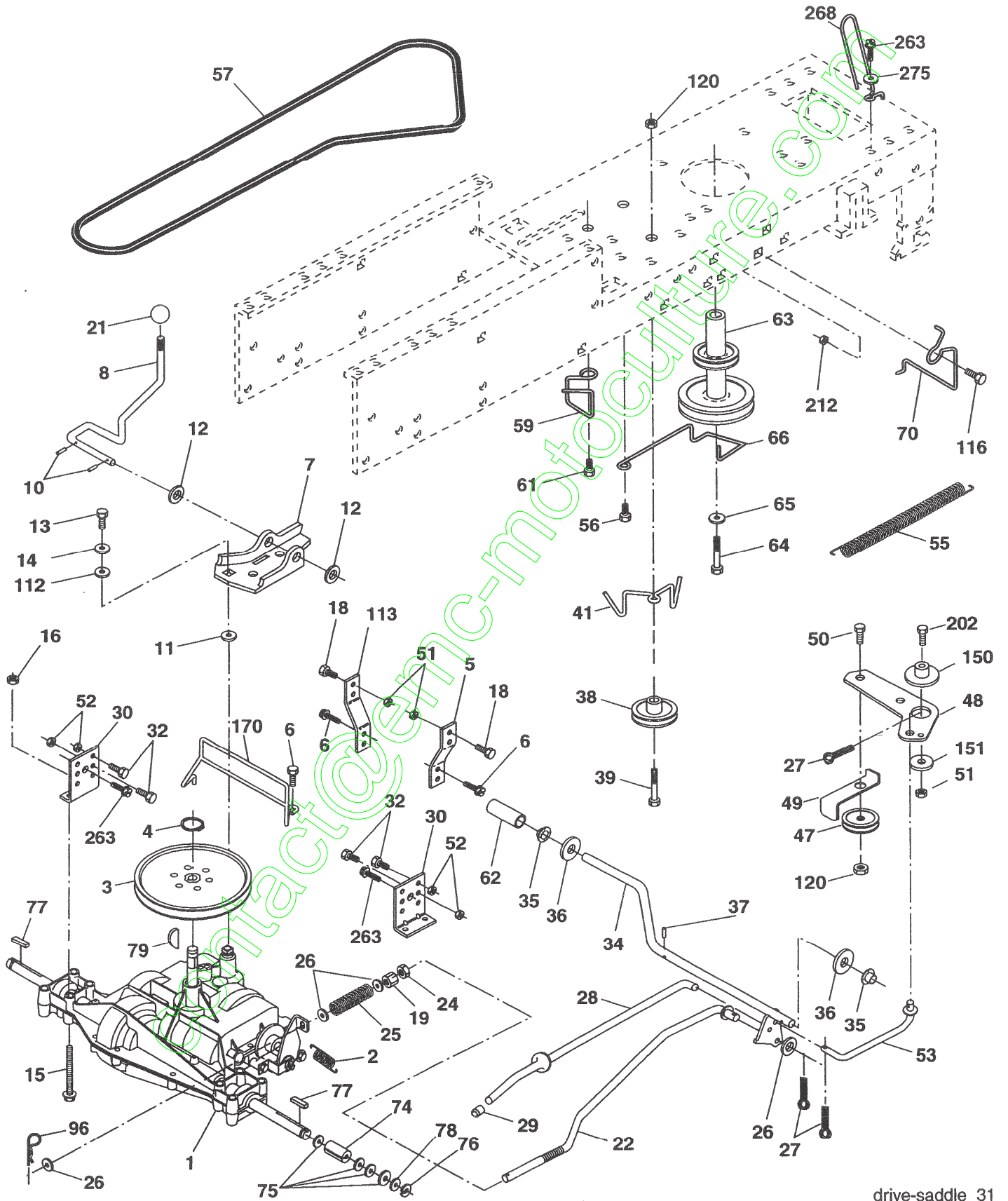

drive-saddle\_31



# REPAIR PARTS

## TRACTOR- -MODEL NO. 917.277153

### DRIVE

KEY NO.	PART NO.	DESCRIPTION	KEY NO.	PART NO.	DESCRIPTION
1	-----	Transaxle Peerless Model 205-544C (See Breakdown)	50	72110612	Bolt Carr Sh 3/8-16 x 1-1/2 Gr. 5
2	146682	Spring Return Brake	51	73680600	Nut Crownlock 3/8-16 unc
3	123666X	Pulley Transaxle 18" tires	52	73680500	Nut Crownlock 5/16-18 unc
4	12000028	Ring Retainer # 5100-62	53	105710X	Link Clutch 7 66
5	121520X	Strap Torque 30 Degrees RH	55	105709X	Spring Return Clutch 6 75
6	17000512	Screw 5/16-18 x 3/4	56	17060620	Screw 3/8-16 x 1-1/4
7	162240	Plate Rod Shift T/a	57	130801	V-Belt Ground Drive 95
8	131679	Rod Shifter Blk	59	169691	Keeper Belt Chassis Span Ctr
10	76020416	Pin Cotter 1/8 x 1 Cad	61	17120614	Screw 3/8-16 x .875
11	105701X	Washer Plate Shf 388 Sq Hole	62	8883R	Cover Pedal Blk Round
12	19151216	Washer 15/32 x 3/4 x 16 Ga.	63	180219	Engine Pulley
13	74550412	Bolt 1/4-28 unf Gr. 8 w/Patch	64	173937	Bolt Hex 7/16-20 x 4 Gr. 5
14	10040400	Washer Lock Hvy Helical 1/4	65	10040700	Washer Lock Hvy Hlcl Spr 7/16
15	74490544	Bolt Hex Flghd 5/16-18 Gr. 5	66	154778	Keeper Belt Engine
16	73800500	Nut 5/16-18	70	180218	Guide Belt Mower Drive RH
18	74780616	Bolt Fin Hex 3/8-16 unc x 1 Gr. 5	74	137057	Spacer Axle
19	73800600	Nut lock Hex w/Ins 3/8-16 Unc	75	121749X	Washer 25/32 x 1 1/4 x 16 Ga.
21	106933X	Knob Rd 1/2-13 Plstc Thds Blk	76	12000001	E-ring #5133-75
22	130804	Rod Brake LT	77	123583X	Key Square 2 0 x 1845/ 1865
24	73350600	Nut Hex Jam 3/8-16 unc	78	121748X	Washer 25/32 x 1-5/8 x 16 Ga.
25	106888X	Spring Rod Brake 2 00 Zinc	79	2228M	Key Woodruff
26	19131316	Washer 13/32 x 13/16 x 16 Ga.	96	4497H	Retainer Spring 1"
27	76020412	Pin Cotter 1/8 x 3/4 Cad	112	19091210	Washer 9/32 x 3/4 x 10 Ga.
28	175765	Rod Brake Parking LT/YT	113	127285X	Strap Torque 90 Degrees LH
29	71673	Cap Brake Parking Black	116	72140608	Bolt Rdhd Sq Neck 3/8-16 x 1
30	174973	Bracket Transmission	120	73900600	Nut Lock Flg 3/8-16
32	74760512	Bolt Fin Hex 5/16-18 x 3/4	150	175456	Spacer Retainer Lt
34	175578	Shaft Asm Pedal Foot Nibbed	151	19133210	Washer 13/32 x 2 x 10 Ga.
35	120183X	Bearing Nylon Blk 629 Id	170	187414	Keeper, Belt Transaxle
36	19211616	Washer 21/32 x 1 x 16 Ga.	202	72110614	Bolt Carr Sh 3/8-16 x 1-3/4 Gr. 5
37	1572H	Pin Roll 3/16 x 1"	212	145212	Nut Hex Flg Lock
38	179114	Pulley Composite Flat	263	17000612	Screw 3/8-16 x 3/4
39	72110622	Bolt 3/8-16 x 2-3/4	268	182402	Guard Muffler RH
41	175556	Keeper Belt Idler	275	19131614	Washer
47	127783	Pulley Idler V Groove Plastic			
48	154407	Bellcrank Clutch Grnd Drv STL			
49	123205X	Retainer Belt Style Spring			

**NOTE:** All component dimensions given in U.S. inches  
1 inch = 25.4 mm

contact@emc-mc.com



# REPAIR PARTS

## TRACTOR- -MODEL NO. 917.277153

### STEERING ASSEMBLY

KEY NO.	PART NO.	DESCRIPTION
1	140044X428	Wheel Steering
2	175131	Axle Asm
3	169840	Spindle Asm LH
4	169839	Spindle Asm RH
5	6266H	Bearing Race Thrust Harden
6	121748X	Washer 25/32 x 1-5/8 x 16 Ga.
7	19272016	Washer 27/32 x 1-1/4 x 16 Ga.
8	12000029	Ring Klip #t5304-75
9	3366R	Bearing Col Strg Blk
10	175121	Link Drag
11	10040600	Washer Lock Hvy Hicl Spr 3/8
12	73940800	Nut Hex Jam Toplock 1/2-20
13	136518	Spacer earing Axle Front
15	145212	Hexflange Lock
17	180641	Shaft Asm Strg
26	126847X	Bushing Link Drag Blk LR
28	19131416	Washer 13/32 x 7/8 x 16 Ga.
29	17000612	Screw 3/8-16 x 3/4
30	76020412	Pin Cotter 1/8 x 3/4 Cad
32	130465	Rod Tie Wire Form 19 75 Mech
36	155099	Bushing Strg 5/8 Id Dash
37	152927	Screw
38	140045X428	Cap Wheel Steer Ayp
39	19183812	Washer 9/16 x 2-3/8
40	73540600	Nut Crownlock 3/8-24
41	186737	Adaptor Wheel Strg
42	145054X428	Boot Dash Mtl Steering Blk
43	121749X	Washer 25/32 x 1 1/4 x 16 Ga.
44	180640	Extension Steering
46	121232X	Cap Spindle Fr Top Blk
47	183226	Fitting Grease
51	73540400	Nut 1/4-28
54	71130420	Bolt Hex 1/4-28 x 1-1/4
65	160367	Spacer Brace Axle
67	72110618	Bolt RDHD SQNK 3/8-16 x 2-1/4
68	169827	Brace Axle
71	175146	Steering Asm.
82	169835	Bracket Susp Chassis Front
88	175118	Bolt Shoulder 7/16-20
91	175553	Clip Steering
95	188967	Washer Harden .793 x 1.637 x 060

**NOTE:** All component dimensions given in U.S. inches.  
1 inch = 25.4 mm.

# REPAIR PARTS

TRACTOR- -MODEL NO. 917.277153

## SEAT ASSEMBLY

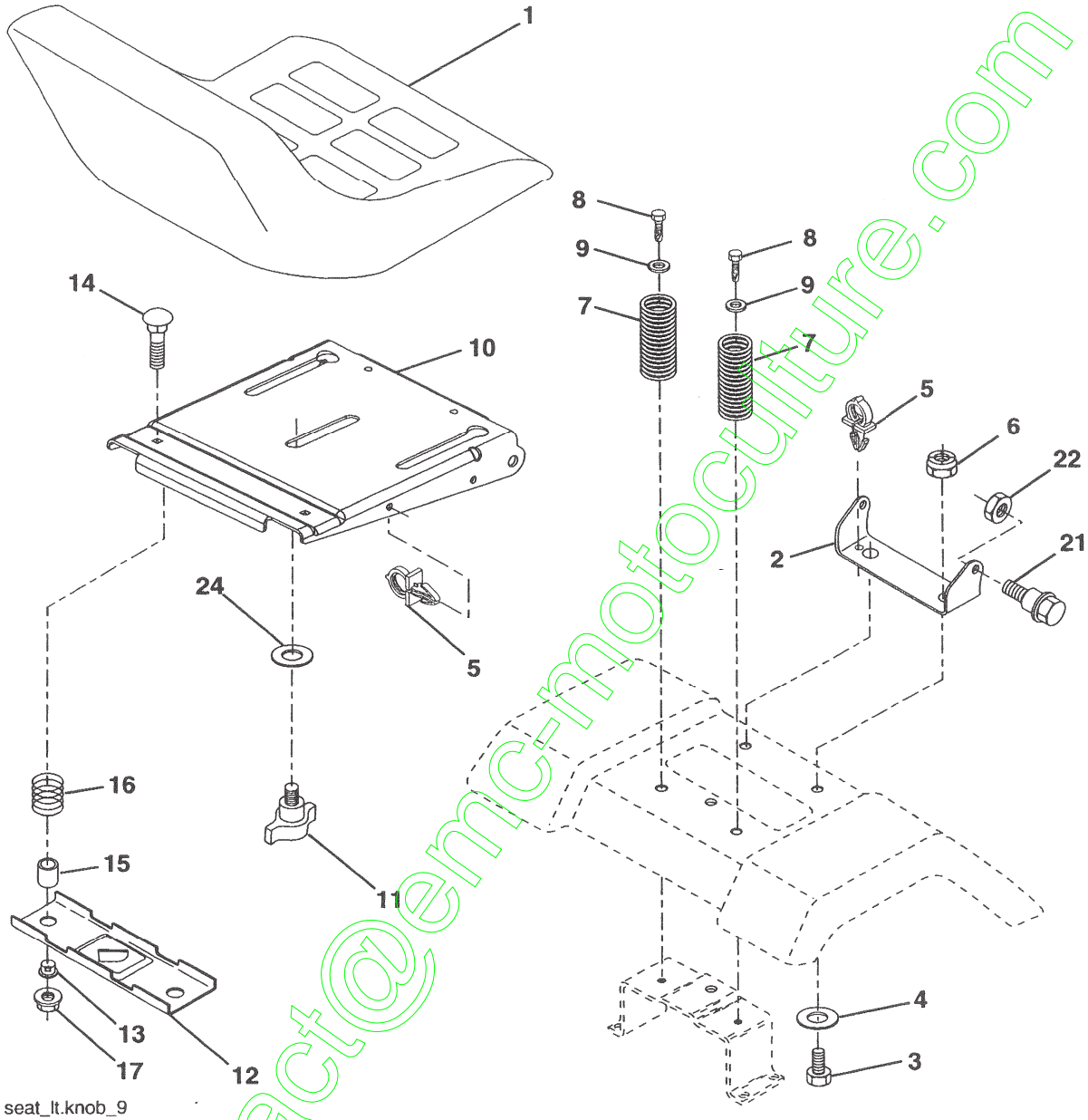

seat\_lt.knob\_9

KEY NO.	PART NO.	DESCRIPTION
1	188716	Seat
2	180166	Bracket Pivot
3	71110616	Bolt Hex 3/8 - 16 x 1
4	19131610	Washer 13/32 x 1 x10 Ga.
5	145006	Clip Push-In Hinged
6	73800600	Nut Lock Hex w/Ins 3/8 - 16
7	124181X	Spring Seat Cprsn 2 250 Blk Zi
8	17000616	Screw 3/8-16 x 1.5
9	19131614	Washer 13/32 x 1 x 14 Ga.
10	180186	Pan Pnt Seat
11	166369	Knob Seat
12	121246X	Bracket Pnt Mounting Switch

KEY NO.	PART NO.	DESCRIPTION
13	121248X	Bushing Snap Blk Nyl
14	72050412	Bolt Rdhd Sht Nk 1/4 - 20 x 1 -1/2
15	134300	Spacer Split .28 x .96
16	121250X	Spring Cprsn
17	123976X	Nut Lock 1/4 Lge Flg
21	171852	Bolt Shoulder 5/16-18 unc-2A
22	73800500	Nut Lock Hex w/Ins 5/16 - 18
24	19171912	Washer 17/32 x 1-3/16 x 12 Ga.

**NOTE:** All component dimensions given in U.S. inches.  
1 inch = 25.4 mm

# REPAIR PARTS

TRACTOR- -MODEL NO. 917.277153

## DECALS

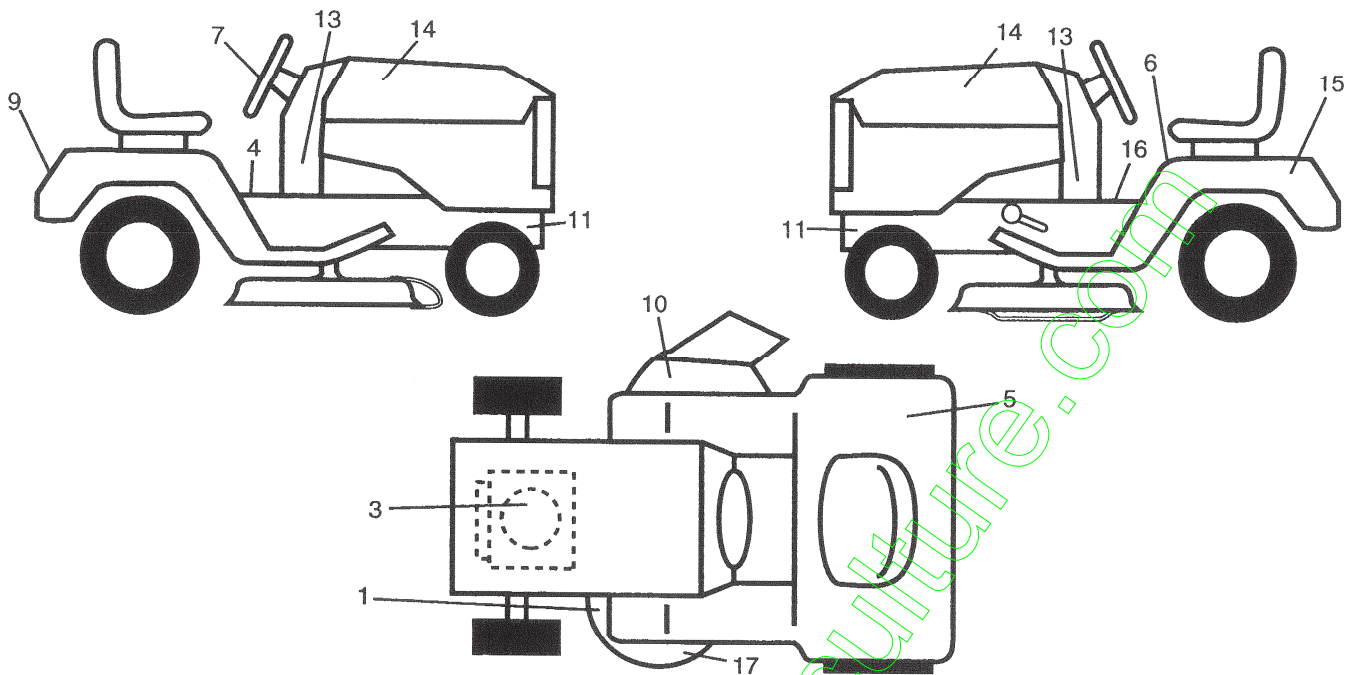

KEY NO.	PART NO.	DESCRIPTION	KEY NO.	PART NO.	DESCRIPTION
1	146046	Decal, V-Belt Sch	15	145005	Decal, Caution, Battery
3	184845	Decal, Engine HP	16	140837	Decal, Brake/Parking
5	180432	Decal, Fender DB/CE	17	136832	Decal, V-Belt Sch.
6	159737	Decal, Brake/Clutch Symbol	--	138311	Decal, Handle Lft Height Adj.
7	172275	Decal, Ins Str Wh	--	162598	Decal, Load Limit
9	163204	Decal, Fender	--	192255	Manual, Operator's (Euro)
10	182166	Decal, Cutfinger	--	192256	Manual, Operator's (Scand)
11	159736	Decal, Hot Muffler	--	192257	Manual, Parts
13	177109	Decal, Lower Dash			
14	171704	Decal, Hood LH			

## WHEELS & TIRES

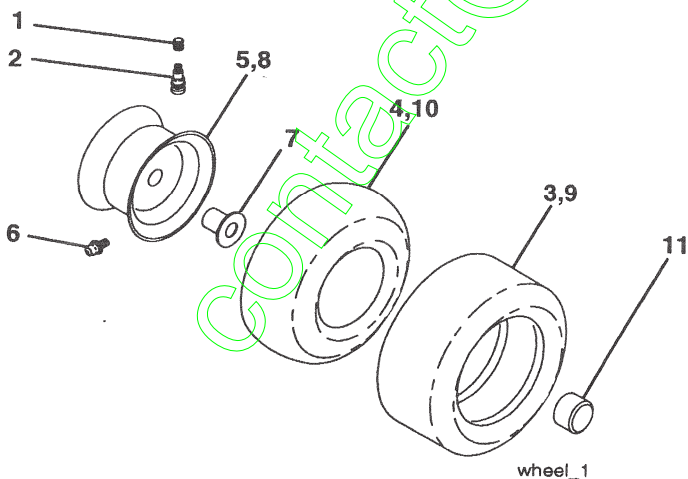

KEY NO.	PART NO.	DESCRIPTION
1	59192	Cap, Tire valve
2	65139	Stem, Valve
3	106222X	Tire, Front
4	59904	Tube, Front (Service item only)
5	106732X624	Rim assembly, 6" front
6	278H	Fitting, Grease (Front wheel only)
7	9040H	Bearing, Flange (Front wheel only)
8	106108X624	Rim assembly, 8" rear
9	124635X	Tire, Rear
10	7152J	Tube, Rear (Service item only)
11	104757X428	Cap, Hub Axle
--	144334	Sealant, Tire (10 oz. Tube)

**NOTE:** All component dimensions given in U.S. inches  
1 inch = 25.4 mm

# REPAIR PARTS

## TRACTOR- -MODEL NO. 917.277153

### ENGINE

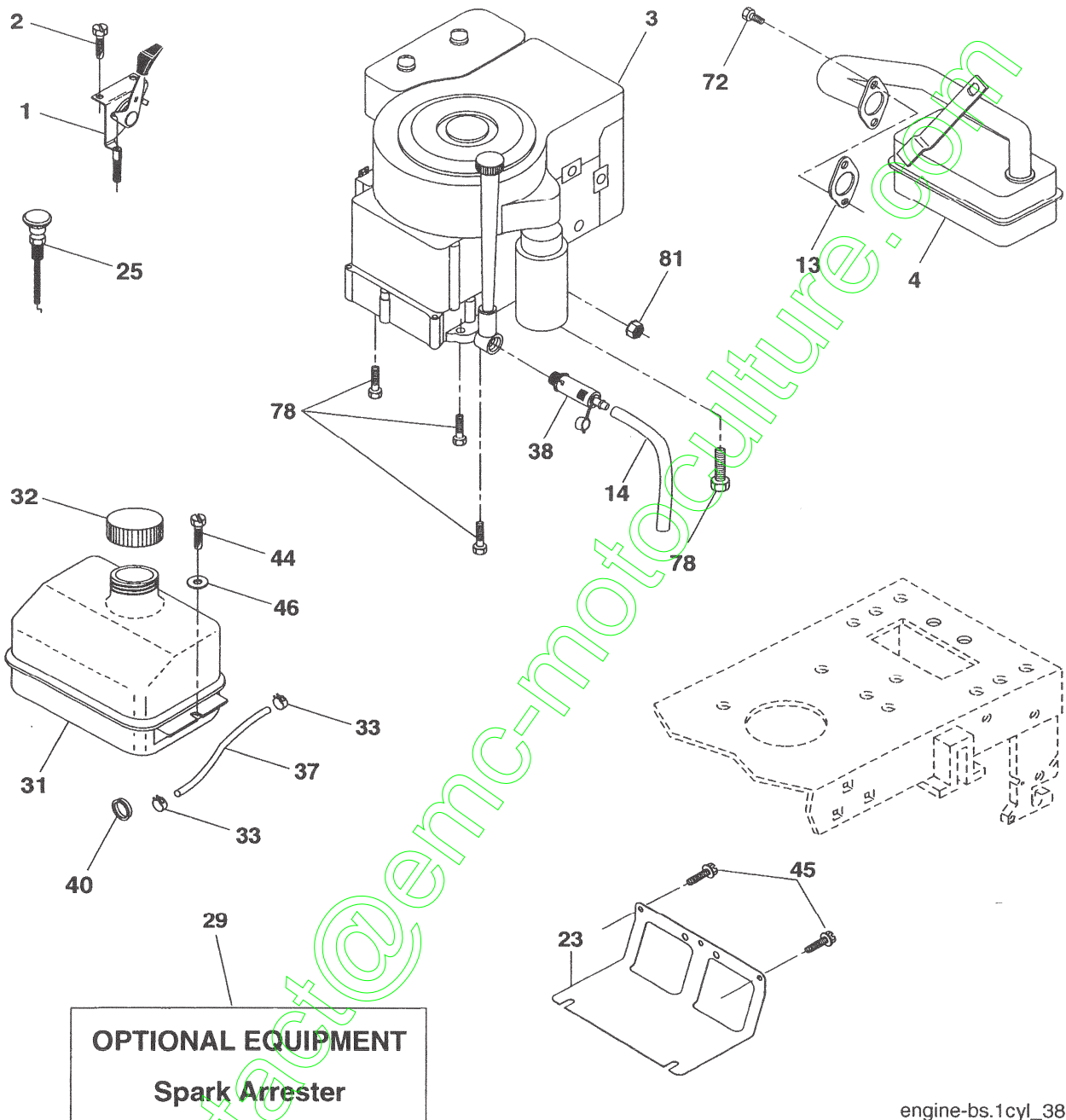

**OPTIONAL EQUIPMENT**  
**Spark Arrester**

engine-bs.1cyl\_38

KEY NO.	PART NO.	DESCRIPTION
1	170551	Control Throttle
2	17720408	Screw Hex Thd Cut 1/4-20 x 1/2
3	-----	Engine, B&S 282H07-0239-E1 (See Breakdown)
4	137352	Muffler Exhaust B&S
13	165291	Gasket Eng 1 313 Id Tin Plated
14	148456	Tube Drain Oil Easy
23	169837	Shield BRN/DBR Guard
25	187770X428	Control Choke
29	137180	Kit Spark Arrestor (Flat Scrn)
31	184900	Tank Fuel Front
32	140527	Cap Asm Fuel
33	123487X	Clamp Hose

KEY NO.	PART NO.	DESCRIPTION
37	137040	Line Fuel 20"
38	181654	Plug Drain Oil
40	124028X	Bushing Snap Nyl Blk Fuel Line
44	17670412	Screw Thdrol 1/4-20 x 3/4
45	17000612	Screw Hex Wsh Thdrol 3/8-16
46	19091416	Washer 9/32 x 7/8 x 16 Ga.
72	183906	Screw Socket Head 5/16-18 x 1
78	17060620	Screw 3/8-16 x 1-1/4
81	73510400	Nut Keps Hex 1/4-20 unc

**NOTE:** All component dimensions given in U.S. inches  
1 inch = 25.4 mm

# REPAIR PARTS

TRACTOR- -MODEL NO. 917.277153

## MOWER LIFT

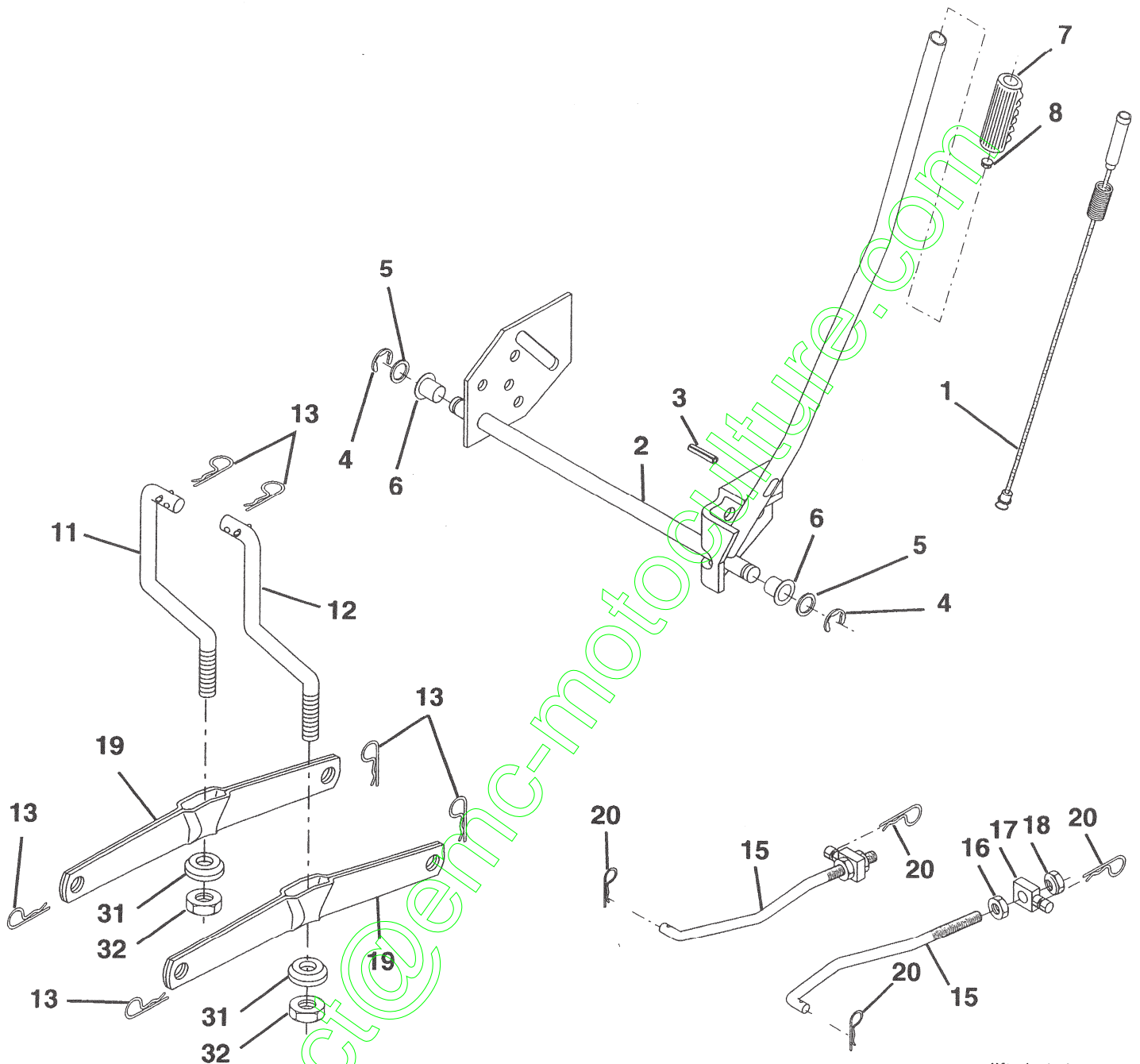

lift-rh.1piece\_3

KEY NO.	PART NO.	DESCRIPTION
1	159460	Wire Asm Inner/Sprg w/plunger
2	159471	Shaft Asm Lift RH
3	105767X	Pin Groove
4	12000002	E Ring #5133-62
5	19211621	Washer 21/32 x 1 x 21 Ga.
6	120183X	Bearing Nylon Blk 629 Id
7	125631X	Grip Handle
8	122365X	Button Plunger
11	139865	Link Lift LH Fixed Length
12	139866	Link Lift RH Fixed Length
13	4939M	Retainer Spring

KEY NO.	PART NO.	DESCRIPTION
15	173288	Link Front
16	73350800	Nut Jam Hex 1/2-13 unc
17	175689	Trunnion
18	73800800	Nut Lockw/Wsh 1/2-13 unc
19	139868	Arm Suspension Rear
20	163552	Retainer, Spring
31	169865	Bearing Pvt Lift
32	73540600	Nut Crownlock 3/8-24

**NOTE:** All component dimensions given in U.S. inches  
1 inch = 25.4 mm

# REPAIR PARTS

TRACTOR- -MODEL NO. 917.277153

MOWER

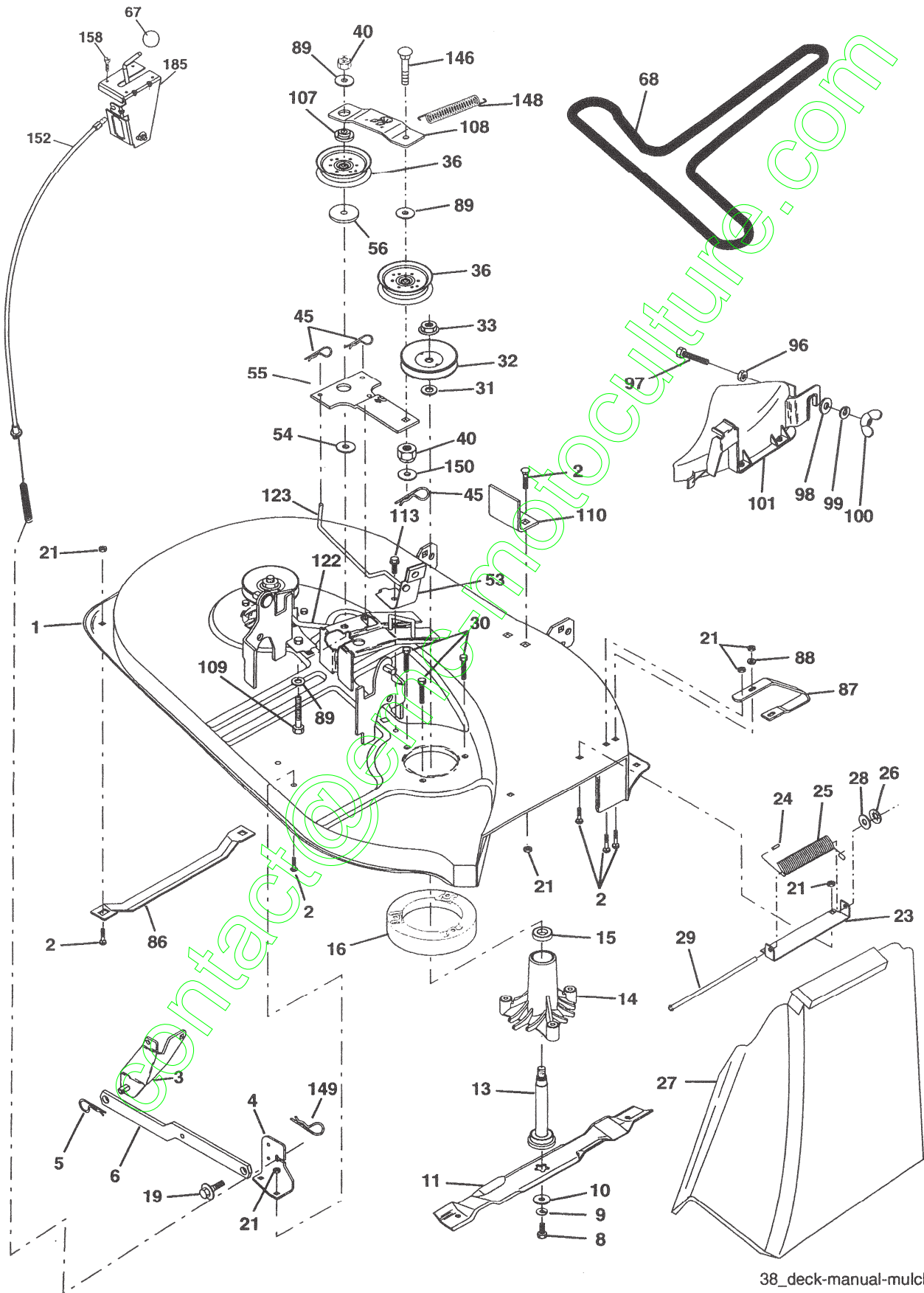



# REPAIR PARTS

## TRACTOR- -MODEL NO. 917.277153

### MOWER

KEY NO.	PART NO.	DESCRIPTION	KEY NO.	PART NO.	DESCRIPTION
1	170280	Mower Housing Assembly	68	180214	V-Belt, 42" Mower
2	72140506	Bolt Carriage 5/16-18 x 3/4	86	7631J	Runner, LH
3	138017	Bracket Asm Fr. Sway Bar	87	128772	Runner, RH
4	169970	Bracket Deck Sway Bar 38"/42"	88	19111216	Washer 11/32 x 3/4 x 16 Ga.
5	4939M	Retainer Spring	89	19131311	Washer 13/32 x 13/16 x 11 Ga.
6	178024	Bar Sway Deck	96	74930620	Bolt 3/8-16 x 1-1/4 Mulcher
8	850857	Bolt 3/8-24 x 1.25 Gr. 8	97	73930600	Nut Centerlock 3/8-16 unc
9	10030600	Washer, Lock 3/8	98	10040600	Washer
10	140296	Washer, Hardened	99	19132016	Washer
11	134148	Blade Mower	100	135651	Nut Wing
13	137645	Shaft Assembly, Mandrel, Vented (Includes Key Number 6)	101	132803	Cover Asm. Mulching
14	128774	Housing, Mandrel, Vented	107	133502	Spacer Retainer
15	110485X	Bearing, Ball, Mandrel	108	133503	Stiffener, Idler Arm
16	174493	Stripper, Vented Mower Deck	109	74760640	Bolt, Hex Hd 3/8-16 x 2-1/2
19	132827	Bolt, Shoulder	110	142587	Upstop Deck Front 38"
21	73680500	Nut	113	17060512	Screw 5/16-1/ x 3/4
23	137607	Bracket, Mower Deflector	122	131289	Rod, Brake LH
24	105304X	Cap, Sleeve	123	169971	Rod, Brake RH
25	123713X	Spring, Torsion, Deflector	146	165891	Bolt Carriage Idler
26	110452X	Nut, Push	148	169022	Spring Return Idler
27	106736X428	Shield, Deflector	149	165898	Retainer Spring Yellow
28	19111016	Washer 11/32 x 5/8 x 16 Ga.	150	19091216	Washer 9/32 x 3/4 x 16 Ga.
29	106735X	Rod, Hinge	152	172758	Clutch Cable 38"/46"
30	173984	Screw Thdrol.	158	17720408	Screw Hex Thd Cut 1/4-20 x 1/2
31	187690	Washer, Spacer	185	188234	Head Asm Cable Clutch
32	153532	Pulley, Mandrel	--	130794	Mandrel Assembly (Includes Housing, Shaft and Shaft Hardware Only - Pulley Not Included)
33	178342	Nut, Toplock	--	181209	Replacement Mower, Complete (Std. Deck - Order separately mulcher cover components key nos. 96-101)
36	131494	Pulley, Idler, Flat			
40	73680600	Nut, Crownlock 3/8-16 unc			
45	4497H	Retainer			
53	130840	Brake Assembly			
54	178515	Washer, Hardened			
55	133840	Idler Arm Assembly			
56	165723	Spacer, Retainer			
67	149846	Knob			

**NOTE:** All component dimensions given in U.S. inches  
1 inch = 25.4 mm

# REPAIR PARTS

TRACTOR- -MODEL NO. 917.277153

PEERLESS PMST TRANSAXLE - MODEL NUMBER 205-544C

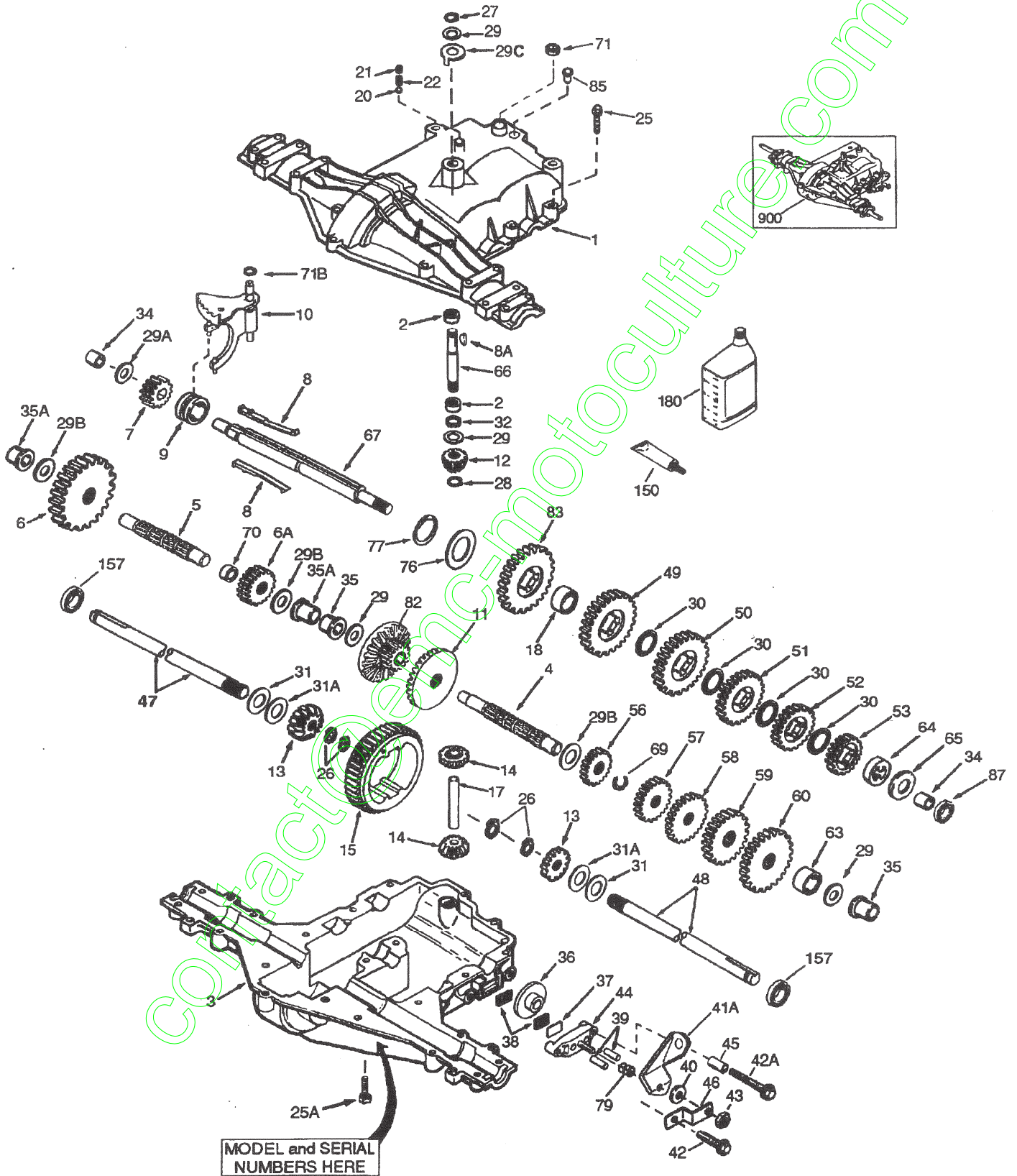

# REPAIR PARTS

## TRACTOR- -MODEL NO. 917.277153

### PEERLESS PMST TRANSAXLE - MODEL NUMBER 205-544C

KEY NO.	PART NO.	DESCRIPTION	KEY NO.	PART NO.	DESCRIPTION
1	772147	Transaxle Cover	39	786026	Dowel Pin
2	780086A	Needle Bearing 5 / 8"	40	792076A	Flat Washer .312 ID x .059W
3	770128	Transaxle Case	41A	790079	Brake Lever
4	776395	Countershaft	42	792073A	Screw 1 / 4 - 20 x 1 - 1 / 4"
5	776409	Output Shaft	42A	792085A	Screw 1 / 4 - 20 x 2 - 1 / 4"
6	778364	Spur Gear (38 teeth)	43	792075	Locknut 5 / 16 - 24
6A	778369	Spur Gear (15 teeth)	44	790025	Brake Pad Holder
7	778330	Spur Gear (11 teeth)	45	786066	Spacer .2625 x 1.0
8	792180	Shift Key	46	786086	Brake Lever Bracket
8A	792047	Woodruff Key #9	47	774690	Axle (11 - 15 / 16 " long)
9	784352	Shift Collar	48	774691	Axle (16 - 1 / 2" long)
10	784378	Shift Rod & Fork	49	778356	Spur Gear (29 teeth)
11	778334	Bevel Gear (30 teeth)	50	778354	Spur Gear (23 teeth)
12	778309	Input Bevel Pinion (13 teeth)	51	778352	Spur Gear (19 teeth)
13	778368	Bevel Gear (13 teeth) (Include. 14)	52	778350	Spur Gear (16 teeth)
14	778368	Bevel Pinion (13 teeth) (Include 13)	53	778346	Spur Gear (15 teeth)
15	778370	Ring Gear (43 teeth)	53	778346	Spur Gear (15 teeth - steel)
17	786188	Drive Pin	56	778355	Spur Gear (11 teeth)
18	786102	Spacer 1.130 x .695	57	778353	Spur Gear (17 teeth)
20	792077A	Ball 5 / 6" dia	58	778351	Spur Gear (21 teeth)
21	792078	Set Screw 3 / 8-16 x 3 / 8"	59	778349	Spur Gear (24 teeth)
22	792079	Spring .310 OD x .625 L	60	778345	Spur Gear (25 teeth)
25	792073A	Screw 1/4 - 20 x 1-1 / 4"	63	786071	Countershaft Spacer 1 - 1 / 8" x 3 / 8"
25A	792177	Screw 1 / 4 - 20 x 1 - 3 / 8"	64	786072	Brake Shaft Spacer 1 - 3 / 8" x 3 / 8"
26	792125	Retaining Ring (pkg of 2)	65	780189	Flat Washer .563 ID x .062W
27	792035	Retaining Ring	66	776422	Input shaft
28	788040	Retaining Ring	67	776396	Shifter & Brake shaft
29	780072	Thrust Washer .627 ID x .031W	69	792170	Retaining Ring
29A	780160	Thrust Washer .563 ID x .031W	70	786187	Spacer .890
29B	780051	Thrust Washer .762 ID x .031W	71	788069	Square Cut Ring
29C	780199	Anti -Rotation Washer .632	71B	788092	"O" Ring
30	780108	Cup Washer 1.127 ID x .032W	76	780090	Flat Washer 1.128 ID x .058W
31	780001	Flat Washer .750 ID x .056 (Use as Needed)	77	788078A	Inverted Retaining Ring
31A	780195	Flat Washer .750 ID x .062W	79	792144	Spring .430 OD x .5000 L
32	788083	Oil Seal 5 / 8"	82	778333	Bevel & Spur Gear (30 & 13 teeth)
34	780194	Bushing .563	83	778338	Spur Gear (27 teeth)
35	780193	Flanged Bushing 5 / 8" ID	85	792154	Oil Fill Plug
35A	780197	Flanged Bushing .751	87	788089A	Oil Seal 9 / 16"
36	790075	Brake Disk	150	788093A	Liquid Gasket RTV Silicone
37	790007	Brake Pad Plate	157	788088A	Oil Seal 3 / 4"
38	799021	Brake Pad (pkg of 2)	180	730229A	Gear Oil 80W90
			900	794711	Replacement MST-205-544C Transaxle

**NOTE:** All component dimensions given in U.S. inches  
1 inch = 25.4 mm





# REPAIR PARTS

TRACTOR- -MODEL NO. 917.277153

BRIGGS & STRATTON ENGINE - - MODEL NUMBER 282H07, TYPE NUMBER 0239-E1

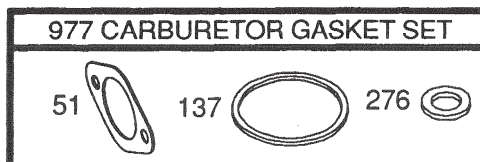
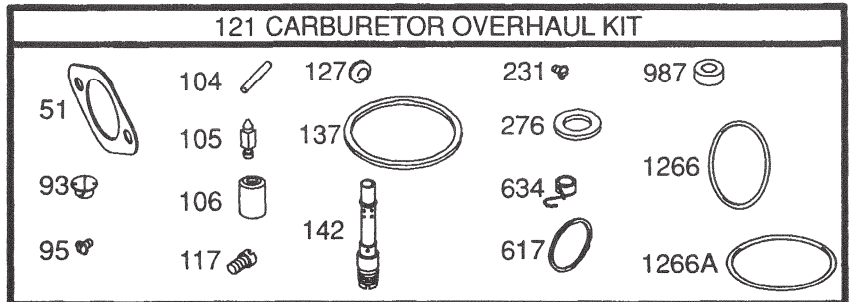
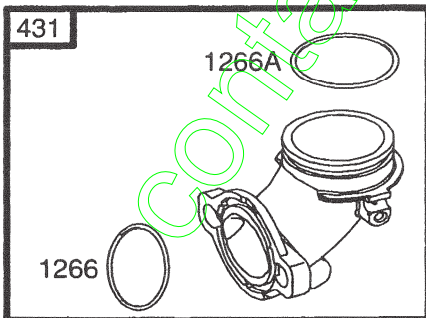
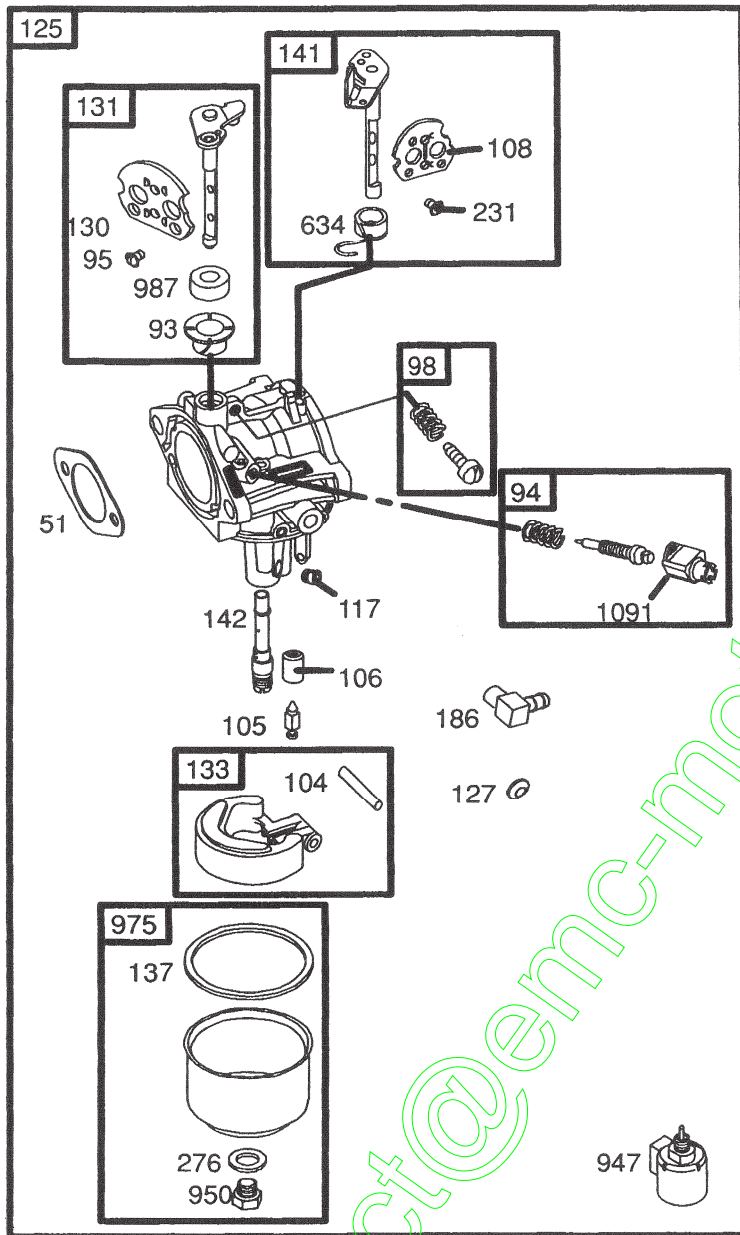

# REPAIR PARTS

TRACTOR- -MODEL NO. 917.277153

BRIGGS & STRATTON ENGINE - - MODEL NUMBER 282H07, TYPE NUMBER 0239-E1

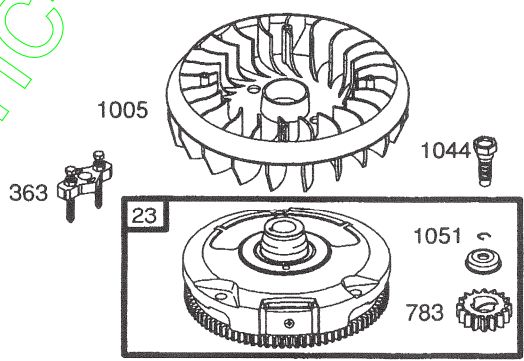
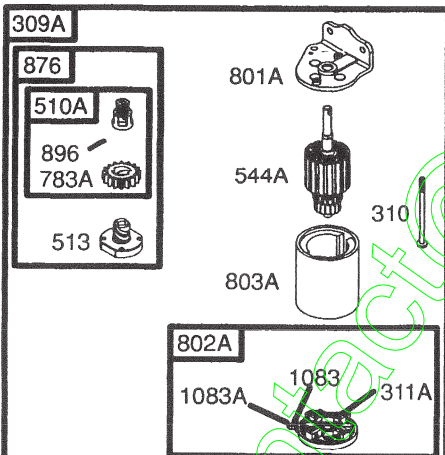
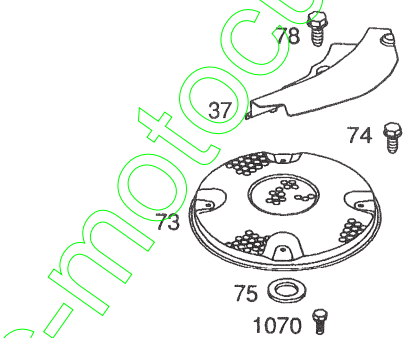
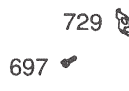
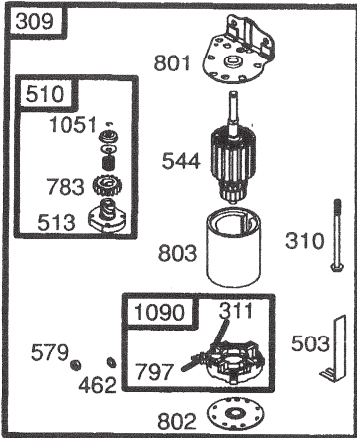
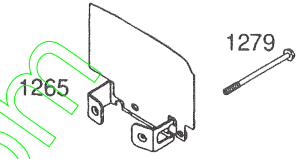
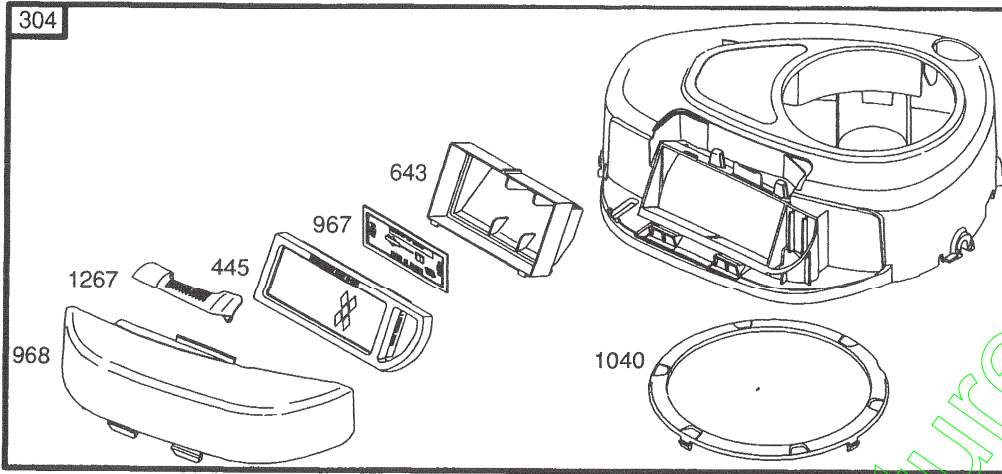

NOTE: For Replacement Starter Motor, See Reference 309.

# REPAIR PARTS

## TRACTOR- -MODEL NO. 917.277153

### BRIGGS & STRATTON ENGINE - - MODEL NUMBER 282H07, TYPE NUMBER 0239-E1

KEY NO.	PART NO.	DESCRIPTION	KEY NO.	PART NO.	DESCRIPTION
1	697132	Cylinder Assembly	108	690464	Valve-Choke (Manual Choke)
2	399265	Kit-Bushing/Seal (Magneto Side)	108A	692344	Valve-Choke (Choke A Matic)
3	391086	• Seal-Oil (Magneto Side)	117	694352	Ø Jet-Main (Standard)
4	697106	Sump-Engine	118	697228	Jet-Main (High Altitude)
5	698148	Head-Cylinder	121	697241	Kit-Carburetor Overhaul
7	273280	*± Gasket-Cylinder Head	125	697190	Carburetor
9	697109	• Gasket-Breather	127	695005	Plug-Welch
10	697157	Screw (Breather Assembly)	130	691750	Valve-Throttle
11	697113	Tube-Breather	131	494379	Kit-Throttle Shaft
12	697110	• Gasket-Crankcase	133	494381	Float-Carburetor
13	690360	Screw (Cylinder Head)	137	281165	Ø‡ Gasket-Float Bowl
15	690946	Plug-Oil Drain	141	495097	Kit-Choke Shaft (Manual Choke)
16	697127	Crankshaft	141A	495931	Kit-Choke Shaft (Choke A Matic)
20	690947	• Seal-Oil (PTO Side)	142	697140	Ø Nozzle-Carburetor
22	692125	Screw (Crankcase Cover/Sump)	146	691639	Key-Timing
23	693557	Flywheel	186	698174	Connector-Hose
24	222698	Key-Flywheel	187	697098	Line-Fuel
25	697114	Piston Assembly (Standard)	188	691693	Screw (Control Bracket)
	697116	Piston Assembly (.010" Oversize)	192	691986	Adjuster-Rocker Arm
	697117	Piston Assembly (.020" Oversize)	202	691841	Link-Mechanical Governor
	697118	Piston Assembly (.030" Oversize)	209	692208	Spring-Governor
26	697115	Ring Set (Standard)	216	691840	Link-Choke
	697119	Ring Set (.010" Oversize)	222	694042	Bracket-Control
	697120	Ring Set (.020" Oversize)	227	691374	Lever-Governor Control
	697121	Ring Set (.030" Oversize)	231	691636	Screw (Choke Valve)
27	698469	Lock-Piston Pin	232	691842	Spring-Governor
28	697099	Pin-Piston	238	691843	Cap-Valve
29	697126	Rod-Connecting (Standard)	240	394358	Filter-Fuel
32	692852	Screw (Connecting Rod)	265	691024	Clamp-Casing
33	495856	Valve-Exhaust	267	695134	Screw (Casing Clamp)
34	495857	Valve-Intake	276	692255	Ø‡ Washer-Sealing
35	691279	Spring-Valve (Intake)	304	698402	Housing-Blower
36	691279	Spring-Valve (Exhaust)	305	697102	Screw (Blower Housing)
37	697352	Guard-Flywheel	305A	697103	Screw (Blower Housing)
40	691752	Retainer-Valve	306	697107	Shield-Cylinder
43	691968	Slinger-Governor/Oil	307	691003	Screw (Cylinder Shield)
45	690564	Tappet-Valve	309	693551	Motor-Starter
46	697687	Camshaft	309A	--- --	Motor-Starter (For Replacement Starter Motor, See Reference 309)
48	697761	Short Block (31C707-0239-E2 Replacement Engine-art not available)	310	690323	Bolt (Starter Motor)
50	690193	Manifold-Intake	311	497608	Brush Set
51	692137	•Ø‡± Gasket-Intake	311A	395538	Brush Set
53	690227	Stud (Carburetor)	333	492341	Armature-Magneto
54	691148	Screw (Intake Manifold)	334	691061	Screw (Magneto Armature)
73	697384	Screen-Rotating	337	691043	Plug-Spark
74	697987	Screw (Rotating Screen)	358	697151	Gasket Set-Engine
75	690582	Washer (Flywheel)	363	19203	Flywheel Puller
78	691003	Screw (Flywheel Guard)	383	89838	Wrench-Spark Plug
93	690602	Ø Bushing-Throttle Shaft			RPM Settings: Low Speed: 1900-2100 High Speed: 3000-3200
94	498030	Kit-Idle Mixture			
95	691636	Screw (Throttle Valve)			
98	495800	Kit-Idle Speed			
104	690525	Ø Pin-Float Hinge			• Included in Engine Gasket Set, Key. No. 358
105	231855	Ø Valve-Float Needle			Ø Included in Carburetor Overhaul Kit, Key. No. 121
106	690577	Ø Seat-Inlet			‡ Included in Carburetor Gasket Set, Key. No. 977
					+ Included in Valve Gasket Set, Key. No. 1095





### **LIMITED WARRANTY ON CRAFTSMAN RIDING EQUIPMENT**

For one (1) year from the date of purchase, if this Craftsman Riding Equipment is maintained, lubricated and tuned up according to the instructions in the owner's manual, Sears will repair or replace free of charge any parts that are found to be defective in material or workmanship according to the guidelines of coverage listed below. Sears will also provide free labor for these applicable warranted parts for the one full year. During the first 30 days of purchase, there will be no charges to service the product at your home for issues covered by this warranty. (See exclusions below). For your convenience, IN HOME warranty service will still be available after the first 30 days of purchase, but a trip charge will apply. This charge will be waived if the Craftsman product is dropped off at an authorized Sears location. For the nearest authorized Sears location, please call 1-800-4-MY-HOME®. This warranty applies only while this product is within the United States.

This Warranty does not cover:

- Expendable items which become worn during normal use, including but not limited to blades, spark plugs, air cleaners, belts, and oil filters.
- Standard Maintenance Servicing, oil changes, or tune-ups
- Tire replacement or repair caused by punctures from outside objects, such as nails, thorns, stumps, or glass.
- Repairs necessary because of operator abuse, including but not limited to, damage caused by towing objects beyond the capability of the riding equipment, impacting objects that bend the frame or crankshaft, or over-speeding the engine.
- Repairs necessary because of operator negligence, including but not limited to, electrical and mechanical damage caused by improper storage, failure to use the proper grade and amount of engine oil, failure to keep the deck clear of flammable debris, or failure to maintain the equipment according to the instructions contained in the owner's manual.
- Engine (fuel system) cleaning or repairs caused by fuel determined to be contaminated or oxidized (stale). In general, fuel should be used within 30 days of its purchase date.
- Normal deterioration and wear of the exterior finishes, or product label replacement.
- Riding equipment used for commercial or rental purposes.

### **LIMITED WARRANTY ON BATTERY**

For ninety (90) days from date of purchase, if any battery included with this riding equipment proves defective in material or workmanship and our testing determines the battery will not hold a charge, Sears will replace the battery at no charge. During the first 30 days of purchase, there will be no charges to replace the battery at your HOME. After the first 30 days, for your convenience, IN-HOME warranty service will still be available but a trip charge will apply. This charge will be waived if the Craftsman product is dropped off at an authorized Sears location. For the nearest authorized Sears location, please call 1-800-4-MY-HOME®.

This battery warranty applies only while this product is within the United States.

This warranty gives you specific legal rights, and you may also have other rights, which vary, from state to state.

Sears, Roebuck and Co., Dept. 817WA, Hoffman Estates, IL 60179