

REPAIR PARTS MANUAL
MODEL NO. 277180
Lawn Tractor



HOW TO USE THIS MANUAL

This manual is designed to provide the customer with a means to identify the parts on his/her tractor when ordering repair parts. The illustrations may or may not represent the actual assemblies; therefore, it is not recommended to use this manual as a guide to assemble or disassemble the tractor. Some hardware and parts are drawn larger in order to more readily identify them.

Each tractor has its own model number.

The model number for your tractor can be found on the fender under the seat.

When ordering parts, always give the following information:

- Product - "Tractor"
- Model Number - "277180"
- Part Number
- Part Description

TABLE OF CONTENTS

SCHEMATIC	3
ELECTRICAL.....	4-5
CHASSIS.....	6-7
DRIVE.....	8-9
STEERING	10-11
SEAT	12
DECALS.....	13
ENGINE.....	14
MOWER LIFT	15
MOWER DECK	16-17
BAGGER.....	18-19
TRANSAXLE.....	20-21
ENGINE BREAKDOWN.....	22-27
WARRANTY.....	28

TRACTOR- -MODEL NO. 917.277180

SCHEMATIC

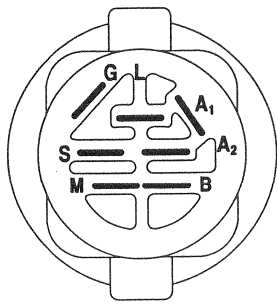
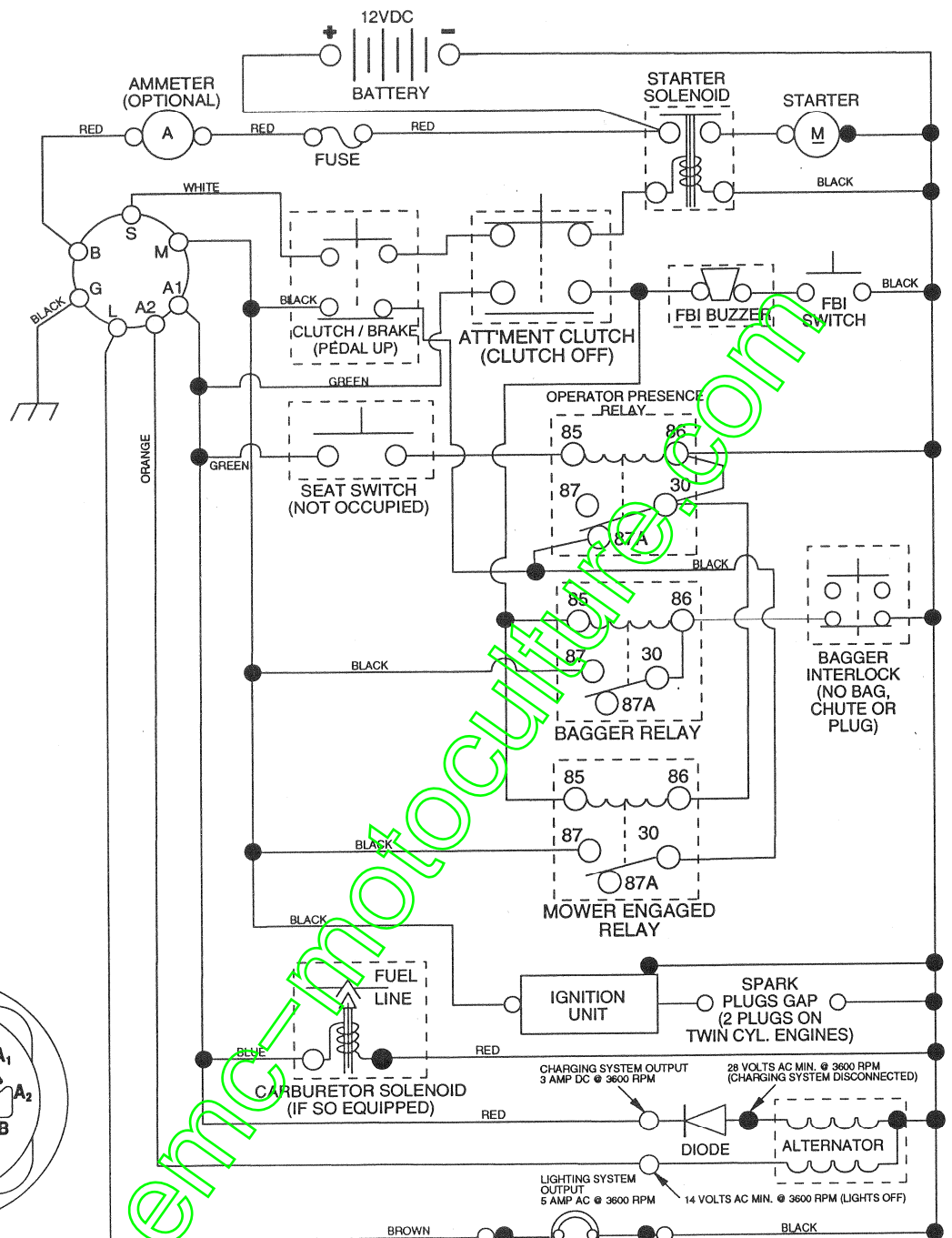

IGNITION SWITCH

POSITION	CIRCUIT	"MAKE"
OFF	M+G+A1	NONE
RUN/LIGHT	B+A1	A2+L
RUN	B+A1	NONE
START	B + S + A1	NONE

WIRING INSULATED CLIPS
NOTE: IF WIRING INSULATED CLIPS WERE REMOVED FOR SERVICING OF UNIT, THEY SHOULD BE REPLACED TO PROPERLY SECURE YOUR WIRING.



PTO SWITCH

POSITION	CIRCUIT
OFF	C + G, B + H
ON	C + F, B + E, A + D

HEADLIGHTS

NOTE
YOUR TRACTOR IS EQUIPPED WITH A SPECIAL ALTERNATOR SYSTEM. THE LIGHTS ARE NOT CONNECTED TO THE BATTERY, BUT HAVE THEIR OWN ELECTRICAL SOURCE. BECAUSE OF THIS, THE BRIGHTNESS OF THE LIGHTS WILL CHANGE WITH ENGINE SPEED. AT IDLE THE LIGHTS WILL DIM. AS THE ENGINE IS SPEEDED UP, THE LIGHTS WILL BECOME THEIR BRIGHTEST.

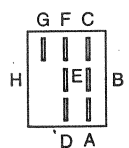
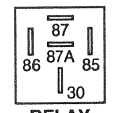

REPAIR PARTS

TRACTOR- -MODEL NO. 917.277180

ELECTRICAL

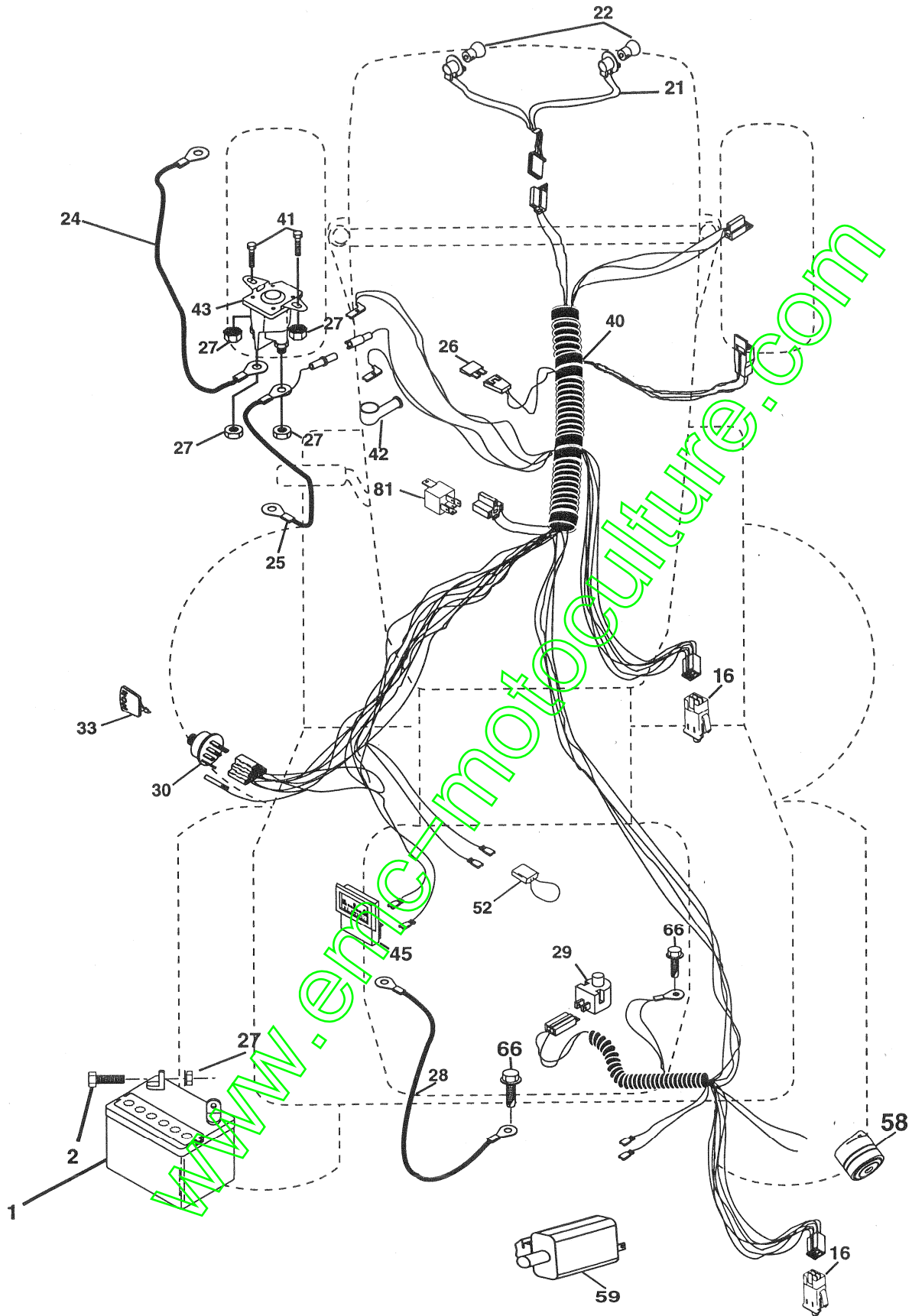

REPAIR PARTS

TRACTOR- -MODEL NO. 917.277180

ELECTRICAL

KEY NO.	PART NO.	DESCRIPTION
1	163465	Battery
2	74760412	Bolt Hex Hd 1/4-20 unc x 3/4
16	176138	Switch Interlock Push-In
21	183759	Harness Asm Light W/4152J
22	4152J	Bulb Light #1156
24	4799J	Cable Starter 6 Ga. 11" Red
25	165987	Cable Battery Crd 56" Red
26	175158	Fuse
27	STD541425	Nut Keps Hex 1/4-20 unc
28	127725X	Cable Ground 6 Ga. 18" Black
29	121305X	Switch Plunger Normal Op Gray
30	175566	Switch Ignition
33	140403	Key Ign Molded
40	188036	Harness Ign Crd Noram
41	71110408	Bolt Flk Fin Hex 1/4-20 unc x 1/2
42	131563	Cover Terminal Red
43	178861	Solenoid
45	121433X	Ammeter Rectangular
52	141940	Protection Wire Loop
58	169419	Buzzer Crd
59	180379	Switch FBI CRD
66	17490608	Screw Thdrol 3/8-16 x 1/2 Ty-Tt
81	109748X	Relay Asm

NOTE: All component dimensions given in U.S. inches.
1 inch = 25.4 mm.

REPAIR PARTS

TRACTOR- -MODEL NO. 917.277180

CHASSIS AND ENCLOSURES

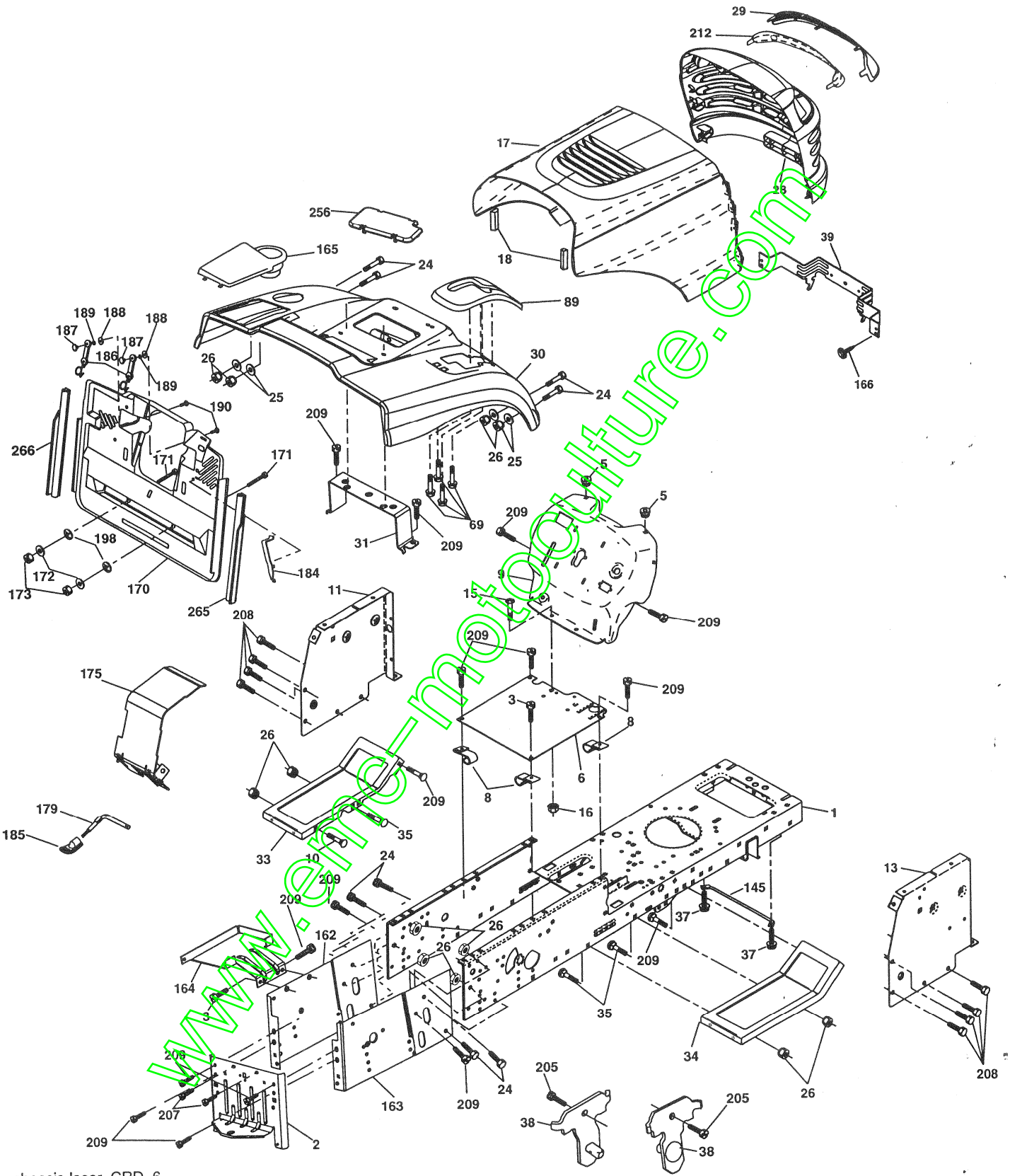

chassis-laser_CRD_6

REPAIR PARTS

TRACTOR- -MODEL NO. 917.277180

CHASSIS AND ENCLOSURES

KEY NO.	PART NO.	DESCRIPTION	KEY NO.	PART NO.	DESCRIPTION
1	174620	Chassis Assembly	145	156524	Rod Pivot Chassis/Hood
2	180384	Drawbar	162	180382	Bracket Exten Chassis Lh CRD
3	17060612	Screw 3/8-16 x .75	163	180383	Bracket Exten Chassis Rh CRD
5	155272	Bumper Hood/Dash	164	165605	Support Battery CRD
6	184419	Saddle	165	179020X428	Cover Battery CRD Lt
8	126471X	Clip Insulator 13/32 Mtg. Hole	166	171875	Screw Hwhd Hi-Lo #13-16 x 5/8
9	168348X013	Dash Silscr	170	178862	Backplate Asm CRD
10	STD533710	Bolt, Carriage 3/8-16 x 1	171	72140620	Bolt Rdhd Sqnk 3/8-16 x 2-1/2
11	174996	Panel, Dash, L.H.	172	19132016	Washer 13/32 x 1-1/4 x 16 Ga.
13	172105X010	Panel, Asm. Dash R.H.	173	STD541437	Nut, Keps Hex 3/8-16 unc
15	74180512	Screw, Machine, Truss Head 5/16-18 UNC x 3/4	175	188203	Door Trap
16	STD541431	Nut Keps 5/16-18 UNC	179	180376	Rod Pivot FBI CRD
17	185682X558	Hood Assembly	184	174662	Bracket Actuator Bagger CRD
18	184921	Bumper Hood	185	179608X505	Knob Rod Brake Parking
24	STD523710	Bolt Fin Hex 3/8-16 unc x 1. Gr 5	186	160793	Latch Asm Mulch/Bagger
25	19131312	Washer 13/32 x 13/16 x 12 Gauge	187	2029J	Nut Weld .327/.304 #10-24
26	STD541437	Nut Lock Hex w/lns 3/8-16 unc	188	19064216	Washer #10
28	190380	Grille/Lens Asm (Includes key #'s 29 and 212)	189	STD551110	Washer Lock #10
29	174332X599	Lens, Grille	190	71081010	Screw Pan Hd Phillips 10-24
30	169962X588	Fender	198	168937	Nut, Push
31	165156	Bracket, Fender Support	205	17490608	Screw Thdrol 5/8-16 x 1/2
33	179716X558	Footrest, L.H.	207	17670508	Screw Thdrol 5/16-18 x 1/2
34	179717X558	Footrest, R.H.	208	17670608	Screw Thdrol 3/8-16 x 1/2 TYT
35	STD533107	Bolt RDHD SHT SQNK 3/8-16 x 3/4	209	17000612	Screw Hex Wsh Thdrol 3/8-16
37	17490508	Screw Thdrol 5/16-18 x 1/2 TYT	212	175143	Insert Lens Reflective
38	181748	Pivot Bracket Assembly	256	180810X428	Cover Fender Rack
39	174714	Bracket Pivot	265	185704	Seal Side RH
69	142432	Screw Hex 1/4-1/2 Unc	266	185703	Seal Side LH
89	177287X428	Console	--	5479J	Plug, Button

NOTE: All component dimensions given in U.S. inches.
1 inch = 25.4 mm.

REPAIR PARTS

TRACTOR- -MODEL NO. 917.277180

DRIVE

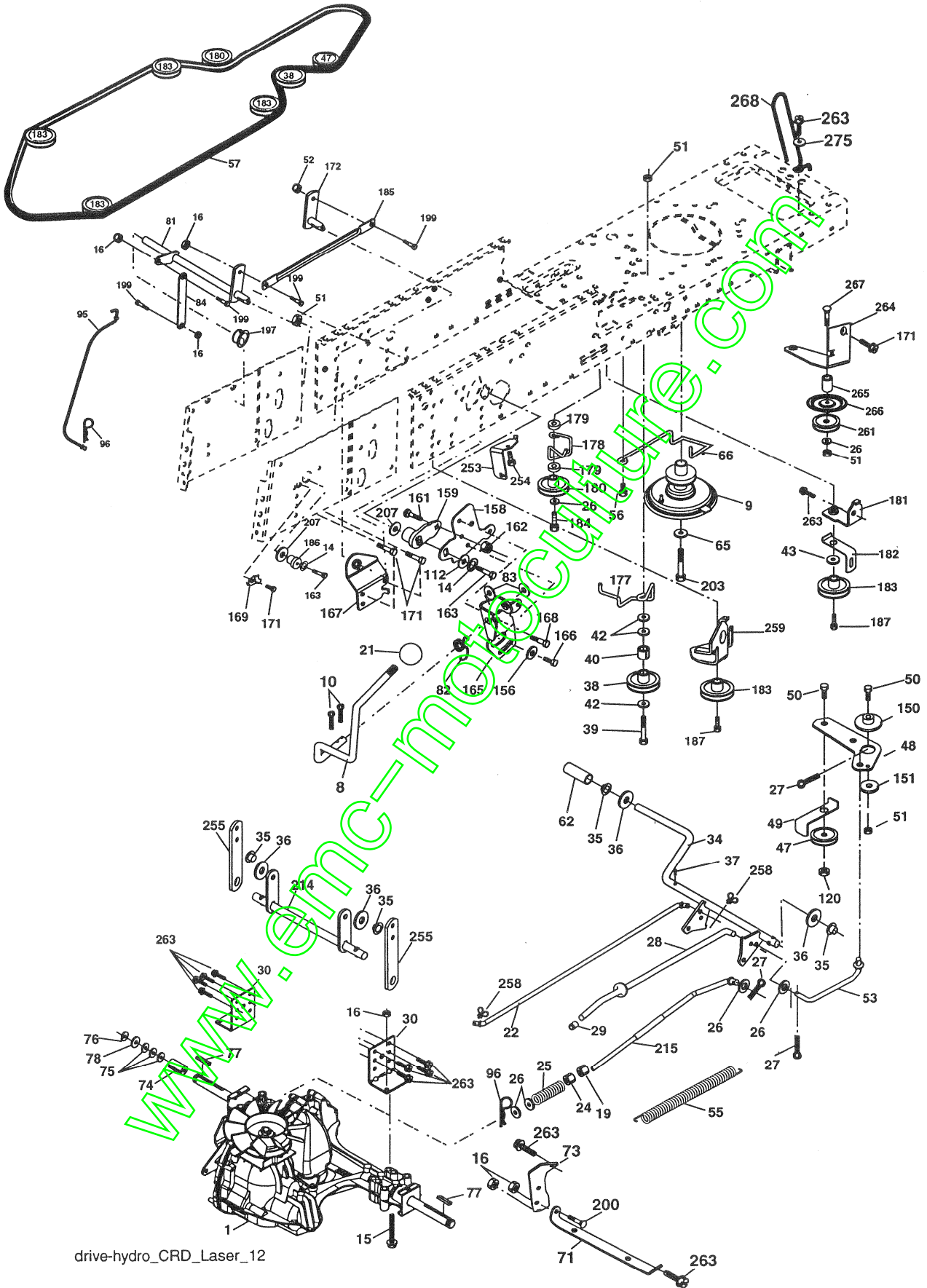

drive-hydro_CRD_Laser_12

REPAIR PARTS

TRACTOR- -MODEL NO. 917.277180

DRIVE

KEY NO.	PART NO.	DESCRIPTION	KEY NO.	PART NO.	DESCRIPTION
1	-----	Transaxle Hydro Gear 321-0510 (See Breakdown))	112	19091210	Washer 9/32 x 3/4 x 10 Ga.
8	165619	Rod, Shift Fender Adjust Lt	120	73900600	Nut Lock Flg. 3/8-16 unc
9	180354	Clutch	150	165850	Bushing, Bellcrank Grnd Dr.
10	76020416	Pin, Cotter 1/8 x 1	151	19133210	Washer 13/32 x 2 x 10 Ga.
14	10040400	Washer, Lock Hvy Helical	156	166002	Washer Srrted 5/16ID x 1.125
15	74490544	Bolt Hex FGHD 5/16-18 x Gr. 5	158	165589	Bracket Shift Mount
16	73800500	Nut, Lock Hex w/lns 5/16-18 unc	159	183900	Hub Shift
19	73800600	Nut, Lock Hex w/lns. 3/8-16	161	72140406	Bolt Rdhd Sqnk 1/4-20 x 3/4 Gr. 5
21	130564	Knob	162	73680400	Nut Crownlock 1/4-20 unc
22	175607	Rod, Brake	163	74780416	Bolt Hex Fin 1/4-20 unc x 1 Gr. 5
24	73350600	Nut	165	165623	Bracket Pivot Lever
25	106888X	Spring, Rod, Brake	166	17490510	Screw 5/16-18 x 5/8
26	19131316	Washer 13/32 x 13/16 x 16 Ga.	167	165588	Bracket Support Shift CRD
27	76020412	Pin, Cotter 1/8 x 3/4	168	165492	Bolt Shoulder 5/16-18 x .561
28	175765	Rod, Parking Brake	169	165580	Plate Fastening Lt
29	71673	Cap, Parking Brake	171	17490608	Screw Thdrol 3/8-16 x 1/2 Ty-Tt
30	169592	Bracket, Mfg. Transaxle	172	170271	Shaft Asm Shifter Frt CRD
34	175578	Shaft, Asm Pedal Foot CRD	177	165932	Keeper Flat Idler 3.06" CRD
35	120183X	Bearing, Nylon	178	165933	Keeper Belt Idler 1.88" CRD
36	19211616	Washer 21/32 x 1 x 16 Ga.	179	120958X	Washer Sintered
37	1572H	Pin, Roll 3/16 x 1"	180	165630	Pulley, Idler, Flat 1.88"CRD
38	165936	Pulley Flat Composite 3.06"	181	180211	Bracket Idler Ground Drive CRD
39	74760644	Bolt Fin Hex 3/8-16 unc x 2-3/4	182	182682	Keeper Belt 2.5" Od V-Idler CRD
40	4470J	Spacer, Split 395 x 59 Bzp	183	186007	Pulley V-Idler 2.50" Od CRD
42	19131312	Washer 13/32 x 13/16 x 12 Ga.	184	17490644	Screw Hexwsh Thdrol 3/8-16 x 2-3/4
43	19111012	Washer 11/32 x 5/8 x 12 Ga.	185	170008	Link Shift
47	127783	Pulley, Idler, V Groove Plasic	186	165614	Hub Tapered Round CRD
48	154407	Bellcrank Clutch Grnd Drv	187	17580520	Screw Thdrol 5/16-18 x 1.25
49	123205X	Retainer, Belt Style Spring	197	169613	Nyliner Snap-In 5/8
50	72110612	Bolt, Carr. 3/8-16 x 1/2 x Gr. 5	199	169612	Bolt Shoulder 5/16-18 unc
51	73680600	Nut, Crownlock 3/8-16 unc	200	72140508	Bolt RDHD SQNK 5/16-18 x 1
52	73680500	Nut Crownlock 5/16-18	203	71170780	Bolt Hex 7/16-20 x 5
53	105710X	Link, Clutch 7.66	207	169845	Washer Nylon Rear
55	105709X	Spring, Return, Clutch	214	175609	Shaft Asm. Brake
56	17060620	Screw 3/8-16 x 1-1/4	215	175652	Rod Brake Hydro
57	170140	V-Belt Kev 112" 0650 CRD	253	175028	Bracket, Cable
62	8883R	Cover, Pedal	254	1700016	Screw 3/8-16 x 1
65	10040700	Washer	255	175608	Brace Shaft Brake Mtg.
66	154778	Keeper, Belt Engine F-Proof	258	178062	Clip Retainer
71	169183	Strap, Torque, Lh	259	180212	Bracket Pulley
73	169182	Strap, Torque, Rh	261	131494	Pulley Idler Flat
74	137057	Spacer, Split	263	17000612	Screw 3/8-16 x 3/4
75	121749X	Washer 25/32 x 1-1/4 x 16 Ga.	264	181995	Bracket Clutch
76	12000001	Ring, E	265	182013	Spacer, Idler
77	123583X	Key, Square	266	182061	Shield, Idler
78	121748	Washer 25/32 x 1-5/8 x 16 Ga.	267	72140626	Bolt Carr. 3/8-16 x 3-1/4
81	170006	Asm, Shaft	268	182402	Guard Muffler
82	165711	Spring, Torsion	275	19131614	Washer 13/32 x 1 x 14 Ga.
83	19171216	Washer 17/32 x 3/4 x 16 Ga.			
84	170007	Link, Transaxle			
95	170015	Control Asm Bypass Hydro			
96	4497H	Spring, Retainer 1"			

NOTE: All component dimensions given in U.S. inches
1 inch = 25.4 mm

REPAIR PARTS

TRACTOR- -MODEL NO. 917.277180

STEERING ASSEMBLY

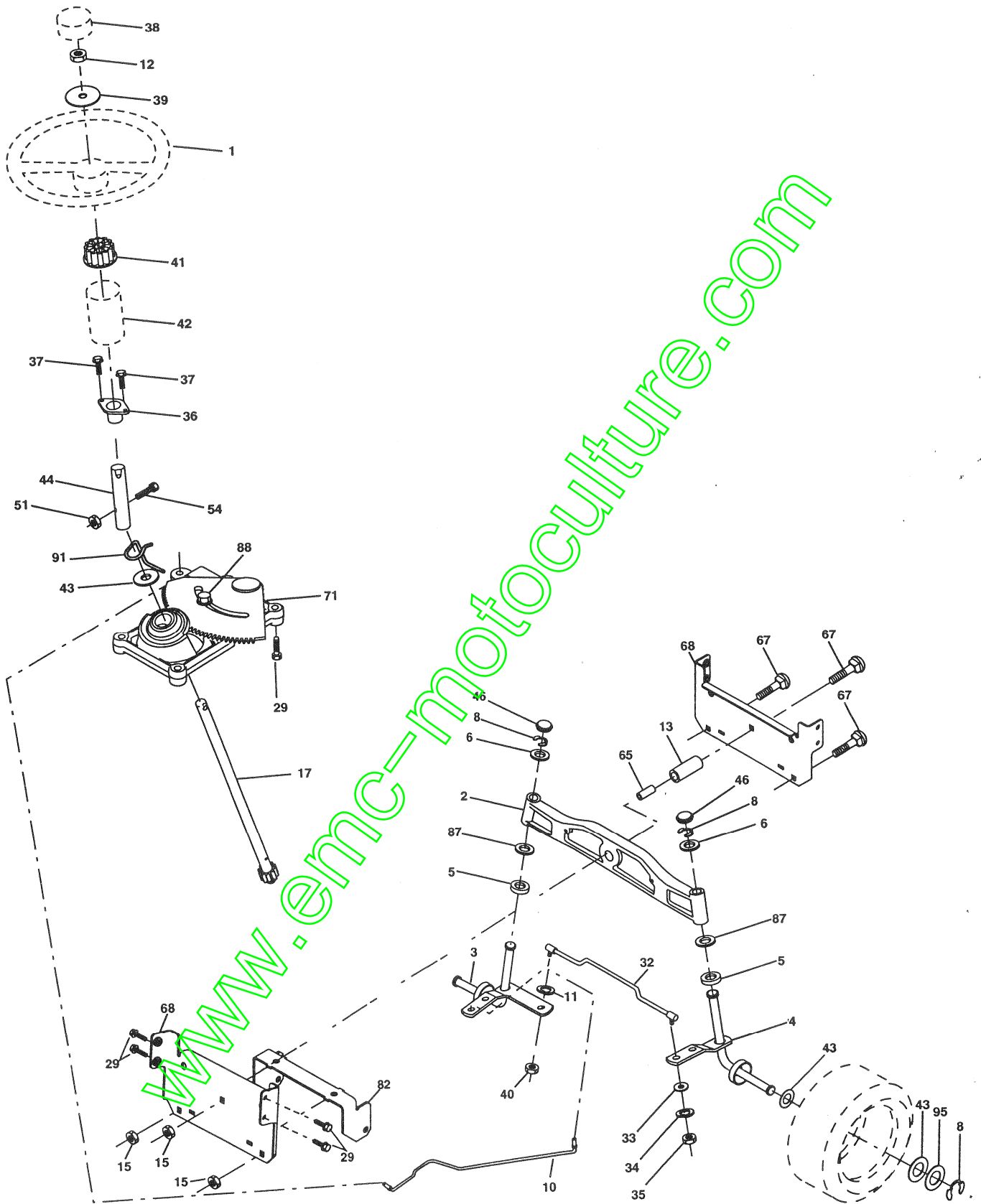

steering_pl.lt_29

REPAIR PARTS

TRACTOR- -MODEL NO. 917.277180

STEERING ASSEMBLY

KEY NO.	PART NO.	DESCRIPTION
1	139768	Steering Wheel
2	184706	Front Axle Assembly
3	169840	Spindle Assembly, L.H.
4	169839	Spindle Assembly, R.H.
5	6266H	Bearing, Race, Thrust, Hardened
6	121748X	Washer 25/32 x 1-5/8 x 16 Ga.
8	12000029	Ring, Klip
10	175121	Link, Drag
11	STD551137	Washer, Lock
12	73940800	Nut Hex Jam Toplock 1/2-20 unf
13	136518	Spacer Axle
15	145212	Nut, Hexflange Lock
17	180641	Shaft Assembly, Steering
29	17000612	Screw, 3/8-16 x 3/4 SMGM Tap/R
32	170162	Rod, Tie
33	19111216	Washer 11/32 x 3/4 x 16 Ga.
34	10040500	Washer Lock Hvy Hicl Spl 5/16
35	73540500	Nut Crownlock 5/16-24 Unf
36	155099	Bushing, Steering
37	152927	Screw TT #10-32 x 5 x 3/8 Flange
38	139769	Cap Wheel Steering
39	19183812	Washer 9/16 ID x 2-3/8 OD 12 Ga.
40	73540600	Nut Crownlock 3/8-24
41	186737	Adaptor, Steering Wheel
42	145054X428	Boot, Steering Dash
43	121749X	Washer 25/32 x 1-1/4 x 16 Ga.
44	180640	Extension Steering Non-Adjust
46	184946X505	Cap, Spindle
51	73540400	Nut Crownlock 1/4-28
54	71130420	Bolt 1/4-28 UNF x 1-1/4 Ga. 8
65	160367	Spacer Brace Axle
67	72110618	Bolt RDHD SQ 3/8-16 x 2-1/4
68	169827	Brace Axle
71	175146	Steering Asm.
82	169835	Bracket Susp Chassis Front
87	173966	Washer FLat .781 x 1-1/2 x .14
88	175118	Bolt Shoulder
91	175553	Clip Steering
95	188967	Washer Harden .739 x 1.637 x 060

NOTE: All component dimensions given in U.S. inches.
1 inch = 25.4 mm.

REPAIR PARTS

TRACTOR- -MODEL NO. 917.277180

SEAT ASSEMBLY

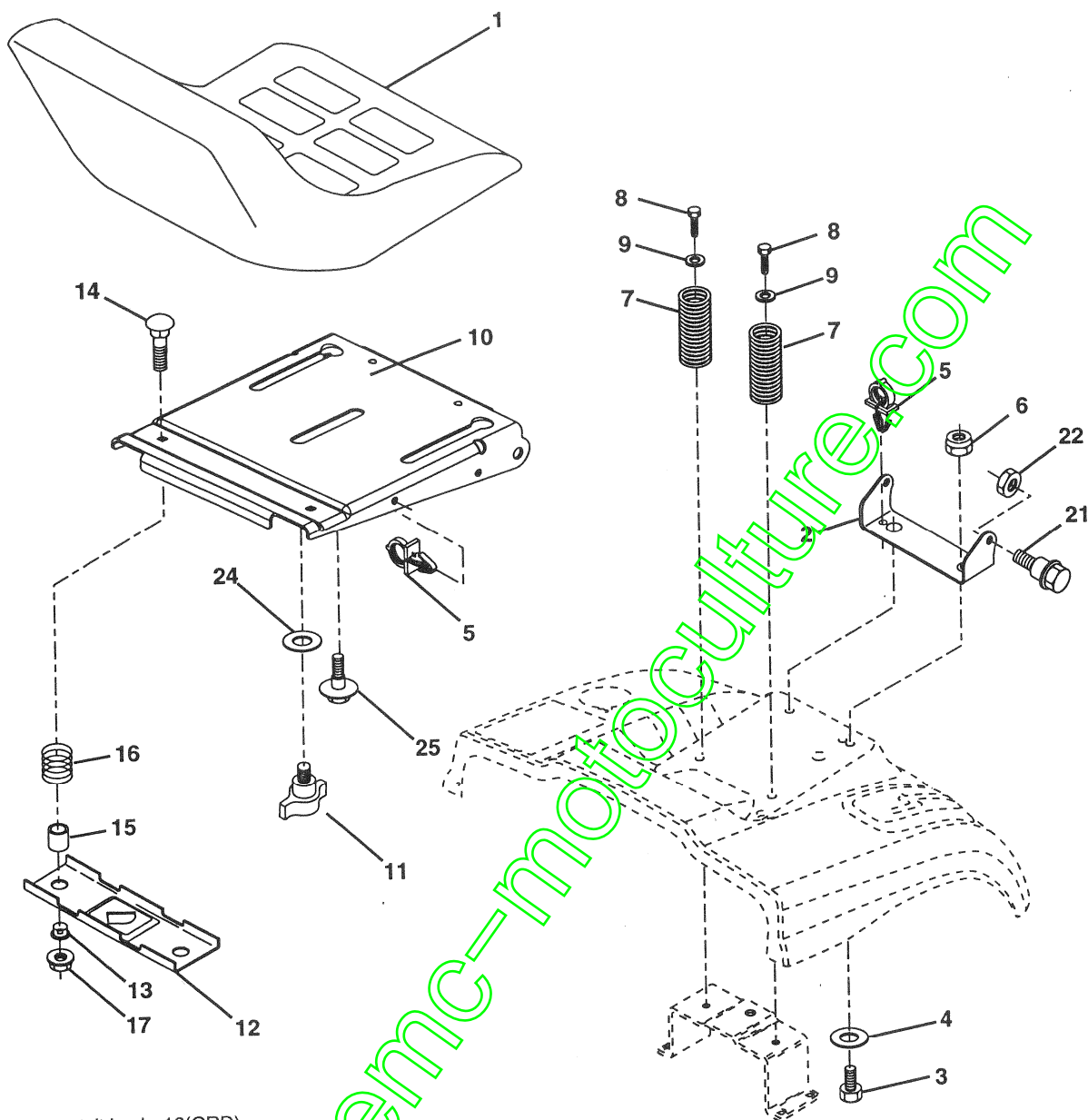

seat_lt.knob_16(CRD)

KEY NO.	PART NO.	DESCRIPTION
1	188716	Seat
2	180166	Bracket Pnt Pivot Seat (blk)
3	71110616	Bolt Fin Hex 3/8-16 unc x 1
4	19131610	Washer Flat 13/32 x 1 x 10 Ga.
5	145006	Clip Push In Hinged
6	73800600	Nut Lock Hex 3/8-16 Unc
7	124181X	Spring Seat Cprsn 2 250 Blk Zi
8	17000616	Screw 3/8-16 x 1
9	19131614	Washer 13/32 x 1 x 14 Ga.
10	180186	Pan Pnt Seat
11	166369	Knob Seat Adj Wingnut
12	121246X	Bracket Pnt Mounting Switch

KEY NO.	PART NO.	DESCRIPTION
13	121248X	Bushing Snap Blk Nyl 50 Id
14	72050412	Bolt Rdhd Sht Nk 1/4-20 x 1-1/2
15	134300	Spacer Split .28 x .96 Zinc
16	121250X	Spring Cprsn
17	123976X	Nut Lock 1/4 Lge Fig Gr. 5 Zinc
21	171852	Bolt Shoulder 5/16-18 unc-2A
22	73800500	Nut Hex Lock w/lns 5/16-18
24	19171912	Washer 17/32 x 1-3/16 x 12 Ga.
25	127018X	Bolt Shoulder 5/16-18 x 62

NOTE: All component dimensions given in U.S. inches, 1 inch = 25.4 mm

REPAIR PARTS

TRACTOR- -MODEL NO. 917.277180

DECALS

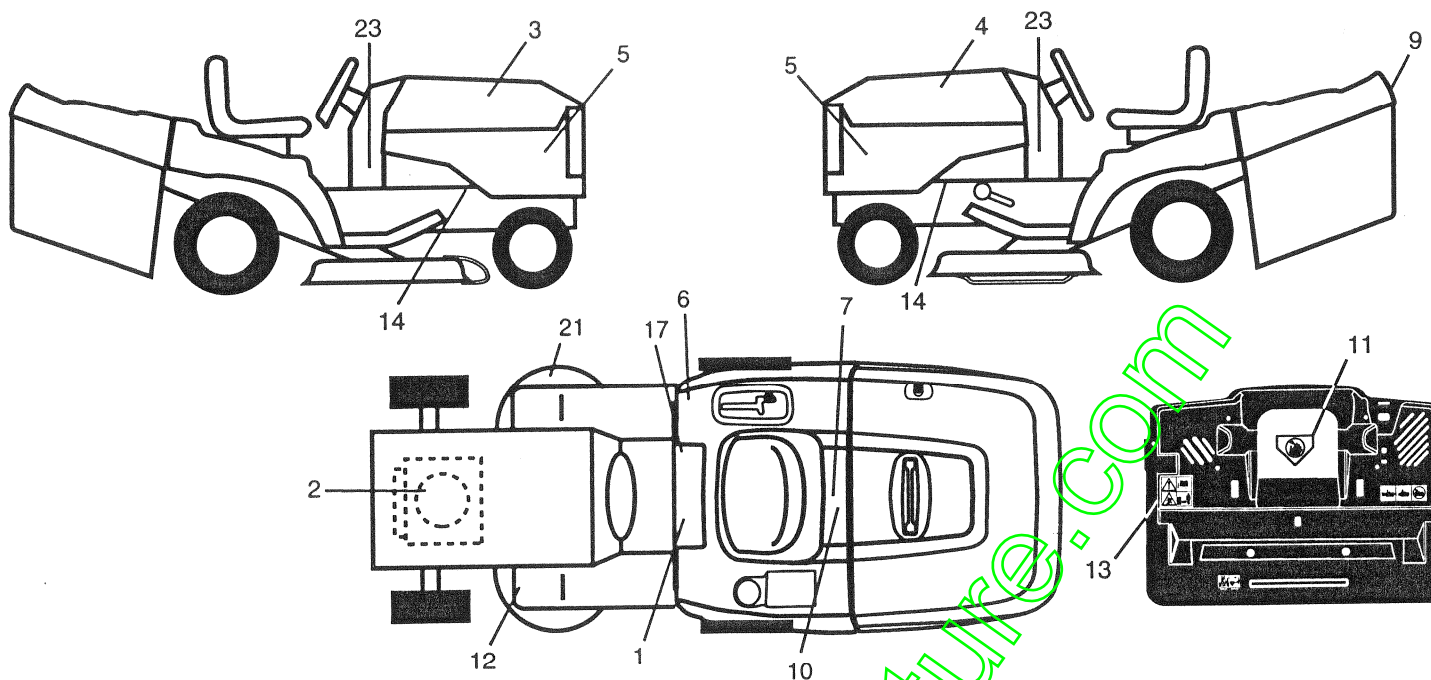

KEY NO.	PART NO.	DESCRIPTION
1	145498	Decal Read Owner's Manual Sym
2	184847	Decal Hp Engine
3	184728	Decal Hood Rh
4	184729	Decal Hood Lh
5	184730	Decal Hood Side LT 1000
6	180432	Decal 100 DB/CE
7	166960	Decal Bypass Fender
9	184899	Decal Fender Logo
10	145005	Decal Bat Dan/Poi P/L Sym Wpn
11	182166	Decal Mower Cut Finger Symbol
12	159737	Decal Brake/Clutch Symbol Lt
13	180435	Decal Warn Back Plate CRD Sym-

KEY NO.	PART NO.	DESCRIPTION
14	159736	Decal Chassis Hot Muffler
17	140837	Decal Saddle Brake Parking
21	166286	Decal Deck Sch 92 CRD
23	181685	Decal Panel Dash
---	138311	Decal Lift Handle
---	179768X428	Pad Footrest LH
---	182621	Decal Bagger Frame Assy
---	179769X428	Footrest Pad RH
---	190721	Manual Operator's (Euro)
---	190722	Manual Operator's (Scand)
---	190723	Manual Parts

WHEELS & TIRES

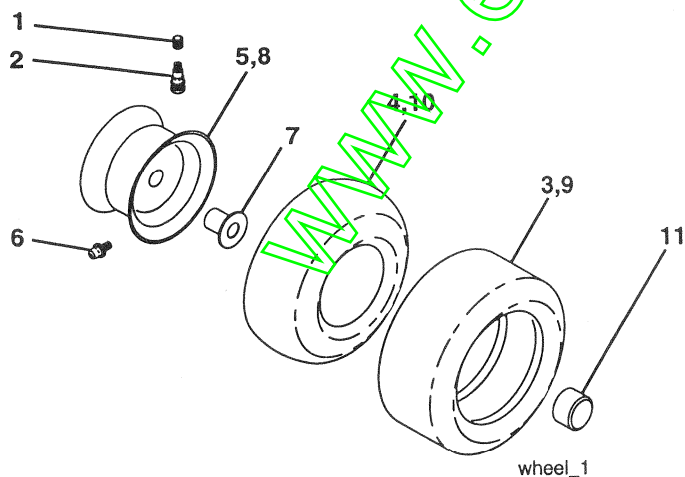

KEY NO.	PART NO.	DESCRIPTION
1	59192	Cap Value Tire
2	65139	Stem Value
3	106222X	Tire F Ts 15 x 6 0 - 6 Service
4	59904	Tube Inner Front #35060
5	106732X624	Rim Asm 6" front White Service
6	278H	Fitting Grease
7	9040H	Bearing Flange
8	106108X624	Rim Asm 8" rear White Service
9	106268X	Tire R Ts 18 x 9.5-8 Service
10	7152J	Tube Rear 9 5 x 8 Service
11	104757X428	Cap Axle Blk 1 50 x 1 00
--	144334	Sealant, Tire (10 oz. tube)

NOTE: All component dimensions given in U.S. inches
1 inch = 25.4 mm

REPAIR PARTS

TRACTOR- -MODEL NO. 917.277180

ENGINE

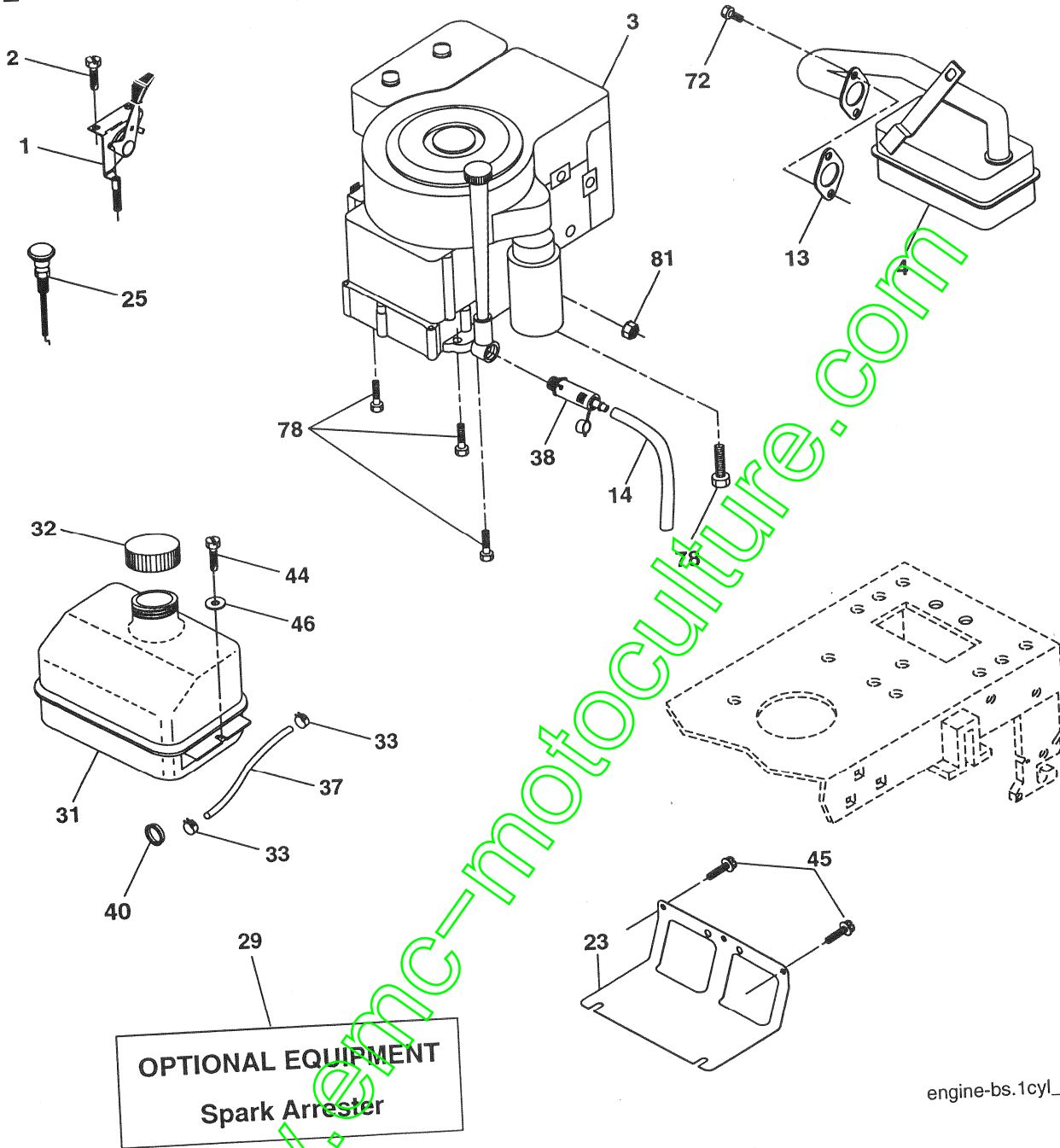

engine-bs.1cyl_38

KEY NO.	PART NO.	DESCRIPTION
1	170545	Control Throttle/Choke
2	17720408	Screw Hex Thd Cut 1/4-20 x 1/2
3	-----	Engine (See Breakdown) Briggs Model 282H07-0239-E1
4	137352	Muffler Exhaust B&S Lt
13	165291	Gasket 1 313 Id Tin Plated
14	148456	Tube Drain Oil Easy
23	169837	Shield Browning/Debris Guard
25	180945	Control Choke
26	73920600	Nut Keps
29	137180	Arrestor Spark
31	184900	Tank Fuel 1.25 Fr
32	140527	Cap Asm Fuel

KEY NO.	PART NO.	DESCRIPTION
33	123487X	Clamp Hose Blk
37	137040	Line Fuel 20"
38	181654	Plug Oil Drain Easy
40	124028X	Bushing Snap
44	17670412	Screw Hexwsh Thdrol 1/4-20 x 3/4"
45	17000612	Screw Hexwsh Thdr 3/8-16 x 3/4"
46	19091416	Washer 9/32 x 7/8 x 16 Ga.
72	183906	Screw Socket Head 5/16-18 x 1
78	17060620	Screw 3/8-16 x 1-1/4
81	73510400	Nut Keps 1/4-20 unc

NOTE: All component dimensions given in U.S. inches
1 inch = 25.4 mm

REPAIR PARTS

TRACTOR- -MODEL NO. 917.277180

MOWER LIFT

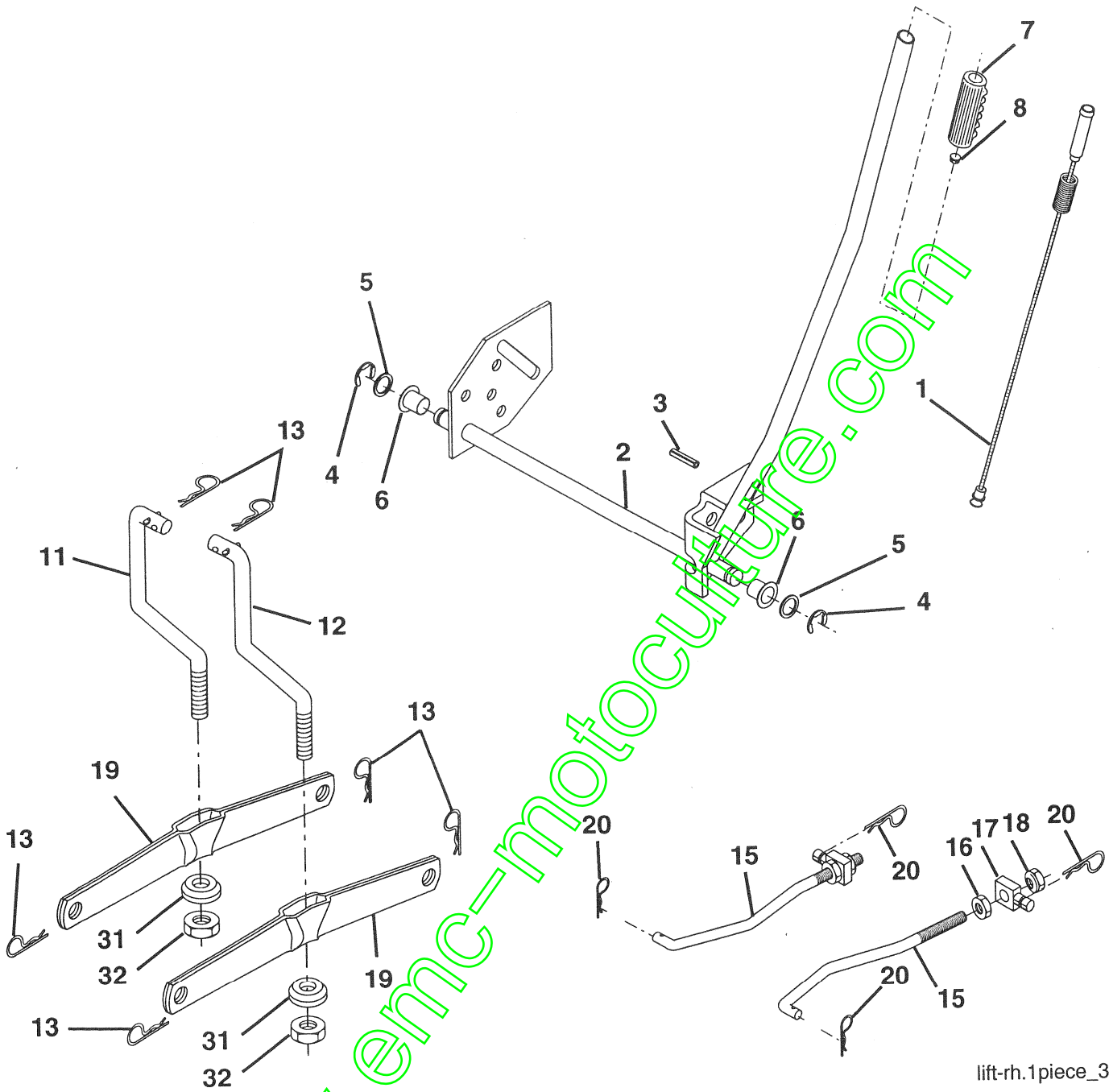

KEY NO.	PART NO.	DESCRIPTION
1	159460	Washer Asm Inner Spring W/Plunger
2	159471	Shaft Asm. Lift
3	105767X	Pin Groove
4	STD581062	E Ring #5133-62
5	19211621	Washer 21/32 x 1 x 21 Ga.
6	120183X	Bearing Nylon
7	125631X	Grip Handle
8	124526X	Button Plunger Black
11	165829	Link Asm Lift L.H.
12	165831	Link Asm Lift R.H.

KEY NO.	PART NO.	DESCRIPTION
13	STD624008	Retainer Spring
15	173288	Link Front
16	73350800	Nut Jam Hex 1/2-13 unc
17	175689	Trunnion Blk Zinc
18	73800800	Nut Lock w/wsh 1/2-13 unc
19	139868	Arm Suspension Mower
20	163552	Retainer Spring
31	169865	Bearing, Pvt. Lift.
32	73540600	Nut Crownlock 3/8-24

NOTE: All component dimensions given in U.S. inches
1 inch = 25.4 mm

REPAIR PARTS

TRACTOR- -MODEL NO. 917.277180

MOWER

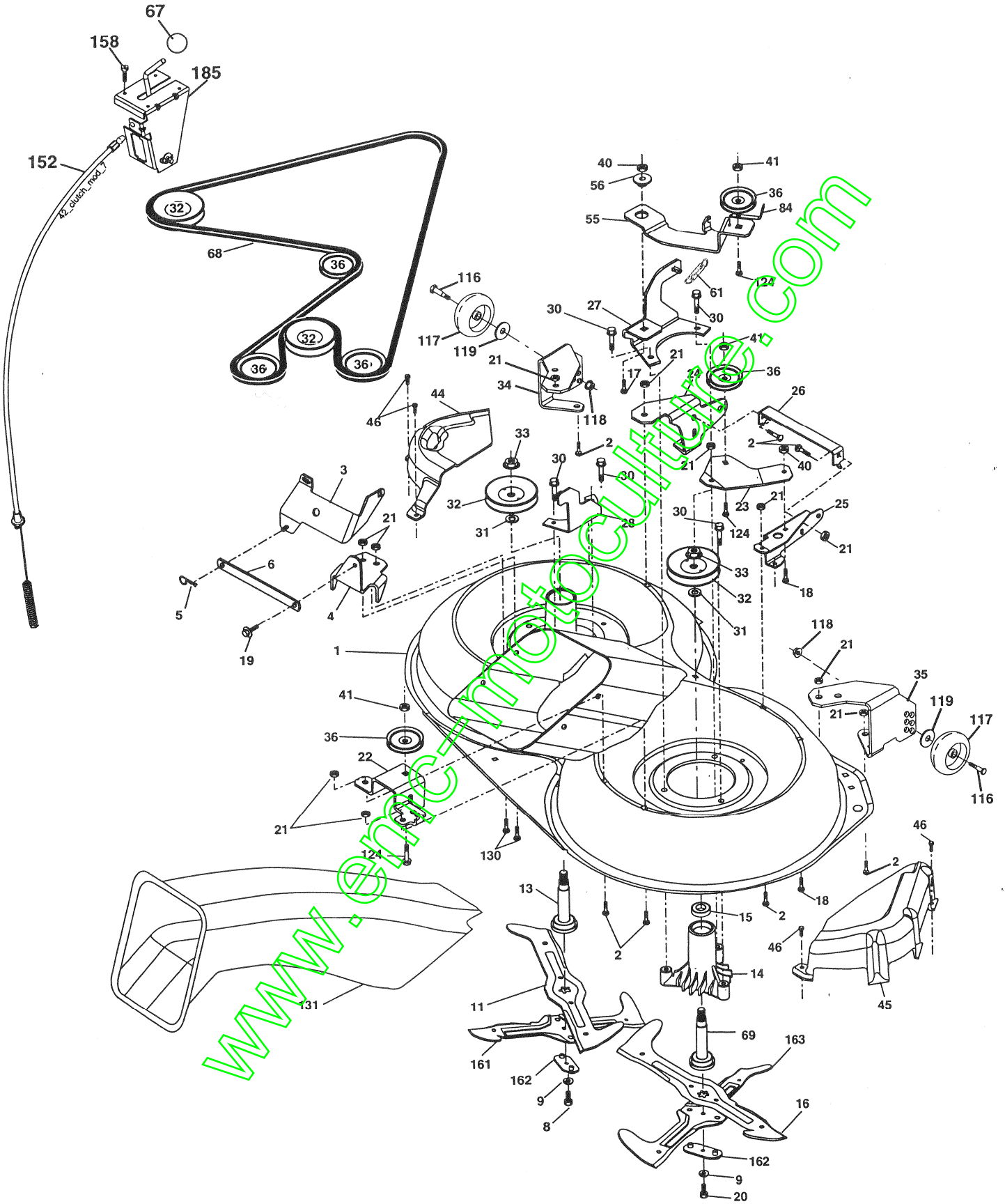

REPAIR PARTS

TRACTOR- -MODEL NO. 917.277180

MOWER

KEY NO.	PART NO.	DESCRIPTION	KEY NO.	PART NO.	DESCRIPTION
1	165552	Housing Asm. Mower 92 CRD	46	137729	Screw Thd Roll 1/4-20 x 5/8
2	72140506	Bolt Rdhd Sqnk 5/16-18 unc x 3/4	55	165445	Arm Idler 92 CRD
3	165569	Bracket Asm. S-Bar Chass 92 CRD	56	165723	Spacer Retainer Mower
4	165558	Bracket Bar Sway Deck 92 CRD	61	165945	Spring Tension Belt
5	4939M	Retainer Spring	67	106932X	Knob Rd 3/8-16 Plstdc Thds Blk
6	165557	Bar Sway 92 CRD	68	180217	Hex-Belt 92 Mower
8	181712	Bolt 3/8-24 x 1.25 Gr. 8 Patched	69	165482	Shaft Asm W/Lwr Brg Rh Thd CRD
9	10030600	Washer Lock Hvy 3/8 Unplated	84	156085	Keeper Belt Idler
11	186385	Blade 3-1 Lh 92 CRD	116	184219	Bolt Shoulder
13	137645	Shaft Asm. W/Lower Bearing	117	133957	Wheel Gage Donut Wide
14	128774	Housing Mandrel Vented (Machd)	118	73930600	Nut Centerlock 3/8-16 unc
15	110485X	Bearing Ball Mandrel	119	19121414	Washer 3/8 x 7/8 x 14 Ga.
16	186386	Blade 3-1 Rh 92 CRD	124	72110612	Bolt Carr Sh 3/8-16 x 1-1/2 Gr. 5
17	72140610	Bolt Carriage 3/8-16 x 1-1/4	130	72110506	Bolt Rdhdsqnk 5/16-18 unc x 3/4
18	72110606	Bolt Rdhd Sqnk 3/8-16 x 3/4	131	165661	Chute Bagger CRD 92 cm
19	132827	Bolt Shoulder 5/16-18 Thd Form	151	169670	Bracket Clutch Cable
20	181713	Bolt 3/8-24 x 1.25 Gr. 8 Ptch Lhthd	152	176074	Cable Clutch CRD Service
21	73680500	Nut Crown Lock 5/16-18	153	169674	Washer Flat 3/8" Type B
22	165243	Bracket Idler Sprt RR 92 CRD	154	169675	Spring Retainer
23	165446	Bracket Idler Sprt RF 92 CRD	155	169671	Spring Retention Lvr Clutch Cable
24	165242	Bracket Suspension LF 92 CRD	156	169672	Spacer Clutch Cable
25	165244	Bracket Suspension RF 92 CRD	157	169669	Rod Clutch Cable 3/8"
26	165237	Brace Support Susp Frt CRD	158	17720408	Screw Thd Cut 1/4-20 x 1/2
27	165568	Bracket Asm. Susp RR 92 CRD	161	186387	Blade Cross LH
28	165567	Bracket Asm. Susp LR 92 CRD	162	180878	Adapter Blade Cross
30	173984	Screw Thd Rolling Washer Head	163	186388	Blade Cross RH
31	187690	Washer Spacer	--	181857	Mandrel Asm Service (Includes Housing, Shaft and Shaft Hardware Only - Pulley Not Included)
32	153531	Mandrel Pulleys 36 & 46			
33	178342	Nut Flg Top Lock Cntr B 9/16			
34	165239	Bracket Gauge Wheel Lf 92 CRD	--	181858	Mandrel Asm CRD Lh Threads SVC
35	165238	Bracket Gauge Wheel Rf 92 CRD	--	188523	Replacement Mower Complete (Order separately gauge wheel components key nos. 116-119)
36	146763	Pulley Idler V-Groove Dim 4.25			
37	19131316	Washer 11/32 x 13/16 x 16 Ga.			
40	73680600	Nut Crownlock 3/8-16 unc			
41	73900600	Nutlock Flg 3/8-16 unc			
44	175538	Cover Mandrel Lh 92 CRD			
45	175539	Cover Mandrel Rr 92 CRD			

NOTE: All component dimensions given in U.S. inches
1 inch = 25.4 mm

REPAIR PARTS

TRACTOR- -MODEL NO. 917.277180

BAGGER

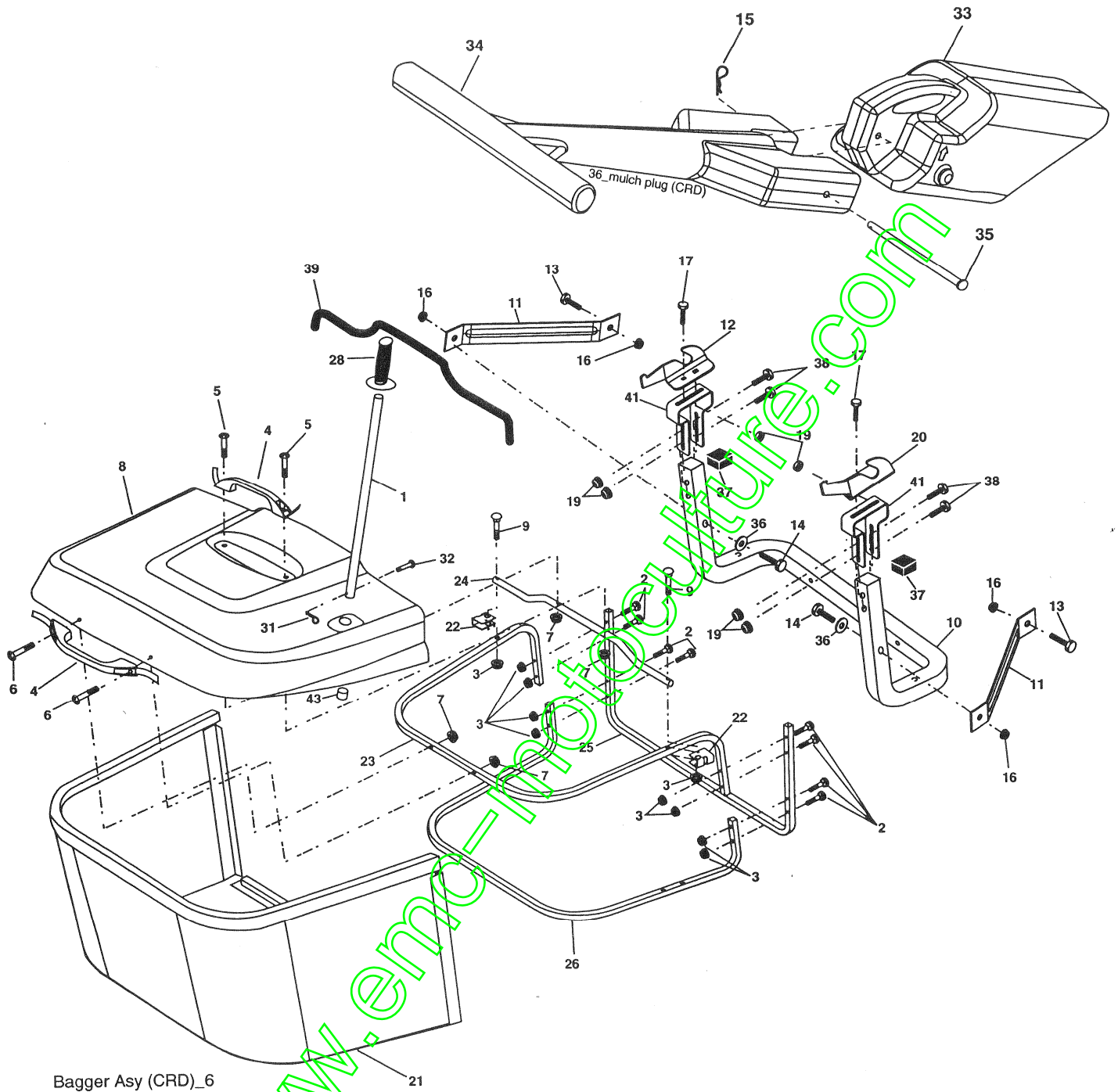

REPAIR PARTS

TRACTOR- -MODEL NO. 917.277180

BAGGER

KEY NO.	PART NO.	DESCRIPTION
1	165249	Tube Handle Bagger CRD
2	72140416	Bolt Carriage 1/4-20 x 2.0 Gr. 5
3	123976X	Nut Lock 1/4 Lge Flg Gr. 5 Zinc
4	169916	Handle Bagger
5	74981024	Screw Pan Head #10-24 x 1.50 Blk
6	74981032	Screw Pan Hd
7	73401000	Nut Wiz Lock Hex Serr/Hd 10-24
8	169963X558	Cover Bagger Steel CRD
9	72140418	Bolt Carriage 1/4-20 x 2.25d x Gr. 5
10	181282	Tube Support Bagger CRD
11	165719	Bracket Support Upper Bag CRD
12	188848	Bracket Pivot Bagger Lh CRD
13	STD533707	Bolt Rdhd Sht Sqnk 3/8-16 x 3/4
14	74520636	Bolt Hex 3/8-16 x 2-1/4 Gr. 5
15	4939M	Retainer Spring
16	73900600	Nut Lock Flg 3/8-16 unc
17	STD533107	Bolt Rdhd Sht Sqnk 5/16 -18 unc x 3/4
19	73900500	Nut Lock Hex Flange 5/16-18
20	188847	Bracket Bagger RH CRD
21	180880	Bag Asm CRD
22	165781	Bracket Side Bagger CRD
23	165782	Tube Upper Bagger CRD
24	165783	Tube Pivot Bagger CRD
25	180124	Tube Front Bagger CRD
26	165785	Tube Lower Bagger CRD
28	165787	Grip Handle Black
31	STD624003	Retainer Spring 1" Zinc/Cad
32	126875X	Rivet Rd Hd Drilled 3/8 Dia
33	165571	Plug Mulcher
34	165570	Handle Mulcher
35	165572	Pin Mulcher
36	19132016	Washer 13/32 x 1-1/4 x 16 Ga.
37	175401	Plug Support Bagger CRD
38	72010520	Bolt 5/16-18 x 5.20
39	180985	Seal 37"
41	169683	Bracket Vert Adj Bagger CRD
42	STD541431	Nut Lock Hex W/Ins 5/16-18 unc Pl
43	174083	Plug Tubing End

NOTE: All component dimensions given in U.S. inches
1 inch = 25.4 mm

REPAIR PARTS

TRACTOR- -MODEL NO. 917.277180

TRANSAXLE HYDRO GEAR - MODEL NUMBER 321-0510

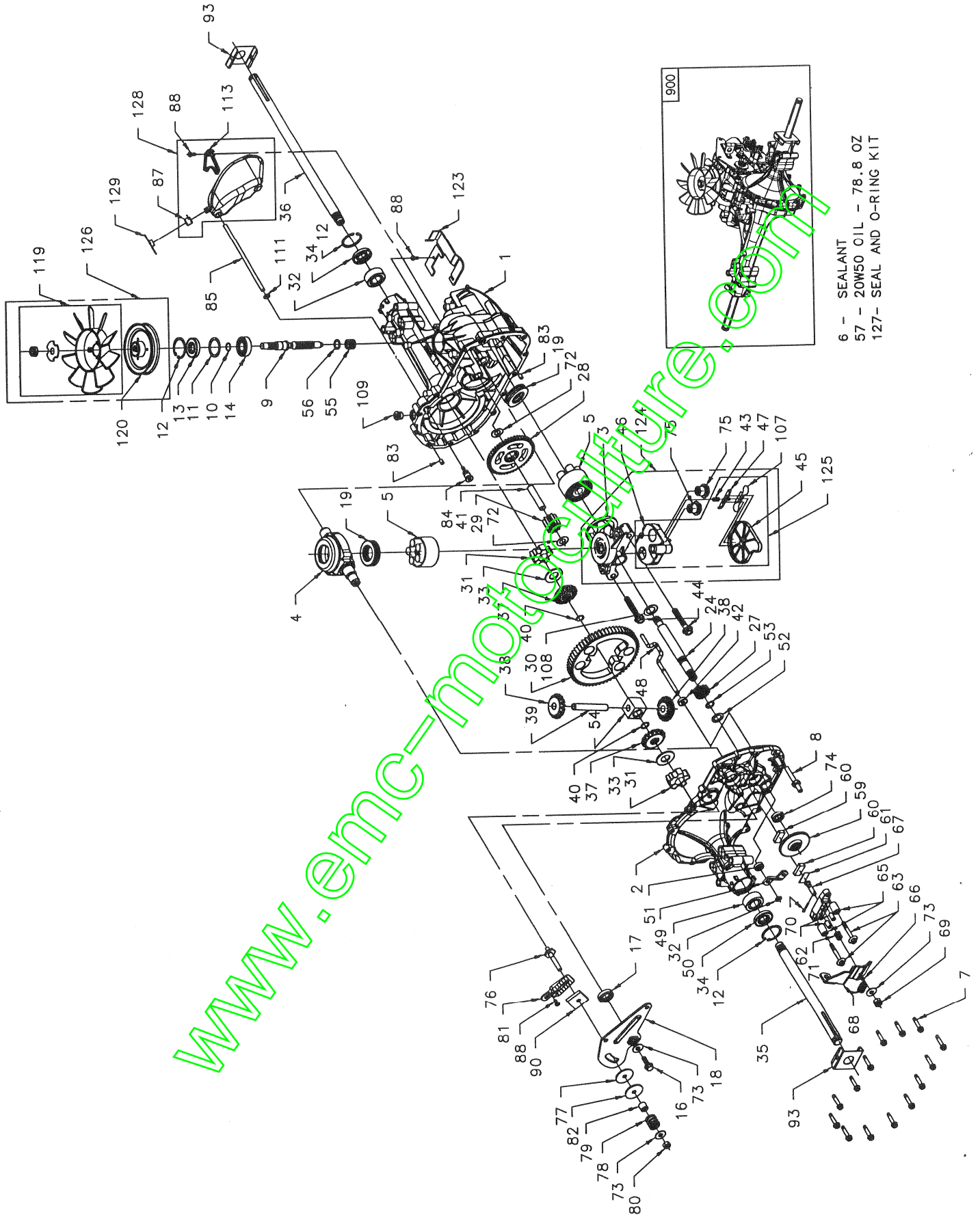

- 6 - SEALANT
- 57 - 20W50 OIL - 78.8 OZ
- 127- SEAL AND O-RING KIT

REPAIR PARTS

TRACTOR- -MODEL NO. 917.277180

TRANSAXLE HYDRO GEAR - MODEL NUMBER 321-0510

KEY NO.	PART NO.	DESCRIPTION	KEY NO.	PART NO.	DESCRIPTION
1	170351	Kit, Main Housing	67	170413	Bolt, Square Head - Brake
		Main Housing, Machined	68	178157	Arm, Brake
		Bushing .855 X .985 X .790	69	170415	Nut, Castle 5/16-24
2	170352	Kit, Side Housing, Side Housing, Machined, Bushing .865 X .985 X .790	70	170416	Pin, Cotter 3/32x3/4
		Bushing .624 X .719 X .562	71	170417	Brake Spring
3	170353	Kit, Center Section, Center Section, Machined, Bushing .707 X .788 X .591	72	170418	Washer (310-0750)
4	170354	Swashplate, Trunnion Machined	73	142884	Washer, Flat
5	169898	Kit, Cylinder Block (10cc), Block - Cylinder, Piston, Spring, Compression Washer - Thrust	74	170419	Seal, Oil
6	178322	Sealant Tube	75	170420	Ass'y Check Plug
7	170356	Hexflange Screw 1/4-20 X 1.25	76	170421	Bolt, Stud 5/16-24
8	170357	Stud, 5/16-24 Hex Double End	77	170422	Puck, Friction
9	170358	Shaft, Input	78	142969	Spring
10	170359	Retaining Ring	79	142980	Spacer
11	170360	Spacer	80	150778	Nut, Nylon Insert Hex Lock 5/16-24
12	169870	Retaining Ring	81	170423	Wedge, Friction
13	170361	Seal, Lip .67 X 1.58 X .276	82	170424	Clip, Washer
14	173158	Bearing, Ball 6203 (Bdr)	83	161168	Pin
16	170362	Hex Flange Head Screw 1/4-20 X 1.25	84	170425	Fitting, 5/16 X Sae 5/32 Tube
17	170363	Seal, Lip 18 X 32 X 7	85	170426	Hose, Expansion Tank
18	170364	Arm, Control	87	173160	Cap, Vent
19	173159	Bearing, Thrust (10cc)	88	178334	Bolt, Self Tapping (BDR)
24	170366	Shaft Motor	90	170430	Puck, Inner Wedge
27	170367	Gear, Pinion, 13t	91	170431	Spring Clip, Housing
28	170368	10t / 48t Gear	107	170432	Deflector
29	170369	Gear, 10t Jackshaft	108	170433	Washer, Motor Shaft .71id X 1.15od X .03 Thick
30	170370	60t Bullgear	109	170434	Plug, Straight Thread 9/16-18
31	170371	Sleeve Bearing .75 X 1.75 X .625	111	170435	O-ring .7 X .301 Id
32	170389	Sleeve Bearing (Outboard) .75 X 1.575 X .625	113	170437	Bracket, Support Expansion Tank
33	142991	Washer	119	191031	Kit, Fan - Washer - Nut, Washer, Od Slotted .53 X 1.63 X .06, Hex Lock Nut 1/2-20 (Nylon Insert), Fan 7"
34	170390	Lip Seal, Axle Shaft	120	178159	Pulley
35	170391	Shaft, Axle (Keyed, R.h.)	123	178160	Bracket, Belt Keeper
36	170392	Shaft, Axle (Keyed, L.h.)	124	191033	Kit, Centersection, Filter Bypass, Center Section Machining, Base Filter W/ Poppet, Check Plug Assembly, .027 Washer
37	150792	Gear, Splined Diff. (210-1000 & 310-0750)			Spring, Bypass, Actuator, Bypass Deflector, Bottom, Filter
38	150793	Gear, Miter Diff. (210-1000 & 310-0750)	125	170445	Bushing, .707 X .788 X .591
39	150809	Differential Shaft (310-0750)			Kit, Filter, Bottom, Filter, Base, Filter W/ Poppet, Spring, Bypass, Actuator, Bypass, Deflector
40	170393	Retaining Ring	126	191029	Kit, Fan/pulley, Hex Jam 1/20-20 (Nylon Insert), Washer, OD Slotted, .53 X 1.53 X .06, Fan, 7 In, Pulley
41	170394	Pin, Jackshaft	127	170447	Kit, Seal
42	170395	Magnet, Ring			Lip Seal .67 X 1.58 X .276
43	170396	Spring, Bypass			Lip Seal 18 X 32 X 7
44	150797	Bolt 3/8-24 X 2-1/2			Lip Seal .706 X 1.584 X .25
45	170397	Filter			Lip Seal .741 X .250 X .250 Tc
46	170398	Base, Filter			Oil Seal .625 X 1.0 X .25
47	170399	Actuator, Bypass			O-ring .07 X .301 ID
48	170400	Rod, Bypass Actuator	128	173165	Kit, Expansion Tank
49	178156	Arm, Bypass			Tank, Expansion Assembly
50	170402	Retaining Ring, 25 External			Cap, Vent
51	170403	Seal, Lip .741 X .25 X .25			Vsbolt, Self Tapping 10-32 X 1/2
52	170404	Washer, Flat .050" (210-1000)			Bracket, Support Expansion Tank
53	170405	Retaining Ring	129	191032	Cap, Expansion Tank Shipping
54	170406	Bearing, Center Block	900	170061	Transaxle
55	142977	Spring, Helical Compression			
56	142978	Washer, Block Thrust			
57	---	20W-50 0 1 78.80oz			
58	142929	Kit, Brake Yoke			
59	170408	Rotor, Brake			
60	142883	Brake Puck			
--	142882	Brake Puck Plate			
62	170409	Pin, Brake Actuating			
63	170410	Hfhcs 1/4-20 X 2 W/patch, Special Flg			
65	170411	Spacer, Brake Torsion Spring			
66	188297	Spring, Brake Arm Bias			

NOTE: All Component Dimensions Given In U.S. Inches 1 Inch = 25.4 mm

REPAIR PARTS

TRACTOR- -MODEL NO. 917.277180

BRIGGS & STRATTON ENGINE - - MODEL NUMBER 282H07, TYPE NUMBER 0239-E1

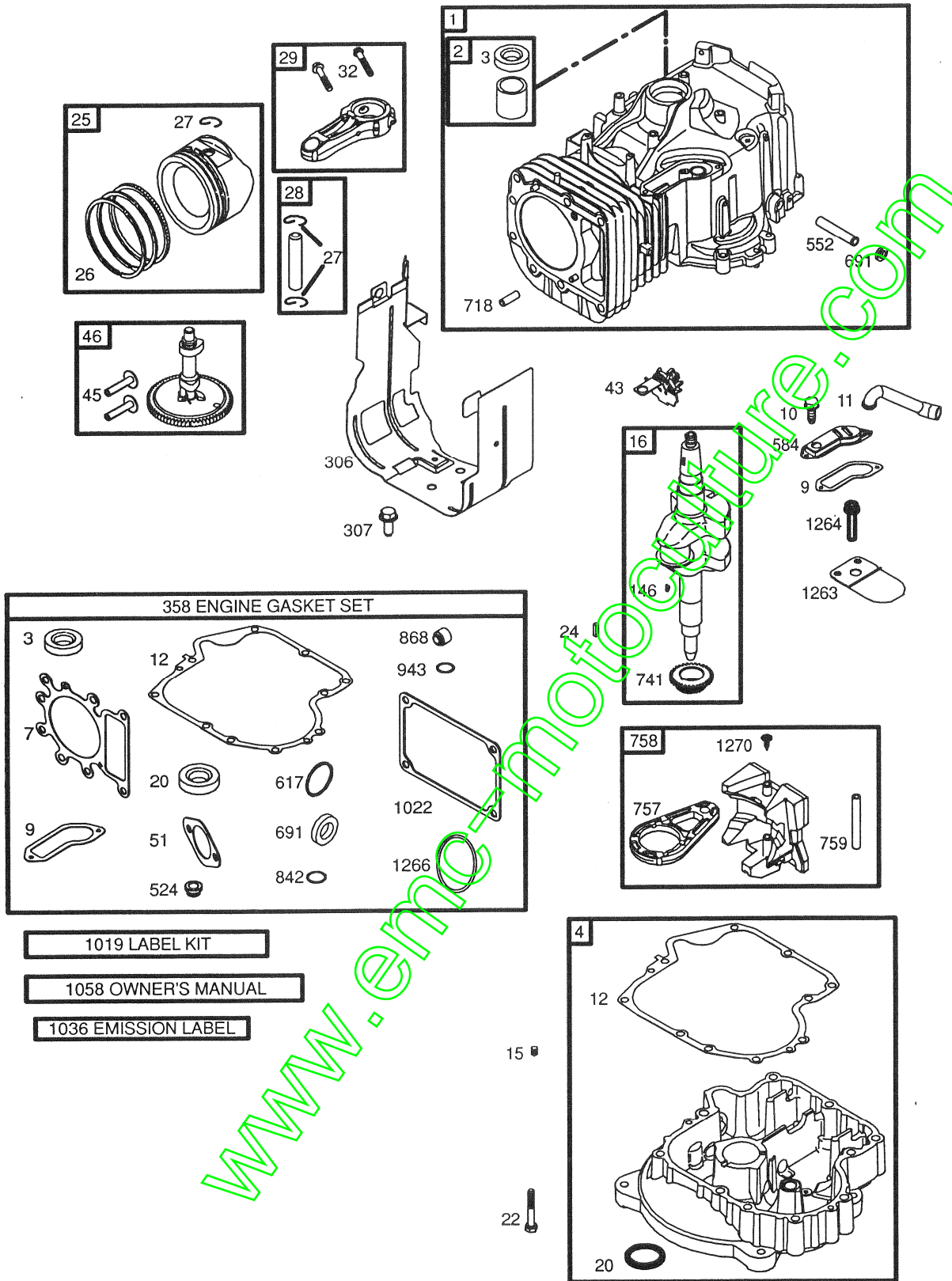

REPAIR PARTS

TRACTOR- -MODEL NO. 917.277180

BRIGGS & STRATTON ENGINE - - MODEL NUMBER 282H07, TYPE NUMBER 0239-E1

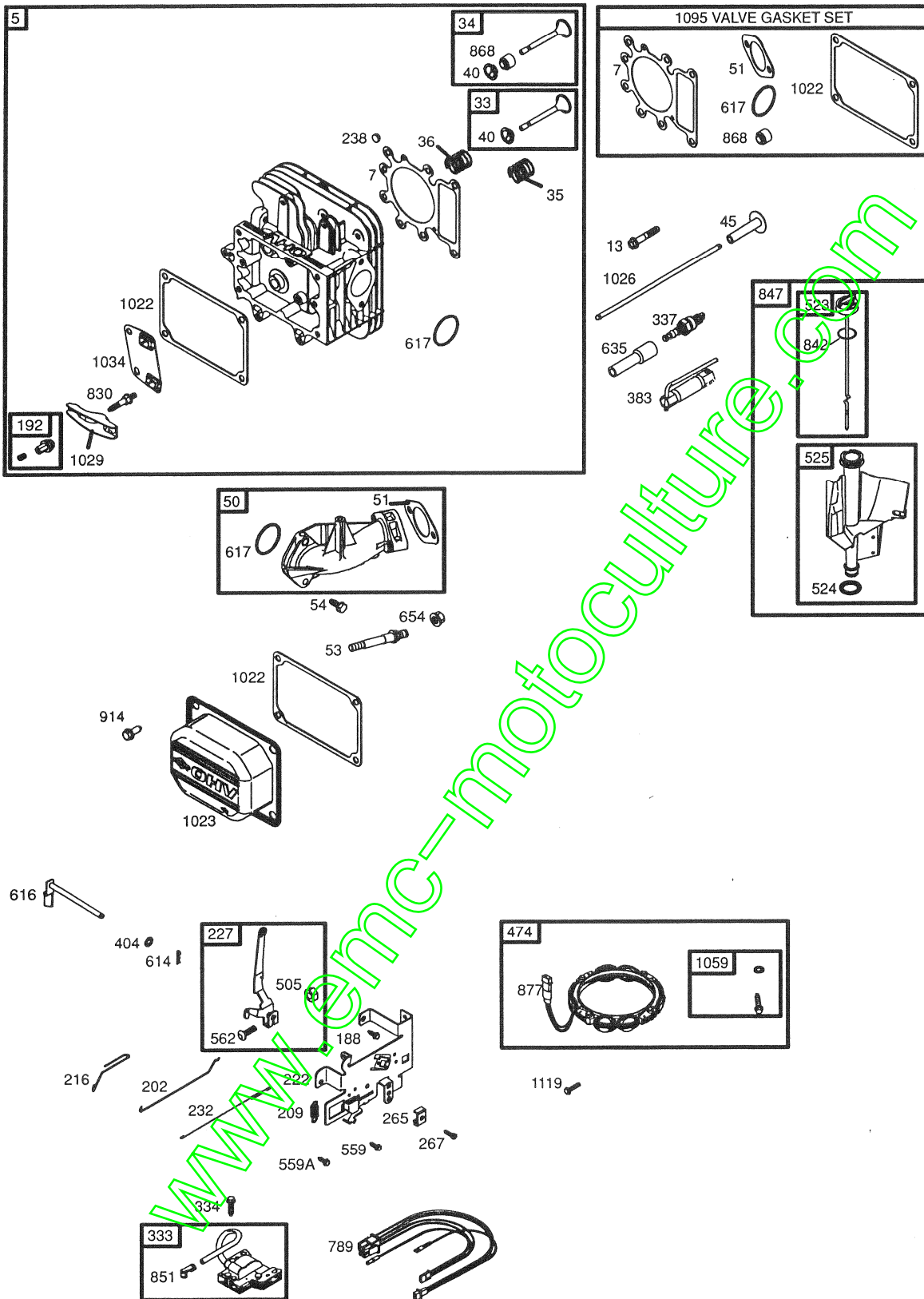

REPAIR PARTS

TRACTOR- -MODEL NO. 917.277180

BRIGGS & STRATTON ENGINE - - MODEL NUMBER 282H07, TYPE NUMBER 0239-E1

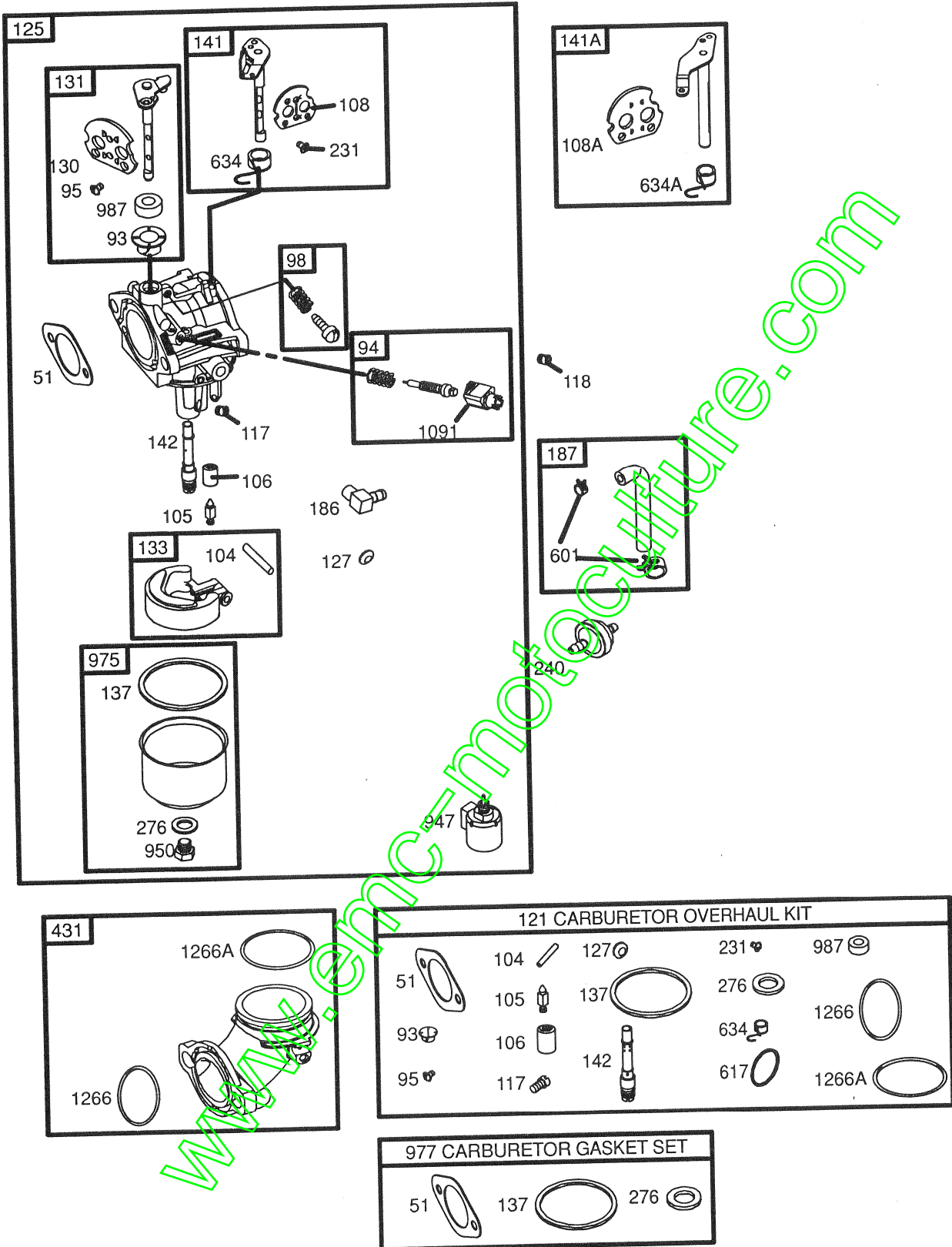

REPAIR PARTS

TRACTOR- -MODEL NO. 917.277180

BRIGGS & STRATTON ENGINE - - MODEL NUMBER 282H07, TYPE NUMBER 0239-E1

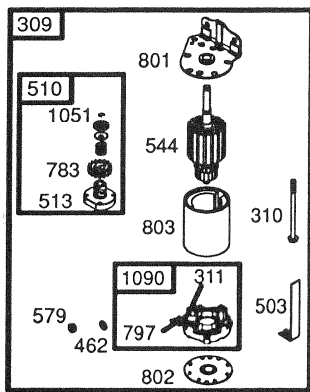
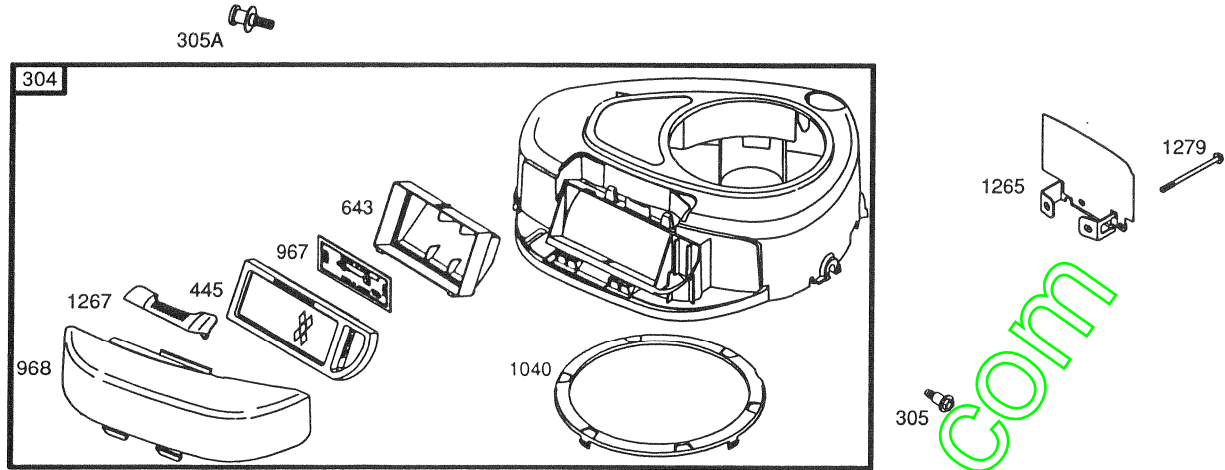

729 697

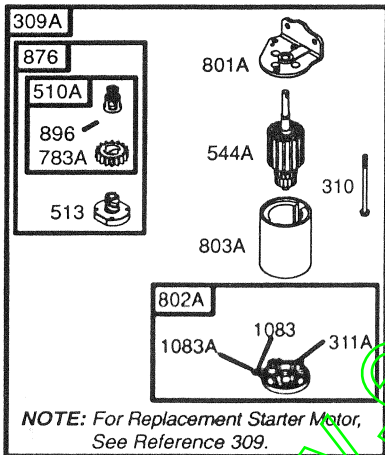
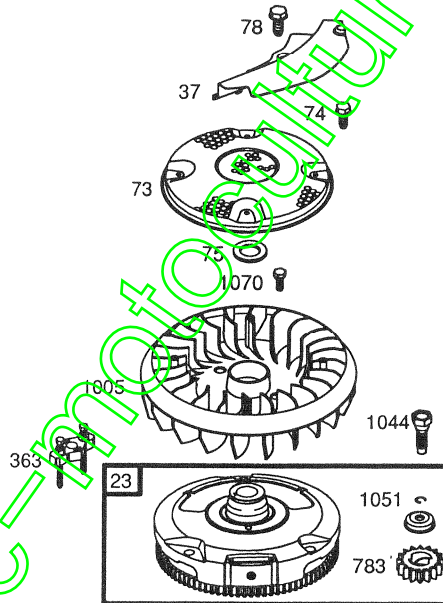

REPAIR PARTS

TRACTOR- -MODEL NO. 917.277180

BRIGGS & STRATTON ENGINE - - MODEL NUMBER 282H07, TYPE NUMBER 0239-E1

KEY NO.	PART NO.	DESCRIPTION	KEY NO.	PART NO.	DESCRIPTION
1	697132	Cylinder Assembly	108	690464	Valve-Choke (Manual Choke)
2	399265	Kit-Bushing/Seal (Magneto Side)	108A	692344	Valve-Choke (Choke A Matic)
3	391086	• Seal-Oil (Magneto Side)	117	694352	Ø Jet-Main (Standard)
4	697106	Sump-Engine	118	697228	Jet-Main (High Altitude)
5	698148	Head-Cylinder	121	697241	Kit-Carburetor Overhaul
7	273280	*+ Gasket-Cylinder Head	125	697190	Carburetor
9	697109	• Gasket-Breather	127	695005	Plug-Welch
10	697157	Screw (Breather Assembly)	130	691750	Valve-Throttle
11	697113	Tube-Breather	131	494379	Kit-Throttle Shaft
12	697110	• Gasket-Crankcase	133	494381	Float-Carburetor
13	690360	Screw (Cylinder Head)	137	281165	Ø‡ Gasket-Float Bowl
15	690946	Plug-Oil Drain	141	495097	Kit-Choke Shaft (Manual Choke)
16	697127	Crankshaft	141A	495931	Kit-Choke Shaft (Choke A Matic)
20	690947	• Seal-Oil (PTO Side)	142	697140	Ø Nozzle-Carburetor
22	692125	Screw (Crankcase Cover/Sump)	146	691639	Key-Timing
23	693557	Flywheel	186	698174	Connector-Hose
24	222698	Key-Flywheel	187	697098	Line-Fuel
25	697114	Piston Assembly (Standard)	188	691693	Screw (Control Bracket)
	697116	Piston Assembly (.010" Oversize)	192	691986	Adjuster-Rocker Arm
	697117	Piston Assembly (.020" Oversize)	202	691841	Link-Mechanical Governor
	697118	Piston Assembly (.030" Oversize)	209	692208	Spring-Governor
26	697115	Ring Set (Standard)	216	691840	Link-Choke
	697119	Ring Set (.010" Oversize)	222	694042	Bracket-Control
	697120	Ring Set (.020" Oversize)	227	691974	Lever-Governor Control
	697121	Ring Set (.030" Oversize)	231	691636	Screw (Choke Valve)
27	698469	Lock-Piston Pin	232	691842	Spring-Governor
28	697099	Pin-Piston	238	691843	Cap-Valve
29	697126	Rod-Connecting (Standard)	240	394358	Filter-Fuel
32	692852	Screw (Connecting Rod)	265	691024	Clamp-Casing
33	495856	Valve-Exhaust	267	695134	Screw (Casing Clamp)
34	495857	Valve-Intake	276	692255	Ø‡ Washer-Sealing
35	691279	Spring-Valve (Intake)	304	698402	Housing-Blower
36	691279	Spring-Valve (Exhaust)	305	697102	Screw (Blower Housing)
37	697352	Guard-Flywheel	305A	697103	Screw (Blower Housing)
40	691752	Retainer-Valve	306	697107	Shield-Cylinder
43	691968	Slinger-Governor/Oil	307	691003	Screw (Cylinder Shield)
45	690564	Tappet-Valve	309	693551	Motor-Starter
46	697687	Camshaft	309A	-----	Motor-Starter (For Replacement Starter Motor, See Reference 309)
48	697761	Short Block (31C707-0230-E2 Replacement Engine-art not available)	310	690323	Bolt (Starter Motor)
			311	497608	Brush Set
50	690193	Manifold-Intake	311A	395538	Brush Set
51	692137	•Ø‡+ Gasket-Intake	333	492341	Armature-Magneto
53	690227	Stud (Carburetor)	334	691061	Screw (Magneto Armature)
54	691148	Screw (Intake Manifold)	337	691043	Plug-Spark
73	697384	Screen-Rotating	358	697151	Gasket Set-Engine
74	697987	Screw (Rotating Screen)	363	19203	Flywheel Puller
75	690582	Washer (Flywheel)	383	89838	Wrench-Spark Plug
78	691003	Screw (Flywheel Guard)			RPM Settings:
93	690602	Ø Bushing-Throttle Shaft			Low Speed: 1900-2100
94	498030	Kit-Idle Mixture			High Speed: 3000-3200
95	691636	Screw (Throttle Valve)			
98	495800	Kit-Idle Speed			
104	690525	Ø Pin-Float Hinge			
105	231855	Ø Valve-Float Needle			
106	690577	Ø Seat-Intake			

- Included in Engine Gasket Set, Key. No. 358
- Ø Included in Carburetor Overhaul Kit, Key. No. 121
- ‡ Included in Carburetor Gasket Set, Key. No. 977
- + Included in Valve Gasket Set, Key. No. 1095

REPAIR PARTS

TRACTOR- -MODEL NO. 917.277180

BRIGGS & STRATTON ENGINE - - MODEL NUMBER 282H07, TYPE NUMBER 0239-E1

KEY NO.	PART NO.	DESCRIPTION	KEY NO.	PART NO.	DESCRIPTION
404	691691	Washer (Governor Crank)	868	690968	*+ Seal-Valve
431	697122	Elbow-Intake	876	495877	Kit-Pinion Spring
445	698083	Filter-Air Cleaner Cartridge	877	393456	Wire-Connector/Alternator
462	691261	Washer (Starter Cable)	896	691641	Pin-Drive Retainer
474	696459	Alternator	914	690960	Screw (Rocker Cover)
503	691532	Strap-Starter	947	694393	Solenoid-Fuel
505	691251	Nut (Governor Control Lever)	950	691657	Screw (Float Bowl)
510	693699	Drive-Starter	967	697015	Filter-Pre Cleaner
510A	497606	Drive-Starter	968	698403	Cover-Air Cleaner
513	692024	Clutch-Drive	975	495933	Bowl-Float
523	697086	Dipstick	977	690192	Gasket Set-Carburetor
524	691032	• Seal-Dipstick Tube	987	691326	Ø Seal-Throttle Shaft
525	697184	Tube-Dipstick	1005	697853	Fan-Flywheel
544	692034	Starter-Armature	1019	697143	Kit-Label
544A	390837	Starter-Armature	1022	272475	*+ Gasket-Rocker Cover
552	697144	Bushing-Governor Crank	1023	692492	Cover-Rocker Arm
559	697561	Screw (Remote Choke)	1026	692003	Rod-Push (Intake)
559A	693675	Screw (Remote Choke)	-- --	692011	Rod-Push (Exhaust)
562	691119	Bolt (Governor Control Lever)	1029	691751	Arm-Rocker
579	691029	Nut (Starter Cable)	1034	690822	Guide-Push Rod
584	697112	Cover-Breather Passage	1036	695700	Label-Emission
601	95162	Clamp-Hose	1040	698368	Plate-Trim
614	691620	Pin-Cotter	1044	691658	Screw (Flywheel)
616	692012	Crank-Governor	1051	691265	Ring-Retaining
617	692138	Ø • Seal-O Ring (Intake Manifold)	1058	275038	Owner's Manual
634	690801	Ø Spring/Seal Assembly (Manual Choke)	1059	698516	Kit-Screw/Washer
634A	690802	Ø Spring/Seal Assembly (Choke A Matic)	1070	690372	Screw (Flywheel Fan)
635	691909	Boot-Spark Plug	1083	691626	Nut (Starter Terminal)
643	698401	Retainer-Air Filter	1083A	690958	Nut (Starter Terminal)
654	690958	Nut (Carburetor)	1090	691293	Retainer-Brush
691	692407	• Seal-Governor Shaft	1091	691333	Cap-Limiter
697	690372	Screw (Drive Cap)	1095	691581	Gasket Set-Valve
718	690959	Pin-Locating	1119	691183	Screw (Alternator)
729	691224	Clip-Wire	1263	697124	Reed-Breather
741	697128	Gear-Timing	1264	697104	Screw (Breather Reed)
757	697607	Link-Counterweight	1265	697125	Support-Blower Housing
758	697134	Counterweight	1266	691917	*Ø Seal-O Ring (Intake Elbow)
759	697392	Pin-Counterweight	1266A	697123	Ø Seal-O Ring(Intake Elbow)
783	693713	Gear-Pinion	1267	697575	Latch-Blower Housing
783A	693059	Gear-Pinion	1270	697156	Plug-AVS Counterweight
789	698329	Harness-Wiring	1279	690960	Screw (Blower Housing Support)
797	693167	Nut (Brush Retainer)			RPM Settings:
801	691283	Cap-Drive			Low Speed: 1900-2100
801A	394856	Cap-Drive			High Speed: 3000-3200
802	691286	Cap-End	•		Included in Engine Gasket Set, Key. No. 358
802A	395537	Cap-End	Ø		Included in Carburetor Overhaul Kit, Key. No. 121
803	693757	Housing-Starter	±		Included in Carburetor Gasket Set, Key. No. 977
803A	398159	Housing-Starter	+		Included in Valve Gasket Set, Key. No. 1095
830	691095	Stud (Rocker Arm)			
842	691031	• Seal-O Ring (Dipstick Tube)			
847	697611	Dipstick/Tube Assembly			
851	692424	Terminal-Spark Plug			

LIMITED WARRANTY ON CRAFTSMAN RIDING EQUIPMENT

For two (2) years from the date of purchase, if this Craftsman Riding Equipment is maintained, lubricated and tuned up according to the instructions in the owner's manual, Sears will repair or replace free of charge any parts that are found to be defective in material or workmanship according to the guidelines of coverage listed below. Sears will also provide free labor for these applicable warranted parts for the two full years. During the first 30 days of purchase, there will be no charges to service the product at your home for issues covered by this warranty. (See exclusions below). For your convenience, IN HOME warranty service will still be available after the first 30 days of purchase, but a trip charge will apply. This charge will be waived if the Craftsman product is dropped off at an authorized Sears location. For the nearest authorized Sears location, please call 1-800-4-MY-HOME®. This warranty applies only while this product is within the United States.

This Warranty does not cover:

- Expendable items which become worn during normal use, including but not limited to blades, spark plugs, air cleaners, belts, and oil filters.
- Standard Maintenance Servicing, oil changes, or tune-ups
- Tire replacement or repair caused by punctures from outside objects, such as nails, thorns, stumps, or glass.
- Repairs necessary because of operator abuse, including but not limited to, damage caused by towing objects beyond the capability of the riding equipment, impacting objects that bend the frame or crankshaft, or over-speeding the engine.
- Repairs necessary because of operator negligence, including but not limited to, electrical and mechanical damage caused by improper storage, failure to use the proper grade and amount of engine oil, failure to keep the deck clear of flammable debris, or failure to maintain the equipment according to the instructions contained in the owner's manual.
- Engine (fuel system) cleaning or repairs caused by fuel determined to be contaminated or oxidized (stale). In general, fuel should be used within 30 days of its purchase date.
- Normal deterioration and wear of the exterior finishes, or product label replacement.
- Riding equipment used for commercial or rental purposes.

LIMITED WARRANTY ON BATTERY

For ninety (90) days from date of purchase, if any battery included with this riding equipment proves defective in material or workmanship and our testing determines the battery will not hold a charge, Sears will replace the battery at no charge. During the first 30 days of purchase, there will be no charges to replace the battery at your HOME. After the first 30 days, for your convenience, IN-HOME warranty service will still be available but a trip charge will apply. This charge will be waived if the Craftsman product is dropped off at an authorized Sears location. For the nearest authorized Sears location, please call 1-800-4-MY-HOME®.

This battery warranty applies only while this product is within the United States.

This warranty gives you specific legal rights, and you may also have other rights, which vary, from state to state.

Sears, Roebuck and Co., Dept. 817WA, Hoffman Estates, IL 60179

CRAFTSMAN®