

REPAIR PARTS MANUAL
MODEL NO. 277200
Lawn Tractor



HOW TO USE THIS MANUAL

This manual is designed to provide the customer with a means to identify the parts on his/her tractor when ordering repair parts. The illustrations may or may not represent the actual assemblies; therefore, it is not recommended to use this manual as a guide to assemble or disassemble the tractor. Some hardware and parts are drawn larger in order to more readily identify them.

Each tractor has its own model number.

The model number for your tractor can be found on the fender under the seat.

When ordering parts, always give the following information:

- Product - "Tractor"
- Model Number - "277200"
- Part Number
- Part Description

TABLE OF CONTENTS

SCHEMATIC	3
ELECTRICAL.....	4-5
CHASSIS.....	6-7
DRIVE.....	8-9
STEERING	10-11
ENGINE.....	12-13
SEAT	14
DECALS.....	15
MOWER LIFT	16-17
MOWER DECK	18-19
TRANSAXLE.....	20-21
ENGINE BREAKDOWN.....	22-27
WARRANTY	28

TRACTOR- -MODEL NO. 917. 277200

SCHEMATIC

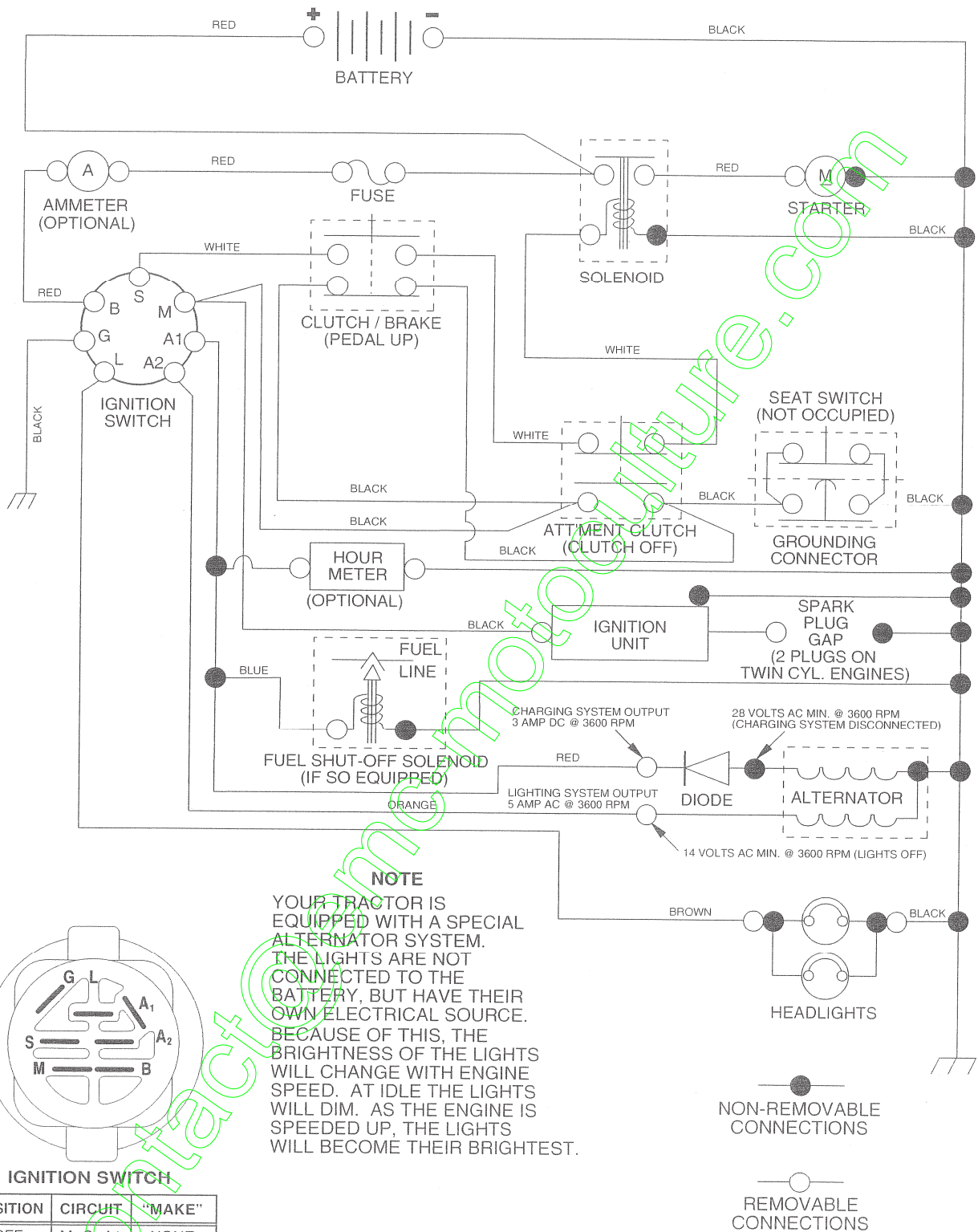

REPAIR PARTS

TRACTOR- -MODEL NO. 917. 277200

ELECTRICAL

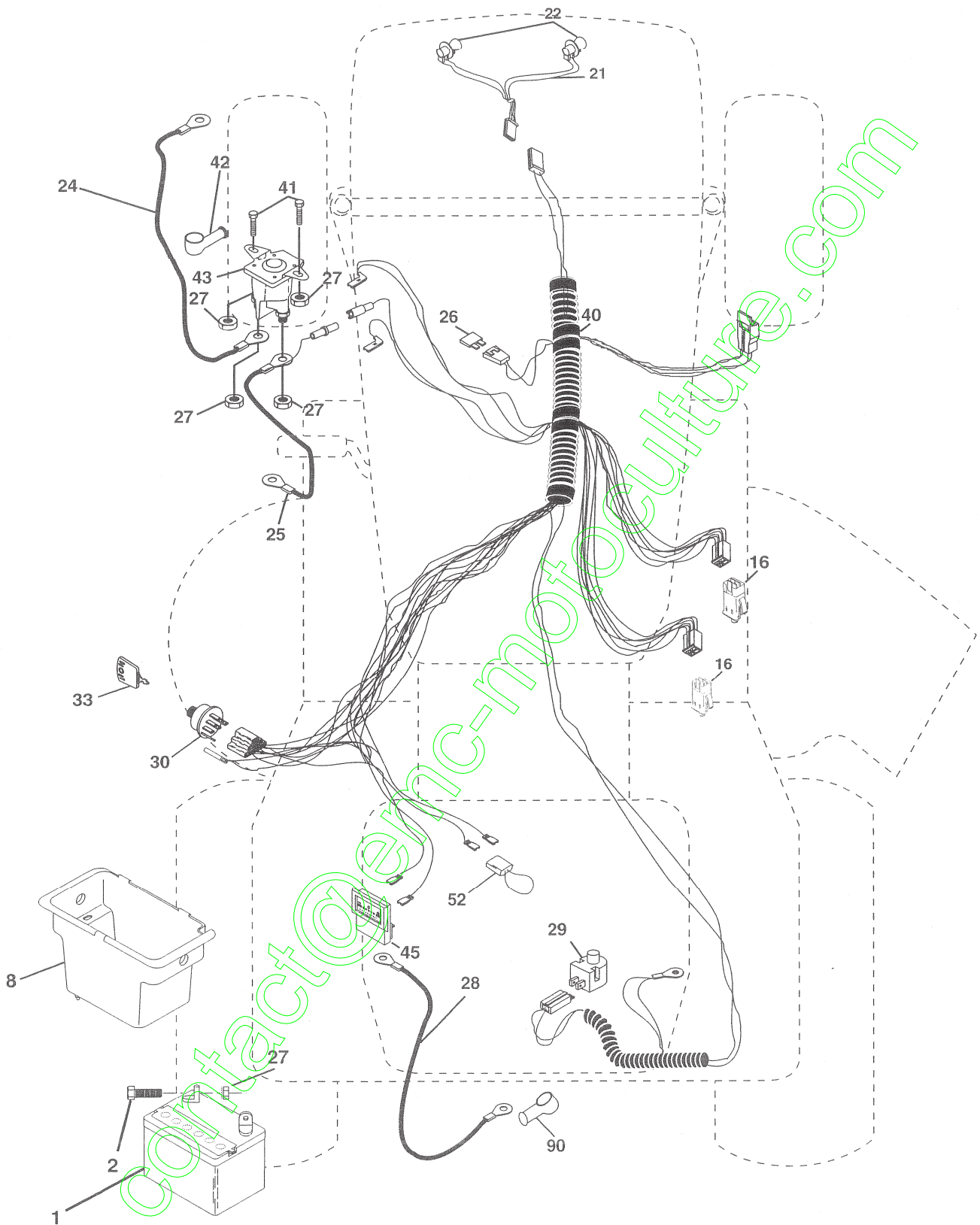

REPAIR PARTS

TRACTOR- -MODEL NO. 917. 277200

ELECTRICAL

KEY NO.	PART NO.	DESCRIPTION
1	163465	Battery
2	74760412	Bolt Hex Hd 1/4-20unc x 3/4
8	176689	Box Battery Fender
16	176138	Switch, Interlock
21	175688	Harness Asm Light W/4152j
22	4152J	Bulb Light #1156
24	4799J	Cable Battery 6 Ga 11" red
25	146147	Cable Battery 6 Ga w/16 wire red
26	175158	Fuse 20 AMP
27	73510400	Nut, Keps Hex 1/4-20 UNC
28	4207J	Cable Ground 6 Ga 12" black
29	121305X	Switch Plunger Nc Gray
30	175566	Switch Ign
33	140403	Key Ign Molded Craftsman
40	179720	Harness Ign
41	71110408	Bolt Blk. Fin Hex 1/4-20 Unc x 1/2
42	131563	Cover Terminal Red
43	178861	Solenoid
45	121433X	Ammeter Rectangular 6 Amp
52	141940	Protection Wire Loop
90	180449	Cover Terminal Battery

NOTE: All component dimensions give in U.S. inches
1 inch = 25.4 mm

REPAIR PARTS

TRACTOR- -MODEL NO. 917. 277200

CHASSIS AND ENCLOSURES

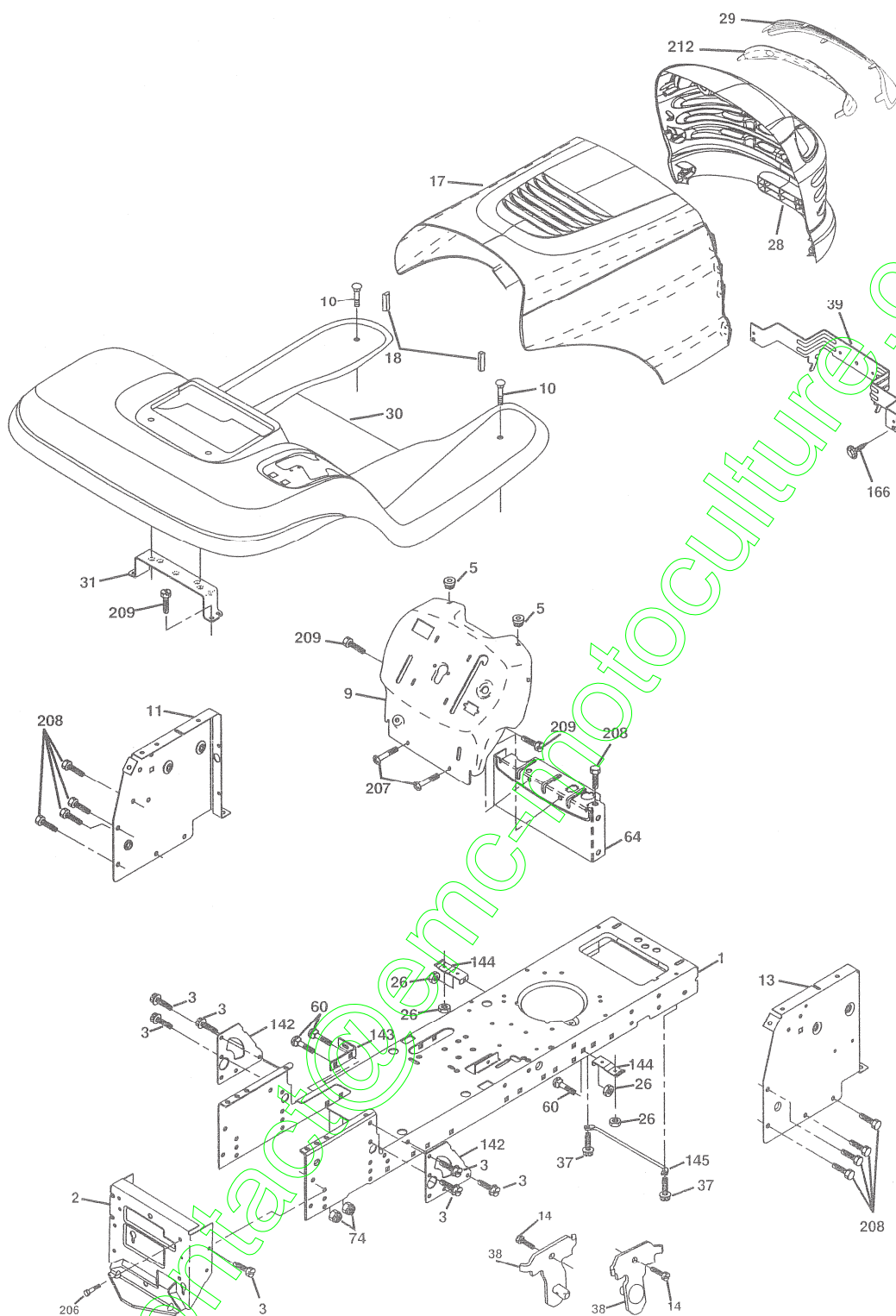

chassis-Laser -lt.stlt_27

REPAIR PARTS

TRACTOR- -MODEL NO. 917. 277200

CHASSIS AND ENCLOSURES

KEY NO.	PART NO.	DESCRIPTION
1	174619	Chassis
2	176554	Drawbar
3	17060612	Screw 3/8-16 x 3/4
5	155272	Bumper Hood/Dash
9	168337X014	Dash.
10	STD533710	Bolt, Carriage 3/8-16 x 1
11	174996	Panel, Dash, L.H.
13	172105X010	Panel, Asm. SLKSCR Dash R.H.
14	17490608	Screw Thdrol 3/8-16 x 1/2
17	185682X558	Hood Assembly
18	184921	Bumper Hood
26	STD541437	Nut, Lock Hex W/Ins. 3/8-16 UNC
28	175049	Grille w/Lens Asm.
29	174332X599	Lens, Grille
30	174738X558	Fender
31	139976	Bracket, Fender Support
37	17490508	Screw Thdrol 5/16-18 x 1/2 TYT
38	175710	Bracket Asm Pivot
39	174714	Bracket Pivot Laser
60	STD533707	Bolt Rdhd Sqnk 3/8-16 UNC x 3/4
64	154798	Dash Lower STLT
74	STD541437	Nut, Crownlock 3/8-16 UNC
142	175702	Plate Reinforcement STLT
143	154966	Bracket Swaybar Chassis
144	175582	Bracket Pnt Footrest STLT
145	156524	Rod Pivot Chassis/Hood
166	171875	Screw HWHD Hi-Lo #13-16 x 3/4
206	170165	Bolt Shoulder 5/16-18 TT
207	17670508	Screw Thdrol 5/8-18 x 1/2
208	17670608	Screw Thdrol 3/8-16 x 1/2
209	17000612	Screw Hex Wsh Thdr 3/8-16 x 3/4
212	175143	Insert Lens Reflective
	5479J	Plug, Button

NOTE: All component dimensions give in U.S. inches
1 inch = 25.4 mm

REPAIR PARTS

TRACTOR- -MODEL NO. 917. 277200

GROUND DRIVE

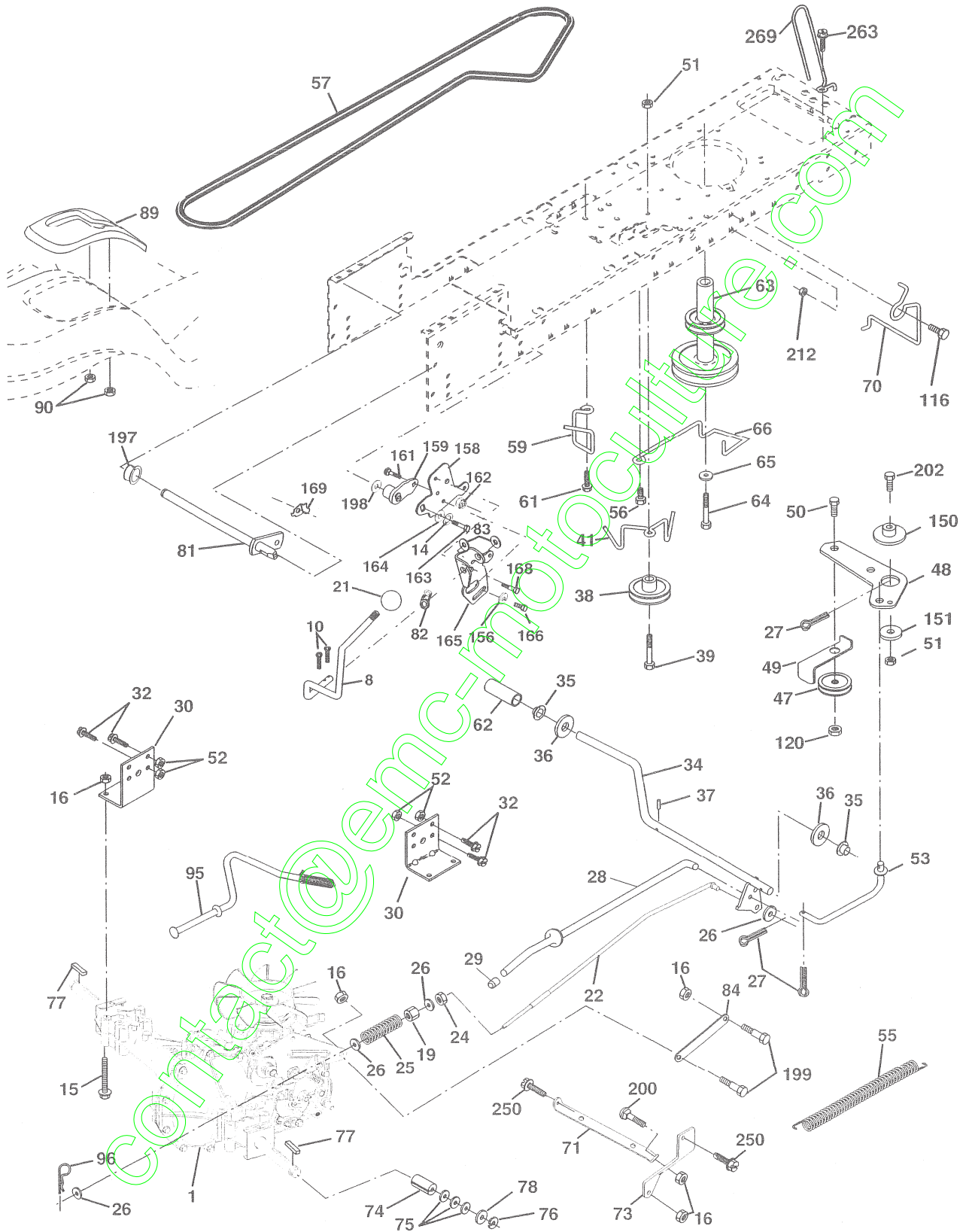

REPAIR PARTS

TRACTOR- -MODEL NO. 917. 277200

GROUND DRIVE

KEY NO.	PART NO.	DESCRIPTION	KEY NO.	PART NO.	DESCRIPTION
1	-----	Transmission (See Breakdown) Hydro Gear Model 322-0510	71	169183	Strap, Torque, Lh
8	165866	Rod, Shift	73	169182	Strap, Torque, Rh
10	STD561210	Pin, Cotter 1/8 x 1	74	137057	Spacer, Axle
14	STD551125	Washer Lock 1/4	75	121749X	Washer 25/32 x 1-1/4 x 16 Ga.
15	74490544	Bolt Hex Flghd 5/16-18 Gr. 5	76	12000001	Ring, E
16	73800500	Nut, Lock Hex w/Ins 5/16-18 UNC	77	123583X	Key, Square
19	73800600	Nut Lock Hex w/Ins 3/8-16	78	121748X	Washer 25/32 x 1-5/8 x 16 Ga.
21	130564	Knob	81	165596	Shaft Asm Cross
22	169498	Rod, Brake	82	165711	Spring, Torsion
24	73350600	Nut	83	19171216	Washer 17/32 x 3/4 x 16 Ga.
25	106888X	Spring, Rod, Brake	84	169843	Link Transaxle
26	19131316	Washer 13/32 x 13/16 x 16 Ga.	89	164890X428	Console, Shift
27	STD561210	Pin, Cotter 1/8 x 3/4	90	124346X	Nut Self-Thd Wshd 1/4
28	175765	Rod, Parking Brake	95	170201	Control Asm Bypass Hydro
29	71673	Cap, Parking Brake	96	STD624003	Spring, Retainer 1"
30	174973	Bracket, Transmission	103	73940800	Nut, Hex Jam Toplock 1/2-20 UNF
32	74760512	Bolt Hex 5/16-18 UNC x 3/4	116	72140608	Bolt Rdhd Sq Neck 3/8-16 x 1
34	175578	Shaft, Foot Pedal	120	73900600	Nut Lock Flg 3/8-16
35	120183X	Bearing, Nylon	150	175456	Spacer Retainer
36	19211616	Washer	151	19133210	Washer 13/32 x 2 x 10
37	1572H	Pin, Roll	156	166002	Washer 5/16 x 1.0 x 1.25
38	179114	Pulley, Composite	158	165589	Bracket Shift Mount
39	74760648	Bolt	159	183900	Hub Tapered Flange Shift
41	175556	Keeper, Belt, Idler	161	72140406	Bolt Rdhd Sqnk 1/4-20 x 3/4 Gr. 5
47	127783	Pulley, Idler, V-Belt	162	73680400	Nut Crownlock 1/4-20 Unc
48	154407	Bellcrank Clutch Grnd Drustl	163	74780416	Bolt Hex Fin 1/4-20 x 1
49	123205X	Retainer, Belt	164	19091010	Washer 5/8 x .281 x 10 Ga.
50	72110612	Bolt Carr Sh. 3/8-16 x 1-1/2 Gr. 5	165	165623	Bracket Pivot Lever
51	STD541437	Nut	166	166880	Screw 5/16 x 1.0 x .125
52	STD541431	Nut Crownlock 5/16-18	168	165492	Bolt Shoulder 5/16-18 x .561
53	105710X	Link, Clutch	169	165580	Plate Fastener Cross Shaft
55	105709X	Spring, Return, Clutch	197	169613	Nyliner Snap-In
56	17060620	Screw 3/8-16 x 1-1/4	198	169593	Washer Nyliner
57	140294	V-Belt, Drive	199	169612	Bolt Shoulder 5/16-18 Unc
59	169691	Keeper, Belt, Center	200	72140508	Bolt RdHd Sqnk 5/16-18 Unc x 1
61	17120614	Screw 3/8-16 x .875	202	72110614	Bolt 3/8-16 x 1-3/4 Gr. 5
62	8883R	Cover, Pedal	205	19171616	Washer 17/32 x 1 x 16 Ga.
63	180219	Pulley, Engine	212	145212	Nut Hex Flange Lock
64	173937	Bolt Hex 7/16-20 x 4 x Gr. 5 -	250	17060612	Screw 3/8-16 x 3/4
65	10040700	Washer	263	17000612	Screw Hex Wsh Thdr 3/8-16 x 3/4
66	154778	Keeper, Belt Engine Hydro	269	182402	Guard Muffler RH
70	180218	Guide, Belt, Mower Drive RH			

NOTE: All component dimensions given in U.S. inches
1 inch = 25.4 mm

REPAIR PARTS

TRACTOR- -MODEL NO. 917. 277200

STEERING ASSEMBLY

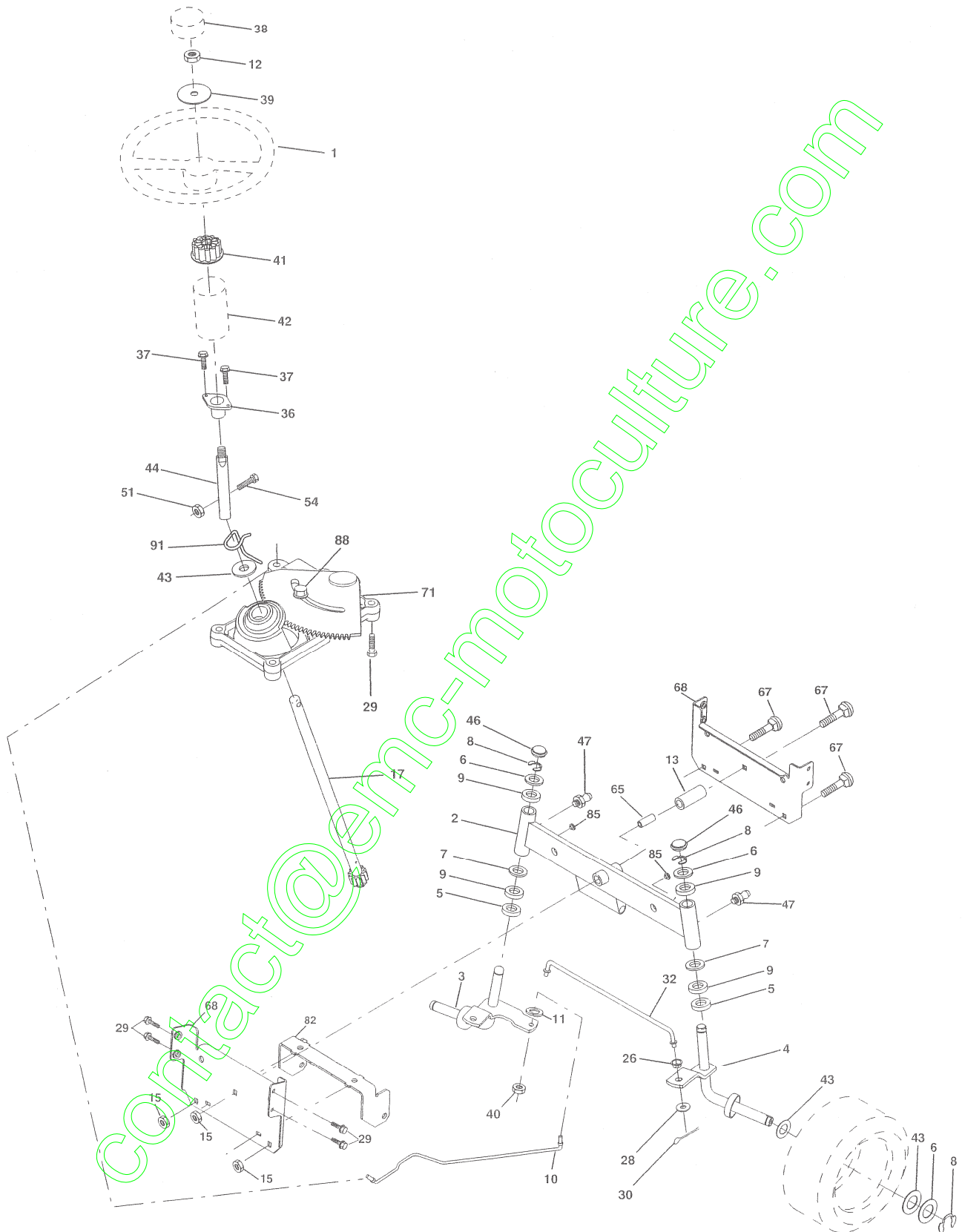

REPAIR PARTS

TRACTOR- -MODEL NO. 917. 277200

STEERING ASSEMBLY

KEY NO.	PART NO.	DESCRIPTION
1	139768	Steering Wheel
2	175131	Front Axle Assembly
3	169840	Spindle Assembly, L.H.
4	169839	Spindle Assembly, R.H.
5	6266H	Bearing, Race, Thrust, Hardened
6	121748X	Washer 25/32 x 1-5/8 x 16 Gauge
7	19272016	Washer 27/32 x 1-1/4 x 16 Gauge
8	12000029	Ring, Klip
9	3366R	Bearing, Steering Column
10	175121	Link, Drag
11	STD551137	Washer, Lock
12	73940800	Nut Hex Jam Toplock 1/2-20 UNF
13	136518	Spacer, Bearing, Front Axle
15	145212	Nut Lock Hex Flange
17	180641	Shaft Assembly, Steering
26	126847X	Bushing, Link, Drag
28	19131416	Washer 13/32 x 7/8 x 16 Gauge
29	17060612	Screw 3/8-16 x 3/4
30	STD561210	Pin, Cotter
32	130465	Rod, Tie
36	155099	Bushing, Steering
37	152927	Screw TT #10-32 x 5 x 3/8 Flange
38	139769	Cap Wheel Steer OPP Blk
39	19183812	Washer 9/16 ID x 2-3/8 OD 12 Ga.
40	STD541537	Nut Lock Center 3/8-24 UNF
41	100711L	Adaptor, Steering Wheel
42	145054X428	Boot, Steering Dash P/L Mtl Blk
43	121749X	Washer 25/32 x 1-1/4 x 16 Gauge
44	180640	Extension Steering
46	121232X	Cap, Spindle
47	183226	Fitting, Grease
51	73540400	Nut Crownlock 1/4-28
54	71130420	Bolt Hex 1/4-28 UNF x 1-1/4 Gr. 8
65	160367	Spacer Brace Axle
67	72140618	Bolt Rdhd Sq 3/8-16 x 2-1/4
68	169827	Brace Axle
71	175146	Steering Asm.
82	169835	Bracket Susp Chassis Front
85	133835	Fastener Christmas Tree
88	175118	Bolt Shoulder 7/16-20
91	175553	Clip Steering

NOTE: All component dimensions given in U.S. inches
1 inch = 25.4 mm

REPAIR PARTS

TRACTOR- -MODEL NO. 917. 277200

ENGINE

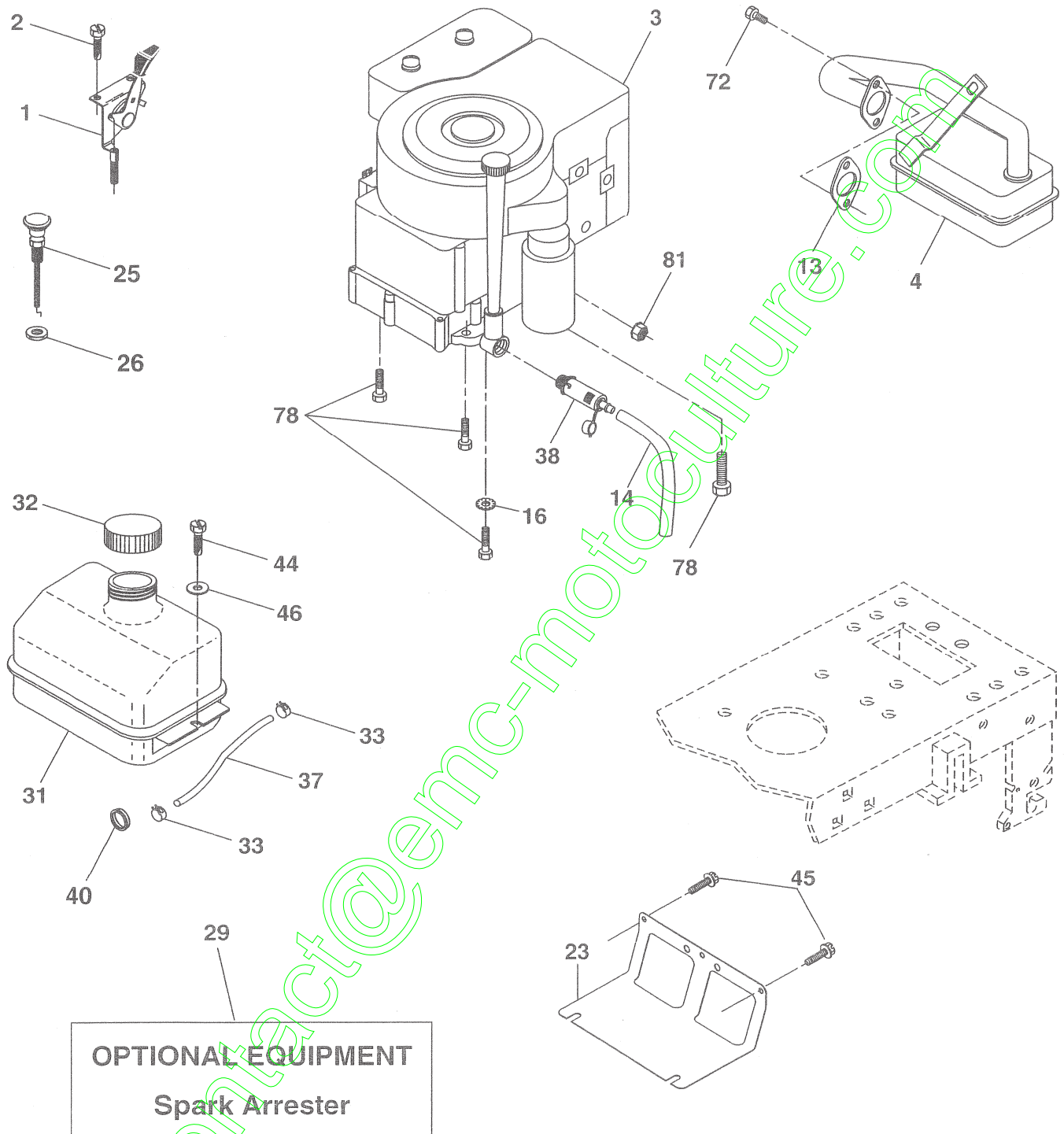

REPAIR PARTS

TRACTOR- -MODEL NO. 917. 277200

ENGINE

KEY NO.	PART NO.	DESCRIPTION
1	170545	Control Throttle/Choke
2	17720408	Screw Hex Thd Cut 1/4-20 x 1/2
3	-----	Engine (See Breakdown) Briggs Model 31C707-0240-E1
4	137352	Muffler Exhaust B&S Lt
13	165291	Gasket 1 313 Id Tin Plated
14	148456	Tube Drain Oil
16	STD551237	Washer Lock Ext Tooth 3/8
23	169837	Shield BRN/DBR Guard
25	180945	Control Choke
26	73920600	Nut Keps 3/8-24 Unf
29	137180	Arrestor Spark
31	184900	Tank Fuel 1 25 Fr
32	140527	Cap Asm Fuel W/sym Vented
33	123487X	Clamp Hose Blk
37	137040	Line Fuel 20"
38	148315	Plug Oil Drain
40	124028X	Bushing Snap Nyl Blk Fuel Line
44	17670412	Screw Hexwsh Thdrol 1/4-20x3/4
45	17000612	Screw Hexwsh Thdr 3/8-16 x 3/4
46	19091416	Washer 9/32 X 7/8 X 16ga
72	183906	Screw Socket Head 5/16-18 x 1
78	17060620	Screw 3/8-16x1-1/4
81	73510400	Nut Keps Hex 1/4-20unc

NOTE: All component dimensions given in U.S. inches
1 inch = 25.4 mm

contact@enginculture.com

REPAIR PARTS

TRACTOR- -MODEL NO. 917. 277200

SEAT ASSEMBLY

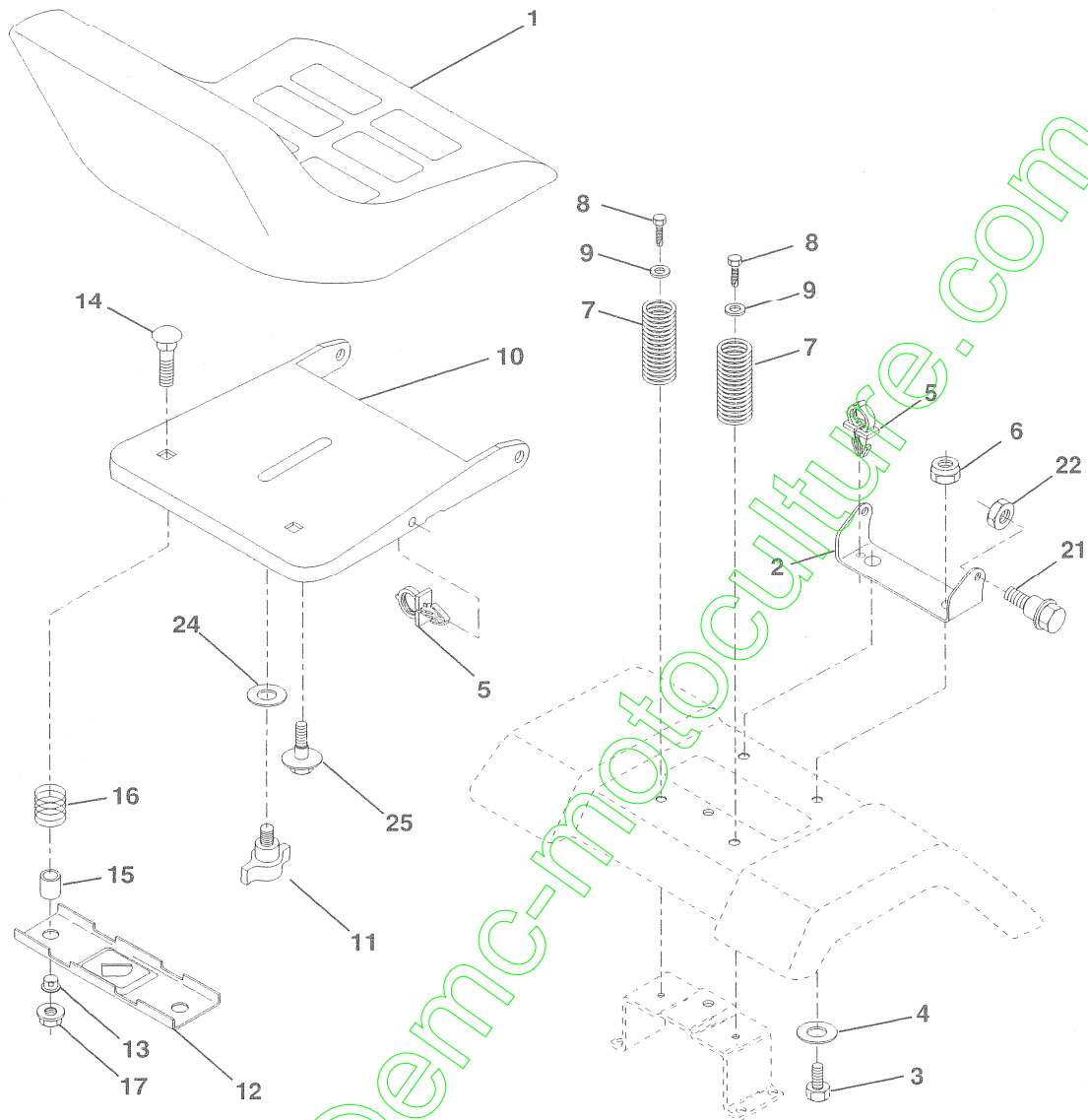

KEY NO.	PART NO.	DESCRIPTION
1	140122	Seat 3350 Blk/blk Craftsman
2	140551	Bracket Pnt Pivot Seat (blk)
3	71110616	Bolt Fin Hex 3/8-16unc X 1
4	19131610	Washer 13/32 X 3/4 X 10 Ga
5	145006	Clip Push In Hinged
6	STD541437	Nut Hex Lock w/Ins 3/8-16 Unc
7	124181X	Spring Seat Cprsn 2 250 Blk Zi
8	17000616	Screw 3/8-16 X 1 -1/2
9	19131614	Washer 13/32 X 1 X 14 Ga
10	182493	Pan Pnt Seat (blk)
11	166369	Knob Seat
12	121246X	Bracket Pnt Mounting Switch

KEY NO.	PART NO.	DESCRIPTION
13	121248X	Bushing Snap Blk Nyl 50 Id
14	72050412	Bolt Rdhd Sht Nk 1/4-20x1-1/2
15	134300	Spacer Split 28 X 96 Zinc
16	121250X	Spring Cprsn 1 27 Blk Pnt
17	123976X	Nut Lock 1/4 Lge Flg Gr 5 Zinc
21	171852	Bolt Shoulder 5/16-18 Unc-2A
22	STD541431	Nut Hex Lock w/Ins 5/16-18
24	19171912	Washer 17/32 X 1-3/16 X 12 Ga
25	127018X	Bolt Shoulder 5/16-18 X 62

NOTE: All component dimensions given in U.S. inches
1 inch = 25.4 mm

REPAIR PARTS

TRACTOR- -MODEL NO. 917. 277200

DECALS

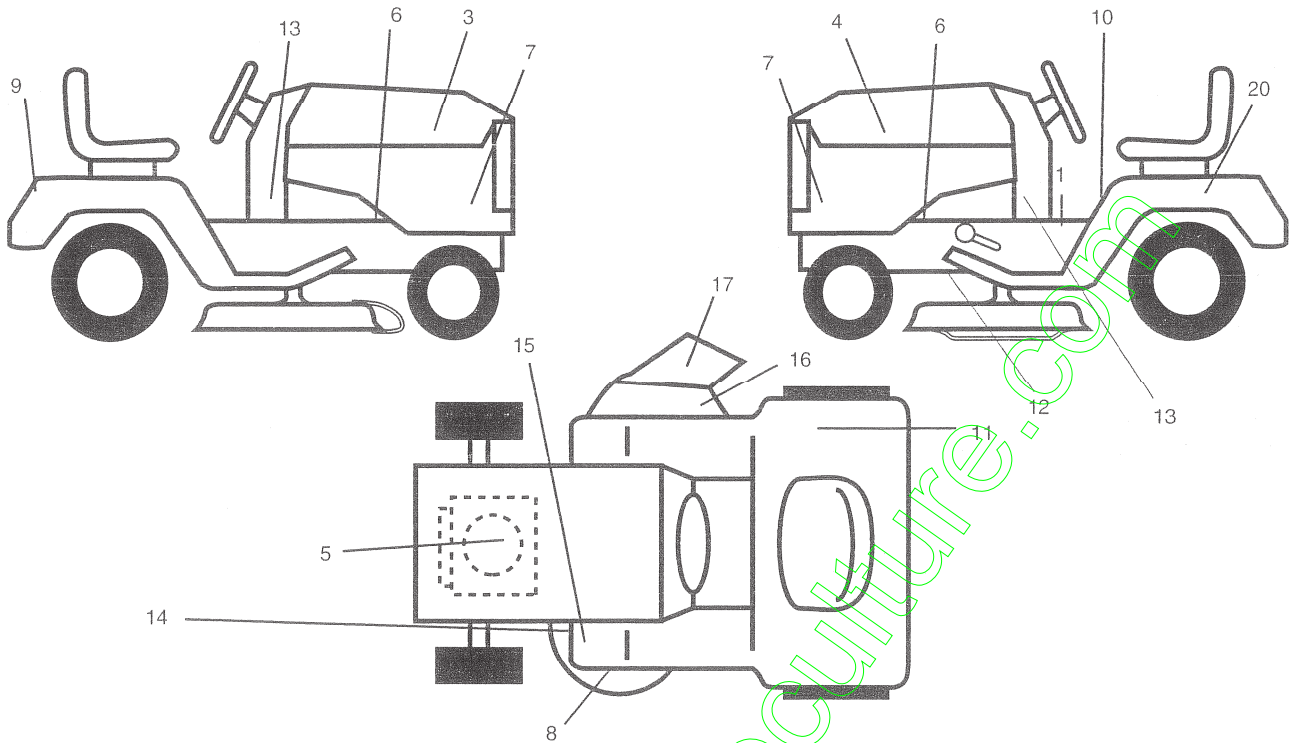

KEY NO.	PART NO.	DESCRIPTION
1	140837	Decal, Brake Parking
3	184728	Decal, Hood Rh
4	184729	Decal, Hood Lh
5	186377	Decal, Hp Engine
6	159736	Decal, Chass Hot Muffler
7	184730	Decal, Hood Side Panel
8	172331	Decal, Mower
9	184899	Decal, Fender Craftsman
10	145498	Decal, Read Owners
11	180432	Decal, 100 DB/CE
12	146046	Decal, V-belt Dr Sch
13	186787	Decal, Dash, Panel
14	160396	Decal, V-belt Schematic

KEY NO.	PART NO.	DESCRIPTION
15	159737	Decal, Brake/Clutch
16	182166	Decal, Internation Cutfinger
17	179128	Decal, Deck "B" 42"
20	145005	Decal, Battery Dngr/Psn Eng
--	169210	Decal, Bypass
--	138311	Decal, Lift Handle
--	165800X428	Pad, Footrest LH STLT
--	165799X428	Pad, Footrest RH STLT
--	162598	Decal, Draw Bar
--	187185	Manual, Operator's (Euro)
--	187186	Manual, Operator's (Scand)
--	187187	Manual, Parts

WHEELS & TIRES

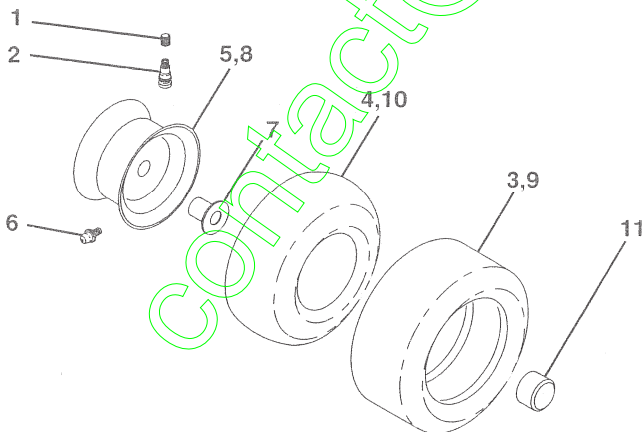

KEY NO.	PART NO.	DESCRIPTION
1	59192	Cap Value Tire
2	65139	Stem Value
3	106222X	Tire F Ts 15 X 6 0 - 6 Service
4	59904	Tube Inner Front #35060
5	106732X624	Rim Asm 6"front White Service
6	278H	Fitting Grease
7	9040H	Bearing Flange
8	106108X624	Rim Asm 8"rear White Service
9	106268X	Tire R Ts 18x9 5-8 Service
10	7152J	Tube Rear 9 5 X 8 Service
11	104757X428	Cap Axle Blk 1 50 X 1 00
--	144334	Sealant, Tire (10 oz. tube)

NOTE: All component dimensions given in U.S. inches
1 inch = 25.4 mm

REPAIR PARTS

TRACTOR- -MODEL NO. 917. 277200

LIFT ASSEMBLY

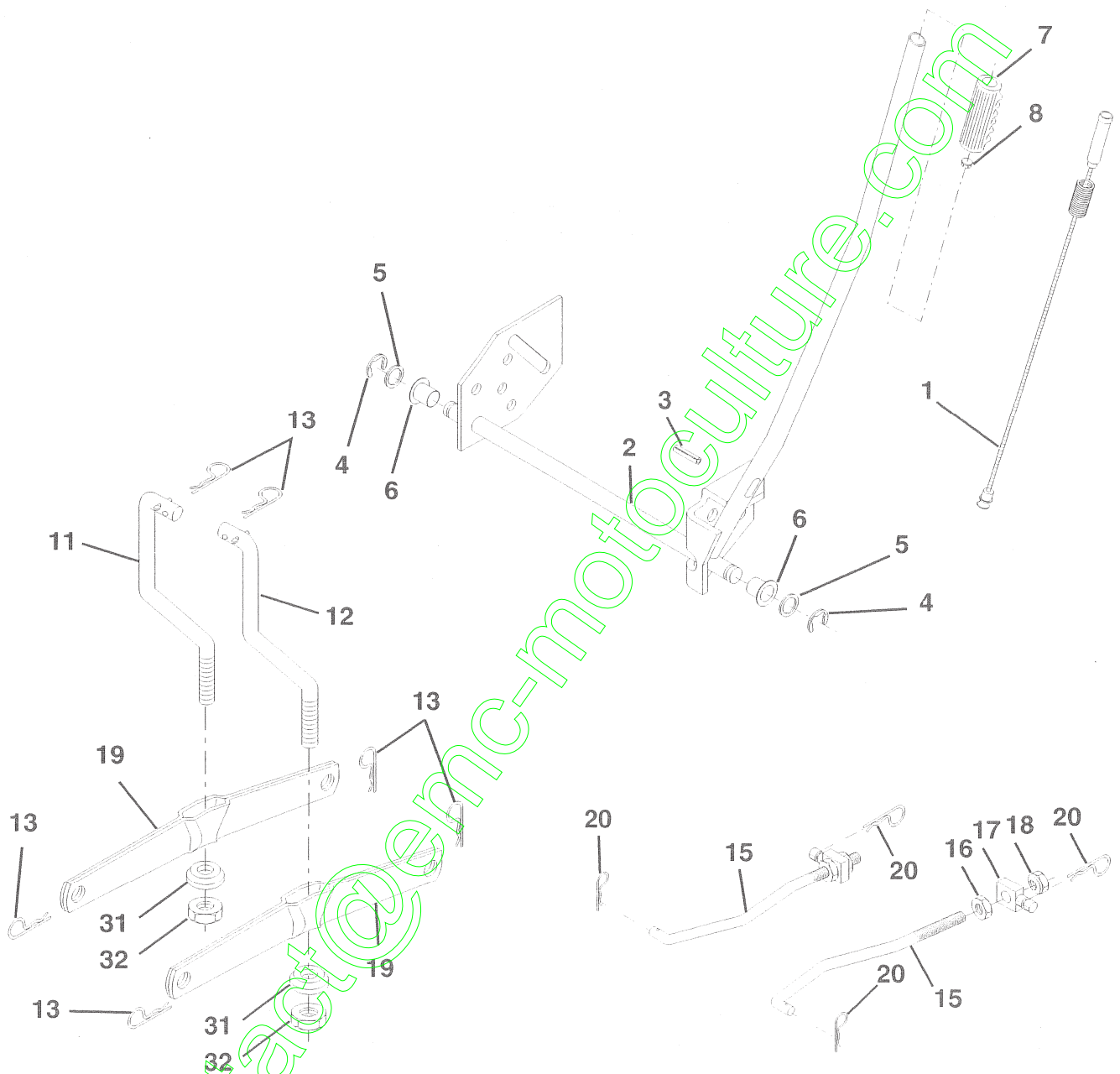

REPAIR PARTS

TRACTOR- -MODEL NO. 917. 277200

LIFT ASSEMBLY

KEY NO.	PART NO.	DESCRIPTION
1	159460	Washer Asm Inner Spring W/Plunger
2	159471	Shaft Asm. Lift RH
3	105767X	Pin Groove
4	12000002	E Ring #5133-62
5	19211621	Washer 21/32 x 1 x 21 Ga.
6	120183X	Bearing Nylon
7	125631X	Grip Handle Fluted
8	122365X	Button Plunger Read
11	139865	Link Asm Lift L.H.
12	139866	Link Asm Lift R.H.
13	STD624008	Retainer Spring
15	173288	Link Front
16	73350800	Nut Jam Hex 1/2-13 Unc
17	175689	Trunnion Blk Zinc
18	73800800	Nut Lockw/wsh 1/2-13 Unc
19	139868	Arm Suspension Mower
20	163552	Retainer Spring
31	169865	Bearing, Pvt. Lift.
32	73540600	Nut Crownlock 3/8-24

NOTE: All component dimensions given in U.S. inches
1 inch = 25.4 mm

REPAIR PARTS

TRACTOR- -MODEL NO. 917. 277200

MOWER DECK

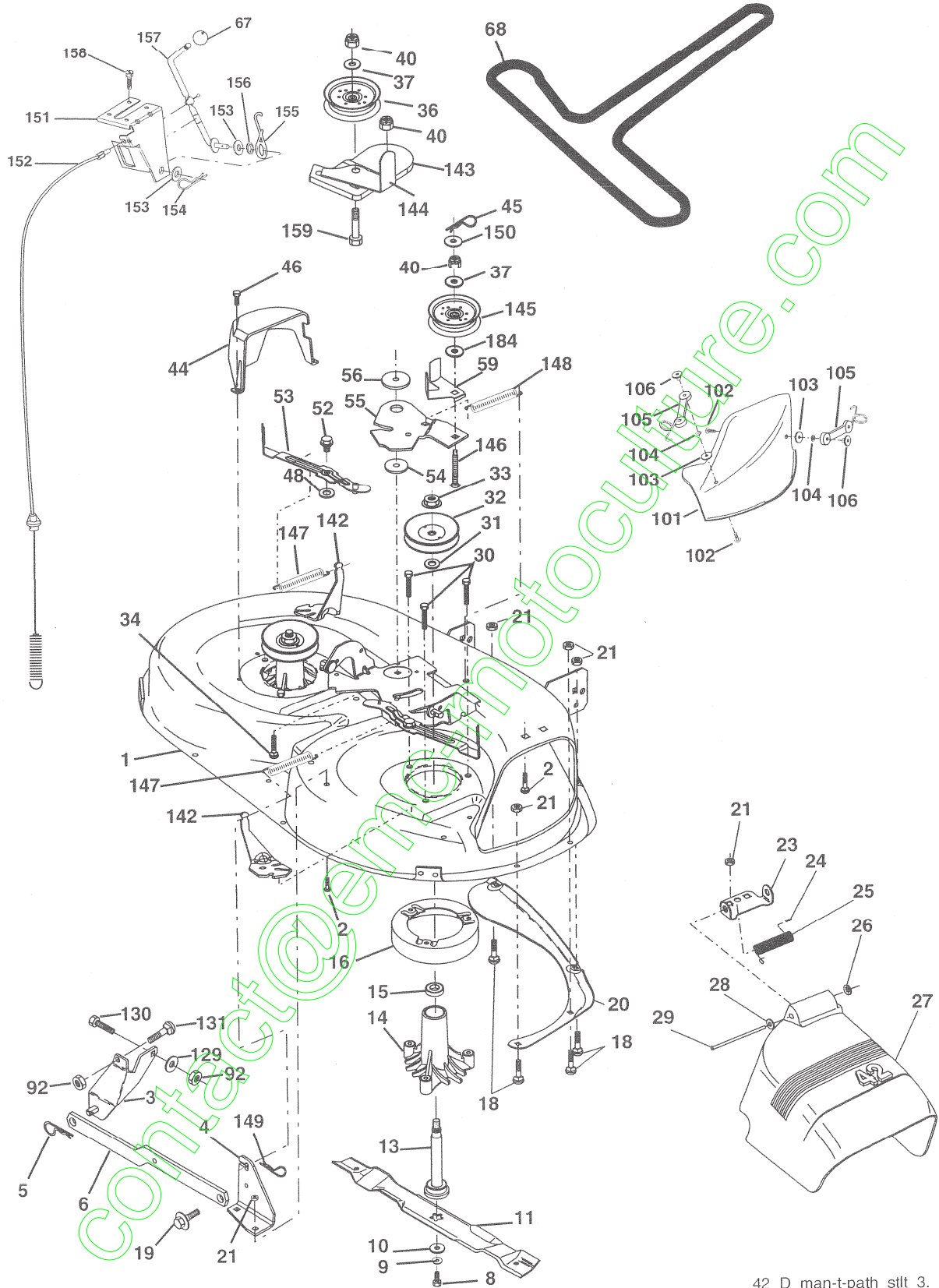

42_D_man-t-path_stlt_3.

REPAIR PARTS

TRACTOR- -MODEL NO. 917. 277200

MOWER DECK

KEY NO.	PART NO.	DESCRIPTION	KEY NO.	PART NO.	DESCRIPTION
1	165892	Mower Deck Assembly, 42"	59	141043	Guard, TUV Idler
2	STD533107	Bolt	67	149846	Knob Custom Oval
3	138017	Bracket Assembly, Sway Bar, Front	68	180215	V-Belt
4	165460	Bracket Sway Bar 38/42" Deck	92	STD541437	Nut
5	STD624008	Retainer Spring	101	136420	Mulcher Cover
6	178024	Bar Sway Deck	102	71081010	Screw
8	850857	Bolt, Hex 3/8-24 x 1.25 Gr. 8	103	19061216	Washer #10
9	STD551137	Washer, Lock	104	STD551110	Washer, Lock
10	140296	Washer, Hardened	105	160793	Latch Assembly, Bagger
11	134149	Blade, Mulching	106	2029J	Nut, Weld
13	137645	Shaft Assembly	129	19131312	Washer 13/32 x 13/16 x 12 Ga.
14	128774	Housing, Mandrel, Vented	130	STD523710	Bolt, Fin Hex 3/8-16 UNC x 1 Gr.5
15	110485X	Bearing, Ball, Mandrel	131	STD533710	Bolt, Rdhd Sqnc 3/8-16UNC x 1
16	174493	Stripper, Mower Deck	142	165890	Arm Spring Brake Mower
18	72140505	Bolt, Carriage 5/16-18 x 5/8	143	157109	Bracket Arm Idler 42"
19	132827	Bolt, Shoulder	144	158634	Keeper Belt 42" Clutch Cable
20	159770	Baffle, Vortex	145	165888	Pulley Idler Flat
21	STD541431	Nut Crownlock 5/16-18 UNC	146	171977	Bolt Carriage Idler
23	177563	Bracket, Deflector	147	179748	Spring Extension
24	105304X	Cap, Sleeve	148	169022	Spring Return Idler
25	123713X	Spring, Torsion, Deflector	149	165898	Retainer Spring Yellow Zinc
26	110452X	Nut, Push	150	19091216	Washer 9/32 x 3/4 x 16 Ga.
27	130968X428	Shield, Deflector	151	169670	Bracket Clutch
28	19111016	Washer 11/32 x 5/8 x 16 Ga.	152	181555	Cable Clutch 42 In
29	131491	Rod, Hinge	153	169674	Washer Flat 3/8" Type B
30	173984	Screw Thdrol	154	169675	Spring Retainer
31	129963	Washer, Spacer	155	169671	Spring Retention Lever
32	153535	Pulley, Mandrel	156	169672	Spacer
33	178342	Nut, Toplock, Flanged	157	169669	Rod Clutch
34	STD533717	Bolt	158	17720408	Screw Hex Thd Cut 1/4-20 x 1/2
36	131494	Pulley, Idler, Flat	159	72140614	Bolt Tdhd Sgn 3/8-16UNC x 1-3/4
37	STD551037	Washer 13/32 x 13/16 x 16 Ga.	184	19131410	Washer 13/32 x 7/8 x 10 Ga.
40	STD541437	Nut Crownlock 3/8-16 UNC	--	130794	Mandrel Assembly (Includes Housing, Shaft, and Shaft Hardware Only - Pulley Not Included)
44	140088	Guard, Mandrel, L.H.	--	181268	Replacement Mower, Complete
45	STD624003	Retainer			
46	137729	Screw, Thd. Roll 1/4-20 x 5/8			
48	133944	Washer, Hardened			
52	139888	Bolt, Shoulder 5/16-18 UNC			
53	184907	Arm Assembly, Pad, Brake			
54	178515	Washer, Hardened			
55	155046	Arm, Idler			
56	165723	Spacer, Retainer			

NOTE: All component dimensions given in U.S.inches
1 inch = 25.4 mm

REPAIR PARTS

TRACTOR- -MODEL NO. 917. 277200

TRANSAXLE - - MODEL NUMBER 322-0510

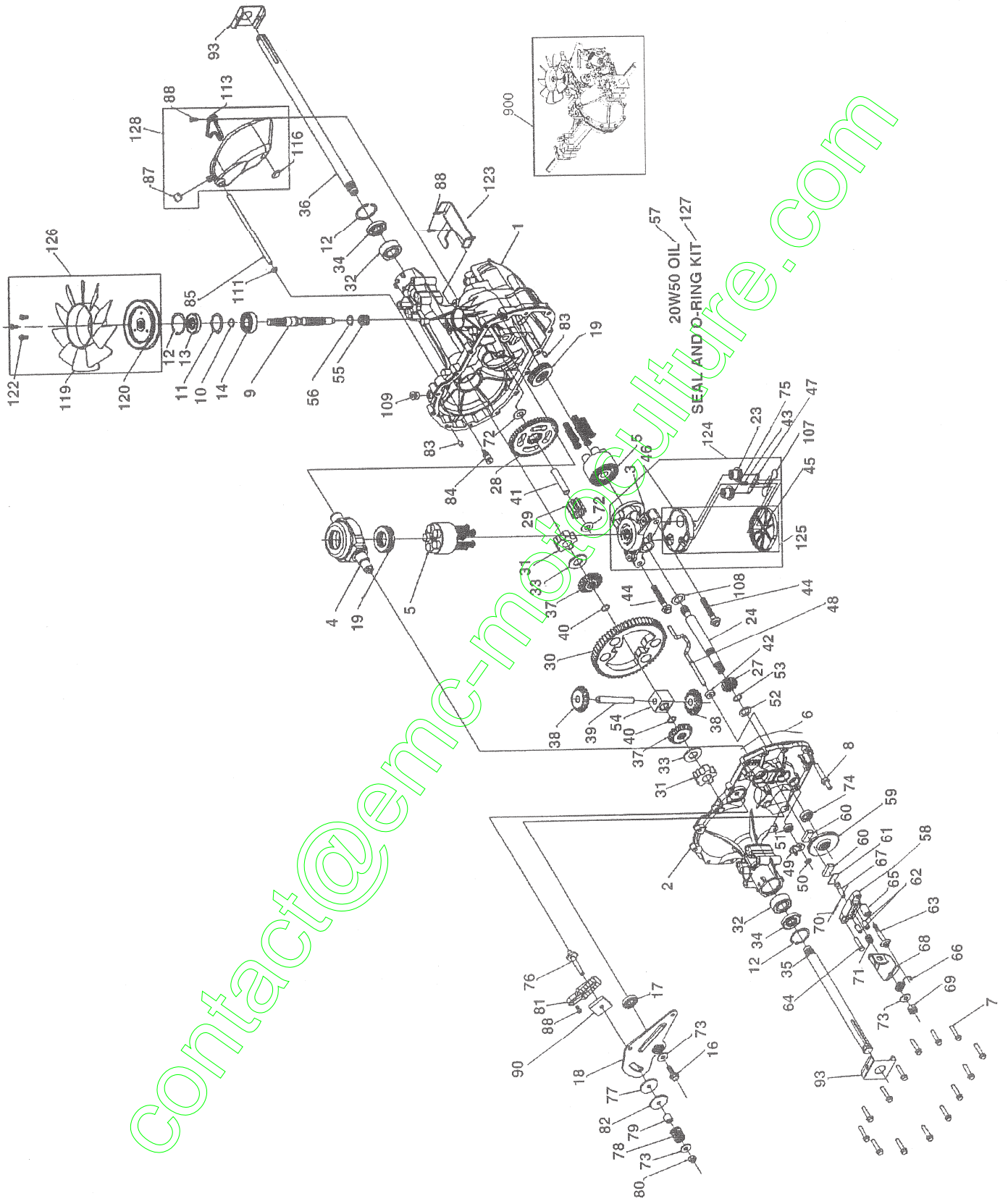

REPAIR PARTS

TRACTOR- -MODEL NO. 917. 277200

TRANSAXLE - - MODEL NUMBER 322-0510

KEY NO.	PART NO.	DESCRIPTION	KEY NO.	PART NO.	DESCRIPTION
1	170351	Main Housing, Assembly	60	142883	Brake Puck
2	170352	Side Housing, Assembly	61	142882	Puck Plate
3	170353	Center Section, Assembly	62	142887	Brake Actuating Pin
4	170354	Swashplate, Trunion Machined	63	170410	HFHCS 1/4-20X2 W/Patch, Special Flange
5	169898	Block - Assembly			
6	170355	Sealant	64	142892	Bolt, 1/4-20 X 1 W/Patch
7	170356	Hex Flange Screw 1/4-20 X 1.25	65	170411	Spacer
8	170357	Stud, 5/16-24 Hex Double End	66	170412	Spring, Brake Arm Bias
9	170358	Shaft, Input	67	170413	SQ. HD. BOLT 5/16-24-Ribbed
10	170359	Ring - Retaining	68	170414	Arm, Brake
11	170360	Spacer	69	170415	Slotted Hex Nut 5/16-24
12	169870	Ring - Retaining	70	170416	Cotter Pin 3/32 X 3/4
13	170361	Seal, Lip .67 X 1.58 X .276	71	170417	Compression Spring Brake Anti-Drage
14	173158	Ball Brg 17MM ID X 40MM OD X 12MM	72	170418	Washer, HT .5 I.D. X 1 O.D. X .032
16	170362	Hex F Llange Head Screw 5/16-24 X 0.75	73	142884	Flat Washer 11/32 I.D. X 7/8 O.D.
17	170363	Lip Seal 18 X 32 X 7	74	170419	Oil Seal .625 X 1.0 X .25
18	170364	Arm, Control	75	170420	Check Plug Assembly, .027, Washer
19	173159	Bearing, 30X52X13 Thrust	76	170421	Stud, 5/16-24 Friction Pack
23	170365	Check Plug Assembly, Washer	77	170422	Puck, .330 X 1.50 X .0975
24	170366	Shaft, Motor1	78	142969	Spring, Helical Comp
27	170367	Gear - Pinion, 13T	79	142980	Spacer
28	170368	10T/48T GEAR	80	150778	Hex Lock Nut 5/16-24 UNJF(Nylon Insert)
29	170369	Gear, 10T Jackshaft			
30	170370	60T Bull Gear	81	170423	Wedge, Friction Pack
31	170371	Sleeve Bearing .75 X 1.575 X .625	82	170424	Clip, Washer .316X1.50X.1046 (Plated)
32	170389	Sleeve Bearing (Outboard).75X1.750X.625	83	161168	Pin, Standard Headless
33	142991	Washer, 3/4 ID X 1-1/2 OD X .13 THK	84	170425	Fitting, 5/16 Sae 5/32 Tube
34	170390	Lip Seal Axle Seal	85	170426	Hose, Expansion Tank
35	170391	Shaft, Axle .75 X 11.39 (Key, R.H.)	87	173160	Cap, Vent
36	170392	Shaft, Axle .75 X 16.99 (Key, L.H.)	88	170429	Bolt, Self Tapping 10-32 X 1/2
37	150792	Miter Gear (SPLINED)	90	170430	Puck, Inner Wedge
38	150793	Miter Gear 15T (0.5 ID)	93	170431	Spring Clip - Housing Thrust
39	150809	Shaft	107	170432	Deflector
40	170393	Ring, Spiral Retaining	108	170433	Washer, Motorshaft .71ID X 1.15OD X .030THK
41	170394	Pin, Jackshaft	109	170434	Plug, Sae #6
42	170395	Magnet, Rling	111	170435	O-ring .07 x .301 I.D.
43	170396	Spring, Bypass	113	170437	Bracket, Support Expansion Tank
44	150797	Hydro mtg Screw 3/8-24 X 2.5 Long	116	170438	Silicon Sponge
45	170397	Filter	119	173161	Fan
46	170398	Base, Filter	120	170440	Pulley
47	170399	Actuator, Bypass	122	173162	#12 T.F. Screw-lindented Hex Washer Head
48	170400	Rod, Bypass Actuator			
49	170401	Arm, Bypass	123	173163	Bracket Belt Keeper
50	170402	Retaining Ring 250 External	124	170444	Center Section-Filter-Bypass Assembly
51	170403	Seal, Lip .741 X .250 X .250 TC	125	170445	Filter Assembly
52	170404	Flat Washer, 5/8 ID X 1.0 OD X .05 THK	126	173164	Fan - Pulley Service Aasembly
53	170405	Retaining Ring	127	170447	Seal - O-ring Kit
54	170406	Bearing, Center Block	128	173165	Kit, Expansion Tank
55	142977	Spring - Helical Compression	900	171613	Transaxle, complete
56	142978	Washer			
57	150798	20W-50 OIL 72.8 oz			
58	170407	Brake Yoke			
59	170408	Rotor, Brake			

NOTE: All component dimensions given in U.S. inches
1 inch = 25.4 mm

REPAIR PARTS

TRACTOR- -MODEL NO. 917. 277200

BRIGGS & STRATTON ENGINE-MODEL NUMBER 31C707, TYPE NUMBER 0240-E1

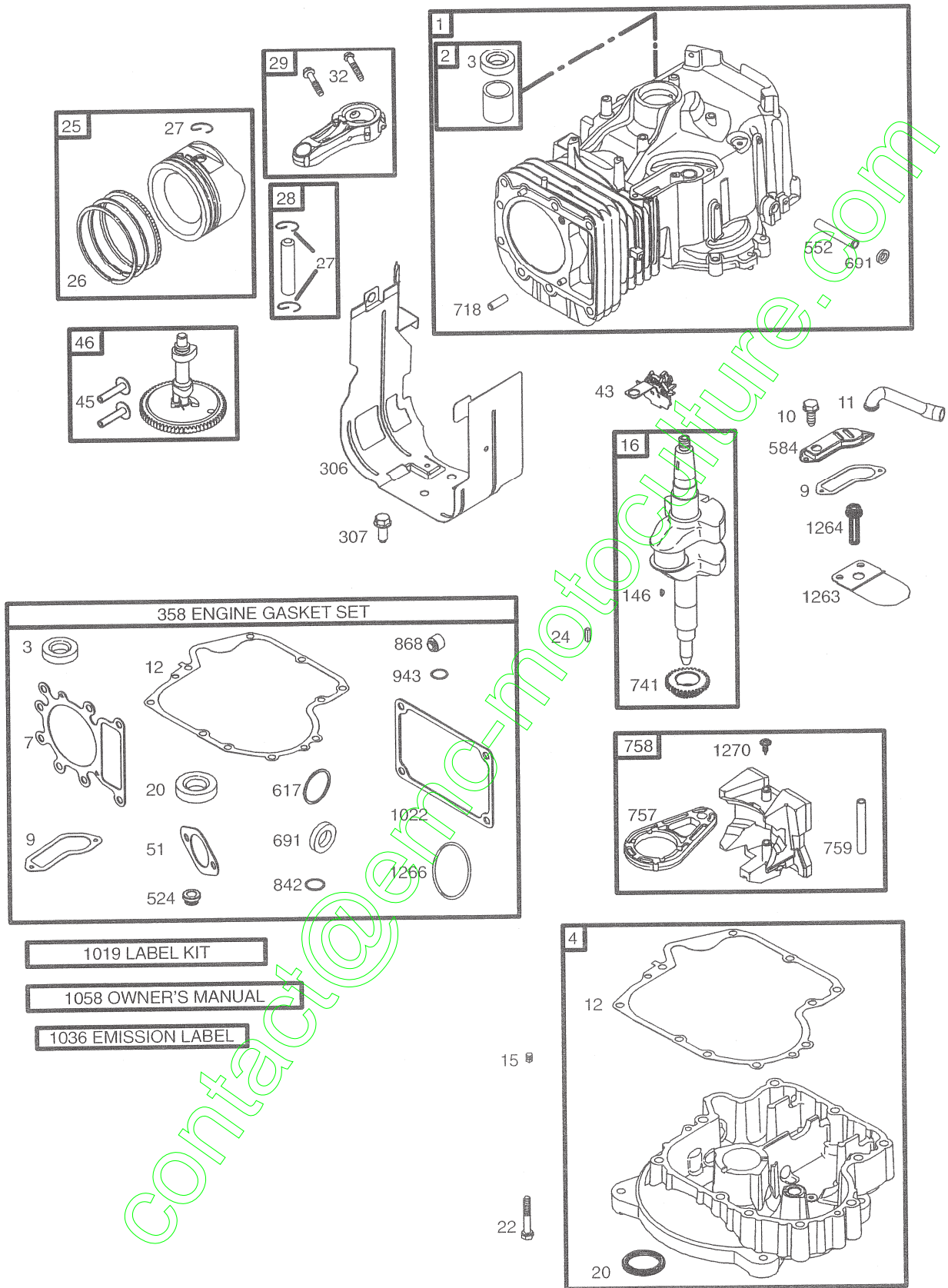

REPAIR PARTS

TRACTOR- -MODEL NO. 917. 277200

BRIGGS & STRATTON ENGINE-MODEL NUMBER 31C707, TYPE NUMBER 0240-E1

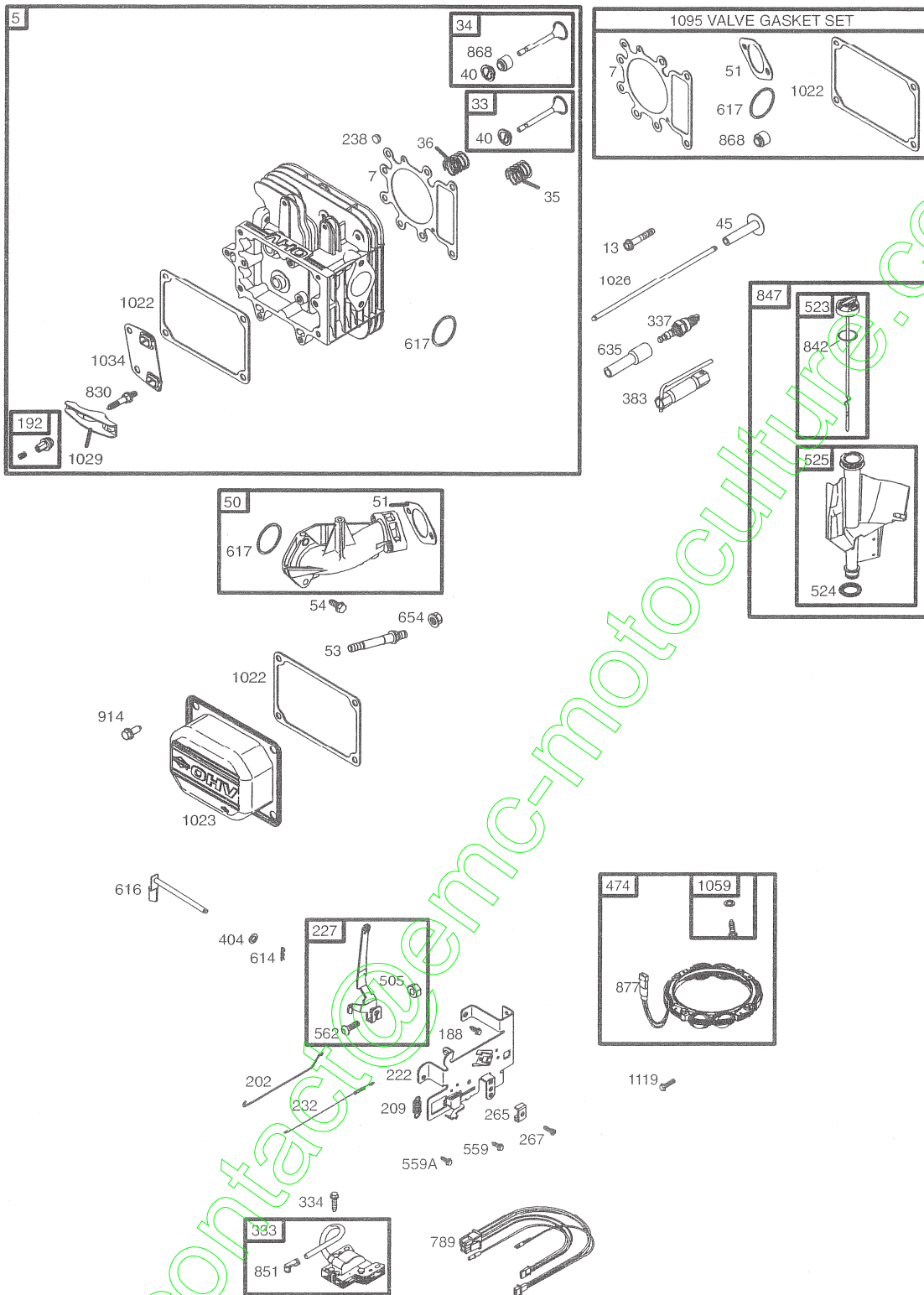

REPAIR PARTS

TRACTOR- -MODEL NO. 917. 277200

BRIGGS & STRATTON ENGINE-MODEL NUMBER 31C707, TYPE NUMBER 0240-E1

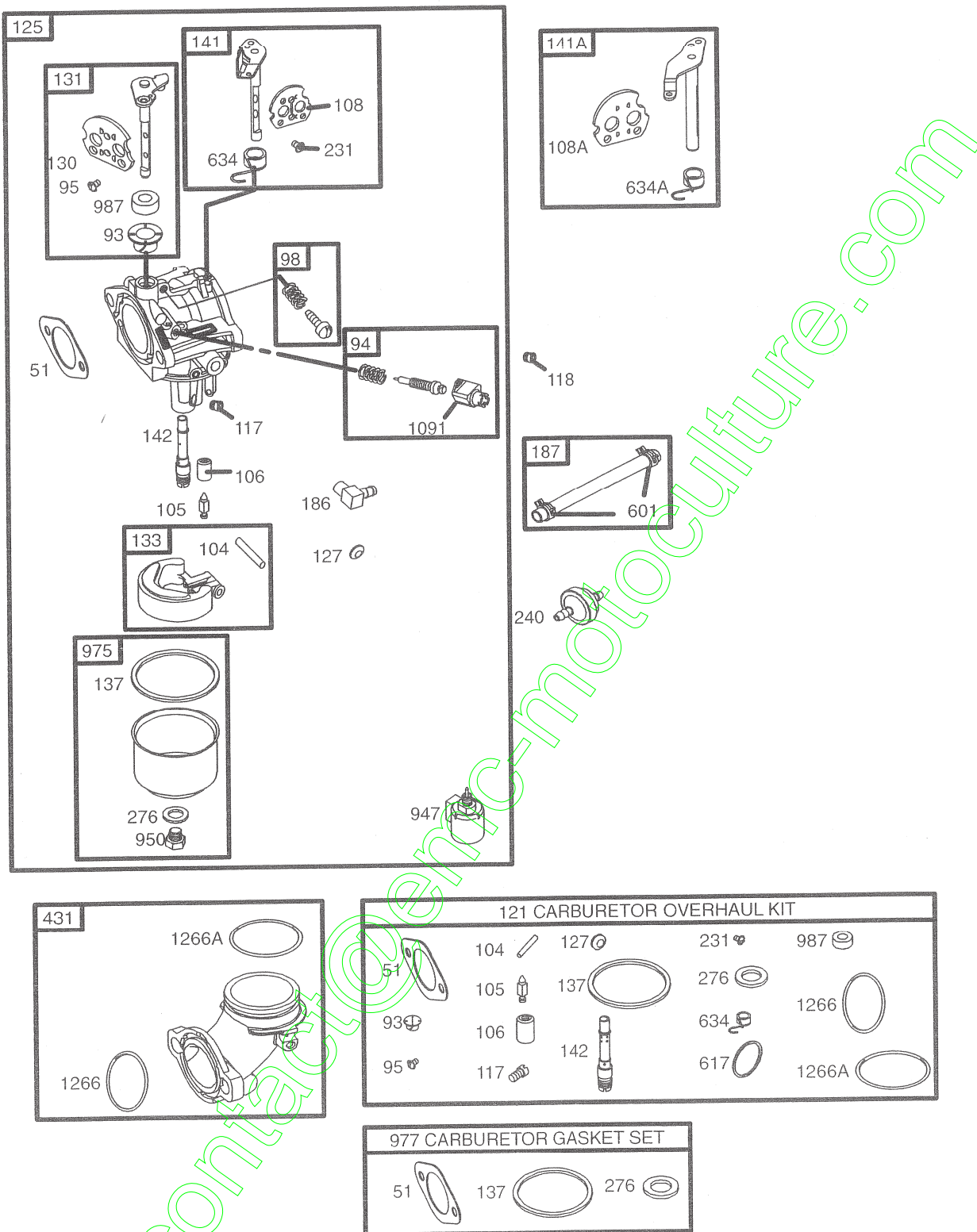

REPAIR PARTS

TRACTOR- -MODEL NO. 917. 277200
BRIGGS & STRATTON ENGINE-MODEL NUMBER 31C707, TYPE NUMBER 0240-E1

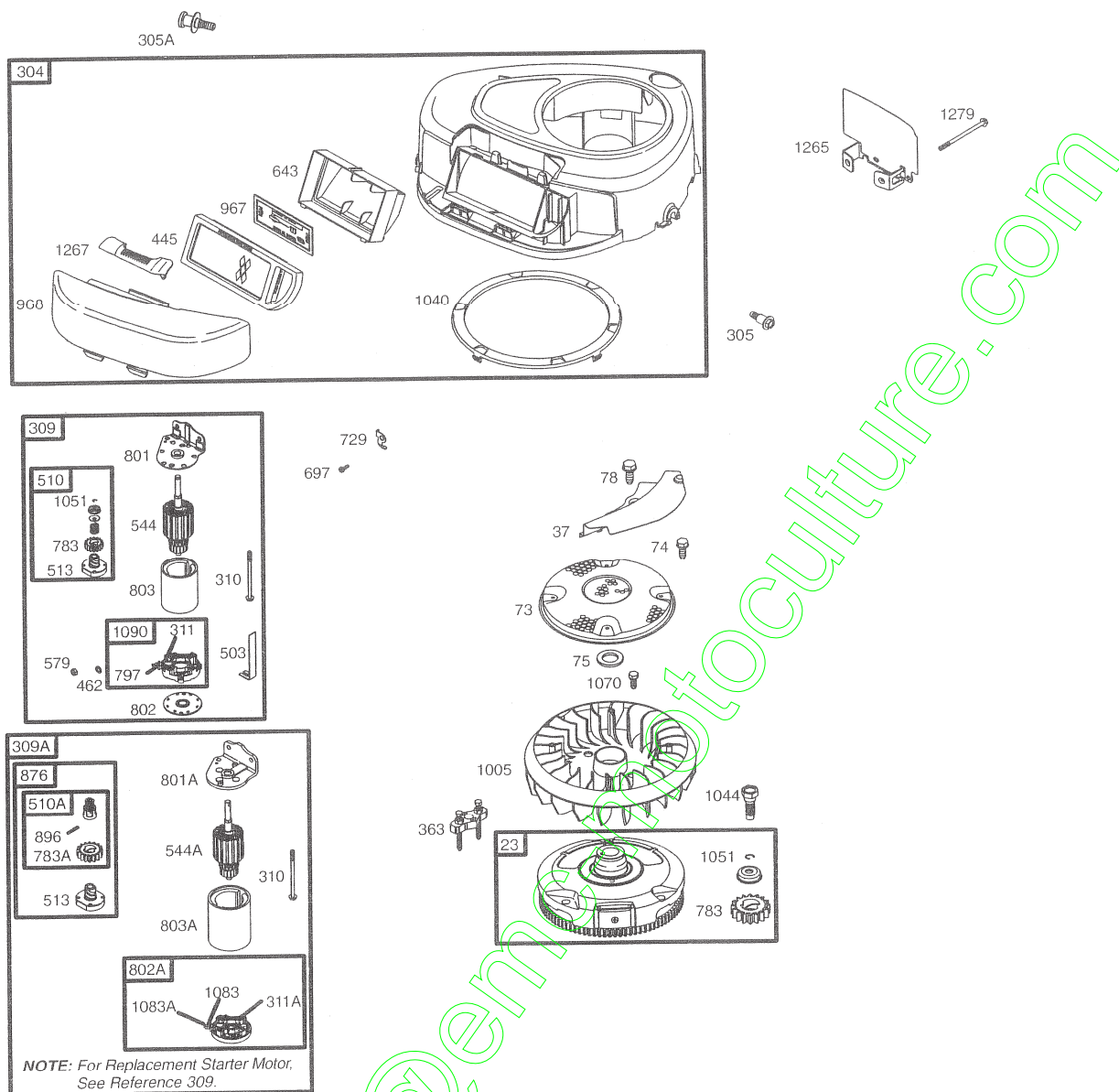

REPAIR PARTS

TRACTOR- -MODEL NO. 917. 277200

BRIGGS & STRATTON ENGINE-MODEL NUMBER 31C707, TYPE NUMBER 0240-E1

KEY PART NO.	NO.	DESCRIPTION	KEY PART NO.	NO.	DESCRIPTION
1	697174	Cylinder Assembly	118	697492	Jet-Main (High Altitude)
2	399265	Kit-Bushing/Seal (Magneto Side)	121	697241	Kit-Carburetor Overhaul
3	391086	• Seal-Oil (Magneto Side)	125	697190	Carburetor
4	697106	Sump-Engine	127	695005	Plug-Welch
5	698147	Head-Cylinder	130	691750	Valve-Throttle
7	692410	•+ Gasket-Cylinder Head	131	494379	Kit-Throttle Shaft
9	697109	• Gasket-Breather	133	494381	Float-Carburetor
10	697157	Screw (Breather Assembly)	137	281165	Ø‡Gasket-Float Bowl
11	697113	Tube-Breather	141	495097	Kit-Choke Shaft (Manual Choke)
12	697110	• Gasket-Crankcase	141A	495931	Kit-Choke Shaft (Choke A Matic)
13	690360	Screw (Cylinder Head)	142	697140	Ø Nozzle-Carburetor
15	690946	Plug-Oil Drain	146	691639	Key-Timing
16	697127	Crankshaft	186	692317	Connector-Hose
20	690947	• Seal-Oil (PTO Side)	187	691050	Line-Fuel (Cut to Required Length)
22	692125	Screw (Crankcase Cover/Sump)	188	691693	Screw (Control Bracket)
23	693557	Flywheel	192	691986	Adjuster-Rocker Arm
24	222698	Key-Flywheel	202	691841	Link-Mechanical Governor
25	697159	Piston Assembly (Standard)	209	692208	Spring-Governor
	697160	Piston Assembly (.010" Oversize)	222	694042	Bracket-Control
	697162	Piston Assembly (.020" Oversize)	227	691374	Lever-Governor Control
	697163	Piston Assembly (.030" Oversize)	231	691636	Screw (Choke Valve)
26	697164	Ring Set (Standard)	232	691842	Spring-Governor
	697165	Ring Set (.010" Oversize)	238	691843	Cap-Valve
	697171	Ring Set (.020" Oversize)	240	394358	Filter-Fuel
	697172	Ring Set (.030" Oversize)	265	691024	Clamp-Casing
27	697100	Lock-Piston Pin	267	695134	Screw (Casing Clamp)
28	697099	Pin-Piston	276	692255	Ø‡Washer-Sealing
29	697126	Rod-Connecting (Standard)	304	698402	Housing-Blower
32	692852	Screw (Connecting Rod)	305	697102	Screw (Blower Housing)
33	495856	Valve-Exhaust	305A	697103	Screw (Blower Housing)
34	495857	Valve-Intake	306	697107	Shield-Cylinder
35	691279	Spring-Valve (Intake)	307	691003	Screw (Cylinder Shield)
36	691279	Spring-Valve (Exhaust)	309	693551	Motor-Starter
37	697352	Guard-Flywheel	309A	-----	Motor-Starter (For Replacement Starter Motor, See Reference 309)
40	691752	Retainer-Valve	310	690323	Bolt (Starter Motor)
43	691968	Slinger-Governor/Oil	311	497608	Brush Set
45	690564	Tappet-Valve	311A	395538	Brush Set
46	697687	Camshaft	333	492341	Armature-Magneto
48	697761	Short Block (31C707-0240-E2 Replacement Engine-art not available)	334	691061	Screw (Magneto Armature)
50	690193	Manifold-Intake	337	691043	Plug-Spark
51	692137	•Ø‡+ Gasket-Intake	358	697191	Gasket Set-Engine
53	690227	Stud (Carburetor)	363	19203	Flywheel Puller
54	691148	Screw (Intake Manifold)	383	89838	Wrench-Spark Plug
73	697384	Screen-Rotating	404	691691	Washer (Governor Crank)
74	697987	Screw (Rotating Screen)	431	697122	Elbow-Intake
75	690582	Washer (Flywheel)	RPM Settings:		Low Speed: 1900-2100
78	691003	Screw (Flywheel Guard)			High Speed: 3000-3200
93	690602	Ø Bushing-Throttle Shaft			
94	498030	Kit-Idle Mixture			
95	691636	Screw (Throttle Valve)			
98	495800	Kit-Idle Speed			
104	690525	Ø Pin-Float Hinge			
105	231855	Ø Valve-Float Needle			
106	690577	Ø Seat-Inlet			
108	690464	Valve-Choke (Manual Choke)			
108A	692344	Valve-Choke (Choke A Matic)			
117	694352	Ø Jet-Main (Standard)			

- Included in Engine Gasket Set, Key. No. 358
- Ø Included in Carburetor Overhaul Kit, Key. No. 121
- ‡ Included in Carburetor Gasket Set, Key. No. 977
- + Included in Valve Gasket Set, Key. No. 1095

NOTE: All component dimensions given in U.S. inches 1 inch = 25.4 mm

REPAIR PARTS

TRACTOR- -MODEL NO. 917. 277200

BRIGGS & STRATTON ENGINE-MODEL NUMBER 31C707, TYPE NUMBER 0240-E1

KEY PART NO.	PART NO.	DESCRIPTION	KEY PART NO.	PART NO.	DESCRIPTION
445	698083	Filter-Air Cleaner Cartridge	876	495877	Kit-Pinion Spring
462	691261	Washer (Starter Cable)	877	393456	Wire-Connector/Alternator
474	696459	Alternator	896	691641	Pin-Drive Retainer
503	691532	Strap-Starter	914	690960	Screw (Rocker Cover)
505	691251	Nut (Governor Control Lever)	947	694393	Solenoid-Fuel
510	693699	Drive-Starter	950	691657	Screw (Float Bowl)
510A	497606	Drive-Starter	967	697015	Filter-Pre Cleaner
513	692024	Clutch-Drive	968	698403	Cover-Air Cleaner
523	697086	Dipstick	975	495933	Bowl-Float
524	691032	• Seal-Dipstick Tube	977	690192	Gasket Set-Carburetor
525	697184	Tube-Dipstick	987	691326	∅ Seal-Throttle Shaft
544	692034	Starter-Armature	100b	697853	Fan-Flywheel
544A	390837	Starter-Armature	1019	697143	Kit-Label
552	697144	Bushing-Governor Crank	1022	272475	•+ Gasket-Rocker Cover
559	697561	Screw (Remote Choke Stop)	1023	692492	Cover-Rocker Arm
559A	693675	Screw (Remote Choke Stop)	1026	692003	Rod-Push (Intake)
562	691119	Bolt (Governor Control Lever)		692011	Rod-Push (Exhaust)
579	691029	Nut (Starter Cable)	1029	691751	Arm-Rocker
584	697112	Cover-Breather Passage	1034	690822	Guide-Push Rod
601	95162	Clamp-Hose	1036	695700	Label-Emission
614	691620	Pin-Cotter	1040	698368	Plate-Trim
616	692012	Crank-Governor	1044	691658	Screw (Flywheel)
617	692138	∅ •Seal-O Ring (Intake Manifold)	1051	691265	Ring-Retaining
634	690801	∅ Spring/Seal Assembly (Manual Choke)	1058	275038	Owner's Manual
634A	690802	∅ Spring/Seal Assembly (Choke A Matic)	1059	698516	Kit-Screw/Washer
635	691909	Boot-Spark Plug	1070	690372	Screw (Flywheel Fan)
643	698401	Retainer-Air Filter	1083	691626	Nut (Starter Terminal)
654	690958	Nut (Carburetor)	1083A	690958	Nut (Starter Terminal)
691	692407	• Seal-Governor Shaft	1090	691293	Retainer-Brush
697	690372	Screw (Drive Cap)	1091	691333	Cap-Limiter
718	690959	Pin-Locating	1095	690190	Gasket Set-Valve
729	691224	Clip-Wire	1119	691183	Screw (Alternator)
741	697128	Gear-Timing	1263	697124	Reed-Breather
757	697607	Link-Counterweight	1264	697104	Screw (Breather Reed)
758	697134	Counterweight	1265	697125	Support-Blower Housing
759	697392	Pin-Counterweight	1266	691917	•∅ Seal-O Ring (Intake Elbow)
783	693713	Gear-Pinion	1266A	697123	∅ Seal-O Ring (Intake Elbow)
783A	693059	Gear-Pinion	1267	697575	Latch-Blower Housing
789	698329	Harness-Wiring	1270	697156	Plug-AVS Counterweight
797	693167	Nut (Brush Retainer)	1279	690960	Screw (Blower Housing Support)
801	691283	Cap-Drive			RPM Settings:
801A	394856	Cap-Drive			Low Speed: 1900-2100
802	691286	Cap-End			High Speed: 3000-3200
802A	395537	Cap-End			
803	693757	Housing-Starter			• Included in Engine Gasket Set, Key. No. 358
803A	398159	Housing-Starter			∅ Included in Carburetor Overhaul Kit, Key. No. 121
830	691095	Stud (Rocker Arm)			‡ Included in Carburetor Gasket Set, Key. No. 977
842	691031	• Seal-O Ring (Dipstick Tube)			+ Included in Valve Gasket Set, Key. No. 1095
847	697611	Dipstick/Tube Assembly			
851	692424	Terminal-Spark Plug			NOTE: All component dimensions given in U.S. inches 1 inch =
868	690968	•+ Seal-Valve			25.4 mm

LIMITED WARRANTY ON CRAFTSMAN RIDING EQUIPMENT

For two (2) years from the date of purchase, if this Craftsman Riding Equipment is maintained, lubricated and tuned up according to the instructions in the owner's manual, Sears will repair or replace free of charge any parts that are found to be defective in material or workmanship according to the guidelines of coverage listed below. Sears will also provide free labor for these applicable warranted parts for the two full years. During the first 30 days of purchase, there will be no charges to service the product at your home for issues covered by this warranty. (See exclusions below). For your convenience, IN HOME warranty service will still be available after the first 30 days of purchase, but a trip charge will apply. This charge will be waived if the Craftsman product is dropped off at an authorized Sears location. For the nearest authorized Sears location, please call 1-800-4-MY-HOME®. This warranty applies only while this product is within the United States.

THIS WARRANTY DOES NOT COVER:

Expendable items which become worn during normal use, including but not limited to blades, spark plugs, air cleaners, belts, and oil filters.

Standard Maintenance Servicing, oil changes, or tune-ups

Tire replacement or repair caused by punctures from outside objects, such as nails, thorns, stumps, or glass.

Repairs necessary because of operator abuse, including but not limited to, damage caused by towing objects beyond the capability of the riding equipment, impacting objects that bend the frame or crankshaft, or over-speeding the engine.

Repairs necessary because of operator negligence, including but not limited to, electrical and mechanical damage caused by improper storage, failure to use the proper grade and amount of engine oil, failure to keep the deck clear of flammable debris, or failure to maintain the equipment according to the instructions contained in the owner's manual.

Engine (fuel system) cleaning or repairs caused by fuel determined to be contaminated or oxidized (stale). In general, fuel should be used within 30 days of its purchase date.

Normal deterioration and wear of the exterior finishes, or product label replacement.

Riding equipment used for commercial or rental purposes.

LIMITED WARRANTY ON BATTERY

For ninety (90) days from date of purchase, if any battery included with this riding equipment proves defective in material or workmanship and our testing determines the battery will not hold a charge, Sears will replace the battery at no charge. During the first 30 days of purchase, there will be no charges to replace the battery at your HOME. After the first 30 days, for your convenience, IN-HOME warranty service will still be available but a trip charge will apply. This charge will be waived if the Craftsman product is dropped off at an authorized Sears location. For the nearest authorized Sears location, please call 1-800-4-MY-HOME®.

This battery warranty applies only while this product is within the United States.

This warranty gives you specific legal rights, and you may also have other rights, which vary, from state to state.

Sears, Roebuck and Co., Dept. 817WA, Hoffman Estates, IL 60179

