

87C 145F 145/96 8722A.

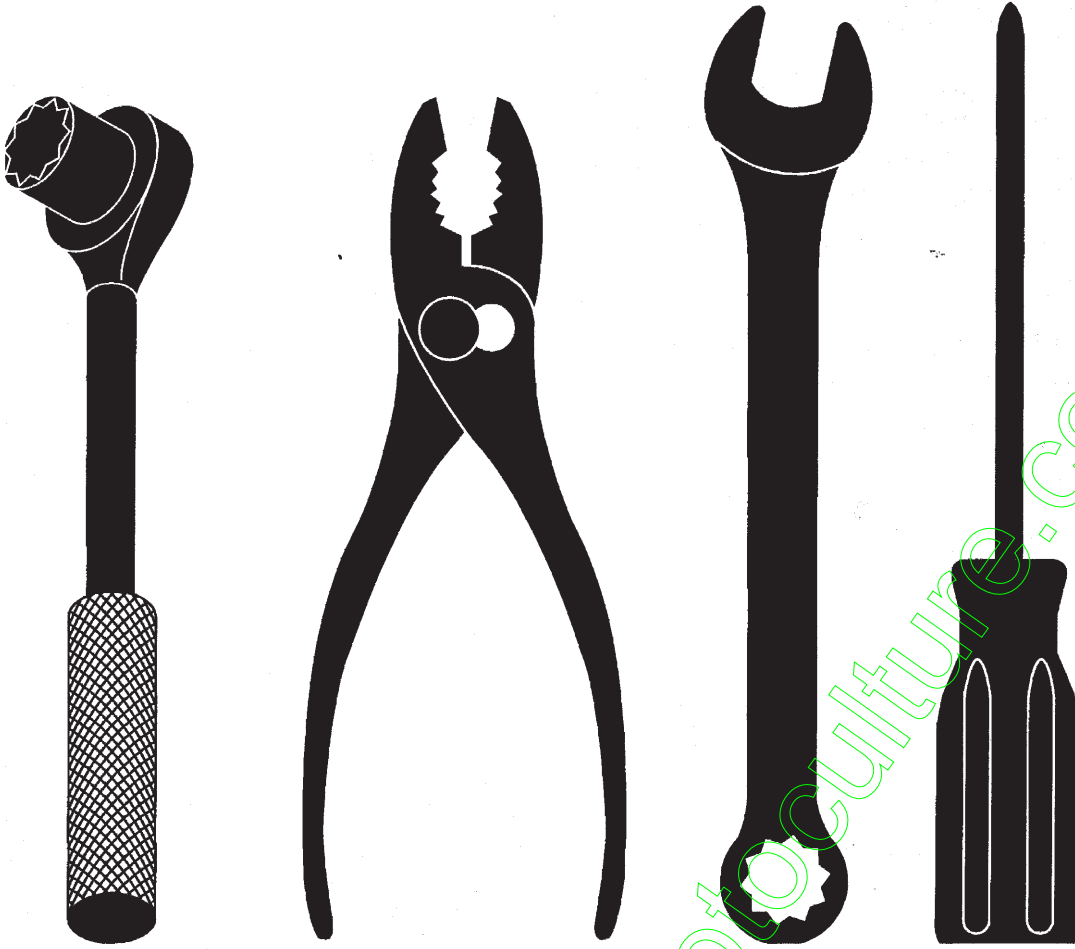

REPAIR PARTS MANUAL
MODEL NO. 277331
Lawn Tractor

CRAFTSMAN®

HOW TO USE THIS MANUAL

This manual is designed to provide the customer with a means to identify the parts on his/her tractor when ordering repair parts. The illustrations may or may not represent the actual assemblies; therefore, it is not recommended to use this manual as a guide to assemble or disassemble the tractor. Some hardware and parts are drawn larger in order to more readily identify them.

Each tractor has its own model number.

The model number for your tractor can be found on the fender under the seat.

When ordering parts, always give the following information:

- Product - "Tractor"
- Model Number - "277331"
- Part Number
- Part Description

TABLE OF CONTENTS

SCHEMATIC	3
ELECTRICAL.....	4-5
CHASSIS.....	6-7
DRIVE.....	8-9
STEERING.....	10-11
SEAT	12
DECALS.....	13
ENGINE.....	14-15
MOWER LIFT	16-17
MOWER DECK	18-19
TRANSAXLE.....	20-21
ENGINE BREAKDOWN.....	22-27
WARRANTY.....	28

TRACTOR--MODEL NO. 917. 277331

SCHEMATIC

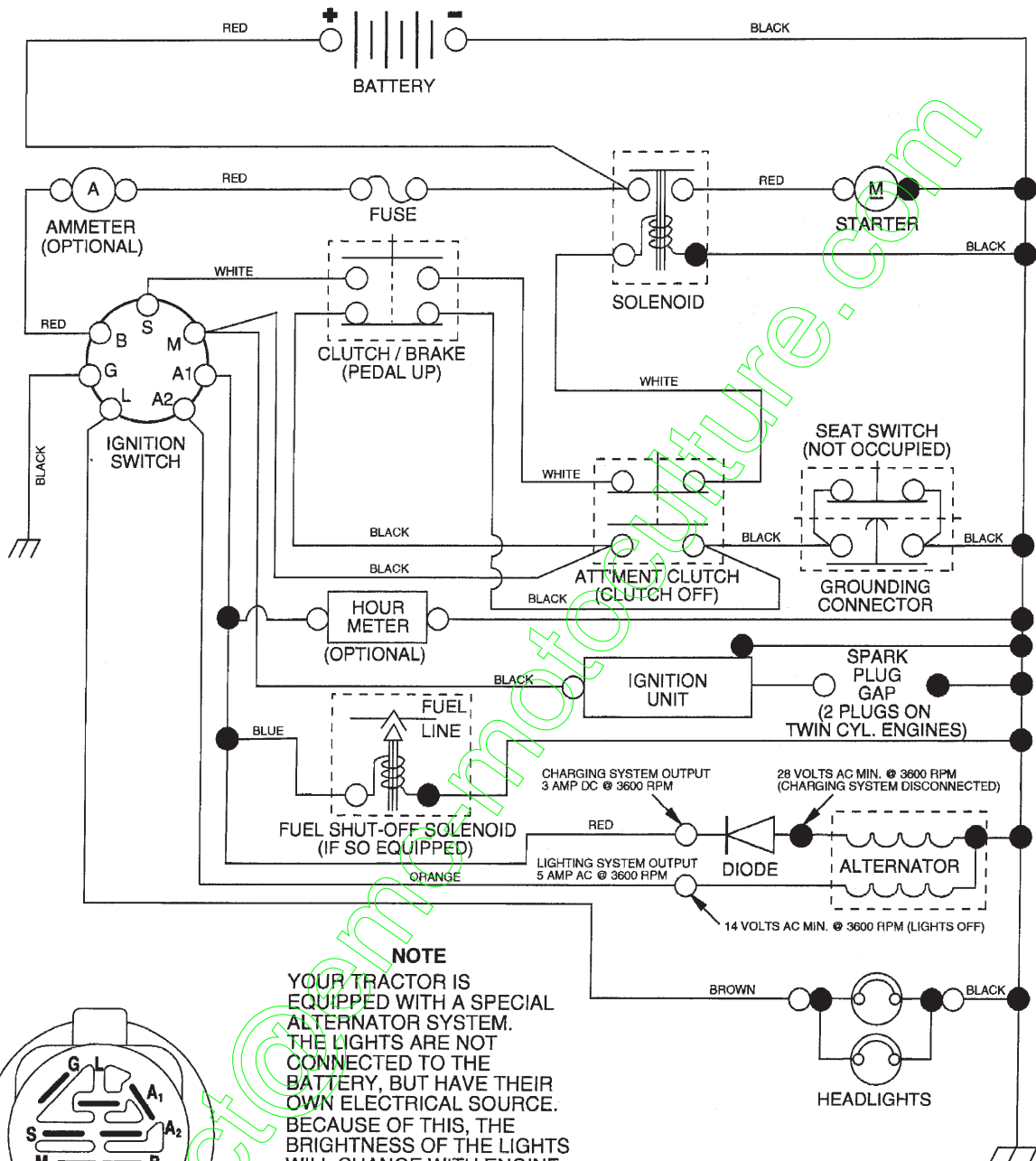

NOTE

YOUR TRACTOR IS EQUIPPED WITH A SPECIAL ALTERNATOR SYSTEM. THE LIGHTS ARE NOT CONNECTED TO THE BATTERY, BUT HAVE THEIR OWN ELECTRICAL SOURCE. BECAUSE OF THIS, THE BRIGHTNESS OF THE LIGHTS WILL CHANGE WITH ENGINE SPEED. AT IDLE THE LIGHTS WILL DIM. AS THE ENGINE IS SPEEDED UP, THE LIGHTS WILL BECOME THEIR BRIGHTEST.

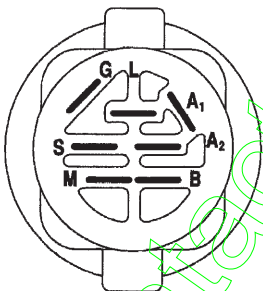

IGNITION SWITCH

POSITION	CIRCUIT	"MAKE"
OFF	M+G+A1	NONE
RUN/LIGHT	B+A1	A2+L
RUN	B+A1	NONE
START	B+S+A1	NONE

WIRING INSULATED CLIPS

NOTE: IF WIRING INSULATED CLIPS WERE REMOVED FOR SERVICING OF UNIT, THEY SHOULD BE REPLACED TO PROPERLY SECURE YOUR WIRING.

02363

NON-REMOVABLE CONNECTIONS

REMOVABLE CONNECTIONS

REPAIR PARTS

TRACTOR- -MODEL NO. 917. 277331

ELECTRICAL

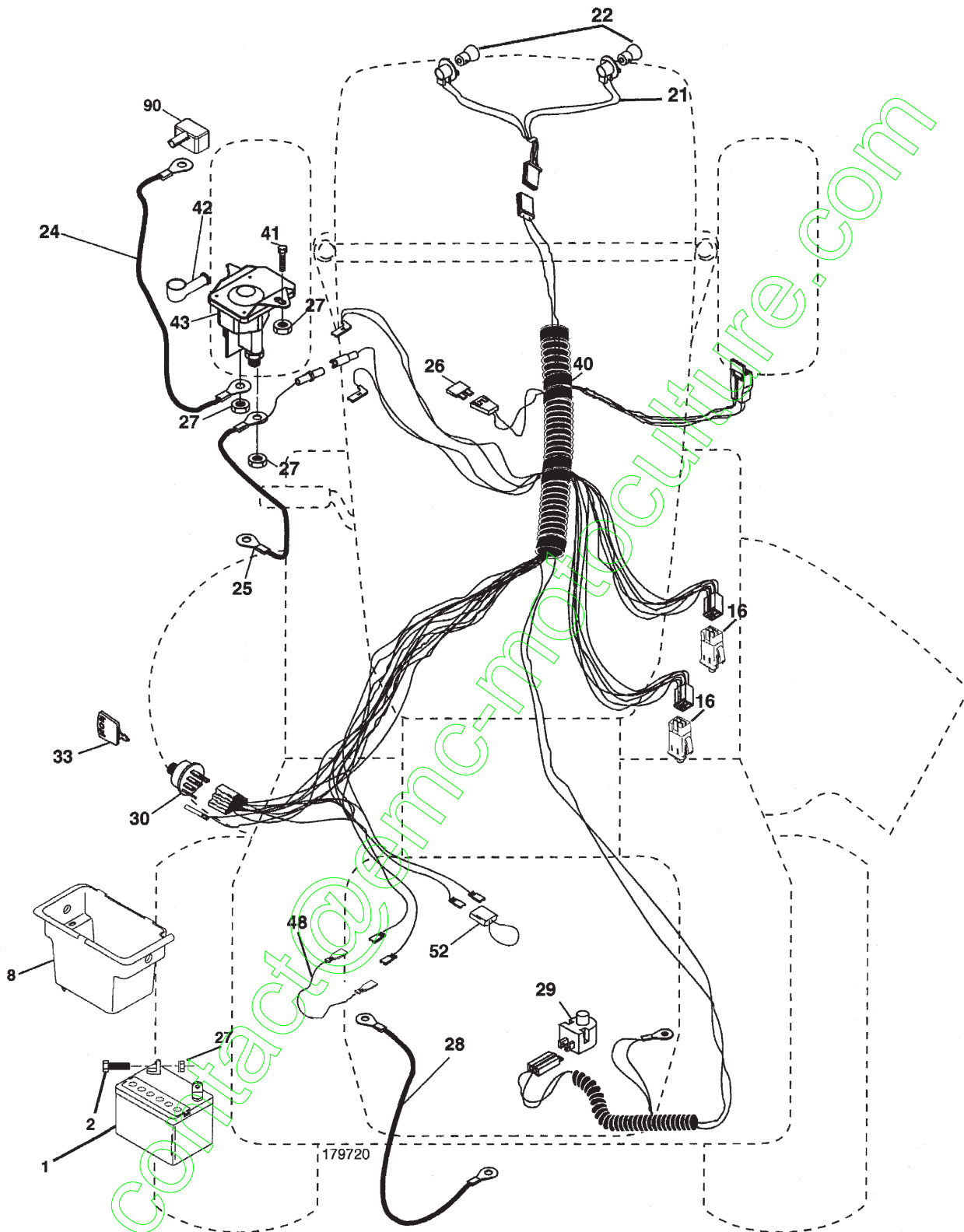

REPAIR PARTS

TRACTOR- -MODEL NO. 917. 277331

ELECTRICAL

KEY NO.	PART NO.	DESCRIPTION
1	163465	Battery
2	74760412	Bolt Hex Hd 1/4-20 unc x 3/4
8	176689	Box Battery Fender
16	176138	Switch, Interlock
21	183759	Harness Asm Light W/4152j
22	4152J	Bulb Light #1156
24	4799J	Cable Battery 6 Ga. 11" red
25	146147	Cable Battery 6 Ga. w/16 wire red
26	175158	Fuse 20 AMP
27	73510400	Nut, Keps Hex 1/4-20 unc
28	4207J	Cable Ground 6 Ga. 12" black
29	121305X	Switch Plunger Nc Gray
30	175566	Switch Ign
33	140403	Key Ign Molded Craftsman
40	179720	Harness Ign
41	71110408	Bolt Blk. Fin Hex 1/4-20 Unc x 1/2
42	131563	Cover Terminal Red
43	192507	Solenoid
48	140844	Ammeter Adapter
52	141940	Protection Wire Loop
90	180449	Cover Battery Terminal

NOTE: All component dimensions give in U.S. inches
1 inch = 25.4 mm

REPAIR PARTS

TRACTOR- -MODEL NO. 917. 277331

CHASSIS AND ENCLOSURES

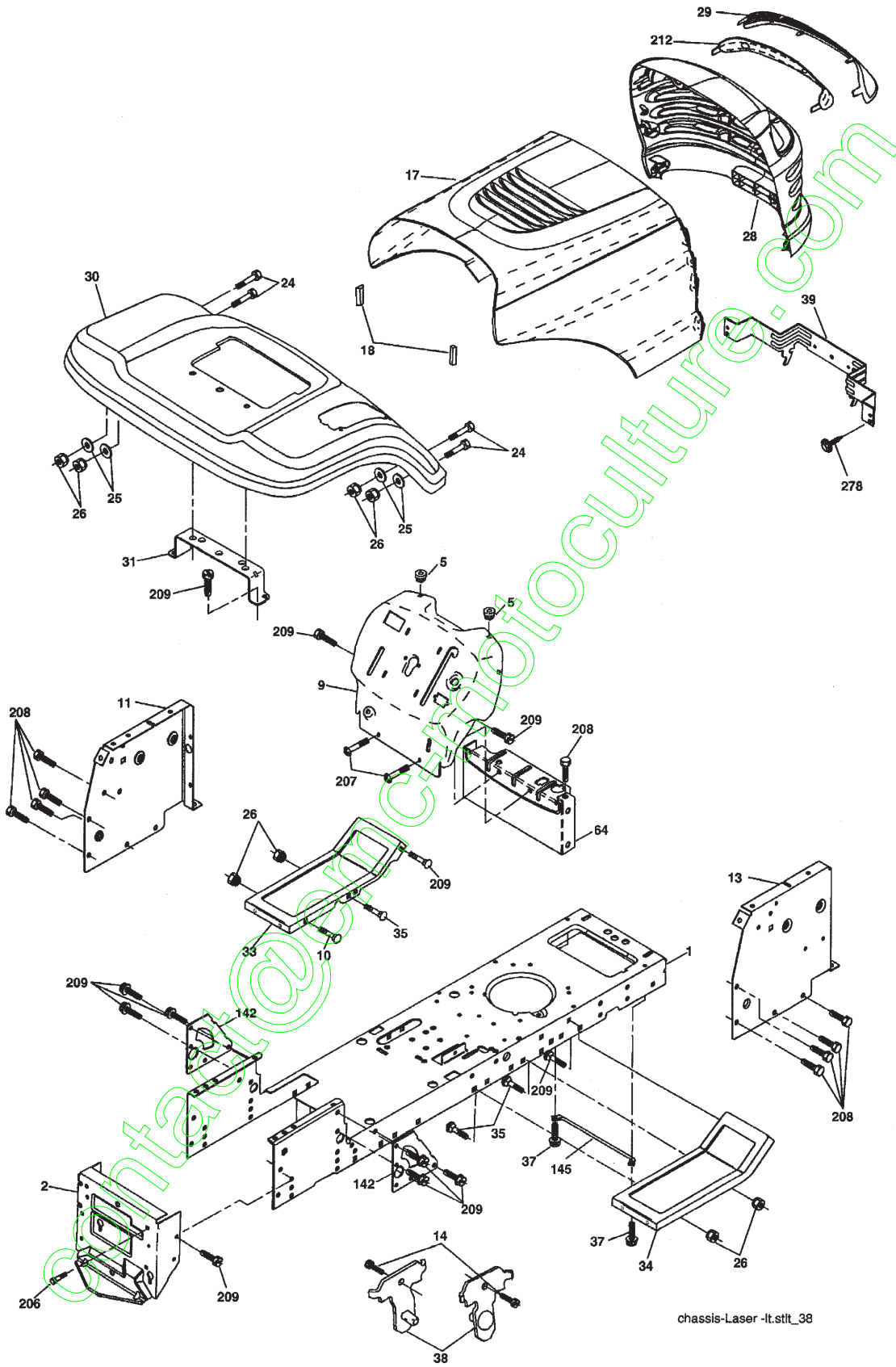

chassis-Laser -lt.stlt_38

REPAIR PARTS

TRACTOR- -MODEL NO. 917. 277331

CHASSIS AND ENCLOSURES

KEY NO.	PART NO.	DESCRIPTION
1	174619	Chassis Stamping
2	176554	Drawbar
5	155272	Bumper Hood/Dash
9	193510X013	Dash
10	STD533710	Bolt, Rdhd Sqnk 3/8-16 x 1
11	174996	Panel, Dash, L.H.
13	172105X010	Panel, Dash, R.H.
14	17490608	Screw Thdrol 3/8-16 x 1/2
17	185682X613	Hood Assembly Laser
18	184921	Bumper Extrusion
24	74780616	Bolt Fin Hex 3/8-16 unc x 1 Gr. 5
25	19131312	Washer 13/32 x 13/16 x 12 Ga.
26	STD541437	Nut
28	193258	Grille Lens Asm (Include Key #'s 29 and 212)
29	174332X599	Lens, Laser
30	192526X613	Fend/Ftrest Pnt STLT
31	136619	Bracket, Fender Support
33	179716X613	Footrest LH
34	179717X613	Footrest RH
35	72110606	Bolt Rdhd Sht Sqnk 3/8-16 x 3/4
37	17490508	Screw Thdrol 5/16-18 x 1/2 Tyt
38	175710	Bracket Asm. Pivot Mower Rear
39	174714	Bracket Pivot
64	154798	Dash Lower STLT
142	175702	Plate Reinforcement STLT
145	156524	Jod Pivot Chassis/Hood
206	170165	Bolt Shoulder 5/16 -18 TT
207	17670508	Screw Thdrol 5/16-18 x 1/2 TYTT
208	17670608	Screw Thdrol 3/8-16 x 1/2
209	17000612	Screw Thdrol 3/8-16 x 3/4
212	175143	Insert Lens Reflective
278	191611	Screw 10 x 3/4 Single Lead-Hex
--	193640X428	Plug Switch Light
--	5479J	Plug, Button

NOTE: All component dimensions given in U.S. inches
1 inch = 25.4 mm

REPAIR PARTS

TRACTOR- -MODEL NO. 917. 277331

DRIVE

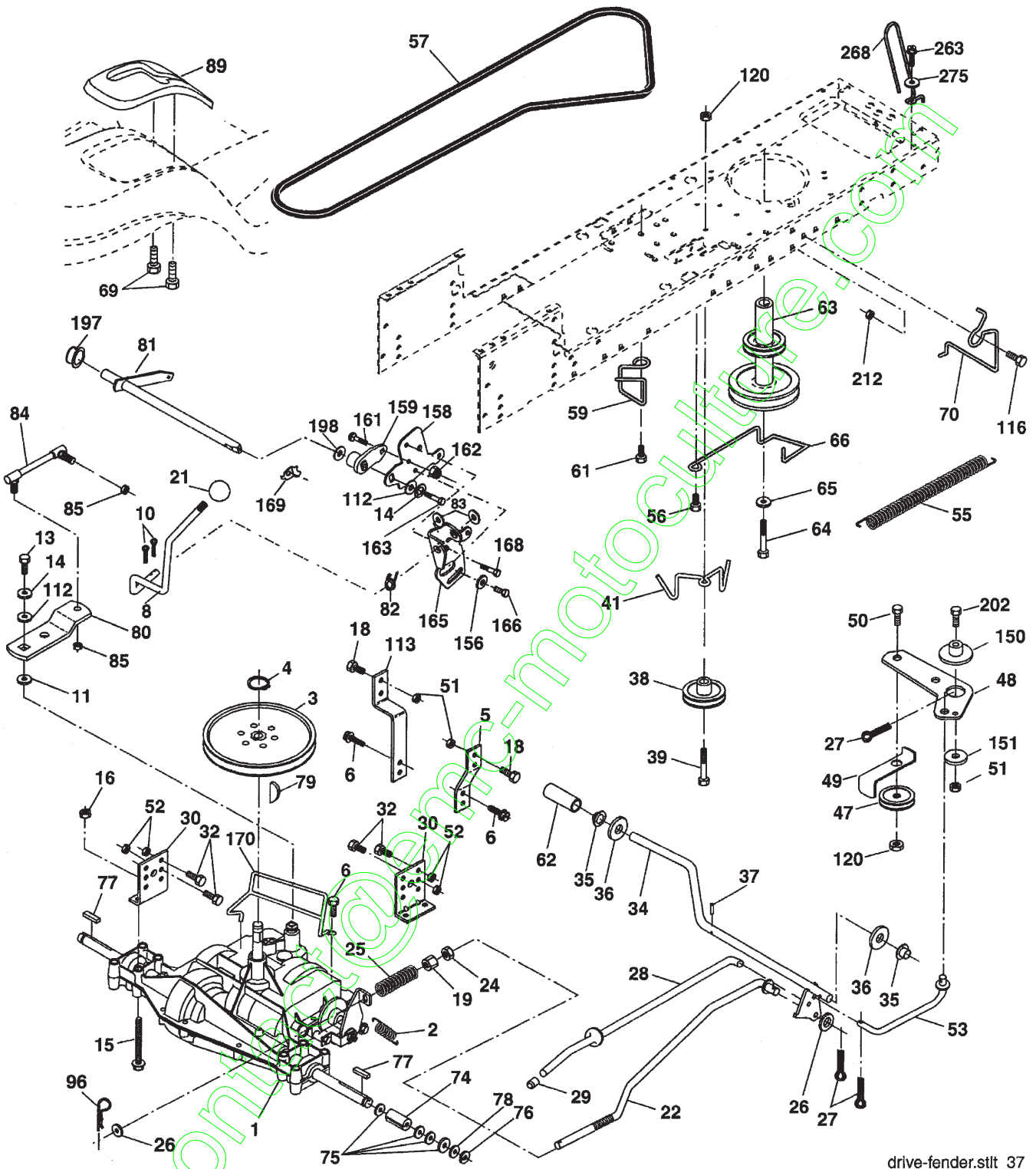

drive-fender.stlt_37

REPAIR PARTS

TRACTOR- -MODEL NO. 917. 277331

DRIVE

KEY NO.	PART NO.	DESCRIPTION	KEY NO.	PART NO.	DESCRIPTION
1	-----	Transaxle (See Breakdown) Dana D4360-140	64	173937	Bolt Hex 7/16-20 x 4 x Gr. 5
2	146682	Spring Brake Return	65	STD551143	Washer
3	123666X	Pulley Transaxle	66	154778	Keeper Belt Engine Hydro
4	12000028	Ring Retainer	69	142432	Screw Hex Wsh Hi-Lo 1/4-1/2 unc
5	121520X	Strap Torque 30 Degrees	70	180218	Keeper Belt Engine
6	17000512	Screw 5/16-18 x 3/4	74	109502X	Spacer
8	192706	Rod Shift Fender Adjust	75	121749X	Washer 25/32 x 1-1/4 x 16 Ga.
10	STD561210	Pin Cotter 1/8 x 1 CAD	76	STD581075	E-Ring
11	105701X	Washer Plate Shift	77	123583X	Key, Square
13	74550412	Bolt 1/4-28unf Gr. 8 W/Patch	78	121748X	Washer 25/32 x 1-5/8 x 16 Ga.
14	10040400	Washer Lock Hvy Helical	79	2228M	Key Woodruff
15	74490544	Bolt Hex FLGHD 5/16-18 x Gr. 5	80	131488	Arm Shift
16	STD541431	Nut Lock Hex W/Ins. 5/16-18 unc	81	165594	Shaft Asm Cross Tapered
18	74780616	Bolt Fin Hex 3/8-16 x 1 Gr. 5	82	165711	Spring Torsion
19	STD541437	Nut Lock Hex W/Wsh 3/8-16 unc	83	19171216	Washer 17/32 x 3/4 x 16 Ga.
21	106933X	Knob	84	166229	Link Transaxle
22	130804	Rod, Brake	85	150360	Nut Lock Center 1/4-20
24	73350600	Nut, Hex Jam 3/8-16 unc	89	192053X428	Console, Shift
25	106888X	Spring, Brake Rod	96	4497H	Retainer Spring 1" Zinc/Cad
26	STD551037	Washer 13/32 x 13/16 Ga.	112	19091210	Washer 9/32 x 3/4 x 10 Ga.
27	STD561210	Pin Cotter 1/8 x 3/4 CAD.	113	127285X	Strap Torque 90 Degrees
28	175765	Rod, Parking Brake	116	72140608	Bolt Rdhd Sqneck 3/8-16 x 1.25
29	71673	Cap, Parking Brake	120	73900600	Nut Lock Flg 3/8-16
30	174973	Bracket, Transaxle	150	175456	Spacer Retainer
32	74760512	Bolt Hex Hd 5/16-18 unc x 3/4	151	19133210	Washer 13/32 x 2 x 10 Ga.
34	175578	Shaft, Foot Pedal	156	166002	Washer Srrted 5/16 ID x 1.125
35	120183X	Bearing, Nylon	158	165589	Bracket Shift Mount
36	19211616	Washer	159	183900	Hub Shift
37	1572H	Pin, Roll	161	72140406	Bolt Rdhd Sqnk 1/4-20 x 3/4 Gr 5
38	179114	Pulley, Composite, Flat	162	73680400	Nut Crownlock 1/4-20 unc
39	72110622	Bolt Rdhd 3/8-16 unc x 2-3/4 Gr. 5	163	74780416	Bolt Hex Fin 1/4-20 unc x 1 Gr 5
41	175556	Keeper, Belt Idler	165	165623	Bracket Pivot Lever
47	127783	Pulley, Idler, V-Groove	166	17490510	Screw 5/16-18 x 5/8
48	154407	Bellcrank, Clutch	168	165492	Bolt Shoulder 5/16-18 x .561
49	123205X	Retainer, Belt	169	165580	Plate Fastening
50	72110612	Bolt Carr 3/8-16 x 1-1/2	170	187414	Keeper Belt T/A
51	STD541437	Nut Crownlock 3/8-16 unc	197	169613	Nyliner Snap-In 5/8"ID
52	STD541431	Nut, Crownlock 5/16-18 unc	198	169593	Washer Nyl 7/8 ID x .105" Hyd
53	105710X	Link, Clutch	202	72110614	Bolt Carr Sh 3/8-16 x 1-3/4 Gr. 5
55	105709X	Spring, Return, Clutch	212	145212	Nut Hex Flg. Lock
56	17060620	Screw 3/8-16 x 1-1/4	263	17000612	Screw 3/8-16 x 3/4
57	160855	V-Belt	268	182402	Guard Muffler
59	169691	Keeper, Center Span	275	19131614	Washer 13/32 x 1 x 14 Ga.
61	17120614	Screw 3/8-16 x .875			
62	8883R	Cover, Pedal			
63	180219	Pulley, Engine			

NOTE: All component dimensions given in U.S. inches
1 inch = 25.4 mm

REPAIR PARTS

TRACTOR- -MODEL NO. 917. 277331

STEERING ASSEMBLY

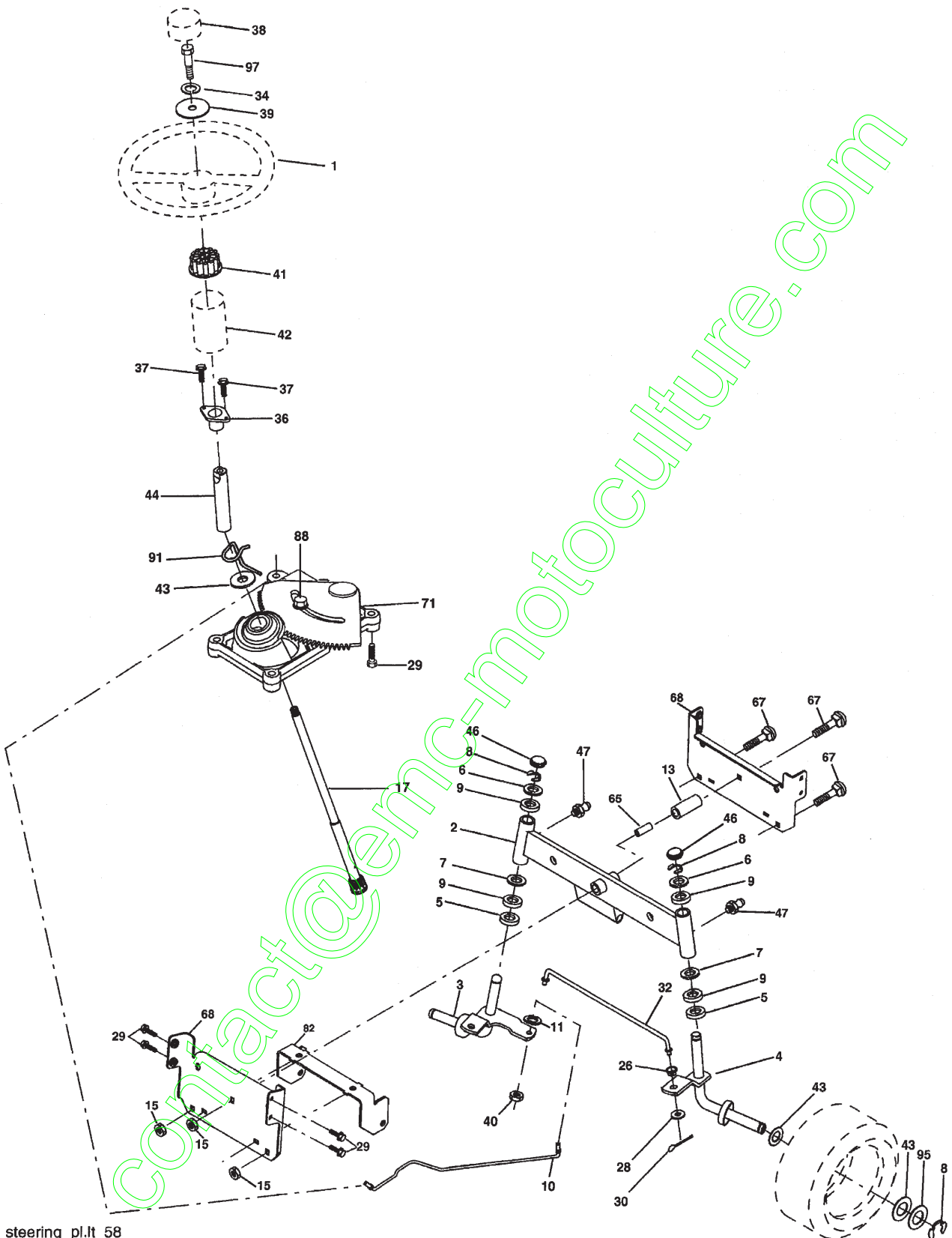

steering_pl.it_58

REPAIR PARTS

TRACTOR- -MODEL NO. 917. 277331

STEERING ASSEMBLY

KEY NO.	PART NO.	DESCRIPTION
1	186780	Steering Wheel
2	175131	Axle Assembly STMP Dropped STL
3	169840	Spindle Assembly, L.H.
4	169839	Spindle Assembly, R.H.
5	6266H	Bearing, Race, Thrust, Hardened
6	121748X	Washer 25/32 x 1-5/8 x 16 Ga.
7	19272016	Washer 27/32 x 1-1/4 x 16 Ga.
8	12000029	Ring, Klip
9	3366R	Bearing, Steering Column
10	175121	Draglink
11	10040600	Washer, Lock
13	136518	Spacer Brg Axle Front
15	145212	Nut, Hexflange Lock
17	190753	Shaft Assembly, Steering
26	126847X	Bushing, Link, Drag
28	19131416	Washer 13/32 x 7/8 x 16 Ga.
29	17000612	Screw 3/8-16 x 3/4
30	STD561210	Pin
32	192757	Rod, Tie
34	10040500	Washer Lock Hvy Hlcl Spr 5/16
36	155099	Bushing, Steering
37	152927	Screw
38	186781	Insert, Steering Wheel
39	19113812	Washer 9/16 x 2-3/8
40	73540600	Nut Crownlock 3/8-24
41	186737	Adaptor, Steering Wheel
42	145054x428	Boot, Steering Shaft
43	121749X	Washer 25/32 x 1-1/4 x 16 Ga.
44	190752	Extension Shaft Steering
46	121232X	Cap, Spindle
47	183226	Fitting, Grease
65	160367	Spacer Brace Axle
67	72110618	Bolt Rdhd Sqnk 3/8-16 x 2-1/4
68	169827	Axle, Brace
71	175146	Steering Asm
82	169835	Bracket Susp Chassis Front
88	175118	Bolt Shoulder 7/16-20
91	175553	Clip Steering
95	188967	Washer Harden .793 x 1.637 x .060
97	74780564	Bolt 5/16-18 unc x 4" L Gr. 5

NOTE: All component dimensions given in U.S. inches
1 inch = 25.4 mm

REPAIR PARTS

TRACTOR- -MODEL NO. 917. 277331

SEAT ASSEMBLY

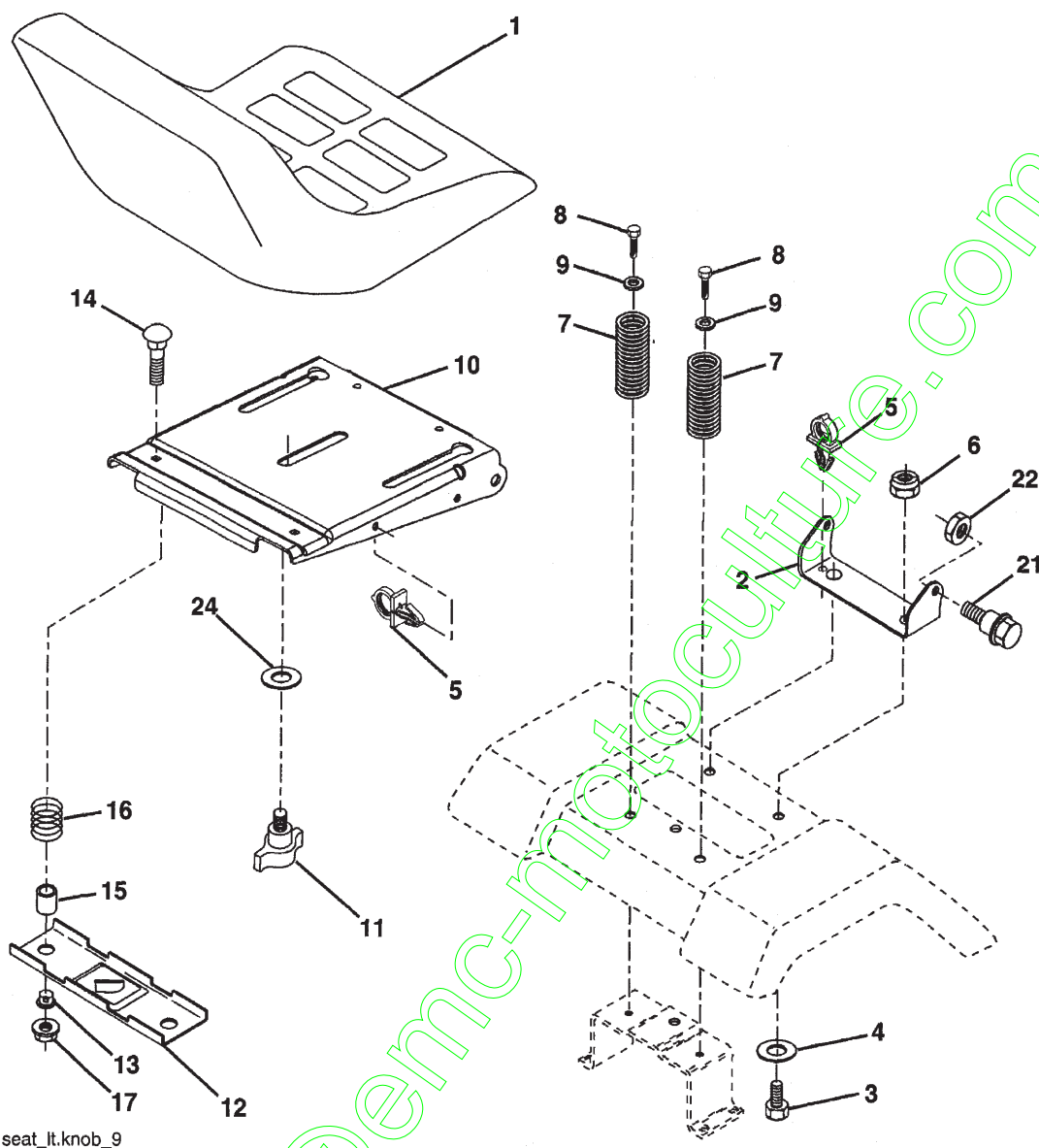

KEY NO.	PART NO.	DESCRIPTION
1	188716	Seat
2	180166	Bracket, Pivot, Seat
3	71110616	Bolt
4	19131610	Washer 13/32 x 1 x 10 Ga.
5	145006	Clip, Push-In Hinged
6	STD541437	Nut
7	124181X	Spring, Seat
8	17000616	Screw 3/8-16 x 1-1/2
9	19131614	Washer 13/32 x 1 x 14 Ga.
10	180186	Pan, Seat
11	166369	Knob Seat
12	121246X	Bracket, Switch Mounting

KEY NO.	PART NO.	DESCRIPTION
13	121248X	Bushing, Snap
14	72050412	Bolt, Carriage 1/4-20 x 1-1/2
15	134300	Spacer, Split .28 x .88
16	121250X	Spring
17	123976X	Locknut, Flange 1/4 Gr. 5
21	171852	Bolt, Shoulder 5/16-18 unc
22	STD541431	Nut
24	19171912	Washer 17/32 x 1-3/16 x 12 Ga.

NOTE: All component dimensions given in U.S. inches
1 inch = 25.4 mm

REPAIR PARTS

TRACTOR- -MODEL NO. 917. 277331

DECALS

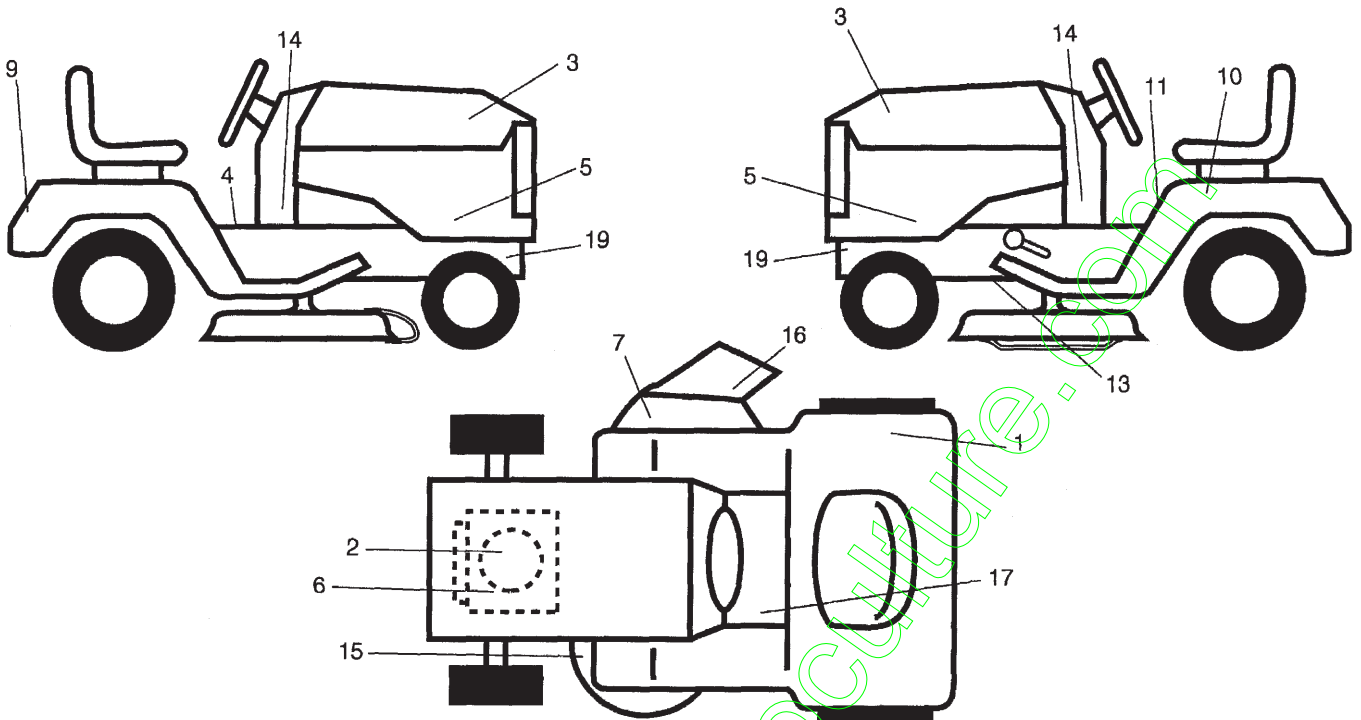

KEY NO.	PART NO.	DESCRIPTION	KEY NO.	PART NO.	DESCRIPTION
1	180432	Decal, Fender DB/CE	14	177097	Decal, Panel Dash
2	198044	Decal, HP Engine	15	136832	Decal, V-Belt Sch
3	196132	Decal, Hood	16	182166	Decal, Cutfinger
4	140837	Decal, Brake Parking	17	159737	Decal, Brake/Clutch Symbol
5	193545	Decal, Sdpnl	19	159736	Decal, Chassis Hot Muffler
6	196841	Decal, Engine Wrng Syms.	--	162598	Decal Drawbar Load Limit
7	196357	Decal, Dflectr Warning Ctfng Sym.	--	138311	Decal, Lift Handle
9	163204	Decal, Fender	--	179768X428	Pad Footrest LH
10	145005	Decal, Battery, Dngr/Psn Eng	--	179769X428	Pad Footrest RH
11	145498	Decal, Read Owner's Manual	--	197340	Operator's Manual, Euro
13	197490	Decal, V-Belt Dr Sch Tractor	--	198098	Manual, Parts

WHEELS & TIRES

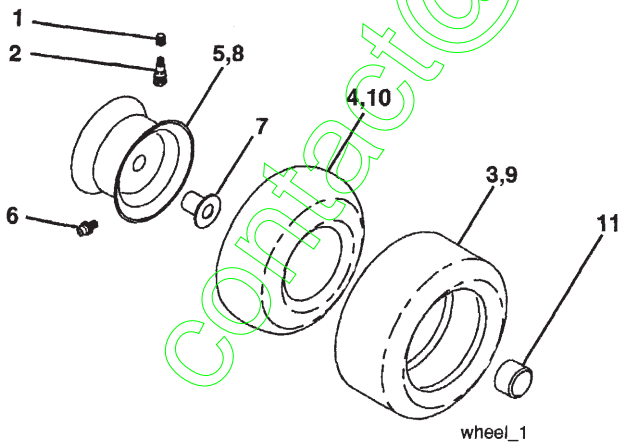

KEY NO.	PART NO.	DESCRIPTION
1	59192	Valve Cap, Tire
2	65139	Stem, Valve
3	106222X	Tire, Front
4	59904	Tube, Front Tire (Not Provided, Service Item Only)
5	106732X624	Rim, Front
6	278H	Fitting, Grease (Front Wheel Only)
7	9040H	Bearing, Flange (Front Wheel Only)
8	106108X624	Rim, Rear
9	124635X	Tire, Rear
10	7152J	Tube, Rear Tire (Not Provided, Service Item Only)
11	104757X428	Cap, Axle
--	144334	Sealant, Tire 10 oz.

NOTE: All component dimensions given in U.S. inches
1 inch = 25.4 mm

REPAIR PARTS

TRACTOR- -MODEL NO. 917. 277331

ENGINE

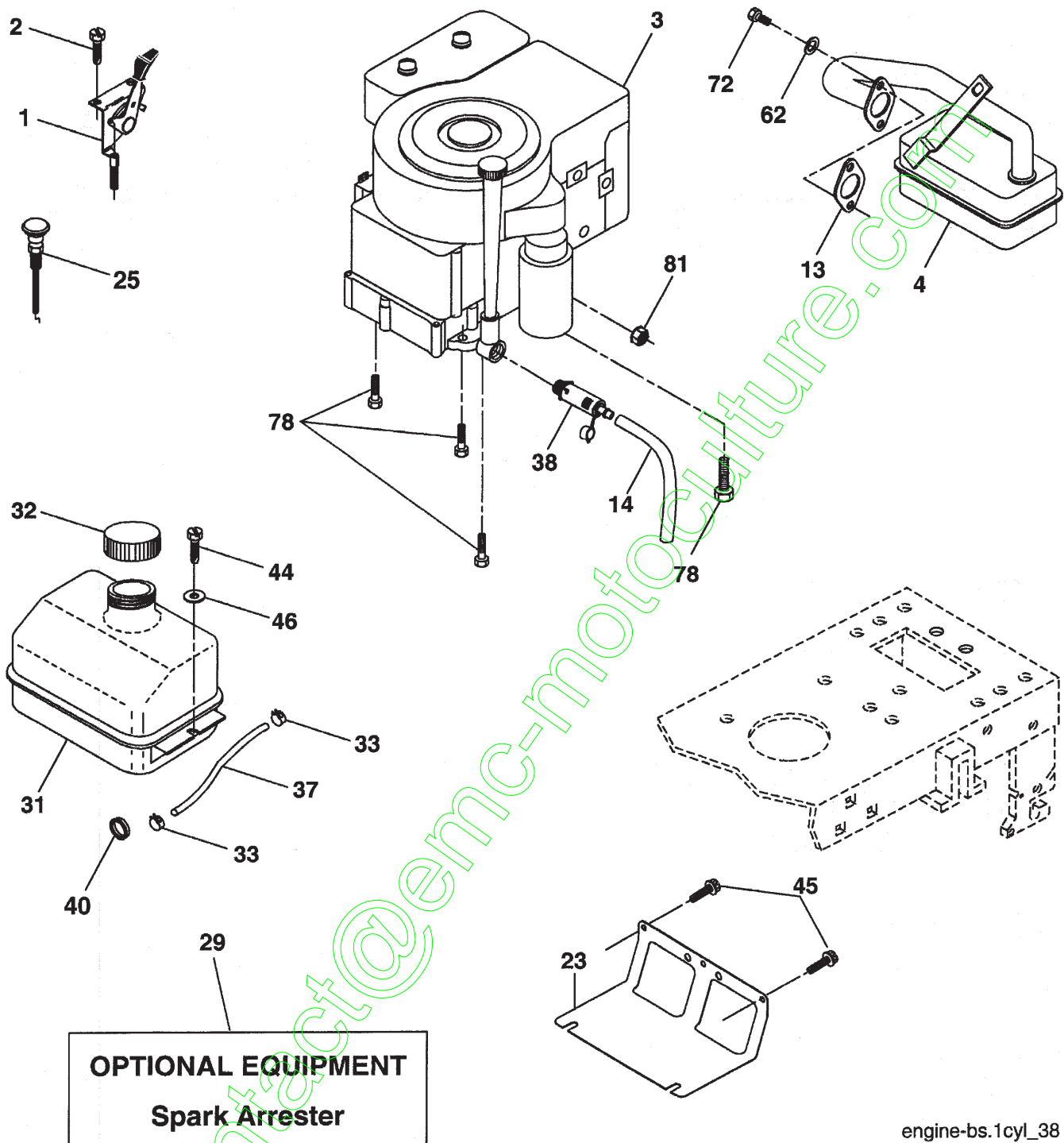

engine-bs.1cyl_38

REPAIR PARTS

TRACTOR- -MODEL NO. 917. 277331

ENGINE

KEY NO.	PART NO.	DESCRIPTION
1	170545	Control, Throttle
2	17720408	Screw, Hex Head, Thread Cutting, 1/4-20 x 5/8
3	-----	Engine, (See Breakdown) Briggs Model No. 280H07-0385-E1
4	137352	Muffler
13	165291	Gasket
14	148456	Tube Drain Oil Easy
23	169837	Shield Brn/Dbr Guard
25	187770X428	Control, Choke
29	137180	Arrestor, Spark
31	187750	Tank, Fuel
32	140527	Cap Assembly Fuel
33	123487X	Clamp, Hose
37	137040	Line, Fuel
38	181654	Plug, Drain Oil Easy
40	124028X	Bushing Snap
44	17670412	Screw, Hex Washer Head, Thd., Roll. 1/4-20 x 3/4
45	17000612	Screw Hex Wsh Thdr 3/8-16 x 3/4
46	19091416	Washer 9/32 x 7/8 x 16 Ga.
62	10010500	Washer Split
72	71070512	Screw Hex Hd Cap 5/16-18 x 3/4
78	17060620	Screw 3/8-16 x 1-1/4
81	73510400	Nut Keps Hex 1/4-20 unc

NOTE: All component dimensions given in U.S. inches 1 inch = 25.4 mm

REPAIR PARTS

TRACTOR- -MODEL NO. 917. 277331

MOWER LIFT

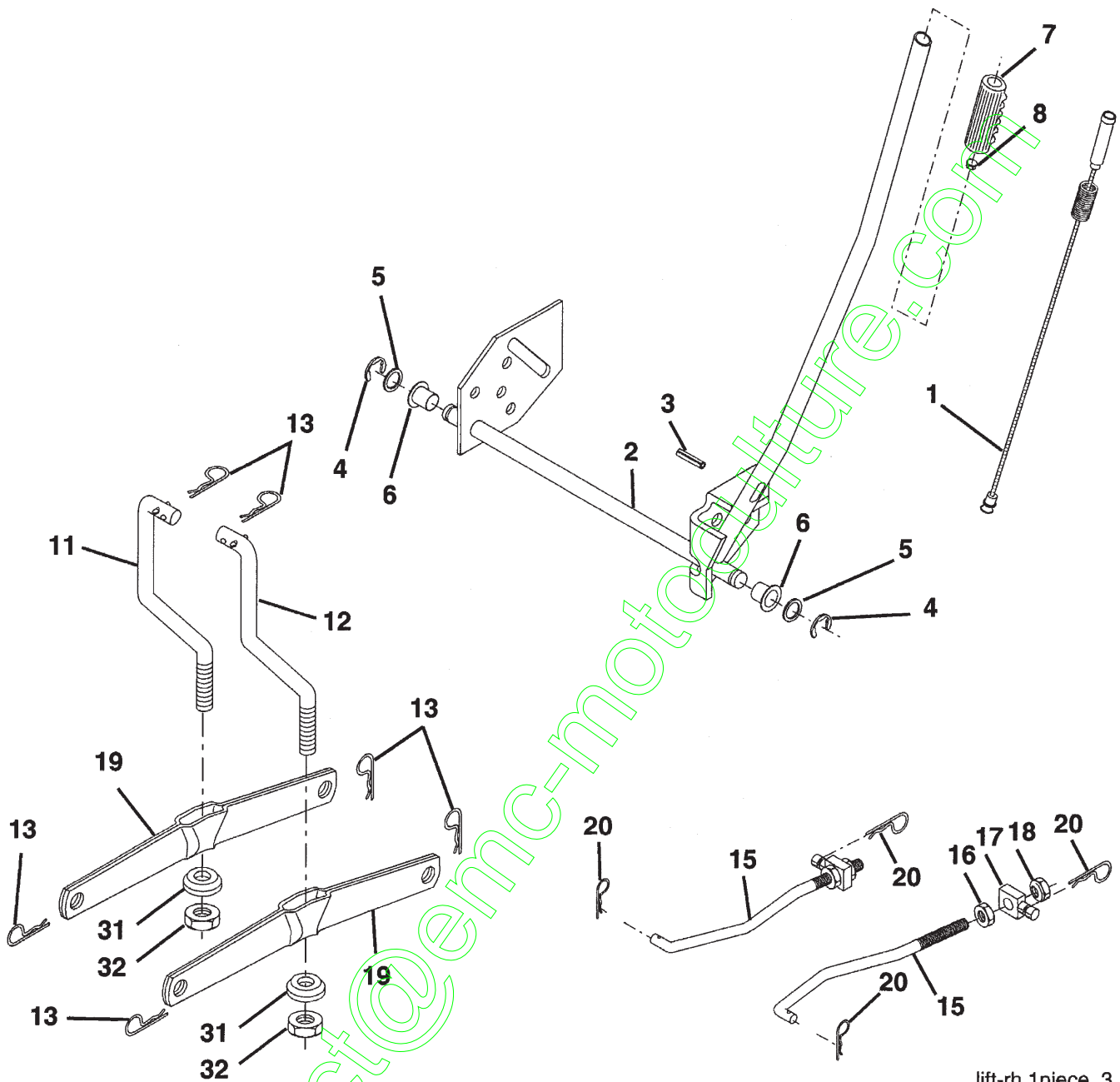

lift-rh.1piece_3

REPAIR PARTS

TRACTOR- -MODEL NO. 917. 277331

MOWER LIFT

KEY NO.	PART NO.	DESCRIPTION
1	159460	Lift Lever Inner Wire Assembly
2	159471	Shaft Assembly, Lift
3	105767X	Pin, Groove
4	12000002	E-Ring
5	19211621	Washer 21/32 x 1 x 21 Ga.
6	120183X	Bearing, Nylon
7	125631X	Grip, Handle, Fluted
8	122365X	Button, Plunger, Red
11	139865	Link, Lift, L.H.
12	139866	Link, Lift, R.H.
13	STD624008	Retainer Spring
15	173288	Link, Front
16	73350800	Nut, Hex, Jam 1/2-13 unc
17	175689	Trunnion
18	73800800	Locknut, Hex, with Washer Insert 1/2-13 unc
19	139868	Arm, Suspension, Rear
20	163552	Retainer Spring
31	169865	Bearing, Pvt, Lift
32	73540600	Nut, Crownlock 3/8-24

NOTE: All component dimensions given in U.S. inches
1 inch = 25.4 mm

REPAIR PARTS

TRACTOR- -MODEL NO. 917. 277331

MOWER

KEY NO.	PART NO.	DESCRIPTION	KEY NO.	PART NO.	DESCRIPTION
1	170280	Mower Housing Assembly	67	149846	Knob
2	72140506	Bolt, Carriage 5/16-18 x 3/4	68	180214	Belt
3	138017	Bracket Asm. Fram Sway Bar	86	7631J	Runner, LH
4	169970	Bracket, Asm. Deck Sway Bar	87	128772	Runner, RH
5	4939M	Retainer, Spring	88	19111216	Washer 11/32 x 3/4 x 16 Ga.
6	178024	Bar Sway Deck	89	19131311	Washer 13/32 x 13/16 x 11 Ga.
8	850857	Bolt, Hex 3/8-24 x 1-1/4 Gr. 8	96	74930620	Bolt 3/8-16 x 1-1/4
9	10030600	Washer, Lock, Hlcl Sprg 3/8	97	73930600	Nut Centerlock 3/8-16
10	140296	Washer, Hard Blade Mower Vented (The following blades are available)	98	19132016	Washer 13/32 x 1-1/4 x 16 Ga.
11	134148	Blade, 38" Mulching Std (For mulching mowers only)	99	10040600	Washer Lock Hvy Hlcl Spr. 3/8 Nut Wing
13	137645	Shaft and Bearing Assembly (In- cludes Key Number 15)	100	135651	Cover Asm Mulching 38"
14	128774	Mandrel Housing, Vented	101	132803	Spacer, Retainer
15	110485X	Ball Bearing, Mandrel	107	133502	Stiffener, Idler Arm
16	174493	Stripper, Mower, Vented	108	133503	Bolt, Hex Head 3/8-16 x2-1/2
19	132827	Bolt, Shoulder	109	74760640	Upstop Deck Front 38"
21	73680500	Nut, Crownlock 5/16-18	110	142587	Screw 5/16-18 x 3/4
23	137607	Bracket, Mower Deflector	113	17060512	Rod, Brake, LH
24	105304X	Cap, Sleeve	122	131289	Rod, Brake, RH
25	123713X	Spring, Deflector	123	169971	Bolt Carriage Idler
26	110452X	Nut, Push	146	165891	Spring Return Idler
27	106736X428	Shield, Deflector	148	169022	Retainer Spring Yellow Zinc
28	19111016	Washer 11/32 x 3/4 x 16 Ga.	149	165898	Washer 9/32 x 3/4 x 10 Ga.
29	106735X	Rod, Hinge	150	19091210	Cable Clutch 38 In
30	173984	Screw, Thdro	152	172758	Screw Hex Thd Cut 1/4-20 x 1/2
31	187690	Washer, Spacer	158	17720408	Head Asm. Cable Clutch
32	153532	Pulley, Mandrel	185	188234	Mandrel Assembly (Includes Hous- ing, Shaft and Shaft Hardware Only-Pulley Not Included)
33	178342	Nut, Flangelock 9/16	--	130794	Replacement Mower, Complete (Std. Deck - Order separately mulcher cover components key nos. 96-101)
36	131494	Pulley, Idler, Flat	--	181209	
40	73680600	Nut Crownlock 3/8-16			
45	4497H	Retainer, Spring			
53	130840	Brake Assembly			
54	178515	Washer Hardened			
55	133840	Idler Arm Assembly			
56	165723	Spacer, Retainer			

NOTE: All component dimensions given in U.S. inches
1 inch = 25.4 mm

REPAIR PARTS

TRACTOR- -MODEL NO. 917. 277331

DANA TRANSAXLE - MODEL NUMBER D4360-140

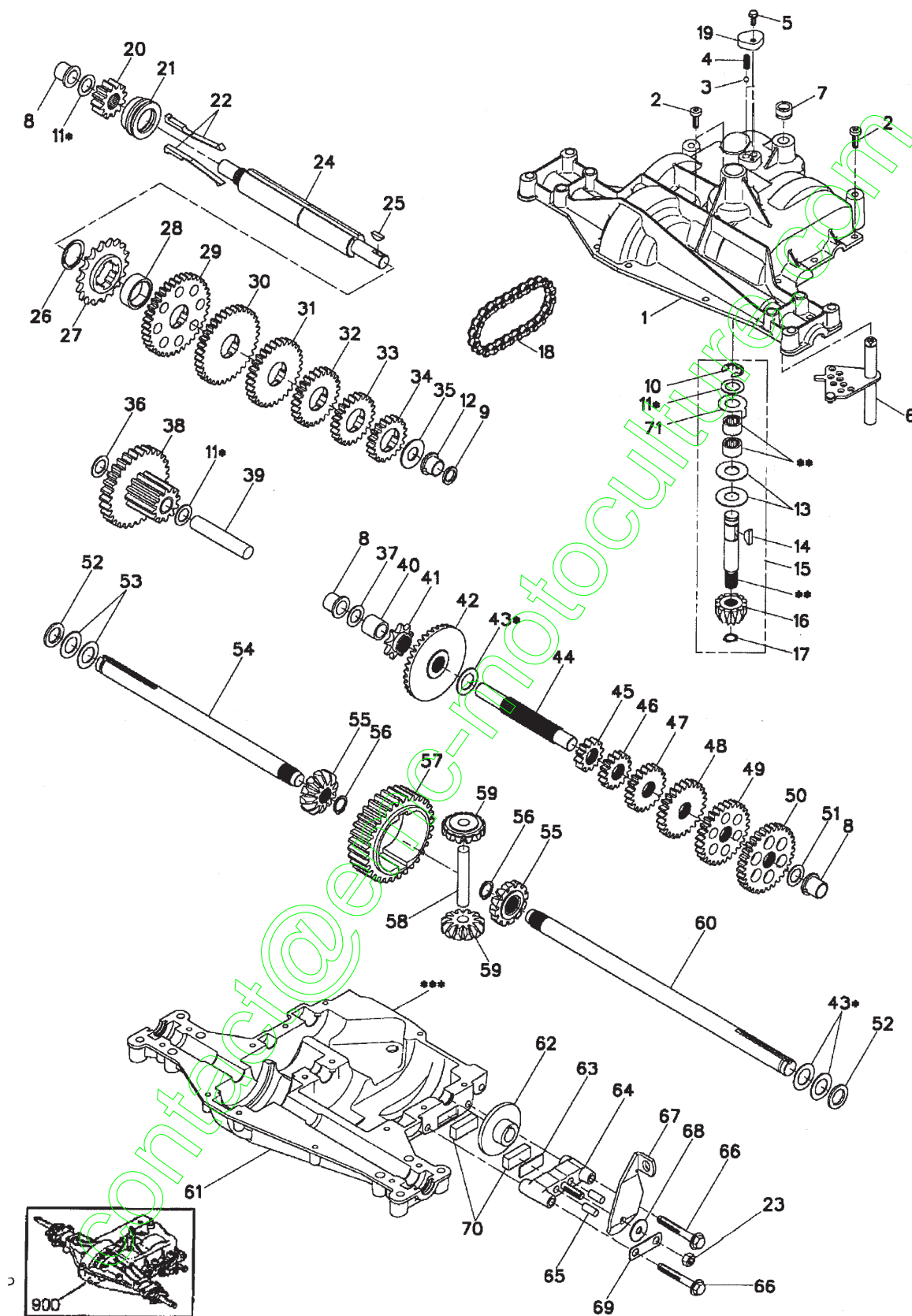

REPAIR PARTS

TRACTOR- -MODEL NO. 917. 277331

DANA TRANSAXLE - MODEL NUMBER D4360-140

KEY NO.	PART NO.	DESCRIPTION	KEY NO.	PART NO.	DESCRIPTION
1	170981	Housing, Upper	40	120472X	Spacer, .633 X .87 X .755
2	2274J	Screw, Tapping, 1/4-20 X .734	41	105928X	Sprocket, 9T
3	134400	Ball, Detent	42	170988	Gear, Bevel, 36T
4	105904X	Spring, Detent	43	134394	*Assy, Kit, Shim, .750 Shaft
5	160940	Screw, Tapping, No. 10-24 X .482	44	120473X	Shaft, Drive
6	138235	Assy, Kit, Shifter	45	142678	Gear, Spur, 12T
7	108727X	V-Ring	46	143697	Gear, Spur, 15T
8	148266	Bearing, Flange	47	124641X	Gear, Spur, 20T
9	148269	Seal, Oil	48	106589X	Gear, Spur, 25T
10	2225J	Ring, Retaining	49	120408X	Gear, Spur, 28T
11	134793	* Assy, Kit, Shim, .625 Shaft	50	105937X	Gear, Spur, 31T
12	148268	Bearing, Flange	51	2226J	Washer, Plain, .632 X 1.00 X .060
13	120415X	Washer, Plain, .632 X 1.38 X .046	52	134401	Washer, Neoprene
14	142674	Key, Woodruff, No. 9	53	2264J	Washer, Plain, .758 X 1.25 X .031
15	170983	Assy, Kit, Input Shaft	54	160946	Axle, LH
16	170986	Pinion, Bevel, 12T	55	170990	Gear, Miter, 1 2T, Splined
17	105909X	Ring, Retaining	56	160948	Ring, Retaining
18	105910X	Chain, 24 Pitches	57	110071X	Gear, Spur, 32T
19	160942	Cover, Detent	58	120952X	Shaft, Cross
20	160943	Gear, Spur, 1 2T	59	170991	Gear, Miter, 1 2T, Idler
21	148267	Collar, Clutch	60	160950	Axle, RH
22	138236	Assy, Kit, Clutch Keys	61	170992	Housing, Lower
23	73810500	Nut, Lock, 5/16-24	62	7294J	Disc, Brake
24	142676	Shaft, Intermediate	63	108989X	Spacer, Brake Puck
25	2244J	Key, Woodruff, No. 61	64	160952	Jaw, Brake
26	105916X	Ring, Retaining	65	120954X	Pin, Dowel
27	120470X	Sprocket, 1 8T	66	160953	Screw, Tapping, 5/16-18 X 2.35
28	110070X	Spacer, 1.131 X 1.45 X .494	67	138244	Lever, Actuating
29	142677	Gear, Spur, 37T	68	108996X	Washer, Plain, .321 X 1.00 X .055
30	142681	Gear, Spur, 35T	69	160954	Bracket, Anti-Rotation
31	124644X	Gear, Spur, 30T	70	120951X	Puck, Friction
32	108980X	Gear, Spur, 25T	71	174256	Washer, Anti Rotation
33	120406X	Gear, Spur, 22T	72	120416X	Grease
34	134796	Gear, Spur, 19T			
35	105925X	Washer, Plain, .640 X 1.37 X .061			
36	2228J	Washer, Plain, .632 X 1.00 X .046			
37	170987	Washer, Plain, .632 X 1.00 X .031			
38	174255	Assy, Gear, Comb., 12T & 30T			
39	124639X	Shaft, Idler			

NOTE: All component dimensions given in U.S. inches
1 inch = 25.4 mm

* Use in various combinations to maintain proper clearances.

** Order Key No. 15.

*** Silicone Sealant to be applied between Upper and Lower Housings (use Loctite Ultra Gray Silicone 5699 or equivalent).

REPAIR PARTS

TRACTOR- -MODEL NO. 917. 277331

BRIGGS & STRATTON ENGINE - - MODEL NUMBER 280H07, TYPE NUMBER 0385-E1

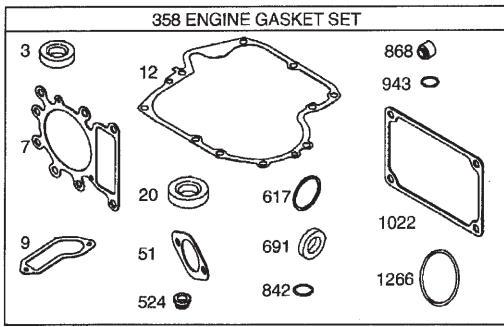

1019 LABEL KIT

1058 OWNER'S MANUAL

1036 EMISSION LABEL

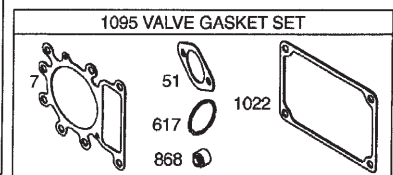
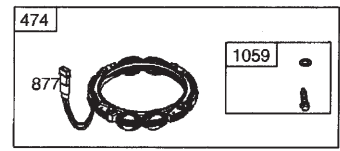
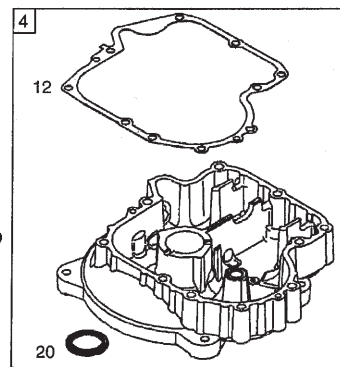
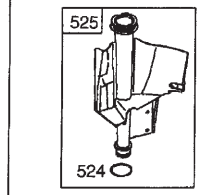
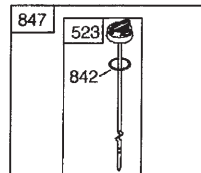
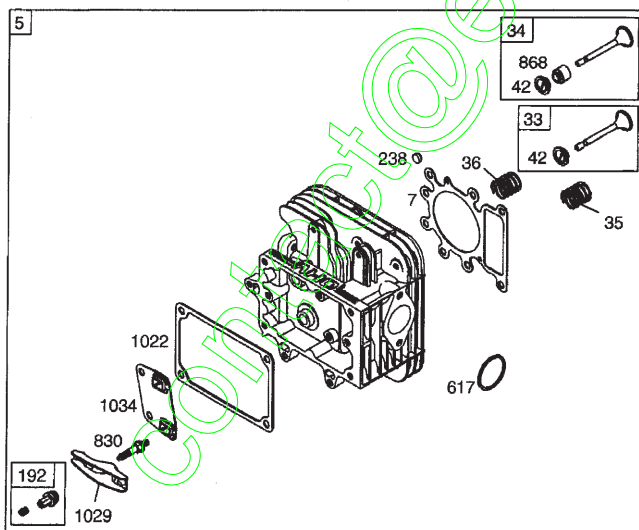
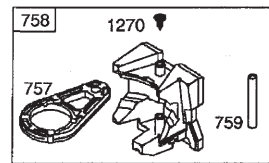
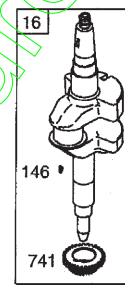
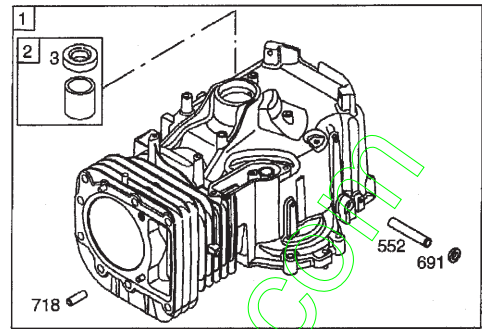
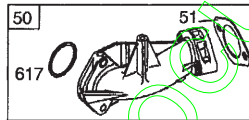
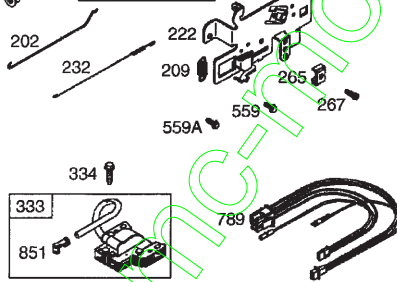
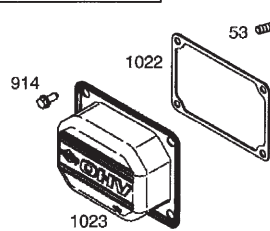
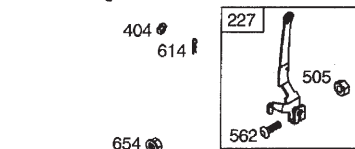
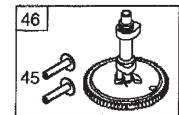
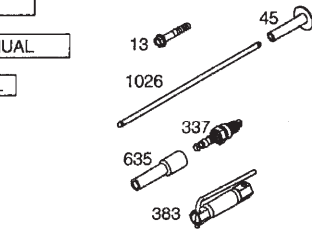
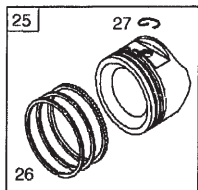

REPAIR PARTS

TRACTOR- -MODEL NO. 917. 277331

BRIGGS & STRATTON ENGINE - - MODEL NUMBER 280H07, TYPE NUMBER 0385-E1

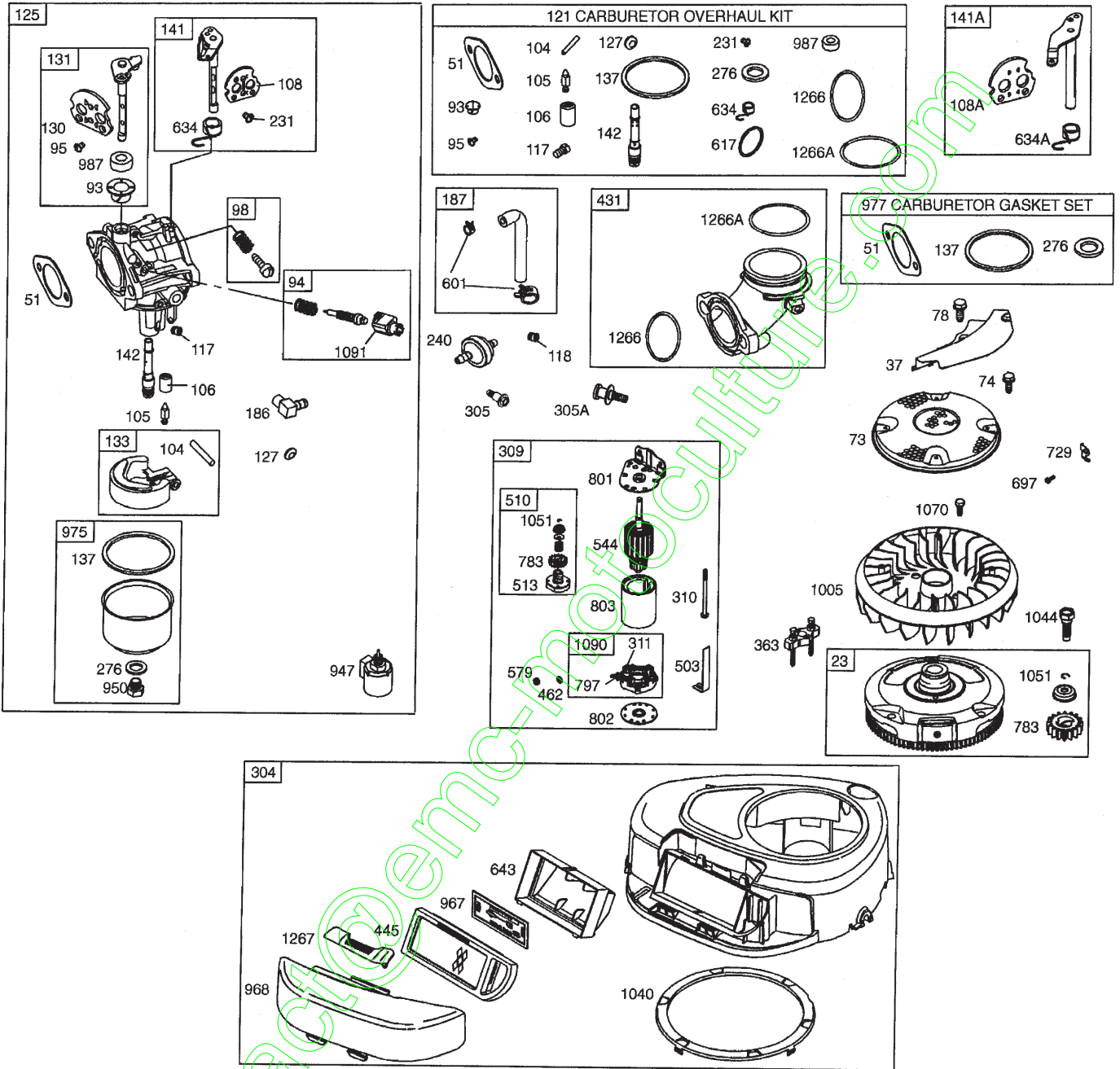

REPAIR PARTS

TRACTOR- -MODEL NO. 917. 277331

BRIGGS & STRATTON ENGINE - - MODEL NUMBER 280H07, TYPE NUMBER 0385-E1

KEY NO.	PART NO.	DESCRIPTION	KEY NO.	PART NO.	DESCRIPTION
1	697132	Cylinder Assembly	108A	692344	Valve-Choke (Choke A Matic)
2	399265	Kit-Bushing/Seal (Magneto Side)	117	694352	Ø Jet-Main (Standard)
3	391086	• Seal-Oil (Magneto Side)	118	697228	Jet-Main (High Altitude)
4	697106	Sump-Engine	121	697241	Kit-Carburetor Overhaul
5	698148	Head-Cylinder	125	698445	Carburetor
7	273280	•+ Gasket-Cylinder Head	127	695005	Plug-Welch
9	697109	• Gasket-Breather	130	691750	Valve-Throttle
10	697157	Screw (Breather Assembly)	131	494379	Kit-Throttle Shaft
11	697113	Tube-Breather	133	494381	Float-Carburetor
12	697110	• Gasket-Crankcase	137	281165	Ø‡ Gasket-Float Bowl
13	690360	Screw (Cylinder Head)	141	495097	Kit-Choke Shaft (Manual Choke)
15	690946	Plug-Oil Drain	141A	495931	Kit-Choke Shaft (Choke A Matic)
16	697127	Crankshaft	142	697140	Ø Nozzle-Carburetor
20	690947	• Seal-Oil (PTO Side)	146	691639	Key-Timing
22	692125	Screw (Crankcase Cover/Sump)	186	698174	Connector-Hose
23	693557	Flywheel	187	699331	Line-Fuel
24	222698	Key-Flywheel	188	691693	Screw (Control Bracket)
25	698371	Piston Assembly (Standard)	192	691986	Adjuster-Rocker Arm
--	698394	Piston Assembly (.020" Oversize)	202	691841	Link-Mechanical Governor
26	698375	Ring Set (Standard)	209	692208	Spring-Governor
--	698397	Ring Set (.020" Oversize)	222	694042	Bracket-Control
27	698469	Lock-Piston Pin	227	691374	Lever-Governor Control
28	697099	Pin-Piston	231	691636	Screw (Choke Valve)
29	697126	Rod-Connecting (Standard)	232	691842	Spring-Governor
32	692852	Screw (Connecting Rod)	238	691843	Cap-Valve
33	695760	Valve-Exhaust	240	394358	Filter-Fuel
34	695761	Valve-Intake	265	691024	Clamp-Casing
35	691279	Spring-Valve (Intake)	267	695134	Screw (Casing Clamp)
36	691279	Spring-Valve (Exhaust)	276	692255	Ø‡ Washer-Sealing
37	697352	Guard-Flywheel	304	698402	Housing-Blower
42	499586	Keeper-Valve	305	697102	Screw (Blower Housing)
43	691968	Slinger-Governor/Oil	305A	697103	Screw (Blower Housing)
45	690564	Tappet-Valve	306	697107	Shield-Cylinder
46	790400	Camshaft	307	691003	Screw (Cylinder Shield)
48	697761	Short Block	309	693551	Motor-Starter
50	690193	Manifold-Intake	310	690323	Bolt (Starter Motor)
51	692137	•Ø‡+ Gasket-Intake	311	497608	Brush Set
53	690227	Stud (Carburetor)	333	492341	Armature-Magneto
54	691148	Screw (Intake Manifold)	334	691061	Screw (Magneto Armature)
73	697384	Screen-Rotating	337	691043	Plug-Spark
74	697987	Screw (Rotating Screen)	358	697151	Gasket Set-Engine
78	691003	Screw (Flywheel Guard)	363	19203	Flywheel Puller
93	690602	Ø Bushing-Throttle Shaft	383	89838	Wrench-Spark Plug
94	498030	Kit-Idle Mixture			
95	691636	Screw (Throttle Valve)			
98	495800	Kit-Idle Speed			
104	690525	Ø Pin-Float Hinge			
105	231855	Ø Valve-Float Needle			
106	690577	Ø Seat-Inlet			
108	690464	Valve-Choke (Manual Choke)			

- Included in Engine Gasket Set, Key. No. 358
- Ø Included in Carburetor Overhaul Kit, Key. No. 121
- ‡ Included in Carburetor Gasket Set, Key. No. 977
- + Included in Valve Gasket Set, Key. No. 1095

NOTE: All component dimensions given in U.S. inches 1 inch = 25.4 mm

REPAIR PARTS

TRACTOR- -MODEL NO. 917. 277331

BRIGGS & STRATTON ENGINE - - MODEL NUMBER 280H07, TYPE NUMBER 0385-E1

KEY NO.	PART NO.	DESCRIPTION	KEY NO.	PART NO.	DESCRIPTION
404	691691	Washer (Governor Crank)	947	694393	Solenoid-Fuel
431	697122	Elbow-Intake	950	691657	Screw (Float Bowl)
445	698083	Filter-Air Cleaner Cartridge	967	697015	Filter-Pre Cleaner
462	691261	Washer (Starter Cable)	968	698403	Cover-Air Cleaner
474	696459	Alternator	975	495933	Bowl-Float
503	691532	Strap-Starter	977	690192	Gasket Set-Carburetor
505	691251	Nut (Governor Control Lever)	987	691326	Ø Seal-Throttle Shaft
510	693699	Drive-Starter	1005	699043	Fan-Flywheel
513	692024	Clutch-Drive	1019	697143	Kit-Label
523	699908	Dipstick	1022	272475	•+ Gasket-Rocker Cover
524	691032	• Seal-Dipstick Tube	1023	791079	Cover-Rocker Arm
525	697184	Tube-Dipstick	1026	692003	Rod-Push (Intake)
544	692034	Starter-Armature	-- --	692011	Rod-Push (Exhaust)
552	697144	Bushing-Governor Crank	1029	691751	Arm-Rocker
559	697561	Screw (Remote Choke)	1034	690822	Guide-Push Rod
559A	693675	Screw (Remote Choke)	1036	790464	Label-Emission
562	691119	Bolt (Governor Control Lever)	1040	698368	Plate-Trim
579	691029	Nut (Starter Cable)	1044	698139	Screw (Flywheel)
584	697112	Cover-Breather Passage	1051	691265	Ring-Retaining
601	95162	Clamp-Hose	1058	275038	Owner's Manual
614	691620	Pin-Cotter	1059	698516	Kit-Screw/Washer
616	692012	Crank-Governor	1070	690372	Screw (Flywheel Fan)
617	692138	Ø Seal-O Ring (Intake Manifold)	1090	691293	Retainer-Brush
634	690801	Ø Spring/Seal Assembly (Manual Choke)	1091	691333	Cap-Limiter
634A	690802	Ø Spring/Seal Assembly (Choke A Matic)	1095	691581	Gasket Set-Valve
635	691909	Boot-Spark Plug	1119	691183	Screw (Alternator)
643	698401	Retainer-Air Filter	1263	697124	Reed-Breather
654	690958	Nut (Carburetor)	1264	697104	Screw (Breather Reed)
691	692407	• Seal-Governor Shaft	1266	691917	•Ø Seal-O Ring (Intake Elbow)
697	690372	Screw (Drive Cap)	1266A	697123	Ø Seal-O Ring (Intake Elbow)
718	690959	Pin-Locating	1267	697419	Latch-Blower Housing
729	691224	Clip-Wire	1270	697156	Plug-AVS Counterweight
741	697128	Gear-Timing	1329	280H07-0036	Replacement Engine (Remove Choke Link-691840)(If the original engine is equipped with a six pin wiring harness transfer to the replacement engine)(Transfer the speed limiter control assembly to the replacement engine)(Transfer governor spring to the replacement engine)(Transfer muffler and/or spark arrester assembly from the original engine if suitable for additional service or add new parts as required)
757	697607	Link-Counterweight			
758	697134	Counterweight			
759	697392	Pin-Counterweight			
783	693713	Gear-Pinion			
789	698329	Harness-Wiring			
797	693167	Nut (Brush Retainer)			
801	691283	Cap-Drive			
802	691286	Cap-End			
803	693757	Housing-Starter			
830	691095	Stud (Rocker Arm)			
842	691031	• Seal-O Ring (Dipstick Tube)			
847	790442	Dipstick/Tube Assembly			
851	692424	Terminal-Spark Plug			
868	690968	•+ Seal-Valve			
877	393456	Wire-Connector/Alternator			
914	691108	Screw (Rocker Cover)			

- Included in Engine Gasket Set, Key. No. 358
- Ø Included in Carburetor Overhaul Kit, Key. No. 121
- ‡ Included in Carburetor Gasket Set, Key. No. 977
- + Included in Valve Gasket Set, Key. No. 1095

NOTE: All component dimensions given in U.S. inches 1 inch = 25.4 mm

SERVICE NOTES

contact@enc-motoculture.com

SERVICE NOTES

contact@enc-motoculture.com

LIMITED WARRANTY ON CRAFTSMAN RIDING EQUIPMENT

For two (2) years from the date of purchase, if this Craftsman Riding Equipment is maintained, lubricated and tuned up according to the instructions in the owner's manual, Sears will repair or replace free of charge any parts that are found to be defective in material or workmanship according to the guidelines of coverage listed below. Sears will also provide free labor for these applicable warranted parts for 2 full years. During the first 30 days of purchase, there will be no charges to service the product at your home for issues covered by this warranty. (See exclusions below). For your convenience, IN HOME warranty service will still be available after the first 30 days of purchase, but a trip charge will apply. This charge will be waived if the Craftsman product is dropped off at an authorized Sears location. For the nearest authorized Sears location, please call 1-800-4-MY-HOME®. This warranty applies only while this product is within the United States.

This Warranty does not cover:

- Expendable items which become worn during normal use, including but not limited to blades, spark plugs, air cleaners, belts, and oil filters.
- Standard Maintenance Servicing, oil changes, or tune-ups
- Tire replacement or repair caused by punctures from outside objects, such as nails, thorns, stumps, or glass.
- Repairs necessary because of operator abuse, including but not limited to, damage caused by towing objects beyond the capability of the riding equipment, impacting objects that bend the frame or crankshaft, or over-speeding the engine.
- Repairs necessary because of operator negligence, including but not limited to, electrical and mechanical damage caused by improper storage, failure to use the proper grade and amount of engine oil, failure to keep the deck clear of flammable debris, or failure to maintain the equipment according to the instructions contained in the owner's manual.
- Engine (fuel system) cleaning or repairs caused by fuel determined to be contaminated or oxidized (stale). In general, fuel should be used within 30 days of its purchase date.
- Normal deterioration and wear of the exterior finishes, or product label replacement.
- Riding equipment used for commercial or rental purposes.

LIMITED WARRANTY ON BATTERY

For ninety (90) days from date of purchase, if any battery included with this riding equipment proves defective in material or workmanship and our testing determines the battery will not hold a charge, Sears will replace the battery at no charge. During the first 30 days of purchase, there will be no charges to replace the battery at your HOME. After the first 30 days, for your convenience, IN-HOME warranty service will still be available but a trip charge will apply. This charge will be waived if the Craftsman product is dropped off at an authorized Sears location. For the nearest authorized Sears location, please call 1-800-4-MY-HOME®.

This battery warranty applies only while this product is within the United States.

This warranty gives you specific legal rights, and you may also have other rights, which vary, from state to state.

Sears, Roebuck and Co., Dept. 817WA, Hoffman Estates, IL 60179

CRAFTSMAN®