



PIECES DETACHEES

Motobineuse polyvalente

A280



Yvon Béal 21, Av. de l'Agriculture - B.P. 16
21, av. Brézet 63014 Clermont-Ferrand Cedex 2
Tel: 04 73 93 92 15 - Télécopie: 04 73 90 22 11
www.yvonbeal.fr Email: info@yvonbeal.fr
R.C. B 304 973 886 - SIREN 304 973 886

1300-098-0950-0 - fév 86 -

03-000233-050304

ENGINE
Moteur

TZ60H-AB02 (KT290)
for A280-2E40
pour

www.emc-motoculture.com

CONTENTS

ENGINE Moteur

for A280-2E40 pour

Fig. E-1	TZ60H-AB02(KT290).....	2
Fig. A-1	AIR CLEANER..... Filtre a air	7
Fig. C-1	CARBURETOR..... Carbureteur	8
Fig. M-1	MAGNETO..... Volant magnetique	10
Fig. R-1	RECOIL STARTER..... Lanceur	11

for A280-E40 pour

Fig. E-2	FA130G-AB03(FA130G-33X).....	14
Fig. A-2	AIR CLEANER..... Filtre a air	20
Fig. F-1	FILTER..... Robinet	21
Fig. C-2	CARBURETOR..... Carbureteur	22
Fig. R-2	RECOIL STARTER..... Lanceur	24

NOTE)

* Marked parts in the column remarks, are not always in stock, requiring considerable time for their delivery.

NOTA)

* Les pièces marquées dans la colonne des remarques, ne sont pas toujours disponibles en stock, et demandent beaucoup de temps avant de pouvoir être livrées.

Fig. E-1 TZ60H-AB02(KT290)

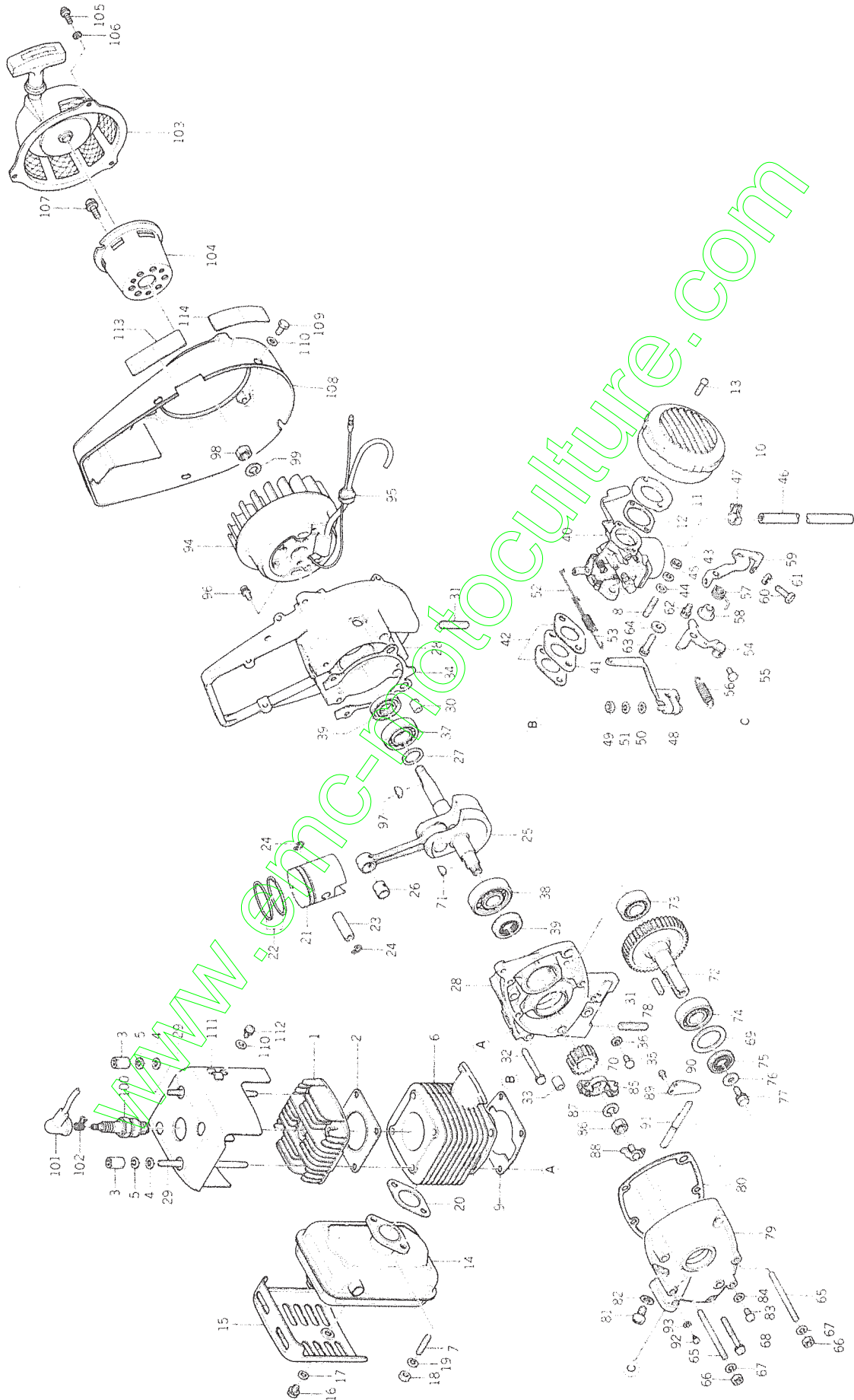

Ref. No. Réf. No.	Part No. Pièces No.	Description Désignation	Q'ty Quant.	Remarks Remarques	
1	5126-511-111-03	HEAD, CYL. Culasse	1	312651-1111-03	
2	5126-511-121-00	GASKET Joint de culasse	1	312651-1121-00	
3	5111-201-484-00	NUT Ecrou	4	311120-1484-00	
4	5410-B06-00X-XX	WASHER, PL/M6 Rondelle	4	410B0600	
5	5461-F06-00A-XX	WASHER, SP/M6 Rondelle frein	4	461F0600A	
6	5126-511-210-03	CYLINDER ASSY Cylindre	1	312651-1210-03	
7	5171-G06-18X-XX	•STUD/M6x18 Goujon	2	171G0618	
8	5171-G06-20X-XX	•STUD/M6x20 Goujon	2	171G0620	
9	5123-011-221-00	GASKET Joint de cylindre	1	312301-1221-00	
10	5126-961-310-BX	AIR CLEANER ASSY Filtre a air	1	312696-1310B	See Fig. A-1 Voir Fig. A-1
11	5126-961-331-AX	PIPE, INLET Pipe d'admission	1	312696-1331A	
12	5126-961-332-AX	GASKET Joint	1	312696-1332A	
13	5214-B04-18X-XX	SCREW/M4x18 Vis	2	214B0418	
14	5490-692-139-9Z	MUFFLER ASSY Silencieux	1	49069-2139-9Z	
15	5491-062-356-9Z	•COVER, MUFFLER Protecteur de silencieux	1	49106-2356-9Z	
16	5180-B06-08X-XX	•BOLT/M6x8 Vis	2	180B0608	
17	5410-B06-00X-XX	•WASHER, PL/M6 Rondelle	2	410B0600	
18	5311-B06-00X-XX	NUT/M6 Ecrou	2	311B0600	
19	5461-F06-00A-XX	WASHER, SP/M6 Rondelle frein	2	461F0600A	
20	5124-011-443-00	GASKET Joint	1	312401-1443-00	
21	5126-513-111-BX	PISTON Piston	1	312651-3111B	
22	5121-213-010-00	RING, PISTON SET Jeu de segments	1	312121-3010-00	
23	5128-013-121-AX	PIN, PISTON Axe de piston	1	312801-3121A	
24	5128-013-122-AX	RING, SNAP Collet d'axe	2	312801-3122A	
25	5126-903-210-AX	CRANK SHAFT ASSY Vilebrequin	1	312690-3210A	
26	5126-903-242-AX	•BUSH, SMALL Cousinnet	1	312690-3242A	
27	5123-013-232-00	SHIM/t=0.2 Cale	AR	312301-3232-00	
	5123-013-233-00	SHIM/t=0.4 Cale	AR	312301-3233-00	
	5123-013-234-00	SHIM/t=0.6 Cale	AR	312301-3234-00	
28	5126-514-110-06	CRANK CASE ASSY Carter moteur	1	312651-4110-06	
29	5126-514-117-00	•STUD Goujon	4	312651-4117-00	
30	5552-B10-12X-XX	•PIN, DOWEL Goupille elastique	2	552B1012	
31	5172-G08-18X-XX	•STUD/M8x18 Goujon	4	172G0818	
32	5232-B06-45X-XX	SCREW/M6x45 Vis	4	232B0645	
33	5552-B10-12X-XX	PIN, DOWEL Goupille elastique	2	552B1012	
34	5126-514-113-00	GASKET Joint de carter moteur	1	312651-4113-00	
35	5214-B06-10X-XX	SCREW/M6x10 Vis	1	214B0610	
36	5143-107-433-00	GASKET Joint	1	314310-7433-00	
37	5123-014-211-00	BEARING, RB/6203C ₃ Roulement	1	312301-4211-00	

TZ60H-AB02 (KT290)

Ref. No. Réf. No.	Part No. Pièces No.	Description Désignation	Q'ty Quant.	Remarks Remarques	
38	5123-014-212-00	BEARING, RB/6303C ₃ Roulement	1	312301-4212-00	
39	5123-014-232-00	SEAL, OIL Bague d'étanchéité	2	312301-4232-00	
40	5150-012-489-XX	CARBURETOR ASSY Carburateur	1	15001-2489	See Fig. C-1 Voir Fig. C-1
41	5126-516-181-BX	INSULATOR Isolateur	1	312651-6181B	
42	5123-026-186-00	GASKET Joint	2	312302-6186-00	
43	5312-B06-00X-XX	NUT/M6 Ecrou	2	312B0600	
44	5410-B06-00X-XX	WASHER, PL/M6 Rondelle	2	410B0600	
45	5461-F06-00A-XX	WASHER, SP/M6 Rondelle frein	2	461F0600A	
46	5702-A05-100-0X	TUBE/ø=180mm Tuyau	1	702A051000	
47	5920-372-137-XX	CLAMP Collier	1	92037-2137	
48	5126-515-211-00	ARM, GOVERNOR Bras de regulateur	1	312651-5211-00	
49	5311-B06-00X-XX	NUT/M6 Ecrou	1	311B0600	
50	5410-B06-00X-XX	WASHER, PL/M6 Rondelle	1	410B0600	
51	5461-F06-00A-XX	WASHER, SP/M6 Rondelle frein	1	461F0600A	
52	5126-515-231-00	LINK, GOVERNOR Timonerie de regulateur	1	312651-5231-00	
53	5126-515-232-00	SPRING, LINK R ressort de timonerie	1	312651-5232-00	
54	5126-515-310-00	CONTROL LEVER ASSY Lever	1	312651-5310-00	
55	5112-B05-10X-XX	BOLT/M5x10 Vis	1	112B0510	
56	5126-515-314-00	SPRING, GOVERNOR R ressort de regulateur	1	312651-5314-00	
57	5126-515-317-BX	SPRING, RETURN R ressort der	1	312651-5317B	
58	5122-005-319-00	COLLAR Collier	1	312200-5319-00	
59	5126-515-335-00	BRACKET Support	1	312651-5335-00	
60	5112-B06-16X-XX	BOLT/M6x16 Vis	1	112B0616	
61	5312-B06-00X-XX	NUT/M6 Ecrou	1	312B0600	
62	5232-B06-10X-XX	SCREW/M6x10 Vis	1	232B0610	
63	5232-B06-25X-XX	SCREW/M6x25 Vis	1	232B0625	
64	5117-023-591-00	WASHER Rondelle	1	311702-3591-00	
65	5126-514-171-00	STUD Goujon	2	312651-4171-00	
66	5311-B06-00X-XX	NUT/M6 Ecrou	2	311B0600	
67	5461-F06-00A-XX	WASHER, SP/M6 Rondelle frein	2	461F0600A	
68	5232-B06-45X-XX	SCREW/M6x45 Vis	3	232B0645	
69	5124-533-534-00	SHIM/t=0.2 Cale	AR	312453-3534-00	
	5124-533-535-00	SHIM/t=0.4 Cale	AR	312453-3535-00	
	5124-533-536-00	SHIM/t=0.6 Cale	AR	312453-3536-00	
70	5126-513-523-00	GEAR, PINION Pignon	1	312651-3523-00	
71	5126-513-321-00	KEY Clavette	1	312651-3321-00	
72	5126-513-520-00	SHAFT ASSY Arbre a cames	1	312651-3520-00	
73	5601-A62-02X-XX	BEARING, RB/6202 Roulement	1	601A6202	
74	5601-A62-03X-XX	BEARING, RB/6203 Roulement	1	601A6203	

TZ60H-AB02 (KT290)

Ref. No. Réf. No.	Part No. Pièces No.	Description Désignation	Q'ty Quant.	Remarks Remarques	
75	5123-034-242-00	SEAL, OIL Bague d'étanchéité	1	312303-4242-00	
76	5122-005-383-00	WASHER, COLLAR Rondelle	1	312200-5383-00	
77	5180-B06-16X-XX	BOLT/M6x16 Vis	1	180B0616	
78	5511-A05-20X-XX	KEY Clavette	1	511A0520	
79	5126-513-512-00	CASE, REDUCER Carter de reducteur	1	312651-3512-00	
80	5126-513-516-00	GASKET Joint	1	312651-3516-00	
81	5214-B08-10X-XX	SCREW/M8x10 Vis	1	214B0810	
82	5123-007-432-00	GASKET Joint	1	312300-7432-00	
83	5214-B06-10X-XX	SCREW/M6x10 Vis	2	214B0610	
84	5143-107-433-00	GASKET Joint	2	314310-7433-00	
85	5126-515-110-00	GOVERNOR ASSY Regulateur	1	312651-5110-00	
86	5315-G10-00X-XX	NUT/M10 Ecrou	1	315G1000	
87	5461-F10-00A-XX	WASHER, SP/M10 Rondelle frein	1	461F1000A	
88	5126-515-121-00	SLEEVE, GOVERNOR Butée de regulateur	1	312651-5121-00	
89	5126-515-122-00	TIP, GOVERNOR Palpeur de regulateur	1	312651-5122-00	
90	5232-B04-06A-XX	SCREW/M4x6 Vis	2	232B0406A	
91	5126-515-123-00	SHAFT, GOVERNOR Axe de regulateur	1	312651-5123-00	
92	5126-715-124-00	SCREW Vis	1	312671-5124-00	
93	5461-F04-00X-XX	WASHER, SP/M4 Rondelle frein	1	461F0400	
94	5126-518-110-00	MAGNETO ASSY Volant magnetique	1	312651-8110-00	See Fig. M-1 Voir Fig. M-1
95	5123-018-164-00	GROMMET Bougie	1	312301-8164-00	
96	5234-B05-14A-XX	SCREW/M5x14 Vis	2	234B0514A	
97	5510-A32-00X-XX	KEY Clavette	1	510A3200	
98	5315-G10-00X-XX	NUT/M10 Ecrou	1	315G1000	
99	5461-F10-00A-XX	WASHER, SP/M10 Rondelle frein	1	461F1000A	
100	5122-008-410-00	PLUG, SPARK/NGK B6HS Bougie	1	312200-8410-00	
101	5115-098-418-02	CAP, PLUG Contacteur de bougie	1	311509-8418-02	
102	5115-098-419-BX	SPRING Ressort	1	311509-8419B	
103	5490-882-285-ZM	RECOIL STARTER ASSY Lanceur complet	1	49088-2285-ZM	See Fig. R-1 Voir Fig. R-1
104	5490-802-128-XX	PULLEY Bol	1	49080-2128	
105	5214-B06-10X-XX	SCREW/M6x10 Vis	3	214B0610	
106	5461-F06-00A-XX	WASHER, SP Rondelle frein	3	461F0600A	
107	5232-B06-10X-XX	SCREW/M6x10 Vis	3	232B0610	
108	5590-662-148-ZM	CASE, SPIRAL Volute	1	59066-2148-ZM	
109	5180-B06-12X-XX	BOLT/M6x12 Vis	4	180B0612	
110	5410-B06-00X-XX	WASHER, PL/M6 Rondelle	6	410B0600	
111	5126-961-632-AX	COVER, CYL. Couvre culasse	1	312696-1632A	
112	5232-B06-10X-XX	SCREW/M6x10 Vis	2	232B0610	
113	5126-920-852-BX	LABEL Etiquette	1	312692-0852B *	

Ref. No. Réf. No.	Part No. Pièces No.	Description Désignation	Q'ty Quant.	Remarks Remarques
114	5123-AA0-814-AX	LABEL Etiquette	1	3123AA-0814A ※
	ACCESSORY Accessoire			
	5126-900-900-00	TOOL ASSY Outillage complet	1	312690-0900-00
	5131-220-942-01	• WRENCH, PLUG/M21 Cle a tube	1	313122-0942-01
	5112-200-972-00	• GAUGE, THICKNESS Jauge d'epaisseur	1	311220-0972-00

Fig. A-1

AIR CLEANER
Filtre a air

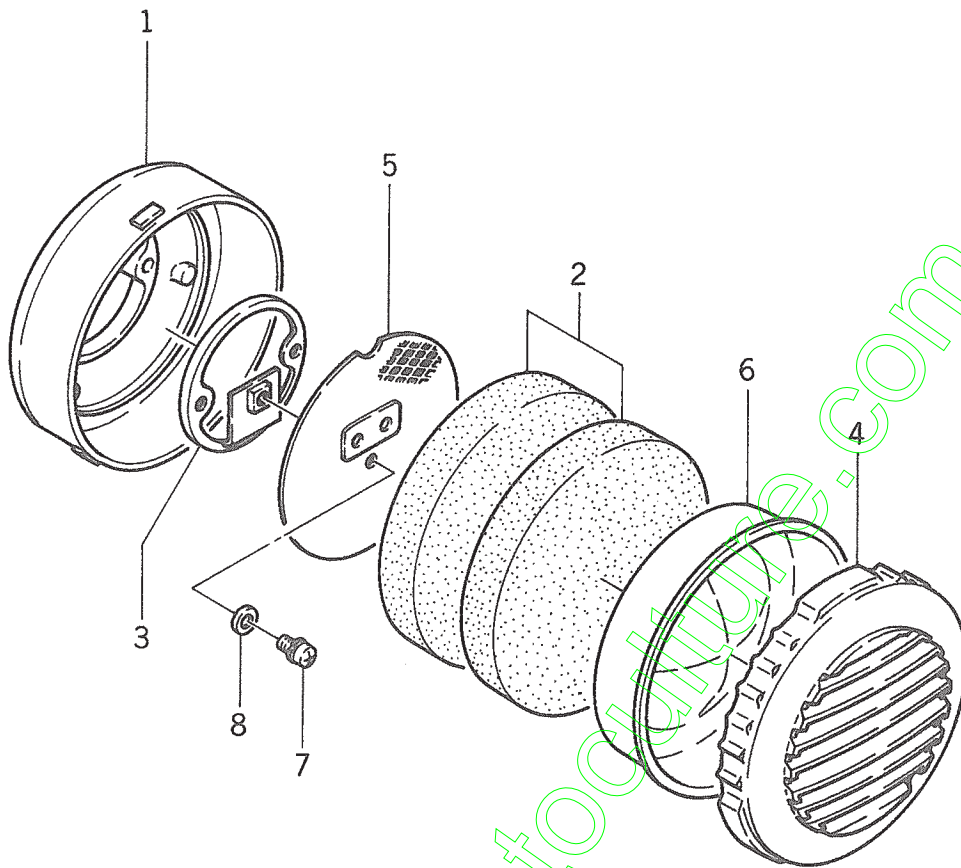

Ref. No. Réf. No.	Part No. Pièces No.	Description Désignation	Q'ty Quant.	Remarks Remarques
	5126-961-310-BX	AIR CLEANER ASSY Filtre a air	1	312696-1310B
A-1- 1	5126-961-311-AX	•CASE, CLEANER Carenage	1	312696-1311A
A-1- 2	5111-781-312-00	•ELEMENT Cartouche	2	311178-1312-00
A-1- 3	5125-661-313-00	•PLATE, CLEANER Embase	1	312566-1313-00
A-1- 4	5111-781-316-00	•CAP, CLEANER Couvercle	1	311178-1316-00
A-1- 5	5126-961-318-AX	•SCREEN Filtre	1	312696-1318A
A-1- 6	5125-111-367-00	•HOLDER, ELEMENT Support	1	312511-1367-00
A-1- 7	5232-B04-08X-XX	•SCREW/M4x8 Vis	1	232B0408
A-1- 8	5410-B04-00X-XX	•WASHER, PL/M4 Rondelle	1	410B0400

Fig. C-1

CARBURETOR
Carbureteur

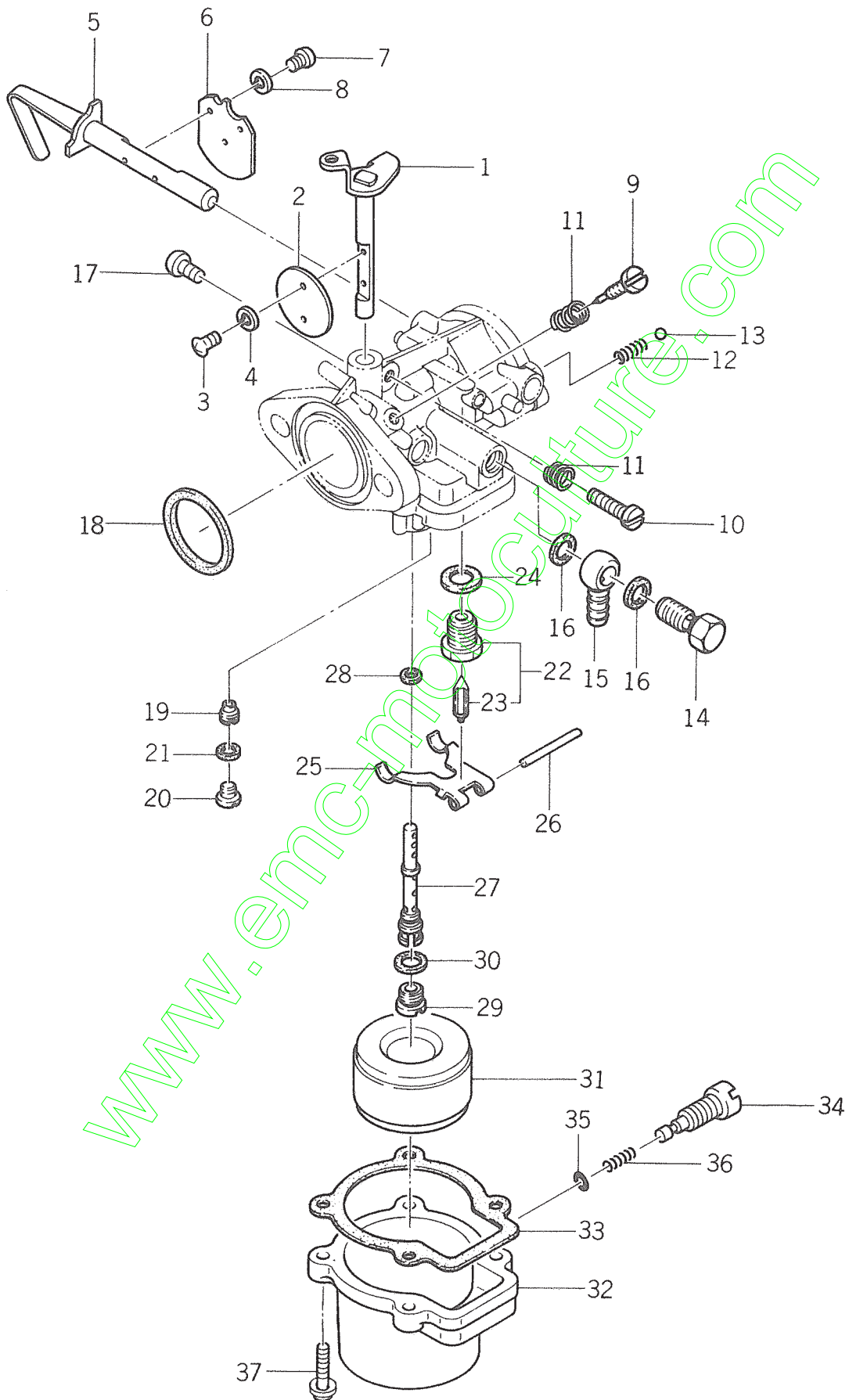
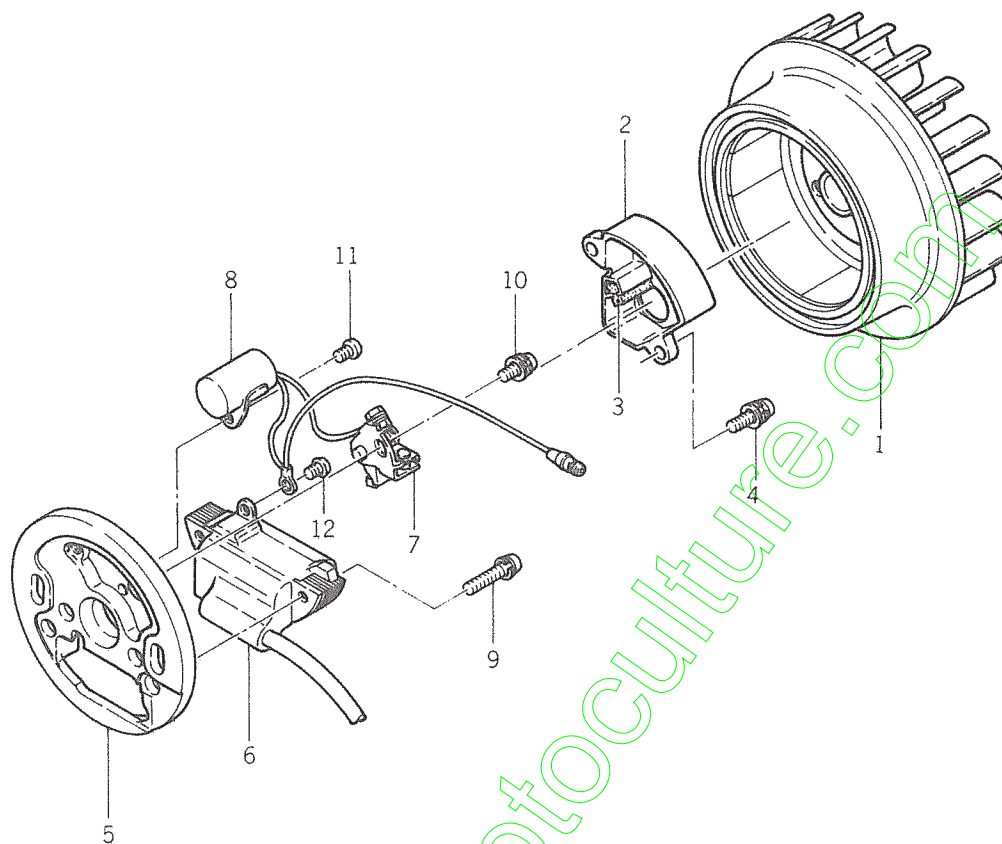

Fig. C-1 CARBURETOR
Carburateur

Ref. No. Réf. No.	Part No. Pièces No.	Description Désignation	Q'ty Quant.	Remarks Remarques
	5150-012-489-XX	CARBURETOR ASSY Ensemble carburateur	1	15001-2489
C-1- 1	5126-966-139-AX	•SHAFT, THROTTLE Axe papillon	1	312696-6139A
C-1- 2	5160-252-082-XX	•VALVE, THROTTLE Papillon	1	16025-2082
C-1- 3	5122-106-137-10	•SCREW Vis	2	312210-6137-10
C-1- 4	5122-106-138-00	•WASHER, SPRING Rondelle frein	2	312210-6138-00
C-1- 5	5126-966-142-AX	•SHAFT, CHOKE Axe volet d'air	1	312696-6142A
C-1- 6	5126-966-102-AX	•VALVE, CHOKE Volet d'air	1	312696-6102A
C-1- 7	5122-106-137-10	•SCREW Vis	2	312210-6137-10
C-1- 8	5122-106-138-00	•WASHER, SPRING Rondelle frein	2	312210-6138-00
C-1- 9	5126-516-114-00	•SCREW Vis	1	312651-6114-00
C-1-10	5124-016-115-10	•SCREW, STOP Vis de butée	1	312401-6115-10
C-1-11	5124-016-116-00	•SPRING Ressort	2	312401-6116-00
C-1-12	5122-106-123-00	•SPRING Ressort	1	312210-6123-00
C-1-13	5122-106-134-00	•BALL, STEEL Bille	1	312210-6134-00
C-1-14	5122-106-135-00	•BOLT, BANJO Vis, banjo	1	312210-6135-00
C-1-15	5122-106-136-00	•JOINT, BANJO Joint, banjo	1	312210-6136-00
C-1-16	5122-106-118-00	•GASKET Joint	2	312210-6118-00
C-1-17	5124-376-114-10	•SCREW, GUIDE Vis, guide	1	312437-6114-10
C-1-18	5134-396-159-00	•GASKET Joint	1	313439-6159-00
C-1-19	5126-516-151-00	•JET, SLOW/#46 Gicleur	1	312651-6151-00
C-1-20	5124-376-117-10	•SCREW, PILOT Vis de ralenti	1	312437-6117-10
C-1-21	5113-906-149-00	•GASKET Joint	1	311390-6149-00
C-1-22	5126-516-120-AX	•NEEDLE VALVE ASSY Ensemble pointeau	1	312651-6120A
C-1-23	5124-016-122-00	•VALVE, NEEDLE Pointeau	1	312401-6122-00
C-1-24	5113-906-119-00	•GASKET Joint	1	311390-6119-00
C-1-25	5124-016-178-00	•HINGE, FLOAT Charnière	1	312401-6178-00
C-1-26	5113-906-127-00	•PIN, FLOAT Axe	1	311390-6127-00
C-1-27	5124-016-129-00	•NOZZLE, MAIN Gicleur	1	312401-6129-00
C-1-28	5111-206-119-00	•GASKET Joint	1	311120-6119-00
C-1-29	5118-016-132-BX	•JET, MAIN/#90 Gicleur	1	311801-6132B
C-1-30	5126-516-149-00	•GASKET Joint	1	312651-6149-00
C-1-31	5124-016-126-00	•FLOAT Flotteur	1	312401-6126-00
C-1-32	5160-202-084-XX	•CHAMBER, FLOAT Cuve	1	16020-2084
C-1-33	5110-092-402-XX	•GASKET Joint	1	11009-2402
C-1-34	5920-092-222-XX	•SCREW, DRAIN Bouchon de vidange	1	92009-2222
C-1-35	5920-552-077-XX	•O-RING Joint torique	1	92055-2077
C-1-36	5921-442-013-XX	•SPRING Ressort	1	92144-2013
C-1-37	5232-B04-16X-XX	•SCREW/M4x16 Vis	4	232B0416

Fig. M-1

MAGNETO
Volant magnetique

Ref. No. Réf. No.	Part No. Pièces No.	Description Désignation	Q'ty Quant.	Remarks Remarques
	5126-518-110-00	MAGNETO ASSY Volant magnetique	1	312651-8110-00
M-1- 1	5126-518-111-00	• FLYWHEEL Volant d'inertie	1	312651-8111-00
M-1- 2	5126-518-439-00	• COVER, BREAKER Couverture de rupteur	1	312651-8439-00
M-1- 3	5126-518-451-00	• FELT, CAM Felt	1	312651-8451-00
M-1- 4	5126-518-448-00	• SCREW Vis	2	312651-8448-00
M-1- 5	5126-518-120-00	• BASE ASSY Plateau	1	312651-8120-00
M-1- 6	5126-518-123-00	• COIL, IGNITION Bobine d'induction	1	312651-8123-00
M-1- 7	5126-518-440-00	• BREAKER, CONTACT Rupteur	1	312651-8440-00
M-1- 8	5126-518-436-00	• CONDENSER Condensateur	1	312651-8436-00
M-1- 9	5126-518-128-00	• SCREW Vis	2	312651-8128-00
M-1-10	5124-804-06A-XX	• SCREW Vis	1	21480406A
M-1-11	5131-228-448-00	• SCREW Vis	1	313122-8448-00
M-1-12	5126-518-141-00	• SCREW Vis	1	312651-8141-00

Fig. R-1

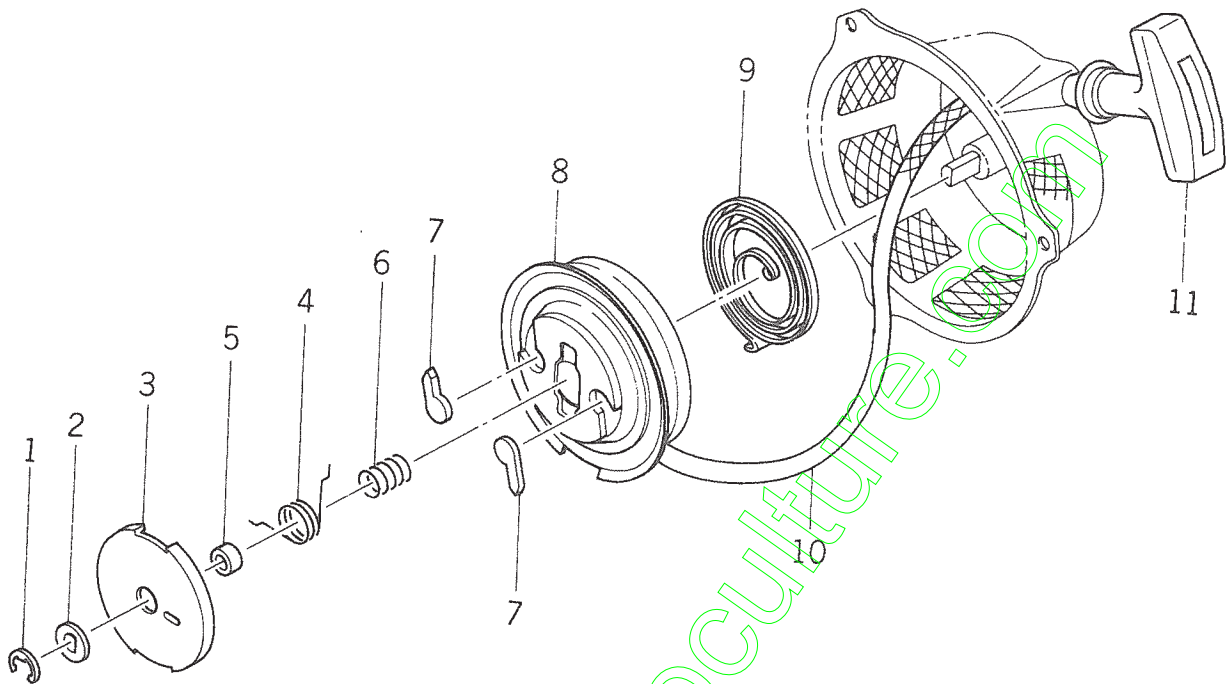
RECOIL STARTER
Lanceur

Ref. No. Réf. No.	Part No. Pièces No.	Description Désignation	Qty Quant.	Remarks Remarques
	5490-882-285-ZM	RECOIL STARTER ASSY Lanceur complet	1	49088-2285-ZM
R-1- 1	5123-003-451-00	•E-RING Bague en E	1	312300-3451-00
R-1- 2	5123-003-442-00	•WASHER Rondelle	1	312300-3442-00
R-1- 3	5123-993-449-00	•RETAINER Plaque de frein	1	312399-3449-00
R-1- 4	5124-993-448-00	•SPRING Ressort	1	312499-3448-00
R-1- 5	5123-003-458-00	•WASHER Rondelle	1	312300-3458-00
R-1- 6	5123-003-446-00	•SPRING Ressort	1	312300-3446-00
R-1- 7	5131-652-065-XX	•PAWL, RECOIL Cliquet	2	13165-2065
R-1- 8	5591-012-071-XX	•REEL, RECOIL Poulie	1	59101-2071
R-1- 9	5123-003-452-00	•SPRING, SPIRAL Ressort de frottement	1	312300-3452-00
R-1-10	5591-062-089-XX	•ROPE Cordon	1	59106-2089
R-1-11	5460-752-064-XX	•GRIP, RECOIL Poignée	1	46075-2064

ENGINE
Moteur

FA130G-AB03 (FA130G-33X)
for A280-E40
pour

www.emc-motoculture.com

Fig. E-2

FA130G-AB03(FA130G-33X)

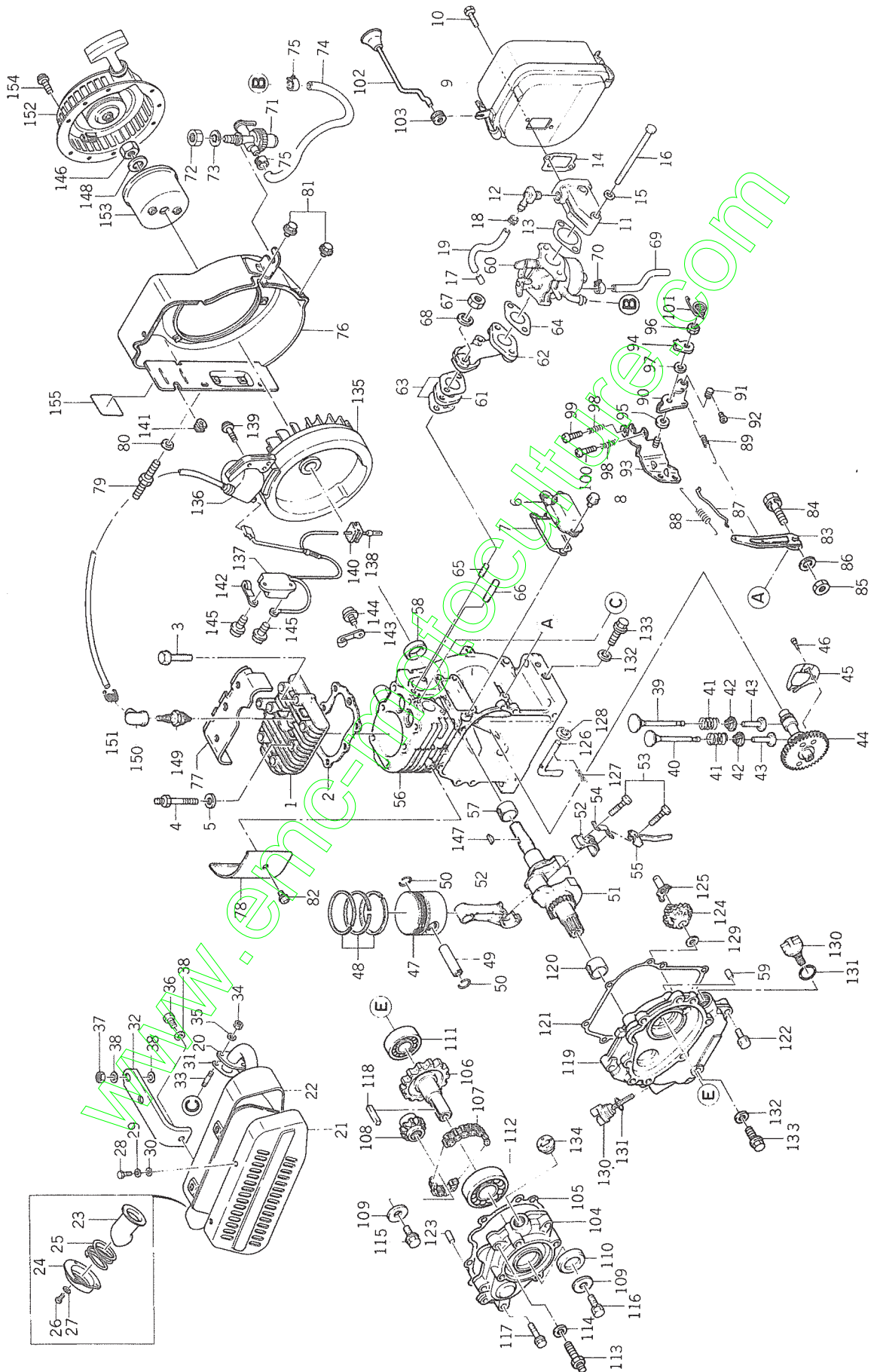

Ref. No. Réf. No.	Part No. Pièces No.	Description Désignation	Q'ty Quant.	Remarks Remarques
1	5144-011-111-AX	HEAD, CYL. Culasse	1	314401-1111A
2	5110-042-090-XX	GASKET, HEAD Joint	1	11004-2090
3	5181-608-50X-XX	BOLT/M8x50 Vis	1	18160850
4	5144-061-181-AX	BOLT Vis	6	314406-1181A
5	5410-B08-00X-XX	WASHER, PL/M8 Rondelle	6	410B0800
6	5491-082-070-XX	COVER, INSPECTION Porte de vis ite	1	49108-2070
7	5144-011-232-AX	GASKET Joint	1	314401-1232A
8	5186-B06-12X-XX	BOLT/M6x12 Vis	3	186B0612
9	5110-102-287-XX	AIR CLEANER ASSY Filtre a air	1	11010-2287
10	5144-131-316-AX	BOLT Vis	2	314413-1316A
11	5145-951-331-BX	PIPE, INLET Pipe d'admission	1	314595-1331B
12	5127-691-533-BX	ELBOW Coude	1	312769-1533B
13	5145-991-332-BX	GASKET Joint	1	314599-1332B
14	5145-951-332-AX	GASKET Joint	1	314595-1332A
15	5155-047-447-AX	GASKET Joint	2	315504-7447A
16	5110-B06-90X-XX	BOLT/M6x90 Vis	2	110B0690
17	5144-011-341-AX	PIPE Raccord	1	314401-1341A
18	5136-791-532-00	CLIP Clip	1	313679-1532-00
19	5702-A07-100-0X	TUBE, RUBBER/ $\varnothing=124mm$ Tuyau	1	702A071000
20	5490-696-019-XX	MUFFLER ASSY Silencieux	1	49069-6019
21	5491-062-334-9X	•COVER, MUFFLER Protecteur	1	49106-2334-9X
22	5491-062-331-9X	•COVER, MUFFLER Protecteur	1	49106-2331-9X
23	5158-221-449-AX	•PIPE, TAIL Tube d'echappement	1	315822-1449A
24	5131-692-446-9X	•PLATE Flasque	1	13169-2446-9X
25	5144-061-455-AX	•SPRING Ressort	1	314406-1455A
26	5144-053-092-AX	•SCREW Vis	3	314405-3092A
27	5410-B04-00X-XX	•WASHER Rondelle	3	410B0400
28	5110-R06-10X-XX	•BOLT/M6x10 Vis	4	110R0610
29	5461-F06-00A-XX	•WASHER, SPRING Rondelle frein	4	461F0600A
30	5411-B06-00X-XX	•WASHER Rondelle	4	411B0600
31	5144-961-442-BX	GASKET Joint	1	314496-1442B
32	5350-112-116-XX	STAY, MUFFLER Tirant	1	35011-2116
33	5171-G06-16X-XX	STUD Goujon	2	171G0616
34	5311-B06-00X-XX	NUT/M6 Ecrou	2	311B0600
35	5410-B06-00X-XX	WASHER Rondelle	2	410B0600
36	5180-B08-16X-XX	BOLT/M8x16 Vis	1	180B0816
37	5311-B08-00A-XX	NUT/M8 Ecrou	2	311B0800A
38	5411-B08-00X-XX	WASHER Rondelle	5	411B0800
39	5144-002-111-AX	VALVE, INLET Soupape adm.	1	314400-2111A

See Fig. A-2
Voir Fig. A-2

Ref. No. Réf. No.	Part No. Pièces No.	Description Désignation	Q'ty Quant.	Remarks Remarques	
40	5144-012-112-AX	VALVE, EXHAUST Soupape éch.	1	314401-2112A	
41	5144-012-113-AX	SPRING Ressort	2	314401-2113A	
42	5144-012-116-BX	RETAINER Plaquette frein	2	314401-2116B	
43	5144-012-211-AX	TAPPET Poussoir	2	314401-2211A	
44	5491-182-051-XX	GEAR, CAM A. C.	1	49118-2051	
45	5211-182-051-XX	•DECOMPRESSOR Decompresseur	1	21118-2051	
46	5920-432-105-XX	•PIN Axe	2	92043-2105	
47	5144-013-111-AX	PISTON Piston	1	314401-3111A	
48	5144-013-010-AX	PISTON RING SET Segmentation	1	314401-3010A	
49	5144-013-121-AX	PIN, PISTON Axe de piston	1	314401-3121A	
50	5144-013-122-AX	RING, SNAP Collet d'axe	2	314401-3122A	
51	5130-372-286-XX	SHAFT, CRANK Vile brequin	1	13037-2286	
52	5144-013-240-AX	CONN. ROD ASSY Bielle	1	314401-3240A	
53	5144-013-245-AX	•BOLT, CONN. ROD Vis	2	314401-3245A	
54	5144-013-248-AX	WASHER, LOCK Rondelle	1	314401-3248A	
55	5144-013-249-CX	ARM, SPLASHER Bras de manivelle	1	314401-3249C	
56	5491-206-004-XX	CRANK CASE ASSY Carter	1	49120-6004	
57	5144-014-211-AX	•BEARING, PLAIN Coussinet de palier	1	314401-4211A	
58	5142-504-231-00	SEAL, OIL Bague d'étancheité	1	314250-4231-00	
59	5551-A06-12X-XX	PIN, DOWEL Goupille elastique	2	551A0612	
60	5150-012-491-XX	CARBURETOR ASSY Carburateur	1	15001-2491	See Fig. C-2 Voir Fig. C-2
61	5144-016-181-AX	INSULATOR Isolateur	1	314401-6181A	
62	5144-826-182-AX	PIPE, INLET Pipe d'admission	1	314482-6182A	
63	5144-016-184-AX	GASKET Joint	2	314401-6184A	
64	5155-996-185-AX	GASKET Joint	1	315599-6185A	
65	5171-G06-22X-XX	STUD Goujon	1	171G0622	
66	5171-G06-35X-XX	STUD Goujon	1	171G0635	
67	5311-B06-00X-XX	NUT/M6 Ecrou	2	311B0600	
68	5411-B06-00X-XX	WASHER Rondelle	2	411B0600	
69	5920-592-191-XX	TUBE Conduit	1	92059-2191	
70	5114-096-812-00	CLIP Agrafe	1	311409-6812-00	
71	5136-506-510-02	FILTER ASSY Ensemble robinet	1	313650-6510-02	See Fig. F-1 Voir Fig. F-1
72	5136-506-527-00	NUT Ecrou	1	313650-6527-00	
73	5411-B10-00X-XX	WASHER Rondelle	1	411B1000	
74	5705-A04-100-0X	TUBE, BRAID/ø=156mm Tuyau	1	705A041000	
75	5136-791-532-00	CLIP Clip	2	313679-1532-00	
76	5590-662-348-ZM	CASE, SPIRAL Volute	1	59066-2348-ZM	
77	5490-892-208-ZM	COVER, CYL. HEAD Couvre culasse	1	49089-2208-ZM	
78	5144-011-632-AX	COVER, CYL. Couvre cyl.	1	314401-1632A	

Ref. No. Réf. No.	Part No. Pièces No.	Description Désignation	Q'ty Quant.	Remarks Remarques
79	5144-911-681-CX	BOLT Vis	1	314491-1681C
80	5411-B06-00X-XX	WASHER Rondelle	1	411B0600
81	5186-B06-10X-XX	BOLT/M6x10 Vis	4	186B0610
82	5241-B05-10X-XX	SCREW/M5x10 Vis	1	241B0510
83	5144-825-210-AX	ARM, GOVERNOR Bras	1	314482-5210A
84	5110-B06-25X-XX	•BOLT/M6x25 Vis	1	110B0625
85	5311-B06-00X-XX	•NUT/M6 Erou	1	311B0600
86	5411-B06-00X-XX	•WASHER Rondelle	1	411B0600
87	5144-825-231-AX	LINK, GOVERNOR Bras	1	314482-5231A
88	5144-995-232-AX	SPRING, LINK Ressort	1	314499-5232A
89	5144-915-314-AX	SPRING Ressort	1	314491-5314A
90	5144-915-311-BX	LEVER, CONTROL Levier	1	314491-5311B
91	5920-152-120-XX	NUT Erou	1	92015-2120
92	5214-B04-08X-XX	SCREW/M4x8 Vis	1	214B0408
93	5110-442-063-XX	BRACKET Support	1	11044-2063
94	5144-915-337-AX	BRACKET Support	1	314491-5337A
95	5144-015-383-AX	WASHER Rondelle	1	314401-5383A
96	5144-015-385-AX	NUT Erou	1	314401-5385A
97	5144-015-388-AX	SPRING Ressort	1	314401-5388A
98	5144-015-321-BX	SPRING Ressort	2	314401-5321B
99	5214-B04-20A-XX	SCREW/M4x20 Vis	1	214B0420A
100	5214-B04-25X-XX	SCREW/M4x25 Vis	1	214B0425
101	5144-065-317-AX	SPRING, RETURN Ressort de rappel	1	314406-5317A
102	5161-692-085-XX	LINK Timonerie	1	16169-2085
103	5171-965-515-00	GROMMET Bague de passage	1	317196-5515-00
104	5144-153-511-AX	CASE, REDUCER Boîtier de reducteur	1	314415-3511A
105	5144-153-515-AX	GASKET Joint	1	314415-3515A
106	5144-193-521-AX	SHAFT, DRIVE Arbre d'entraînement	1	314419-3521A
107	5144-153-526-BX	CHAIN Chaîne	1	314415-3526B
108	5144-153-671-BX	SPROCKET Pignon a chaîne	1	314415-3671B
109	5132-522-383-00	WASHER Rondelle	2	313252-2383-00
110	5164-704-231-00	SEAL, OIL Bague d'étanchéité	1	316470-4231-00
111	5601-A62-04X-XX	BEARING, RB/6204 Roulement	1	601A6204
112	5601-A63-05X-XX	BEARING, RB/6305 Roulement	1	601A6305
113	5146-214-166-AX	BOLT Vis	4	314621-4166A
114	5411-B06-00X-XX	WASHER Rondelle	4	411B0600
115	5181-B08-16X-XX	BOLT/M8x16 Vis	1	181B0816
116	5183-B08-25X-XX	BOLT/M8x25 Vis	1	183B0825
117	5186-B06-30X-XX	BOLT/M6x30 Vis	2	186B0630

FA130G-AB03 (FA130G-33X)

Ref. No. Réf. No.	Part No. Pièces No.	Description Désignation	Q'ty Quant.	Remarks Remarques	
118	5511-A05-20X-XX	KEY Clavette	1	511A0520	
119	5490-156-013-XX	SIDE BASE ASSY Flasque	1	49015-6013	
120	5144-014-211-AX	BEARING, PLAIN Coussinet de palier	1	314401-4211A	
121	5144-014-124-AX	GASKET Joint	1	314401-4124A	
122	5186-B06-30X-XX	BOLT/M6x30 Vis	6	186B0630	
123	5551-A06-12X-XX	PIN, DOWEL Goupille elastque	2	551A0612	
124	5144-015-110-AX	GOVERNOR ASSY Regulateur	1	314401-5110A	
125	5144-015-121-BX	SLEEVE, GOVERNOR Guidage d'entraineur	1	314401-5121B	
126	5144-015-122-CX	ARM, GOVERNOR Bras de réglage	1	314401-5122C	
127	5554-A06-00X-XX	PIN, SNAP Attache beta	1	554A0600	
128	5410-B06-00X-XX	WASHER Rondelle	1	410B0600	
129	5144-015-135-AX	WASHER Rondelle	1	314401-5135A	
130	5161-152-069-XX	GAUGE, OIL Jauge	2	16115-2069	
131	5670-B20-15X-XX	O-RING Joint torique	2	670B2015	
132	5145-V27-214-AX	GASKET Joint	3	3145V2-7214A	
133	5130-D10-14X-XX	BOLT/M10x14 Vis	3	130D1014	
134	5145-987-431-AX	PLUG, OIL Bouchon de remplissage	1	314598-7431A	
135	5144-AA8-111-AX	FLYWHEEL Rotor	1	3144AA-8111A	
136	5211-712-114-XX	IGNITION COIL Bobine d'allum.	1	21171-2114	
137	5144-AA8-465-AX	IGNITER Allumage	1	3144AA-8465A	
138	5144-AA8-812-AX	WIRE, LEAD Fil	1	3144AA-8812A	
139	5131-B05-20X-XX	BOLT/M5x20 Vis	2	131B0520	
140	5144-018-164-BX	GROMMET Passe-fil	1	314401-8164B	
141	5920-712-113-XX	GROMMET Passe-fil	1	92071-2113	
142	5920-372-171-XX	CLAMP Collier	1	92037-2171	
143	5117-028-161-00	CLAMP Collier	1	311702-8161-00	
144	5241-B04-08X-XX	SCREW/M4x8 Vis	1	241B0408	
145	5234-B05-14A-XX	SCREW/M5x14 Vis	2	234B0514A	
146	5314-G14-00X-XX	NUT/M14 Erou	1	314G1400	
147	5136-502-371-00	KEY Clavette	1	313650-2371-00	
148	5144-013-482-AX	WASHER Rondelle	1	314401-3482A	
149	5144-918-410-AX	PLUG, SPARK/NGK BM4A Bougie	1	314491-8410A	
150	5172-708-418-BX	CAP, PLUG Capuchon	1	317270-8418B	
151	5172-708-419-AX	SPRING Ressort	1	317270-8419A	
152	5490-882-286-ZM	RECOIL STARTER ASSY Lanceur complet	1	49088-2286-ZM	See Fig. R-2 Voir Fig. R-2
153	5490-802-108-XX	PULLEY Boi	1	49080-2108	
154	5186-B06-10X-XX	BOLT/M6x10 Vis	3	186B0610	
155	5154-830-851-BX	LABEL Etiquettes	1	315483-0851B *	

Ref. No. Réf. No.	Part No. Pièces No.	Description Désignation	Q'ty Quant.	Remarks Remarques
	ACCESSORY Accessoire			
	5144-900-931-AX	WRENCH, SOCKET/19x21	1	314490-0931A #
	5151-200-945-00	Cle tube BAR Levier	1	315120-0945-00 #

www.emc-motoculture.com

Fig. A-2 AIR CLEANER
Filtre a air

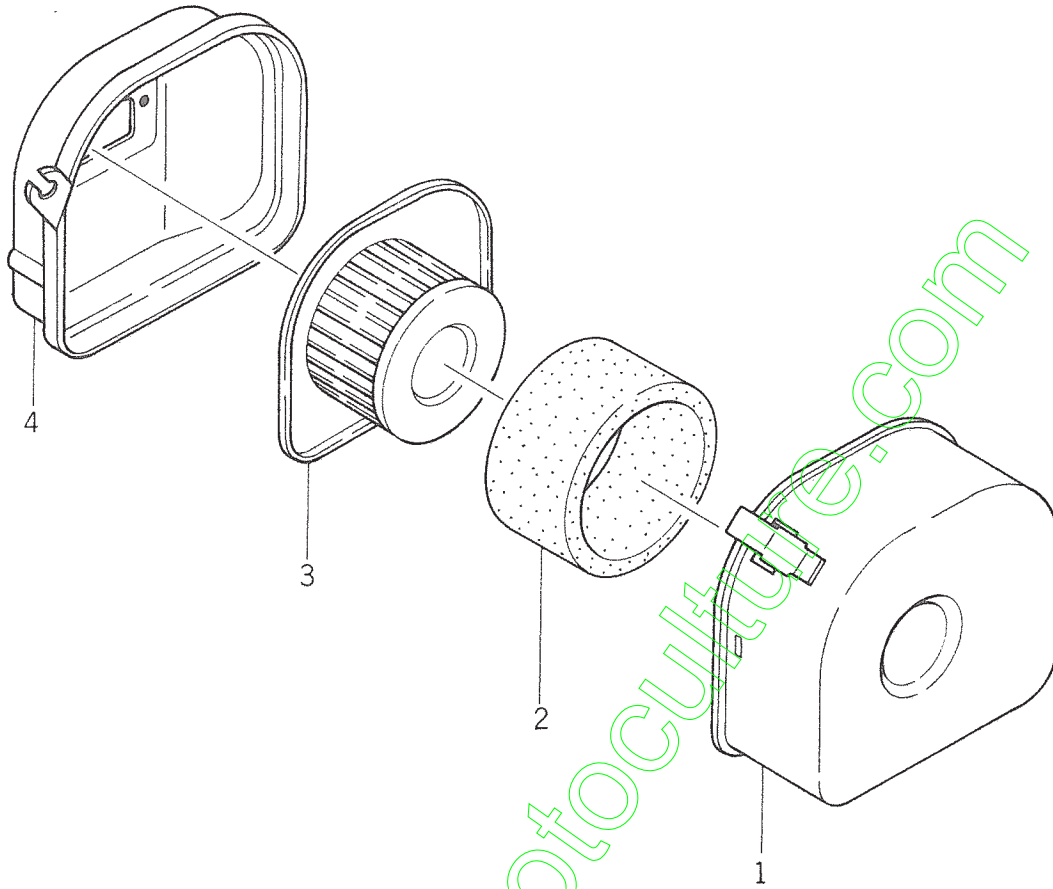

Ref. No. Réf. No.	Part No. Pièces No.	Description Désignation	Q'ty Quant.	Remarks Remarques
	5110-102-287-XX	AIR CLEANER ASSY Filtre a air	1	11010-2287
A-2- 1	5110-122-213-XX	•COVER, AIR CLEANER Cloche	1	11012-2213
A-2- 2	5155-101-313-AX	•ELEMENT Cartouche	1	315510-1313A
A-2- 3	5155-101-312-AX	•ELEMENT Cartouche	1	135510-1312A
A-2- 4	5320-992-118-XX	•PLATE, AIR CLEANER Grille	1	32099-2118

Fig. F-1 FILTER
Robinet

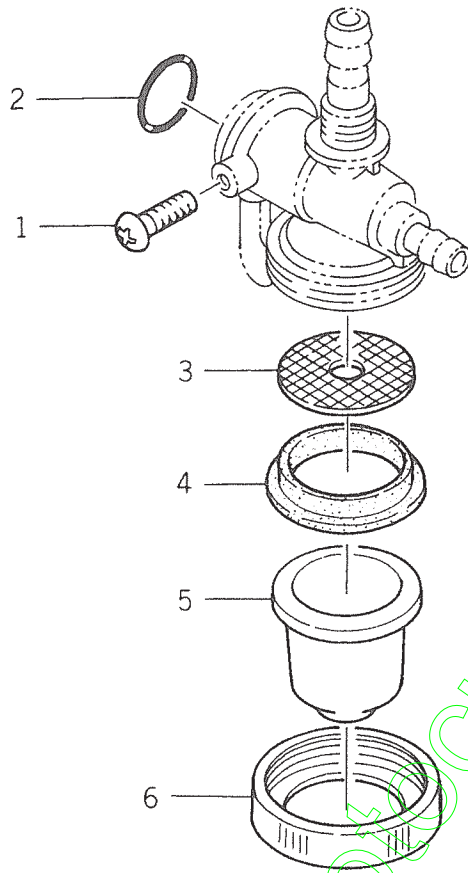

Ref. No. Réf. No.	Part No. Pièces No.	Description Désignation	Q'ty Quant.	Remarks Remarques
	5136-506-510-02	FILTER ASSY Ensemble robinet	1	313650-6510-02
F-1- 1	5136-506-517-00	•SCREW Vis	1	313650-6517-00
F-1- 2	5136-506-512-00	•O-RING Joint torique	1	313650-6512-00
F-1- 3	5136-506-519-00	•STRAINER, FILTER Filtre	1	313650-6519-00
F-1- 4	5136-506-518-02	•GASKET Joint	1	313650-6518-02
F-1- 5	5136-506-521-00	•POT, FILTER Cuve	1	313650-6521-00
F-1- 6	5136-506-522-00	•NUT, RING Bague filetée	1	313650-6522-00

Fig. C-2

CARBURETOR
Carbureteur

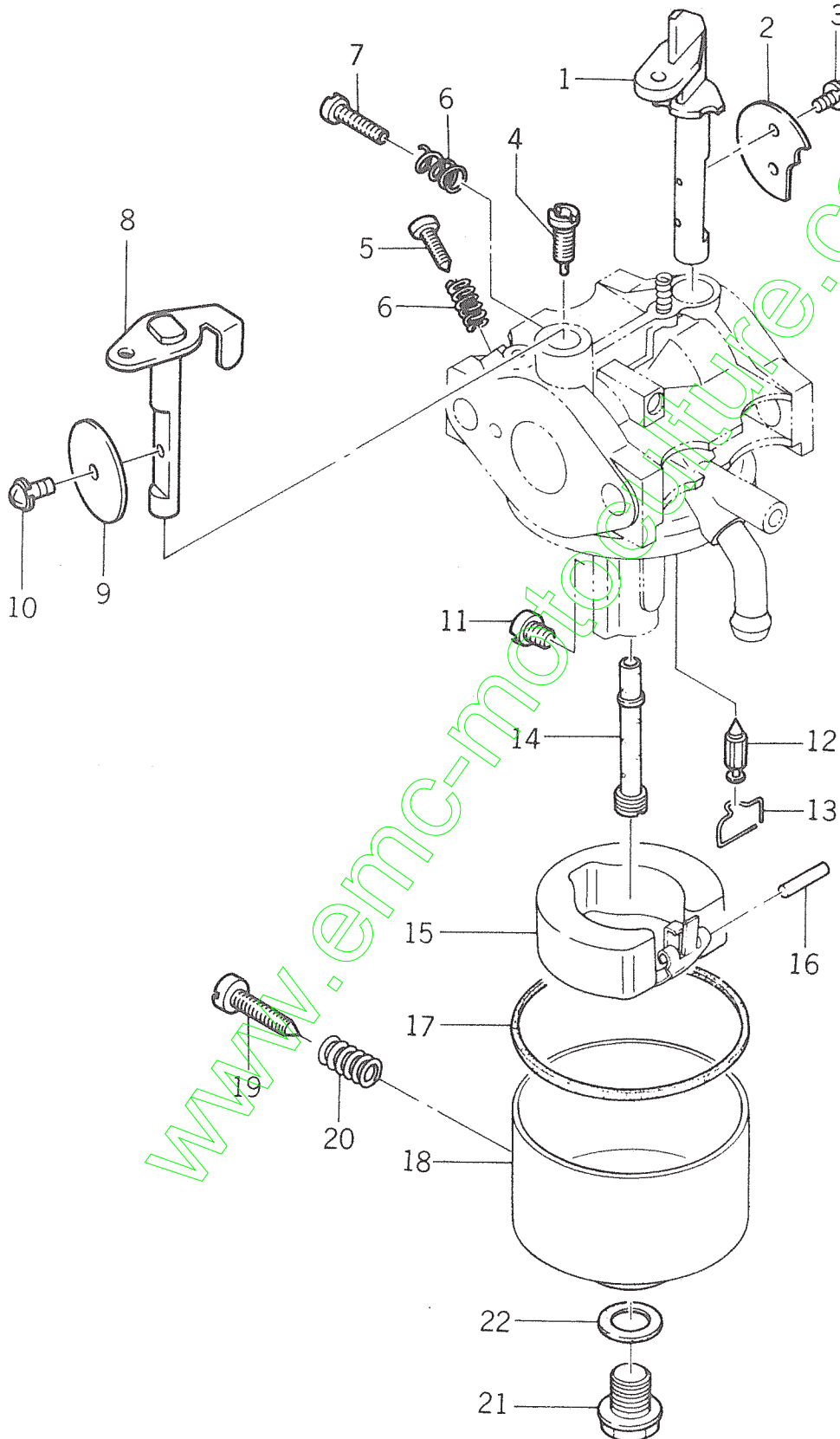
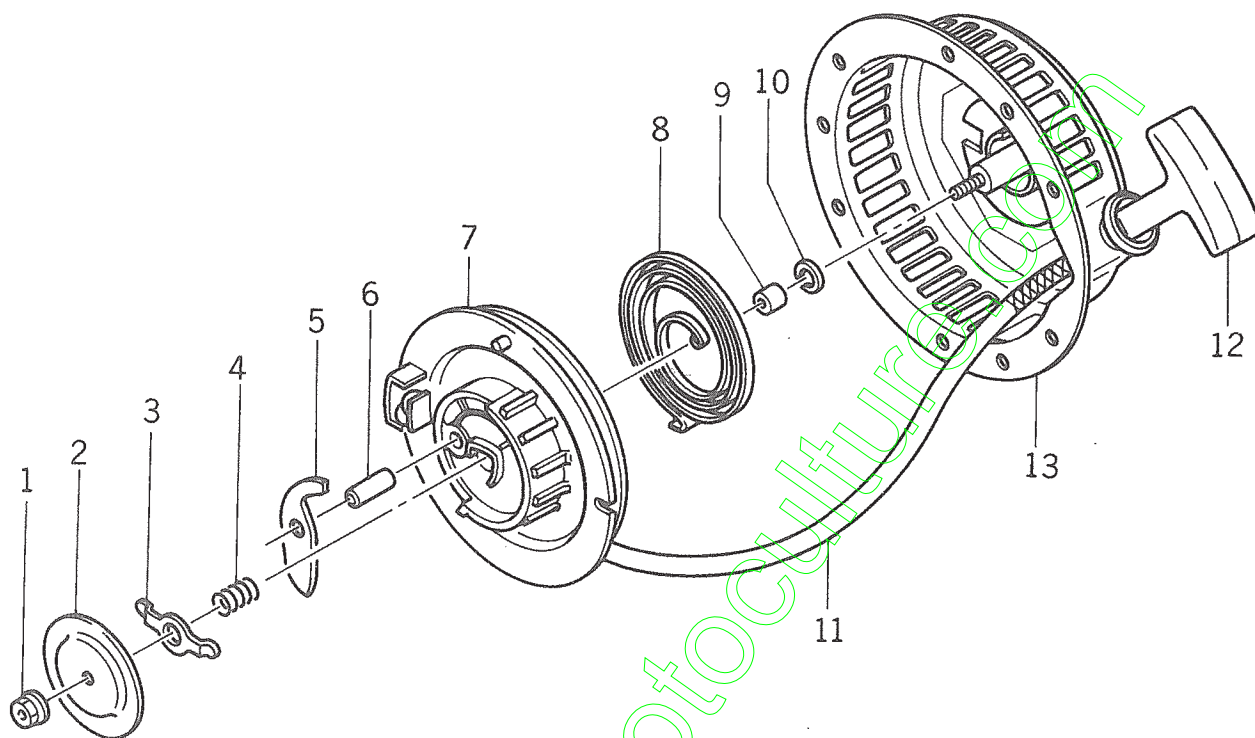

Fig. C-2 CARBURETOR
Carburateur

Ref. No. Réf. No.	Part No. Pièces No.	Description Désignation	Q'ty Quant.	Remarks Remarques
	5150-012-491-XX	CARBURETOR ASSY Ensemble carburateur	1	15001-2491
C-2- 1	5144-996-142-AX	• SHAFT, CHOKE Axe volet d'air	1	314499-6142A
C-2- 2	5144-826-102-AX	• VALVE, CHOKE Volet d'air	1	314482-6102A
C-2- 3	5154-706-137-AX	• SCREW Vis	2	315470-6137A
C-2- 4	5127-596-112-00	• JET, PILOT/#35 Vis de mélange	1	312759-6112-00
C-2- 5	5144-996-114-AX	• SCREW, PILOT Vis de ralenti	1	314499-6114A
C-2- 6	5127-506-116-00	• SPRING Ressort	2	312750-6116-00
C-2- 7	5214-B04-14X-XX	• SCREW/M4x14 Vis	1	214B0414
C-2- 8	5144-826-139-AX	• SHAFT, THROTTLE Axe papillon	1	314482-6139A
C-2- 9	5127-506-101-AX	• VALVE, THROTTLE/#130 Papillon	1	312750-6101A
C-2-10	5143-106-137-AX	• SCREW Vis	1	314310-6137A
C-2-11	5136-616-132-00	• JET, MAIN/#70 Gicleur principal	1	313661-6132-00
C-2-12	5145-956-122-AX	• NEEDLE VALVE Ensemble pointeau	1	314595-6122A
C-2-13	5145-956-134-AX	• CLIP Clip	1	314595-6134A
C-2-14	5145-966-129-AX	• NOZZLE, MAIN/#2A Gicleur	1	314596-6129A
C-2-15	5145-956-126-AX	• FLOAT Flotteur	1	314595-6126A
C-2-16	5144-996-127-AX	• PIN, FLOAT Axe	1	314499-6127A
C-2-17	5145-986-128-AX	• GASKET Joint	1	314598-6128A
C-2-18	5160-202-076-XX	• FLOAT CHAMBER ASSY Cuve	1	16020-2076
C-2-19	5154-706-133-AX	• SCREW, DRAIN Bouchon de vidange	1	315470-6133A
C-2-20	5131-226-116-00	• SPRING Ressort	1	313122-6116-00
C-2-21	5145-966-143-AX	• BOLT Vis	1	314596-6143A
C-2-22	5144-996-159-AX	• GASKET Joint	1	314499-6159A

Fig. R-2 RECOIL STARTER
Lanceur



Ref. No. Réf. No.	Part No. Pièces No.	Description Désignation	Q'ty Quant.	Remarks Remarques
	5490-882-286-ZM	RECOIL STARTER ASSY Ensemble lanceur	1	49088-2286-ZM
R-2- 1	5156-013-443-AX	•NUT Ecrou	1	315601-3443A
R-2- 2	5156-013-449-AX	•COVER, RETAINER Disque d'encliquetage	1	315601-3449A
R-2- 3	5130-702-060-XX	•GUIDE, PAWL Guide, cliquet	1	13070-2060
R-2- 4	5921-442-017-XX	•SPRING Ressort	1	92144-2017
R-2- 5	5131-652-066-XX	•PAWL, RECOIL Cliquet	1	13165-2066
R-2- 6	5146-013-473-AX	•PIN, PAWL Axe, cliquet	1	314601-3473A
R-2- 7	5591-012-072-XX	•REEL, RECOIL Bobine de renvidage	1	59101-2072
R-2- 8	5156-013-452-AX	•SPRING, RECOIL Ressort spirale	1	315601-3452A
R-2- 9	5156-013-458-AX	•WASHER Rondelle	1	315601-3458A
R-2-10	5156-013-442-AX	•WASHER, THRUST Rondelle	1	315601-3442A
R-2-11	5591-062-082-XX	•ROPE/M5x1500 Cordon	1	59106-2082
R-2-12	5136-503-454-BX	•HANDLE, RECOIL STARTER Poignée	1	313650-3454B
R-2-13	5320-992-119-ZM	•CASE, RECOIL Boitier, ensemble	1	32099-2119-ZM

CHASSIS

www.emc-motoculture.com

目 次

ISEKI POWER TILLER A280

		PAGE
Fig. 1	FRAME Longeron	25
Fig. 2	ENGINE BASE AND FENDER Mmbase de moteur et garde-boue	27
Fig. 3	BELT DRIVE SYSTEM Système d'entraînement	29
Fig. 4	GEAR CASE Boîtier de réducteur	31
Fig. 5	TRANSMISSION GEARS Réducteur	33
Fig. 6	SHIFTER Fourchette	35
Fig. 7	HANDLEBAR FRAME Mancheron	37
Fig. 8	CLUTCH LEVER Poigne d'embrayage	39
Fig. 9	ENGINE HOOD AND FUEL TANK (2E40) ... Réservoir et capot	41
Fig.10	ENGINE HOOD AND FUEL TANK (E40) Réservoir et capot	43
Fig.11	BELT COVER Carter de courroies	45
Fig.12	LABELS Étiquettes	46
Fig.13	TOOLS Outils	47
Fig.14	POWER TAKE-OFF Poulie de prise de force	48

Fig. 1 FRAME
Longeron

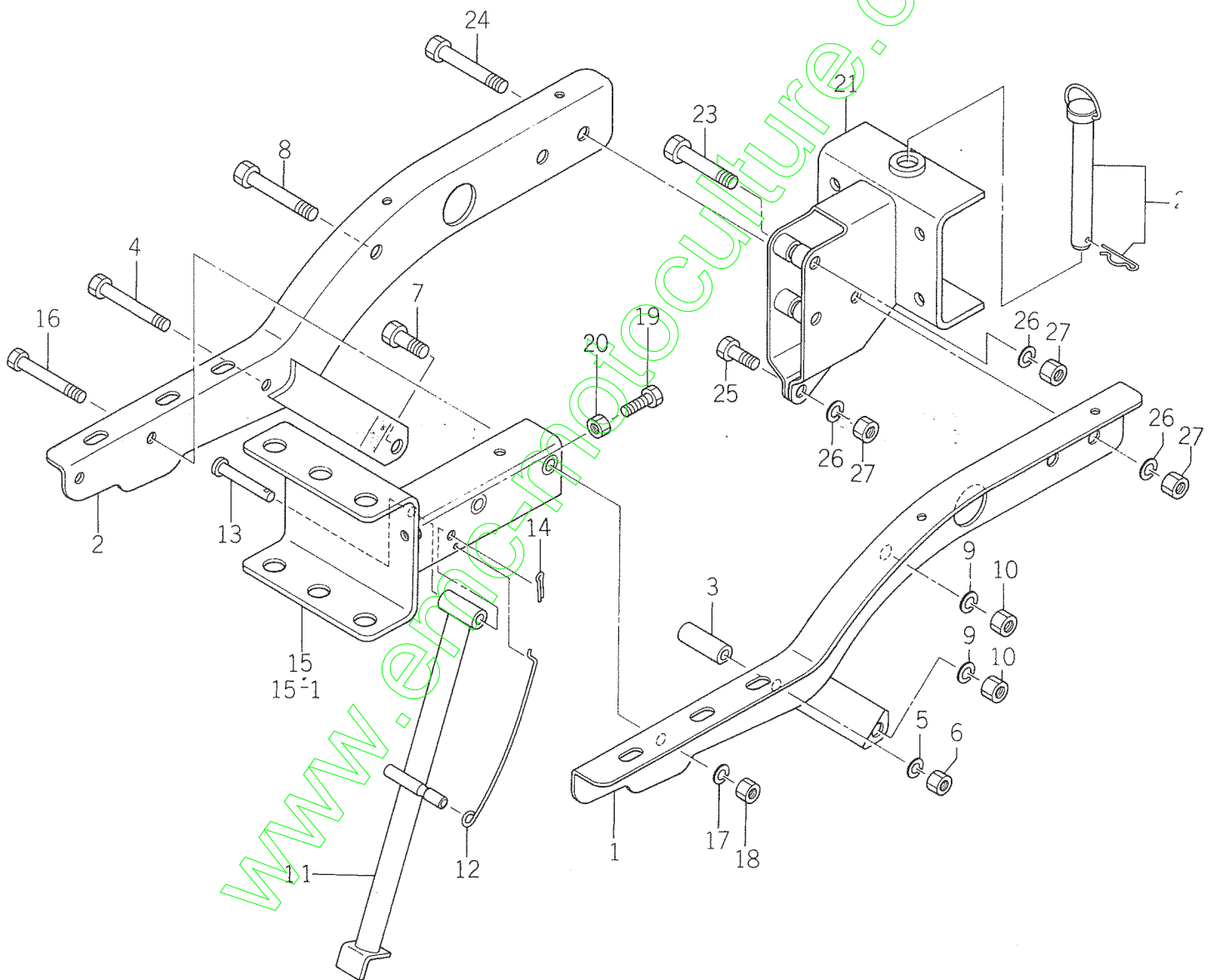

Ref No. Réf N°.	Parts No. Pièces N°.	Description Désignation	Qty Quant				Remarks Remarques
			2E 40	2RE 40	E 40	RE 40	
1- 1	1103-101-200-00	FRAME LH COMP. Longeron G.	1		1		
1- 2	1103-101-210-00	FRAME RH COMP. Longeron D.	1		1		
1- 3	1350-101-001-00	PIPE/39 Tubulure	1		1		
1- 4	V201-260-806-00	BOLT/M8x60 Vis	1		1		
1- 5	V401-160-008-00	WASHER, SP/M10 Rondelle frein	1		1		
1- 6	V300-260-008-00	NUT/M8 Erou	1		1		
1- 7	V201-261-002-50	BOLT/M10x25 Vis	1		1		
1- 8	V201-261-006-00	BOLT/M10x60 Vis	2		2		
1- 9	V401-160-010-00	WASHER, SP/M10 Rondelle frein	3		3		
1-10	V300-260-010-00	NUT/M10 Erou	3		3		
1-11	1103-106-200-00	STAND COMP Bequille	1		1		
1-12	1329-106-001-00	SPRING, STAND Ressort	1		1		
1-13	3560-302-002-00	PIN, STAND Axe de béquille	1		1		
1-14	V500-152-501-50	PIN, SPLIT Goupille fendue	1		1		
1-15	1103-111-200-00	HITCH, F, COMP. Attelage ant	1				
1-15-1	1103-112-200-00	HITCH, F, COMP. Attelage ant			1		
1-16	V201-260-806-00	BOLT/M8x60 Vis	2		2		
1-17	V401-160-008-00	WASHER, SP/M8 Rondelle frein	2		2		
1-18	V300-260-008-00	NUT/M8 Erou	2		2		
1-19	V201-260-802-50	BOLT/M8x25 Vis	2		2		
1-20	V302-260-008-00	NUT/M8 Erou	2		2		
1-21	1103-130-200-00	HITCH, R, COMP Attelage ar	1		1		
1-22	1390-931-200-00	PIN, KING, ASSY Broche	1		1		
1-23	V201-261-005-00	BOLT/M8x50 Vis	1		1		
1-24	V201-261-006-00	BOLT/M8x60 Vis	1		1		
1-25	V201-261-002-50	BOLT/M10x25 Vis	1		1		
1-26	V401-160-010-00	WASHER, SP/M10 Rondelle frein	3		3		
1-27	V300-260-010-00	NUT/M10 Erou	3		3		

Fig. 2 ENGINE BASE AND FENDER
 Mbase de moteur et garde-boue

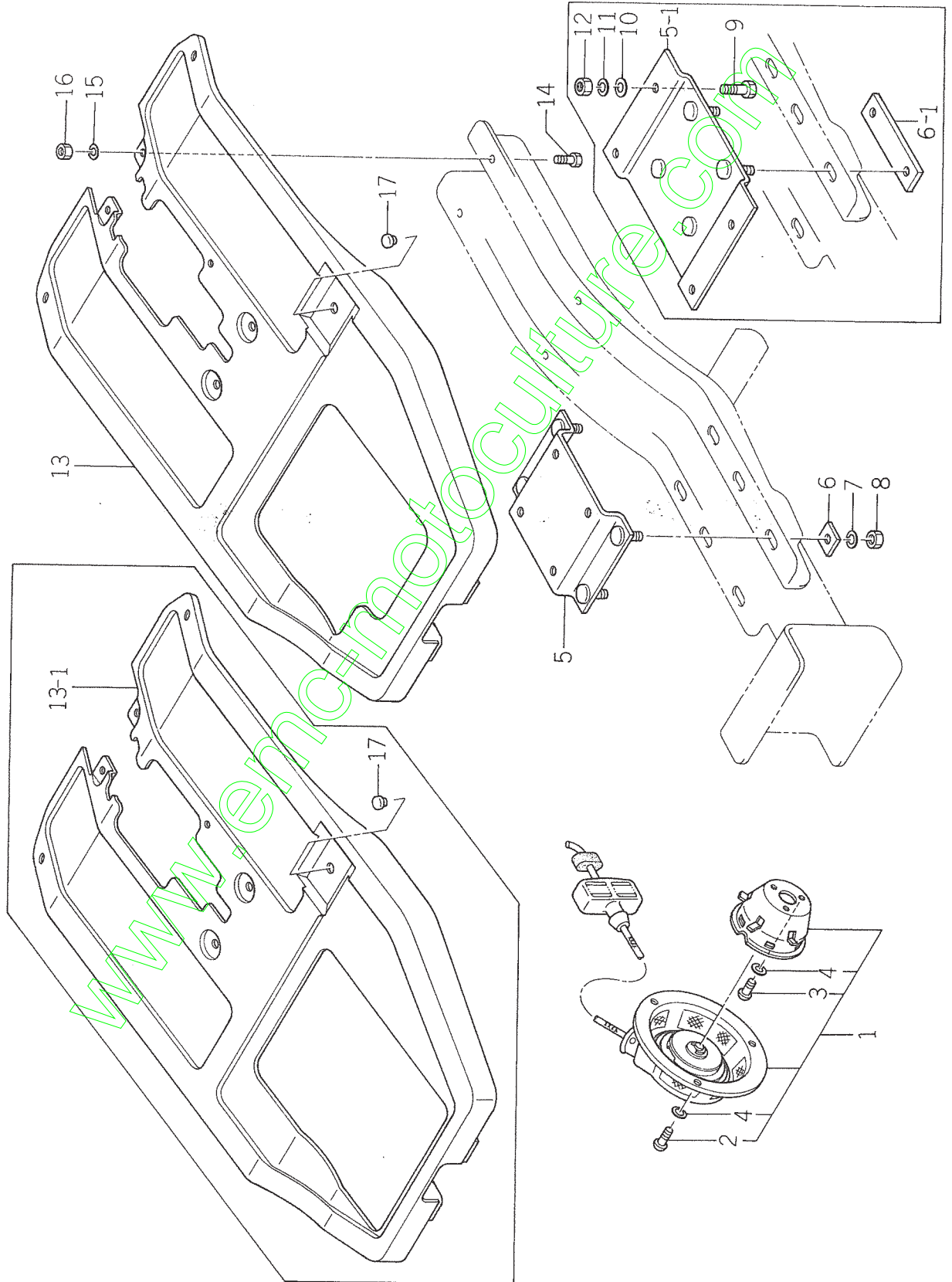

Ref No. Réf N°	Parts No. Pièces N°	Description Désignation	Qty Quant				Remarks Remarques
			2E 40	2RE 40	E 40	RE 40	
2- 1	1353-121-200-00	STARTER. RECOIL, ASSY Lanceur complet	1				
2- 2	V111-166-000-80	SCREW/M6×8 Vis	3				
2- 3	V111-166-001-00	SCREW/M6×10 Vis	3				
2- 4	V401-160-006-00	WASHER, Rondelle	6				
2- 5	1103-121-200-00	BASE (2), ENGINE, COMP. Embase de moteur (2)	1				
2- 5-1	1103-122-210-00	BASE (4), ENGINE, COMP. Embase de moteur (4)			1		
2- 6	1396-121-001-00	PLATE Plaque	4				
2- 6-1	1102-122-001-00	PLATE (1, 19×92) Plaque			2		
2- 7	V401-160-008-00	WASHER, SP/M8 Rondelle frein	4		4		
2- 8	V300-260-008-00	NUT/M8 Ecrou	4		4		
2- 9	V201-260-804-00	BOLT/M8×40 Vis			4		
2-10	V411-260-008-00	WASHER/M8 Rondelle	4		4		
2-11	V401-160-008-00	WASHER, SP/M8 Rondelle frein	4		4		
2-12	V300-260-008-00	NUT/M8 Ecrou	4		4		
2-13	1103-616-200-00	FENDER (2), COMP. Garde-boue	1				
2-13-1	1103-617-200-00	FENDER (4), COMP Garde-boue			1		
2-14	V200-260-601-20	BOLT/M6×12 Vis	4		4		
2-15	V401-160-006-00	WASHER, SP/M6 Rondelle frein	4		4		
2-16	V300-260-006-00	NUT/M6 Ecrou	4		4		
2-17	1366-726-006-00	PLUG (8) Bouchon	1		1		

Fig. 3 BELT DRIVE SYSTEM
Système d'entraînement

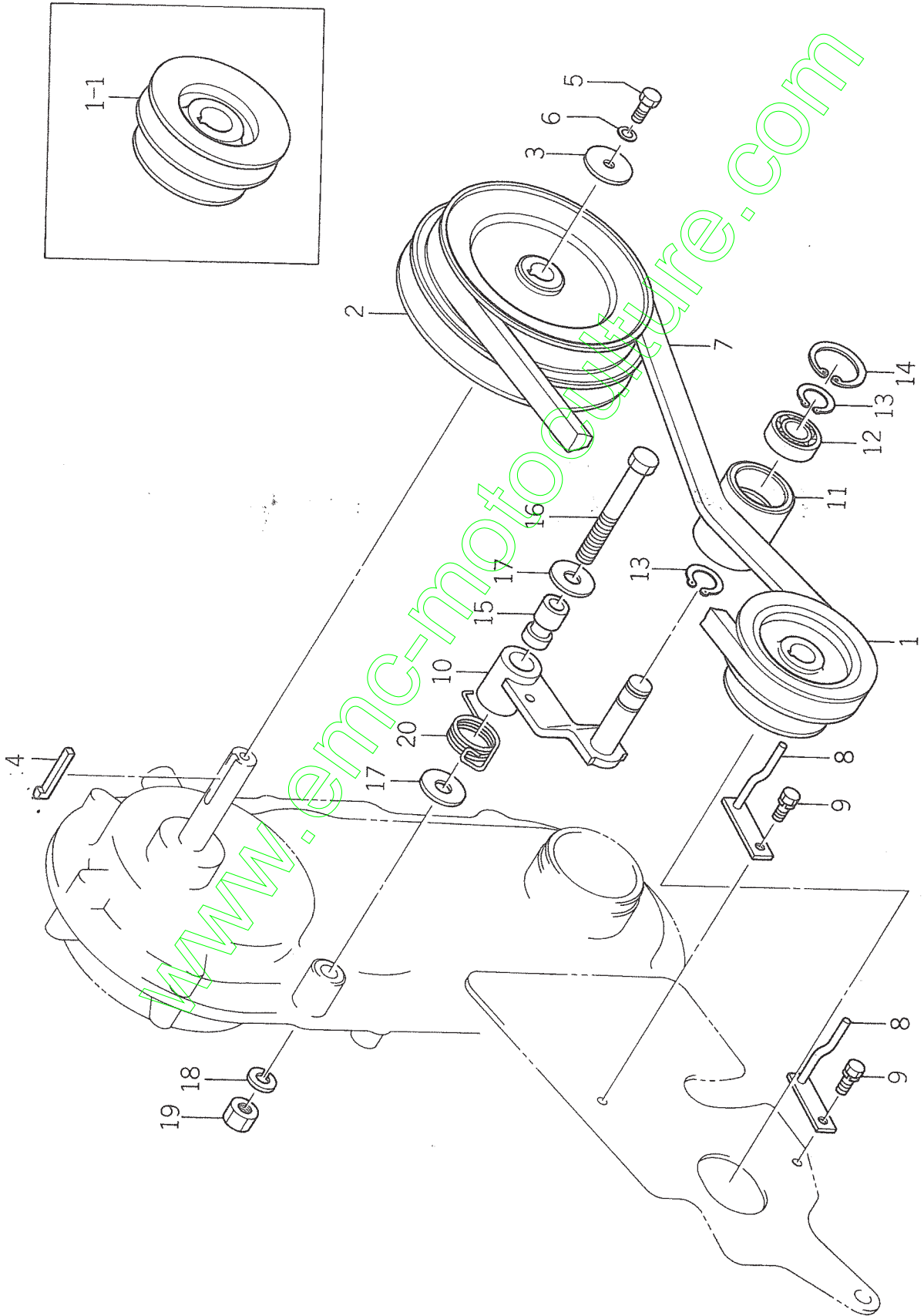

Ref No. Réf N°.	Parts No. Pièces N°.	Description Désignation	Qty Quant				Remarks Remarques
			2E 40	2RE 40	E 40	RE 40	
3- 1	1103-201-001-00	PULLEY (VB057B078) Poulie	1				
3- 1-1	1103-202-001-00	PULLEY (VB060B080) Poulie			1		
3- 2	1103-201-200-00	PULLEY (VB122B140) COMP. Poulie	1		1		
3- 3	1305-701-006-00	WASHER Rondelle	1		1		
3- 4	1329-201-003-00	KEY, MAIN SHAFT Clavette	1		1		
3- 5	V200-260-601-60	BOLT/M6x16 Vis	1		1		
3- 6	V401-160-006-00	WASHER, SP/M6 Rondelle frein	1		1		
3- 7	V817-200-033-00	BELT, V- Courroie trapézoïdale	1		1		
3- 8	1103-201-210-00	STOPPER, BELT, COMP. Arrêt de courroie	2		2		
3- 9	V210-260-601-20	BOLT (S)/M6x12 Vis	2		2		
3-10	1103-203-200-00	ARM, TENSION, COMP. Tirant	1		1		
3-11	1398-202-001-00	PULLEY/41x50 Poulie	1		1		
3-12	V600-150-620-20	BEARING, RB Roulement	1		1		
3-13	V704-140-015 00	RING, SNAP, (SHAFT)/15 Collet d'axe	2		2		
3-14	V705-140-035-00	RING, SNAP, (HOLE)/35 Collet d'axe	1		1		
3-15	1350-202-002-00	BUSH Coussinet	1		1		
3-16	V201-261-008-50	BOLT/M10x85 Vis	1		1		
3-17	V411-260-010-00	WASHER/M10 Rondelle	2		2		
3-18	V401-160-010-00	WASHER, SP/M10 Rondelle frein	1		1		
3-19	V300-260-010-00	NUT/M10 Ecrou	1		1		
3-20	1350-202-003-00	SPRING, RETURN Ressort de rappel	1		1		

Fig. 4 GEAR CASE
Boîtier de réducteur

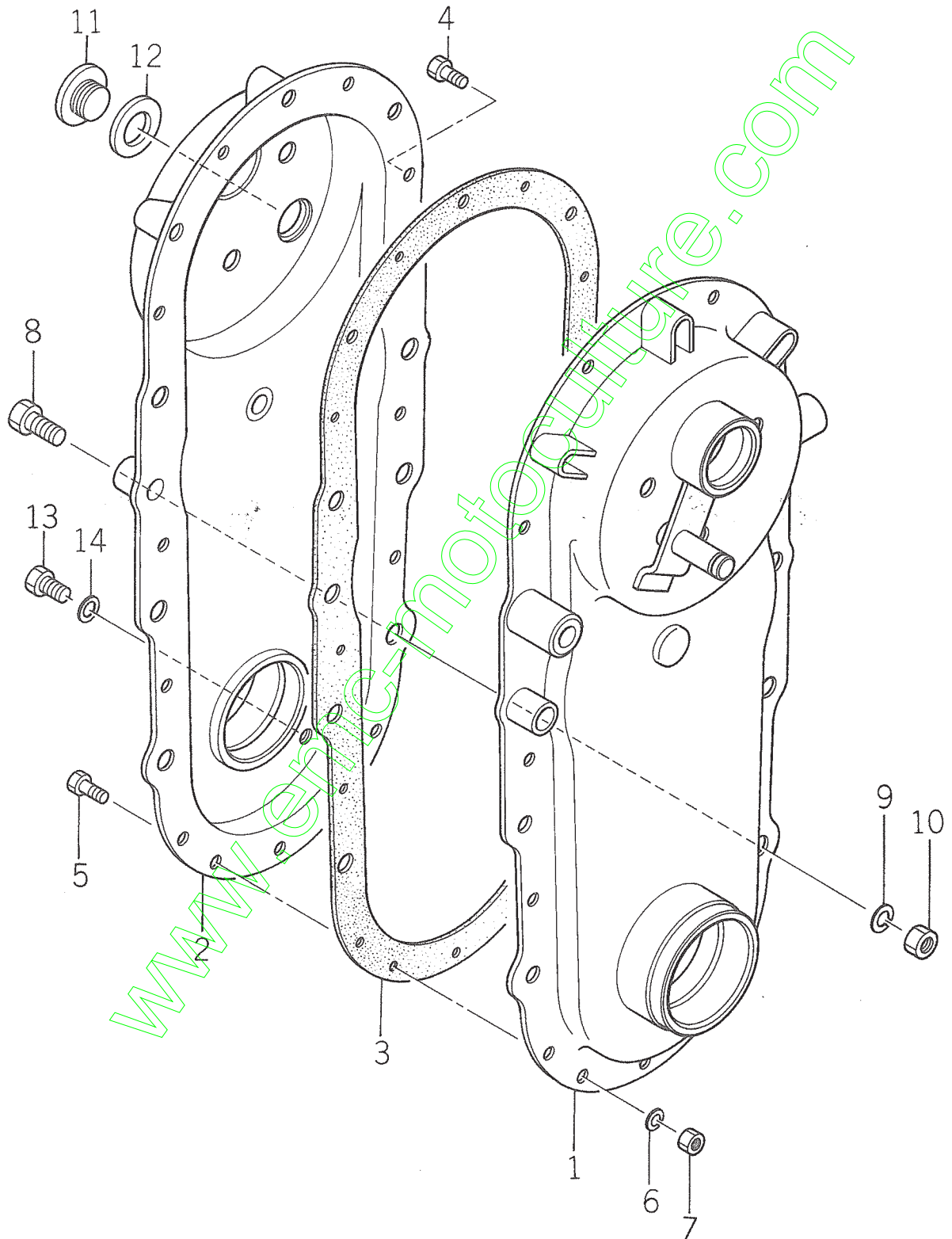

Ref No. Réf N°.	Parts No. Pièces N°.	Description Désignation	Qty Quant				Remarks Remarques
			2E 40	2RE 40	E 40	RE 40	
4- 1	1103-216-200-00	CASE, GEAR, LH COMP. Coquille G.	1		1		
4- 2	1103-216-210-00	CASE, GEAR, RH COMP. Coquille D.	1		1		
4- 3	1103-216-001-00	PACKING, GEAR CASE Joint	1		1		
4- 4	V200-260-602-00	BOLT/M6×20 Vis	1		1		
4- 5	V200-260-601-20	BOLT/M6×12 Vis	12		12		
4- 6	V401-260-006-00	WASHER, SP/M6 Rondelle frein	13		13		
4- 7	V300-260-006-00	NUT/M6 Erou	13		13		
4- 8	V201-261-002-50	BOLT/M10×25 Vis	1		1		
4- 9	V401-260-010-00	WASHER, SP/M10 Vis	1		1		
4-10	V300-260-010-00	NUT/M10 Erou	1		1		
4-11	1343-216-002-00	PLUG, OIL FILLER Bouchon			1		
4-12	1343-216-003-00	PACKING, PLUG Joint			1		
4-13	V200-260-801-20	BOLT/M8×12 Vis	1		1		
4-14	1407-111-001-00	WASHER/8×12×2 Rondelle	1		1		

Fig. 5 TRANSMISSION GEARS
Réducteur

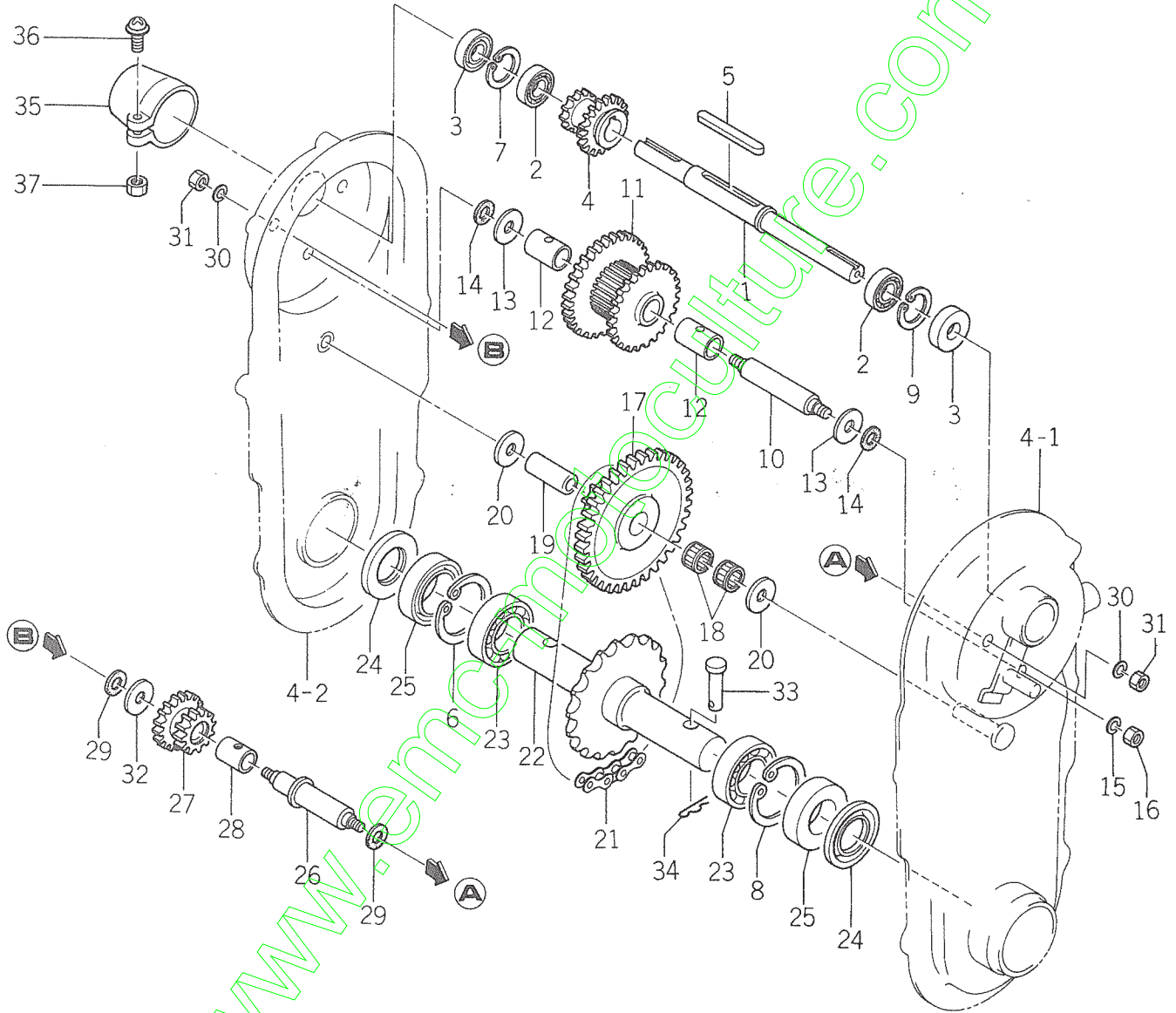

Ref No. Réf N°.	Parts No. Pièces N°.	Description Désignation	Q'ty Quant				Remarks Remarques
			2E 40	2RE 40	E 40	RE 40	
5- 1	1103-217-001-00	SHAFT, MAIN Arbre primaire	1		1		
5- 2	V600-110-600-20	BEARING, RB Roulement	2		2		
5- 3	V740-115-320-70	SEAL, OIL Bague d'étanchéité	2		2		
5- 4	1353-217-001-00	GEAR, SHIFT/14-21T Baladeur	1		1		
5- 5	1350-217-003-00	KEY/5X5X60 Clavette	1		1		
5- 6	V705-140-055-00	RING, SNAP, (HOLE)/55 Collet d'axe	1		1		
5- 7	V705-140-032-00	RING, SNAP, (HOLE)/32 Collet d'axe	1		1		
5- 8	V705-140-055-00	RING, SNAP, (HOLE)/55 Collet d'axe	1		1		
5- 9	V705-140-032-00	RING, SNAP, (HOLE)/32 Collet d'axe	1		1		
5-10	1350-220-001-00	SHAFT, COUNTER Arbre intermédiaire	1		1		
5-11	1350-220-100-00	GEAR, COUNTER, COMP./31-41T Pignon fou	1		1		
5-12	1350-220-002-00	BUSH (A), ROLL, Coussinet	2		2		
5-13	1350-220-004-00	COLLAR/10X28X3 Bague	2		2		
5-14	1343-220-003-00	PACKING Joint	2		2		
5-15	V401-260 010-00	WASHER, SP/M10 Rondelle frein	2		2		
5-16	1305-260-010-00	NUT (GRADE 3)/M10 Erou	2		2		
5-17	1350-221-100-00	GEAR, REDUCTION, COMP. Pignon	1		1		
5-18	1350-221-001-00	BEARING, NR Roulement	2		2		
5-19	1350-221-003-00	BUSH/10X16X30 Coussinet	1		1		
5-20	1350-220-004-00	COLLAR/10X28X3 Bague	2		2		
5-21	1350-221-004-00	CHAIN, ROLLER Chaine	1		1		
5-22	1350-225-100-00	SHAFT, WHEEL, COMP. Fusée	1		1		
5-23	V600-110-600-60	BEARING, RB Roulement	2		2		
5-24	V742-130-550-50	SEAL, OIL Bague d'étanchéité	2		2		
5-25	V744-130-551-20	SEAL, OIL Bague d'étancheite	2		2		
5-26	1350-226-001-00	SHAFT, BACK Axe de M.AR.	1		1		
5-27	1350-226-002-00	GEAR, BACK/16-22T Pignon de M.AR.	1		1		
5-28	1350-226-003-00	BUSH, ROLL/14X17X24 Coussinet	1		1		
5-29	1343-220-003-00	PACKING Joint	2		2		
5-30	1401-260-010-00	WASHER, SP Rondelle frein	2		2		
5-31	1305-160-010-00	NUT (GRADE 3) Erou	2		2		
5-32	1350-220-004-00	COLLAR/10X28X3 Bague	1		1		
5-33	1310-241-003-00	PIN (A), WHEEL PIPE Goupille	4		4		
5-34	1305-241-001-00	PIN, HAIR Attache beta	4		4		
5-35	1103-216-002-00	CAP, SHAFT/42X50 Embout	1		1		
5-36	V120-165-002-50	SCREW/M5X25 Vis	1		1		
5-37	V300-260-005-00	NUT/M5 Ecrpu	1		1		

Fig. 6 SHIFTER
Fourchette

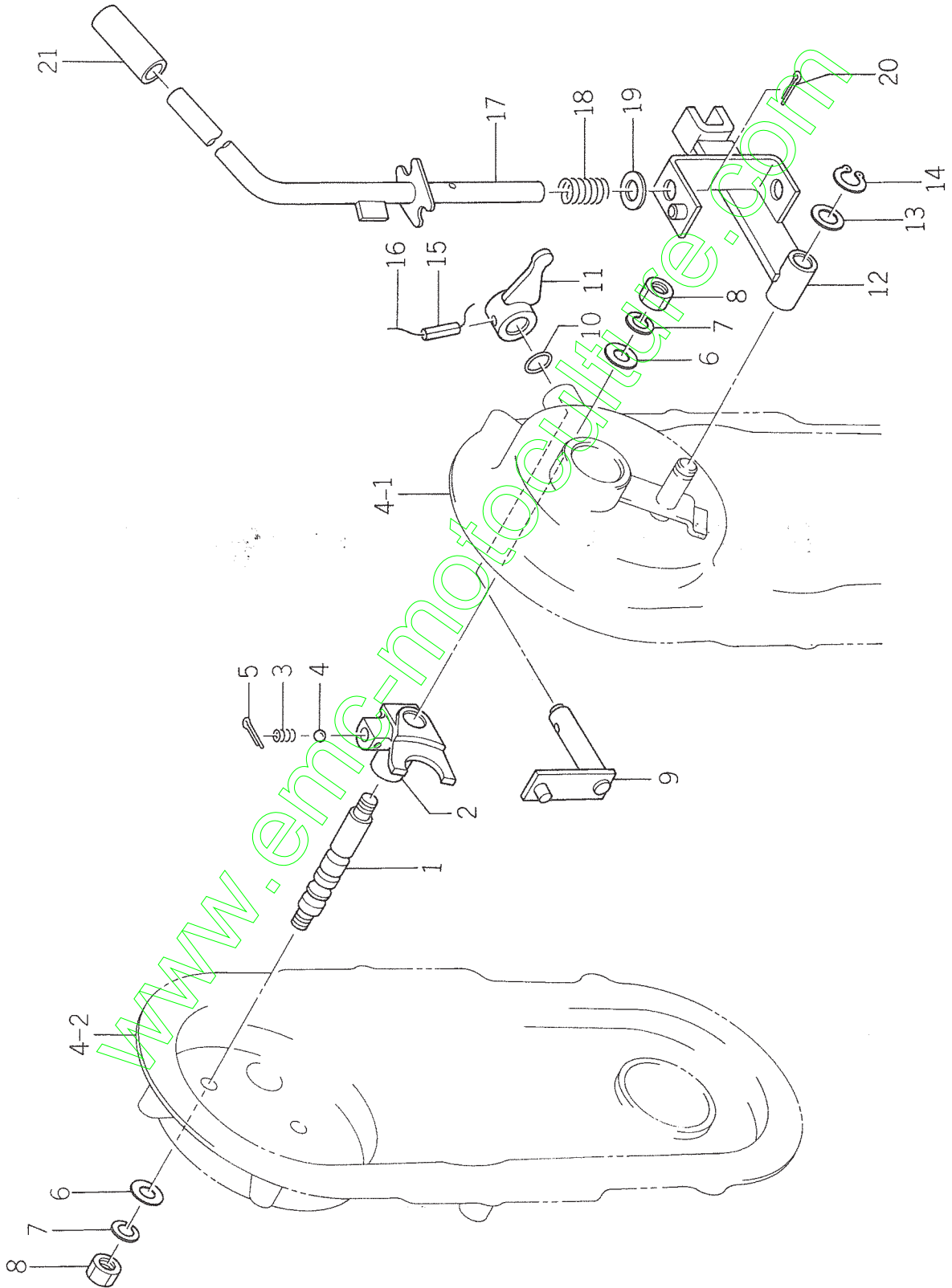

Ref No. Réf N°	Parts No. Pièces N°	Description Désignation	Qty Quant				Remarks Remarques
			2E 40	2RE 40	E 40	RE 40	
6- 1	1350-229-001-00	STAY, SHIFTER/Ø13 Axe de fourchette	1		1		
6- 2	1350-229-002-00	SHIFTER Fourchette	1		1		
6- 3	1301-229-004-00	SPRING, SHIFTER/Ø11 Ressort de Verrouillage	1		1		
6- 4	V680-200-001-00	BALL, STEEL Bille de Verrouillage	1		1		
6- 5	V500-152-002-50	PIN, SPLIT Goupille fendue	1		1		
6- 6	1343-229-004-00	PACKING, SHIFTER STAY/t=0.2 Joint	1		1		
6- 7	V401-260-010-00	WASHER, SP/MI 0 Rondelle frein	2		2		
6- 8	1305-160-010-00	NUT (GRADE 3) Eccrou	2		2		
6- 9	1350-229-100-00	ARM, SHIFT, COMP. Sélecteur	1		1		
6-10	V720-102-401-20	O-RING/P12 Joint torique			1		
6-11	1103-403-210-00	ARM, CHANGE, COMP. Lever de sélecteur			1		
6-12	1103-403-220-00	ARM, SELECT, COMP. Bras de Sélecteur			1		
6-13	V411-260-012-00	WASHER/MI 2 Rondelle	1		1		
6-14	V704-140-012-00	RING, SNAP, (SHAFT)/12 Collet d'axe	1		1		
6-15	V580-140-602-50	PIN, ROLL(W), 6x25 Goupille élastique	1		1		
6-16	V590-131-010-00	WIRE/1.0x100 Fil	1		1		
6-17	1103-403-230-00	LEVER, SHIFT, COMP. Lever de changement de vitesse	1		1		
6-18	1381-403-002-00	SPRING, PRESSURE/24 Ressort	1		1		
6-19	V411-260-012-00	WASHER/MI 2 Rondelle	1		1		
6-20	V500-162-502-00	PIN, SPLIT/25x20 Goupille fendue	1		1		
6-21	2101-230-001-00	GRIP Pommeau	1		1		

Fig. 7 HANDLEBAR FRAME
Mancheron

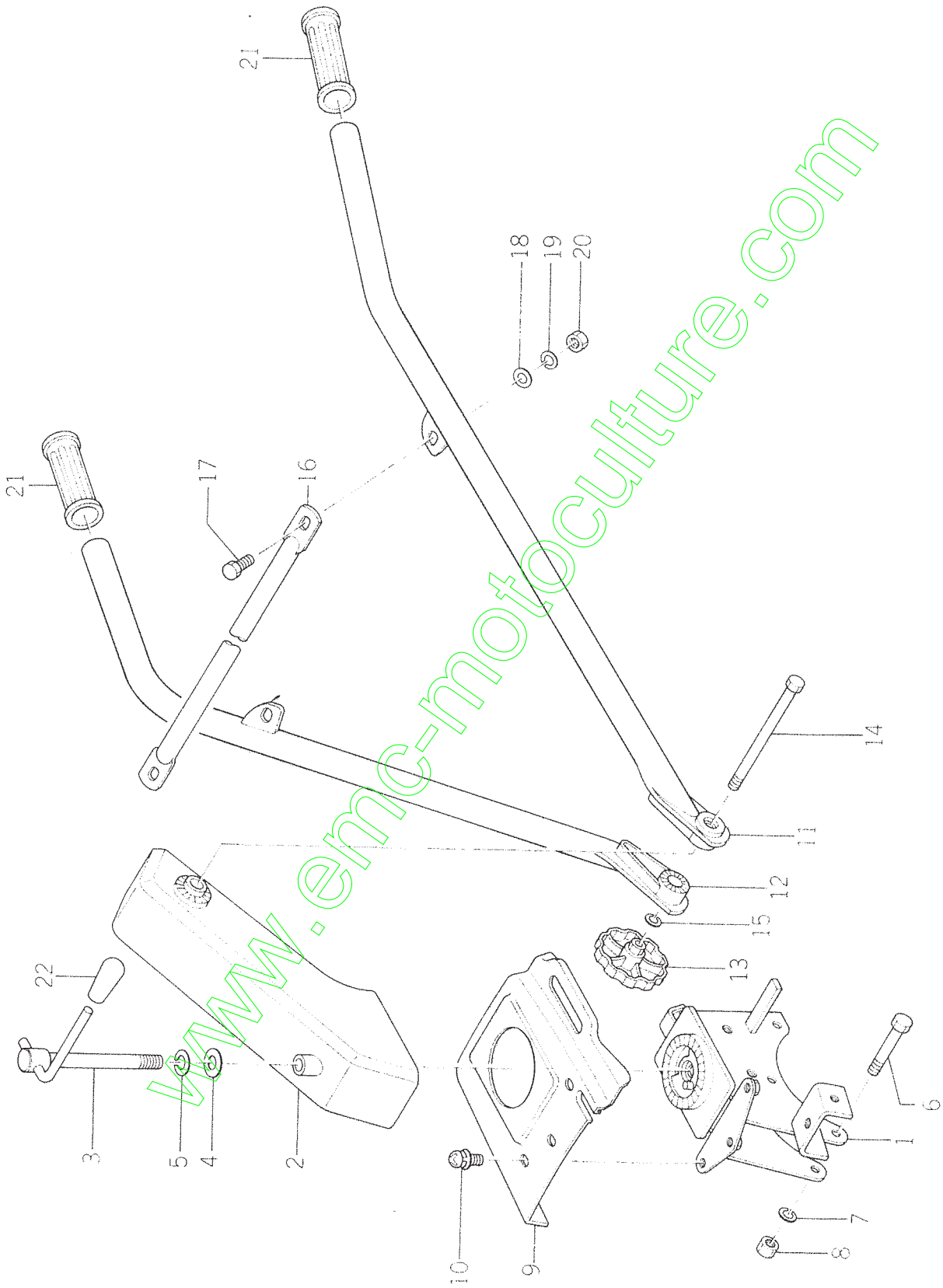

Ref No. Réf N°.	Parts No. Pièces N°.	Description Désignation	Qty Quant				Remarks Remarques
			2E 40	2RE 40	E 40	RE 40	
7-1	1103-301-200-00	BRACKET, HANDLEBAR, COMP. Support	1		1		
7-2	1103-301-210-00	FRAME, HANDLEBAR, COMP. Age	1		1		
7-3	1103-301-220-00	SCREW, LOCK, COMP. Manivelle	1		1		
7-4	V411-260-014-00	WASHER, M14 Rondelle	1		1		
7-5	V401-160-014-00	WASHER, SP/M14 Rondelle frein	1		1		
7-6	V201-260-806-00	BOLT/M8x60 Vis	3		3		
7-7	V401-160-008-00	WASHER, SP/M8 Rondelle frein	3		3		
7-8	V300-260-008-00	NUT/M8 Ecrou	3		3		
7-9	1103-301-001-00	COVER, HANDLEBAR Couvercle	1		1		
7-10	V120-366-001-20	SCREW (SP)/M6x12 Vis	3		3		
7-11	1103-311-200-00	HANDLEBAR LH Mancheron G.			1		
7-12	1103-311-210-00	HANDLEBAR RH Mancheron D.			1		
7-13	1364-311-200-00	KNOB, SET Fermeteur	1		1		
7-14	V200-461-014-00	BOLT/M10x140 Vis	1		1		
7-15	V401-160-010-00	WASHER, SP/M10 Rondelle frein	1		1		
7-16	1103-311-001-00	SUPPORT Support	1		1		
7-17	V201-260-801-60	BOLT/M8x16 Vis	2		2		
7-18	V411-260-008-00	WASHER/M8 Rondelle	2		2		
7-19	V401-160-008-00	WASHER, SP/M8 Rondelle frein	2		2		
7-20	V300-260-008-00	NUT/M8 Ecrou	2		2		
7-21	2100-401-001-00	GLIP, HANDLEBAR Poignée	2		2		
7-22	2101-230-010-00	GRIP Poignée	1		1		

Fig. 8 CLUTCH LEVER
Poigne d'embrayage

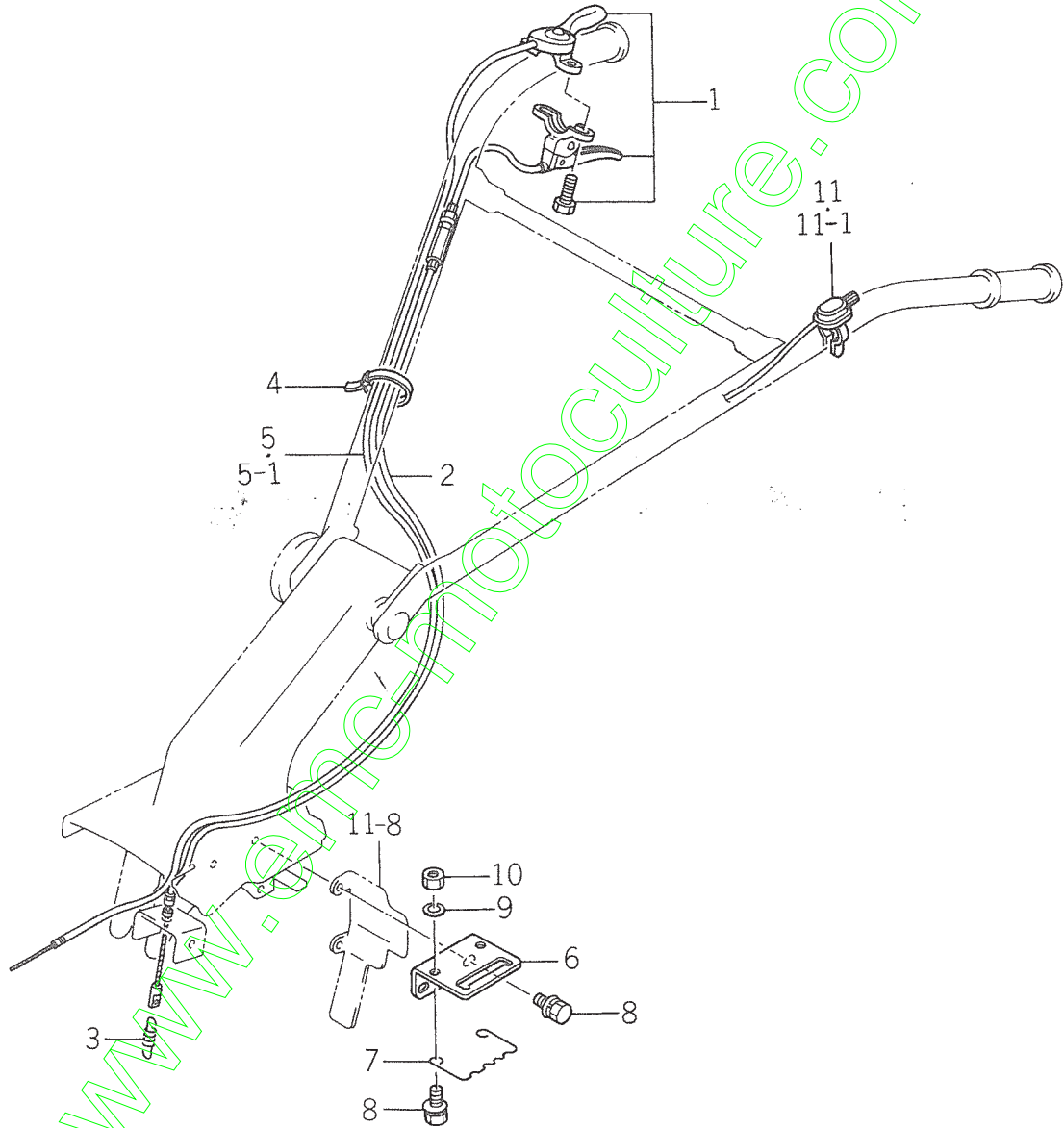

Ref No. Réf N°.	Parts No. Pièces N°.	Description Désignation	Qty Quant				Remarks Remarques
			2E 40	2RE 40	E 40	RE 40	
8-1	1364-401-200-00	LEVER, MAIN CLUTCH, ASSY Poignée d'embrayage	1		1		
8-2	1103-401-001-00	CABLE, MAIN CLUTCH Câble d'embrayage	1		1		
8-3	1325-401-009-00	SPRING, MAIN CLUTCH Ressort	1		1		
8-4	1376-402-003-00	TIE, CABLE Sangle	1		1		
8-5	1103-402-001-00	CABLE, THROTTLE, ASSY Câble d'accélérateur	1				
8-5-1	1100-402-001-00	CABLE ASSY Câble			1		
8-6	1103-403-001-00	GUIDE, SHIFT LEVER Grille de Vitesses	1		1		
8-7	1103-403-002-00	SPRING, LOCK Ressort	1		1		
8-8	V211-360-801-60	BOLT (SP)/M8x16 Vis	4		4		
8-9	V401-160-008-00	WASHER, SP/M8 Rondelle frein	2		2		
8-10	V300-260-008-00	NUT/M8 Ecrou	2		2		
8-11	1103-621-200-00	SWITCH (2), STOP, ASSY Interrupteur	1				
8-12	1103-622-200-00	SWITCH, STOP, ASSY Interrupteur			1		

www.emc-motoculture.com

Fig. 9 ENGINE HOOD AND FUEL TANK (2E40)
R servoir ei capot

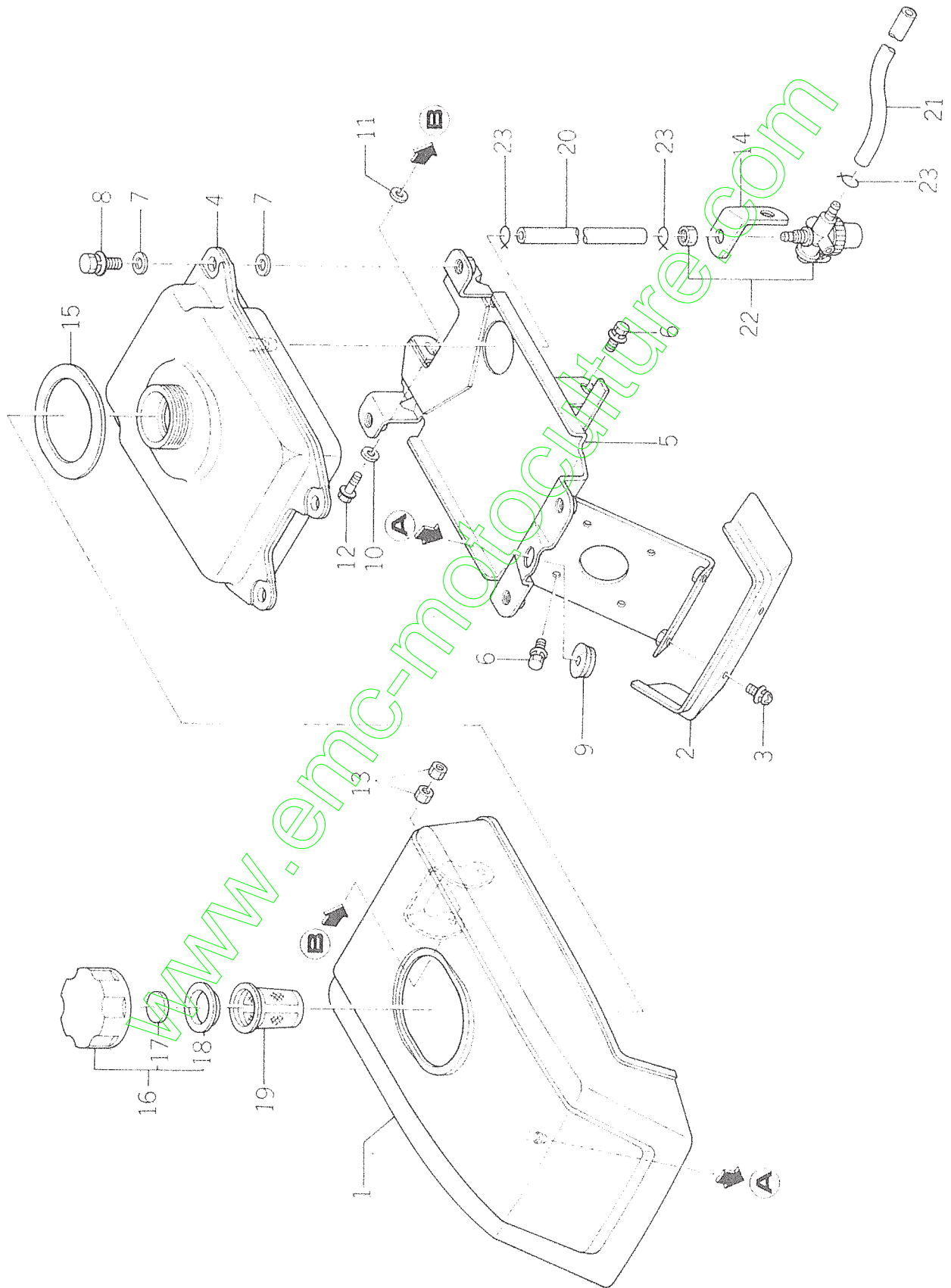

Ref No. Réf N°.	Parts No. Pièces N°.	Description Désignation	Qty Quant				Remarks Remarques
			2E 40	2RE 40	E 40	RE 40	
9-1	1102-601-200-00	HOOD (A) COMP. Capot	1				
9-2	1102-601-001-00	COVER (A), F Carter avant	1				
9-3	V120-366-001-60	SCREW (SP)/M6x16 Vis	2				
9-4	1102-606-001-00	TANK (A), FUEL R	1				
9-5	1102-606-200-00	BRAKET, TANK (A), COMP Support	1				
9-6	V210-360-601-60	BOLT (SP)/M6x16 Vis	6				
9-7	1396-606-002-00	SPACER Entretoise	8				
9-8	V211-360-802-50	BOLT (SP)/M8x25 Vis	4				
9-9	3614-321-001-00	RETAINER, RUBBER Cale en caoutchouc	1				
9-10	2704-301-027-00	WAHER, NYLON Rondelle	2				
9-11	3567-402-004-00	WASHER Rondelle	2				
9-12	V210-160-602-00	BOLT (P)/M6x20 Vis	2				
9-13	V300-260-006-00	NUT/M6 Ecrou	4				
9-14	1102-606-003-00	STAY, STRAINER Support	1				
9-15	1396-601-001-00	INSULATOR/50x130x1 Isolant	1				
9-16	1396-606-210-00	CAP (G55) ASSY Bouchon de réservoir	1				
9-17	2706-501-003-00	◦ BREATHER, TANK CAP Reniflard	1				
9-18	2706-501-004-00	◦ PACKING, TANK CAP Joint	1				
9-19	3555-608-008-00	STRAINER, FUEL Robinet décanteur	1				
9-20	1102-606-004-00	PIPE (A), FUEL/6x9 Conduit	1				
9-21	1102-606-005-00	PIPE (B), FUEL/5x8 Conduit	1				
9-22	1383-606-210-00	STRAINER, FUEL, ASSY Robinet décanteur	1				
9-23	V590-130-909-00	WIRE Fil	3				

Fig.10 ENGINE HOOD AND FUEL TANK (E40)
Réservoir et capot

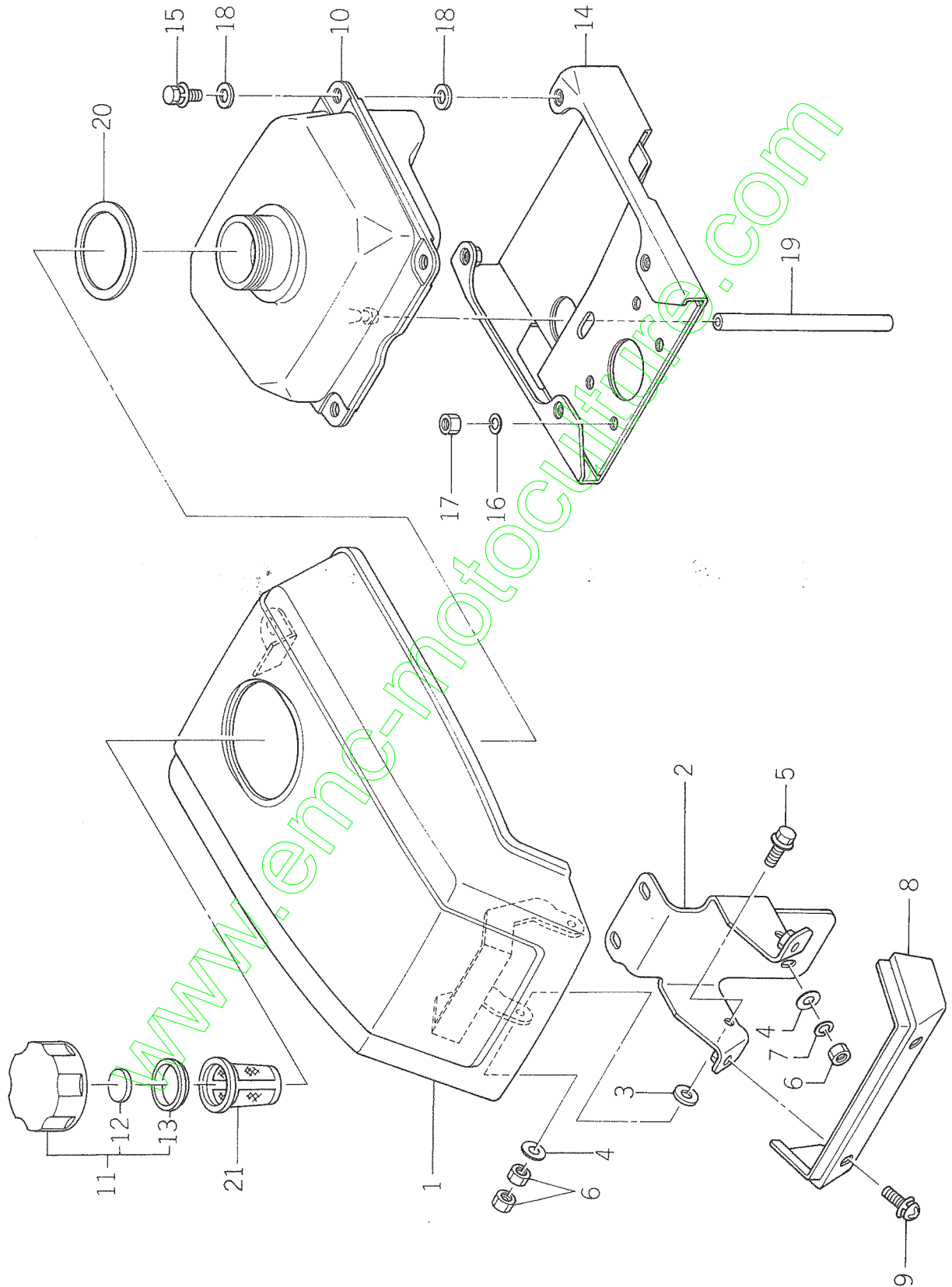

Ref No. Réf N°	Parts No. Pièces N°	Description Désignation	Qty Quant				Remarks Remarques
			2E 40	2RE 40	E 40	RE 40	
10-1	1103-601-200-00	HOOD COMP. Capot			1		
10-2	1103-601-210-00	STAY, HOOD, COMP. Support			1		
10-3	2704-301-027-00	WASHER, NYLON Rondelle			2		
10-4	V411-260-006-00	WASHER/M6 Rondelle			3		
10-5	V210-160-602-00	BOLT (P)/M6x20 Vis			2		
10-6	V300-260-006-00	NUT/M6 Ecou			5		
10-7	V401-160-006-00	WASHER, SP/M6 Rondelle frein			1		
10-8	1103-601-001-00	COVER, F Carter avant					
10-9	V120-366-001-60	SCREW (SP)/M6x16 Vis			2		
10-10	1103-606-001-00	TANK, FUEL Réservoir			1		
10-11	1396-606-210-00	CAP (G55) ASSY Bouchon de réservoir			1		
10-12	2706-501-003-00	• BREATHER, TANK CAP Boutillard			1		
10-13	2706-501-004-00	• PACKING, TANK CAP Joint			1		
10-14	1103-606-200-00	BRACKET, TANK, COMP. Support			1		
10-15	V211-360-802-00	BOLT (SP)/M8x20 Vis			4		
10-16	V401-160-008-00	WASHER, SP/M8 Rondelle			4		
10-17	V300-260-008-00	NUT/M8 Ecou			4		
10-18	1396-606-002-00	SPACER Entretoise			8		
10-19	1103-606-002-00	PIPE (B), FUEL 7x10 Conduit			1		
10-20	1396-601-001-00	INSULATOR 50x130x1 Isolant			1		
10-21	3555-608-008-00	STRAINER, FUEL Robinet décanteur			1		

Fig.11 BELT COVER
Carter de courroies

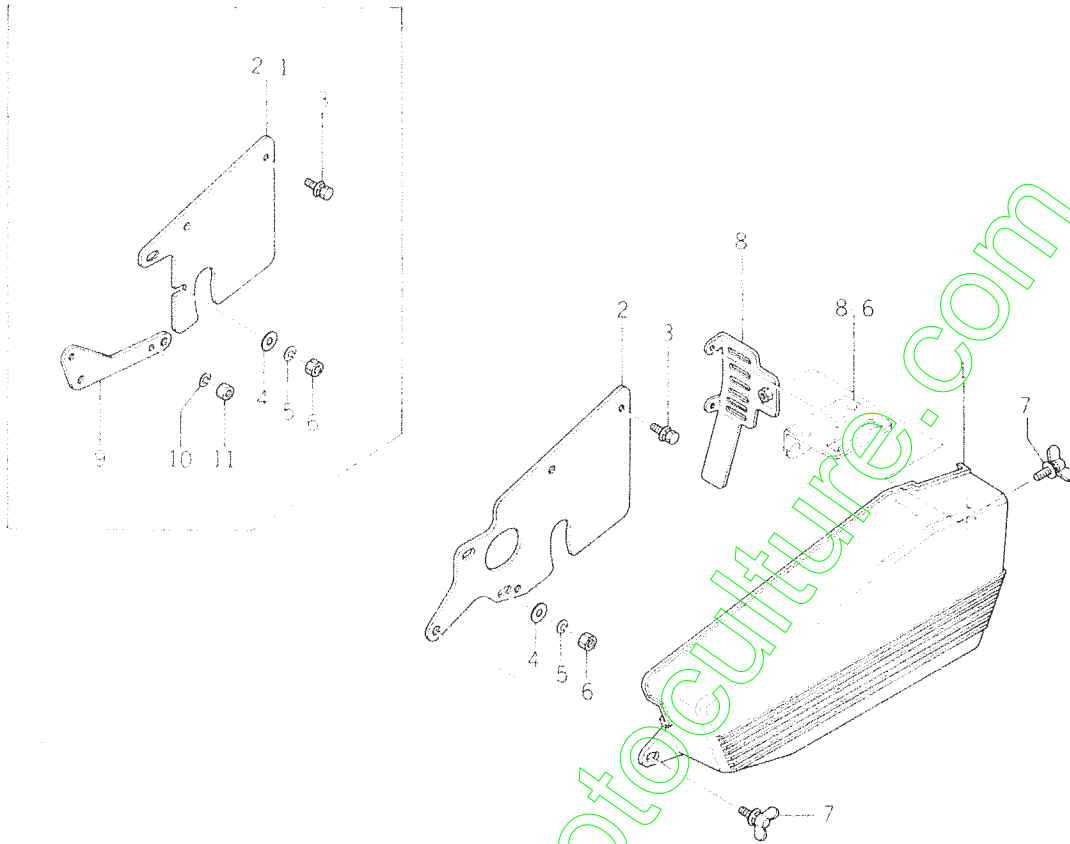

Ref No. Réf N°.	Parts No. Pièces N°.	Description Désignation	Qty Quant				Remarks Remarques
			2E 40	2RE 40	E 40	RE 40	
11- 1	1103-611-001-00	COVER (A), BELT Carter de courroies	1				
11- 2	1103-611-200-00	COVER (B), BELT, COMP. Carter de courroies	1				
11- 2-1	1103-612-200-00	COVER (C), BELT, COMP. Carter de courroies			1		
11- 3	V210-360-601-20	BOLT (SP)/M6×12 Vis	1		1		
11- 4	V411-260-006-00	WASHER/M6 Rondelle	2		2		
11- 5	V401-160-006-00	WASHER, SP/M6 Rondelle frein	2		2		
11- 6	V300-260-006-00	NUT/M6 Erou	2		2		
11- 7	V273-360-802-00	BOLT, WING/M8×20 Vis à oreilles	2		2		
11- 8	1103-611-210-00	STAY, COVER, (A), COMP. Support	1		1		
11- 9	1103-612-210-00	STAY, COVER, (B), COMP. Support			1		
11-10	V401-160-006-00	WASHER, SP/M6 Rondelle frein			2		
11-11	V300-260-006-00	NUT/M6 Erou			2		

Fig.12 LABELS
Etiquettes

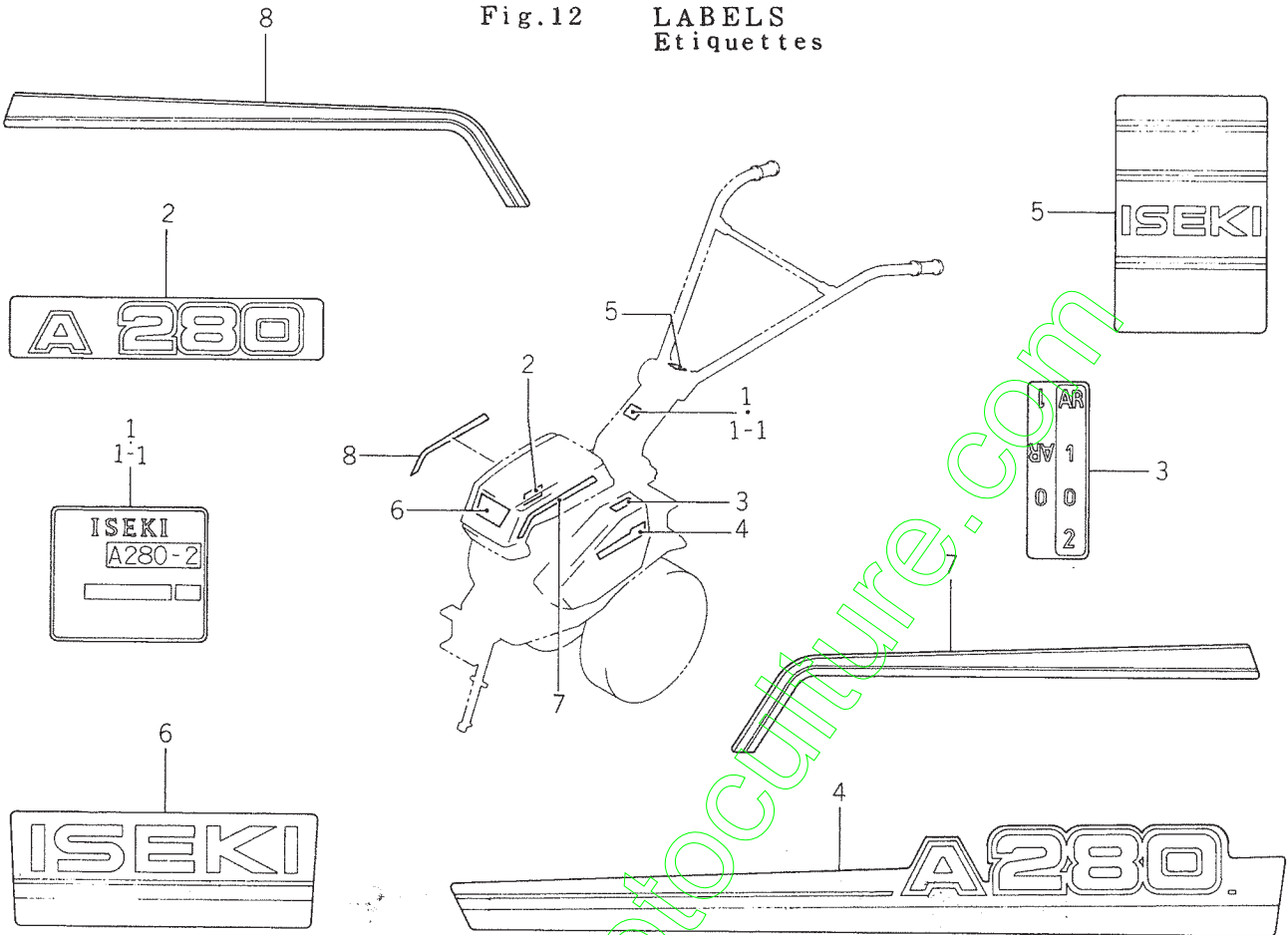

Ref No. Réf N°.	Parts No. Pièces N°.	Description Designation	Qty Quant				Remarks Remarques
			2E 40	2RE 40	E 40	RE 40	
12- 1	1103-901-001-00	LABEL A(2), MODEL Etiquette modele	1				
12- 1-1	1103-902-001-00	LABEL, MODEL Etiquette modele			1		
12- 2	1103-901-002-00	LABEL, ORNAMENTAL Etiquette d'engoliveau	1		1		
12- 3	1103-901-003-00	LABEL, SHIFT GUIDE Etiquette de grille	1		1		
12- 4	1103-901-004-00	LABEL, ORNAMENTAL Etiquette d'engoliveau	1				
12- 5	1103-901-005-00	LABEL, ORNAMENTAL Etiquette d'engoliveau	1		1		
12- 6	1102-901-002-00	LABEL, ORNAMENTAL (ISEKI) Etiquette d'engoliveau (ISEKI)	1		1		
12- 7	1102-901-005-00	LABEL, ORNAMENTAL, LH (STRIPE) Etiquette d'engoliveau G. (languette)	1		1		
12- 8	1102-901-006-00	LABEL, ORNAMENTAL, RH (STRIPE) Etiquette d'engoliveau D. (languette)	1		1		

Fig.13 TOOLS
Outils

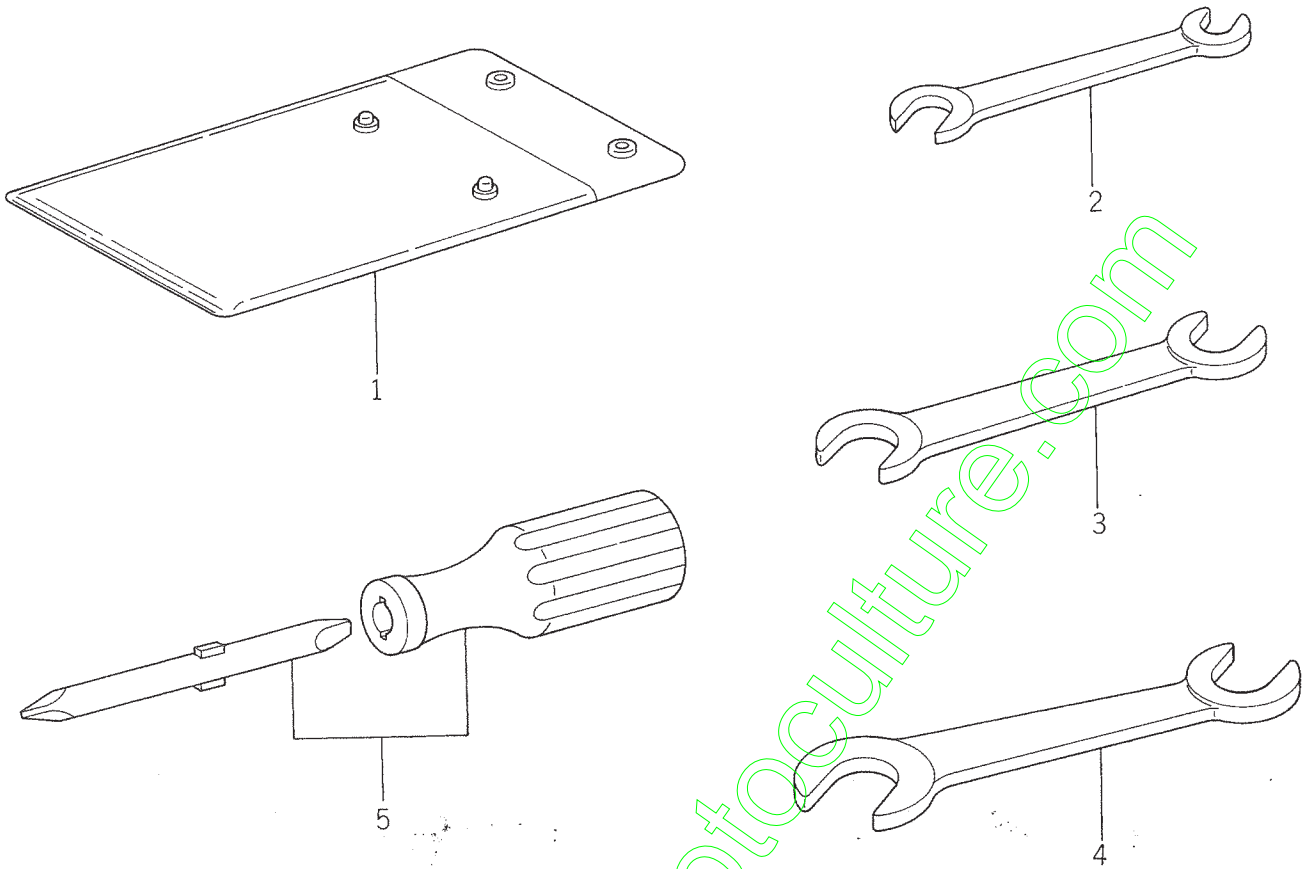

Ref No. Réf N°.	Parts No. Pièces N°.	Description Désignation	Q'ty Quant				Remarks Remarques
			2E 40	2RE 40	E 40	RE 40	
13- 1	1329-906-001-10	BAG, TOOL Pochette à outils	1		1		
13- 2	V920-550-801-00	SPANNER/8-10 Clé plate	1		1		
13- 3	V920-551-201-40	SPANNER/12-14 Clé plate	1		1		
13- 4	V920-551-301-70	SPANNER/13-17 Clé plate	1		1		
13- 5	1381-906-001-00	SCREWDRIVER No 51, D6x150 Tournevis	1		1		

Fig.14 POWER TAKE-OFF
Poulie de prise de force

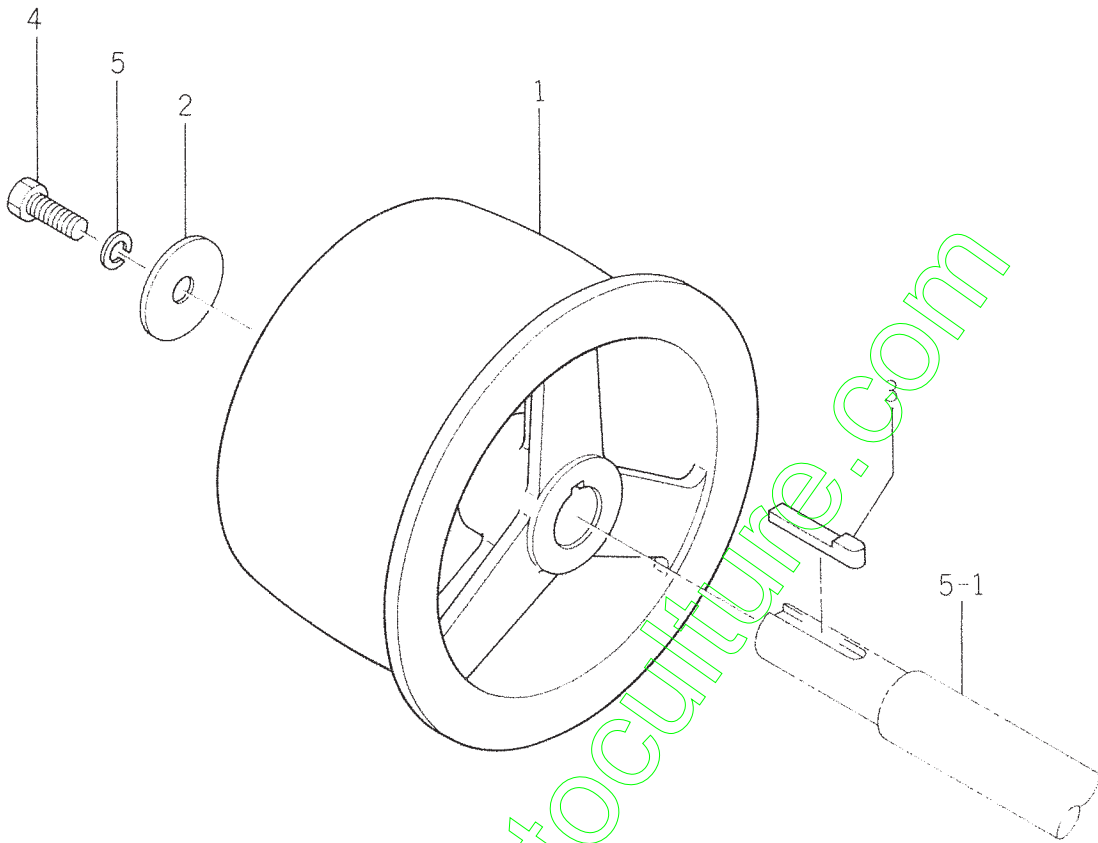

Ref No. Réf N°.	Parts No. Pièces N°.	Description Désignation	Qty Quant				Remarks Remarques
			2E 40	2RE 40	E 40	RE 40	
14- 1	1350-917-001-00	PULLEY/115 Poulie	1		1		★
14- 2	1350-701-006-00	WASHER Rondelle	1		1		★
14- 3	1329-201-003-00	KEY Clavette	1		1		★
14- 4	V200-260-601-60	BOLT/M6×16 Vis	1		1		★
14- 5	V401-260-006-00	WASHER, SP/M6 Rondelle frein	1		1		★



**Yvan Béal - 21, av. de l'Agriculture - B.P. 16
Z.I. du Brézet - 63014 Clermont-Ferrand Cedex 2
Tél : 04 73 91 93 51 - Télécopie : 04 73 90 23 11
www.yvanbeal.fr - E-mail : info@yvanbeal.fr
R.C.S. Clermont-Fd B 304 973 886 - S.A.S. au capital de 612 000 €**