

ILLUSTRATED PARTS BREAKDOWN

**BERNARD
12.5 HP 36" LAWN TRACTOR
MODEL NO. BL12536SB (BL12536SBB)
PRODUCT NO. 964 77 12-00**

www.emc-motoculture.com

REPAIR PARTS

TRACTOR - - MODEL NO. BL12536SB (BL12536SBB), PRODUCT NO. 964 77 12-00
ELECTRICAL

KEY NO.	PART NO.	DESCRIPTION
1	163465	Battery 12 Volt 25 AMP
2	74760412	Bolt Hex Hd 1/4-20unc X 3/4
8	176689	Case Battery
16	176138	Switch Interlock Push-In
24	4799J	Cable Battery
25	146147	Cable Battery 6 Ga 44" red
26	175158	Fuse 20 AMP
27	73510400	Nut Keps Hex 1/4-20 Unc
28	4207J	Cable Ground 6 Ga 12" black
29	121305X	Switch Plunger No Gray
30	175567	Switch Ign
33	140401	Key Ign
40	179730	Harness Ignition
41	71110408	Bolt Blk Fin Hex 1/4 - 20 x 1/2
42	131563	Cover Terminal Red
43	178861	Solenoid
48	140844	Adapter Ammeter
52	141940	Protection Wire Loop
89	180449	Cover Terminal Battery

NOTE: All component dimensions give in U.S. inches
1 inch = 25.4 mm.

REPAIR PARTS

TRACTOR - - MODEL NO. BL12536SB (BL12536SBB), PRODUCT NO. 964 77 12-00
CHASSIS AND ENCLOSURES

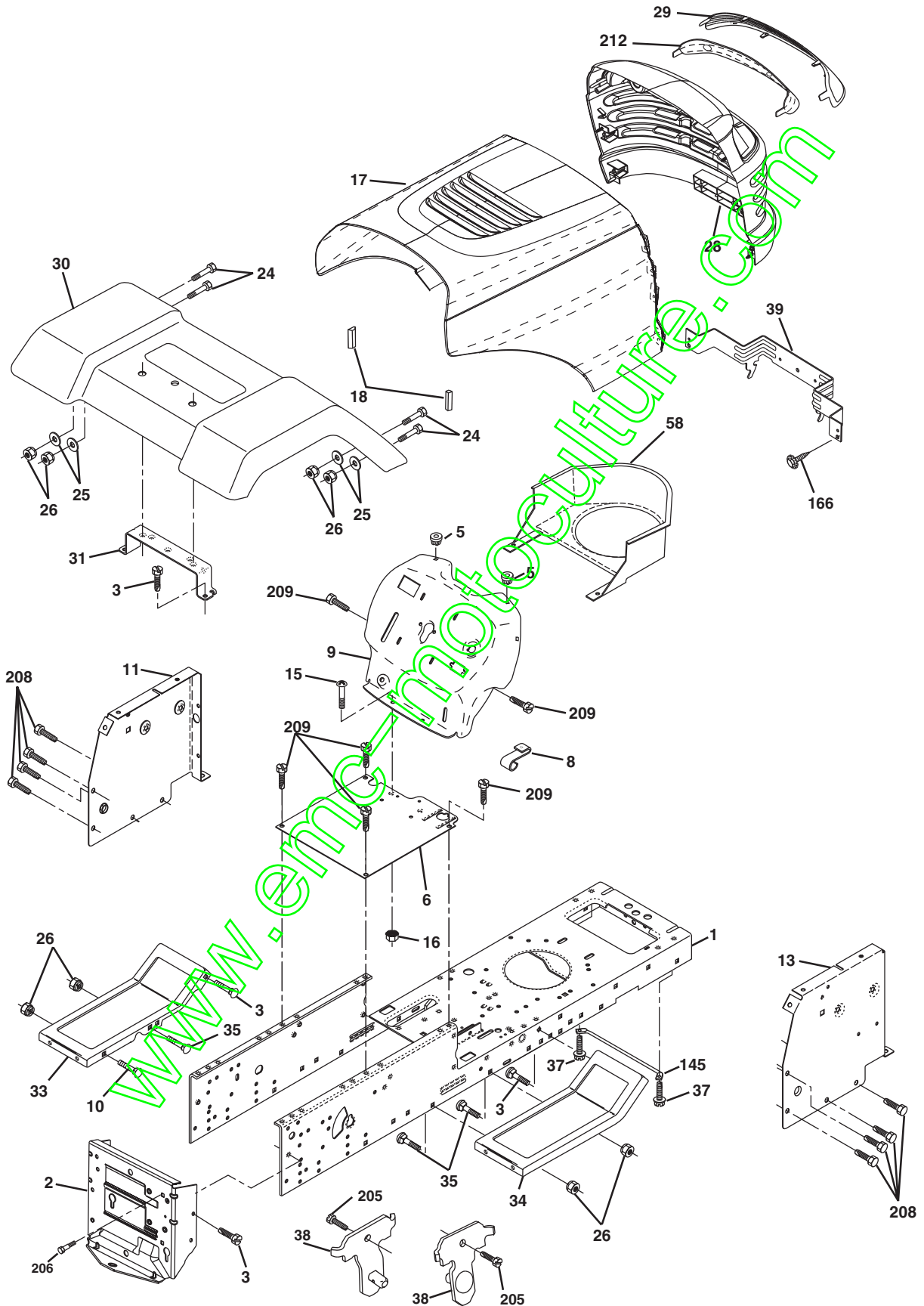

REPAIR PARTS

TRACTOR - - MODEL NO. BL12536SB (BL12536SBB), PRODUCT NO. 964 77 12-00
CHASSIS AND ENCLOSURES

KEY NO.	PART NO.	DESCRIPTION
1	174620	Chassis
2	176554	Drawbar
3	17060612	Screw, 3/8-16 x 3/4 SMGML Tap/R
5	155272	Bumper Hood/Dash
6	174643X012	Saddle Flat
8	155138	Clip Retainer Slide-On
9	168347X011	Dash P/L
10	72140608	Bolt, Rdhd Sqnk 3/8-16 x 1
11	174996	Panel Asm. Dash LH
13	172107X010	Dash, Panel RH
15	74180512	Screw Mach. Thrd 5/16-18 UNC x 3/4
16	73510500	Nut Keps 5/16-18 UNC
17	174330X421	Hood Pnt Laser Lt
18	126938X	Bumper Hood
24	74780616	Bolt, Hex, Fin. 3/8-16UNC x 1 Gr. 5
25	19131312	Washer 13/32 x 13/16 x 12 Gauge
26	73800600	Nut Lock Hex w/Ins. 3/8-16 Unc
28	179750	Grille
29	174332X428	Lens Grille
30	169465X421	Fender Pnt
31	136619	Bracket Fender
33	179716X418	Footrest Pnt., LH
34	179717X418	Footrest Pnt., RH
35	72110606	Bolt Rdhd Sht. Sqnk 3/8-16 X 3/4
37	17490508	Screw Thdrol 5/16-18 x 1/2 Tyt
38	175710	Bracket Asm Pivot Mower Rear
39	174714	Bracket Pivot Laser Lt
58	150127	Duct Air Engine
145	156524	Rod Pivot Chassis/Hood
166	164863	Screw Hwhd Hi-Lo #13-16 x 3/4
205	17490608	Screw 3/8-16 x 1/2
206	179165	Bolt Shoulder 5/16-18
208	17670608	Screw Thdrol 3/8-16 x 1/2
209	17000612	Screw Hexwsh Thdr 3/8-16 x 3/4
212	175143	Lens Insert
-	5479J	Plug Btn Blk .359 Dia Ch/Inf

NOTE: All component dimensions given in U.S. inches
1 inch = 25.4 mm

REPAIR PARTS

TRACTOR - - MODEL NO. BL12536SB (BL12536SBB), PRODUCT NO. 964 77 12-00
DRIVE

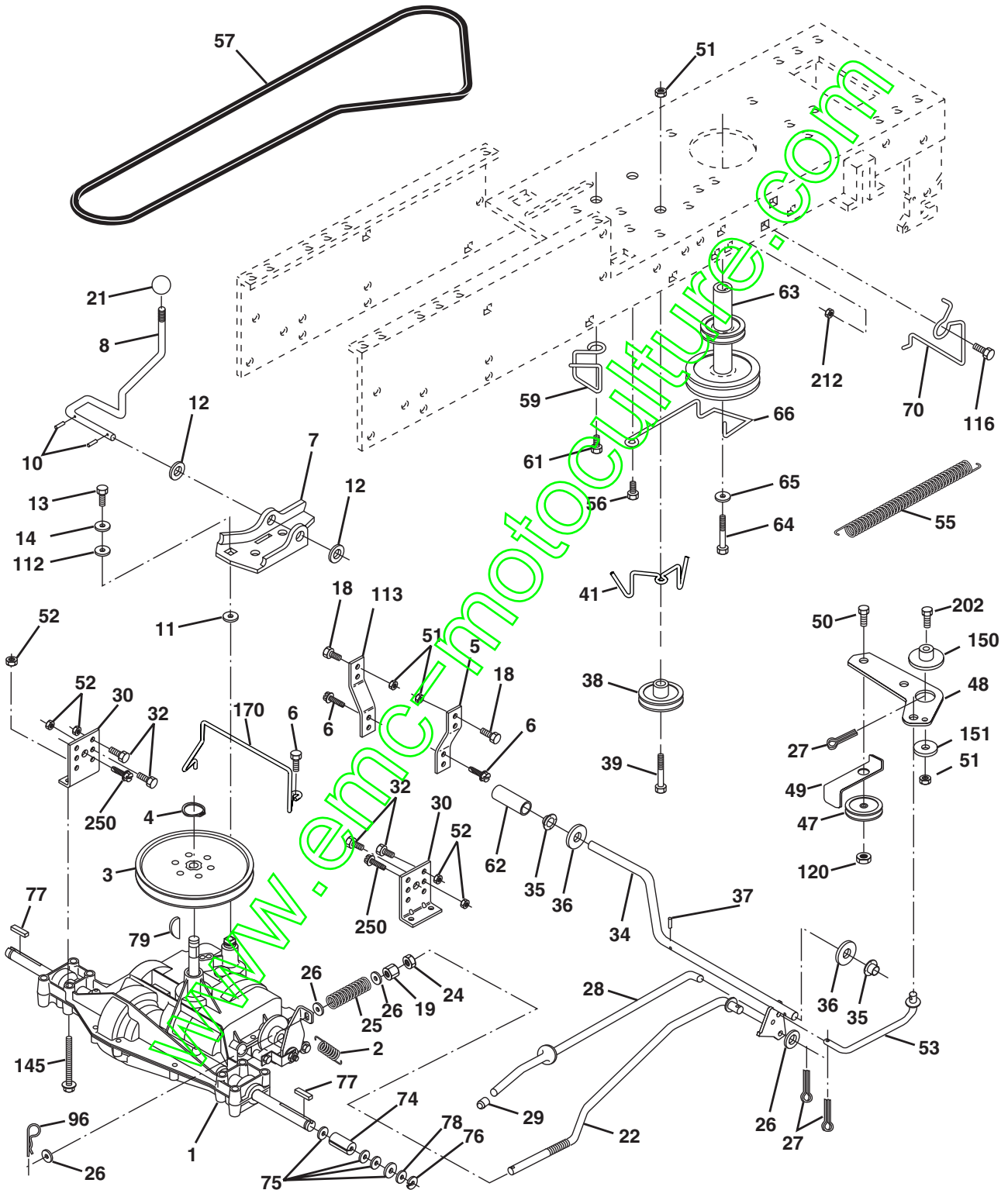

REPAIR PARTS

TRACTOR - - MODEL NO. BL12536SB (BL12536SBB), PRODUCT NO. 964 77 12-00
DRIVE

KEY NO.	PART NO.	DESCRIPTION	KEY NO.	PART NO.	DESCRIPTION
1	-----	Transaxle (See Breakdown) Peerless, Model 204-506B (Order parts from transaxle manufacturer)	50	74760624	Bolt, Hex 3/8-16 x 1-1/2
2	146682	Spring, Brake Return	51	73680600	Nut, Crownlock 3/8-16
3	123666X	Pulley, Transaxle	52	73680500	Nut, Crownlock 5/16-18
4	12000028	Ring, Retainer	53	105710X	Link, Clutch
5	121520X	Strap, Torque	55	105709X	Spring, Return, Clutch
6	17060512	Screw, 5/16-18 x 3/4 SMGML	56	17060620	Bolt, Fin Hex 3/8-16unc x 1-1/2
7	162240	Bracket, T/A, Saddle Shift	57	130801	V-Belt, Drive
8	131679	Rod, Shifter	59	169691	Keeper, Belt Center Span
10	76020416	Pin, Cotter 1/8 x 1	61	17120614	Screw, 3/8-16 x 3/4 SMGML
11	105701X	Washer, Shift Plate	62	8883R	Cover, Foot Pedal
12	19151216	Washer 15/32 x 3/4 x 16	63	180219	Pulley, Engine
13	74550412	Bolt 1/4-28 UNF Gr. 8 w/Patch	64	71170764	Bolt, Hex 7/16-20 x 4 Gr. 5
14	10040400	Washer Lock	65	10040700	Washer, Lock Hvy Hlcl Spr 7/16
18	74780616	Bolt, Fin Hex 3/8-16 Unc x 1 Gr.	66	154778	Keeper, Belt Engine F-Proof
19	73800600	Locknut 3/8-16	70	180218	Guide Belt Mower Drive RH
21	106933X	Knob	74	137057	Spacer, Split
22	130804	Rod, Brake	75	121749X	Washer 25/32 x 1-1/4 x 16 Ga.
24	73350600	Nut, Hex Jam 3/8-16	76	12000001	E-Ring
25	106888X	Spring, Rod, Brake	77	123583X	Key Square
26	19131316	Washer 13/32 x 13/16 x 16 Gauge	78	121748X	Washer 25/32 x 1-5/8 x 16 Ga.
27	76020412	Pin, Cotter 1/8 x 3/4	79	2228M	Key Woodruff #9 3/16 x 3/4
28	175765	Rod, Brake, Park	96	4497H	Retainer Spring 1" Ziinc/Cad
29	71673	Cap, Plunger	112	19091210	Washer 9/32 x 3/4 x 10 Ga.
30	174973	Bracket, Transaxle	113	127285X	Strap Torque L.H. Lt
32	74760512	Bolt Hex Hd 5/16-18 UNC x 3/4	116	72140608	Bolt, RdHd Sq Neck 3/8-16 x 1.25
34	175578	Shaft, Foot Pedal	120	73900600	Nut Lock 3/8-16
35	120183X	Bearing Nylon	145	74490540	Bolt, Hex Flghd 5/16-18 Gr. 5
36	19211616	Washer 21/32 x 1 x 16 Gauge	150	175456	Spacer Retainer
37	1572H	Pin, Roll 3/16 x 1	151	19133210	Washer 13/32 x 2 x 10 Ga.
38	179114	Idler, Pulley Composite	170	178394	Keeper, Belt TA PMST/DANA
39	74760648	Bolt Fin Hex 3/8-16 x 2-3/4	202	72110614	Bolt Carr Sh 3/8-16 x 1-3/4 Gr. 5
41	175556	Keeper, Belt	212	145212	Nut Hex Flange Lock
47	127783	Pulley, Idler	250	17060612	Screw 3/8-16 x .75
48	154407	Bellcrank Asm Clutch			
49	123205X	Retainer, Belt			

NOTE: All component dimensions give in U.S. inches.
1 inch = 25.4 mm.

www.emc-motocycle.com

REPAIR PARTS

TRACTOR - - MODEL NO. BL12536SB (BL12536SBB), PRODUCT NO. 964 77 12-00
SEAT

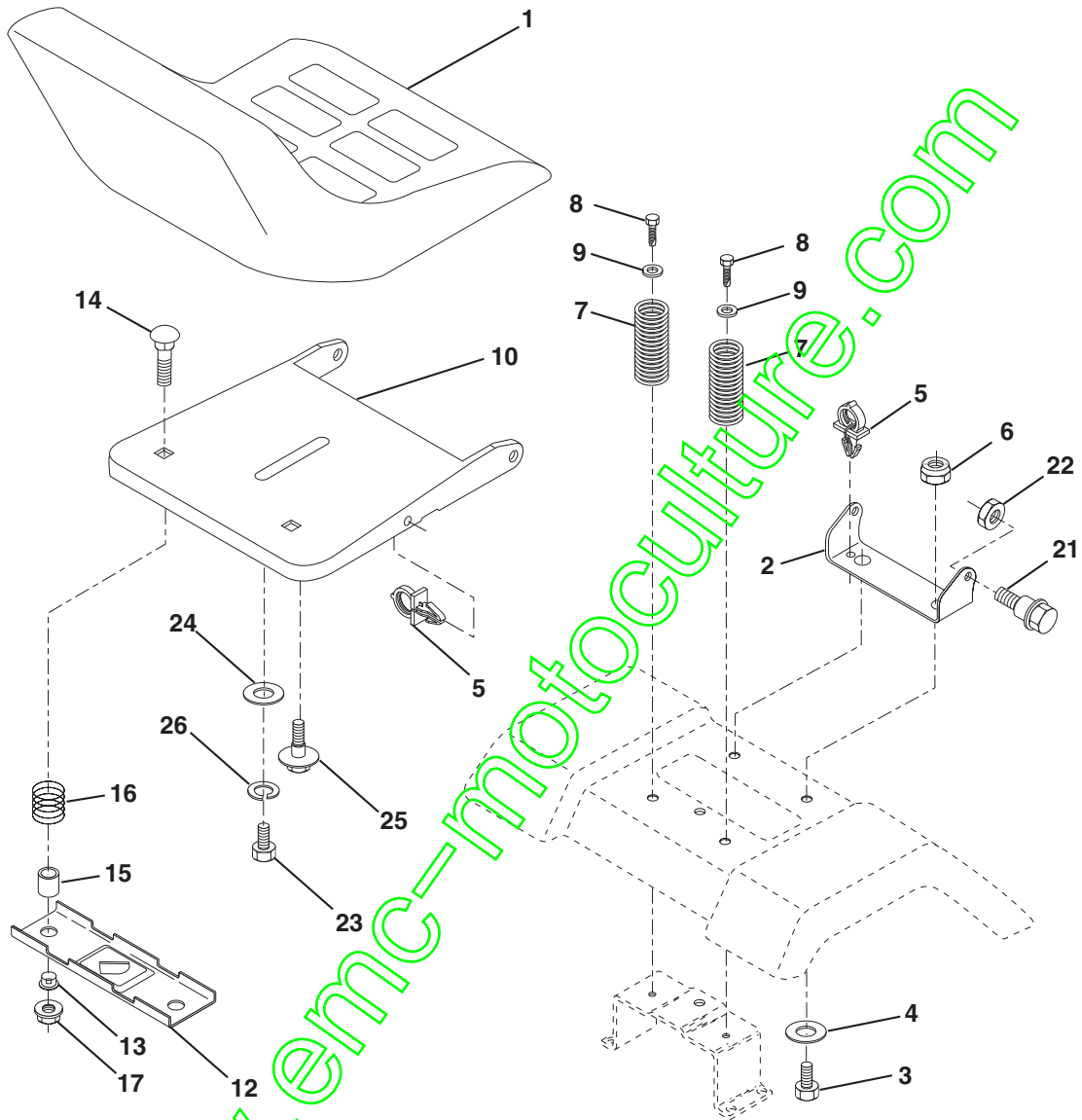

KEY NO.	PART NO.	DESCRIPTION
1	175389	Seal
2	140551	Bracket, Pivot, Seat
3	71110616	Fin Hex 3/8-16unc x 1
4	19131610	Washer 13/32 x 1 x 10 Ga.
5	145006	Clip, Push-in
6	73800600	Nut
7	124181X	Spring, Seat
8	17000616	Screw, 3/8-16 x 1.5 SMGML Tap/R
9	19131614	Washer 13/32 x 1 x 14 Ga.
10	174894	Pan, Seat
12	121246X	Bracket, Mounting, Switch, Seat
13	121248X	Bushing, Nylon

KEY NO.	PART NO.	DESCRIPTION
14	72050412	Nut, Crownlock 1/4-20 x 1-3/8
15	134300	Spacer, Split
16	121250X	Spring
17	123976X	Nut, Lock, Flange 1/4 Gr. 5
21	171852	Bolt, Shoulder 5/16-18 UNC-2A
22	73800500	Nut
23	71110814	Bolt Hex
24	19171912	Washer 17/32 x 1-3/16 x 12 Ga.
25	127018X	Bolt Shoulder 5/16-18 x .62
26	10040800	Washer Lock Hvy Hclc Spr 1/2

NOTE: All component dimensions given in U.S. inches
1 inch = 25.4 mm

REPAIR PARTS

TRACTOR - - MODEL NO. BL12536SB (BL12536SBB), PRODUCT NO. 964 77 12-00

DECALS

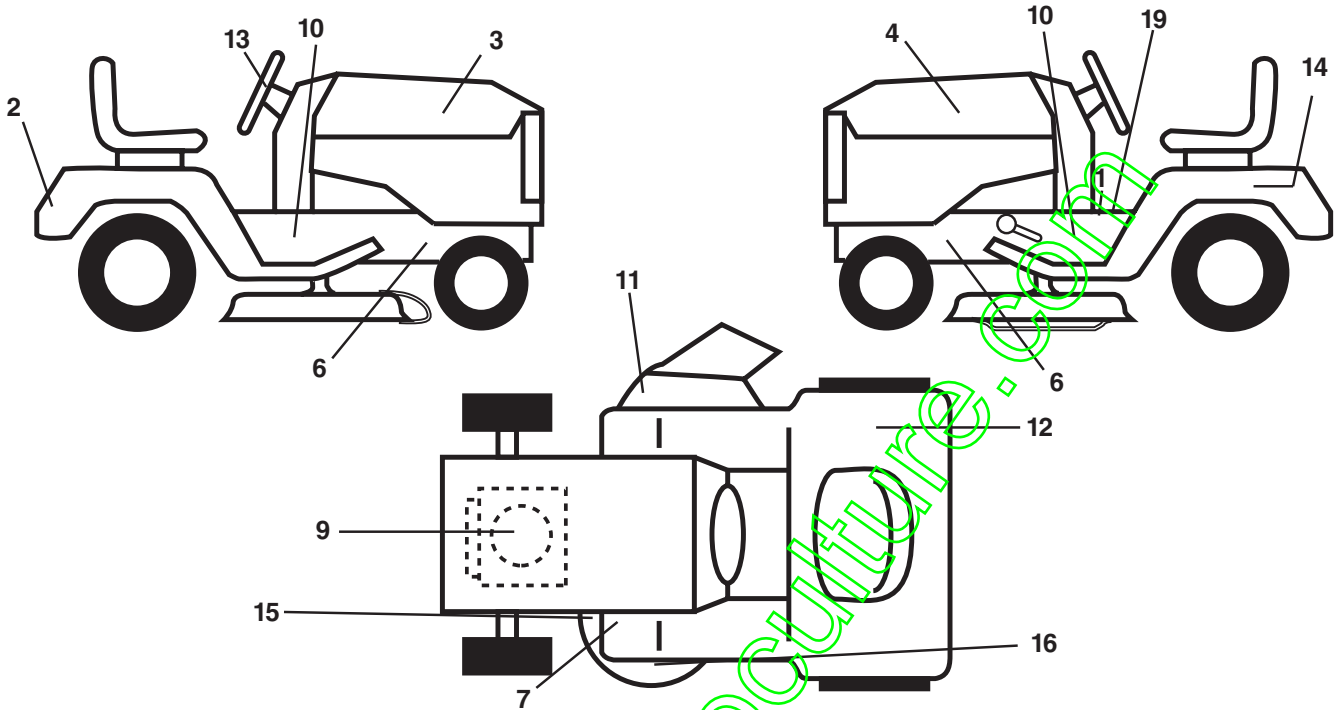

KEY NO.	PART NO.	DESCRIPTION	KEY NO.	PART NO.	DESCRIPTION
1	145498	Decal, Instruction, Operation	12	180432	Decal 100 DBA
2	166708	Decal, Fender	13	166285	Decal, Wheel Steering
3	179706	Decal, Hood RH	14	145005	Decal, Btry Dngr/Psn P/L Sym
4	179707	Decal, Hood LH	15	136832	Decal, V-Belt
6	159736	Decal, Chassis Hot Muffler	16	134999	Decal, Deck
7	159737	Decal, Brake/Clutch Symbol LT	19	140837	Decal, Parking Brake
9	170841	Decal, HP Engine	--	138311	Decal, Handle, Lift, Height Adjust (Lift Handle)
10	179708	Decal, Chassis	--	162598	Decal, Drawbar Load Limit
11	145494	Decal, Mower Cutfinger Symbol	--	181724	Manual, (Euro) Operator's

TIRES AND WHEELS

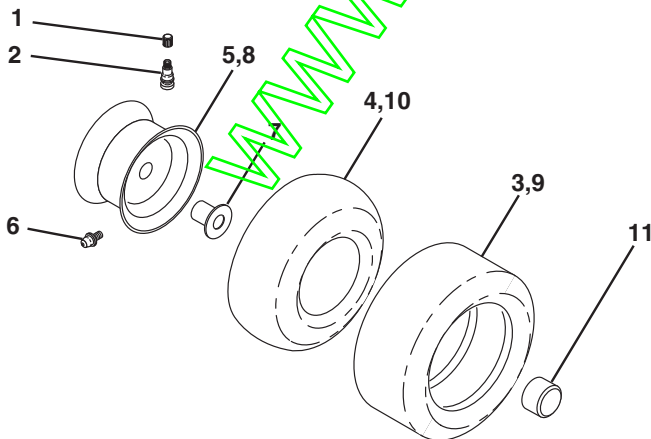

KEY NO.	PART NO.	DESCRIPTION
1	59192	Cap, Valve
2	65139	Stem, Valve
3	124157X	Tire Front
4	59904	Tube, Front (not furnished)
5	106732X421	Rim, Asm. Front
6	278H	Grease Fitting (rear tire only)
7	9040H	Bearing, Flange (front tire only)
8	106108X421	Rim, Asm. Rear
9	123969X	Tire, Rear
10	7152J	Tube, Rear (not furnished)
11	104757X428	Cap, Axle
--	144334	Sealant, Tire (10 oz. Tube)

NOTE: All component dimensions given in U.S. inches
1 inch = 25.4 mm

REPAIR PARTS

TRACTOR - - MODEL NO. BL12536SB (BL12536SBB), PRODUCT NO. 964 77 12-00
STEERING WHEEL

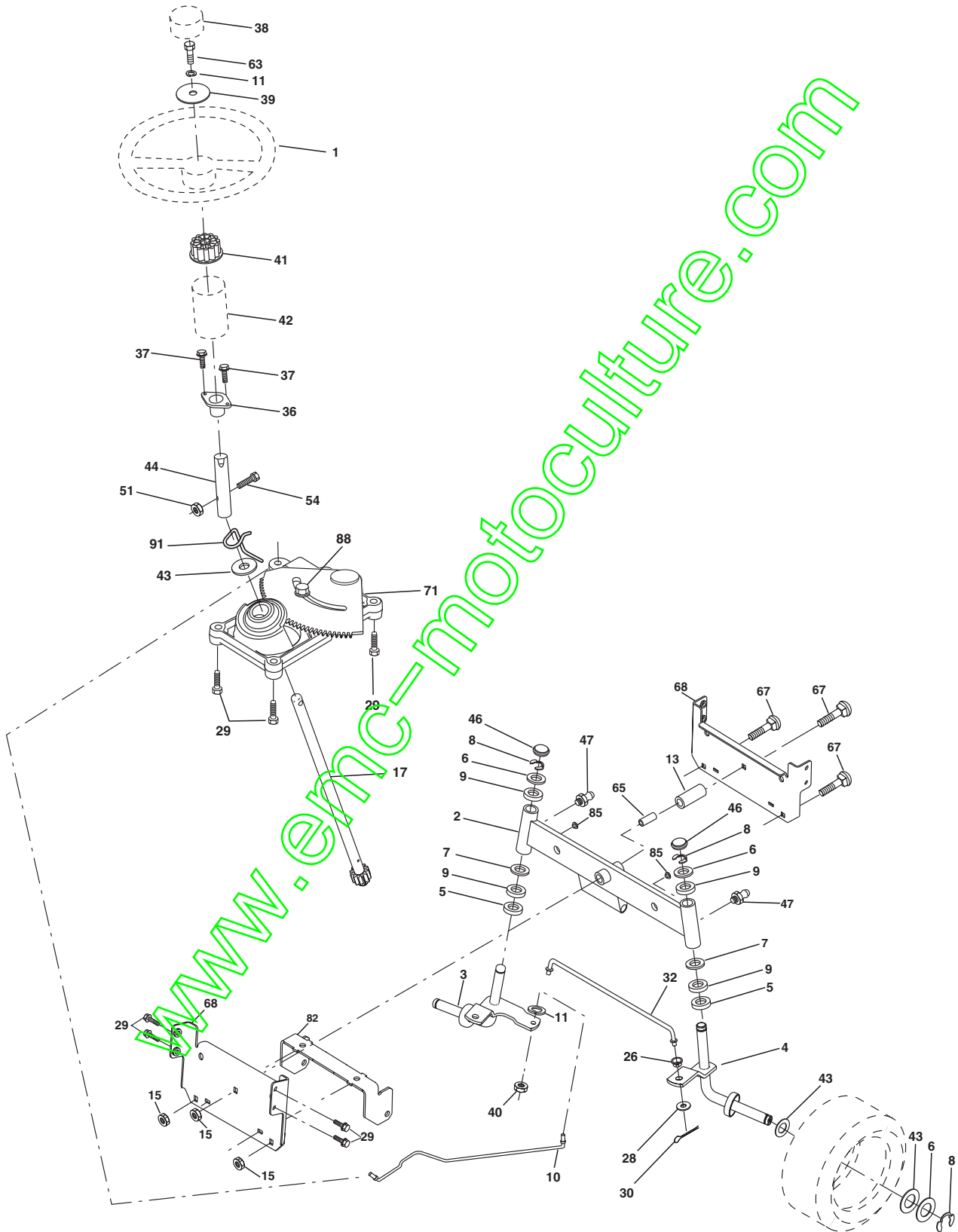

REPAIR PARTS

TRACTOR - - MODEL NO. BL12536SB (BL12536SBB), PRODUCT NO. 964 77 12-00

STEERING WHEEL

KEY NO.	PART NO.	DESCRIPTION
1	139768	Wheel Steering
2	175131	Axle Asm Front
3	169840	Spindle Asm LH
4	169839	Spindle Asm RH
5	6266H	Bearing, Race, Thrust Hardened
6	121748X	Washer 25/32 X 1-5/8 X 16 Ga
7	19272016	Washer 27/32 X 1-1/4 X 16 Ga
8	12000029	Ring Klip
9	3366R	Bearing
10	175121	Link Drag
11	10040600	Washer Lock Hvy Hlcl Spr 3/8
13	136518	Spacer Brg. Axle Front
15	145212	Nut Hexflange Lock
17	177876	Steering, Assembly Shaft
26	126847X	Bushing Link Drag Blk Lr
28	19131416	Washer 13/32 x 7/8 x 16 Ga.
29	17060612	Screw 3/8-16x3/4 SMGML Tap/R
30	76020412	Pin Cotter 1/8 x 3/4 CAD
32	130465	Rod Connecting
36	155099	Bushing Steering
37	152927	Screw TT #10-32 X 5 x 3/8 Flange
38	140175	Cap Wheel Steering
39	19133812	Washer 13/32 x 2-3/8 x 12 Ga
40	7810H	Nut Lock Center 3/8-24 Unf
41	100711L	Adapter Wheel Strg
42	145054X428	Boot Steering
43	121749X	Washer 25/32 X 1 1/4 X 16 Ga
44	153720	Extension Steering
46	121232X	Cap Spindle
47	6855M	Fitting Grease
51	73800500	Nut Lock Hex W/Ins. 5/16-18 Unc P
54	74780520	Bolt Fin Hex 5/16-18 Unc 6 x 1-1/4
63	74780616	Bolt Fin Hex 3/8-16unc x 1 Gr. 5
65	160367	Spacer Brace Axle
67	72140618	Bolt RDHD SQ 3/8-16UNC x 2-1/4
68	169827	Brace Axle
71	175146	Steering Asm.
82	169835	Bracket Susp. Chassis Front
85	133835	Fastener Christmas Tree
88	175118	Bolt Shoulder
91	175553	Clip Steering

NOTE: All component dimensions given in U.S. inches
1 inch = 25.4 mm

REPAIR PARTS

TRACTOR - - MODEL NO. BL12536SB (BL12536SBB), PRODUCT NO. 964 77 12-00
ENGINE

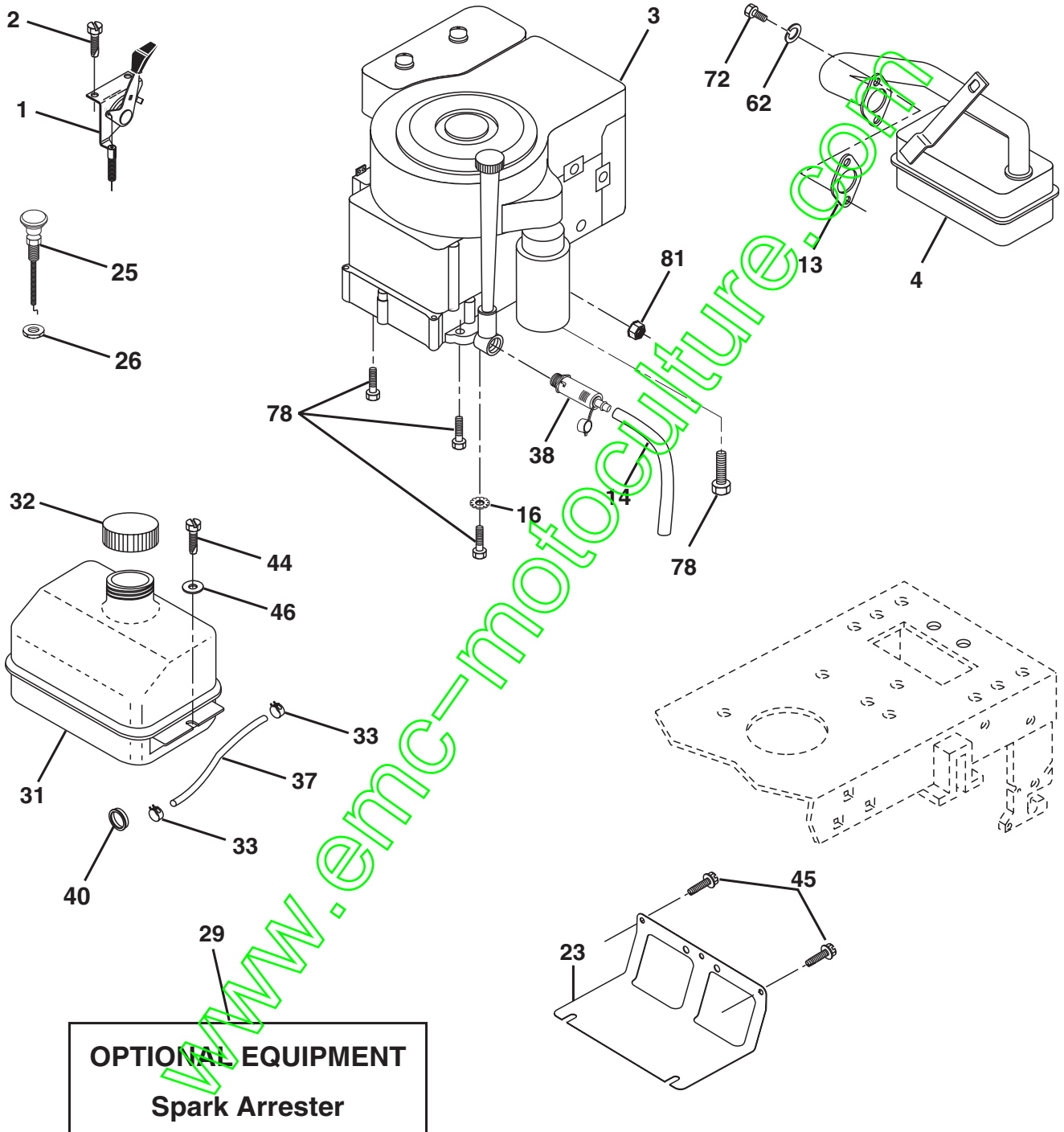

REPAIR PARTS

TRACTOR - - MODEL NO. BL12536SB (BL12536SBB), PRODUCT NO. 964 77 12-00
ENGINE

KEY NO.	PART NO.	DESCRIPTION
1	170551	Control Th/ch
2	17720408	Screw Hex Thd Cut 1/4-20x5/8 T
3	-----	Engine, B&S, 289707 Order parts from engine manufacturer
4	137348	Muffler
13	165291	Gasket
14	148456	Tube Drain Oil Easy
16	11050600	Washer Lock Ext Tooth 3/8
23	169837	Shield BRN/DBR Guard
25	180945	Control Choke
26	73920600	Nut Keps 3/8-24 Unf
29	137180	Kit Spark Arrestor (Flat Scrn)
31	109202X	Tank Fuel Front
32	140527	Cap Asm Fuel
33	123487X	Clamp Hose Blk
37	137040	Line Fuel
38	148315	Plug Drain Oil Easy
40	124028X	Bushing Snap Nyl Blk Fuel Line
44	17670412	Screw Hex Wsh Thdrol 1/4-20x3/4
45	17000612	Screw Hex Wsh Thdrol 3/8-16
46	19091416	Washer 9/32 X 7/8 X 16 Ga
62	10040500	Washer 5/16
72	71070512	Screw Hex Hd Cap 5/16-18 x 3/4
78	17060620	Screw 3/8-16x1-1/4 SMGML Tap/R
81	73510400	Nut Keps Hex 1/4-20 UNC

NOTE: All component dimensions given in U.S. inches.
1 inch = 25.4 mm.

REPAIR PARTS

TRACTOR - - MODEL NO. BL12536SB (BL12536SBB), PRODUCT NO. 964 77 12-00
MOWER LIFT

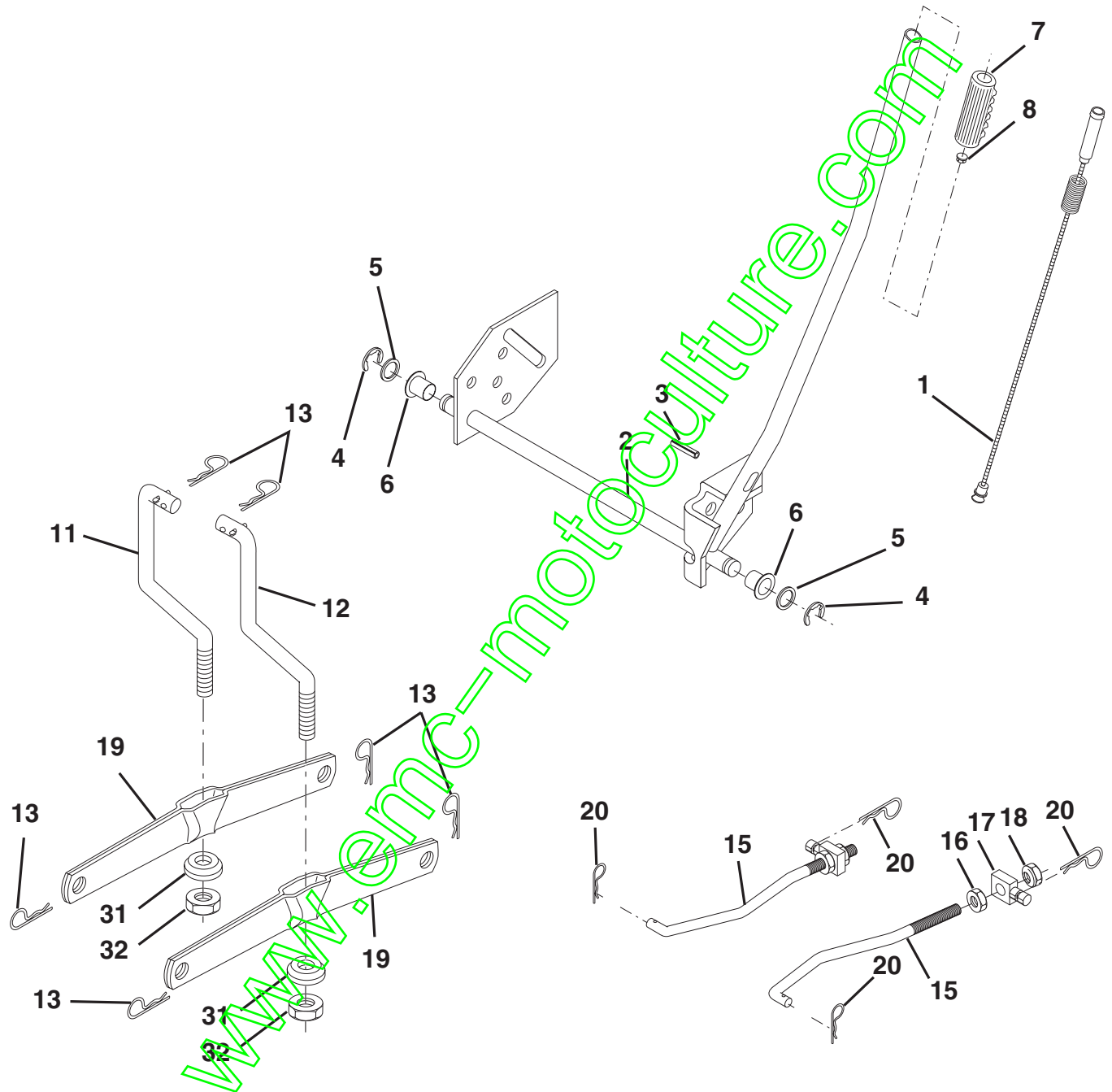

REPAIR PARTS

TRACTOR - - MODEL NO. BL12536SB (BL12536SBB), PRODUCT NO. 964 77 12-00
MOWER LIFT

KEY NO.	PART NO.	DESCRIPTION
1	159460	Wire Asm. Inner/Sprg w/Plunger
2	159471	Shaft, Asm., Lift R/H
3	105767X	Pin, Groove
4	12000002	Ring, E #5133-62
5	19211621	Washer 21/32 x 1 x 21 Ga.
6	120183X	Bearing, Nylon
7	109413X	Grip Handle Bicycle Matte Blk
8	124526X	Button, Plunger
11	139865	Link, Lift, Lh
12	139866	Link, Lift, Rh
13	4939M	Spring, Retainer
15	173288	Link, Front
16	73350800	Nut, Jam, Hex 1/2-13 Unc
17	175689	Trunnion
18	73800800	Nut, Crownlock 1/2-13 Unc
19	139868	Arm, Suspension, Rear
20	163552	Spring, Retainer Zinc
31	169865	Bearing, Pvt Lft
32	73540600	Nut Crownlock 3/8-24

NOTE: All component dimensions given in U.S. inches
1 inch = 25.4 mm

REPAIR PARTS

TRACTOR - - MODEL NO. BL12536SB (BL12536SBB), PRODUCT NO. 964 77 12-00
MOWER DECK

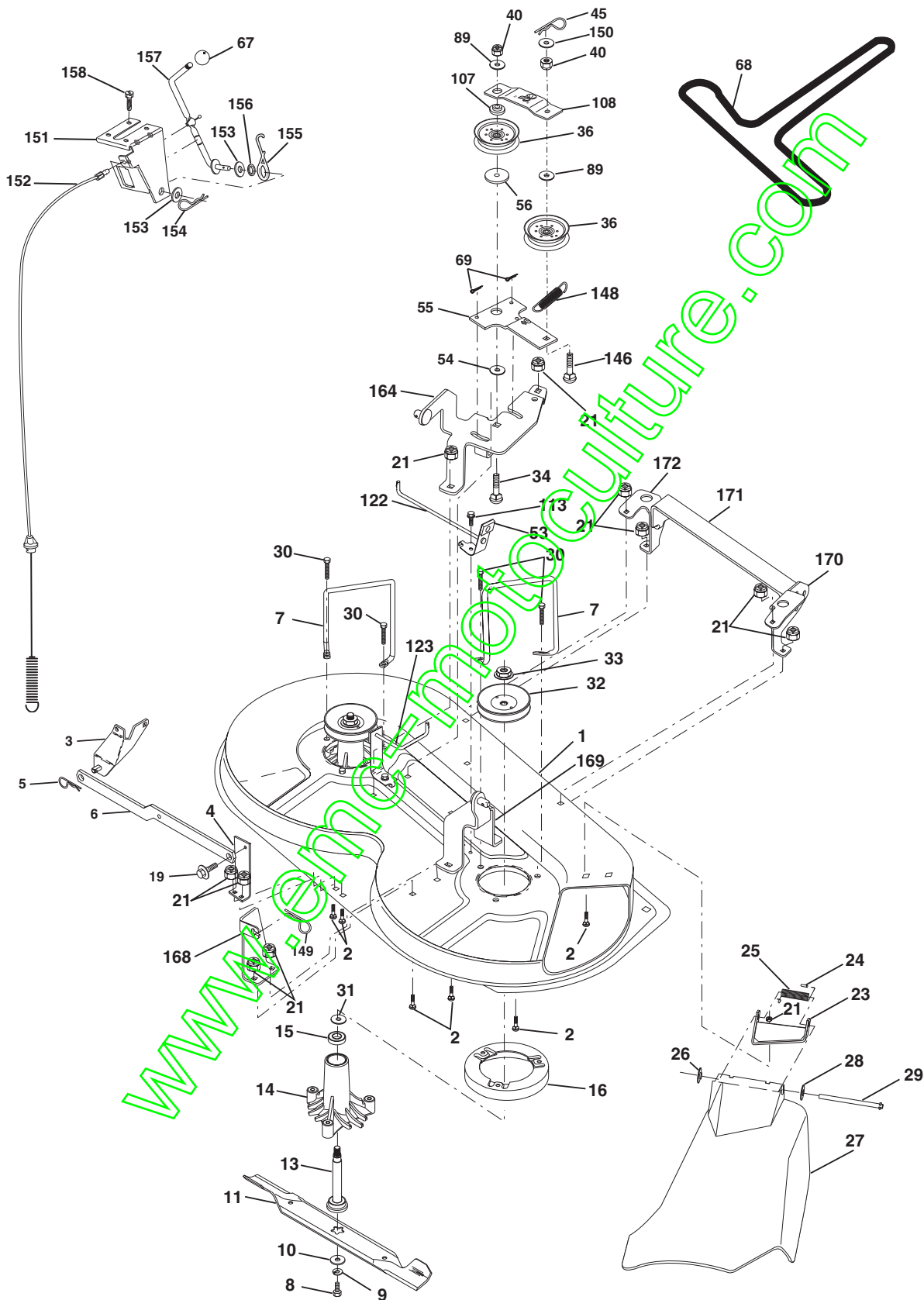

REPAIR PARTS

TRACTOR - - MODEL NO. BL12536SB (BL12536SBB), PRODUCT NO. 964 77 12-00

MOWER DECK

KEY NO.	PART NO.	DESCRIPTION	KEY NO.	PART NO.	DESCRIPTION
1	174595	Mower Deck Assembly	56	165723	Spacer, Retainer
2	72140506	Bolt	67	106932X	Knob RD 3/8-16 Plstc Thd
3	138017	Bracket Assembly, Sway Bar	68	180213	Belt
4	175654	Bracket Sway Bar	69	76020312	Pin, Cotter 3/32 x 3/4
5	4939M	Retainer Spring	89	19131612	Washer 13/32 x 1 x 12 Ga
6	178024	Bar, Sway Deck	107	133502	Spacer, Retainer
7	140608	Keeper Belt	108	133503	Stiffener, Idler Arm
8	850857	Bolt, Hex 3/8-24 x 1.25 Gr. 8	113	17490508	Screw Thdrol 5/16-18 x 1/2
9	10030600	Washer, Lock Hvy Hlcl 3/8	122	174505	Rod, Brake, LH
10	140296	Washer, Hardened	123	174504	Rod, Brake, RH
11	138496	Blade, Mower	146	165891	Bolt Carriage Idler
13	137645	Shaft Assembly, Mandrel, Vented	148	169022	Spring Return Idler
14	128774	Housing, Mandrel, Vented	149	165898	Retainer Spring Yellow Zinc
15	110485X	Bearing, Ball, Mandrel	150	10091216	Washer 9/32 x 3/4 x 16 Ga.
16	174493	Stripper, Vented Mower Deck	151	169670	Bracket Clutch
19	132827	Bolt, Shoulder	152	176079	Cable Clutch
21	73680500	Nut Crownlock 5/16-18	153	169674	Washer Flat 3/8" Type B
23	136631	Bracket, Mower Deflector	154	169675	Spring Retainer
24	105304X	Cap, Sleeve	155	169671	Spring Retention Lever
25	123713X	Spring, Torsion, Deflector	156	169672	Spacer
26	110452X	Nut, Push	157	169669	Rod Clutch
27	175029X428	Shield, Deflector	158	17720408	Screw Hex Thd Cut 1/4-20x5/8
28	19111016	Washer 11/32 x 5/8 x 16 Ga.	154	174976	Bracket Asm Idler Support
29	121980X	Rod, Hinge	168	172377	Bracket Deck Cable
30	173984	Screw Thdrol Washer Head	169	174977	Bracket Asm Suspension
31	129963	Washer, Spacer	170	172359	Bracket Suspension RF
32	153531	Pulley, Mandrel	171	165237	Bracket Support Suspension Frt
33	178342	Nut, Toplock, Flanged	172	172355	Bracket Suspension LF
34	72110614	Bolt Rdhd 3/8-16 x 1-3/4	--	130794	Mandrel Assembly (Includes Housing, Shaft and Shaft Hardware Only - Pulley Not Included)
36	131494	Pulley, Idler, Flat	--	181376	Replacement Mower, Complete
40	73680600	Nut Crownlock 3/8-16			
45	4497H	Retainer, Spring			
53	130840	Brake Assembly			
54	133943	Washer, Hardened			
55	133840	Idler Arm Assembly			

NOTE: All component dimensions given in U.S. inches
1 inch = 25.4 mm

REPAIR PARTS

TRACTOR - - MODEL NO. BL12536SB (BL12536SBB), PRODUCT NO. 964 77 12-00

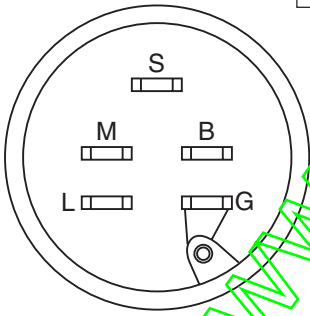
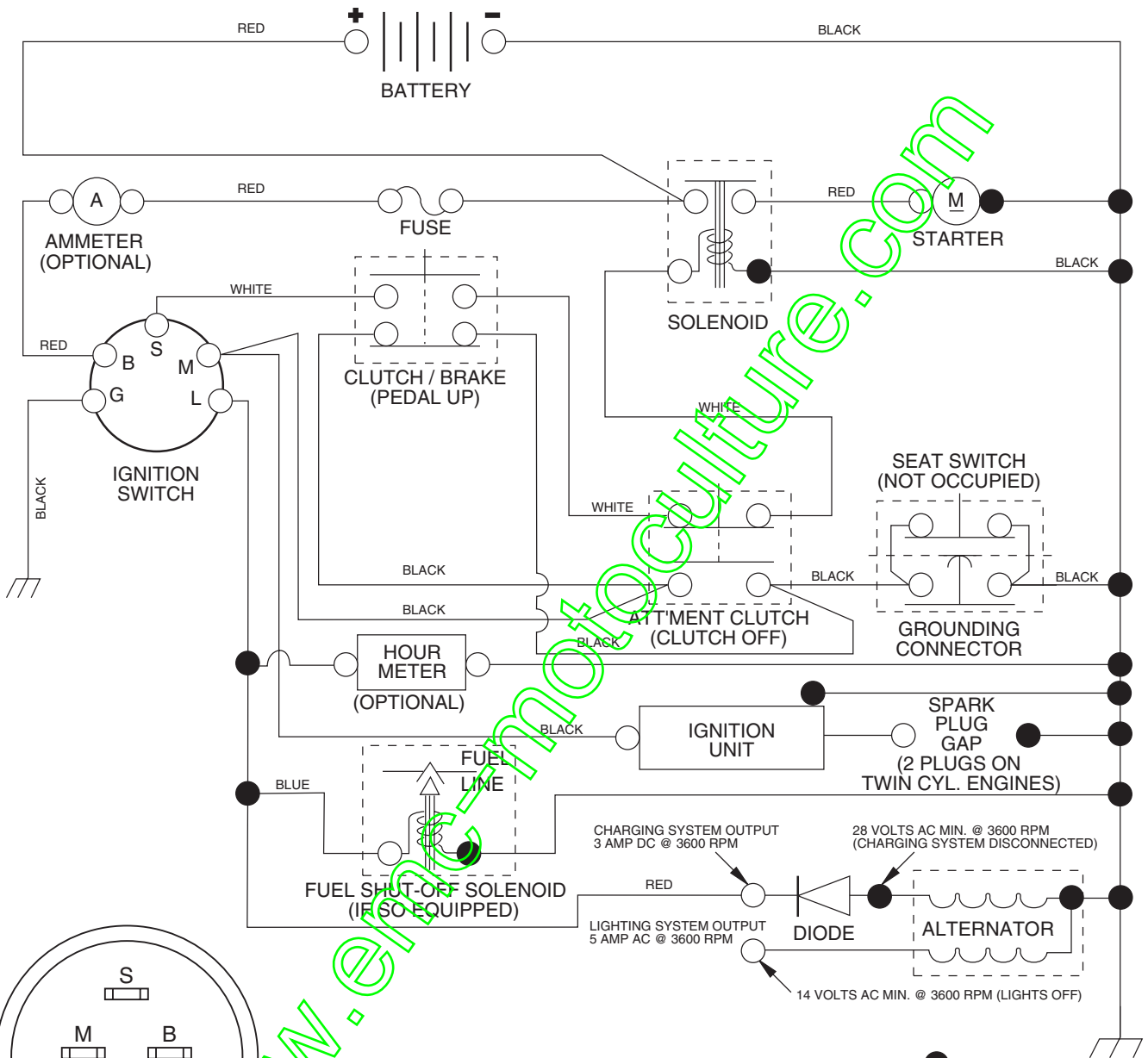

IGNITION SWITCH

POSITION	CIRCUIT
OFF	M + G
ON	B + L
START	B + S + L

WIRING INSULATED CLIPS
NOTE: IF WIRING INSULATED CLIPS WERE REMOVED FOR SERVICING OF UNIT, THEY SHOULD BE REPLACED TO PROPERLY SECURE YOUR WIRING.

