

ILLUSTRATED PARTS BREAKDOWN

BERNARD

13.5 HP 36" LAWN TRACTOR

MODEL NO. BL13536RB (BL13592RBA)

PRODUCT NO. 964 79 15-00

www.emc-motoculture.com

REPAIR PARTS

TRACTOR - - MODEL NO. BL13536RB (BL13592RBA), PRODUCT NO. 964 79 15-00
ELECTRICAL

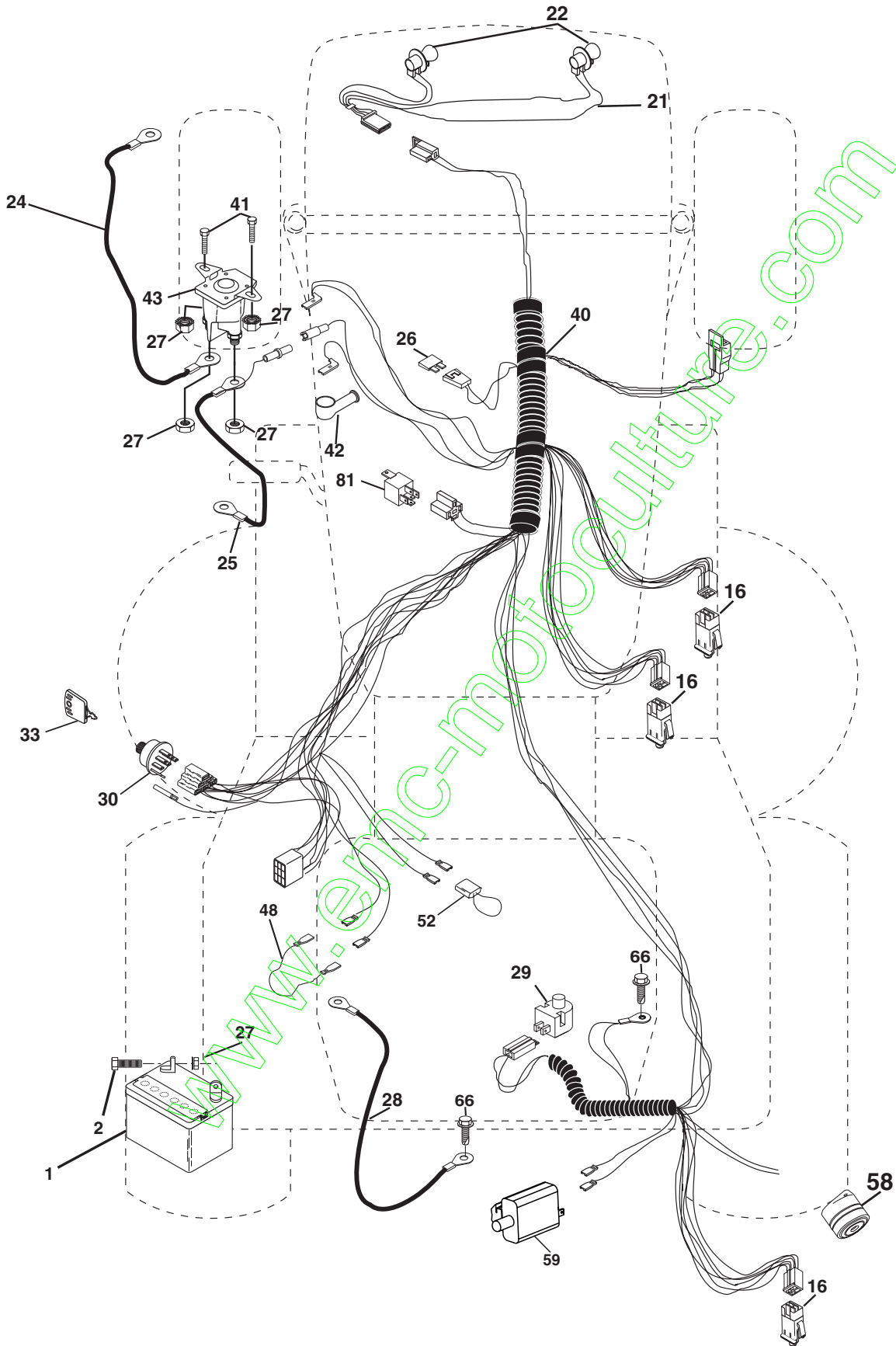

REPAIR PARTS

TRACTOR - - MODEL NO. BL13536RB (BL13592RBA), PRODUCT NO. 964 79 15-00
ELECTRICAL

KEY NO.	PART NO.	DESCRIPTION
1	532 16 34-65	Battery
2	874 76 04-12	Bolt Hex Hd 1/4-20 Unc X 3/4
16	532 17 61-38	Switch Interlock Push-In
21	532 17 56-88	Harness Asm. Light
22	532 00 41-52	Bulb Light #1156
24	532 12 47-80	Cable Starter 6 Ga 11" Red
25	532 16 59-87	Cable Battery Crd 56" Red
26	532 17 51-58	Fuse 20 Amp
27	873 51 04-00	Nut Keps Hex 1/4-20 Unc
28	532 12 77-25	Cable Ground 6 Ga 18" Black
29	532 16 07-84	Switch Plunger Normal Op Olive
30	532 17 55-66	Switch Ignition
33	532 14 04-01	Key Ign
40	532 17 97-28	Harness Ign
41	871 11 04-08	Bolt Flk Fin Hex 1/4-20 Unc X 1/2
42	532 13 15-63	Cover Terminal Red
43	532 17 88-61	Solenoid
48	532 14 08-44	Adapter Ammeter Rectangular
52	532 14 19-40	Protection Wire Loop
58	532 16 94-19	Buzzer Crd
59	532 18 03-79	Switch FBI CRD
66	817 49 06-08	Screw Thdrol 3/8-16 x 1/2 Ty-Tt
81	532 10 97-48	Relay Asm

NOTE: All component dimensions given in U.S. inches.
1 inch = 25.4 mm.

REPAIR PARTS

TRACTOR - - MODEL NO. BL13536RB (BL13592RBA), PRODUCT NO. 964 79 15-00
CHASSIS AND ENCLOSURES

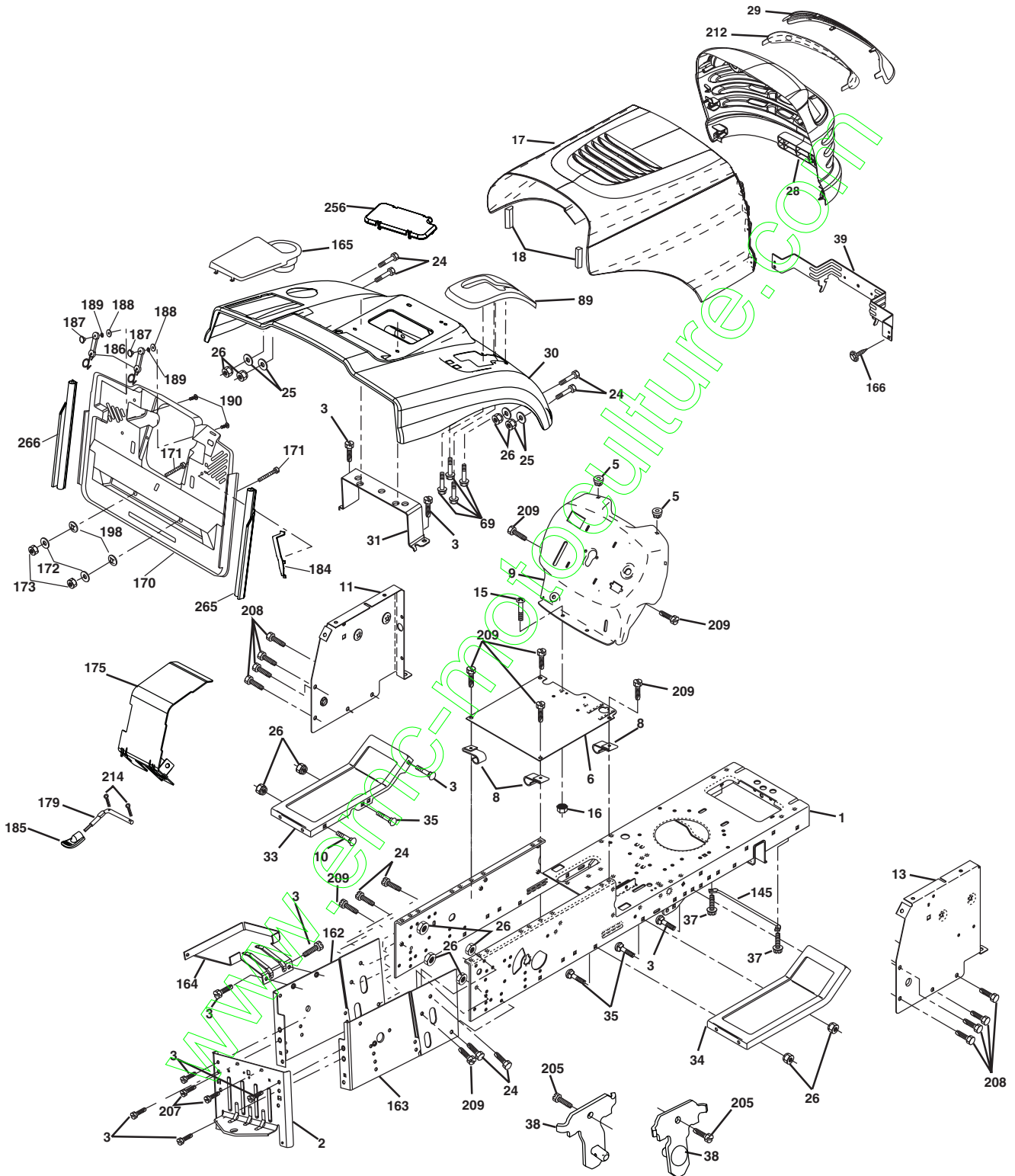

REPAIR PARTS

TRACTOR - - MODEL NO. BL13536RB (BL13592RBA), PRODUCT NO. 964 79 15-00 CHASSIS AND ENCLOSURES

KEY NO.	PART NO.	DESCRIPTION	KEY NO.	PART NO.	DESCRIPTION
1	532 17 46-20	Chassis	162	532 18 03-82	Bracket Exten Chassis Lh CRD
2	532 18 03-84	Drawbar	163	532 18 03-83	Bracket Exten Chassis Rh CRD
3	817 06 06-12	Screw 3/8-16 x .75	164	532 16 56-05	Support Battery CRD
5	532 15 52-72	Bumper Hood/Dash	165	532 18 13-56	Cover Battery CRD Lt
6	532 18 44-19	Saddle	166	532 17 18-75	Screw HWHD Hi Lo #13-16 x 3/4
8	532 12 64-71	Clip Insulator 13/32 Mtg. Hole	170	532 17 88-62	Backplate CRD
9	532 18 54-80	Dash	171	872 14 06-20	Bolt Rdhd Sqnk 3/8-16 x 2-1/2 G5
10	872 14 06-08	Bolt, Carriage 3/8-16 x 3/4	172	819 13 20-16	Washer 13/32 x 1-1/4 x 16 Ga.
11	532 17 49-96	Panel, Dash, L.H.	173	873 51 06-00	Nut, Keps Hex 3/8-16 UNC
13	532 18 17-19	Panel, Asm. Dash R.H.	175	532 18 03-10	Trap Door CRD
15	874 18 05-12	Screw, Machine, Truss Head 5/16-18 UNC x 3/4	179	532 18 03-76	Rod Pivot FBI CRD
16	873 51 05-00	Nut	184	532 17 46-62	Bracket Actuator Bagger CRD
17	532 18 29-07	Hood Assembly	185	532 18 11-01	Knob Rod
18	532 18 49-21	Bumper Hood	186	532 16 07-93	Latch Asm Multch Bagger
24	874 78 06-16	Bolt	187	532 12 50-04	Nut Weld .327/.304 #10-24
25	819 13 13-12	Washer 13/32 x 13/16 x 12 Gauge	188	819 06 12-16	Washer #10
26	873 80 06-00	Nut	189	810 07 10-00	Washer Lock #10
28	532 17 97-49	Grille Lens Asm	190	871 08 10-10	Screw Pan Hd Phillips 10-24 x 5/8
29	532 18 27-18	Lens	198	532 16 89-37	Nut Push
30	532 18 13-86	Fender	205	817 49 06-08	Screw 3/8-16 x 1/2
31	532 16 51-56	Bracket, Fender Support	207	817 67 05-08	Screw THDROL 5/16-18 x 1/2
33	532 18 10-57	Footrest, L.H.	208	817 67 06-08	Screw Thdrol 3/8-16 x 1/2
34	532 18 10-58	Footrest, R.H.	209	817 00 06-12	Screw Hex Wsh Thdrol 3/8-16 x 3/4
35	872 11 06-06	Bolt	212	532 17 51-43	Insert Lens Reflective
37	817 49 05-08	Screw Thdrol 5/16-18 x 1/2 TYT	214	532 12 47-88	Retainer Spring 1"
38	532 18 17-48	Bracket Asm Pivot Mower Rear	256	532 18 13-61	Cover Fender Rack CRD
39	532 17 47-14	Bracket Pivot Laser	265	532 18 57-04	Seal Side RH Bagger
69	532 14 24-32	Screw Hex 1/4-1/2	266	532 18 57-03	Seal Side LH Bagger
89	532 18 13-88	Console	--	532 00 54-79	Plug, Button
145	532 15 65-24	Rod Pivot Chassis/Hood			
161	532 16 46-55	Bumper Extrusion			

NOTE: All component dimensions given in U.S. inches.
1 inch = 25.4 mm.

REPAIR PARTS

TRACTOR - - MODEL NO. BL13536RB (BL13592RBA), PRODUCT NO. 964 79 15-00
DRIVE

KEY NO.	PART NO.	DESCRIPTION	KEY NO.	PART NO.	DESCRIPTION
1	-----	Transaxle Peerless 206-546 Order parts from transaxle manufacturer	79	532 12 50-96	Key Woodruff
2	532 14 66-82	Spring Brake Return	80	532 14 50-90	Arm Shift PMST 20" Tires
3	532 16 59-99	Pulley Transaxle	82	532 16 57-11	Spring Torsion
4	812 00 00-28	Ring Retainer #5100-62	83	819 17 12-16	Washer 17/32 x 3/4 x 16 Ga.
5	532 12 15-20	Strap torque 30 degrees	84	532 16 56-21	Link Shift CRD Pmst 18" Tires
6	817 06 05-12	Screw 5/16-18 x 3/4	96	532 12 47-88	Spring Retainer 1"
8	532 16 56-19	Rod Shift Fender Adjust Lt	112	819 09 12-10	Washer 9/32 x 3/4 x 10 Ga.
9	532 18 03-54	Clutch Noram	120	873 90 06-00	Nut Lock 3/8-16
10	876 02 04-16	Pin, Cotter 1/8 x 1	145	874 49 05-40	Bolt Hex FGHD 5/16-18 x Gr 5
11	532 10 57-01	Washer Plate Shf .3888 sq hole	150	532 16 58-50	Bushing, Bellcrank Grnd Dr
13	874 55 04-12	Bolt 1/4-28 Unf Gr 8 w/patch	151	819 13 32-10	Washer 13/32 x 2 x 10 Ga.
14	810 04 04-00	Washer, Lock Hvy Helical	156	532 16 60-02	Washer Srrd 5/16 ID x 1.125
16	873 80 05-00	Nut, Lock Hex w/Ins 5/16-18 UNC	158	532 16 55-89	Bracket Shift Mount
18	874 78 06-16	Bolt Hex 3/8-16 UNC x 1 Gr.5	159	532 18 39-00	Hub Tapered Flange Shift Lt
19	873 80 06-00	Nut, Lock Hex w/Wsh 3/8-16 UNC	160	819 29 20-16	Washer 29/32 x 1-1/4 x 16 Ga
21	532 10 69-33	Knob Round 1/2-13 Unc Blk	161	872 14 04-06	Bolt Rdhd Sqnk 1/4-20 x 3/4 Gr 5
22	532 17 56-07	Rod, Brake CRD Main	162	873 68 04-00	Nut Crownlock 1/4-20 Unc
24	873 35 06-00	Nut	163	874 78 04-16	Bolt Hex Fin 1/4-20 Unc x 1 Gr 5
25	532 10 68-88	Spring, Rod, Brake	164	819 09 10-10	Washer 5/8 x .281 x 10 Ga.
26	819 13 13-16	Washer 13/32 x 13/16 x 16 Ga.	165	532 16 56-23	Bracket Pivot Lever
27	876 02 04-12	Pin, Cotter 1/8 x 3/4	166	532 16 68-80	Screw 5/16-18 x 5/8
28	532 17 57-65	Rod, Parking Brake	167	532 16 55-88	Bracket Support Shift CRD
29	532 07 16-73	Cap, Parking Brake	168	532 16 54-92	Bolt Shoulder 5/16-18 x .561
30	532 17 49-73	Bracket, Mfg. Transaxle	171	817 49 06-08	Screw Thdrol 3/8-16 x 1/2 Ty-Tt
34	532 17 55-78	Shaft, Asm Pedal Foot CRD	172	532 16 56-35	Shaft Asm Shift Front CRD PMST
35	532 12 01-83	Bearing, Nylon	177	532 16 59-32	Keeper Flat Idler 3.06" CRD
36	819 21 16-16	Washer 21/32 x 1 x 16 Ga.	178	532 16 59-33	Keeper Belt Idler 1.88" CRD
37	532 12 49-63	Pin, Roll 3/16 x 1"	179	532 12 09-58	Washer Sintered
38	532 16 59-36	Pulley, Flat	180	532 16 56-30	Pulley Flat Composite 3.06"
39	874 76 06-44	Bolt Fin Hex 3/8-16 Unc x 2-3/4	181	532 18 02-11	Bracket Idler Ground Drive CRD
40	532 12 49-65	Spacer, Split 395 x 59 Bzp	182	532 18 26-82	Keeper Belt 2.5" Od V-Idler CRD
42	819 13 13-12	Washer 13/32 x 13/16 x 12 Ga.	183	532 17 90-50	Pulley V-Idler 2.50" Od CRD
43	819 11 10-12	Washer 11/32 x 5/8 x 12 Ga.	184	817 49 06-44	Screw Hexwsh Thdrol 3/8-16 x 2-3/4
47	532 12 77-83	Pulley, Idler, V Groove Plasic	187	817 58 05-20	Screw 5/16-18 x 1.25
48	532 15 44-07	Bellcrank Clutch Grnd Drv	203	871 17 07-80	Bolt Hex 7/16-20 x 5
49	532 12 32-05	Retainer, Belt Style Spring	214	532 17 56-09	Shaft Asm. Brake
50	872 11 06-12	Bolt Carr SH 3/8-16 x 1-1/2 Gr. 5	215	532 17 56-51	Rod Brake Secondary
51	873 68 06-00	Nut, Crownlock 3/8-16 UNC	250	817 06 06-12	Screw 3/8-16 x .75
53	532 10 57-10	Link, Clutch 7.66	253	532 17 50-28	Bracket Cable Chassis
55	532 10 57-09	Spring, Return, Clutch	254	817 00 06-16	Screw 3/8-16 x 1.0
56	874 76 06-20	Bolt, Hex 3/8-16 UNC x 1-1/4	255	532 17 56-08	Brace Shaft Brake
57	532 16 56-31	V-Belt Kev PMST CRD	258	532 17 80-62	Clip Retainer
62	532 12 48-72	Cover, Pedal	261	532 13 14-94	Pulley Idler Flat
65	810 04 07-00	Washer	263	817 00 06-12	Screw Hxwsh Thdr 3/8-16 x 3/4
66	532 15 47-78	Keeper, Belt Engine F-Proof	264	532 18 19-95	Bracket Clutch Mtg.
74	532 13 70-57	Spacer Axle	265	532 18 20-13	Spacer Idler Chassis
75	532 12 17-49	Washer 25/32 x 1-1/4 x 16 Ga.	266	532 18 20-61	Shield Idler
76	812 00 00-01	Ring, E	267	872 14 06-26	Bolt Rdhd Sqnk 3/8-16 x 3-1/4
77	532 12 35-83	Key, Square	269	532 18 24-02	Guard Muffler OHV B&S RH
78	532 12 17-48	Washer 25/32 x 1-5/8 x 16 Ga.			

NOTE: All component dimensions given in U.S. inches
1 inch = 25.4 mm

REPAIR PARTS

TRACTOR - - MODEL NO. BL13536RB (BL13592RBA), PRODUCT NO. 964 79 15-00
STEERING ASSEMBLY

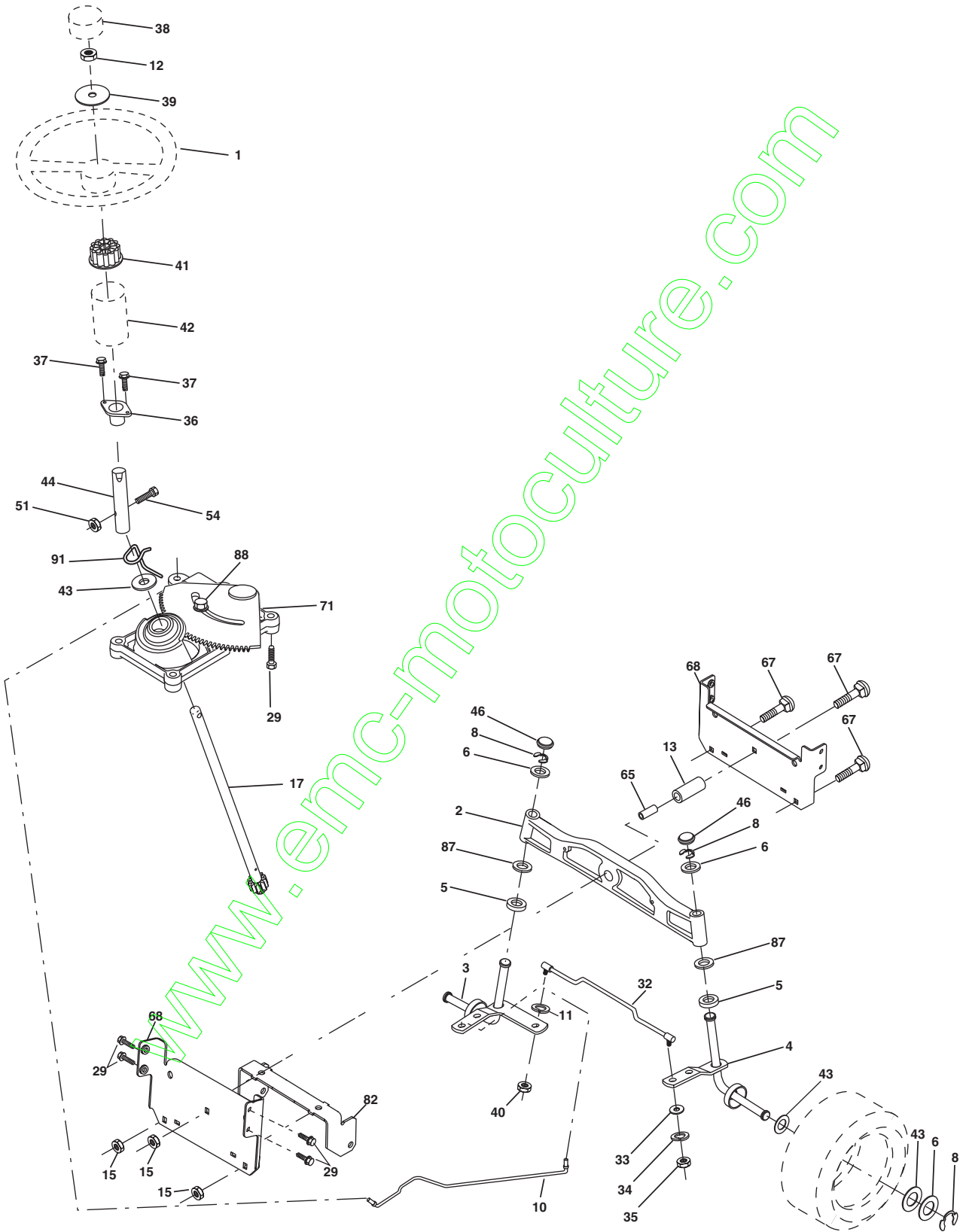

REPAIR PARTS

TRACTOR - - MODEL NO. BL13536RB (BL13592RBA), PRODUCT NO. 964 79 15-00
STEERING ASSEMBLY

KEY NO.	PART NO.	DESCRIPTION
1	532 13 97-68	Steering Wheel
2	532 17 23-93	Cast Iron Axle Assembly
3	532 16 98-40	Spindle Assembly, L.H.
4	532 16 98-39	Spindle Assembly, R.H.
5	532 12 49-31	Bearing, Race, Thrust, Hardened
6	532 12 17-48	Washer 25/32 x 1-5/8 x 16 Gauge
8	812 00 00-29	Ring, Klip
10	532 17 51-21	Link, Drag
11	810 04 06-00	Washer, Lock
12	873 94 08-00	Nut Hex Jam Toplock 1/2-20 Unf
13	532 13 65-18	Spacer Brg Axle Front
15	532 14 52-12	Nut, Hexflange Lock
17	532 18 06-41	Shaft Assembly, Steering
29	817 06 06-12	Screw, 3/8-16 x 3/4
32	532 17 01-62	Rod, Tie
33	819 11 12-16	Washer 11/32 x 3/4 x 16 Ga
34	810 04 05-00	Washer Lock Hvy Hlcl Spr 5/16
35	873 54 05-00	Nut Crownlock 5/16-24 Unf
36	532 15 50-99	Bushing, Steering
37	532 15 29-27	Screw TT #10-32 x 5 x 3/8 Flange
38	532 14 01-75	Cap Wheel Steer
39	819 18 38-12	Washer 9/16 x 2-3/8
40	532 12 47-01	Nut Lock Center 3/8-24 Unf
41	532 10 07-11	Adaptor, Steering Wheel
42	532 16 96-33	Boot, Steering Dash P/L Mtl
43	532 12 17-49	Washer 25/32 x 1-1/4 x 16 Gauge
44	532 18 06-40	Extension Steering
51	873 54 04-00	Nut Crownlock 1/4-28
54	871 13 04-20	Bolt Hex 1/4-28unf x 1-1/4 Gr. 8
46	532 12 12-32	Cap, Spindle
65	532 16 03-67	Spacer Brace Axle
67	872 14 06-18	Bolt Rdhd Sq 3/8-16 UNC x 2-1/4
71	532 17 51-46	Steering Asm.
68	532 16 98-27	Brace Axle
82	532 16 98-35	Bracket Susp Chassis Front
87	532 17 39-66	Washer Flat .781 x 1-1/2 x .14
88	532 17 51-18	Bolt Shoulder 7/16-20 Unc
91	532 17 55-53	Clip Steering

NOTE: All component dimensions given in U.S. inches.
1 inch = 25.4 mm.

REPAIR PARTS

TRACTOR - - MODEL NO. BL13536RB (BL13592RBA), PRODUCT NO. 964 79 15-00
SEAT ASSEMBLY

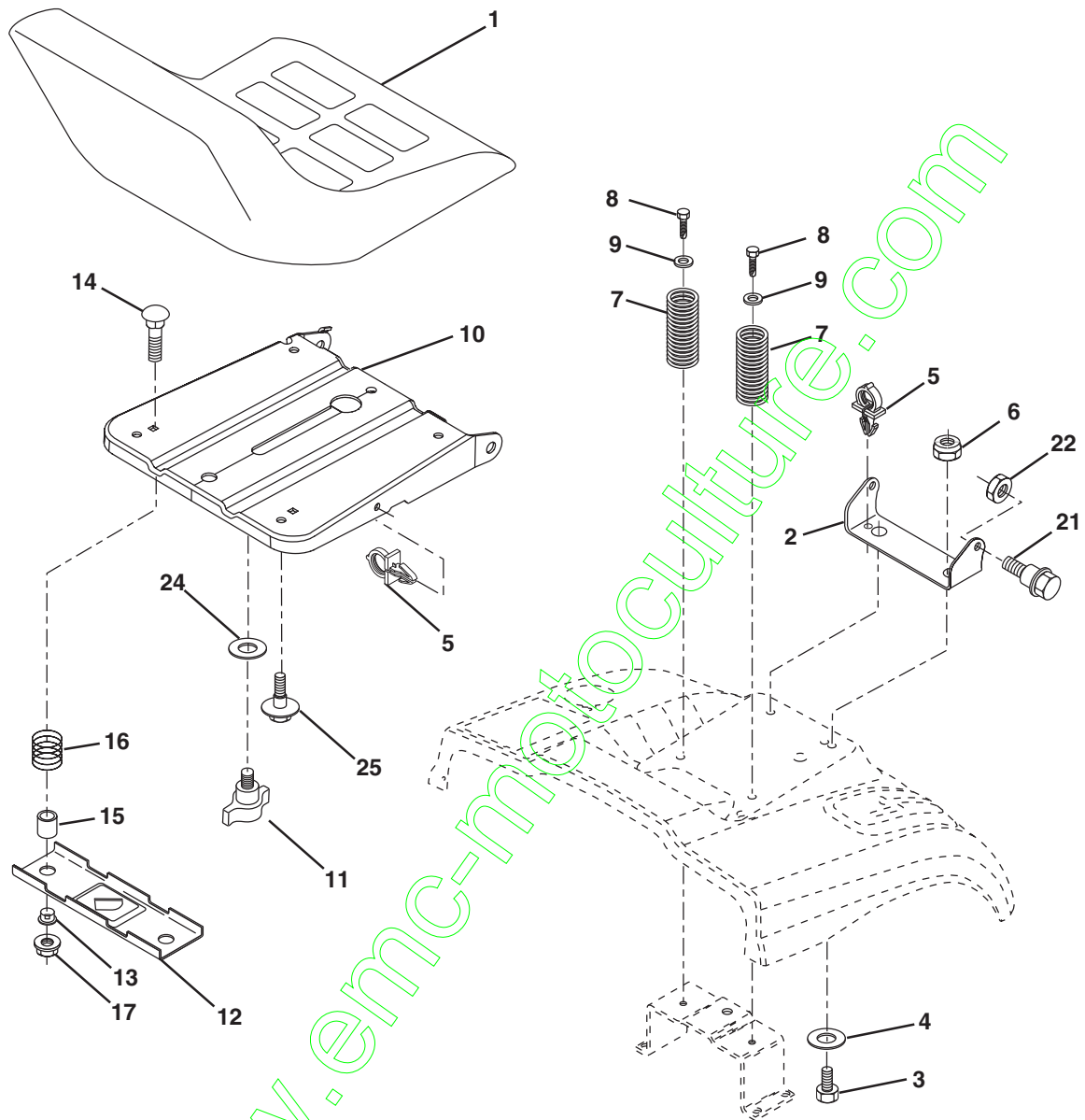

KEY NO.	PART NO.	DESCRIPTION
1	532 17 53-90	Seat
2	532 14 05-51	Bracket Pnt Pivot Seat (blk)
3	871 11 06-16	Bolt Fin Hex 3/8-16 Unc x 1
4	819 13 16-10	Washer Flat 13/32 x 1 x 10 Ga.
5	532 14 50-06	Clip Push In Hinged
6	873 80 06-00	Nut Lock Hex 3/8-16 Unc
7	532 12 41-81	Spring Seat Cprsn 2 250 Blk Zi
8	817 00 06-16	Screw 3/8-16 X 1-1/2
9	819 13 16-14	Washer 13/32 X 1 X 14 Ga
10	532 18 24-93	Pan Pnt Seat (blk)
11	532 16 63-69	Knob Seat
12	532 12 12-46	Bracket Pnt Mounting Switch

KEY NO.	PART NO.	DESCRIPTION
13	532 12 12-48	Bushing Snap Blk Nyl 50 Id
14	872 05 04-12	Bolt Rdhd Sht Nk 1/4-20x1-1/2
15	532 12 12-49	Spacer Split
16	532 12 37-40	Spring Cprsn Plate SW 1.310 Ga
17	532 12 39-76	Nut Lock 1/4 Lge Flg Gr 5 Zinc
21	532 17 18-52	Bolt Shoulder 5/16-18 Unc-2A
22	873 80 05-00	Nut Hex Lock w/Ins 5/16-18
24	819 17 19-12	Washer 17/32 X 1-3/16 X 12 Ga.
25	532 12 70-18	Bolt Shoulder 5/16-18 X 62

NOTE: All component dimensions given in U.S. inches.
1 inch = 25.4 mm

REPAIR PARTS

TRACTOR - - MODEL NO. BL13536RB (BL13592RBA), PRODUCT NO. 964 79 15-00
DECALS

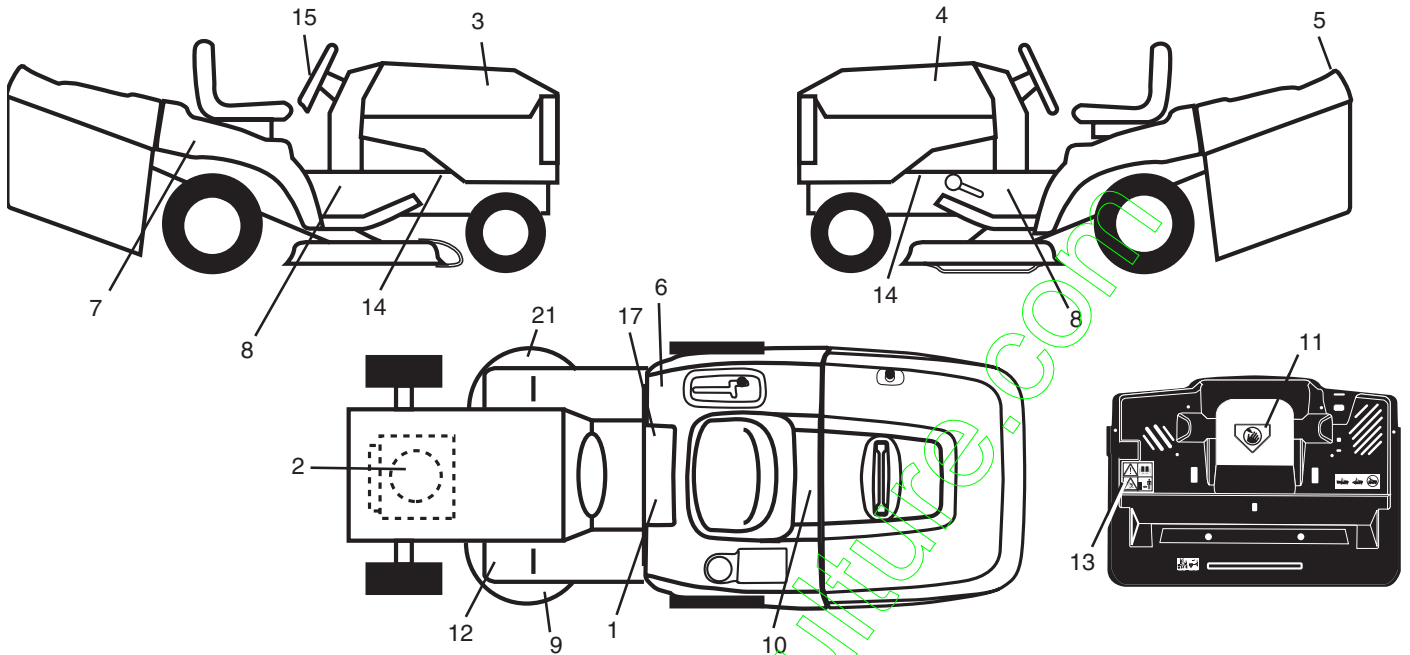

KEY NO.	PART NO.	DESCRIPTION	KEY NO.	PART NO.	DESCRIPTION
1	532 14 54-98	Decal Read Owner's Manual Sym	12	532 15 97-37	Decal Brake/Clutch Symbol Lt
2	532 18 48-44	Decal Hp Engine	13	532 18 04-35	Decal Warn Back Plate CRD
3	532 18 56-63	Decal Hood RH	14	532 15 97-36	Decal Chassis Hot Muffler
4	532 18 56-64	Decal Hood LH	15	532 18 56-67	Decal Steering Wheel
5	532 18 26-21	Decal Bagger	17	532 14 08-37	Decal Saddle Brake Parking
6	532 18 04-32	Decal 100 DBA/CE	21	532 16 62-86	Decal Hex Belt Sch 92 CRD
7	532 18 56-66	Decal Fender Log	—	532 13 83-11	Decal Lift Handle
8	532 18 56-69	Decal Chassis HP	—	532 18 10-91	Pad Footrest LH
9	532 13 49-99	Decal Mower Enviro	—	532 18 10-90	Pad Footrest RH
10	532 14 50-05	Decal Bat Dan/Poi P/L Sym Wpr	—	532 18 52-30	Manual Operator's (Euro)
11	532 18 21-66	Decal Mower Cut Finger CE			

WHEELS & TIRES

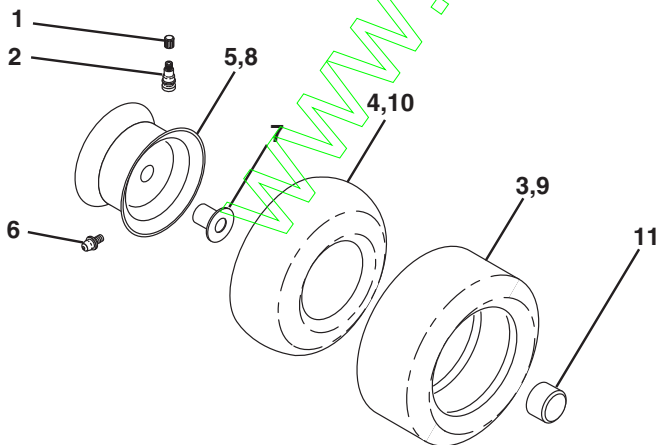

KEY NO.	PART NO.	DESCRIPTION
1	532 05 91-92	Cap Value Tire
2	532 06 51-39	Stem Value
3	532 10 62-22	Tire F Ts 15 X 6 0 - 6 Service
4	532 05 99-04	Tube Inner Front #35060
5	532 12 51-21	Rim Asm 6"front Service
6	532 12 49-57	Fitting Grease
7	532 12 49-59	Bearing Flange
8	532 12 51-22	Rim Asm 8"rear Service
9	532 12 46-35	Tire R Ts 20 x 8-8 Service
10	532 12 49-26	Tube Rear 9 5 X 8 Service
11	532 17 50-39	Cap Axle Blk 1 50 X 1 00
--	532 14 43-34	Sealant, Tire (10 oz. tube)

NOTE: All component dimensions given in U.S. inches
1 inch = 25.4 mm

REPAIR PARTS

TRACTOR - - MODEL NO. BL13536RB (BL13592RBA), PRODUCT NO. 964 79 15-00
ENGINE

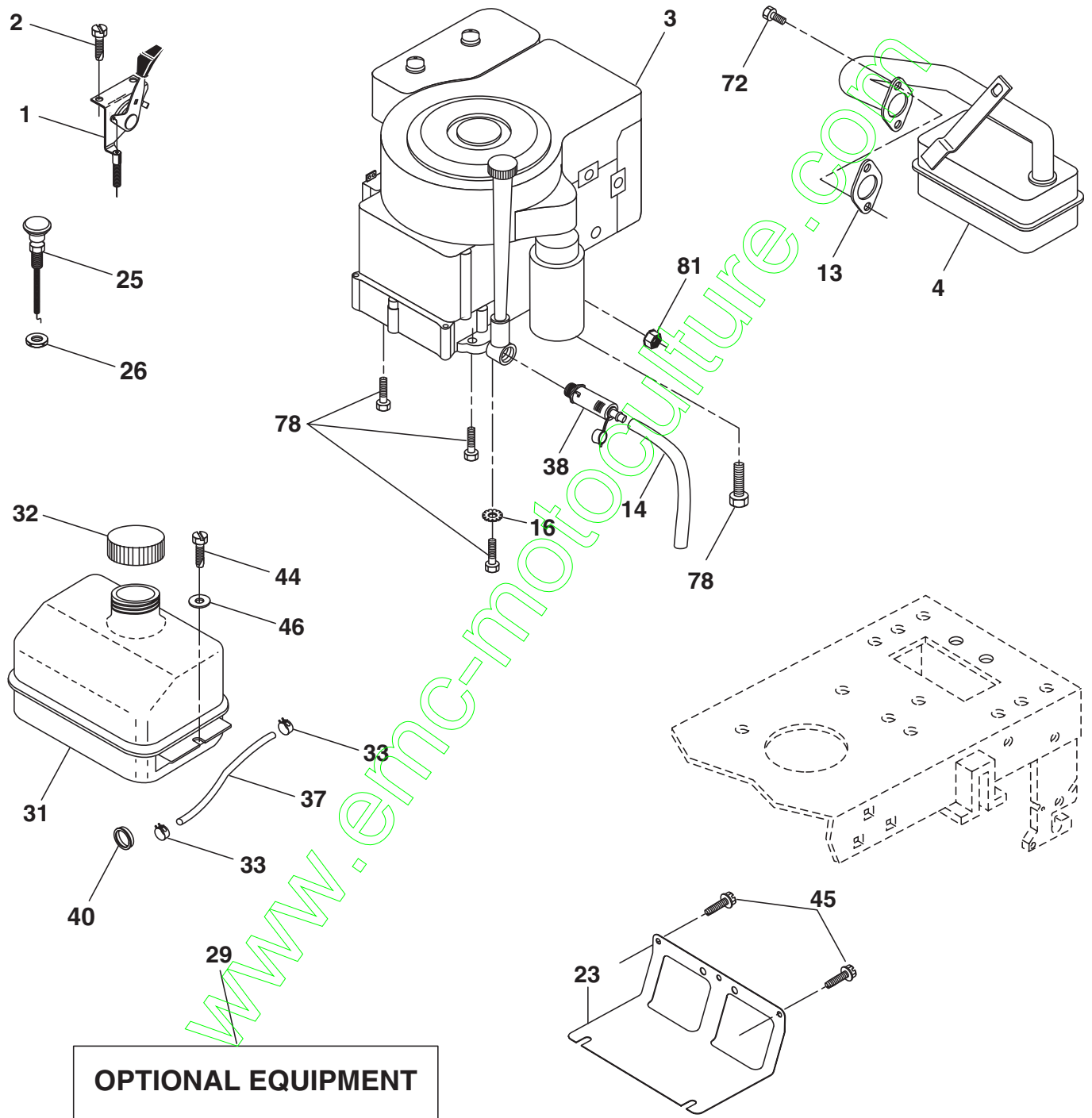

REPAIR PARTS

TRACTOR - - MODEL NO. BL13536RB (BL13592RBA), PRODUCT NO. 964 79 15-00
ENGINE

KEY NO.	PART NO.	DESCRIPTION
1	532 17 05-51	Control Throt /Ch
2	817 72 04-08	Screw Hex Thd Cut 1/4-20x5/8 T
3	-----	Engine B&S Model 282H07 (Order Parts from Engine Manufacturer)
4	532 13 73-52	Muffler Exhaust B&S Lt
13	532 16 52-91	Gasket 1 313 Id Tin Plated
14	532 14 84-56	Tube Drain Oil Easy
16	811 05 06-00	Washer Lock Ext Tooth 3/8
23	532 16 98-37	Shield Browning/Debris Guard
25	532 18 09-45	Control Choke 1 Cyl.
26	873 92 06-00	Nut Keps 3/8-24 Unf.
29	532 13 71-80	Arrestor Spark
31	532 18 49-00	Tank Fuel
32	532 14 05-27	Cap Asm Fule Top Vent N/Lany
33	532 12 34-87	Clamp Hose Blk
37	532 13 70-40	Line Fuel 20"
38	532 18 16-54	Plug Drain Oil Easy
40	532 12 40-28	Bushing Snap
44	817 67 04-12	Screw Hexwsh Thdrol 3/8-16 x 3/4
45	817 00 06-12	Screw 3/8-16 x 3/4
46	819 09 14-16	Washer 9/32 X 7/8 X 16 Ga.
72	532 18 39-06	Screw Socket Head 5/16-18 x 1
78	817 06 06-20	Screw 3/8-16x1-1/4
81	873 51 04-00	Nut Keps Hex 1/4-20 UNC

NOTE: All component dimensions given in U.S. inches
1 inch = 25.4 mm

REPAIR PARTS

TRACTOR - - MODEL NO. BL13536RB (BL13592RBA), PRODUCT NO. 964 79 15-00
MOWER LIFT

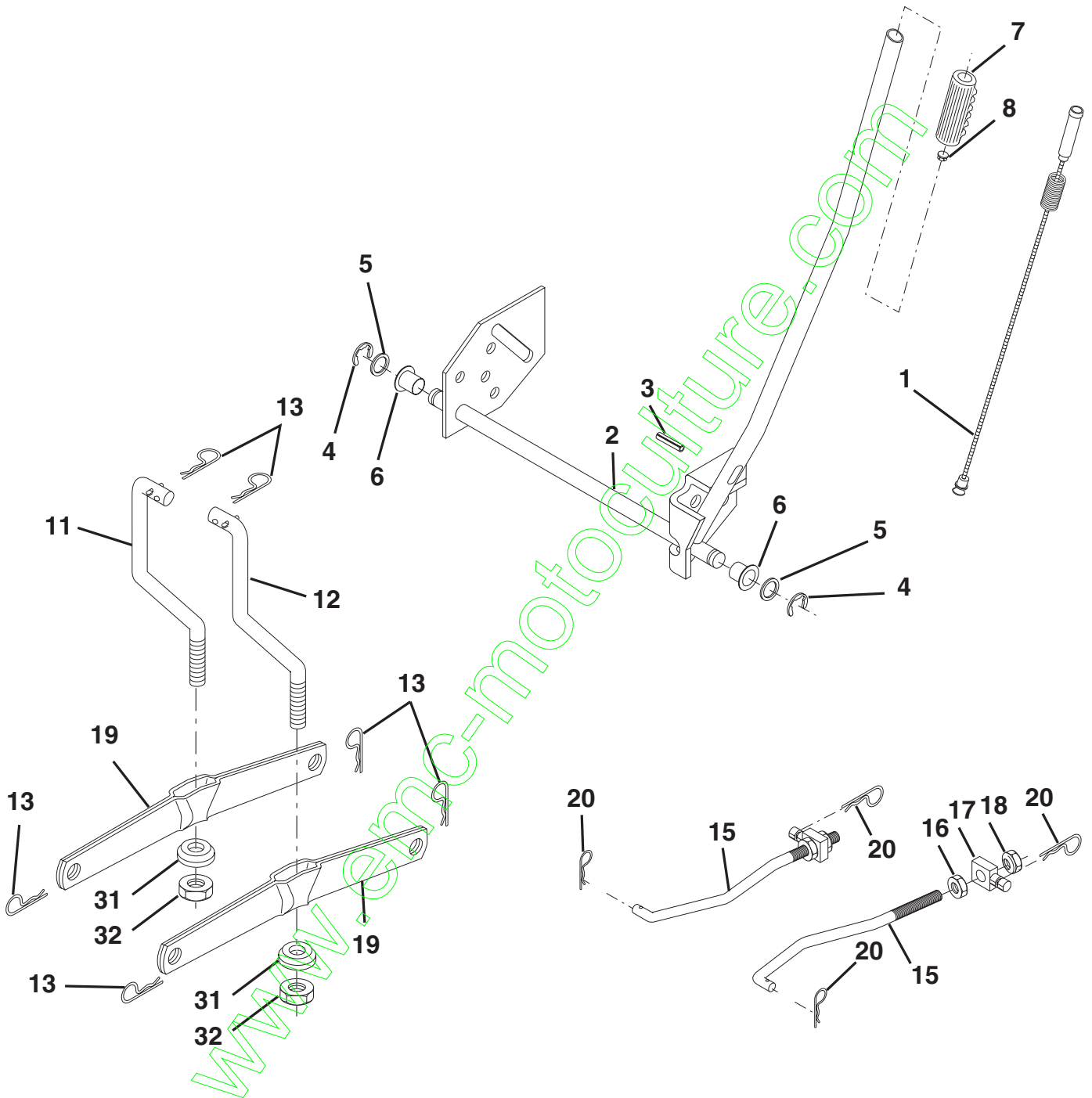

REPAIR PARTS

TRACTOR - - MODEL NO. BL13536RB (BL13592RBA), PRODUCT NO. 964 79 15-00
MOWER LIFT

KEY NO.	PART NO.	DESCRIPTION
1	532 15 94-60	Washer Asm Inner Spring W/ Plunger
2	532 15 94-71	Shaft Asm. Lift
3	532 10 57-67	Pin Groove
4	812 00 00-02	E Ring #5133-62
5	819 21 16-21	Washer 21/32 x 1 x 21 Ga.
6	532 12 01-83	Bearing Nylon
7	532 10 94-13	Grip Handle Bicycle
8	532 12 45-26	Button Plunger Black
11	532 16 58-29	Link Asm Lift L.H.
12	532 16 58-31	Link Asm Lift R.H.
13	532 12 46-70	Retainer Spring
15	532 17 32-88	Link Front
16	873 35 08-00	Nut Jam Hex 1/2-13 Unc
17	532 17 56-89	Trunnion Blk Zinc
18	873 80 08-00	Nut Lock w/Wsh 1/2-13 Unc
19	532 13 98-68	Arm Suspension Mower
20	532 16 35-52	Retainer Spring
31	532 16 98-65	Bearing, Pvt. Lift.
32	873 54 06-00	Nut Crownlock 3/8-24

NOTE: All component dimensions given in U.S. inches
1 inch = 25.4 mm

REPAIR PARTS

TRACTOR - - MODEL NO. BL13536RB (BL13592RBA), PRODUCT NO. 964 79 15-00
MOWER

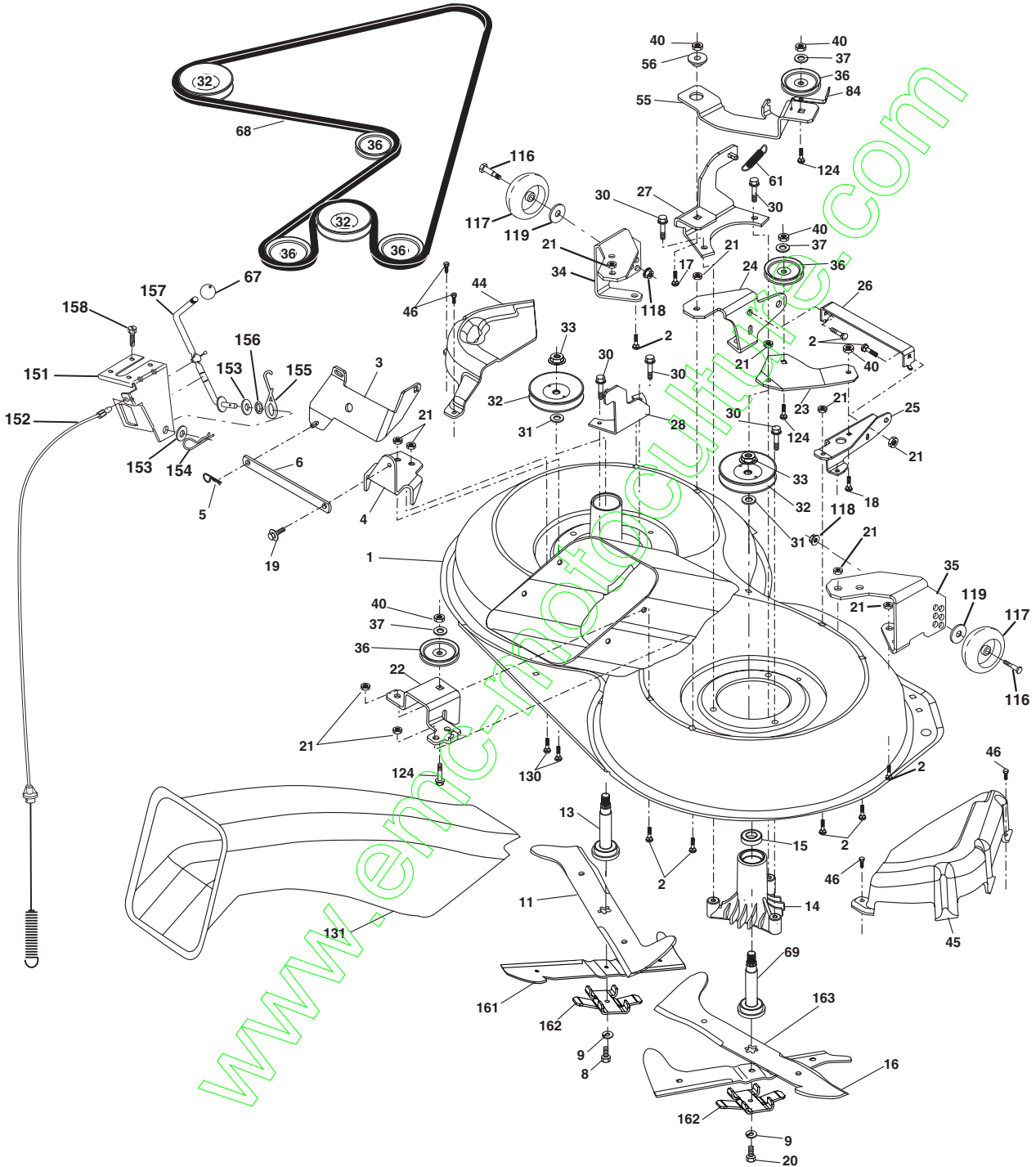

REPAIR PARTS

TRACTOR - - MODEL NO. BL13536RB (BL13592RBA), PRODUCT NO. 964 79 15-00
MOWER

KEY NO.	PART NO.	DESCRIPTION	KEY NO.	PART NO.	DESCRIPTION
1	532 16 55-52	Housing Asm. Mower	45	532 17 55-39	Cover Mandrel Rh
2	872 14 05-06	Bolt Rdhd Sqnk 5/16-18 Unc x 3/4	46	532 13 77-29	Screw Thd Roll 1/4-20 x 5/8
3	532 16 55-69	Bracket Asm. S-Bar Chass	55	532 16 54-45	Arm Idler
4	532 16 55-58	Bracket Bar Sway Deck	56	532 16 57-23	Spacer Retainer PM Mower
5	532 12 46-70	Retainer Spring	61	532 16 59-45	Spring Tension Belt
6	532 16 55-57	Bar Sway	67	532 10 69-32	Knob Rd 3/8-16 Plstc Thds Blk
8	532 18 17-12	Bolt 3/8-24 x 1.25 Gr8 Patched	68	532 18 02-17	Hex-Belt 92 Mower
9	810 03 06-00	Washer Lock Hvy 3/8 Unplated	69	532 16 54-82	Shaft Asm W/Lwr Brg Rh Thd CRD
11	532 17 00-37	Blade 3-1 Lh	84	532 15 60-85	Keeper Belt Idler
13	532 13 76-45	Shaft Asm. W/Lower Bearing	116	532 18 42-19	Bolt Shoulder
14	532 12 87-74	Housing Mandrel Vented (Machd)	117	532 13 39-57	Wheel Gage Donut Wide
15	532 11 04-85	Bearing Ball Mandrel	118	873 93 06-00	Nut Centerlock 3/8-16 Unc
16	532 17 00-38	Blade 3-1 Rh	119	819 12 14-14	Washer 3/8 x 7/8 x 14 Ga.
17	872 14 06-10	Bolt Carriage 3/8-16 x 1-1/4	124	872 11 06-12	Bolt Carr Sh 3/8-16 x 1-1/2 Gr5
18	872 11 06-06	Bolt Rdhd Sqnk 3/8-16 x 3/4	130	872 11 05-06	Bolt Rdhdsqnk 5/16-18 Unc x 3/4
19	532 13 28-27	Bolt Shoulder 5/16-18 Thd Form	131	532 16 56-61	Chute Bagger CRD
20	532 18 17-13	Bolt 3/8-24 x 1.25 Gr8 Ptch Lhthd	151	532 16 96-70	Bracket Clutch Cable
21	873 68 05-00	Nut Crown Lock 5/16-18	152	532 17 60-74	Cable Clutch CRD Service
22	532 16 52-43	Bracket Idler Sprt RR	153	532 16 96-74	Washer Flat 3/8" Type B
23	532 16 54-46	Bracket Idler Sprt RF	154	532 16 96-75	Spring Retainer
24	532 16 52-42	Bracket Suspension LF	155	532 16 96-71	Spring Retainer Lvr Cltch Cab
25	532 16 52-44	Bracket Suspension RF	156	532 16 96-72	Spacer Clutch Cable
26	532 16 52-37	Brace Support Susp Frt CRD	157	532 16 96-69	Rod Clutch Cable 3/8"
27	532 16 55-68	Bracket Asm. Susp RR	158	817 72 04-08	Screw Hex Thdcut 1/4-20 x 5/8
28	532 16 55-67	Bracket Asm. Susp LR	161	532 18 04-18	Blade Cross Lh 92
30	532 17 39-84	Screw Thd Rolling Washer Head	162	532 18 60-13	Adapter Blade Cross
31	532 12 99-63	Washer Spacer Mower Vented	163	532 18 04-19	Blade Cross Rh 92
32	532 15 35-31	Mandrel Pulleys 36 & 46	--	532 18 18-57	Mandrel Asm Service
33	532 17 83-42	Nut Flg Top Lock	--	532 18 18-58	Mandrel Asm CRD Lh Threads SVC
34	532 16 52-39	Bracket Gauge Wheel Lf	--	532 18 17-65	Replacement Mower Complete
35	532 16 52-38	Bracket Gauge Wheel Rf			
36	532 14 67-63	Pulley Idler V-Groove Dim 4.25			
37	819 13 13-16	Washer 11/32 x 13/16 x 16 Ga			
40	873 68 06-00	Nut Crownlock 3/8-16 Unc			
44	532 17 55-38	Cover Mandrel Lh			

NOTE: All component dimensions given in U.S. inches
1 inch = 25.4 mm

REPAIR PARTS

TRACTOR - - MODEL NO. BL13536RB (BL13592RBA), PRODUCT NO. 964 79 15-00
BAGGER

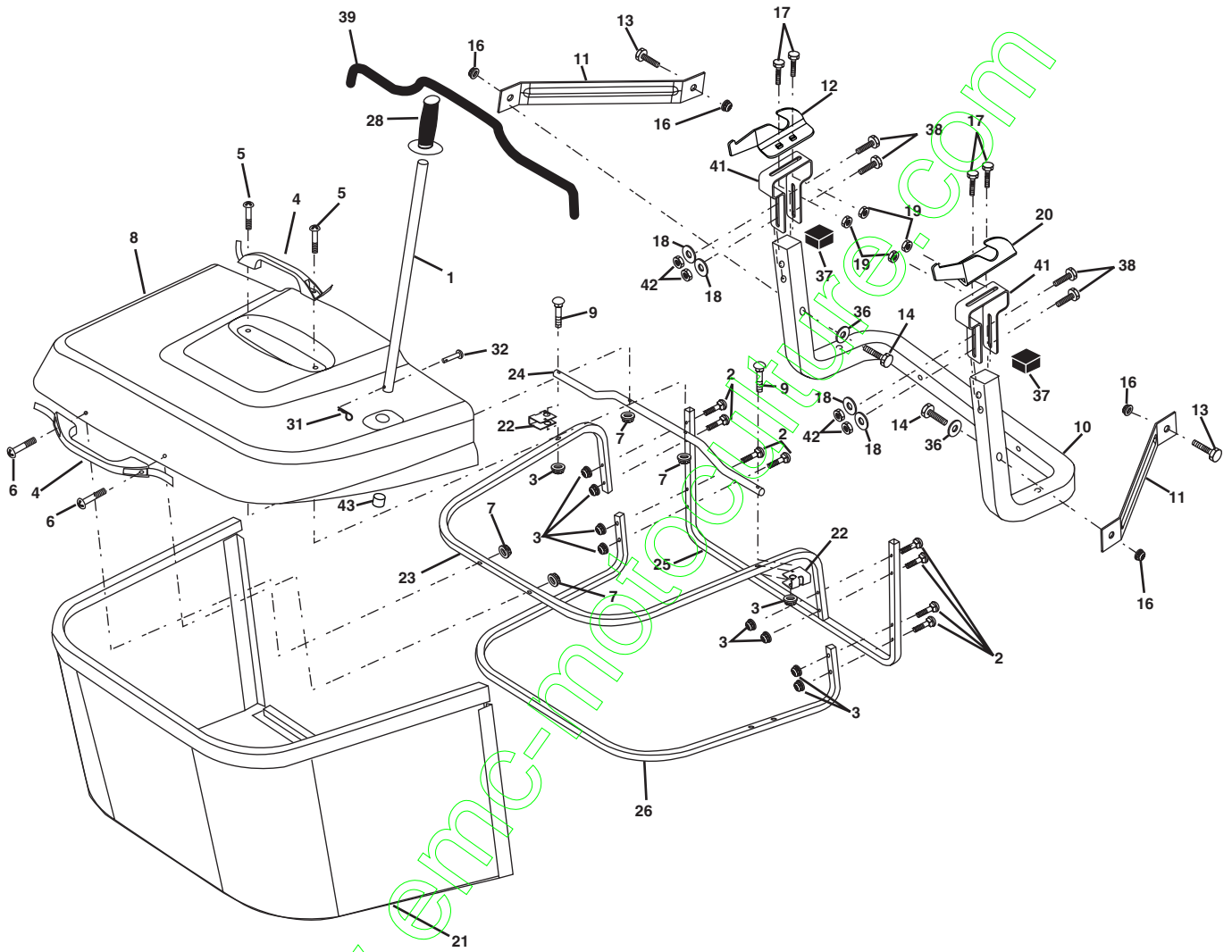

REPAIR PARTS

TRACTOR - - MODEL NO. BL13536RB (BL13592RBA), PRODUCT NO. 964 79 15-00
BAGGER

KEY NO.	PART NO.	DESCRIPTION
1	532 16 52-49	Tube Handle Bagger CRD
2	872 14 04-16	Bolt Carriage 1/4-20 X 2.0 Gr.5
3	532 12 39-76	Nut Lock 1/4 Lge Flg Gr. 5 Zinc
4	532 16 99-16	Handle Bagger w/Lvrs Gr. 5 Zinc
5	874 98 10-24	Screw Pan Head #10-24 X 1.50 Bk
6	874 98 10-32	Screw Pan Hd
7	873 40 10-00	Nut Wiz Lock Hex Serr/Hd #10-24
8	532 18 13-87	Cover Bagger Steel
9	872 14 04-18	Bolt Carriage 1/4-20 x 2.25d x Gr.5
10	532 18 12-82	Tube Support Bagger CRD
11	532 16 57-19	Bracket Support Upper Bag CRD
12	532 16 96-85	Bracket Horiz Adj Bagger
13	872 11 06-06	Bolt Rdhd Sht Sqnk 3/8-16 X 3/4
14	874 52 06-36	Bolt Fin Hex 3/8-16 X 2-1/4 Gr. 5
16	873 90 06-00	Nut Lock Flg 3/8-16 Unc
17	872 14 05-06	Bolt Rdhd Sht Sqnk 5/16-18Unc X 3/4
18	819 11 12-16	Washer 11/32 x 3/4 x 16 Ga.
19	873 90 05-00	Nut Lock Hex Flange 5/16-18
20	532 16 96-84	Bracket Horiz Adj Bagger
21	532 18 08-80	Bag Asm CRD
22	532 16 57-81	Bracket Side Bagger CRD
23	532 16 57-82	Tube Upper Bagger CRD
24	532 16 57-83	Tube Pivot Bagger CRD
25	532 18 01-24	Tube Front Bagger CRD
26	532 16 57-85	Tube Lower Bagger CRD
28	532 16 57-87	Grip Handle Black
31	532 12 47-88	Retainer Spring 1" Zinc/Cad
32	532 12 68-75	Rivet Rd Hd Drilled 3/8 Dia
36	819 13 20-16	Washer 13/32 x 1-1/4 x 16 Ga.
37	532 17 54-01	Plug Support Bagger CRD
38	872 01 05-20	Bolt 5/16-18 x 2-1/2
39	532 18 09-85	Seal Trim 37"
41	532 16 96-83	Bracket Vert Adj Bagger CRD
42	873 80 05-00	Nut Lock Hx w/Ins 5/16-18 Unc
43	532 17 40-83	Plug Tubing End

NOTE: All component dimensions given in U.S. inches
1 inch = 25.4 mm

TRACTOR - - MODEL NO. BL13536RB (BL13592RBA), PRODUCT NO. 964 79 15-00 SCHEMATIC

