

ILLUSTRATED PARTS BREAKDOWN

BERNARD

13.5 HP LAWN TRACTOR

MODEL NO. BL13542SBK (BL135107A)

964 77 14-00

www.emc-motoculture.com

REPAIR PARTS

TRACTOR - MODEL NO. BL13542SBK (BL135107A), PRODUCT NO. 964 77 14-00

ELECTRICAL

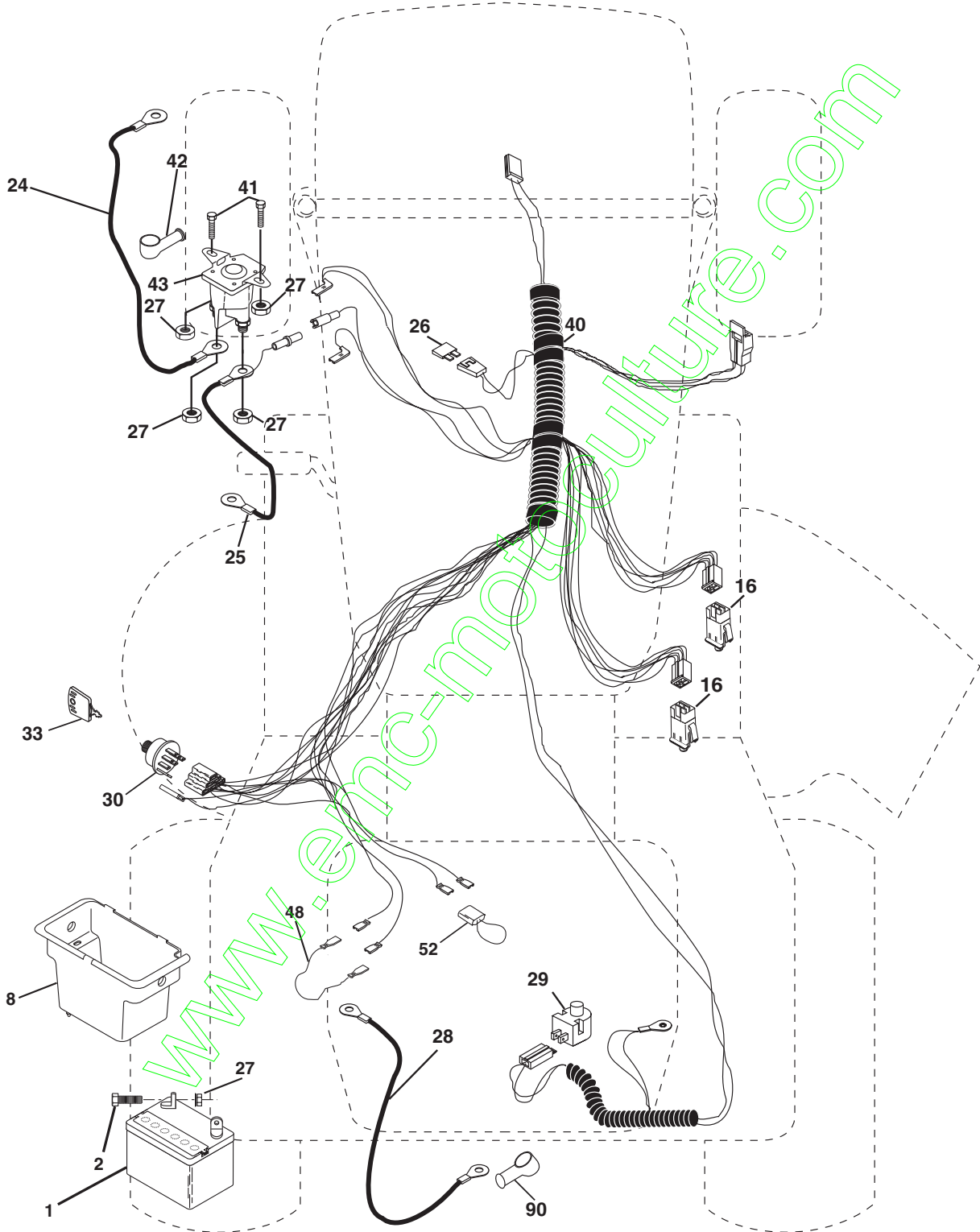

REPAIR PARTS

TRACTOR - MODEL NO. BL13542SBK (BL135107A), PRODUCT NO. 964 77 14-00

ELECTRICAL

KEY NO.	PART NO.	DESCRIPTION
1	532 16 34-65	Battery 12 Volt 28 AMP
2	874 76 04-12	Bolt Hex Hd 1/4-20unc X 3/4
8	532 17 66-89	Box Battery Fender
16	532 17 61-38	Switch Interlock Push-In
24	532 12 47-80	Cable Battery 6 Ga 11" red
25	532 14 61-47	Cable Battery 6 Ga 44" red w/16 wire
26	532 17 51-58	Fuse 20 AMP
27	873 51 04-00	Nut Keps Hex 1/4-20 Unc
28	532 12 47-73	Cable Ground 6 Ga 12" black
29	532 12 13-05	Switch Plunger Nc Gray
30	532 17 55-67	Switch Ign
33	532 14 04-01	Key Ign
40	532 17 97-30	Harness Ign.
41	871 11 04-08	Bolt Blk Fin Hex 1/4 - 20 x 1/2
42	532 13 15-63	Cover Terminal Red
43	532 17 88-61	Solenoid
48	532 14 08-44	Adapter Ammeter
52	532 14 19-40	Protection Wire Loop
90	532 18 04-49	Cover Terminal Battery

NOTE: All component dimensions given in U.S. inches.
1 inch = 25.4 mm.

REPAIR PARTS

TRACTOR - MODEL NO. BL13542SBK (BL135107A), PRODUCT NO. 964 77 14-00

CHASSIS AND ENCLOSURES

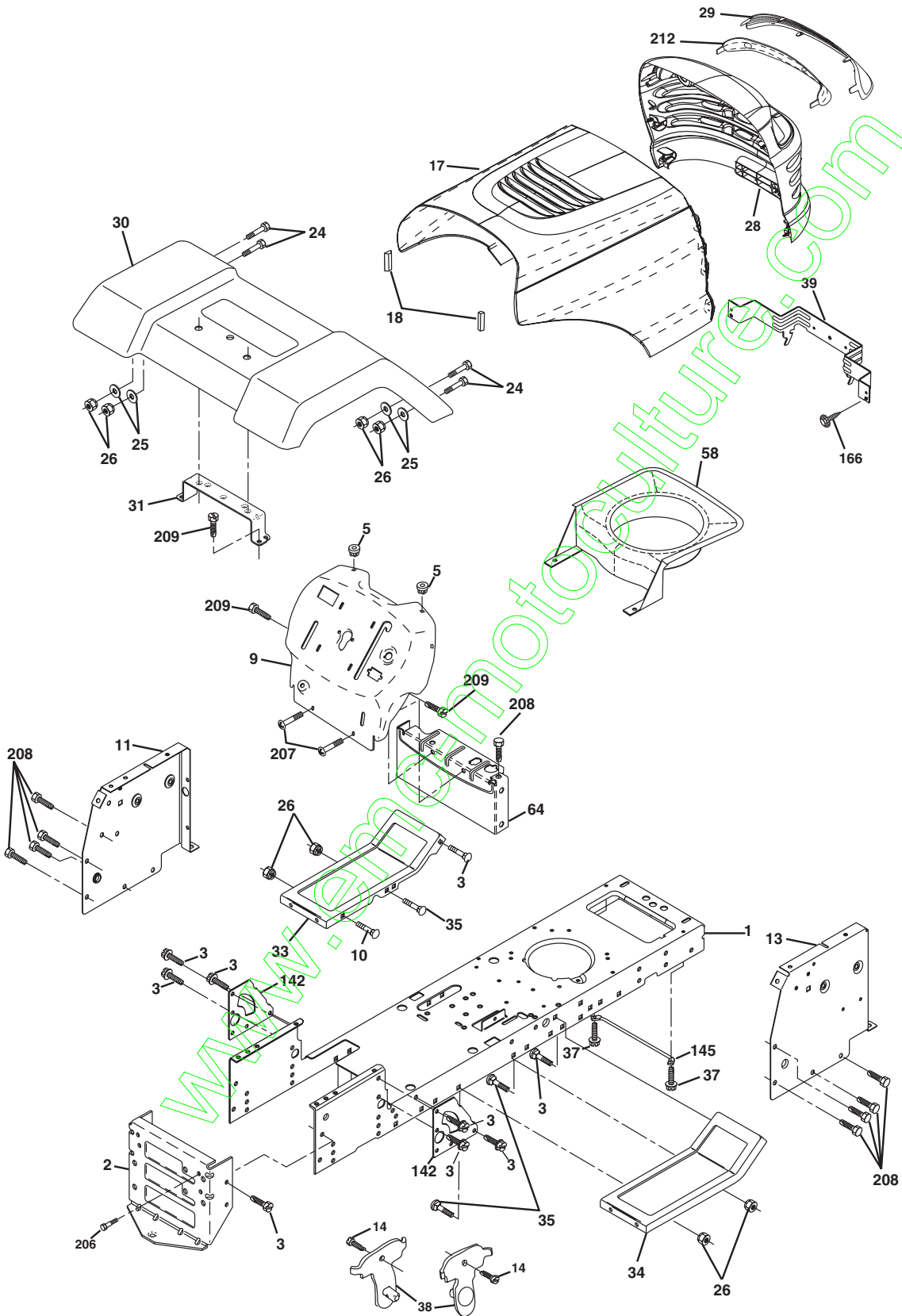

REPAIR PARTS

TRACTOR - MODEL NO. BL13542SBK (BL135107A), PRODUCT NO. 964 77 14-00
CHASSIS AND ENCLOSURES

KEY NO.	PART NO.	DESCRIPTION
1	532 17 46-19	Chassis Weldment
2	532 17 65-54	Drawbar
3	817 06 06-12	Screw 3/8-16 x .75 SMGML
5	532 15 52-72	Bumper Hood/Dash
9	532 18 52-74	Dash P/L
10	872 14 06-08	Bolt Carriage 3/8-16 x 1
11	532 17 49-96	Panel Dash Lh
13	532 18 17-19	Panel Dash Rh
14	817 49 06-08	Screw Thdrol 3/8-16 x 1/2
17	532 18 29-07	Hood Laser LT
18	532 18 49-21	Bumper Hood
24	874 78 06-16	Bolt Fin Hex 3/8-16 UNC x 1 Gr5
25	819 13 13-12	Washer 13/32 X 13/16 X 12 Ga
26	873 80 06-00	Nut Lock Hex W/Ins 3/8-16 Unc
28	532 17 97-50	Grill/Lens Asm.
29	532 18 37-60	Lens Grille Laser
30	532 17 30-26	Fender
31	532 13 66-19	Bracket Support Fender
33	532 18 10-57	Footrest LH
34	532 18 10-58	Footrest RH
35	872 11 06-06	Bolt RDHD 3/8-16 x 3/4
37	817 49 05-08	Screw Thdrol 6/16-18 x 1/2 TYT
38	532 17 57-10	Bracket, Asm. Pivot
39	532 17 47-14	Bracket Pivot Laser
58	532 15 01-27	Duct Air Engine
64	532 15 47-98	Dash Lower STLT
142	532 17 57-02	Plate Reinforcement STLT
145	532 15 65-24	Rod Pivot Chassis/Hood
166	532 17 18-75	Screw HWHD Li-Lo #13-16 x 3/4
206	532 17 01-65	Bolt Shoulder 5/16-18
207	817 67 05-08	Screw Thdrol 5/16-18 x 1/2
208	817 67 06-08	Screw Thdrol 3/8-16 x 1/2
209	817 00 06-12	Screw Hexwsh THDR 3/8-16 x 3/4
212	532 17 51-43	Insert Lens Reflective

NOTE: All component dimensions given in U.S. inches
1 inch = 25.4 mm

REPAIR PARTS

TRACTOR - MODEL NO. BL13542SBK (BL135107A), PRODUCT NO. 964 77 14-00

DRIVE

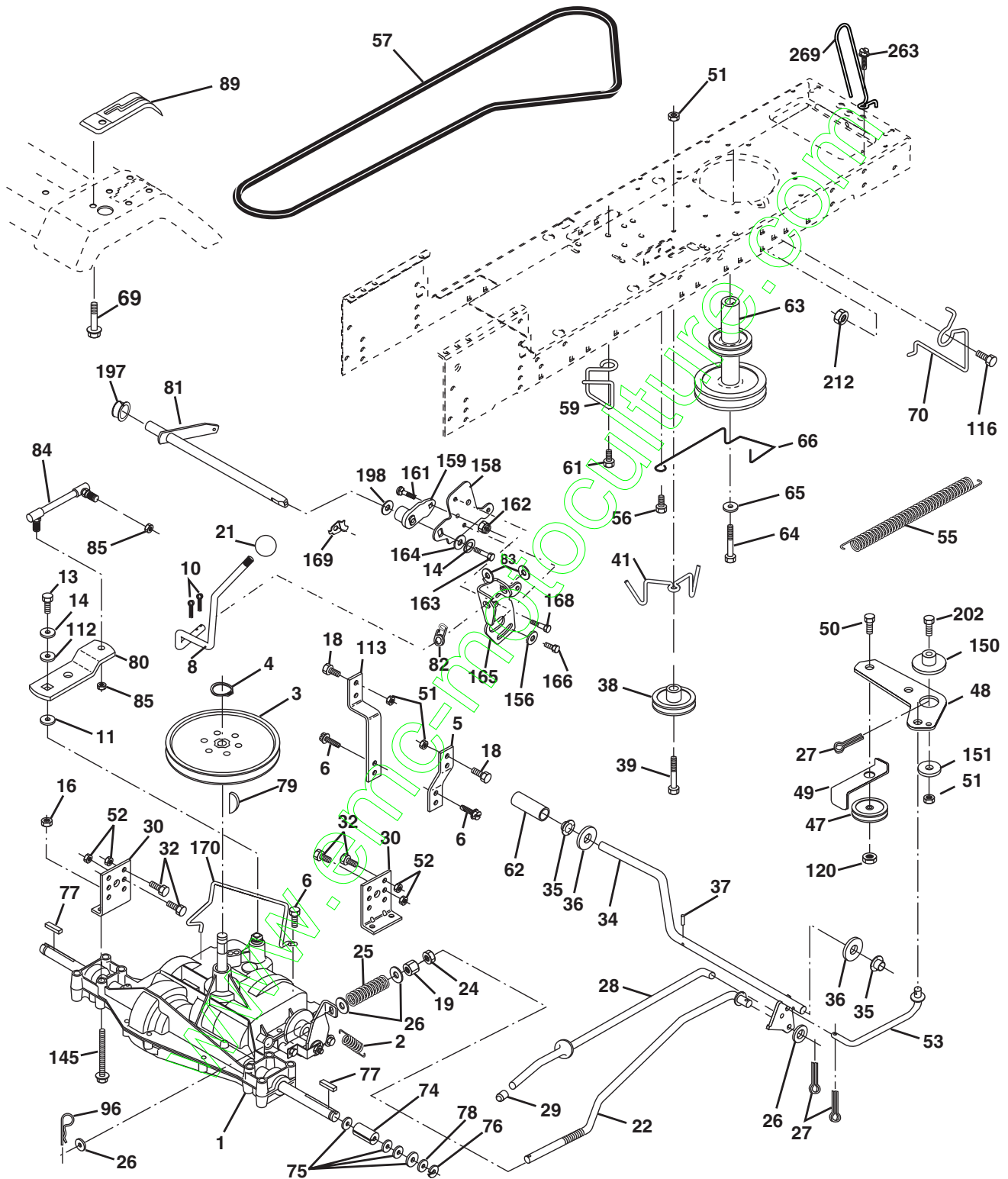

REPAIR PARTS

TRACTOR - MODEL NO. BL13542SBK (BL135107A), PRODUCT NO. 964 77 14-00

DRIVE

KEY NO.	PART NO.	DESCRIPTION	KEY NO.	PART NO.	DESCRIPTION
1	-----	Transaxle Peerless 206-545C Order parts from transaxle manufacturer	64	871 17 07-64	Bolt Hex
2	532 14 66-82	Spring Return Brake T/a Zinc	65	810 04 07-00	Washer Lock Hvy Hlcl Spr 7/16
3	532 12 36-66	Pulley Transaxle 18" tires	66	532 15 47-78	Keeper Belt Engine Foolproof
4	812 00 00-28	Ring Retainer # 5100-62	69	532 14 24-32	Screw Hex 1/4-1/2 UNC
5	532 12 15-20	Strap Torque 30 Degrees	70	532 18 02-18	Guide Belt Mower Drive RH
6	817 06 05-12	Screw Thdrol 5/16-18	74	532 13 70-57	Spacer Axle
8	532 16 56-19	Rod Shift Fender Adjust Lt	75	532 12 17-49	Washer 25/32 X 1 1/4 X 16 Ga
10	876 02 04-16	Pin Cotter 1/8 X 1 Cad	76	812 00 00-01	E-ring #5133-75
11	532 10 57-01	Washer Plate Shf 388 Sq Hole	77	532 12 35-83	Key Square 2 0 X 1845/ 1865
13	874 55 04-12	Bolt 1/4-28 Unf Gr 8 W/Patch	78	532 12 17-48	Washer 25/32 X 1-5/8 X 16 Ga
14	810 04 04-00	Washer Lock Hvy Helical	79	532 12 50-96	Key Woodruff #9 3/16 x 3/4
16	873 80 05-00	Nut Lock Hex w/lins 5/16-18	80	532 13 14-86	Arm Shift
18	874 78 06-16	Bolt, Fin Hex 3/8-16 UNC x 1 Gr. 5	81	532 16 55-94	Shaft Asm Cross 18"t
19	873 80 06-00	Nut Lock 3/8-16 Unc	82	532 12 37-82	Spring Torsion T/a
21	532 10 69-33	Knob	83	819 17 12-16	Washer 17/32 X 3/4 X 16 Ga
22	532 13 08-04	Rod Brake Blk Zinc 26 840	84	532 16 62-28	Link Transaxle
24	873 35 06-00	Nut Hex Jam 3/8-16 Unc	85	532 15 03-60	Nut Lock Center 1/4 - 28 FNTHD
25	532 10 68-88	Spring Rod Brake 2 00 Zinc	89	532 18 30-43	Console Shift STLT
26	819 13 13-16	Washer 13/32 X 13/16 X 16 Ga	96	532 12 47-88	Retainer Spring 1"
27	876 02 04-12	Pin Cotter 1/8 X 3/4 Cad	112	819 09 12-10	Washer 9/32 x 3/4 x 10 Ga.
28	532 17 57-65	Rod Brake Parking LT/YT	113	532 12 72-85	Strap Torque LT
29	532 07 16-73	Cap Brake Parking Black	116	872 14 06-08	Bolt Rdhd Sq Neck 3/8-16 x 1.0
30	532 17 49-73	Bracket Mtg Transaxle	120	873 90 06-00	Nut Lock Flg. 3/8-16 Unc
32	874 76 05-12	Bolt Hex Hd 5/16-18unc X 3/4	145	874 49 05-40	Bolt Hex 5/16-18 Gr. 5
34	532 17 55-78	Shaft Asm Pedal Foot	150	532 17 54-56	Spacer
35	532 12 01-83	Bearing Nylon Blk 629 Id	151	819 13 32-10	Washer 13/32 x 2 x 10 Ga.
36	819 21 16-16	Washer 21/32 X 1 X 16 Ga	156	532 16 60-02	Washer Srrted 5/16ID x 1.125
37	532 12 49-63	Pin Roll 3/16 X 1"	158	532 16 55-89	Bracket Shift Mount
38	532 17 91-14	Pulley Idler Composite	159	532 18 39-00	Hub Tapered Flange Shift Lt
39	874 76 06-48	Bolt Fin Hex 3/8-16 Unc x 3	161	872 14 04-06	Bolt Rdhd Sqnk 1/4-20 x 3/4 Gr 5
41	532 17 55-56	Keeper Belt Idler Flat	162	873 68 04-00	Nut Crownlock 1/4-20 Unc
47	532 12 77-83	Pulley Idler V Groove Plastic	163	874 78 04-16	Bolt Hex Fin 1/4-20 Unc x 1 Gr 5
48	532 15 44-07	Bellcrank Clutch Grnd Driv	164	819 09 10-10	Washer 5/8 x .281 x 10 Ga
49	532 12 32-05	Retainer Belt Style Spring	165	532 16 56-23	Bracket Pivot Lever
50	872 11 06-12	Bolt Carr. Sh. 3/8-16 x 1-1/2 Gr.5	166	532 16 68-80	Screw 5/16-18 x 5/8
51	873 68 06-00	Nut Crownlock 3/8-16 Unc	168	532 16 54-92	Bolt Shoulder 5/16-18 x .561
52	873 68 05-00	Nut Crownlock 5/16-18 Unc	169	532 16 55-80	Plate Fastening Lt
53	532 10 57-10	Link Clutch	170	532 17 83-94	Keeper, Belt T/A D/P
55	532 10 57-09	Spring Return Clutch 6 75	197	532 16 96-13	Nyliner Snap-In
56	817 06 06-20	Screw 3/8-16 x 3/4	198	532 16 95-93	Washer Nyl 7/8 ID x 105"
57	532 13 08-01	V-Belt Ground Drive 95 25	202	872 11 06-14	Bolt Carr. SH 3/8-16 x 1-3/4 Gr. 5
59	532 16 96-91	Keeper Belt Span Ctr	212	532 14 52-12	Nut, Hex Flange Lock
61	817 12 06-14	Screw 3/8-16 x .875	263	817 00 06-12	Screw Hexwsh THDR 3/8-16 x 3/4
62	532 12 48-72	Cover Pedal Round	269	532 18 24-02	Guard Muffler OHV B&S RH
63	532 18 02-19	Engine Pulley			

NOTE: All component dimensions given in U.S. inches
1 inch = 25.4 mm

REPAIR PARTS

TRACTOR - MODEL NO. BL13542SBK (BL135107A), PRODUCT NO. 964 77 14-00

STEERING ASSEMBLY

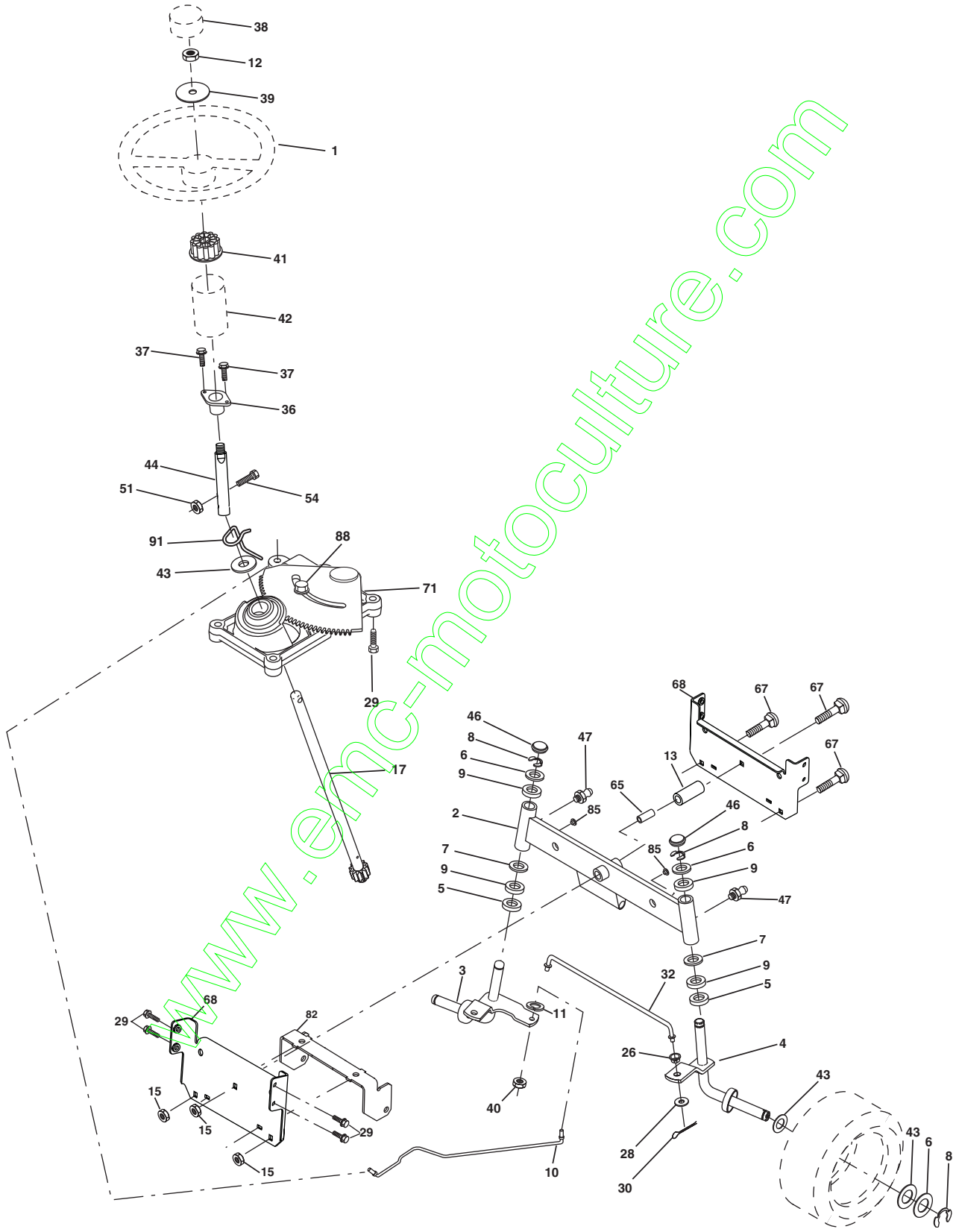

REPAIR PARTS

TRACTOR - MODEL NO. BL13542SBK (BL135107A), PRODUCT NO. 964 77 14-00

STEERING ASSEMBLY

KEY NO.	PART NO.	DESCRIPTION
1	532 13 97-68	Wheel Steering
2	532 17 51-31	Axle Asm
3	532 16 98-40	Spindle Asm LH
4	532 16 98-39	Spindle Asm RH
5	532 12 49-31	Bearing Race Thrust Harden
6	532 12 17-48	Washer 25/32 X 1-5/8 X 16 Ga
7	819 27 20-16	Washer 27/32 X 1-1/4 X 16 Ga
8	812 00 00-29	Ring Klip #t5304-75
9	532 12 49-37	Bearing Col Strg Blk
10	532 17 51-21	Link Drag
11	810 04 06-00	Washer Lock Hvy Hlcl Spr 3/8
12	873 94 08-00	Nut Hex Jam Toplock 1/2-20 UNF
13	532 13 65-18	Bearing Axle STLT/GT
15	532 14 52-12	Nut Hexflange Lock
17	532 18 06-41	Shaft Asm Strg
26	532 12 68-47	Bushing Link Drag Blk LR
28	819 13 14-16	Washer 13/32 X 7/8 X 16 Ga
29	817 06 06-12	Screw 3/8-16x3/4 SMGML
30	876 02 04-12	Pin Cotter 1/8 X 3/4 Cad
32	532 13 04-65	Rod Tie Wire Form 19 75 Mech
36	532 15 50-99	Bushing Strg
37	532 15 29-27	Screw
38	532 14 01-75	Insert Cap Strg Wh
39	819 18 38-12	Washer 9/16 ID x 2-3/8 OD 12 Ga.
40	532 12 47-01	Lock nut
41	532 10 07-11	Adaptor Wheel Strg
42	532 16 96-33	Boot Steering Shaft
43	532 12 17-49	Washer 25/32 X 1 1/4 X 16 Ga
44	532 18 06-40	Extension Steering Shaft
46	532 12 12-32	Cap Spindle Fr Top Blk
47	532 18 32-26	Fitting Grease
51	873 54 04-00	Nut Crownlock
54	871 13 04-20	Bolt Hex 1/4-28 UNF x 1-1/4 Gr 8
65	532 16 03-67	Spacer Axle
67	872 14 06-18	Bolt RDHD SQNK 3/8-16 x 2-1/4
68	532 16 98-27	Axle, Brace
71	532 17 51-46	Steering Asm.
82	532 16 98-35	Bracket Susp Chassis Front
85	532 13 38-35	Fastner Christmas Tree
88	532 17 51-18	Bolt Shoulder 7/16-20 Unc
91	532 17 55-53	Clip Steering

NOTE: All component dimensions given in U.S. inches.
1 inch = 25.4 mm.

REPAIR PARTS

TRACTOR - MODEL NO. BL13542SBK (BL135107A), PRODUCT NO. 964 77 14-00

ENGINE

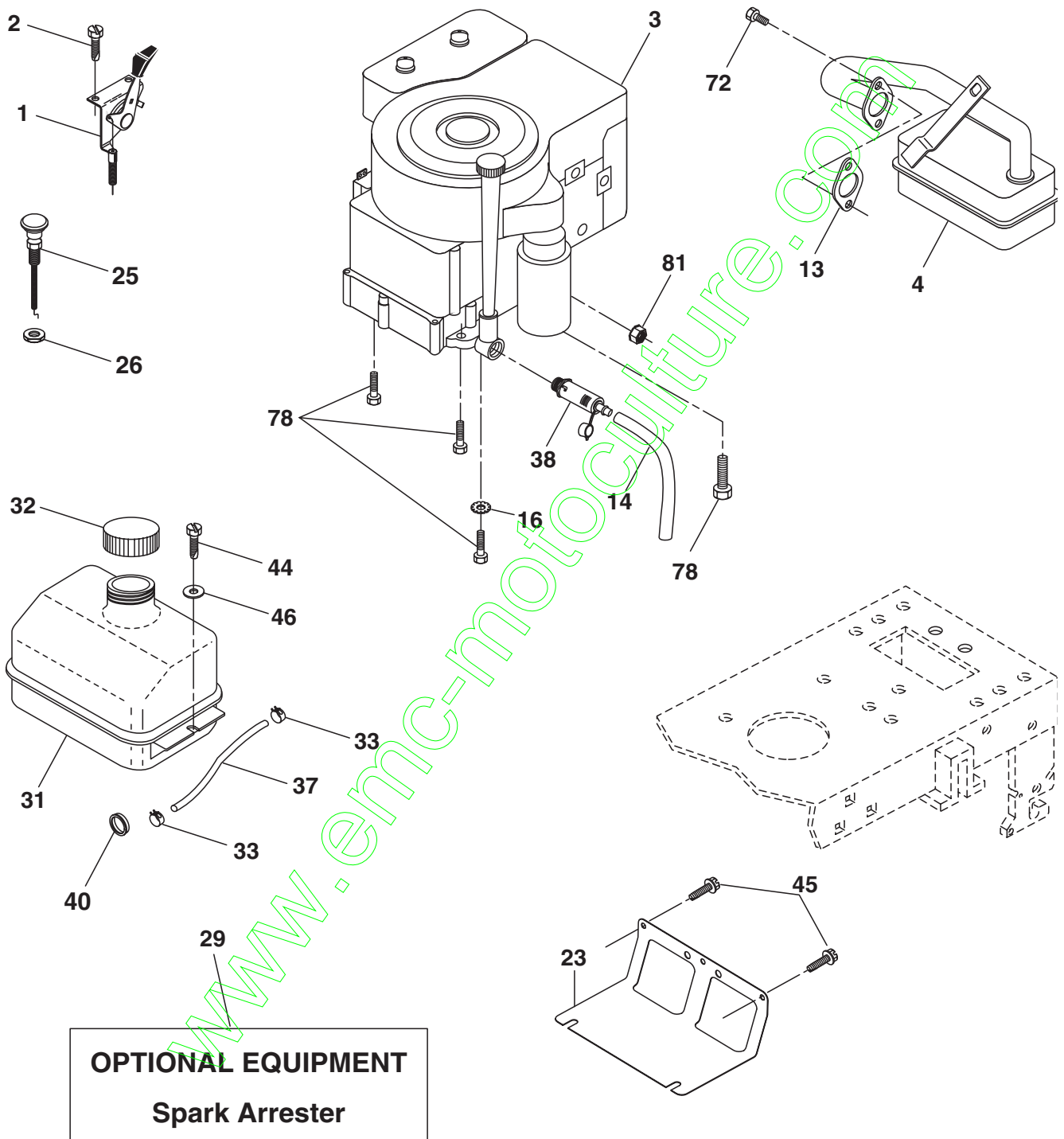

REPAIR PARTS

TRACTOR - MODEL NO. BL13542SBK (BL135107A), PRODUCT NO. 964 77 14-00

ENGINE

KEY NO.	PART NO.	DESCRIPTION
1	532 17 05-51	Control Th/ch LH Flag
2	817 72 04-08	Screw Hex Thd Cut 1/4-20 x 1/2
3	-----	Engine B&S Model No. 31G777 (Order parts from engine manufacturer)
4	532 13 73-52	Muffler
13	532 16 52-91	Gasket
14	532 14 84-56	Tube Drain Oil Easy
16	811 05 06-00	Washer Lock Ext Tooth 3/8
23	532 16 98-37	Shield Brn/Dbr Guard
25	532 18 09-45	Control Choke
26	873 92 06-00	Nut Keps 3/8-24
29	532 13 71-80	Kit Spark Arrestor (Flat Scrn)
31	532 18 49-00	Tank Fuel Front
32	532 14 05-27	Cap Asm Fuel W/sym Vented
33	532 12 34-87	Clamp Hose Black
37	532 13 70-40	Line Fuel 20"
38	532 18 16-54	Plug Drain Oil Easy
40	532 12 40-28	Bushing Snap Nyl Blk Fuel Line
44	817 67 04-12	Screw Hexwsh Thdrol 1/4-20x3/4
45	817 00 06-12	Screw 3/8-16 x 3/4
46	819 09 14-16	Washer 9/32 X 7/8 X 16 Ga
72	532 18 39-06	Screw Socket Head 5/16-18 x 1
78	817 06 06-20	Screw 3/8-16 x 1-1/4 SMGML
81	873 51 04-00	Nut Keps Hex 1/4-20

NOTE: All component dimensions given in U.S. inches
1 inch = 25.4 mm

REPAIR PARTS

TRACTOR - MODEL NO. BL13542SBK (BL135107A), PRODUCT NO. 964 77 14-00

SEAT ASSEMBLY

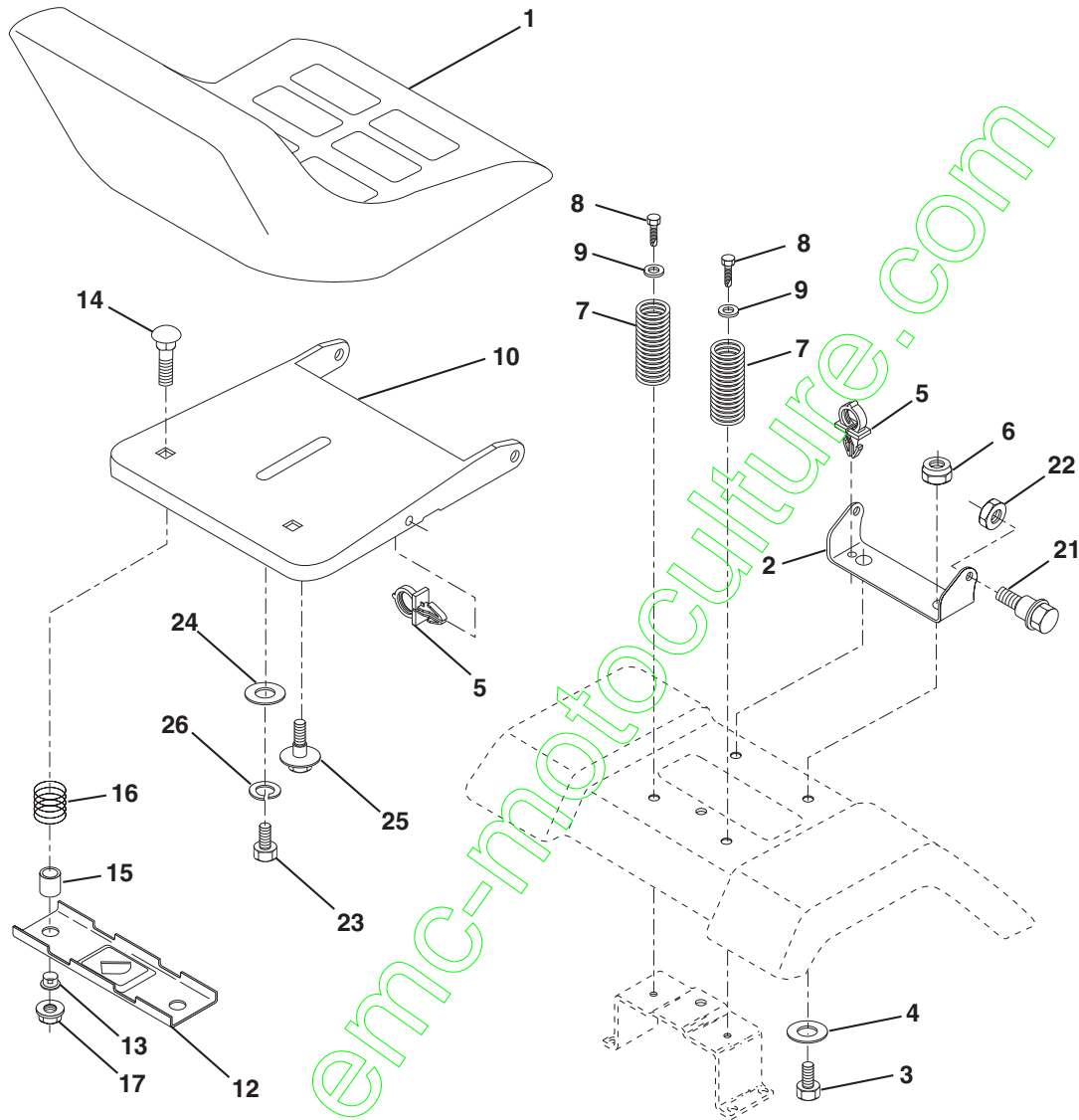

KEY NO.	PART NO.	DESCRIPTION
1	532 17 53-89	Seat
2	532 14 05-51	Bracket Pivot Seat 8 720
3	871 11 06-16	Bolt Fin Hex 3/8-16 Unc x 1
4	819 13 16-10	Washer 13/32 X 1 X 10 Ga
5	532 14 50-06	Clip Push-In
6	873 80 06-00	Nut Hex w/Ins. 3/8-16 Unc
7	532 12 41-81	Spring Seat Cprsn 2 250 Blk Zi
8	817 00 06-16	Screw 3/8-16 x 1.5 SMGML
9	819 13 16-14	Washer 13/32 X 1 X 14 Ga.
10	532 18 24-93	Pan Seat
12	532 12 12-46	Bracket Mounting Switch
13	532 12 12-48	Bushing Snap Blk Nyl 50 Id
14	872 05 04-12	Bolt Rdhd Sqnk 1/4-20x1-1/2

KEY NO.	PART NO.	DESCRIPTION
15	532 13 43-00	Spacer Split 28 x .96 YEL Zinc
16	532 12 12-50	Spring Cprsn 1.27
17	532 12 39-76	Nut Lock 1/4 Lge Flg Gr 5 Zinc
21	532 17 18-52	Bolt SHLD 5/16-18 Unc-2A
22	873 80 05-00	Nut Hex Lock W/Ins 5/16-18
23	871 11 08-14	Bolt Hex Black
24	819 17 19-12	Washer 17/32 X 1-3/16 X 12 Ga.
25	532 12 70-18	Bolt Shoulder 5/16-18 X 62
26	810 04 08-00	Washer Lock HVY HLCL SPR 1/2

NOTE: All component dimensions given in U.S. inches.
1 inch = 25.4 mm

REPAIR PARTS

TRACTOR - MODEL NO. BL13542SBK (BL135107A), PRODUCT NO. 964 77 14-00

DECALS

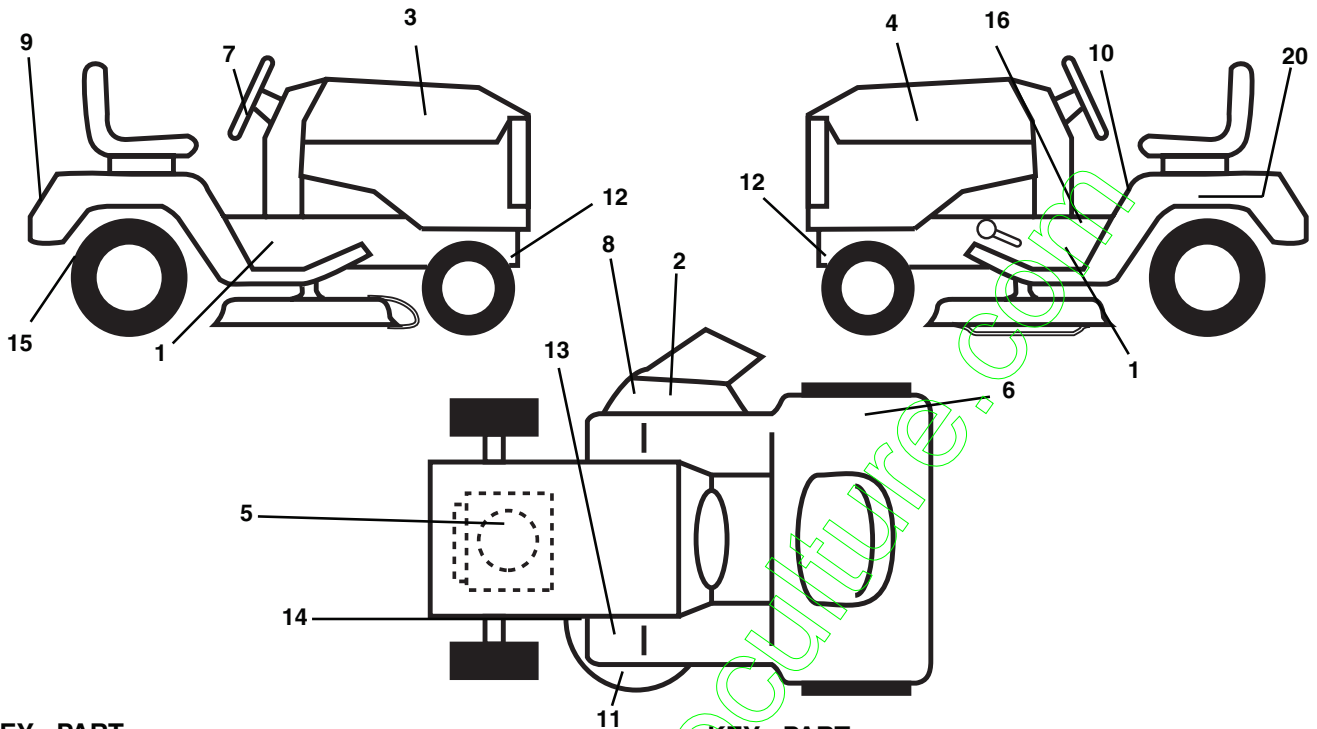

KEY NO.	PART NO.	DESCRIPTION
1	532 18 56-65	Decal Chassis 42 6 Sp
2	532 17 91-28	Decal Deck
3	532 18 56-60	Decal Hood RH
4	532 18 56-62	Decal Hood LH
5	532 18 04-31	Decal HP Engine
6	532 18 04-32	Decal Europe Stand 100 DB/CE
7	532 18 56-67	Decal, Ins. Strg Whl.
8	532 18 21-66	Decal Mower Cutting
9	532 18 56-66	Decal Fender Bernard
10	532 14 54-98	Decal Read Owner's Manual Syms.

KEY NO.	PART NO.	DESCRIPTION
11	532 13 49-99	Decal Deck
12	532 15 97-36	Decal Chassis Hot Muffler
13	532 15 97-37	Decal Brake/Clutch Symbol LT
14	532 16 03-96	Decal V-Belt Schematic
15	532 16 25-98	Decal Drawbar Load Limit
16	532 14 08-37	Decal Saddle Brake Parking
20	532 14 50-05	Decal Bat Dan/Psn
--	532 13 83-11	Decal Handle Lift Height Adjust
--	532 18 52-39	Manual Operator's (Euro.)

WHEELS & TIRES

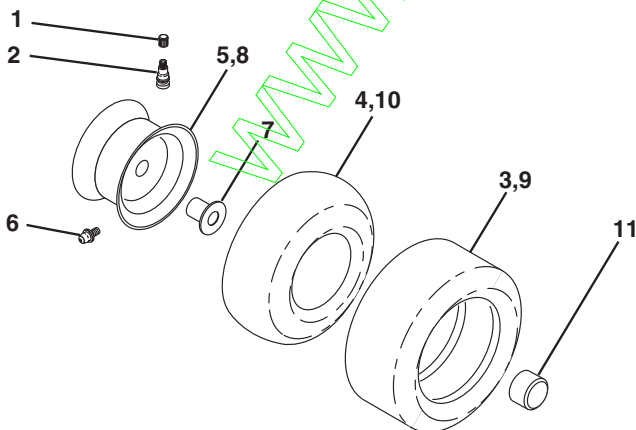

KEY NO.	PART NO.	DESCRIPTION
1	532 05 91-92	Cap Valve Tire
2	532 06 51-39	Stem Valve
3	532 10 62-22	Tire F Ts 15 X 6 0 - 6 Service
4	532 05 99-04	Tube Front (Service Item Only)
5	532 12 51-21	Rim Asm 6" front Yellow Service
6	532 12 49-57	Fitting Grease (Front Wheel Only)
7	532 12 49-59	Bearing Flange (Front Wheel Only)
8	532 12 51-22	Rim Asm 8" rear Yellow Service
9	532 12 46-35	Tire R Ts 18x8.5-8 C Service
10	532 12 49-26	Tube Rear (Service Item Only)
11	532 17 50-39	Cap Axle Blk 1 50 X 1 00
--	532 14 43-34	Sealant, Tire (10 oz. Tube)

NOTE: All component dimensions given in U.S. inches
1 inch = 25.4 mm

REPAIR PARTS

TRACTOR - MODEL NO. BL13542SBK (BL135107A), PRODUCT NO. 964 77 14-00
MOWER DECK

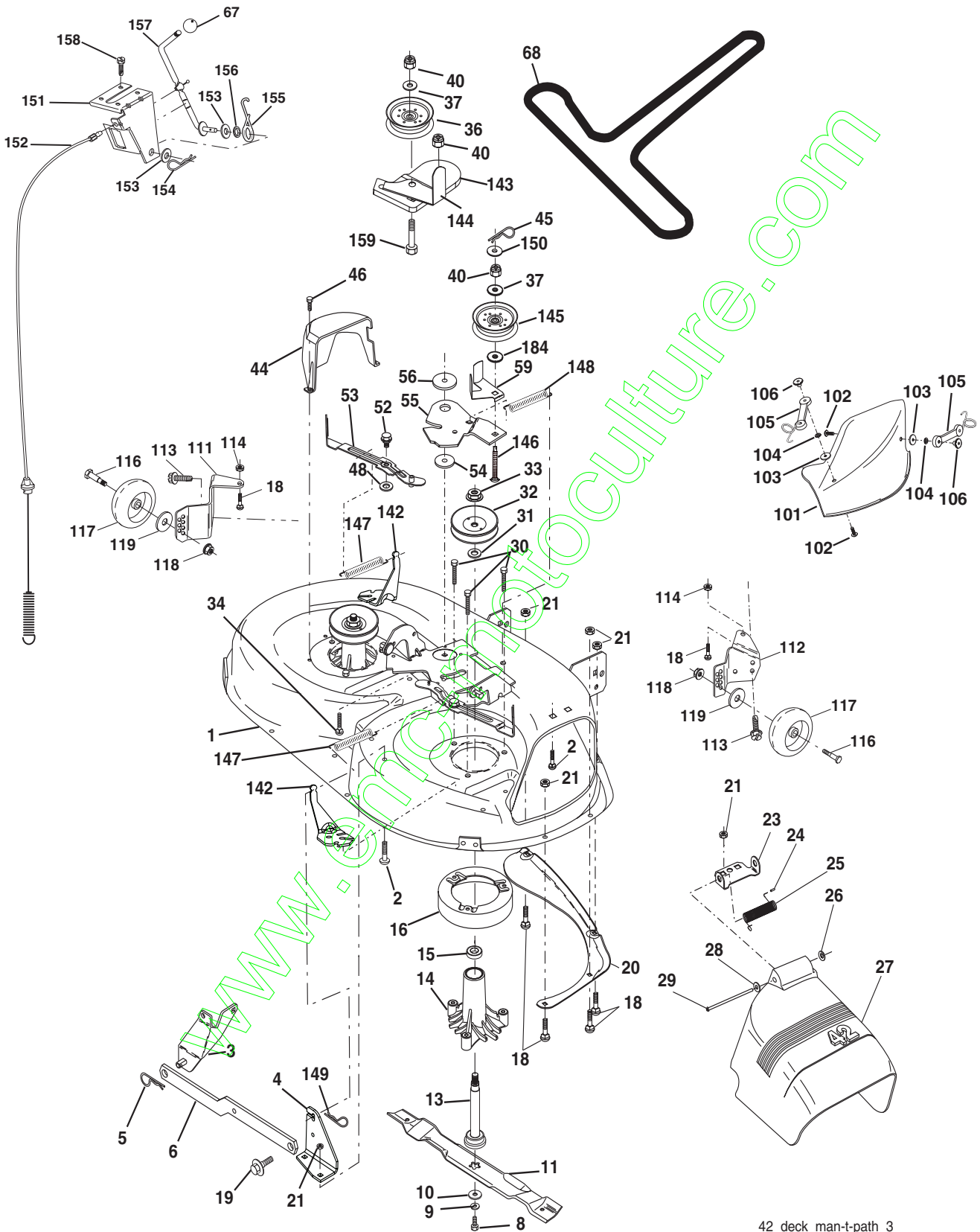

42_deck_man-t-path_3

REPAIR PARTS

TRACTOR - MODEL NO. BL13542SBK (BL135107A), PRODUCT NO. 964 77 14-00

MOWER DECK

KEY NO.	PART NO.	DESCRIPTION	KEY NO.	PART NO.	DESCRIPTION
1	532 16 58-92	Housing Asm Mower	68	532 18 02-15	V-Belt Mower
2	872 14 05-06	Bolt Rdhd Sqnk 5/16-18unc X3/4	101	532 13 64-20	Cover Mulching
3	532 13 80-17	Bracket Asm Fr Sway Bar 38/42	102	871 08 10-10	Screw Pan HD 10-24 x 5/8
4	532 16 54-60	Bracket Asm Deck 42"sway Bar	103	819 06 12-16	Washer #10
5	532 12 46-70	Retainer Spring	104	810 07 10-00	Washer Lock #10
6	532 17 80-24	Bar Sway Deck	105	532 16 07-93	Latch
8	532 85 08-57	Bolt 3/8-24x1 25 Gr8 Patched	106	532 12 50-04	Nut Weld .327/.304 #10 10-24
9	810 03 06-00	Washer Lock Hvy 3/8 Unplated	111	532 17 92-92	Bracket Gauge Wheel Lh
10	532 14 02-96	Washer Hard Blade Mower Vented	112	532 17 92-93	Bracket Gauge Wheel Rh
11	532 13 89-71	Blade Mower High Lift"	113	817 06 05-10	Screw Tapping 3/8-16 x .625
13	532 13 76-45	Shaft Asm W/lower Bearing	114	873 51 05-00	Nut Keps 5/16-18 UNC
14	532 12 87-74	Housing Mandrel Vented(machd)	116	532 12 48-42	Bolt Shoulder
15	532 11 04-85	Bearing Ball Mandrel	117	532 16 57-46	Wheel Gauge
16	532 17 44-93	Stripper Round Mower	118	873 93 06-00	Nut Centerlock 3/8-16 UNC
18	872 14 05-05	Bolt Carr 5/16-18 X 5/8	119	819 12 14-14	Washer 3/8 x 7/8 x 14 Ga.
19	532 13 28-27	Bolt Shoulder	142	532 16 58-90	Arm Spring Brake Mower
20	532 15 97-70	Baffle Vortex	143	532 15 71-09	Bracket Arm Idler 42"
21	873 68 05-00	Nut Crown Lock 5/16-18	144	532 15 86-34	Keeper Belt 42" Clutch Cable
23	532 17 75-63	Bracket Deflector Mower 42"	145	532 16 58-88	Pulley Idler Flat
24	532 10 53-04	Cap Sleeve 80x 112 Blk Mower	146	532 17 19-77	Bolt Carriage Idler
25	532 12 37-13	Spring Torsion Deflector 2 52	147	532 17 97-48	Spring Extension
26	532 11 04-52	Nut Push Phos & Oil	148	532 16 90-22	Spring Return Idler
27	532 17 18-59	Shield Deflector	149	532 16 58-98	Retainer Spring Yellow
28	819 11 10-16	Washer 11/32 X 5/8 X 16 Ga	150	819 09 12-16	Washer 9/32 x 3/4 x 16 Ga.
29	532 13 14-91	Rod Hinge 42"6 75 Wlg	151	532 16 96-70	Bracket Clutch Cable
30	532 17 39-84	Screw Thdrol Washer Head	152	532 18 15-55	Clutch Cable 42"
31	532 12 99-63	Washer Spacer Mower Vented	153	532 16 96-74	Washer Flat 3/8" Type B
32	532 15 35-35	Pulley Mandrel	154	532 16 96-75	Spring Retainer
33	532 17 83-42	Nut 9/16top Lock Flng Cntr	155	532 16 96-71	Spring Retention Lvr Cltch Cab
34	872 11 06-14	Bolt RDHD 3/8-16 UNC x 2-3/4 Gr.5	156	532 16 96-72	Spacer Clutch Cable
36	532 13 14-94	Pulley Idler Flat 3 060	157	532 16 96-69	Rod Clutch Cable 3/8"
37	819 13 13-16	Washer 13/32 X 13/16 X 16 Ga	158	817 72 04-08	Screw Hex Thd Cut 1/4-20 x 1/2
40	873 68 06-00	Nut Lock 3/8-16 Unc	159	872 14 06-14	Bolt Rdhd Sqnk 3/8-16 Unc x 1-3/4
44	532 14 00-88	Guard Mandrel LH Black	184	819 13 14-10	Washer 13/32 x 7/8 x 10 Ga
45	532 12 47-88	Spring Retainer 1" Zinc/cad	--	532 18 13-85	Replacement Mower, Complete
46	532 13 77-29	Screw Thdrol 1/4-20x5/8	--	532 13 41-49	Blade Mulching 42"
48	532 13 39-44	Washer Hardened Samller	--	532 13 07-94	Mandrel Assembly (Includes Housing, Shaft and Shaft Hardware Only-Pulley Not Included)
52	532 13 98-88	Bolt Shoulder 5/16-18 Unc Blkz			
53	532 18 49-07	Arm Asm Pad Brake			
54	532 17 85-15	Washer Hardened			
55	532 15 50-46	Arm Idler 42"mower LT/YT			
56	532 16 57-23	Spacer Retainer Mower			
59	532 14 10-43	Guard, Belt			
67	532 10 69-32	Knob Rd 3/8-16 Plstc Thds Blk			

NOTE: All component dimensions given in U.S. inches
1 inch = 25.4 mm

REPAIR PARTS

TRACTOR - MODEL NO. BL13542SBK (BL135107A), PRODUCT NO. 964 77 14-00
MOWER LIFT

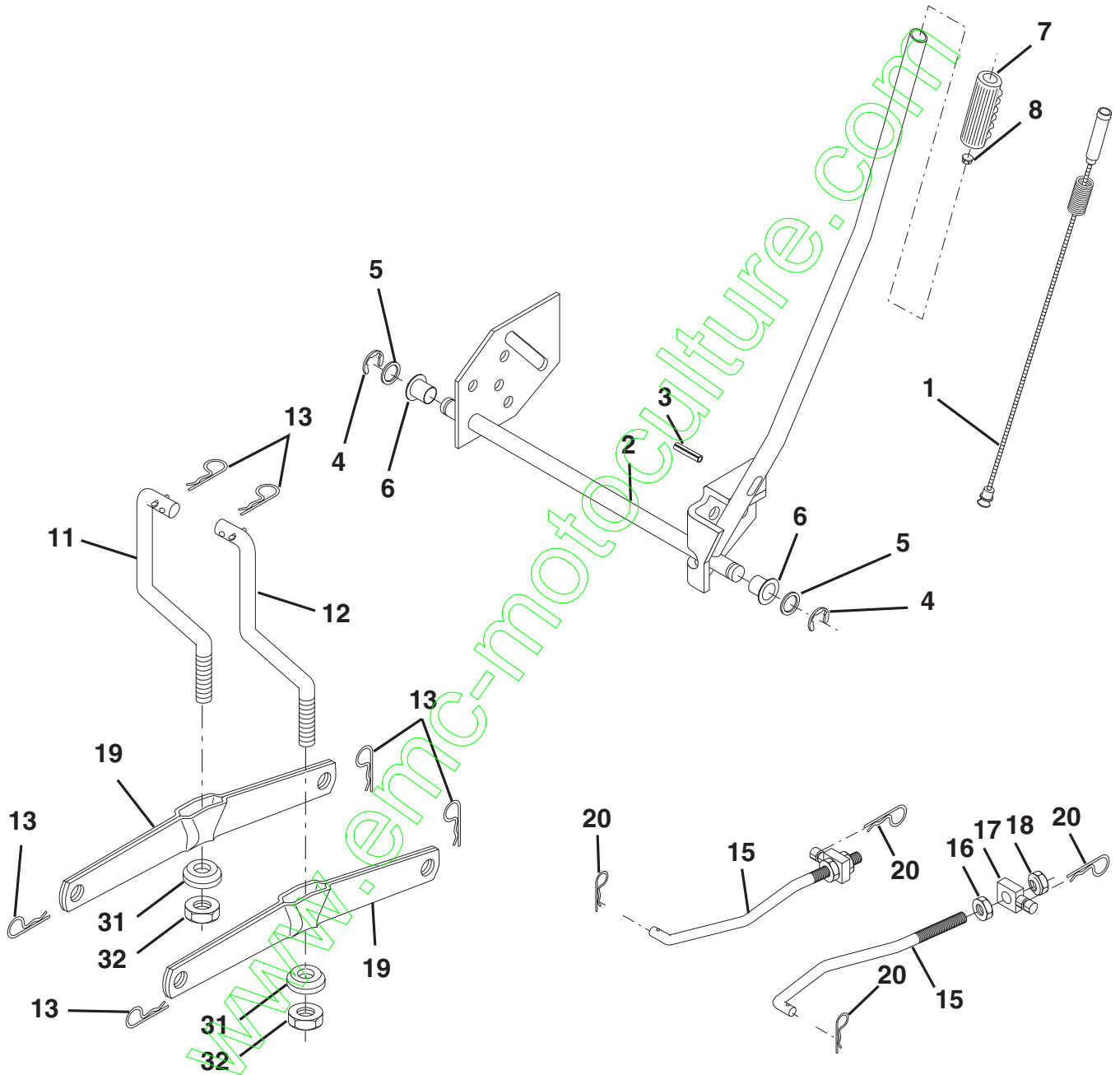

REPAIR PARTS

TRACTOR - MODEL NO. BL13542SBK (BL135107A), PRODUCT NO. 964 77 14-00

MOWER LIFT

KEY NO.	PART NO.	DESCRIPTION
1	532 15 94-60	Washer Asm Inner Spring W/Plunger
2	532 15 94-71	Shaft Asm. Lift
3	532 10 57-67	Pin Groove
4	812 00 00-02	E Ring #5133-62
5	819 21 16-21	Washer 21/32 x 1 x 21 Ga
6	532 12 01-83	Bearing Nylon
7	532 10 94-13	Grip Handle
8	532 12 45-26	Button Plunger
11	532 13 98-65	Link Lift LH
12	532 13 98-66	Link Lift RH
13	532 12 46-70	Retainer Spring
15	532 17 32-88	Link Front
16	873 35 08-00	Nut Jam Hex 1/2-13 Unc
17	532 17 56-89	Trunnion
18	873 80 08-00	Nut Lock W/Wsh 1/2-13 Unc
19	532 13 98-68	Arm Suspension Mower
20	532 16 35-52	Retainer Spring
31	532 16 98-65	Bearing Pvt. Lift
32	873 54 06-00	Nut Crownlock 3/8-24

NOTE: All component dimensions given in U.S. inches
1 inch = 25.4 mm

REPAIR PARTS

TRACTOR - MODEL NO. BL13542SBK (BL135107A), PRODUCT NO. 964 77 14-00

SCHEMATIC

