

ILLUSTRATED PARTS BREAKDOWN

BERNARD

15.5 HP LAWN TRACTOR

MODEL NO. BL15542SBHK (BL155H42SBA)

964 77 16-00

www.emc-motoculture.com

REPAIR PARTS

TRACTOR - MODEL NO. BL15542SBHK (BL155H42SBA), PRODUCT NO. 964 77 16-00
ELECTRICAL

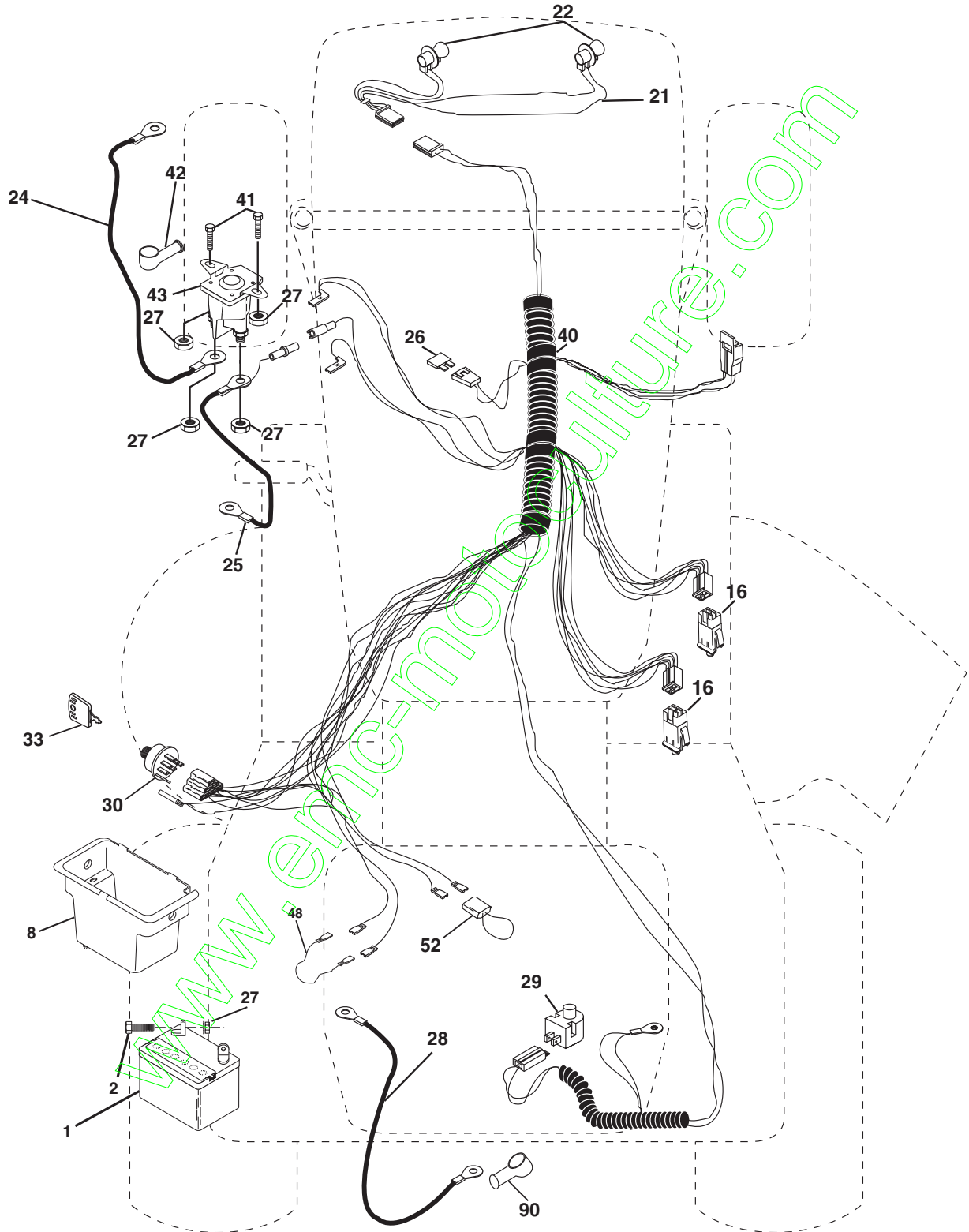

REPAIR PARTS

TRACTOR - MODEL NO. BL15542SBHK (BL155H42SBA), PRODUCT NO. 964 77 16-00
ELECTRICAL

KEY NO.	PART NO.	DESCRIPTION
1	532 1634-65	Battery
2	874 7604-12	Bolt Hex Hd 1/4-20unc X 3/4
8	532 1766-89	Case Battery Mech Hinge
16	532 1761-38	Switch Interlock
21	532 1756-88	Harness Asm Light W/4152j
22	532 0041-52	Bulb Light #1156
24	532 1247-80	Cable Battery 6 Ga 11" red
25	532 1461-47	Cable Battery 6 Ga 44" red w/16 wire
26	532 1751-58	Fuse 20 AMP
27	873 5104-00	Nut Keps Hex 1/4-20 Unc
28	532 1247-73	Cable Ground 6 Ga 12" black
29	532 1213-05	Switch Plunger Nc Gray
30	532 1755-66	Switch Ign
33	532 1404-01	Key Ign Molded Generic
40	532 1797-20	Harness Ign.
41	871 1104-08	Bolt Blk Fin Hex 1/4 - 20 x 1/2
42	532 1315-63	Cover Terminal Red
43	532 1788-61	Solenoid
48	532 1408-44	Adapter Ammeter Rectangular
52	532 1419-40	Protection Wire Loop
90	532 1804-49	Cover Terminal Battery

NOTE: All component dimensions given in U.S. inches.
1 inch = 25.4 mm.

REPAIR PARTS

TRACTOR - MODEL NO. BL15542SBHK (BL155H42SBA), PRODUCT NO. 964 77 16-00
CHASSIS AND ENCLOSURES

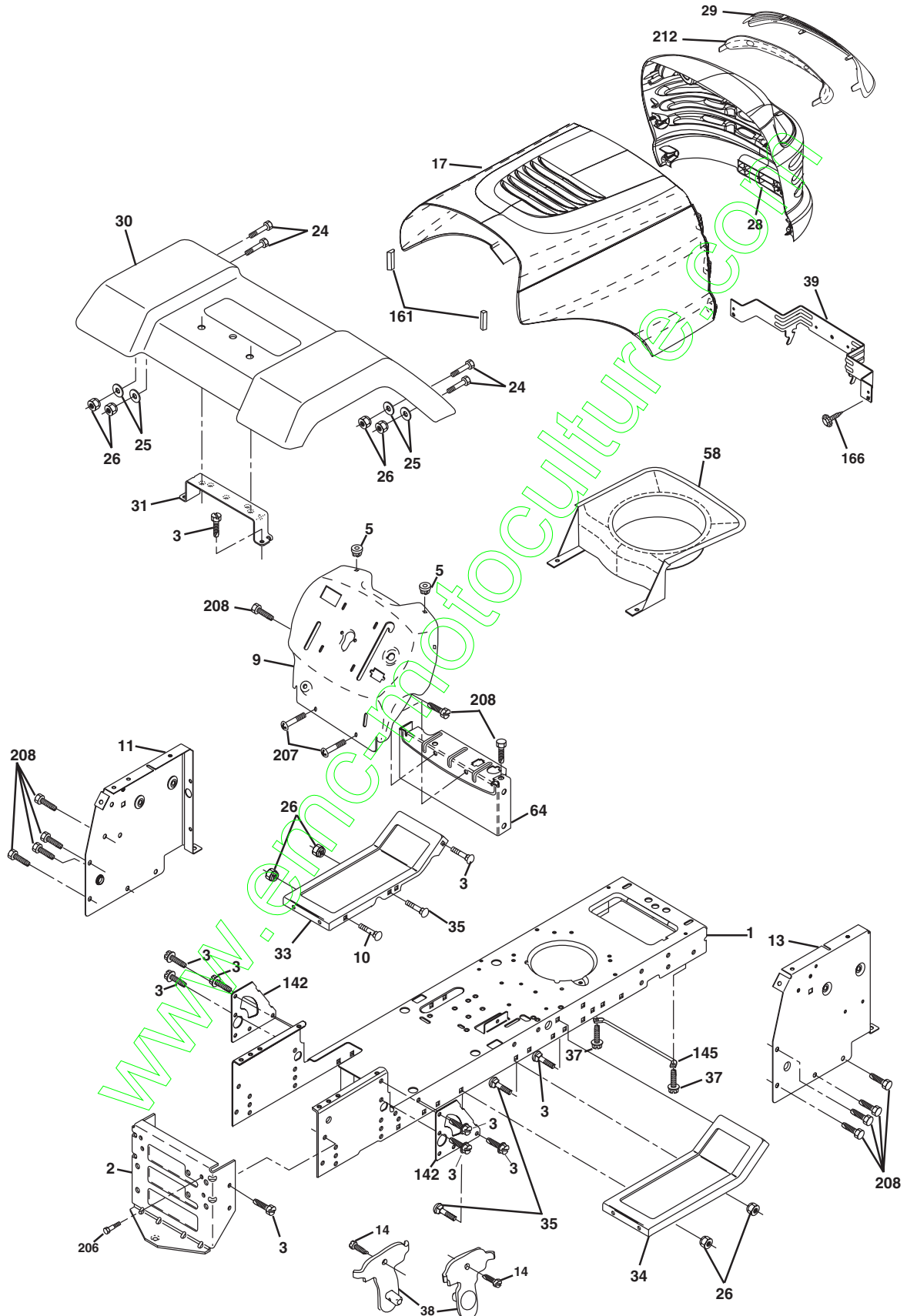

REPAIR PARTS

TRACTOR - MODEL NO. BL15542SBHK (BL155H42SBA), PRODUCT NO. 964 77 16-00
CHASSIS AND ENCLOSURES

KEY NO.	PART NO.	DESCRIPTION
1	532 17 46-19	Chassis Stamping
2	532 17 65-54	Drawbar, 12 Ga.
3	817 06 06-12	Screw 3/8-16 x 3/4
5	532 15 52-72	Bumper Hood/Dash
9	532 17 21-51	Dash Slkscr
10	872 14 06-08	Bolt Carriage 3/8-16 x 1
11	532 17 49-96	Panel Dash Lh
13	532 18 17-19	Panel Dash Rh
14	817 49 06-08	Screw Thdrol 3/8-16 x 1/2
17	532 18 29-07	Hood LT/PL
24	874 78 06-16	Bolt Fin Hex 3/8-16unc x 1 Gr 5
25	819 13 13-12	Washer 13/32 X 13/16 X 12 Ga
26	873 80 06-00	Nut Lock Hex W/Ins 3/8-16 Unc
28	532 17 97-49	Grille/Lens Asm
29	532 18 27-18	Lens P/L
30	532 17 30-26	Fender Footrest LTST Pnt
31	532 13 66-19	Bracket Fender
33	532 18 10-57	Footrest Pnt Lh
34	532 18 10-58	Footrest Pnt Rh
35	872 11 06-06	Bolt Rdhd Sht Sqnk 3/8-16 x 3/4
37	817 49 05-08	Screw Thdrol 6/16-18 x 1/2 TYT
38	532 17 57-10	Bracket Asm Pivot Mower Rear
39	532 17 47-14	Bracket Pivot Laser
58	532 15 01-27	Air Duct Engine P/L
64	532 15 47-98	Dash Lower STLT
142	532 17 57-02	Plate Reinforcement STLT
145	532 15 65-24	Rod Pivot Chassis/Hood
161	532 16 46-55	Bumper Extrusion
166	532 16 48-63	Screw HwHd Hi-Lo #13-16 x 3/4
206	532 17 01-65	Bolt Shoulder 5/16-18 TT
207	817 67 05-08	Screw Thdrol 5/16-18 x 1/2
208	817 67 06-08	Screw Thdrol 3/8-16x1/2 Ty-tt
212	532 17 51-43	Insert Lens Reflective
--	532 00 54-79	Plug Button

NOTE: All component dimensions given in U.S. inches
1 inch = 25.4 mm

REPAIR PARTS

TRACTOR - MODEL NO. BL15542SBHK (BL155H42SBA), PRODUCT NO. 964 77 16-00
DRIVE

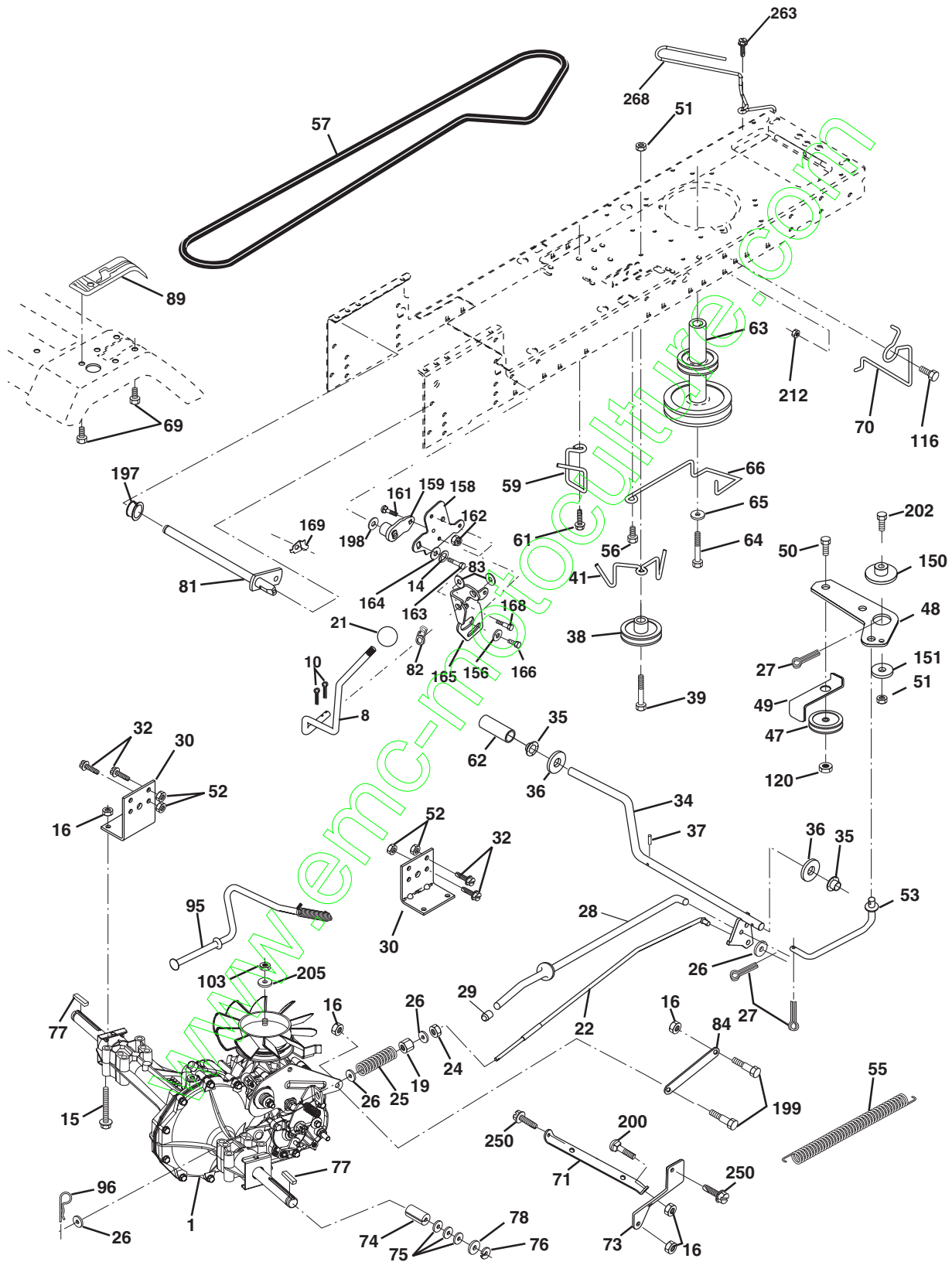

REPAIR PARTS

TRACTOR - MODEL NO. BL15542SBHK (BL155H42SBA), PRODUCT NO. 964 77 16-00
DRIVE

KEY NO.	PART NO.	DESCRIPTION	KEY NO.	PART NO.	DESCRIPTION
1	-----	Transaxle Hydro Gr Model 322-0510 (Order parts from transaxle mfg.)	73	532 16 91-82	Strap Torque Rh Hydro
8	532 16 56-19	Rod Shift Fender	74	532 13 70-57	Spacer, Axle
10	876 02 04-16	Pin Cotter 1/8 x 1 CAD	75	532 12 17-49	Washer 25/32 x 1-1/4 x 16 Gauge
14	810 04 04-00	Washer Lock Hvy Helical 1/4	76	812 00 00-01	E-Ring
15	874 49 05-44	Bolt Hex Flg Hd 5/16-18 X Gr.5	77	532 12 35-83	Key, Square
16	873 80 05-00	Nut Lock Hex W/Ins. 5/16-18 Unc P	78	532 12 17-48	Washer 25/32 x 1-5/8 x 16 Gauge
19	873 80 06-00	Nut Lock Hex W/Wsh 3/8-16 Unc	81	532 16 55-96	Shaft Asm. Cross Hydro
21	532 10 69-33	Knob, Deluxe	82	532 12 37-82	Spring Torsion T/A
22	532 16 94-98	Rod, Brake Hydro	83	819 17 12-16	Washer 17/32 x 3/4 x 16 Ga.
24	873 35 06-00	Nut	84	532 16 98-43	Link Transaxle
25	532 10 68-88	Spring, Brake Rod	89	532 17 30-29	Console, Shift
26	819 13 13-16	Washer	95	532 17 02-01	Control Asm Bypass Hydro
27	876 02 04-12	Pin Cotter 1/8 x 3/4 CAD.	96	532 12 47-88	Retainer Spring 1" Zinc/Cad
28	532 17 57-65	Rod, Parking Brake	103	873 94 08-00	Nut Hex Jam Toplock 1/2-20 Unf
29	532 07 16-73	Cap, Parking Brake	116	872 14 06-08	Boulon 3/8-16 x 1
30	532 17 49-73	Bracket, Transaxle	120	873 90 06-00	Nut Lock Flg 3/8-16
32	874 76 05-12	Bolt Hex Hd 5/16-18 Unc x 3/4	150	532 17 54-56	Spacer Retainer
34	532 17 55-78	Shaft, Foot Pedal	151	819 13 32-10	Washer 13/32 x 2 x 10 Ga.
35	532 12 01-83	Bearing, Nylon	156	532 16 60-02	Washer Srrtd 5/16 ID x 1.0 x .125 Tk
36	819 21 16-16	Washer	158	532 16 55-89	Bracket Shift Mount
37	532 12 49-63	Pin, Roll	159	532 16 54-94	Hub Tapered Flange Shift LT
38	532 17 91-14	Pulley, Composite	161	872 14 04-06	Bolt Rdhd Sqnk 1/4-20 x 3/4 Gr. 5
39	874 76 06-48	Bolt	162	873 68 04-00	Nut Crownlock 1/4-20 Unc
41	532 17 55-56	Keeper, Belt Idler	163	874 78 04-16	Bolt Hex Fin 1/4-20 unc x 1 Gr. 5
47	532 12 77-83	Pulley, Idler, V-Groove	164	819 09 10-10	Washer 5/8 x .281 x 10 Ga
48	532 15 44-07	Bellcrank Clutch Grnd Drv Stl	165	532 16 56-23	Bracket Pivot Lever
49	532 12 32-05	Retainer, Belt	166	532 16 68-80	Screw 5/16-18 x 5/8 TT Yellow
50	872 11 06-12	Bolt	168	532 16 54-92	Bolt Shoulder 5/16-18 x .561 TT
51	873 68 06-00	Nut	169	532 16 55-80	Plate Fastening Cross Shf. STLT/ CRD
52	873 68 05-00	Nut Crownlock 5/16-18	197	532 16 96-13	Nyliner Snap-In 5/8" ID
53	532 10 57-10	Link, Clutch	198	532 16 95-93	Washer Nyl. 7/8 ID x .105"
55	532 10 57-09	Spring, Return, Clutch	199	532 16 96-12	Bolt Shoulder 5/16-18 Unc
56	817 06 06-20	Screw 3/8-16 x 1-1/4	200	872 14 05-08	Bolt Rdhd Sq Neck 5/16-18unc x 1
57	532 14 02-94	V-Belt, Ground Drive	202	872 11 06-14	Bolt Carr Sh 3/8-16 x 1-3/4 Gr. 5
59	532 16 96-91	Keeper, Center Span	205	819 17 16-16	Washer 17/32 x 1 x 16 Ga.
61	817 12 06-14	Screw 3/8-16 x .875	212	532 14 52-12	Nut Hex Flg Lock
62	532 12 48-72	Cover, Pedal	250	817 06 06-12	Screw 3/8-16 x 3/4
63	532 18 02-19	Pulley, Eng	263	817 00 06-12	Screw 3/8-16 x 3/4
64	871 17 07-64	Bolt Hex 7/16-20 x 4 Ga. 5	268	532 18 24-02	Guard Muffler
65	810 04 07-00	Washer			
66	532 15 47-78	Keeper Belt Engine			
69	532 14 24-32	Screw Hex Wsh Hi-Lo 1/4-1/2 Unc			
70	532 18 02-18	Guide Belt Mower Drive RH			
71	532 16 91-83	Strap Torque Lh Hydro			

NOTE: All component dimensions give in U.S. inches.
1 inch = 25.4 mm.

REPAIR PARTS

TRACTOR - MODEL NO. BL15542SBHK (BL155H42SBA), PRODUCT NO. 964 77 16-00
STEERING ASSEMBLY

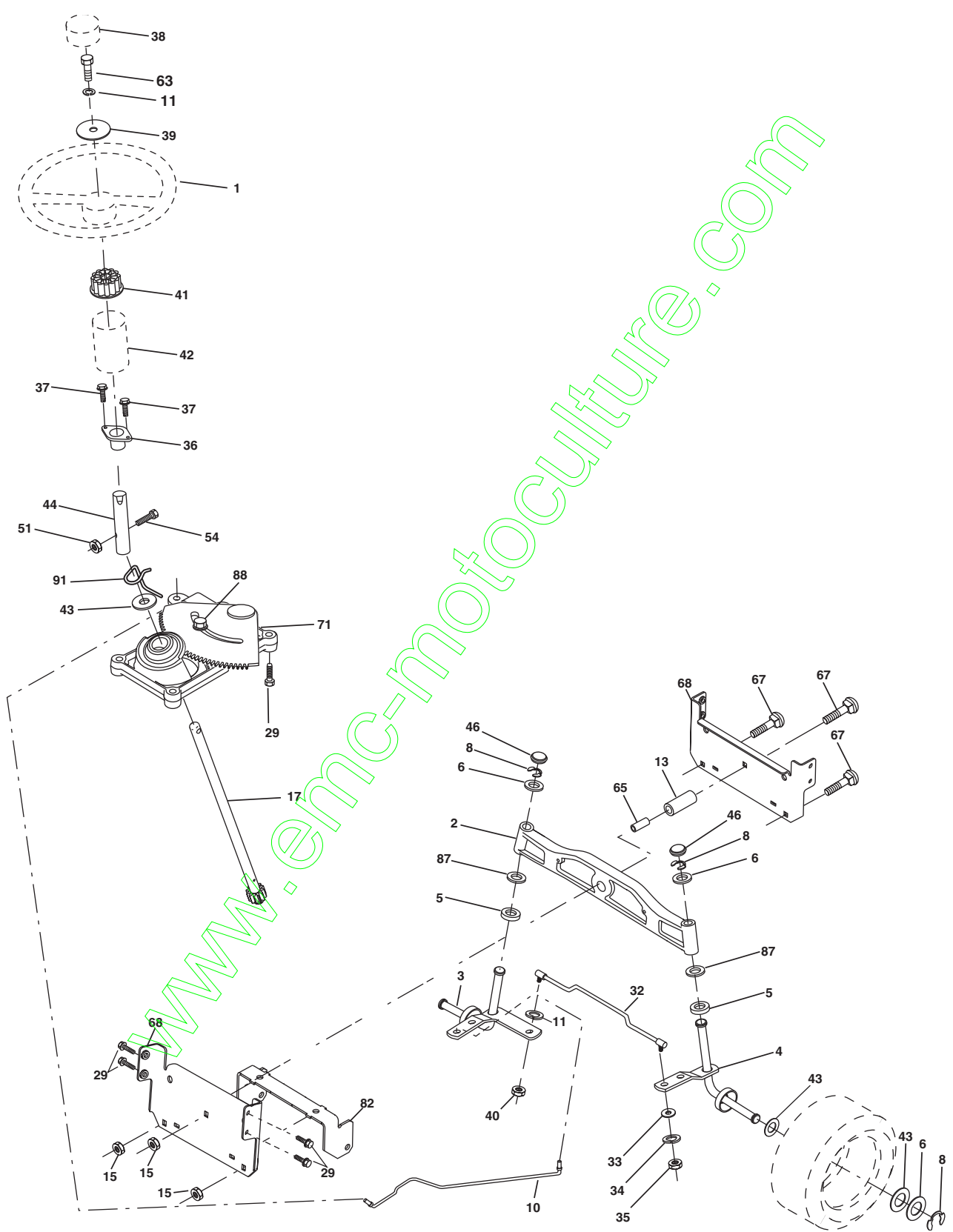

REPAIR PARTS

TRACTOR - MODEL NO. BL15542SBHK (BL155H42SBA), PRODUCT NO. 964 77 16-00
STEERING ASSEMBLY

KEY NO.	PART NO.	DESCRIPTION
1	532 13 97-68	Steering Wheel
2	532 17 51-31	Axle Assembly STMP Dropped STL
3	532 16 98-40	Spindle Assembly, L.H.
4	532 16 98-39	Spindle Assembly, R.H.
5	532 12 49-31	Bearing, Race, Thrust, Hardened
6	532 12 17-48	Washer 25/32 x 1-5/8 x 16 Gauge
7	819 27 20-16	Washer 27/32 x 1-1/4 x 16 Gauge
8	812 00 00-29	Ring, Klip
9	532 12 49-37	Bearing, Steering Column
10	532 17 51-21	Draglink Extended Stamped
11	810 04 06-00	Washer, Lock
13	532 13 65-18	Spacer Brg Axle Front
15	532 14 52-12	Hex Flange Lock
17	532 17 78-76	Shaft Assembly, Steering
26	532 12 68-47	Bushing, Link, Drag
28	819 13 14-16	Washer 13/32 x 7/8 x 16 Gauge
29	817 06 06-12	Screw, 3/8-16 x 3/4
30	876 02 04-12	Pin
32	532 13 04-65	Rod, Tie
36	532 15 50-99	Bushing, Steering
37	532 15 29-27	Screw
38	532 14 01-75	Insert, Steering Wheel
39	819 13 38-12	Washer 13/32 x 2-3/8 x 12 Gauge
40	532 12 47-01	Nut Lock Center 3/8-24Unf
41	532 10 07-11	Adaptor, Steering Wheel
42	532 16 96-33	Boot, Steering Shaft
43	532 12 17-49	Washer 25/32 x 1-1/4 x 16 Gauge
44	532 15 37-20	Extension Shaft Steering LR.LT
46	532 12 12-32	Cap, Spindle
47	532 18 32-26	Fitting, Grease
51	873 80 05-00	Nut Lock Hex w/Ins. 5/16-18 UNC
54	874 78 05-20	Bolt Fin Hex 5/16-18 UNC x 1-1/4
63	874 78 06-16	Bolt, Fin Hex 3/8-16 UNC x 1 Gr 5
65	532 16 03-67	Spacer Brace Axle
67	872 14 06-18	Bolt Rdhd Sq 3/8-16 x 2-1/4
68	532 16 98-27	Axle, Brace
71	532 17 51-46	Steering Asm
82	532 16 98-35	Bracket Susp Chassis Front
85	532 13 38-35	Fastner Christmas Tree
88	532 17 51-18	Screw 3/8-16 x 1
91	532 17 55-53	Clip Steering

NOTE: All component dimensions given in U.S. inches
1 inch = 25.4 mm

REPAIR PARTS

TRACTOR - MODEL NO. BL15542SBHK (BL155H42SBA), PRODUCT NO. 964 77 16-00
SEAT ASSEMBLY

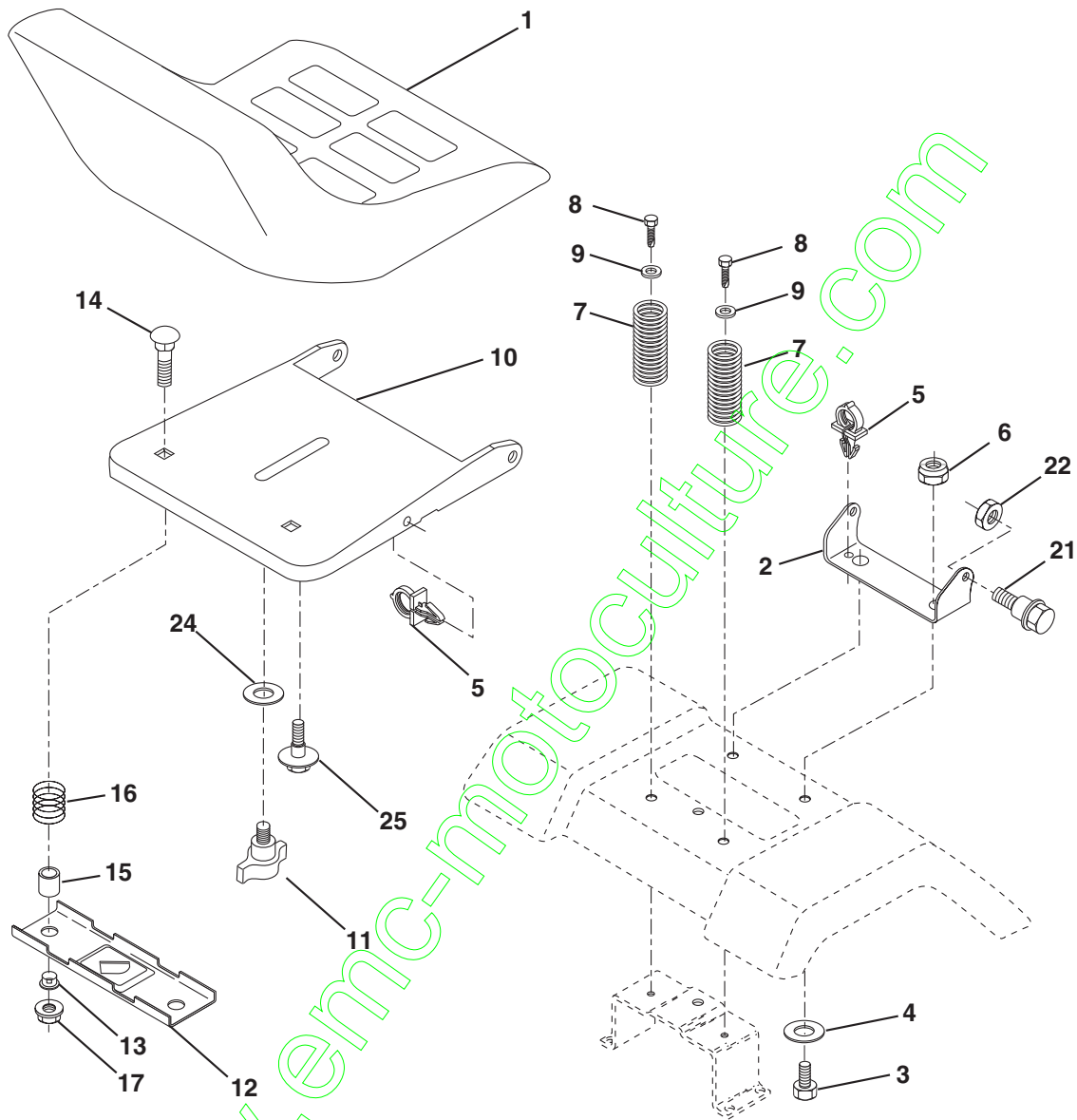

KEY NO.	PART NO.	DESCRIPTION
1	532 17 53-90	Seat
2	532 14 05-51	Bracket Pivot Seat 8 720
3	871 11 06-16	Bolt Fin Hex 3/8-16unc X 1
4	819 13 16-10	Washer 13/32 X 1 X 10 Ga
5	532 14 50-06	Clip Push-In
6	873 80 06-00	Nut Hex w/Ins. 3/8-16 Unc
7	532 12 41-81	Spring Seat Cprsn 2 250 Blk Zi
8	817 00 06-16	Screw 3/8-16 X 1
9	819 13 16-14	Washer 13/32 X 1 X 14 Ga.
10	532 18 24-93	Pan Seat
11	532 16 63-69	Knob Seat
12	532 12 12-46	Bracket Mounting Switch

KEY NO.	PART NO.	DESCRIPTION
13	532 12 12-48	Bushing Snap Blk Nyl 50 Id
14	872 05 04-12	Bolt Rdhd Sqnk 1/4-20x1-1/2
15	532 12 12-49	Spacer Split 28 x 88
16	532 12 37-40	Spring Cprsn 1.310 Blk Pnt
17	532 12 39-76	Nut Lock 1/4 Lge Flg Gr 5 Zinc
21	532 17 18-52	Bolt Shoulder 5/16-18 Unc-2A
22	873 80 05-00	Nut Hex Lock W/Ins 5/16-18
24	819 17 19-12	Washer 17/32 X 1-3/16 X 12 Ga.
25	532 12 70-18	Bolt Shoulder 5/16-18 X 62

NOTE: All component dimensions given in U.S. inches.
1 inch = 25.4 mm

REPAIR PARTS

TRACTOR - MODEL NO. BL15542SBHK (BL155H42SBA), PRODUCT NO. 964 77 16-00
DECALS

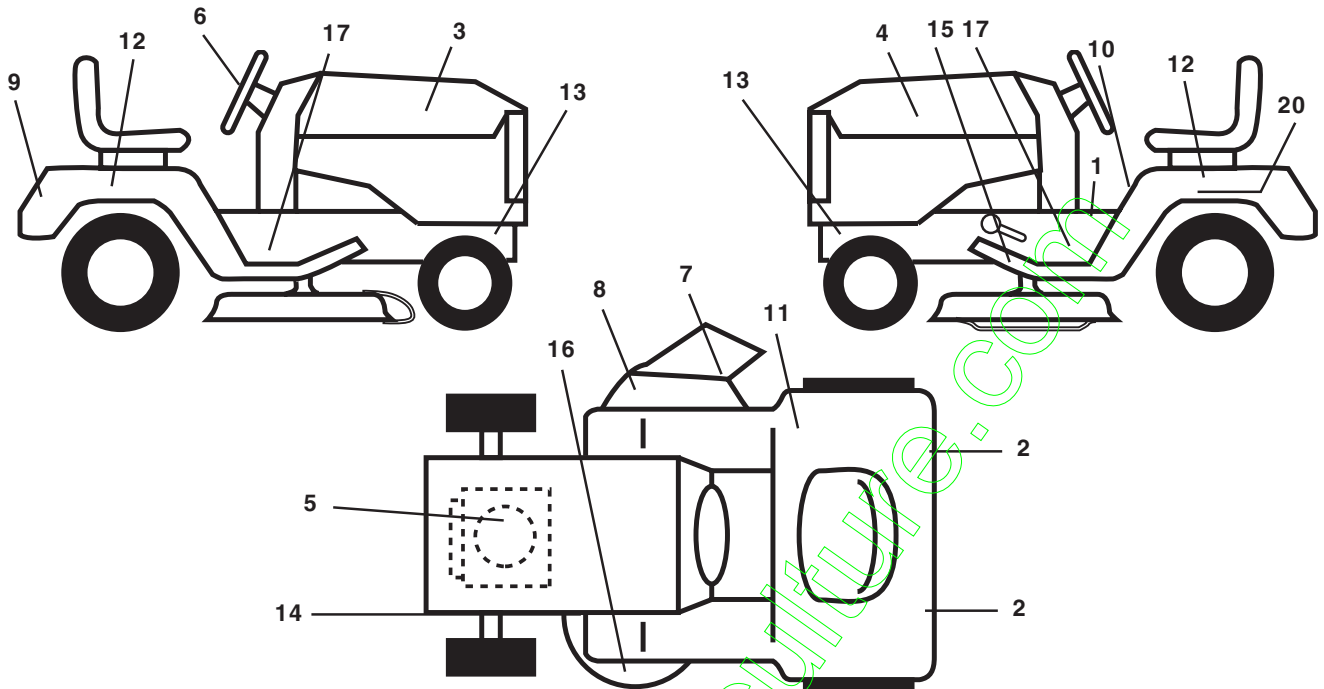

KEY NO.	PART NO.	DESCRIPTION
1	532 14 08-37	Decal Brake Parking Saddle
2	532 10 62-02	Reflector Tail Light Red/Amber
3	532 17 97-14	Decal Hood RH
4	532 17 97-15	Decal Hood LH
5	532 18 04-34	Decal Hood
6	532 16 62-85	Decal Wheel Steering
7	532 17 91-28	Decal Deck B 42
8	532 18 21-66	Decal Cutfinger
9	532 16 67-08	Decal Fender
10	532 14 54-98	Decal Read Owner's
11	532 18 04-32	Decal Fender 100DB/CE
12	532 17 13-00	Decal Fender Auto

KEY NO.	PART NO.	DESCRIPTION
13	532 15 97-36	Decal Chassis Muffler
14	532 16 03-96	Decal V-Belt Schematic
15	532 15 97-37	Decal Brake/Clutch Sym.
16	532 13 49-99	Decal Deck Enviro
17	532 15 76-37	Decal Chassis 42" Hydro
20	532 14 50-05	Decal Bat Dan/Psn
--	532 13 83-11	Decal Handle Lft Height Adjust
--	532 16 92-10	Decal Bypass Lt Hydro
--	532 18 10-90	Pad Footrest RH
--	532 18 10-91	Pad Footrest LH
--	532 16 25-98	Decal Drawbar
--	532 17 98-72	Manual Operator's Europ.

WHEELS & TIRES

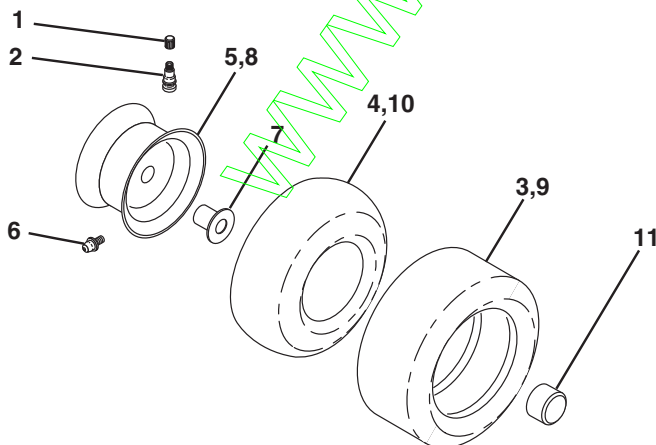

KEY NO.	PART NO.	DESCRIPTION
1	532 05 91-92	Cap Valve Tire
2	532 06 51-39	Stem Valve
3	532 10 62-22	Tire F Ts 15 X 6 0 - 6 Service
4	532 05 99-04	Tube Front (Service Item Only)
5	532 12 51-21	Rim Asm 6" front Service
6	532 12 49-57	Fitting Grease (Front Wheel Only)
7	532 12 49-59	Bearing Flange (Front Wheel Only)
8	532 12 51-22	Rim Asm 8" rear Service
9	532 10 62-68	Tire R Ts 18x9 5-8 C Service
10	532 12 49-26	Tube Rear (Service Item Only)
11	532 17 50-39	Cap Axle Blk 1 50 X 1 00
--	532 14 43-34	Sealant, Tire (10 oz. Tube)

NOTE: All component dimensions given in U.S. inches
1 inch = 25.4 mm

REPAIR PARTS

TRACTOR - MODEL NO. BL15542SBHK (BL155H42SBA), PRODUCT NO. 964 77 16-00
ENGINE

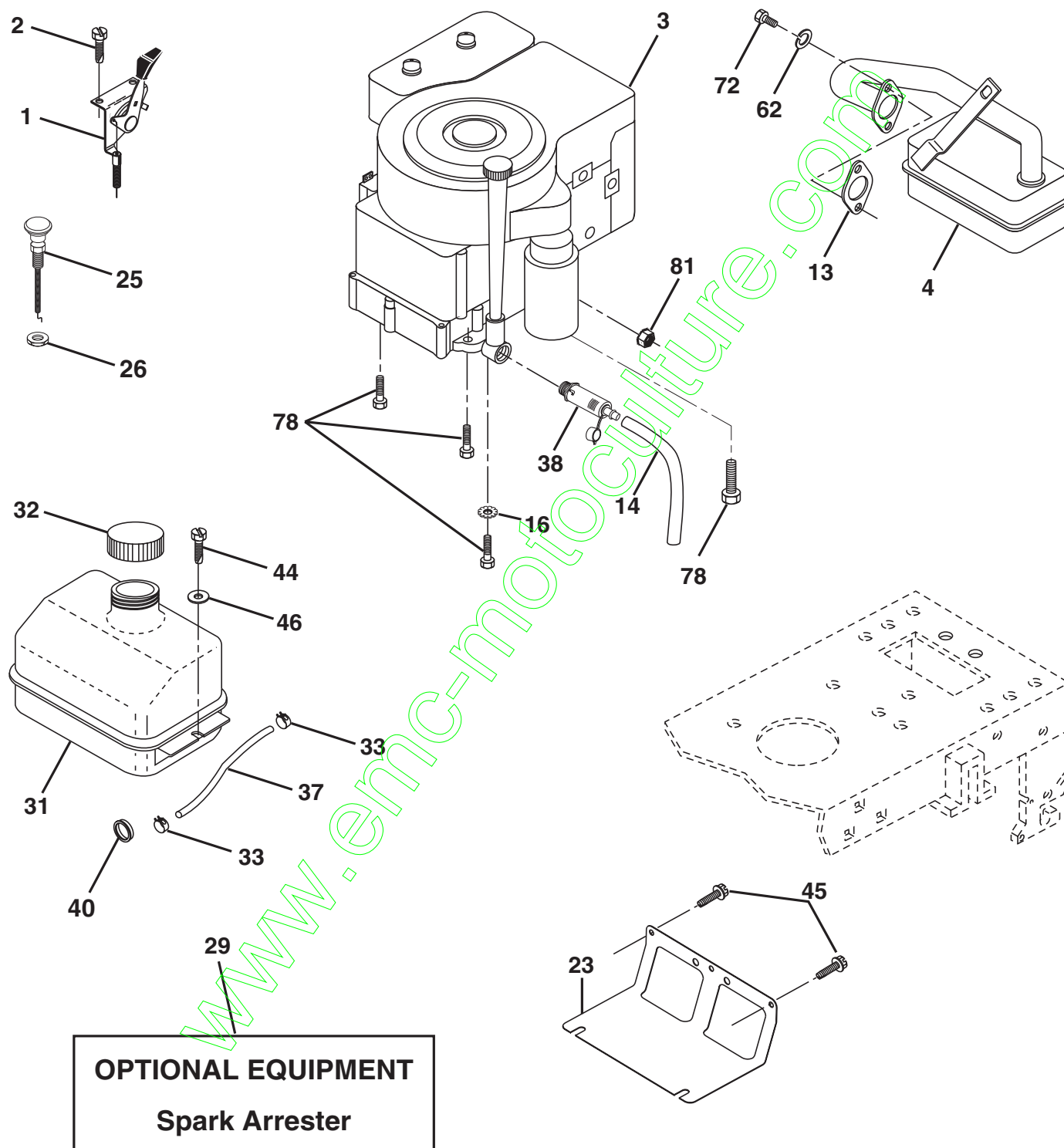

REPAIR PARTS

TRACTOR - MODEL NO. BL15542SBHK (BL155H42SBA), PRODUCT NO. 964 77 16-00
ENGINE

KEY NO.	PART NO.	DESCRIPTION
1	532 17 05-51	Control Th/ch Flag
2	817 72 04-08	Screw Hex Thd Cut 1/4-20x5/8 J
3	-----	Engine Briggs & Stratton 31G777 (Order Parts From Engine Manufacturer)
4	532 13 73-52	Muffler LT B&S 12/12.5/13HP
13	532 16 52-91	Gasket Eng 1 313 Id Tin Plated
14	532 14 84-56	Tube Drain Oil Easy
16	811 05 06-00	Washer Lock Ext Tooth 3/8
23	532 16 98-37	Shield Brn/Dbr Guard
25	532 18 09-45	Control Choke 1 Cyl. 02
26	873 92 06-00	Nut Keps 3/8-24 Unf
29	532 13 71-80	Kit Spark Arrestor (Flat Scrn)
31	532 10 92-02	Tank Fuel Front
32	532 14 05-27	Cap Asm Fuel W/sym Vented
33	532 12 34-87	Clamp Hose Black
37	532 13 70-40	Line Fuel 20"
38	532 14 83-15	Plug Drain Oil Easy
40	532 12 40-28	Bushing Snap Nyl Blk Fuel Line
44	817 67 04-12	Screw Hexwsh Thdrol 1/4-20x3/4
45	817 00 06-12	Screw Hex Wsh Thdrol 3/8-16 x 3/4
46	819 09 14-16	Washer 9/32 X 7/8 X 16 Ga
62	810 04 05-00	Washer Lock Hvy Hlcl Spr 5/16
72	871 07 05-12	Screw Hexhd Cap 5/16-18 x 3/4
78	817 06 06-20	Screw 3/8-16x1-1/4
81	873 51 04-00	Nut 1/4-20

NOTE: All component dimensions given in U.S. inches.
1 inch = 25.4 mm.

REPAIR PARTS

TRACTOR - MODEL NO. BL15542SBHK (BL155H42SBA), PRODUCT NO. 964 77 16-00
MOWER DECK

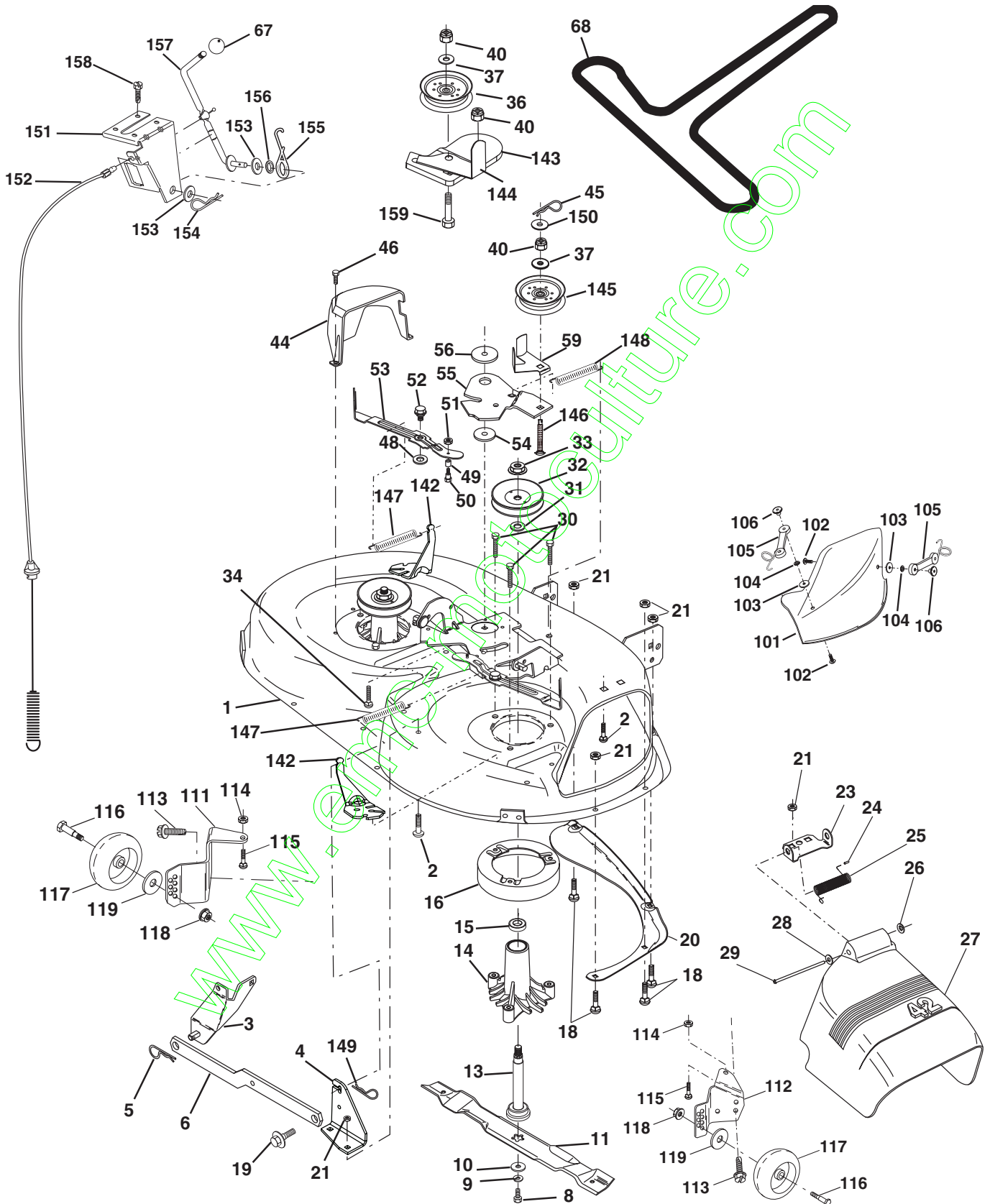

REPAIR PARTS

**TRACTOR - MODEL NO. BL15542SBHK (BL155H42SBA), PRODUCT NO. 964 77 16-00
MOWER DECK**

KEY NO.	PART NO.	DESCRIPTION	KEY NO.	PART NO.	DESCRIPTION
1	532 16 58-92	Deck Asm MWR 42"weldment	56	532 16 57-23	Spacer Retainer Mower
2	872 14 05-06	Bolt Rdhd Sqnk 5/16-18unc X3/4	59	532 14 10-43	Guard TUV Idler
3	532 13 80-17	Bracket Asm Fr Sway Bar 38/42	67	532 10 69-32	Knob Rd 3/8-16 Plstc Thds Blk
4	532 16 54-60	Bracket Asm Deck 42"sway Bar	68	532 18 02-15	V-Belt Mower 42"
5	532 12 46-70	Retainer Spring	101	532 13 64-20	Cover Mulch 42"
6	532 17 80-24	Deck Sway Bar	102	871 08 10-10	Screw Pan Head Phillip 10-24 x 5/8
8	532 85 08-57	Bolt 3/8 - 24 X 1.25 Gr 8	103	819 06 12-16	Washer #10
9	810 03 06-00	Washer Lock Hvy 3/8	104	810 07 10-00	Washer Lock #10
10	532 14 02-96	Washer Hard Blade Mower Vented	105	532 16 07-93	Latch Asm. Mulch
11	532 13 84-98	Blade Mower 42"	106	532 12 50-04	Nut Weld #10-24
13	532 13 76-45	Shaft Asm W/lower Bearing	111	532 17 92-92	Bracket Wheel Gauge LH 42" Deck
14	532 12 87-74	Housing Mandrel Vented	112	532 17 92-93	Bracket Gauge Wheel RH 42" Deck
15	532 11 04-85	Bearing Ball Mandrel	113	817 06 05-10	Screw Tapping 3/8-16 x .625
16	532 17 44-93	Stripper Mower	114	873 51 05-00	Nut Keps 5/16-18 Unc
18	872 14 05-05	Bolt Rdhd Sqnk 5/16-18 X 5/8	115	872 11 05-05	Bolt Carriage 5/16-Unc x 5/8
19	532 13 28-27	Bolt Shoulder	116	532 12 48-42	Bolt Shoulder
20	532 15 97-70	Baffle Vortex 42	117	532 16 57-46	Wheel Gauge
21	873 68 05-00	Nut Crownlock 5/16-18 UNC	118	873 93 06-00	Nut Centerlock 3/8-16 UNC
23	532 17 75-63	Bracket Deflector Mower 42"	119	819 12 14-14	Washer 3/8 x 7/8 x 14 Ga.
24	532 10 53-04	Cap Sleeve 80x 112 Blk Mower	142	532 16 58-90	Arm Spring Brake Mower
25	532 12 37-13	Spring Torsion Deflector 2 52	143	532 15 71-09	Bracket Arm Idler 42"
26	532 11 04-52	Nut Push Phos & Oil	144	532 15 86-34	Keeper Belt 42" Clutch
27	532 17 18-59	Shield Deflector Mower 42" Blk	145	532 16 58-88	Pulley Idler Flat
28	819 11 10-16	Washer 11/32 X 5/8 X 16 Ga	146	532 17 19-77	Bolt Carriage Idler
29	532 13 14-91	Rod Hinge 42"6 75 Wlg	147	532 17 97-48	Spring Extension
30	532 17 39-84	Screw Thd Rolling	148	532 16 90-22	Spring Return Idler
31	532 12 99-63	Washer Spacer Mower Vented	149	532 16 58-98	Retainer Spring Yellow
32	532 15 35-85	Pulley Mandrel 42"	150	819 09 12-16	Washer 9/32 x 3/4 x 16 Ga.
33	532 17 83-42	Nut Toplock Flng	151	532 16 96-70	Bracket Clutch Cable
34	872 11 06-14	Bolt Rdhd 3/8-16uncx1-3/4 Gr5	152	532 18 15-55	Clutch Cable 42"
36	532 13 14-94	Pulley Idler Flat 3 060	153	532 16 96-74	Washer Flat 3/8" Type B
37	819 13 13-16	Washer 13/32 X 13/16 X 16	154	532 16 96-75	Spring Retainer
40	873 68 06-00	Nut Crownlock 3/8-16 UNC	155	532 16 96-71	Spring Retention Lvr Cltch Cab
44	532 14 00-88	Guard Mandrel LH Black	156	532 16 96-72	Spacer Clutch Cable
45	532 12 47-88	Spring Retainer 1" Zinc/cad	157	532 16 96-69	Rod Clutch Cable 3/8"
46	532 13 77-29	Screw Hex Thd Cut 1/4-20 x 5/8 T	158	817 72 04-08	Screw Hex Thd Cut 1/4-20 x 1/2
48	532 13 39-44	Washer Hardened Smaller	159	872 14 06-14	Bolt Rdhd Sqn 3/8-16 Unc x 1-3/4
49	532 17 42-84	Roller Asm Cam Follower 42"dec	--	532 13 07-94	Mandrel Assembly(Includes Housing, Shaft and Shaft Hardware Only-Pulley not Included)
50	532 13 13-40	Bolt Shldr 10-24 Zinc Gr 5 42"	--	532 18 13-85	Replacement Mower, Complete
51	532 06 91-80	Nut Lock #10-24 Unc			
52	532 13 98-88	Bolt Shoulder 5/16-18 Unc Blkz			
53	532 13 18-45	Arm Asm Pad Brake			
54	532 13 39-43	Washer Hardened			
55	532 15 50-46	Arm Idler 42"mower LT/YT			

NOTE: All component dimensions given in U.S. inches
1 inch = 25.4 mm

REPAIR PARTS

TRACTOR - MODEL NO. BL15542SBHK (BL155H42SBA), PRODUCT NO. 964 77 16-00
MOWER LIFT

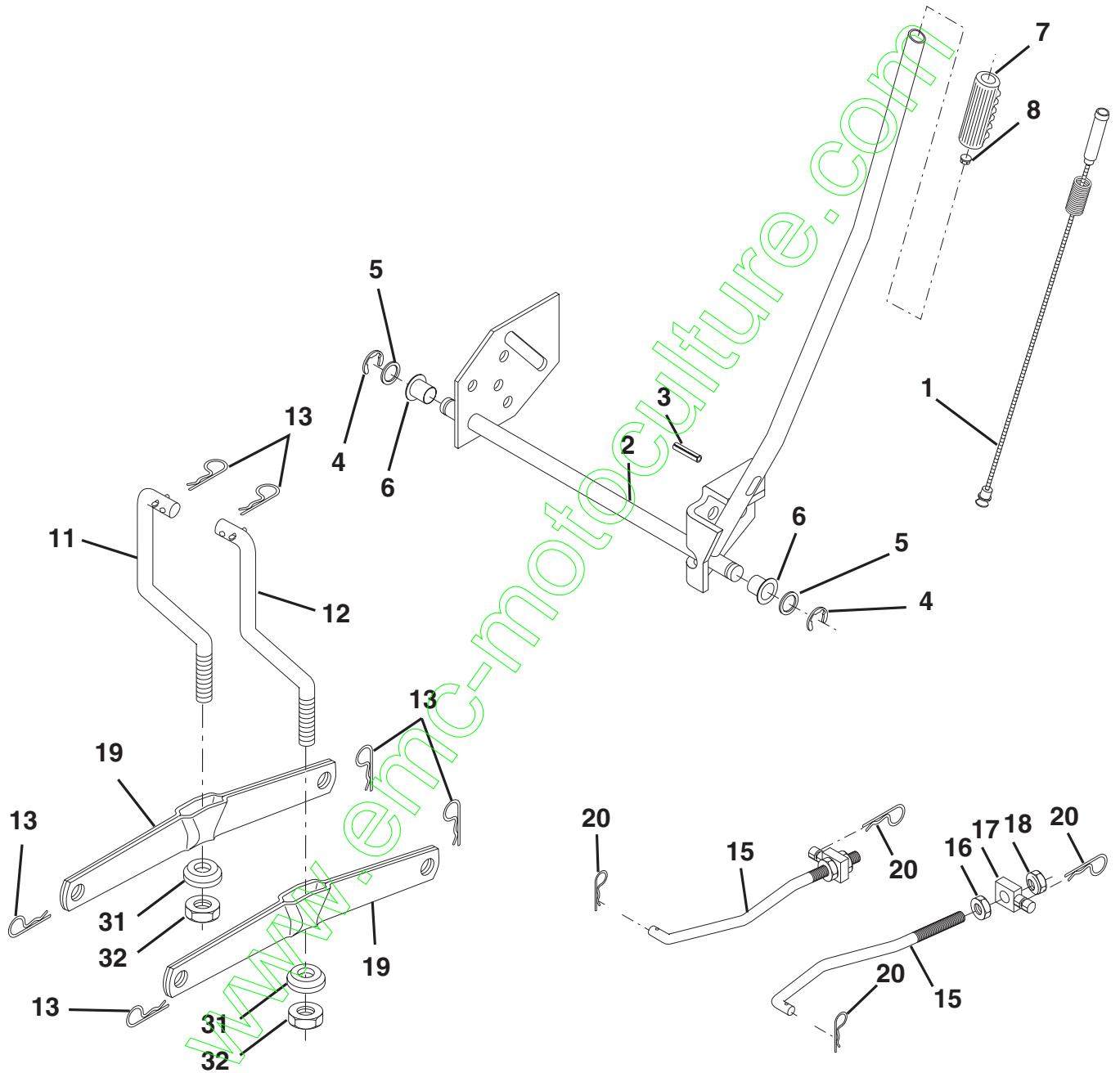

REPAIR PARTS

TRACTOR - MODEL NO. BL15542SBHK (BL155H42SBA), PRODUCT NO. 964 77 16-00
MOWER LIFT

KEY NO.	PART NO.	DESCRIPTION
1	532 15 94-60	Wire Asm Inner W/plunger LT
2	532 15 94-71	Shaft Asm Lift
3	532 10 57-67	Pin Groove
4	812 00 00-02	E Ring #5133-62
5	819 21 16-21	Washer PLTD 21/32 X 1 X 21ga
6	532 12 01-83	Bearing Nylon Blk 629 Id
7	532 10 94-13	Grip Handle Bicycle
8	532 12 45-26	Button Plunger Black
11	532 13 98-65	Link Lift LH
12	532 13 98-66	Link Lift RH
13	532 12 46-70	Retainer Spring
15	532 17 32-88	Link Front
16	873 35 08-00	Nut Jam Hex 1/2-13 Unc
17	532 17 56-89	Trunnion
18	873 80 08-00	Nut Lock W/Wsh 1/2-13 Unc
19	532 13 98-68	Arm Suspension Rear
20	532 16 35-52	Spring, Retainer
31	532 16 98-65	Bearing Pvt. Lift
32	873 54 06-00	Nut Crownlock 3/8-24

NOTE: All component dimensions given in U.S. inches
1 inch = 25.4 mm

TRACTOR - MODEL NO. BL15542SBHK (BL155H42SBA), PRODUCT NO. 964 77 16-00 SCHEMATIC

