

**ILLUSTRATED PARTS BREAKDOWN**

**BERNARD**

**16.5 HP LAWN TRACTOR**

**MODEL NO. BL16542STH (BL165T42STHA)**

**954 5671-54**

[www.emc-motoculture.com](http://www.emc-motoculture.com)

# REPAIR PARTS

TRACTOR--MODEL NUMBER BL16542STH(BL165T42STHA) PRODUCT NO.954 5671-54  
ELECTRICAL

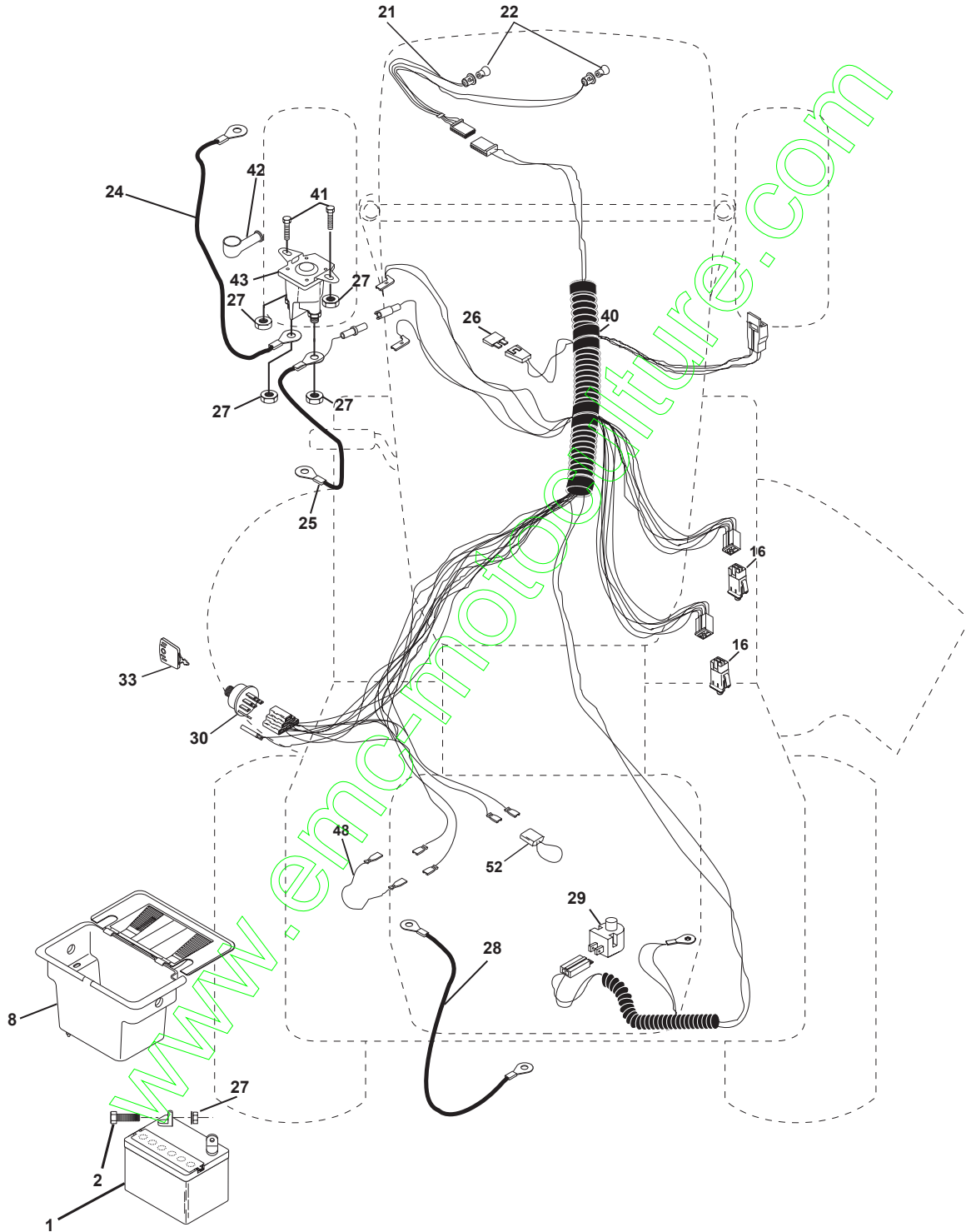

# REPAIR PARTS

TRACTOR--MODEL NUMBER BL16542STH (BL165T42STHA) PRODUCT NO. 954 5671-54  
ELECTRICAL

KEY NO.	PART NO.	DESCRIPTION
1	144925	Battery 12 VOLT 25 AMP
2	74760412	Bolt Hex Hd 1/4-20unc x 3/4
8	156417	Case Battery
16	153664	Switch, Interlock Push-In
21	166181	Harness Asm Light W/4152j
22	4152J	Bulb Light #1156
24	108423X	Cable Battery 6 Ga 16" red
25	146147	Cable Battery 6 Ga w/16 wire red
26	175158	Fuse 20 AMP
27	73510400	Nut Keps Hex 1/4-20 Unc
28	4207J	Cable Ground 6 Ga 12" black
29	121305X	Switch Plunger Nc Gray
30	175566	Switch Ign
33	140401	Key Ign
40	170217	Harness Ign Man Cl Am Hm 97
41	71110408	Bolt Blk. Fin Hex 1/4-20 Unc x 1/2
42	131563	Cover Terminal Red
43	175141	Solenoid
48	140844	Adapter Ammeter Rectangular
52	141940	Protection Wire Loop

**NOTE:** All component dimensions given in U.S. inches  
1 inch = 25.4 mm

# REPAIR PARTS

TRACTOR--MODEL NUMBER BL16542STH (BL165T42STHA) PRODUCT NO. 954 5671-54  
CHASSIS AND ENCLOSURES

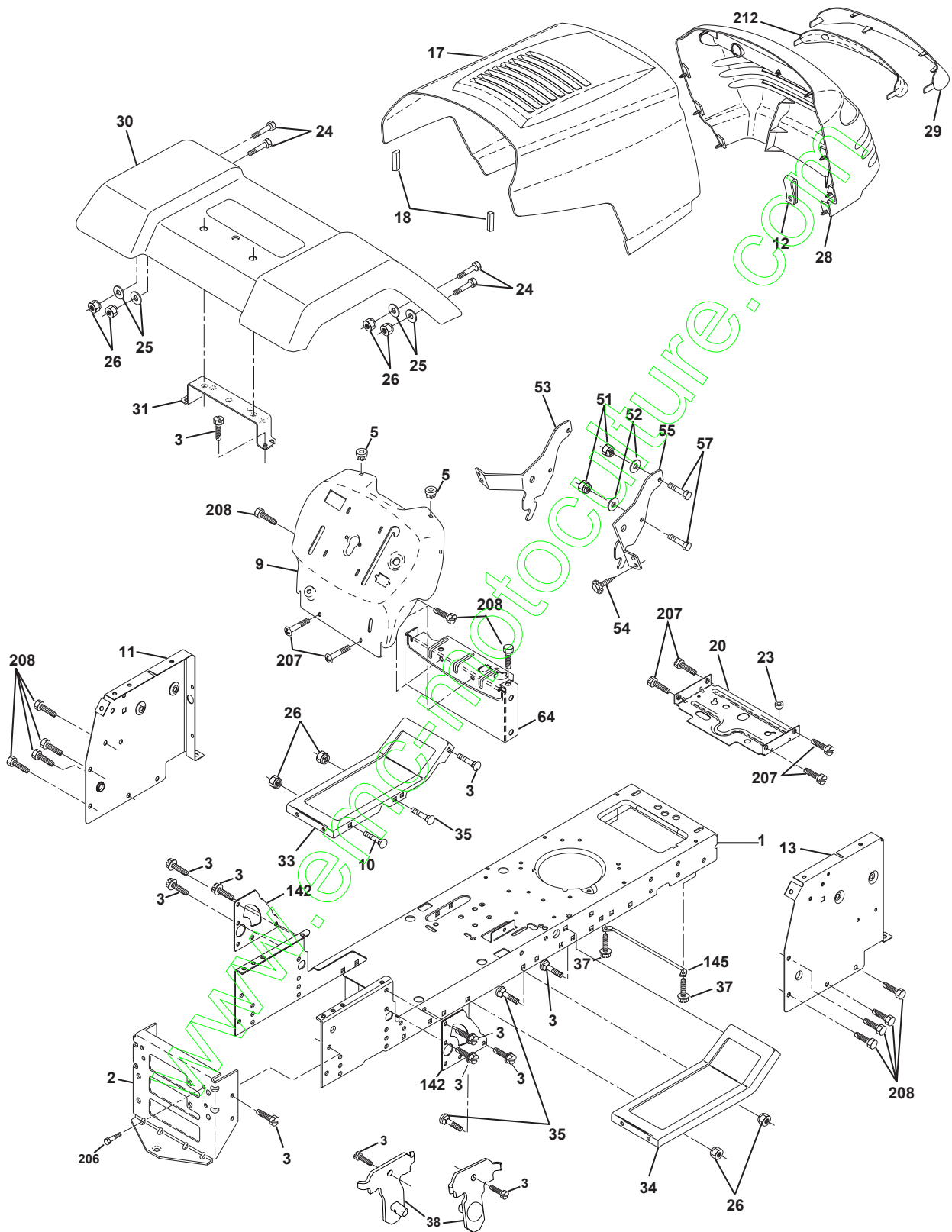

# REPAIR PARTS

TRACTOR--MODEL NUMBER BL16542STH (BL165T42STHA) PRODUCT NO. 954 5671-54  
CHASSIS AND ENCLOSURES

KEY NO.	PART NO.	DESCRIPTION
1	169830	Chassis
2	169061	Drawbar
3	17060612	Screw, 3/8-16 x 3/4
5	155272	Bumper Hood/Dash
9	168336X010	Dash
10	72140608	Bolt, Carriage 3/8-16 x 3/4
11	155927	Panel, Dash, L.H.
12	145660	Clip Tinnerman Grille P/L
13	172107X010	Panel, Dash, R.H.
17	159639X421	Hood Assembly
18	126938X	Bumper Hood
20	156437	Plate Mtg Battery Fuel Tank
23	124028X	Bushing Snap Nyl Blk Fuel Line
24	74780616	Bolt Fin Hex 3/8-16 Unc x 1 Gr 5
25	19131312	Washer 13/32 x 13/16 x 12 Gauge
26	73800600	Nut
28	170473X428	Grille/Lens Asm
29	170472X599	Lens, P/L Euro Smooth
30	169468X421	Fend/Ftrest Pnt STLT N HLD
31	136619	Bracket, Fender
33	145244X418	Footrest Pnt LH
34	145243X418	Footrest Pnt RH
35	72110606	Bolt Rdhd Sht Sqnk 3/8-16 x 3/4
37	17490508	Screw Thdrol 5/16-18 x 1/2
38	169834	Bracket Asm Pivot Mower Rear
51	73800400	Nut Lock w/Insert 1/4-20 UNC
52	19091416	Washer 9/32 x 7/8 x 16 Ga.
53	144697	Bracket Grille LH
54	161464	Screw Hex Wshd 8-18 x 7/8
55	144696	Bracket Grille RH
57	74780412	Bolt, Fin Hex 1/4-20 UNC x .75
64	154798	Dash Lower STLT
142	165867	Plate Reinforcement STLT
145	156524	Rod Pivot Chassis/Hood
206	170165	Bolt Shoulder 5/16-18 TT
207	17670508	Screw Thdrol 5/16-18 x 1/2
208	17670608	Screw Thdrol 3/8-16 x 1/2
212	174503	Insert Lens
--	5479J	Plug, Button

**NOTE:** All component dimensions given in U.S. inches  
1 inch = 25.4 mm

# REPAIR PARTS

TRACTOR--MODEL NUMBER BL16542STH (BL165T42STHA) PRODUCT NO. 954 5671-54  
GROUND DRIVE

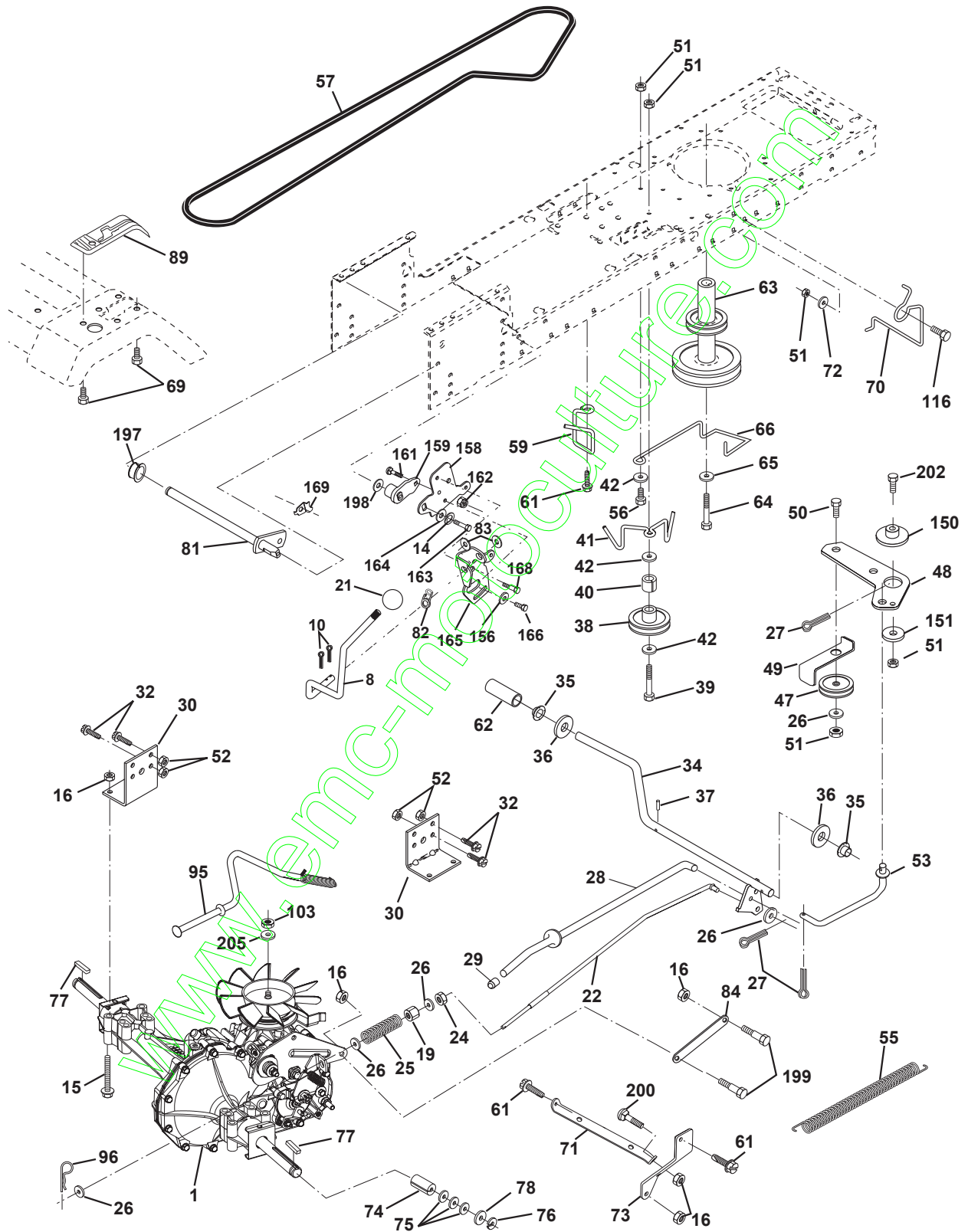

# REPAIR PARTS

TRACTOR--MODEL NUMBER BL16542STH (BL165T42STHA) PRODUCT NO. 954 5671-54  
GROUND DRIVE

KEY NO.	PART NO.	DESCRIPTION	KEY NO.	PART NO.	DESCRIPTION
1	-----	Transaxle Hydro Gear Model 322-0510 (Order parts from the transaxle manufacturer)	65	10040700	Washer
8	165619	Rod, Shift	66	154778	Keeper, Belt Engine Hydro
10	76020416	Pin, Cotter 1/8 x 1	69	142432	Screw Hex Wsh Hi-Lo 1/4-1/2 Unc
14	10040400	Washer Lock 1/4	70	134683	Guide, Belt, Mower Drive RH
15	74490544	Bolt Hex Flghd 5/16-18 Gr. 5	71	169183	Strap, Torque, Lh
16	73800500	Nut, Lock Hex w/lins 5/16-18 UNC	72	19132012	Washer 13/32 x 1-1/4 x 12 Ga.
19	73800600	Nut, Lock Hex w/Wsh 3/8-16 UNC	73	169182	Strap, Torque, Rh
21	106933X	Knob Rd. 1/2-13 Plstc. Thds. Blk.	74	137057	Spacer, Axle
22	169498	Rod, Brake	75	121749X	Washer 25/32 x 1-1/4 x 16 Ga.
24	73350600	Nut	76	12000001	Ring, E
25	106888X	Spring, Rod, Brake	77	123583X	Key, Square
26	19131316	Washer 13/32 x 13/16 x 16 Ga.	78	121748X	Washer 25/32 x 1-5/8 x 16 Ga.
27	76020412	Pin, Cotter 1/8 x 3/4	81	165596	Shaft Asm Cross
28	145204	Rod, Parking Brake	82	123782X	Spring, Torsion
29	71673	Cap, Parking Brake	83	19171216	Washer 17/32 x 3/4 x 16 Ga.
30	174973	Bracket, Transmission	84	169843	Link Transaxle
32	74760512	Bolt Hex 5/16-18 UNC x 3/4	89	169373X428	Console, Shift
34	155071	Shaft, Foot Pedal	95	170201	Control Asm Bypass Hydro
35	120183X	Bearing, Nylon	96	4497H	Spring, Retainer 1"
36	19211616	Washer	103	73940800	Nut, Hex Jam Toplock 1/2-20 UNF
37	1572H	Pin, Roll	116	72110610	Bolt Rdhd Sq Neck 3/8-16 x 1-1/4
38	131494	Pulley, Idler, Flat	150	165850	Bushing Bellcrank Grd Drive
39	74760644	Bolt	151	19133210	Washer 13/32 x 2 x 10
40	4470J	Spacer, Split	156	166002	Washer 5/16 x 1.0 x 1.25
41	165838	Keeper, Belt, Idler	158	165589	Bracket Shift Mount
42	19131312	Washer 13/32 x 13/16 x 12 Ga.	159	165494	Hub Tapered Flange Shift
47	127783	Pulley, Idler, V-Belt	161	72140406	Bolt Rdhd Sqnk 1/4-20 x 3/4 Gr. 5
48	154407	Bellcrank Clutch Grnd Drustl	162	73680400	Nut Crownlock 1/4-20 Unc
49	123205X	Retainer, Belt	163	74780416	Bolt Hex Fin 1/4-20 x 1
50	74760624	Bolt	164	19091010	Washer 5/8 x .281 x 10 Ga.
51	73680600	Nut	165	165623	Bracket Pivot Lever
52	73680500	Nut Crownlock 5/16-28	166	166880	Screw 5/16 x 1.0 x .125
53	105710X	Link, Clutch	168	165492	Bolt Shoulder 5/16-18 x .561
55	105709X	Spring, Return, Clutch	169	165580	Plate Fastener Cross Shaft
56	74760620	Bolt, Hex 3/8-16 UNC x 1-1/4	197	169613	Nyliner Snap-in 5/8" ID
57	140294	V-Belt, Drive	198	169593	Washer Nyl 7/8ID x .105"HYD
59	169691	Keeper, Belt, Center	199	169612	Bolt Shoulder 5/16-18 Unc
61	17060612	Screw, 3/8-16 x 3/4	200	72140508	Bolt Rdhd Sqnk 5/16-18 Unc x 1
62	8883R	Cover, Pedal	202	72110612	Bolt Car SH 3/8-16 x 1-1/2 Gr 5
63	140186	Pulley, Engine	205	19171616	Washer 17/32 x 1 x 16 Ga
64	71170764	Bolt Hex 7/16 x 4 Gr. 5			

**NOTE:** All component dimensions given in U.S. inches  
1 inch = 25.4 mm

# REPAIR PARTS

TRACTOR--MODEL NUMBER BL16542STH (BL165T42STHA) PRODUCT NO. 954 5671-54  
STEERING ASSEMBLY

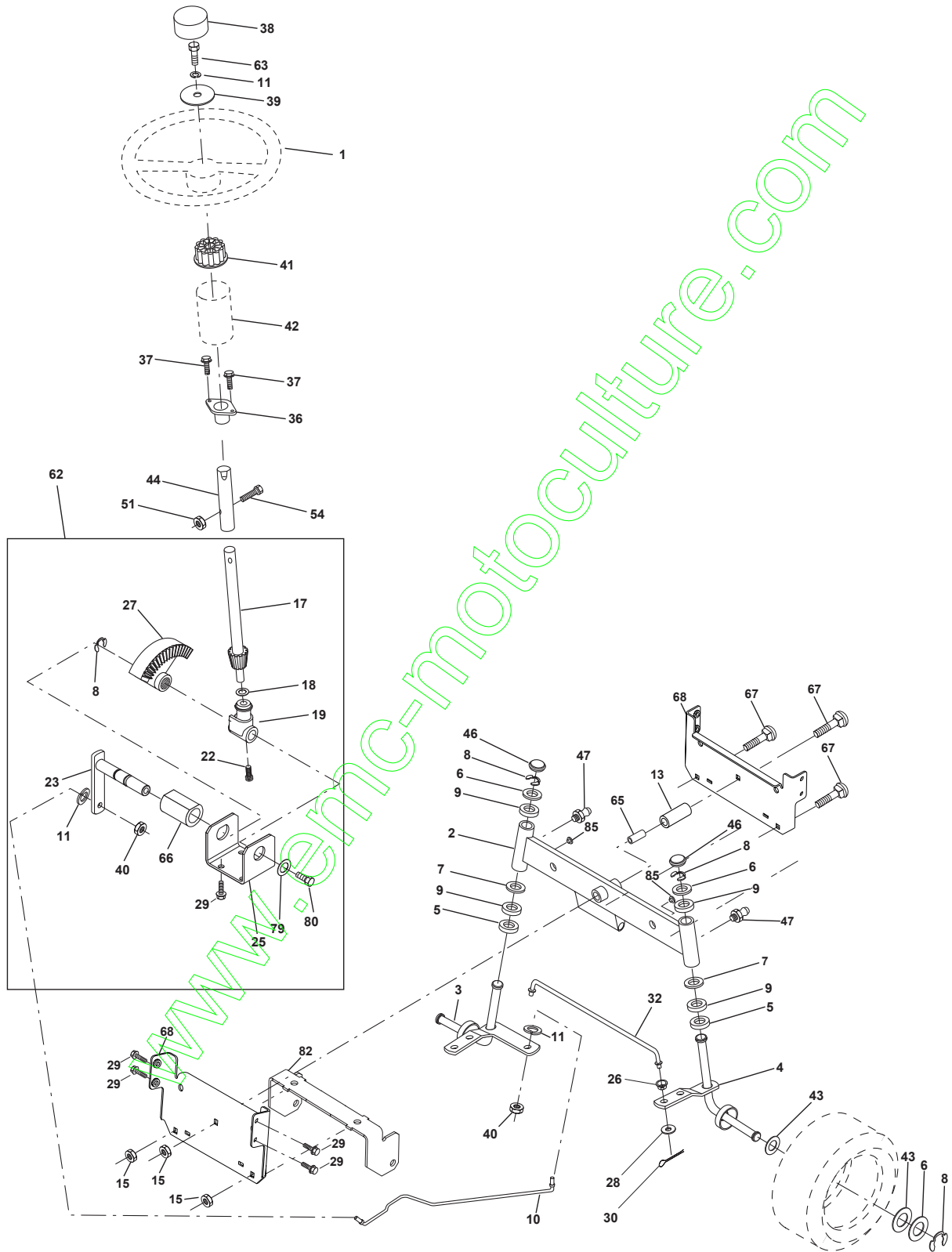



# REPAIR PARTS

TRACTOR--MODEL NUMBER BL16542STH (BL165T42STHA) PRODUCT NO. 954 5671-54  
STEERING ASSEMBLY

KEY NO.	PART NO.	DESCRIPTION
1	139768	Steering Wheel
2	154427	Axle Assembly STMP Dropped STL
3	169840	Spindle Assembly, L.H.
4	169839	Spindle Assembly, R.H.
5	6266H	Bearing, Race, Thrust, Hardened
6	121748X	Washer 25/32 x 1-5/8 x 16 Gauge
7	19272016	Washer 27/32 x 1-1/4 x 16 Gauge
8	12000029	Ring, Klip
9	3366R	Bearing, Steering Column
10	169832	Draglink Extended Stamped
11	10040600	Washer, Lock
13	136518	Spacer Brg Axle Front
15	145212	Hex Flange Lock
17	156546	Shaft Assembly, Steering
18	57079	Washer, Thrust .515 x .750 x .033
19	160395	Support, Shaft
22	165857	Screw, Hex Wsh Hd Torx
23	165851	Pittman Shaft Assembly
25	154406	Bracket, Steering
26	126847X	Bushing, Link, Drag
27	136874	Gear, Sector
28	19131416	Washer 13/32 x 7/8 x 16 Gauge
29	17060612	Screw, 3/8-16 x 3/4
30	76020412	Pin
32	130465	Rod, Tie
36	155099	Bushing, Steering
37	152927	Screw
38	140175	Insert, Steering Wheel
39	19133812	Washer 13/32 x 2-3/8 x 12 Gauge
40	7810H	Nut Lock Center 3/8-24Unf
41	100711L	Adaptor, Steering Wheel
42	145054X428	Boot, Steering Shaft
43	121749X	Washer 25/32 x 1-1/4 x 16 Gauge
44	153720	Extension Shaft Steering LR.LT
46	121232X	Cap, Spindle
47	6855M	Fitting, Grease
51	73800500	Nut Lock Hex w/Ins. 5/16-18 UNC
54	74780520	Bolt Fin Hex 5/16-18 UNC x 1-1/4
62	167902	Kit Steering Asm Service
63	74780616	Bolt, Fin Hex 3/8-16 UNC x 1 Gr 5
65	160367	Spacer Brace Axle
66	154404	Bearing Arm Pittman
67	72140618	Bolt Rdhd Sq 3/8-16 x 2-1/4
68	169827	Axle, Brace
79	19132012	Washer 13/32 x 1-1/4 x 12 Ga.
80	74950612	Bolt Hex Nylon 3/8-16 x 3/4
82	169835	Bracket Susp Chassis Front
85	133835	Fastner Christmas Tree

**NOTE:** All component dimensions given in U.S. inches  
1 inch = 25.4 mm

# REPAIR PARTS

TRACTOR -- MODEL NUMBER BL16542STH (BL165T42STHA) PRODUCT NO. 954 5671-54  
ENGINE

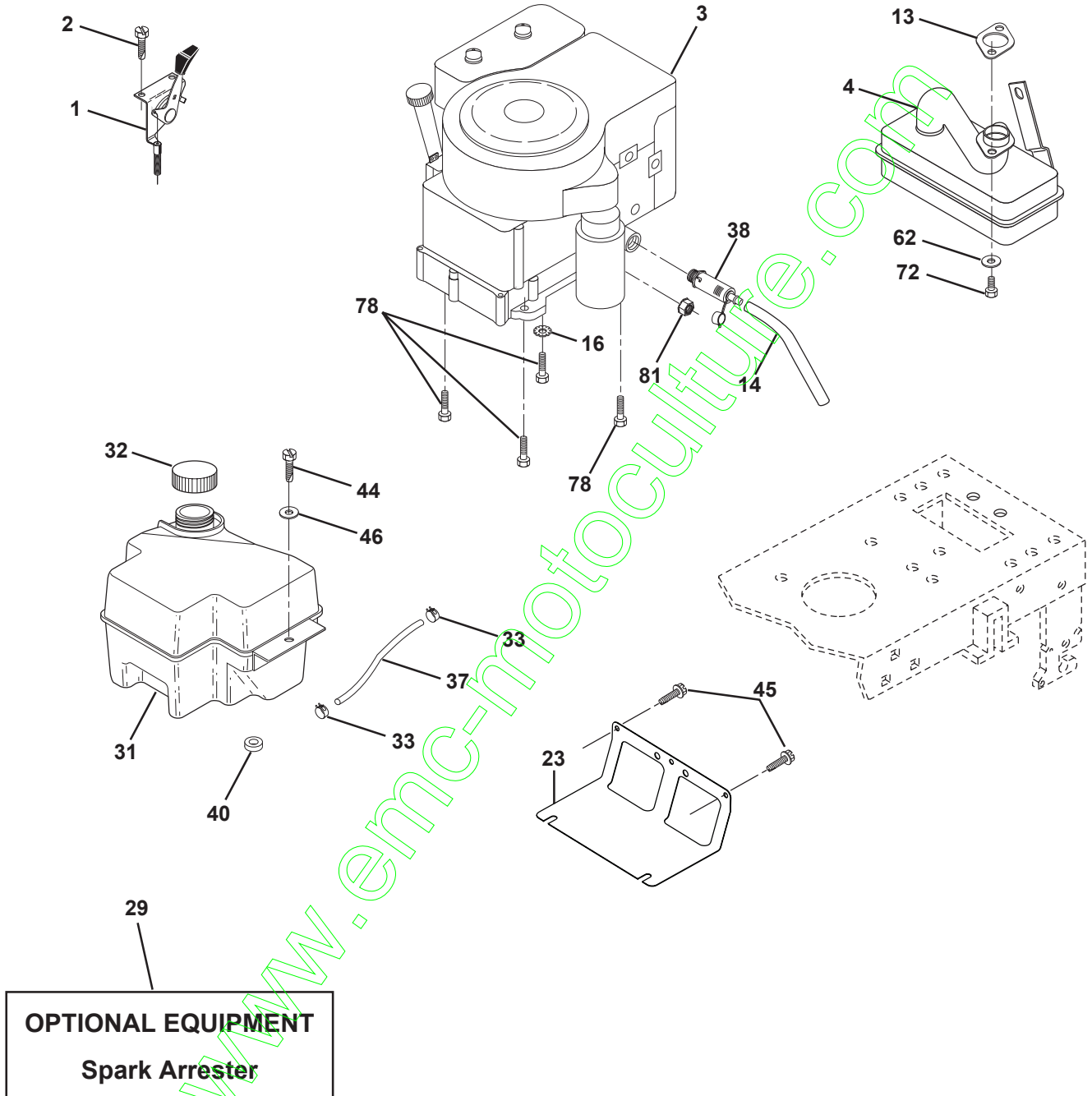

# REPAIR PARTS

TRACTOR--MODEL NUMBER BL16542STH (BL165T42STHA) PRODUCT NO. 954 5671-54  
ENGINE

KEY NO.	PART NO.	DESCRIPTION
1	170551	Control Throt /Ch Lh
2	17720410	Screw Hex Thd Cut 1/4-20x5/8 T
3	-----	Engine Tec. Model OHV165 (Order parts from engine manufacturer)
4	137351	Muffler Exhaust Tec.
13	149272	Gasket
14	148456	Tube Drain Oil Easy
16	11050600	Washer Lock Ext Tooth 3/8
23	169837	Shield Browning/Debris Guard
29	137180	Arrestor Spark
31	174642	Tank Fuel
32	140527	Cap Asm Fuel
33	123487X	Clamp Hose Blk
37	137040	Line Fuel 20"
38	148315	Plug Drain Oil Easy
38	-----	Plug Oil Drain (Order From Engine Manufacturer)
40	124028X	Bushing Snap Nyl Blk Fuel Line
44	17670412	Screw Hexwsh Thdrol 1/4-20x3/4
45	17000612	Screw Hexwsh Thdr 3/8-16 x 3/4
46	19091416	Washer 9/32 X 7/8 X 16ga
62	10040500	Washer Lock Hvy Hlcl Spr 5/16
66	127951	Stop Throttle
72	123528X	Bolt Hex HD Philips
78	17060620	Screw 3/8-16x1-1/4
81	73510400	Nut Keps Hex 1/4-20 Unc

**NOTE:** All component dimensions given in U.S. inches  
1 inch = 25.4 mm

# REPAIR PARTS

TRACTOR -- MODEL NUMBER BL16542STH (BL165T42STHA) PRODUCT NO. 954 5671-54  
SEAT

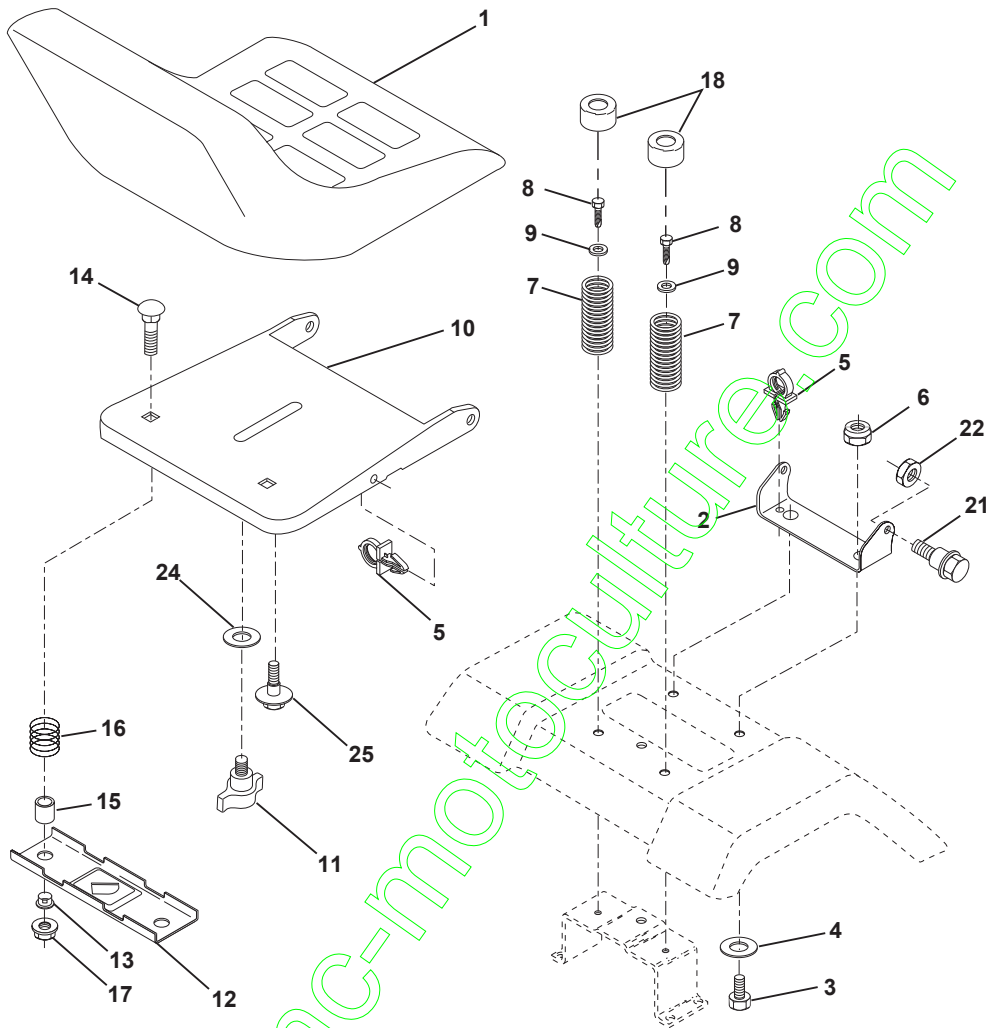

KEY NO.	PART NO.	DESCRIPTION
1	175390	Seat
2	140551	Bracket Pnt Pivot Seat (blk )
3	71110616	Bolt Fin Hex 3/8-16unc X 1
4	19131610	Washer 13/32 X 3/4 X 10 Ga
5	145006	Clip Push In Hinged
6	73800600	Nut Hex Lock w/Ins 3/8-16 Unc
7	124181X	Spring Seat Cprsn 2 250 Blk Zi
8	17000616	Screw Thdrol 3/8-16 X 1-1/2
9	19131614	Washer 13/32 X 1 X 14 Ga
10	174894	Pan Pnt Seat (blk )
11	166369	Knob Seat Adj Wingnut
12	121246X	Bracket Pnt Mounting Switch

KEY NO.	PART NO.	DESCRIPTION
13	121248X	Bushing Snap Blk Nyl 50 Id
14	72050412	Bolt Rdhd Sht Nk 1/4-20x1-1/2
15	121249X	Spacer Split 28 X 88 Zinc
16	123740X	Spring Cprsn 1 27 Blk Pnt
17	123976X	Nut Lock 1/4 Lge Flg Gr 5 Zinc
21	171852	Bolt Shoulder 5/16-18 Unc-2A
22	73800500	Nut Hex Lock w/Ins 5/16-18
24	19171912	Washer 17/32 X 1-3/16 X 12 Ga.
25	127018X	Bolt Shoulder 5/16-18 X 62

**NOTE:** All component dimensions given in U.S. inches  
1 inch = 25.4 mm

# REPAIR PARTS

TRACTOR--MODEL NUMBER BL16542STH (BL165T42STHA) PRODUCT NO. 954 5671-54  
DECALS

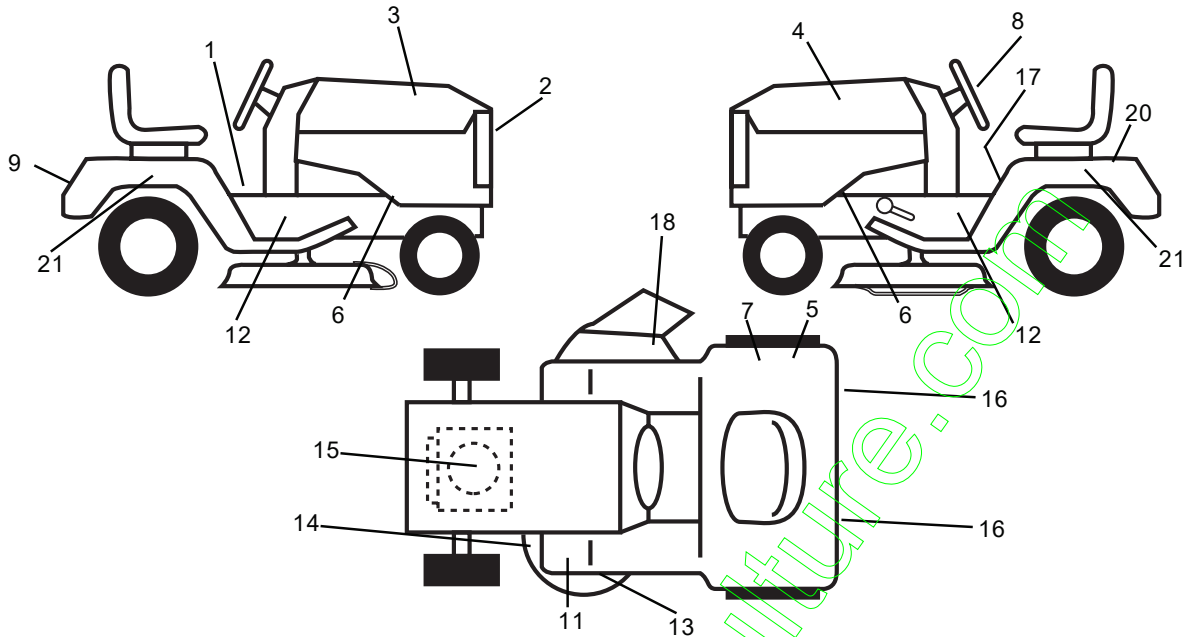

KEY NO.	PART NO.	DESCRIPTION
1	140837	Decal, Saddle Parking Brake
2	166287	Decal, Lens Logo
3	175946	Decal, Hood, R.H.
4	175947	Decal, Hood, L.H.
5	126187X	Decal, DBA
6	159736	Decal, Chassis Hot Muffler
7	145437	Decal Europe Stand CE
8	166285	Decal Inst Strg Whl
9	166708	Decal, Fender, Logo
11	159737	Decal Brake/Clutch
12	157637	Decal, Chassis 42/Hyd
13	134999	Decal, Enviro Deck

KEY NO.	PART NO.	DESCRIPTION
14	160396	Decal, V-Belt Schematic
15	64-1733-29	Decal, Engine
16	106202X	Reflector Tail Light
17	145498	Decal Read Owners Manual
18	145494	Decal Mower Cutfinger Symbol
20	145005	Decal Battery Dngr/Psn Eng
21	171300	Decal, Fender Auto Radius
--	138311	Decal, Lift Handle
--	169210	Decal By Pass Lt Hydro
--	1571199X428	Pad Footrest LH STLT
--	162598	Decal, Drawbar Load Limit
--	176071	Manual Oper Euro

## WHEELS & TIRES

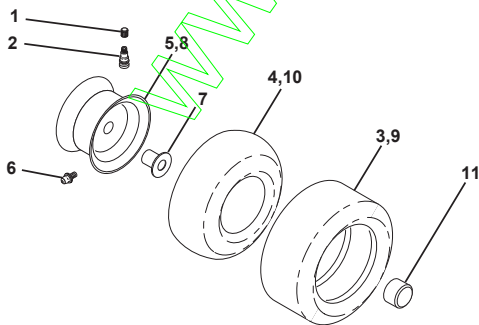

KEY NO.	PART NO.	DESCRIPTION
1	59192	Cap Value Tire
2	65139	Stem Value
3	106222X	Tire F Ts 15 X 6 0 - 6 Service
4	59904	Tube Inner Front #35060
5	106732X421	Rim Asm 6" front Service
6	278H	Fitting Grease
7	9040H	Bearing Flange
8	106108X421	Rim Asm 8" rear Service
9	106268X	Tire R Ts 18x9 5-8 Service
10	7152J	Tube Rear 9 5 X 8 Service
11	104757X428	Cap Axle Blk 1 50 X 1 00
--	144334	Sealant, Tire (10 oz. tube)

**NOTE:** All component dimensions given in U.S. inches 1 inch = 25.4 mm

# REPAIR PARTS

TRACTOR--MODEL NUMBER BL16542STH(BL165T42STHA) PRODUCT NO.9545671-54  
LIFT ASSEMBLY

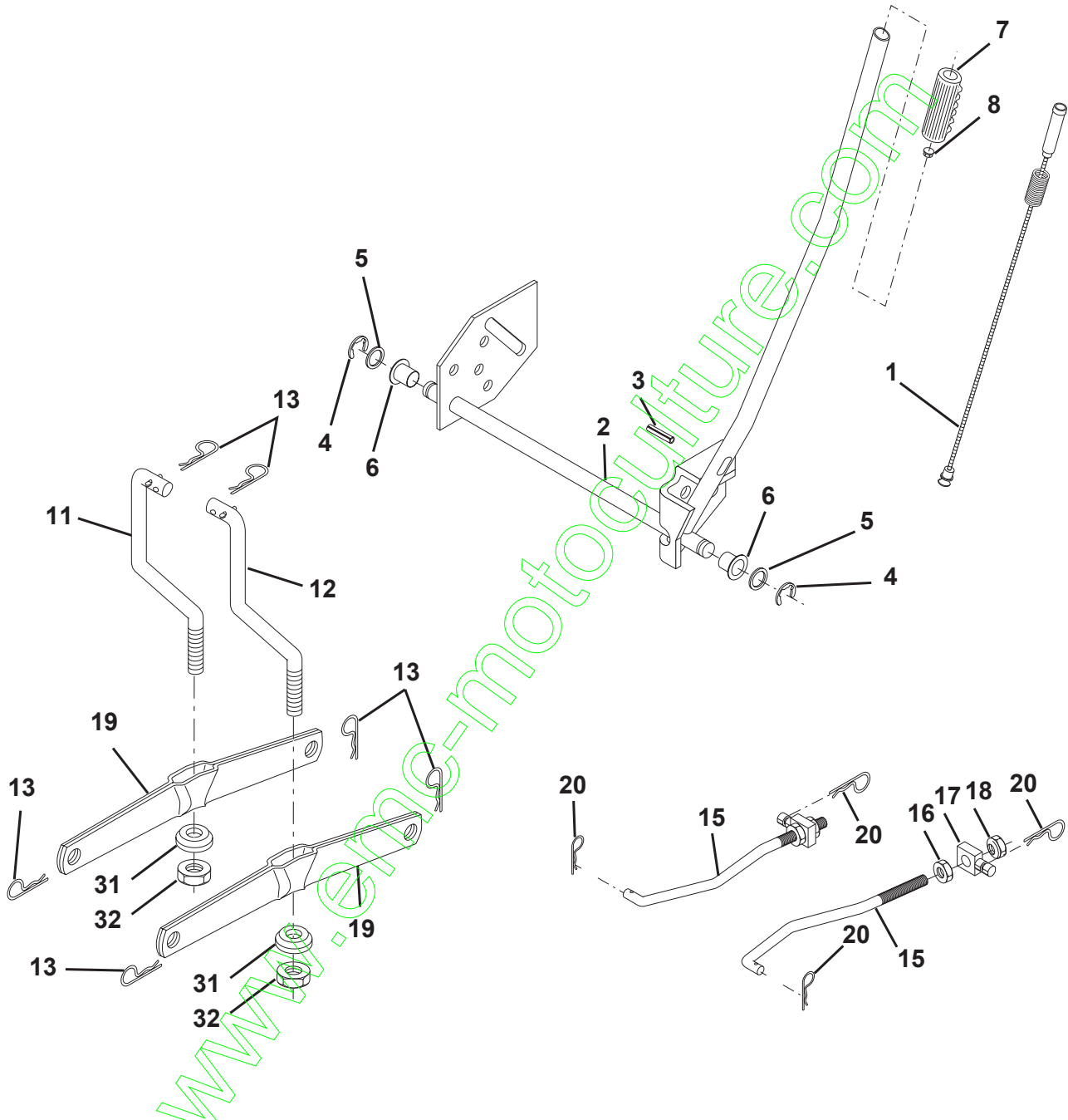

# REPAIR PARTS

TRACTOR--MODEL NUMBER BL16542STH (BL165T42STHA) PRODUCT NO. 954 5671-54  
LIFT ASSEMBLY

KEY NO.	PART NO.	DESCRIPTION
1	159460	Washer Asm Inner Spring W/Plunger
2	159471	Shaft Asm. Lift
3	105767X	Pin Groove
4	12000002	E Ring #5133-62
5	19211621	Washer 21/32 x 1 x 21 Ga.
6	120183X	Bearing Nylong
7	109413X	Grip Handle
8	124526X	Button Plunger
11	139865	Link Asm Lift L.H.
12	139866	Link Asm Lift R.H.
13	4939M	Retainer Spring
15	173288	Link Front
16	73350800	Nut Jam Hex 1/2-13 Unc
17	130171	Trunnion Blk Zinc
18	73800800	Nut Lock W/wsh 1/2-13 Unc
19	139868	Arm Suspension Mower
20	163552	Retainer Spring
31	169865	Bearing, Pvt. Lift.
32	73540600	Nut Crownlock 3/8-24

**NOTE:** All component dimensions given in U.S. inches  
1 inch = 25.4 mm

# REPAIR PARTS

TRACTOR--MODEL NUMBER BL16542STH (BL165T42STHA) PRODUCT NO. 954 5671-54  
MOWER DECK

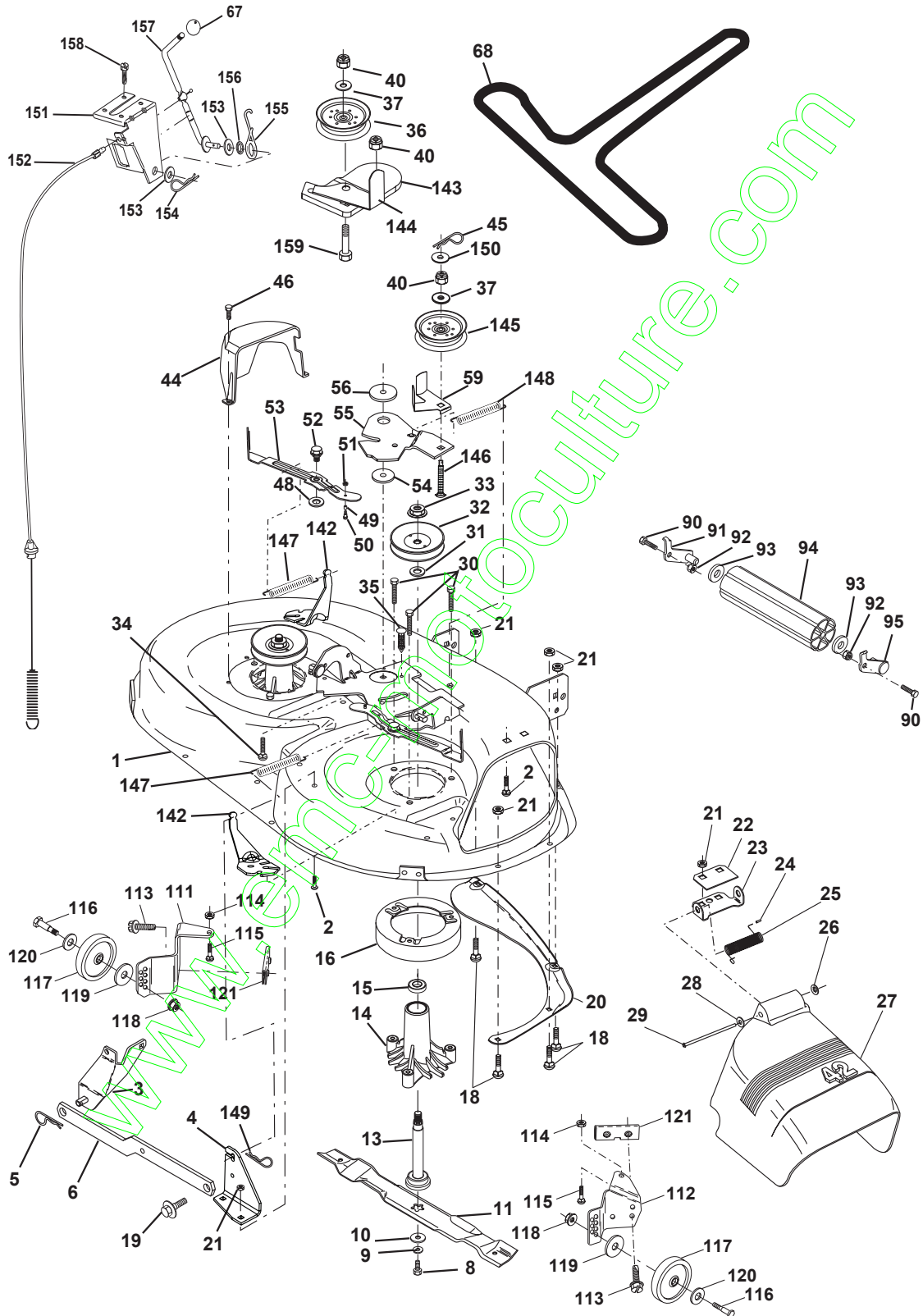



# REPAIR PARTS

TRACTOR--MODEL NUMBER BL16542STH (BL165T42STHA) PRODUCT NO. 954 5671-54  
MOWER DECK

KEY NO.	PART NO.	DESCRIPTION	KEY NO.	PART NO.	DESCRIPTION
1	165892	Mower Deck Assembly, 42"	56	165723	Spacer, Retainer
2	72140506	Bolt	59	141043	Guard, TUV Idler
3	138017	Bracket Assembly, Sway Bar, Front	67	106932X	Knob, round
4	165460	Bracket Sway Bar 38/42" Deck	68	144959	V-Belt
5	4939M	Retainer Spring	90	74760616	Bolt Fin Hex 3/8-16 Unc x 1
6	130832	Arm, Suspension, Rear	91	132274	Bracket Asm Noseroller Lh
8	850857	Bolt, Hex 3/8-24 x 1.25 Gr. 8	92	73800600	Nut
9	10030600	Washer, Lock	93	19171416	Washer 17/32 x 7/8 x 16 Ga
10	140296	Washer, Hardened	94	132264	Roller Nose 38&42
11	138498	Blade, High Perf	95	132273	Bracket Asm Nose Roller RH
13	137645	Shaft Assembly, Mandrel, Vented (Includes Key Number 12)	111	155197	Bracket, Gauge, Wheel L.H.
14	128774	Housing, Mandrel, Vented	112	155198	Bracket, Gauge, Wheel R.H.
15	110485X	Bearing, Ball, Mandrel	113	17060514	Screw 5/16-18
16	140329	Stripper, Vented Mower Deck	114	73510500	Nut, Keps 5/16-18 UNC
18	72140505	Bolt, Carriage 5/16-18 x 5/8	115	72110504	Bolt, Carriage 5/16 UNC x 1/2
19	132827	Bolt, Shoulder	116	4898H	Bolt, Shoulder
20	159770	Baffle, Vortex	117	105455X	Wheel, Gauge
21	73680500	Nut Crownlock 5/16-18 UNC	118	73930600	Nut, Centerlock 3/8-16
22	134753	Stiffener Bracket	119	19121414	Washer 3/8 x 7/8 x 14 Gauge
23	131267	Bracket, Deflector	120	19171512	Washer 17/32 x 15/16 x 12 Ga.
24	105304X	Cap, Sleeve	121	143723	Bracket
25	123713X	Spring, Torsion, Deflector	142	165890	Arm Spring Brake Mower
26	110452X	Nut, Push	143	157109	Bracket Arm Idler 42"
27	130968X428	Shield, Deflector	144	158634	Keeper Belt 42" Clutch Cable
28	19111016	Washer 11/32 x 5/8 x 16 Ga.	145	165888	Pulley Idler Flat
29	131491	Rod, Hinge	146	171977	Bolt Carriage Idler
30	157722	Screw Thdrol Washer Head	147	131335	Spring Extension
31	129963	Washer, Spacer	148	169022	Spring Return Idler
32	153535	Pulley, Mandrel	149	165898	Retainer Spring Yellow Zinc
33	137266	Nut, Toplock, Flanged	150	19091216	Washer 9/32 x 3/4 x 16 Ga.
34	72110614	Bolt	151	169670	Bracket Clutch
35	133835	Fastner, Christmas Tree	152	169676	Cable Clutch 42 In
36	131494	Pulley, Idler, Flat	153	169674	Washer Flat 3/8" Type B
37	19131316	Washer 13/32 x 13/16 x 16 Gauge	154	169675	Spring Retainer
40	73680600	Nut Crownlock 3/8-16 UNC	155	169671	Spring Retention Lever
44	140088	Guard, Mandrel, L.H.	156	169672	Spacer
45	4497H	Retainer	157	169669	Rod Clutch
46	137729	Screw, Thd. Roll 1/4-20 x 5/8	158	17720410	Screw Hex Thd Cut 1/4-20 x 5/8
48	133944	Washer, Hardened	159	72140614	Bolt Rdhd Sqn 3/8-16 Unc x 1-3/4
49	174284	Roller Assembly, Cam Follower	--	130794	Mandrel Assembly (Includes Key Numbers 8-10, 12-15, 31 and 32)
50	131340	Bolt, Shoulder #10-24 Grade 5	--	171491	Mower Deck, complete
51	69180	Locknut			
52	139888	Bolt, Shoulder 5/16-18 UNC			
53	131845	Arm Assembly, Pad, Brake			
54	133943	Washer, Hardened			
55	155046	Arm, Idler			

**NOTE:** All component dimensions given in U. S. inches  
1 inch = 25/4 mm

**TRACTOR -- MODEL NUMBER BL16542STH (BL165T42STHA) PRODUCT NO. 954 5671-54 SCHEMATIC**

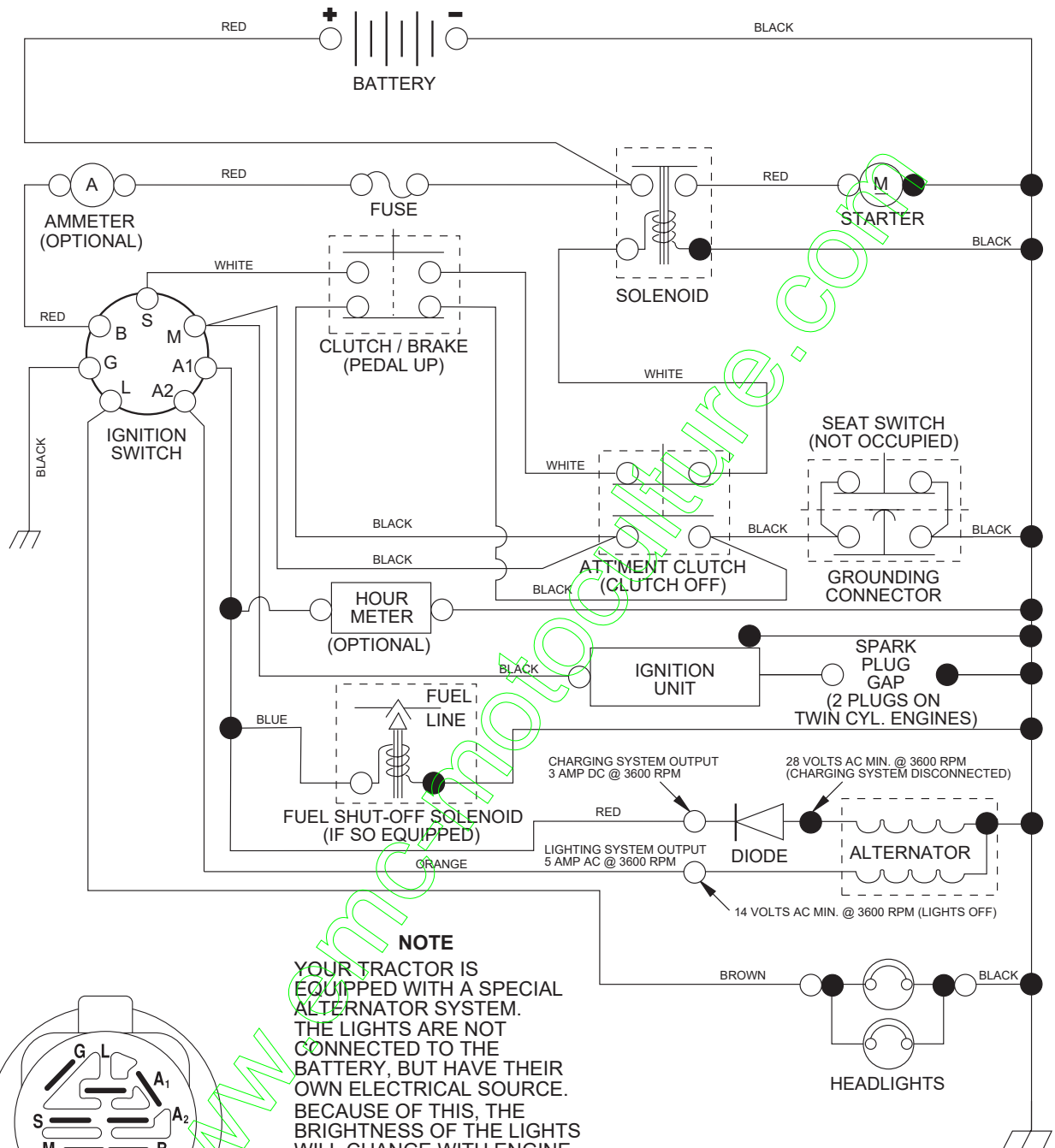

**NOTE**

YOUR TRACTOR IS EQUIPPED WITH A SPECIAL ALTERNATOR SYSTEM. THE LIGHTS ARE NOT CONNECTED TO THE BATTERY, BUT HAVE THEIR OWN ELECTRICAL SOURCE. BECAUSE OF THIS, THE BRIGHTNESS OF THE LIGHTS WILL CHANGE WITH ENGINE SPEED. AT IDLE THE LIGHTS WILL DIM. AS THE ENGINE IS SPEEDED UP, THE LIGHTS WILL BECOME THEIR BRIGHTEST.

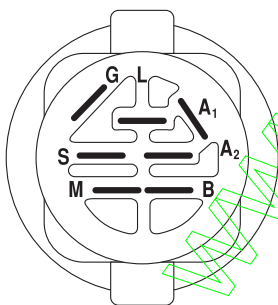

**IGNITION SWITCH**

POSITION	CIRCUIT	"MAKE"
OFF	M+G+A1	NONE
RUN/LIGHT	B+A1	A2+L
RUN	B+A1	NONE
START	B + S + A1	NONE

NON-REMOVABLE CONNECTIONS

REMOVABLE CONNECTIONS

**WIRING INSULATED CLIPS**

**NOTE:** IF WIRING INSULATED CLIPS WERE REMOVED FOR SERVICING OF UNIT, THEY SHOULD BE REPLACED TO PROPERLY SECURE YOUR WIRING.