

REPAIR PARTS MANUAL

39" - 12 H.P. LAWN TRACTOR

MODEL C3560-420

ONE YEAR LIMITED WARRANTY

For one (1) year from date of purchase by the first consumer for residential use (thirty (30) days commercial use), NOMA Outdoor Products Incorporated warrants that it will replace free of charge, including labor, any original part of any NOMA Outdoor Products Incorporated product found to be defective by any authorized Service Dealer or the factory, except the battery which is warranted for ninety (90) days from date of purchase.

This warranty does not cover engine, transmission, transaxle or differential (these items are covered by their manufacturer's own warranty). This warranty does not cover parts that have failed due to normal wear or parts that have failed subject to misuse or abuse. Transportation of the unit or part to and from an authorized Service Dealer or factory is the responsibility of the owner.

A step by step explanation as to what procedure should be followed for this warranty is:

1. If a part becomes defective, contact the store where the unit was purchased for the name and address of the authorized Service Dealer nearest to you.
2. If you cannot locate an authorized Service Dealer, write Service Department of NOMA Outdoor Products Incorporated for the name and address of the authorized Service Dealer in your area or call the Service Department at 1-901-422-1690.
3. Return the defective product, along with proof of purchase to such authorized Service Dealer for replacement of any defective part where covered by this warranty.

There is no other express warranty. Implied warranties, including those of merchantability and fitness for a particular purpose are limited to one (1) year from date of purchase. Liability for incidental or consequential damages are excluded.

Some states do not allow limitations on how long an implied warranty lasts, so the above limitation may not apply to you. Some states do not allow the exclusion of incidental or consequential damages, so the above exclusion may not apply to you. This warranty gives you specific legal rights, and you may have other rights which vary from state to state.

NOMA Outdoor Products Incorporated

Caller 8000

Jackson, TN 38308-8000

UNIT PARTS AND SERVICE

Fill in and mail the registration card packed with the unit. For service other than covered in this manual, contact an authorized service dealer. When ordering repair parts, always give the following information: 1. The Part Name; 2. The Part Number; 3. The Quantity desired; 4. The Full (eight digit) Model Number of the unit. The model number will be found on a plate attached to the unit.

Look for this symbol.



It means - **ATTENTION! BECOME ALERT! A HAZARD TO OPERATOR, BYSTANDER, PROPERTY OR EQUIPMENT MAY EXIST.**

NOMA Outdoor Products Incorporated

Caller 8000

Jackson, TN 38308-8000

39" LAWN TRACTOR MODEL C3560-420

CHASSIS & HOOD ASSEMBLY

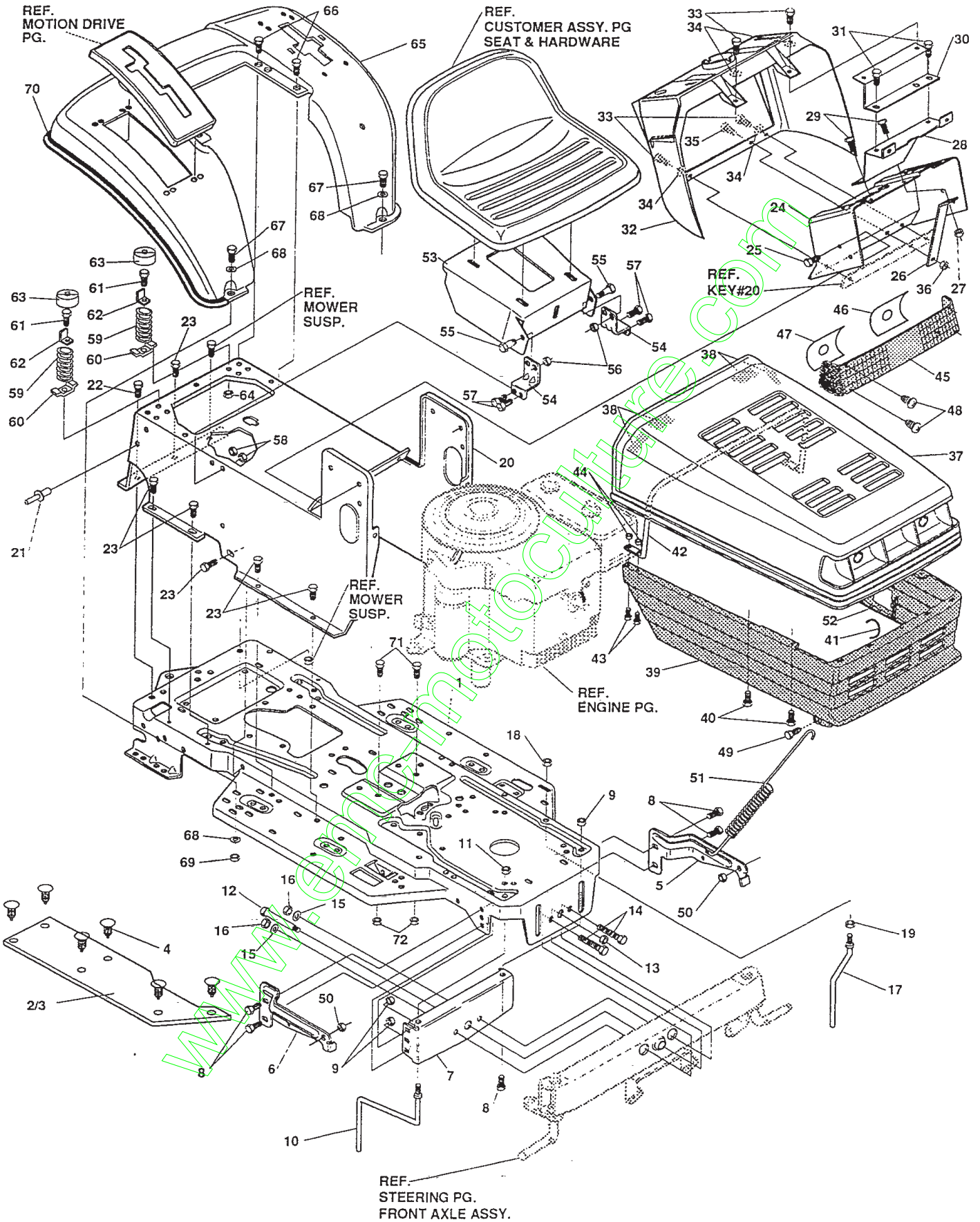

NOTE: ALWAYS USE ORIGINAL EQUIPMENT PARTS. Use of service/replacement parts other than original equipment parts may void your warranty.

ALL UNNUMBERED ITEMS ARE INTERCHANGABLE WITH OPPOSITE SIDE

323011A

39" LAWN TRACTOR MODEL C3560-420

key#	part#	description	qty.
1	321708-860	FRAME,LF MAIN P920/F4360	1
2	310005	FOOTPAD,LH	1
3	310006	FOOTPAD,RH	1
4	309235	FASTENER, RATCHET	12
5	302915-853	BRACKET,GRILLE LH	1
6	302914-853	BRACKET,GRILLE RH	1
7	313541-853	BRACKET, FRONT AXLE	1
8	• 56030	SCREW, 5/16-18X.75WDFLLK	5
9	• 55273	NUT, 5/16-18 HXWDFLLK	5
10	300440	GUIDE, BELT, RIDER	1
11	• 1498	NUT, 5/16-18 REGHEXCTRLK	1
12	308207	BOLT, 625X2.180 HSH 1/2-13NC	1
13	• 309008	NUT, 1/2-13 REGHCTRLK	1
14	• 122207	SCREW, 3/8-16X3.00 HHC	2
15	2483	WASHER, .39IDX1.25DX.07 BELLVIL	2
16	• 1499	NUT, 3/8-16 REGHXCTRLK	2
17	300635	GUIDE,SHORT BELT RIDER 15"WH	1
18	• 124824	NUT, 5/16-18 HEXJAM	1
19	• 271190	NUT, 3/8-16 HEXKEPS	1
20	309660-860	CONSOLE W/O TOP SHIFT	1
21	46763	RIVET, POP .187DIA X .450	1
22	• 35497	SCREW, 5/16-18X .50 WAHHTAP	1
23	• 995346	SCREW, 1/4-20X .50 WAHHTAP	12
24	58312-853	SUPPORT, DASH	1
25	• 300303	SCREW, .25X.75X.75HHWAPLASTITE	2
26	300201-853	BRACE, DASH SUPT LOWER	1
27	• 1502	NUT, 1/4-20 REGHEXCTRLK	1
28	302530-853	BRKT, GAS TANK	1
29	• 995346	SCREW, 1/4-20X .50 WAHHTAP	2
30	302530-853	BRACE, DASH SUPT UPPER	1
31	995346	SCREW, 1/4-20X .50 WAHHTAP	2
32	305428	DASH, W/O GRAPHIC,SUS	1
33	• 995346	SCREW, 1/4-20X .50 WAHHTAP	4
34	316868	WASHER,SHOULDER NYLON .255X.46	4
35	• 44811	SCREW, 1/4-20X .75 HXWATAP	1
36	• 1502	NUT, 1/4-20 REGHEXCTRLK	1
37	307058-660	HOOD, PLASTIC	1
38	318197	PAD,ADHESIVE 1.00 X	4
39	303037	GRILL,LWR GPWR	1
40	• 300302	SCREW, #10 X .50 HHTAPPST	4
41	310203	CLIP,HOG RING C-SHAPED	1
42	301425	BRACE,HOOD SUPPORT	1
43	• 301542	SCREW, 10-24X1.00HWATAPBLKPHOS	4
44	• 271166	NUT, #10-24 HEXKEPS	4
45	302333	LENS, SMOKED W/TAB	1
46	301541	FOIL, REFLECTOR LENS H-11 LH	1
47	301540	FOIL, REFLECTOR LENS H-11 RH	1
48	• 57796	SCREW, #6 X .50 PLASTITE	4
49	56676	BOLT, .375X .580 HSH 5/16-18	2
50	• 1498	NUT, 5/16-18 REGHEXCTRLK	2
51	57478	SPRING, HOOD LATCH	2
52	301452	FOIL, HEAT REFLECTOR	1
53	58221-860	PLATE, SEAT	1
54	53746-860	BRACKET, F-5 SEAT SUPPORT	1
55	20507	BOLT, .437X .156 HSH 5/16-18	2
56	• 1498	NUT, 5/16-18 REGHEXCTRLK	2
57	• 48901	SCREW, 5/16-18X .63 HHC	4
58	• 1498	NUT, 5/16-18 REGHEXCTRLK	4
59	49335	SPRING,SEAT 2.63LG,1.49OD	2
60	53744	CLAMP,SPRING 1.17"ID	2
61	• 44811	SCREW, 1/4-20X .75 HXWATAP	2
62	300292	STOP, SEAT	2
63	56907	COVER,SEAT SPRING 1.5IDX1.0	2
64	1502	NUT, 1/4-20 REGHEXCTRLK	2
65	308653-860	FENDER F-5 SUS LF FDR SHIFT	1
66	• 995346	SCREW, 1/4-20X .50 WAHHTAP	4
67	• 122017	SCREW, 5/16-18X1.00 HHC	2
68	• 446363	WASHER, FLAT .375X .88X.082	4
69	• 1498	NUT, 5/16-18 REGHEXCTRLK	2
70	55021	TRIM,STRIP,BLACK	77.5"
71	180079	SCREW,5/16-18X1.00 HHC	2
72	1498	NUT,5/16-16 REGHEXCTRLK	2
73	322932	DANISH OPERATOR MANUAL (NOT ILLUSTRATED)	1
74	322987	ENGLISH PARTS MANUAL (NOT ILLUSTRATED)	1

• Indicates STANDARD HARDWARE ITEMS.

39" LAWN TRACTOR MODEL C3560-420

MOWER SUSPENSION ASSEMBLY

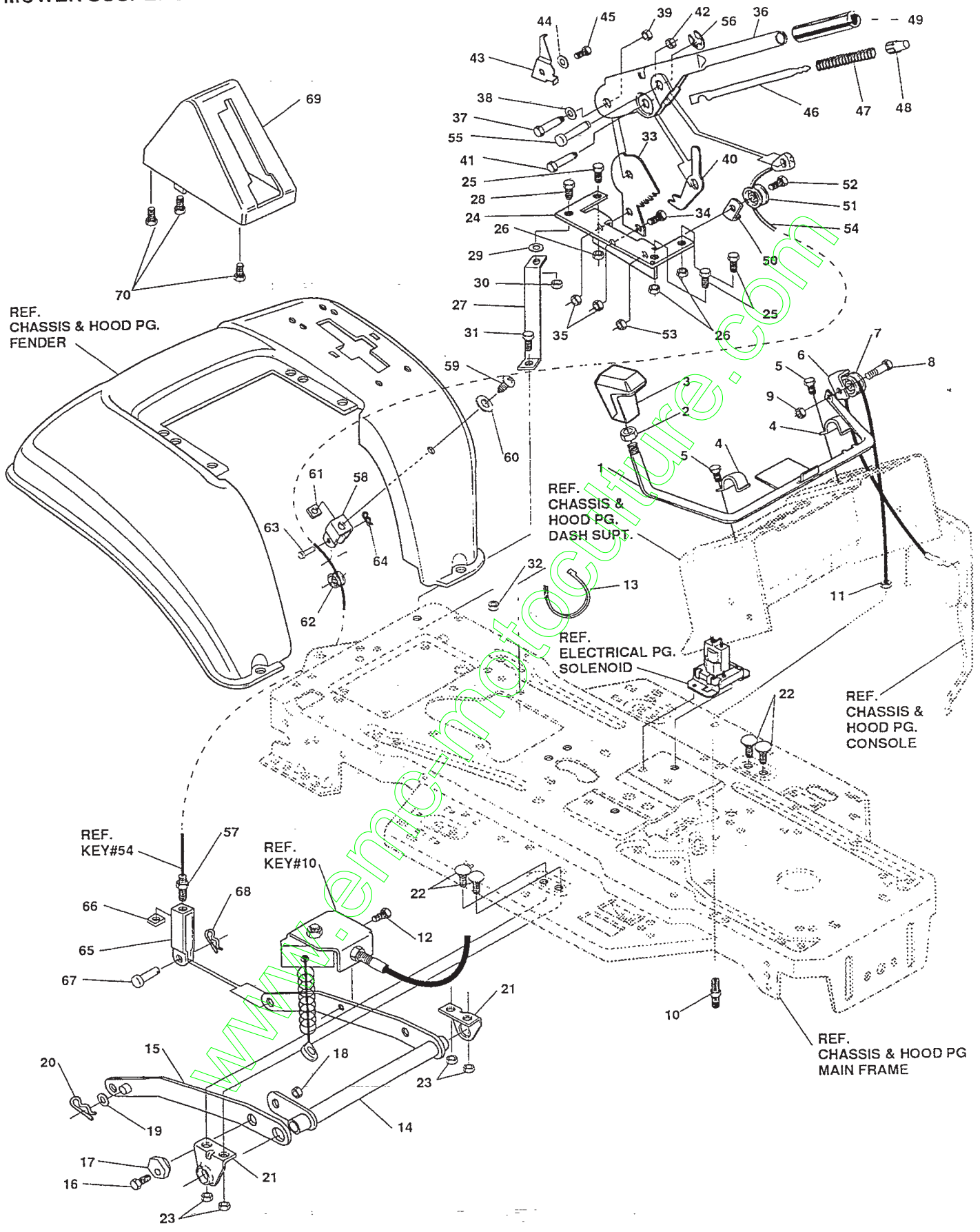

NOTE: ALWAYS USE ORIGINAL EQUIPMENT PARTS. Use of service/replacement parts other than original equipment parts may void your warranty.

ALL UNNUMBERED ITEMS ARE INTERCHANGABLE WITH OPPOSITE SIDE

315559E

39" LAWN TRACTOR MODEL C3560-420

key#	part#	description	qty.
1	303044-853	CLUTCH HANDLE	1
2	◇120238	NUT, 1/2-13 HEXJAM	1
3	304438-653	KNOB,SHIFT NOMA 1/2-13	1
4	58307-953	CLIP, RETAINING BRKT	2
5	◇995338	SCREW, 1/4-20X .63 WAHHTAP	2
6	52456-953	BRKT,CABLE RETAINER	1
7	39298	PULLEY, .906X.305 NYLON	1
8	57322	BOLT, .375X .375 HSSH 1/4-20	1
9	◇1502	NUT, 1/4-20 REGHEXCTRLK	1
10	301491	ASSY,CL. CABLE GEN PWR 39SDSUS	1
11	◇120613	NUT, 1/4-28 HJAM	1
12	◇35498	SCREW, 5/16-18X .75 WAHHTAP	1
13	57444	TIE, CABLE BLACK NYLON 5.62	1
14	300158-853 -	ASSY,REAR LIFT	1
15	300169-853 -	ASSY.LINK,RIGHT SIDE	1
16	◇180079 -	SCREW, 5/16-18X1.00 HHC	1
17	58247	ADJUSTING NUT	1
18	◇1498	NUT, 5/16-18 REGHEXCTRLK	1
19	◇417098	WASHER, FLAT .531X1.06X.095	2
20	8260	PIN, HAIR .091 DIAX1.66LG	2
21	58248-853	BRKT,REAR,HANG,SUSP.	2
22	126211	BOLT, 5/16-18X .63 CARR	4
23	◇1498	NUT, 5/16-18 REGHEXCTRLK	4
24	58333	BRACKET,HGT/ADJUST SUPPORT	1
25	180077	SCREW, 5/16-18X .75 HHC	3
26	◇1498	NUT, 5/16-18 REGHEXCTRLK	3
27	300336-860	BRACE, FENDER F-5 SUS	1
28	◇180079	SCREW, 5/16-18X1.00 HHC	1
29	◇45602	WASHER, FLAT .333X .87X.119	1
30	◇1498	NUT, 5/16-18 REGHEXCTRLK	1
31	◇180079	SCREW, 5/16-18X1.00 HHC	1
32	◇1498	NUT, 5/16-18 REGHEXCTRLK	1
33	301238	QUADRANT,HEIGHT ADJUST	1
34	◇180077	SCREW, 5/16-18X .75 HHC	2
35	◇1498	NUT, 5/16-18 REGHEXCTRLK	2
36	322292-853 -	HANDLE,LIFT SHORT	1
37	300171	BOLT, .500X .270 HSSH 5/16-18	1
38	996418	WASHER, FLAT .506X .75X.024	1
39	◇44108	NUT, 5/16-18 HWDFLCTRLK	1
40	301239	PAWL, HEIGHT ADJUST	1
41	300171	BOLT, .500X .270 HSSH 5/16-18	1
42	◇44108	NUT, 5/16-18 HWDFLCTRLK	1
43	300782-953 9435	POINTER 9435	1
44	138479	WASHER, EXLK .195X.41X.03	1
45	◇35287	SCREW, #8-32X .38 HHWATAP	1
46	303027	ROD,ACTUATOR-SHORT	1
47	58326	SPRING, HEIGHT ADJUST	1
48	58325	KNOB, HGT ADJ PUSH BUTTON	1
49	58329	GRIP, .750 OD W/ HOLE	1
50	58335-953 -	BRKT, CABLE RETAIN	1
51	39298	PULLEY, .906X.305 NYLON	1
52	58336	BOLT, .375X .375 HSSH 1/4-20	1
53	◇1502	NUT, 1/4-20 REGHEXCTRLK	1
54	300341	CABLE, LIFT 21.70 F-5 20X8-8	1
55	300310	PIN,CLEVIS .310DIA+.475LG	1
56	300311	RING, RET E .31X.24	1
57	◇120375	NUT, 1/4-20 REGHEX	1
58	300298-953 -	CLEVIS	1
59	◇439455	SCREW, 5/16-18X .56PHPNMA BKPH	1
60	301551	WASHER,.344IDX1.50DX.09 CU BPH	1
61	◇120373	NUT, 5/16-18 SQ	1
62	39298	PULLEY, .906X.305 NYLON	1
63	300317	PIN, CLEVIS .38 DIAX1.00 LG	1
64	8260	PIN, HAIR .091 DIAX1.66LG	1
65	300703-953 -	CLEVIS, LIFT CABLE	1
66	◇120372	NUT, 1/4-20 REGSQ	1
67	39522	PIN, CLEVIS .312 X .812	1
68	121222	PIN, COTTER .090/.086X.75LG	1
69	300335	LIFT COVER-39" F5	1
70	◇300340	SCREW, #10 X .75 HHPLAST	3

◇STANDARD HARDWARE ITEMS

STEERING ASSEMBLY

REF. CUSTOMER ASSY. PG. STEERING WHEEL & HARDWARE

CHASSIS AND HOOD PAGE Ref. Dash

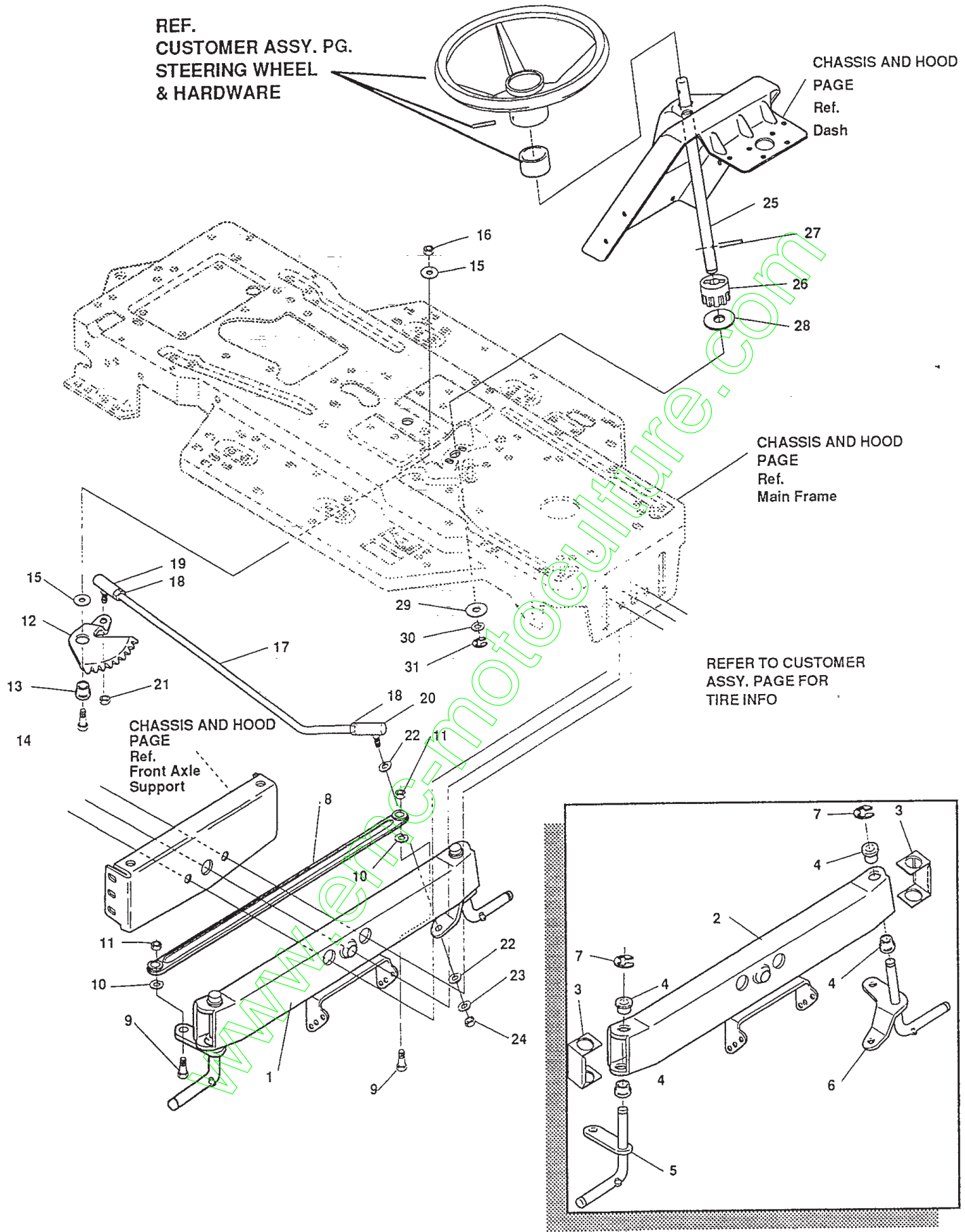

CHASSIS AND HOOD PAGE Ref. Main Frame

REFER TO CUSTOMER ASSY. PAGE FOR TIRE INFO

CHASSIS AND HOOD PAGE Ref. Front Axle Support

ALL UNNUMBERED ITEMS ARE INTERCHANGABLE WITH OPPOSITE SIDE

NOTE: ALWAYS USE ORIGINAL EQUIPMENT PARTS. Use of service/replacement parts other than original equipment parts may void your warranty.

39" LAWN TRACTOR MODEL C3560-420

key#	part#	description	qty.
1.		ASSY,AXLE FRONT	1
2.	300272	ASSY FRONT AXLE SUSPENDED	1
3.	53373	AXLE COVER	2
4.	52407	SPINDLE BEARING	4
5.	302926	ASSY,SPINDLE RH	1
6.	315886	ASSY,SPINDLE LH	1
7.	36625	RING, RETEX .57X.05TRU5133-75	2
8.	304590	TIE ROD ASSY 19.81LG W-SECTION	1
9.	• 180128	SCREW, 3/8-16X1.75 HHC	2
10.	120382	WASHER, REGSPTLK.393X.68X.10	2
11.	• 1499	NUT, 3/8-16 REGHXCTRLK	2
12.	58289	SECTOR, STEERING LF	1
13.	52406	BRNG,FL ECC.510IDX .998ODX .56	1
14.	• 180177	SCREW, 1/2-13X1.50 HHC	1
15.	22265	WASHER, FLAT .515X1.38X.119PL	2
16.	• 1500	NUT, 1/2-13 REGHCTRLK	1
17.	58291	STEERING LINK	1
18.	• 124925	NUT, 3/8-24 REGHEXJAM	2
19.	57158	BALL JOINT 3/8 THD SHORT STUD	1
20.	21275	BALL JOINT 3/8 TH'D LONG STUD	1
21.	• 46692	NUT, 3/8-24 WDFLHLK WHIZ	1
22.	996416	WASHER, FLAT .391X1.00X.125	2
23.	120382	WASHER, REGSPTLK.393X.68X.10	1
24.	• 120369	NUT, 3/8-24 REGHEX	1
25.	58243	SHAFT, STEERING LF	1
26.	58244	PINION, STEERING LF	1
27.	58274	PIN,DOWEL .2500 OD+1.75LG PL	1
28.	301410	BRNG, FL .752IDX1.061ODX .24	1
29.	301398	WASHER, FORMED1.135X1.53X.12	1
30.	21682	WASHER, FLAT .765X1.25X.042	1
31.	36625	RING, RETEX .57X.05TRU5133-75	1

* ORDER INDIVIDUAL PARTS.
 • STANDARD HARDWARE ITEMS

www.emc-motorture.com

MOTION DRIVE ASSEMBLY

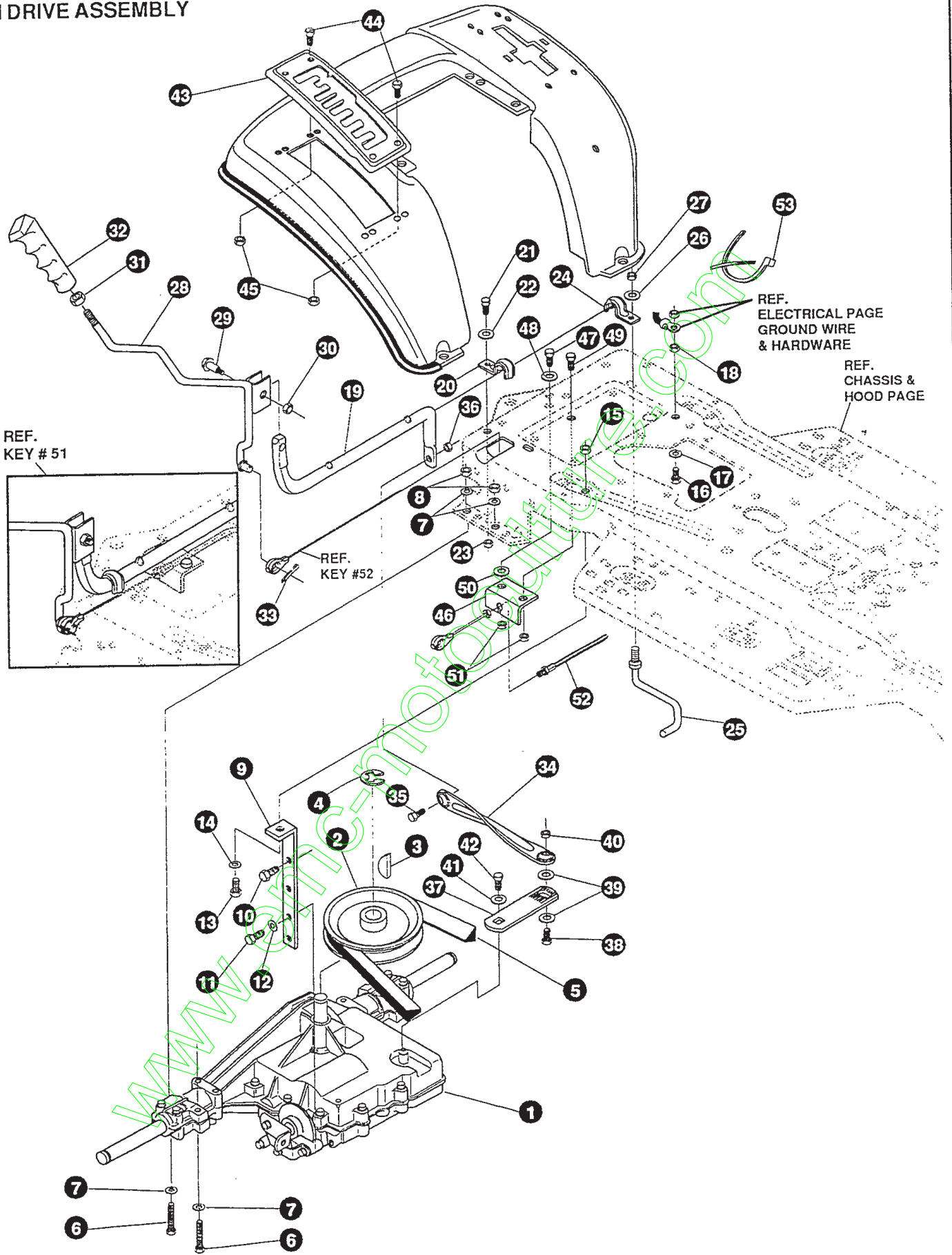

NOTE: ALWAYS USE ORIGINAL EQUIPMENT PARTS.
Use of service/replacement parts other than original equipment parts may void your warranty.

**ALL UNNUMBERED
ITEMS ARE INTERCHANGABLE
WITH OPPOSITE SIDE**

39" LAWN TRACTOR MODEL C3560-420

key#	part#	description	qty
1.	~	TRANSAXLE FOOTE 4360-6SPHD	1
2.	302745	PULLEY, IDLER V4L 6.60X	1
3.	3021	KEY, WDRF 606 .750X.187X.312	1
4.	22053	RING, RETEX .58X.035TRU5100-62	1
5.	314120 →	BELT, V 4L 87.25 4WS LF	1
6.	• 180112	SCREW, 5/16-18X2.75 HHC	4
7.	120393	WASHER, FLAT .344X .69X.065	8
8.	• 1498	NUT, 5/16-18 REGHEXCTRLK	4
9.	323471	BRACKET,STABILIZER	1
10.	• 50947	SCREW, 3/8-16X1.25 WAHHTAPBLKP	1
11.	• 35498	SCREW, 5/16-18X .75 WAHHTAP	1
12.	120638	WASHER, HVSPTLK .328X.60X.09	1
13.	• 122017	SCREW, 5/16-18X1.00 HHC	1
14.	120393	WASHER, FLAT .344X .69X.065	1
15.	• 1498	NUT, 5/16-18 REGHEXCTRLK	1
16.	• 122007	SCREW, 5/16-18X .75 HHC	1
17.	138538	WASHER, REGINTLK.320X.61X.03	1
18.	• 1498	NUT, 5/16-18 REGHEXCTRLK	1
19.	319209 →	LEVER,SHIFT-LWR,SHIFT N GO LF	1
20.	310347-853 →	CLIP-SHIFT LEVER .62 ROD	1
21.	• 180077	SCREW, 5/16-18X .75 HHC	1
22.	996416	WASHER, FLAT .391X1.00X.125	1
23.	• 1498	NUT, 5/16-18 REGHEXCTRLK	1
24.	310347-853 →	CLIP-SHIFT LEVER .62 ROD	1
25.	57259 →	GUIDE, BELT 5/16-18THD	1
26.	996416	WASHER, FLAT .391X1.00X.125	1
27.	• 1498	NUT, 5/16-18 REGHEXCTRLK	1
28.	320041-953 →	UPPER SHIFT LEVER ASM SOG	1
29.	321092 →	BOLT, .380X .570 HSSH 1/4-20	1
30.	50352	NUT, 1/4-20 WDFLLK TOPLOCK	1
31.	• 120377 →	NUT, 3/8-16 REGHX	1
32.	306689 →	HANDLE 3/8-16	1
33.	137185	PIN, COTTER .125 DIA X 1.00 LG	1
34.	314971 →	LINK TIE ROD SHIFTER 7.746C/L	1
35.	• 180124	SCREW, 3/8-16X1.25 HHC	1
36.	• 1499	NUT, 3/8-16 REGHXCTRLK	1
37.	310758-955 →	BRACKET,SHIFT 5SP SF FEN HT	1
38.	• 180124	SCREW, 3/8-16X1.25 HHC	1
39.	120394	WASHER, FLAT .406X .81X.065	2
40.	• 1499	NUT, 3/8-16 REGHXCTRLK	1
41.	57157	WASHER,.750X.250 SP-TRANSAXLE	1
42.	• 56255	SCREW, 1/4-28X .75 NYLHHCGR8	1
43.	319806-853 →	QUADRANT,SHIFT,F4360-6HD	1
44.	305850	SCREW, 1/4-20X.50PHPNTAPGR5BK	4
45.	• 1502	NUT, 1/4-20 REGHEXCTRLK	4
46.	319591-953 →	BRKT,FRAME,SHIFT N GO,ZINC PLT	1
47.	• 180022	SCREW, 1/4-20X 1.0 HHC	1
48.	120392	WASHER,FLAT .281 X 63 X.065	1
49.	57038	BOLT, 1/4-20X .63 CARR	1
50.	316080	SPACER .328 X .50 X .38	1
51.	• 1502	NUT, 1/4-20 REGHEXCTRLK	2
52.	319803 →	CABLE, SHIFT N GO	1
53.	57444	TIE, NYLON	1

~ CONTACT YOUR NEAREST FOOTE TRANSAXLE DEALER FOR PARTS AND SERVICE.
 • STANDARD HARDWARE ITEMS

MOTION DRIVE ASSEMBLY

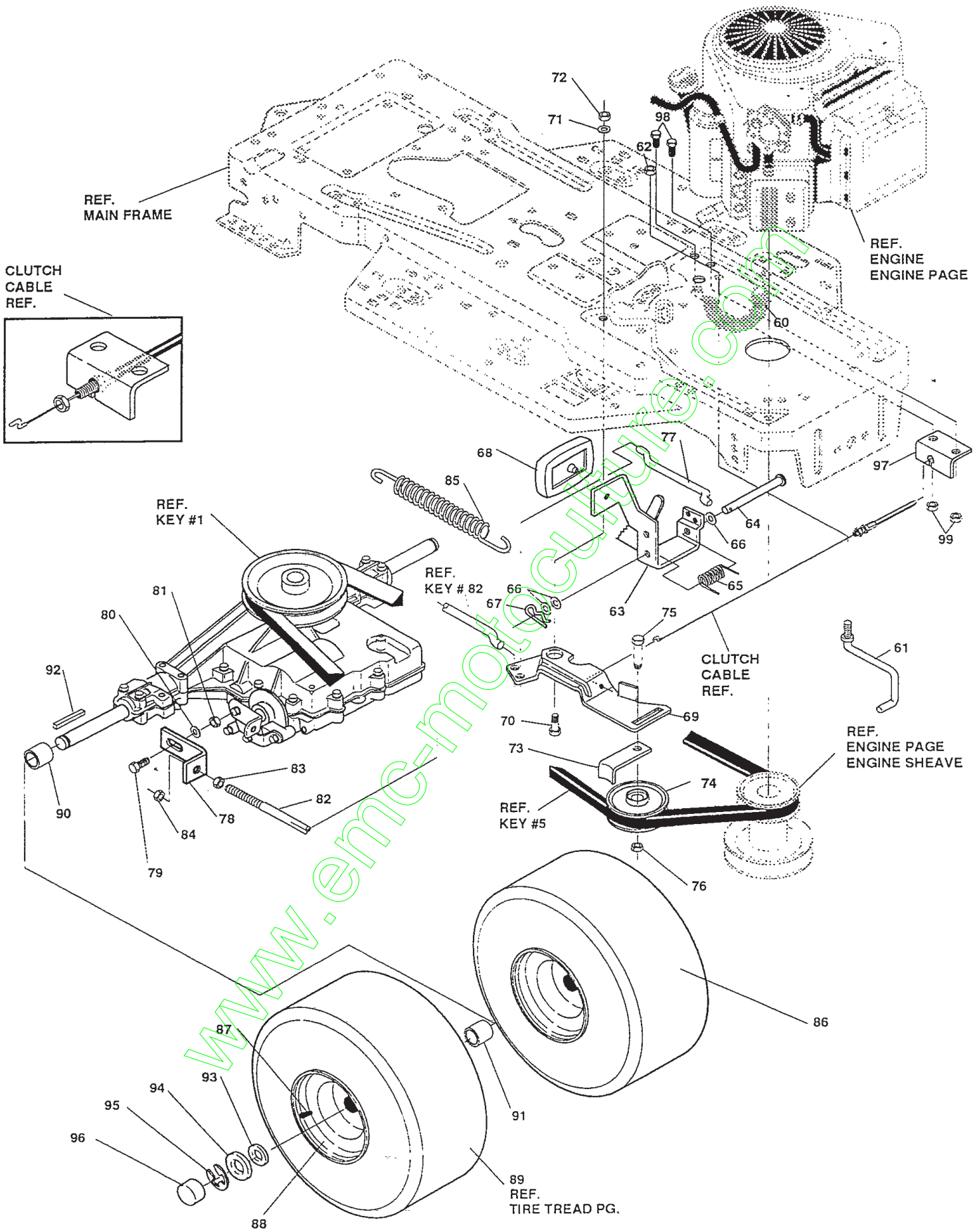

NOTE: ALWAYS USE ORIGINAL EQUIPMENT PARTS.
 Use of service/replacement parts other than original equipment parts may void your warranty.

**ALL UNNUMBERED
 ITEMS ARE INTERCHANGABLE
 WITH OPPOSITE SIDE**

39" LAWN TRACTOR MODEL C3560-420

key#	part#	description	qty
60.	321514	← SPRING BIAS DRAGLINK	1
61.	304016	← GUIDE BELT	1
62.	1498	NUT, 5/16-18 REGHEXCTRLK	1
63.	300308	PEDAL ASSY,BRAKE/CLUTCH LF	1
64.	319675	← PIN CLEVIS	1
65.	57847	SPRING, BRAKE PEDAL	1
66.	2968	WASHER, FLAT .504X .75X.059	3
67.	56180	PIN,HAIR	1
68.	48160	PAD, CLUTCH BRAKE	1
69.	320381	← ARM,IDLER TRACTION,SOG	1
70.	300793	BOLT, .625X .135 HSSH 5/16-18	1
71.	45602	WASHER, FLAT .333X .87X.119	1
72.	• 1498	NUT, 5/16-18 REGHEXCTRLK	1
73.	39659	RETAINER,BELT	1
74.	35374	PULLEY, IDLER V4L 3.06X .62	1
75.	45892	BOLT, 3/8-16X1.50 CARR	1
76.	• 1499	NUT, 3/8-16 REGHXCTRLK	1
77.	57204	ROD, CLUTCH	1
78.	57217	BRACKET, BRAKE ROD	1
79.	20507	BOLT, .437X .156 HSSH 5/16-18	1
80.	45602	WASHER, FLAT .333X .87X.119	1
81.	• 1498	NUT, 5/16-18 REGHEXCTRLK	1
82.	313659	← ROD, BRAKE P920 4WS LF 23.50	1
83.	• 271184	NUT, 5/16-18 HEXKEPS	1
84.	• 1498	NUT, 5/16-18 REGHEXCTRLK	1
85.	322609	← SPRING, CLUTCH	1
86.	-	TIRE & RIM, PU 20X8.0X8 TUR134	2
87.	24167	VALVE STEM	1
88.	57165	WHEEL 20X8.00 WHITE .75 DIAHUB	1
89.	57164	TIRE, PU 20X8.0X8 TURF TREAD C	1
90.	57479	SPACER, SLEV .75 X1.25X1.32	2
91.	301565	← SPACER, SLEV .750X1.25X .50 PL 301656	2
92.	52928	← KEY, SQUARE .1875QX2.25LG	2
93.	642	WASHER, FLAT .755X1.31X.075	4
94.	42815	WASHER, FLAT .755X1.53X.07	2
95.	36625	RING, RETEX .57X.05TRU5133-75	2
96.	40394	HUB CAP, 1.500ID X 7/8LG	2
97.	→ 319591-853	BRKT, FRAME, SHIFT N GO,ZINC PLT	1
98.	• 180018	SCREW, 1/4-20X .62 HHC	2
99.	• 1502	NUT, 1/4-20 REGHEXCTRLK	2

* ORDER INDIVIDUAL PARTS.

• Indicates STANDARD HARDWARE ITEMS.

ENGINE & CONTROL ASSEMBLY

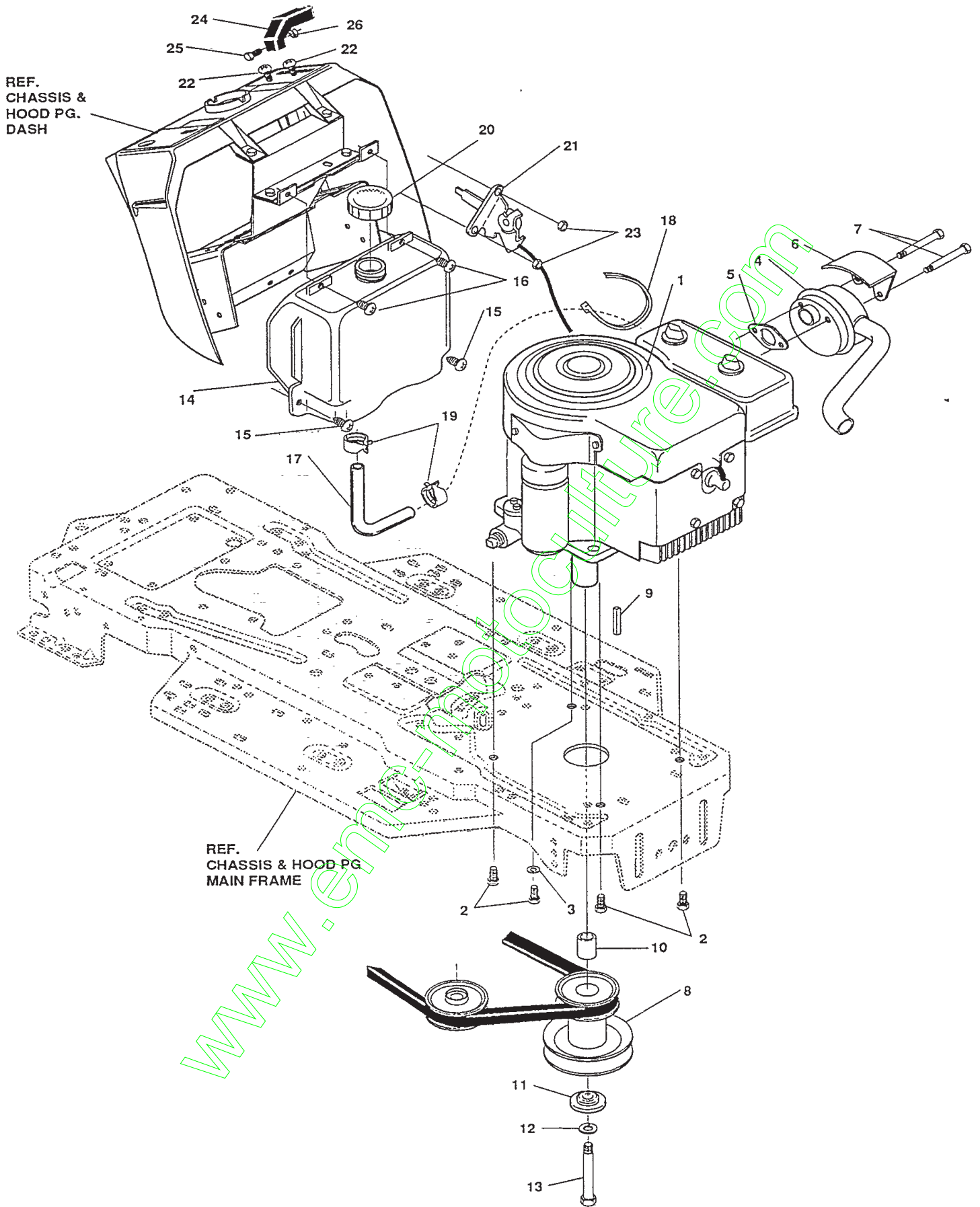

NOTE: ALWAYS USE ORIGINAL EQUIPMENT PARTS.
Use of service/replacement parts other than original equipment parts may void your warranty.

**ALL UNNUMBERED
ITEMS ARE INTERCHANGABLE
WITH OPPOSITE SIDE**

39" LAWN TRACTOR MODEL C3560-420

key#	part#	description	qty.
1	ENGINE	12 HP B&S I/C ECONO (SEE ENGINE MANUAL)	1
2	◇50947	SCREW, 3/8-16X1.25 WAHHTAP	4
3	138489	WASHER, EXLK .384X.69X.04	1
4	305367	MUFFLER-LO TONE NELSON EXPORT	1
5	46708	GASKET, MUFFLER	1
6	54767	SHIELD, HEAT, FOR ROUND MUFFLER	1
7	◇173063	SCREW, 5/16-18X3.50 HHC	2
8	58361	PULLEY ASSY, 4.75OFFS 5.5DIA	1
9	57791	KEY, SQUARE .250SQX5.00LG	1
10	304246	SPACER, 1.01X1.484 ENGIN PULLEY	1
11	56431	WASHER, .980IDX1.38ODX.437PILOT	1
12	120383	WASHER, REGSPTLK.459X.78X.12	1
13	◇428644	SCREW, 7/16-20X5.00 HHC	1
14	314991	TANK, FUEL 2-GAL	1
15	◇300303	SCREW, .25X.75X.75HHWAPLASTITE	2
16	◇995346	SCREW, 1/4-20X .50 WAHHTAP	2
17	47452	GAS LINE .25ID	14"
18	57444	WIRE TIE	1
19	48672	CLAMP, FUEL LINE	2
20	300304	CAP, FUEL - 2.0 THROAT	1
21	303159	THROTTLE, CONTROL	1
22	◇320553	SCREW, 10-24X .63PHPNMA	2
23	◇271166	NUT, #10-24 HEXKEPS	2
24	300508	KNOB, THROTTLE CONTROL HANDGRIP	1
25	◇159585	SCREW, #8-32X .38 PHPNMA	1
26	◇120622	NUT, #8-32 REGHX	1

◇ Indicates STANDARD HARDWARE ITEMS.

www.emc-motoculture.com

39" LAWN TRACTOR MODEL C3560-420

PRE-PAINTED DECK

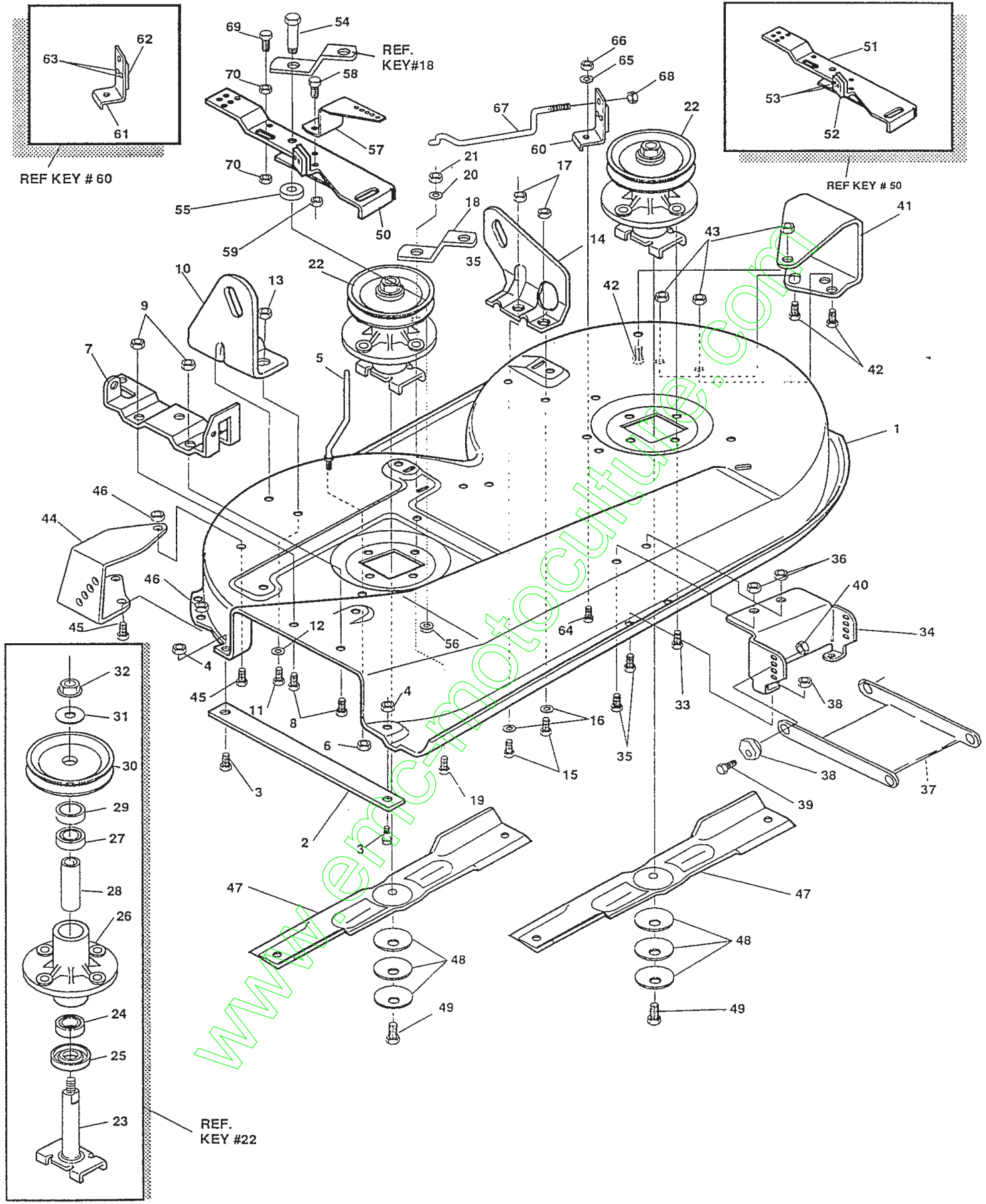

NOTE: ALWAYS USE ORIGINAL EQUIPMENT PARTS. Use of service/replacement parts other than original equipment parts may void your warranty.

ALL UNNUMBERED ITEMS ARE INTERCHANGABLE WITH OPPOSITE SIDE

39" LAWN TRACTOR MODEL C3560-420

key#	part#	description	qty.
1	316186-853	DECK,39"SD MOWER	1
2	57314	BAR, SKID	1
3	126216	BOLT, 5/16-18X .75 CARR	2
4	◊1498	NUT, 5/16-18 REGHEXCTRLK	2
5	57318	GUIDE, BELT 5/16-18 THD	1
6	◊1498	NUT, 5/16-18 REGHEXCTRLK	1
7	57360	BRACKET, CHUTE	1
8	◊120834	SCREW, 5/16-18X .50 HHC	2
9	◊1498	NUT, 5/16-18 REGHEXCTRLK	2
10	58250	LIFT BRACKET, REAR,RH	1
11	◊180077	SCREW, 5/16-18X .75 HHC	2
12	120393	WASHER, FLAT .344X .69X.065	2
13	◊1498	NUT, 5/16-18 REGHEXCTRLK	2
14	58251	BRACKET,DECK LIFTREAR LH	1
15	◊180077	SCREW, 5/16-18X .75 HHC	2
16	120393	WASHER, FLAT .344X .69X.065	2
17	◊1498	NUT, 5/16-18 REGHEXCTRLK	2
18	315302	BRACKET, IDLER SUPPORT	1
19	◊300345	SCREW, 5/16-18X1.38 WATAP	1
20	120393	WASHER, FLAT .344X .69X.065	1
21	◊1498	NUT, 5/16-18 REGHEXCTRLK	1
22	56424	QUILL ASSY, 36/39/40/43	2
23	56425	SHAFT/SADDLE 36"	1
24	49562	BRNG, BALL	1
25	50616	DUST SHIELD	1
26	55547	QUILL CASTING	1
27	49562	BRNG, BALL	1
28	50818	SPACER,3.797LGX.669IDX.88OD	1
29	51449	SPACER,.438LGX.932ODX.672ID-PM	1
30	56390	PULLEY,26/36" QUILL	1
31	56365	SPECIAL WASHER	1
32	◊1282	NUT, 7/16-20 WDFLLK	1
33	◊50634	SCREW, 5/16-18X .88 WAHHTAP	7
34	58315	LIFT SUPPORT FRONT,DECK	1
35	◊180075	SCREW, 5/16-18X .63 HHC	4
36	◊1498	NUT, 5/16-18 REGHEXCTRLK	4
37	58305	LINK BRACKET,DECK FR	1
38	58247	ADJUSTING NUT	2
39	◊122017	SCREW, 5/16-18X1.00 HHC	2
40	◊1498	NUT, 5/16-18 REGHEXCTRLK	2
41	300103	WHEEL BRKT, LH	1
42	◊180075	SCREW, 5/16-18X .63 HHC	3
43	◊1498	NUT, 5/16-18 REGHEXCTRLK	3
44	300102	WHEEL BRKT, RH	1
45	◊180075	SCREW, 5/16-18X .63 HHC	3
46	◊1498	NUT, 5/16-18 REGHEXCTRLK	3
47	57299 309069	BLADE, 39" STD-LIFT 19.5	2
48	2483	WASHER,.39IDX1.25DX.07 BELLVIL	6
49	◊39573	SCREW, 3/8-24X1.00 NYLHHC	2
50	320565	IDLER ARM ASSY.	1
51	300490	IDLER ARM	1
52	306973	BRAKE PAD	1
53	135624	RIVET,TRSET .185 DIA X.41	2
54	300180	BOLT,.50 X .188 HHSH3/8-16	1
55	996416	WASHER,FLAT .391 X 1.— X .125	1
56	45171	NUT,5/16-18 X .75 HHC WHIZ-LOCK	1
57	300700	BRACKET EXTENSION IDLER	1
58	180077	SCREW,5/16-18 X .75 HHC	1
59	1498	NUT, 5/16-18 REGHEXCTRLK	1
60	303247	ASSY BLADE BRAKE	1
61	303246	BRAKE ARM	1
62	306973	BRAKE PAD	1
63	135624	RIVET,TRSET .185 DIA X.41	2
64	120228	SCREW,5/16-18X.63 HHC	1
65	120393	WASHER,FLAT .344 X .69 X. 65	1
66	1498	NUT, 5/16-18 REGHEXCTRLK	1
67	300316	ROD,BRAKE	1
68	1502	NUT,1/4-20 REGHEXCTRLK	1
69	121954	SCREW,1/4-20X2.00 HHC	1
70	271172	NUT,1/4-20 REGHEXKEPS	2

◊ Indicates STANDARD HARDWARE ITEMS

FINAL DECK ASSEMBLY

SEE DWG. 316186 FOR PART ASSEMBLY OF PAINTED DECK

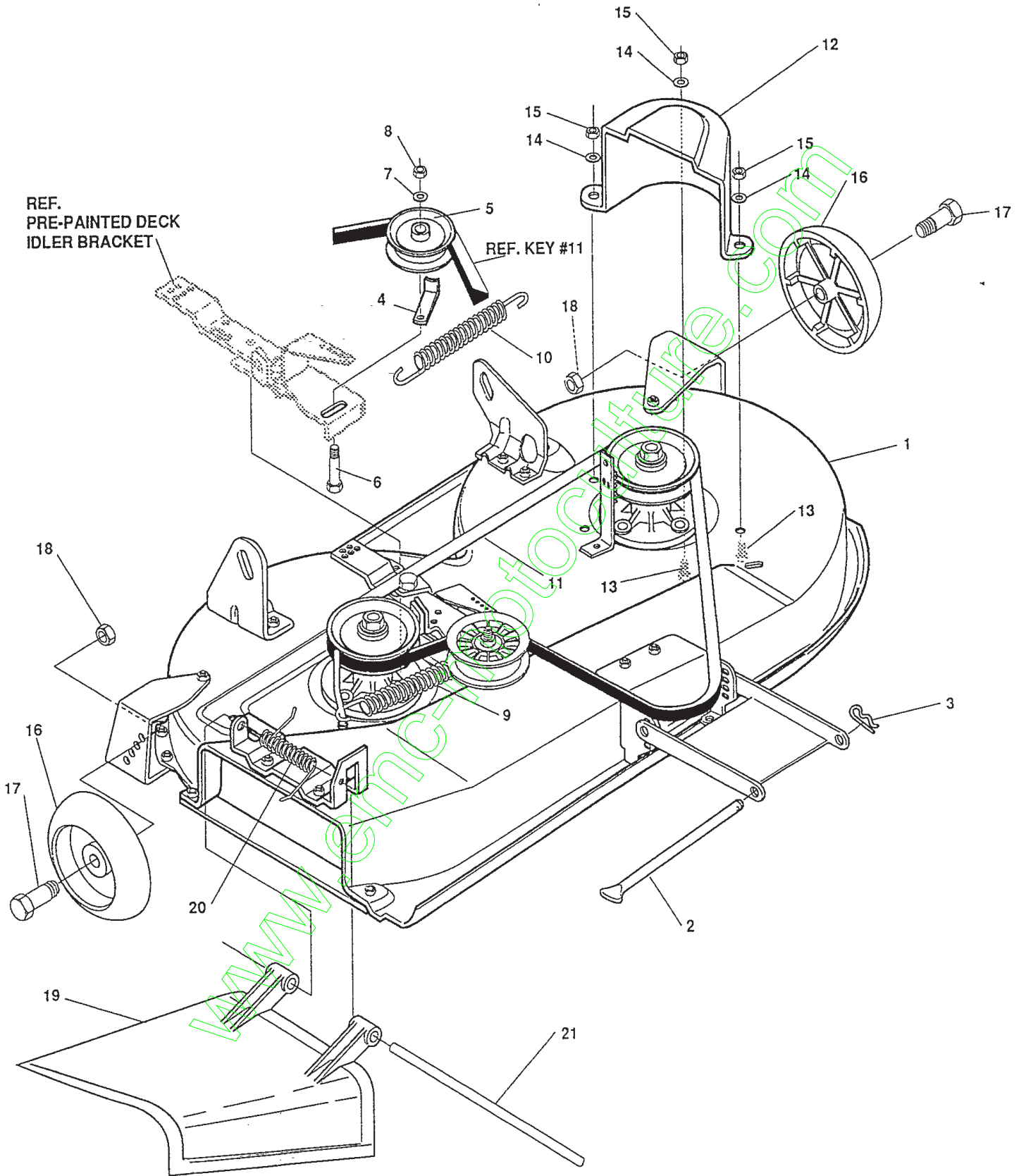

NOTE: ALWAYS USE ORIGINAL EQUIPMENT PARTS. Use of service/replacement parts other than original equipment parts may void your warranty.

ALL UNNUMBERED ITEMS ARE INTERCHANGABLE WITH OPPOSITE SIDE

39" LAWN TRACTOR MODEL C3560-420

key#	part#	description	qty.
1.	*	DECK,ASSY 39"SD SUS	1
2.	58306 -	ROD, DECK HITCH	1
3.	8260	PIN, HAIR .091 DIA X 1.66LG	1
4.	300844-953	RETAINER,BELT	1
5.	303030	PULLEY, IDLER BFF	1
6.	57325	BOLT, 3/8-16 X 2.00 CARR	1
7.	120382	WASHER, REGSPTLK.393X.68X.10	1
8.	• 120377	NUT, 3/8-16 REGHX	1
9.	322064 -	SPRING .071 X .62 X 4.37	1
10.	300473	SPRING,TENSION	1
11.	300680	BELT, V 5L 77.75 KEVLAR	1
12.	302833	GUARD, BELT LH PLASTIC	1
13.	• 120228	SCREW, 5/16-18 X .63 HHC	3
14.	120393	WASHER, FLAT .344X .69X.065	3
15.	• 1498	NUT, 5/16-18 REGHEXCTRLK	3
16.	302611 -	WHEEL, SD 6.00OD X 1.38WD	2
17.	23763	BOLT, .500 X 1.390 HHSH 3/8-16	2
18.	• 1499	NUT, 3/8-16 REGHXCTRLK	2
19.	57818	CHUTE-36SD,39SD,45SD	1
20.	314975	SPRING TORSION CHUTE DEF.	1
21.	57317	PIVOT ROD,CHUTE	1

* ORDER INDIVIDUAL PARTS.
 • Indicates STANDARD HARDWARE ITEMS.

www.emc-motoculture.com

ELECTRICAL ASSEMBLY

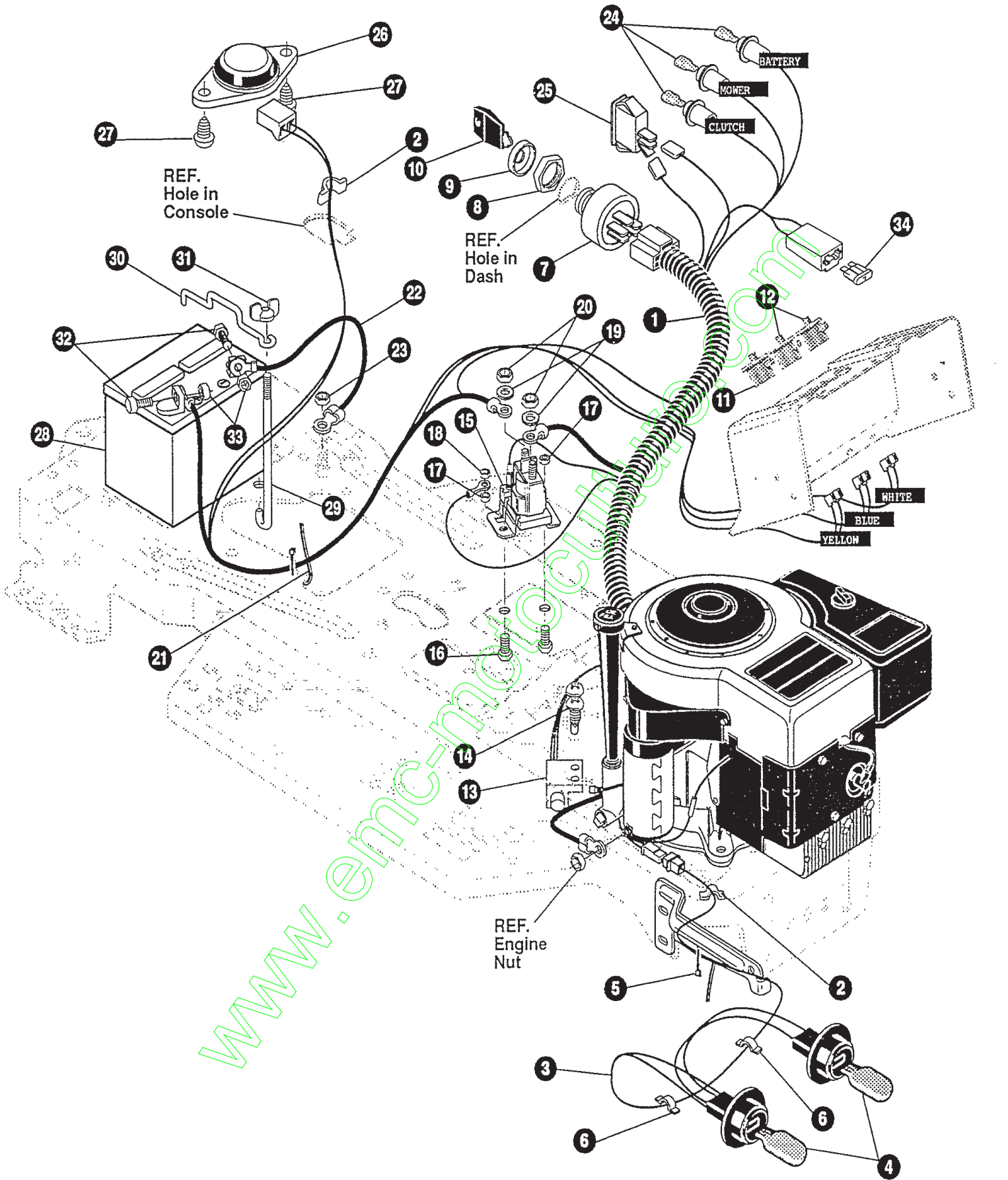

ALL UNNUMBERED ITEMS ARE INTERCHANGABLE WITH OPPOSITE SIDE

NOTE: ALWAYS USE ORIGINAL EQUIPMENT PARTS. Use of service/replacement parts other than original equipment parts may void your warranty.

39" LAWN TRACTOR MODEL C3560-420

key#	part#	description	qty.
1.	320067	HARNES 12-12.5,H11G14,	1
2.	41482	PRESS CLIP,1.380LG .255ID	2
3.	303064	ASSY,LIGHT WIRE-1/4 TURN	1
4.	52572	BULB, HEADLAMP	2
5.	57444	TIE, CABLE BLACK NYLON 5.62L	1
6.	41482	PRESS CLIP,1.380LG .255ID	2
7.	305720	SWITCH-IGN.(AFTER FIRE) 3 POSN	1
8.	300193	NUT, 5/8-32 ACC #125 PLAST BLK	1
9.	300194	BOOT, IGN SWITCH	1
10.	300626	KEY, IGNITION SWITCH	1
11.	300220	SWITCH,SNAPMNT NO .055/.116BLK <i>pTo</i>	1
12.	58277	SWITCH,SNAPMNT NC .055/.166 GR <i>secu</i>	2
13.	57476	SWITCH,SCR MNT DP NC NO BLK <i>Kali</i>	1
14.	57220	SCREW, #12 X .50 PHPNHTAP BLK	2
15.	53716	SOLENOID	1
16.	187745	SCREW, 1/4-20X .75 HXSEMMA	2
17.	1502	NUT, 1/4-20 REGHEXCTRLK	2
18.	271172	NUT, 1/4-20 REGHEXKEPS	1
19.	138485	WASHER, EXLK .320X.61X.03	2
20.	120368	NUT, 5/16-24 REGHEX	2
21.	57444	TIE, CABLE BLACK NYLON 5.62L	1
22.	55511	WIRE, GROUND, 12.5"	1
23.	271184	NUT, 5/16-18 HEXKEPS	1
24.	57769	BULB, INDICATOR	3
25.	300334	LIGHT SWITCH ON/OFF PANEL MNT	1
26.	57547	SWITCH, SEAT <i>57964</i>	1
27.	160505	SCREW, 1/4-20X .38PHPNHMAGR2	2
28. <i>302257</i>	57486	BATTERY 12V 5 PLATE	1
29.	57551	ROD, BATTERY	1
30.	57552	ROD, BATTERY, TOP	1
31.	310067	NUT, WING 1/4-20 SMALL PLASTIC	1
32.	120854	SCREW, 1/4-20X .63 HHC GR2	2
33.	271172	NUT, 1/4-20 REGHEXKEPS	2
34.	302031	FUSE, 15 AMP SPADE TYPE	1

• Indicates STANDARD HARDWARE ITEMS.

SCHEMATIC DRAWING:

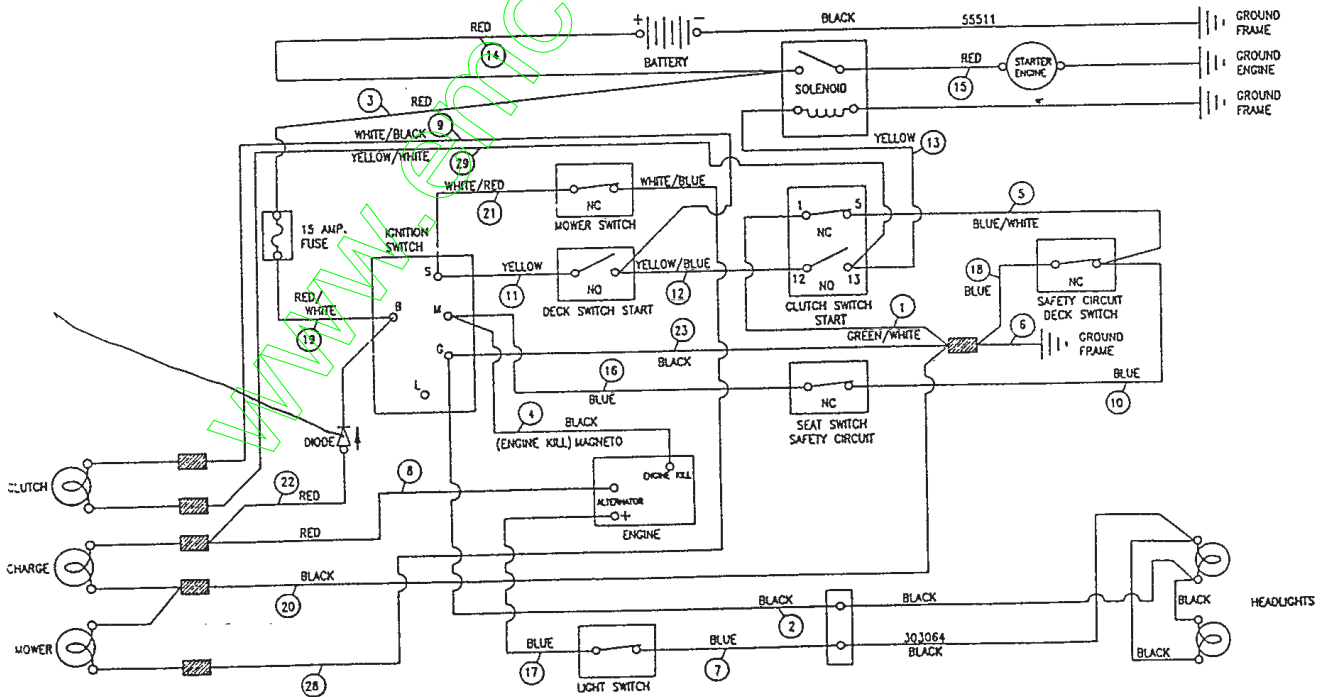

DECALS

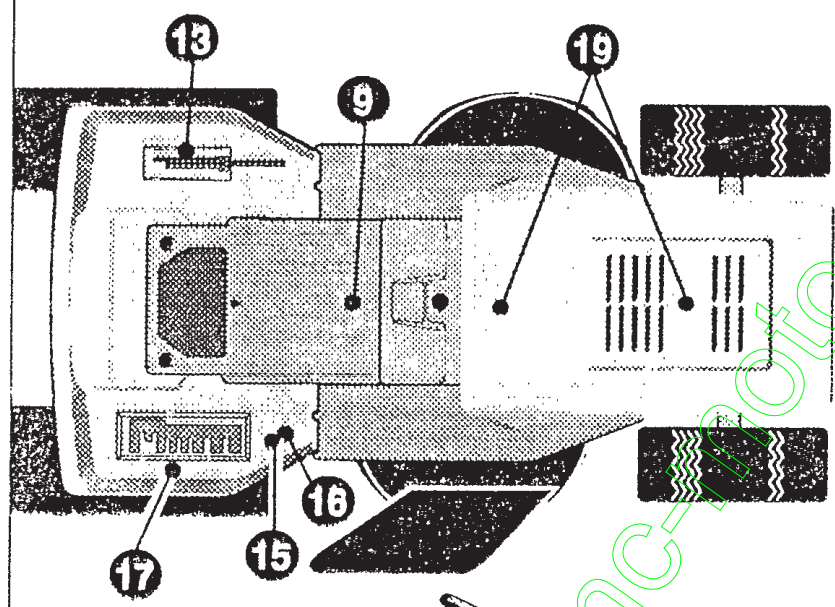
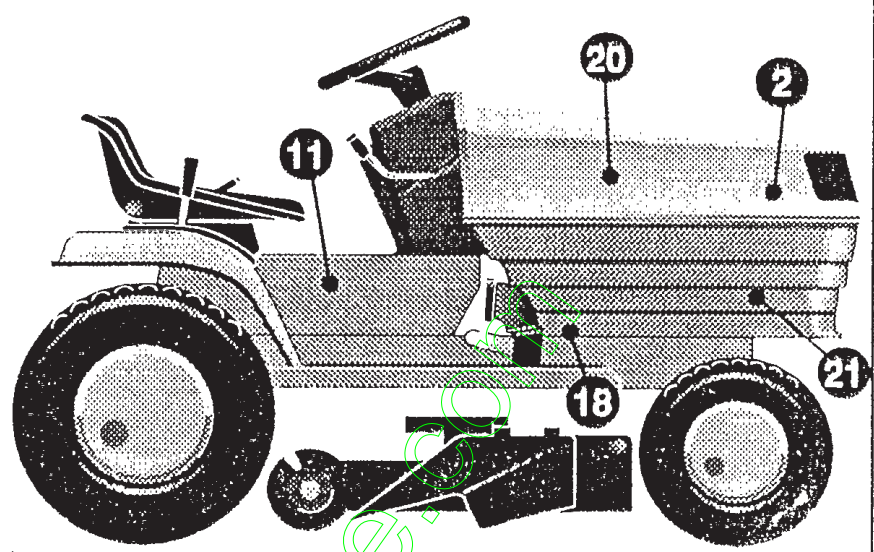
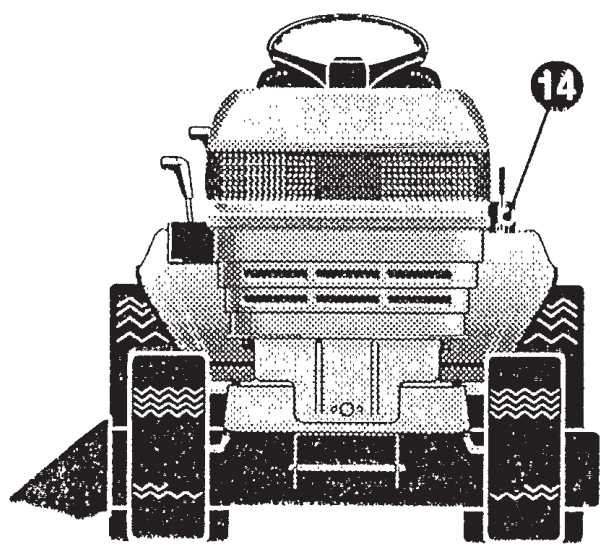

DASH OVERVIEW

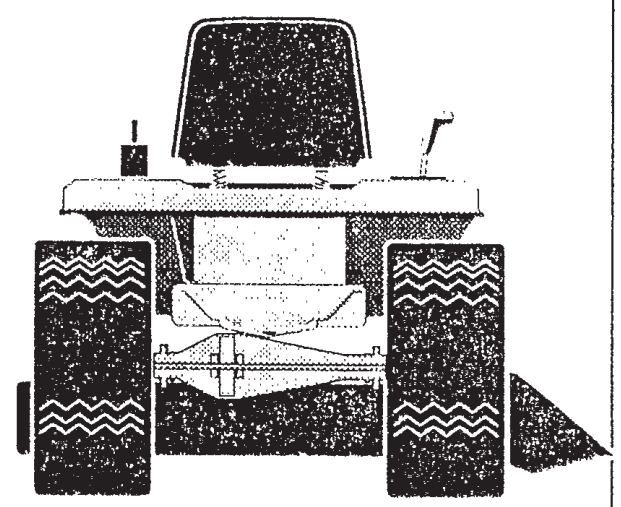
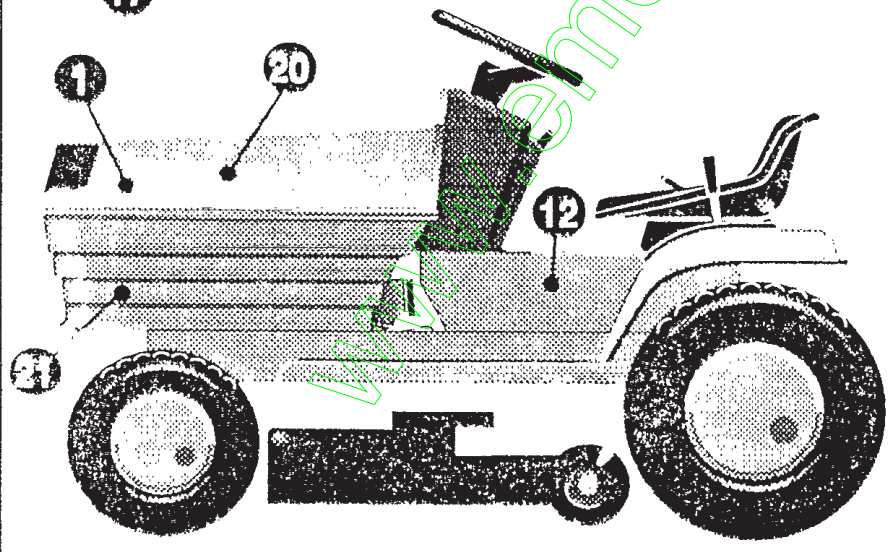
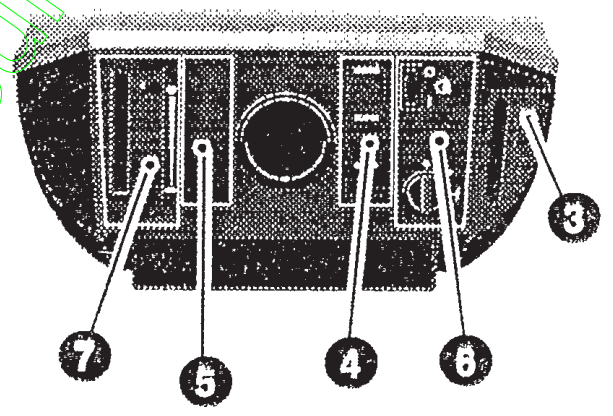

39" LAWN TRACTOR MODEL C3560-420

key#	part#	description	qty.
1.	302003	DECAL HOOD SIDE LH 1239TEX H11	1
2.	302004	DECAL HOOD SIDE RH 1239TEX H11	1
3.	68900	DECAL, BLADE ENGAGE EUROPE	1
4.	300445	DECAL, DASH RH TRANSLUCENT	1
5.	302049	DECAL, DASH LH PLAIN	1
6.	305766	DECAL, DASH, RH IGN	1
7.	305767	DECAL, DASH LH	1
8.		REFERENCE ONLY	1
9.	311972	DECAL, INSTRUCTOR CONS DANISH	1
10.		REFERENCE ONLY	1
11.	323826	DECAL, CONSOLE, 1239QMATIC RH	1
12.	323827	DECAL, CONSOLE, 1239QMATIC LH	1
13.	68901	DECAL, BLADE HEIGHT ADJ. EUROPE	1
14.	301897	DECAL, LIFT DECL BLADE HEIGHT	1
15.	305770	DECAL, CAUTION TRIANGLE EUROPE	1
16.	307830	DECAL, DANGER DAN/SWED/ENGL	1
17.	322169	DECAL, FENDER 6 SPEED SOG	1
18.	68903	DECAL, BRAKE/CLUTCH ISO	2
19.	305602	FOAM, HOOD 4X15	2
20.	305603	PAD, 18 X 6 FOAM HOOD	2
21.	305604	FOAM, HOOD 7 X 12	2

www.emc-motoculture.com

CUSTOMER ASSEMBLY

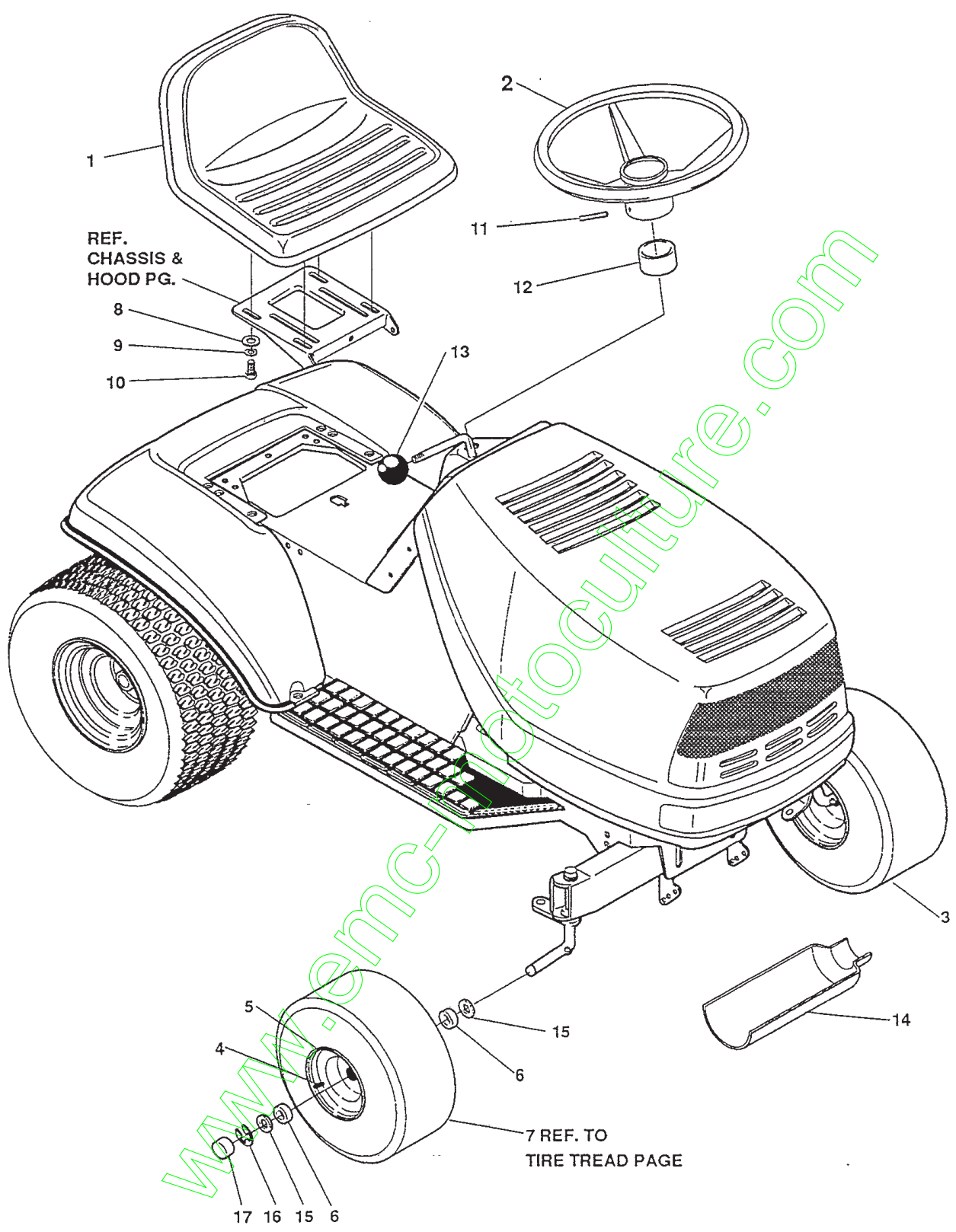

CUSTOMER ASSEMBLY VIEW

317690 PARTS BAG ASSY QTY1

key#	part#	decription	qty
1	57454	SEAT,450 MICH.	1
2	301251	WHEEL, STEERING, 13"	1
3	*	TIRE & RIM, PU 15X6.0X6 TURF	2
4	24167	VALVE STEM	1
5	39829	WHEEL W/BRG.	1
6	39979	BEARING,FL1.38OD+.753ID PM	2
7		REFER TO TIRE TREAD PAGE	
8	120393	WASHER, FLAT .344X .69X.065	4
9	120638	WASHER, HVSPTLK .328X.60X.09	4
10	122007	SCREW, 5/16-18X .75 HHC	4
11	456378	PIN, SPRING.250DIAX2.00LG HVPL	1
12	— 57212	COVER, STEERING SHAFT	1
14	13 54873	TROUGH, OIL DRAIN	1
15	14 642	WASHER, FLAT .755X1.31X.075	4
16	15 36625	RING, RETEX .57X.05TRU5133-75	2
17	16 40394	CAP, 1.500ID X 7/8LG HUB	2

* ORDER INDIVIDUAL PARTS.

www.emc-motoculture.com

TREAD PATTERNS

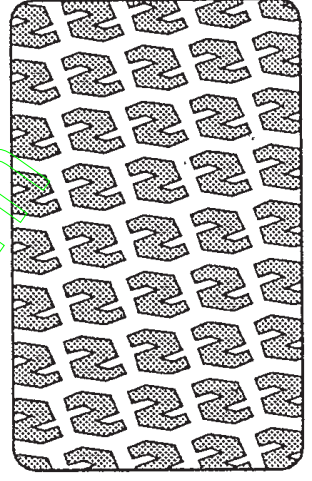
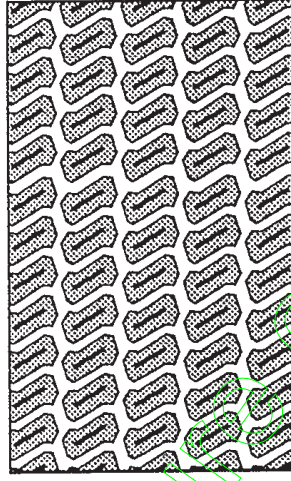
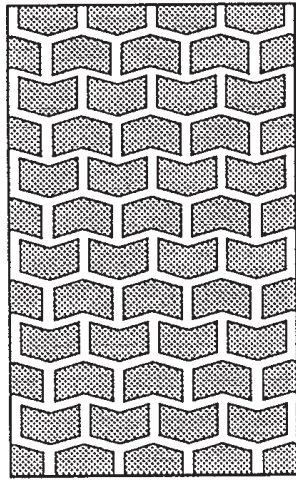
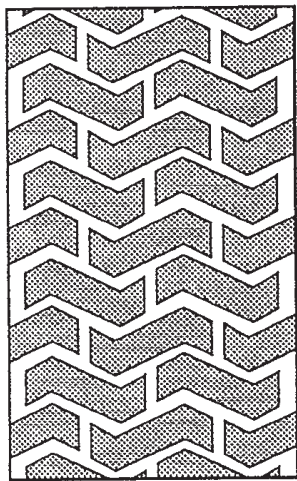

"A"

"B"

"C"

"D"

TIRE SIZE	"A"	"B"	"C"	"D"
11 X 4.00 - 5	42295	319679		
13 X 5.00 - 6	41060	319680		
15 X 6.00 - 6	39830	316702	301140	313952
16 X 6.50 - 8	41081	319682		314539
18 X 8.50 - 8	319683	317400		
18 X 9.50 - 8	41106	316701		313950
20 X 8.00 - 8	319685	319684	57164	314584
20 X 10.00 - 8	58276	319686		313654
20 X 10.00 - 10	55893	319687		
23 X 9.50 - 12	53655	319690	319689	314370

www.ericmotoculture.com